

9

ESSENTIAL MATHEMATICS CORE

FOR THE AUSTRALIAN CURRICULUM

David Greenwood
Sara Woolley
Jenny Goodman
Jennifer Vaughan
Stuart Palmer



CAMBRIDGE
UNIVERSITY PRESS

Shaftesbury Road, Cambridge CB2 8EA, United Kingdom

One Liberty Plaza, 20th Floor, New York, NY 10006, USA

477 Williamstown Road, Port Melbourne, VIC 3207, Australia

314–321, 3rd Floor, Plot 3, Splendor Forum, Jasola District Centre, New Delhi – 110025, India

103 Penang Road, #05–06/07, Visioncrest Commercial, Singapore 238467

Cambridge University Press is part of Cambridge University Press & Assessment,
a department of the University of Cambridge.

We share the University's mission to contribute to society through the pursuit of education,
learning and research at the highest international levels of excellence.

www.cambridge.org

© David Greenwood, Sara Woolley, Jenny Goodman and Jennifer Vaughan 2021

This publication is in copyright. Subject to statutory exception and to the provisions of relevant
collective licensing agreements, no reproduction of any part may take place without the
written permission of Cambridge University Press & Assessment.

First published 2021

20 19 18 17 16 15 14 13 12 11 10 9 8 7 6 5

Cover design by Sardine Design

Typeset by diacriTech

Printed in China by C & C Offset Printing Co., Ltd.

*A catalogue record for this book is available from the National Library of Australia at
www.nla.gov.au*

ISBN 978-1-108-87879-1 Paperback

Additional resources for this publication at www.cambridge.edu.au/GO

Reproduction and Communication for educational purposes

The Australian *Copyright Act 1968* (the Act) allows a maximum of one chapter or 10% of the
pages of this publication, whichever is the greater, to be reproduced and/or communicated by
any educational institution for its educational purposes provided that the educational institution
(or the body that administers it) has given a remuneration notice to Copyright Agency Limited (CAL)
under the Act.

For details of the CAL licence for educational institutions contact:

Copyright Agency Limited

Level 12, 66 Goulburn Street

Sydney NSW 2000

Telephone: (02) 9394 7600

Facsimile: (02) 9394 7601

Email: memberservices@copyright.com.au

Reproduction and Communication for other purposes

Except as permitted under the Act (for example a fair dealing for the purposes of study, research, criticism or review) no part of this
publication may be reproduced, stored in a retrieval system, communicated or transmitted in any form or by any means without prior written
permission. All inquiries should be made to the publisher at the address above.

Cambridge University Press & Assessment has no responsibility for the persistence or accuracy of URLs for external or third-party internet
websites referred to in this publication and does not guarantee that any content on such websites is, or will remain, accurate or appropriate.
Information regarding prices, travel timetables and other factual information given in this work is correct at the time of first printing but
Cambridge University Press & Assessment does not guarantee the accuracy of such information thereafter.

*Cambridge University Press & Assessment acknowledges the Australian Aboriginal and Torres Strait Islander peoples of this nation. We
acknowledge the traditional custodians of the lands on which our company is located and where we conduct our business. We pay our
respects to ancestors and Elders, past and present. Cambridge University Press & Assessment is committed to honouring Australian Aboriginal
and Torres Strait Islander peoples' unique cultural and spiritual relationships to the land, waters and seas and their rich contribution to society.*

Contents

<i>About the authors</i>	<i>viii</i>
<i>Acknowledgements</i>	<i>ix</i>
<i>Introduction and guide to this resource</i>	<i>x</i>

Strand and content description

1	Reviewing number	2	Number and Algebra
	Warm-up quiz	4	Real numbers
1A	Adding and subtracting integers CONSOLIDATING	5	
1B	Multiplying and dividing integers CONSOLIDATING	9	
1C	Rounding decimals and significant figures	14	
1D	Rational and irrational numbers CONSOLIDATING	19	
1E	Adding and subtracting fractions CONSOLIDATING	25	
	Progress quiz	30	
1F	Multiplying and dividing fractions CONSOLIDATING	31	
1G	Ratios CONSOLIDATING	36	
1H	Rates and direct proportion	40	
	Maths@Work: Cooks and chefs	46	
	Modelling	48	
	Puzzles and games	50	
	Chapter summary and checklist	51	
	Chapter review	55	
2	Financial mathematics	58	Number and Algebra
	Warm-up quiz	60	Money and financial mathematics
2A	Percentages CONSOLIDATING	61	
2B	Applying percentages CONSOLIDATING	66	
2C	Percentage increase and decrease CONSOLIDATING	69	
2D	Profits and discounts CONSOLIDATING	74	
2E	Income	79	
	Progress quiz	84	
2F	Taxation	85	
2G	Simple interest	89	
2H	Applications of simple interest	94	
	Maths@Work: Facebook cake-decorating business	99	
	Modelling	101	
	Puzzles and games	103	
	Chapter summary and checklist	104	
	Chapter review	107	

3	Expressions and equations	110	Number and Algebra	
	Warm-up quiz	112	Linear and non-linear relationships	
3A	Algebraic expressions CONSOLIDATING	113		
3B	Adding and subtracting algebraic expressions CONSOLIDATING	119		
3C	Multiplying and dividing algebraic expressions CONSOLIDATING	123		
3D	Expanding algebraic expressions	127		
3E	Solving linear equations CONSOLIDATING	132		
3F	Solving linear equations involving fractions	136		
	Progress quiz	141		
3G	Solving equations with brackets	142		
3H	Solving equations with pronumerals on both sides	145		
3I	Solving word problems ★	150		
3J	Using formulas ★	155		
	Maths@Work: Plumber	160		
	Modelling	162		
	Puzzles and games	164		
	Chapter summary and checklist	165		
	Chapter review	168		
4	Pythagoras' theorem and trigonometry	170		Measurement and Geometry
	Warm-up quiz	172		Pythagoras and trigonometry
4A	Exploring Pythagoras' theorem	173		
4B	Finding the length of the hypotenuse	177		
4C	Finding the lengths of the shorter sides	182		
4D	Applying Pythagoras' theorem ★	186		
4E	Trigonometric ratios	191		
4F	Finding side lengths	198		
	Progress quiz	203		
4G	Solving for the denominator	205		
4H	Finding an angle	210		
4I	Applying trigonometry ★	215		
	Maths@Work: Carpenter	220		
	Modelling	222		
	Puzzles and games	224		
	Chapter summary and checklist	225		
	Chapter review	228		

5	Linear relations	232	Number and Algebra
	Warm-up quiz	234	Linear and non-linear relationships
5A	Introduction to linear relations	235	
5B	Finding x - and y -intercepts	242	
5C	Graphing straight lines using intercepts	248	
5D	Lines with one intercept	252	
5E	Gradient	258	
5F	Gradient and direct proportion	265	
5G	Gradient–intercept form	270	
	Progress quiz	276	
5H	Finding the equation of a line ★	278	
5I	Midpoint and length of a line segment	283	
5J	Linear modelling ★	288	
5K	Non-linear graphs	292	
	Maths@Work: Trading in foreign currencies	298	
	Modelling	300	
	Puzzles and games	302	
	Chapter summary and checklist	303	
	Chapter review	307	
	Semester review 1	311	

6	Measurement	318	Measurement and Geometry
	Warm-up quiz	320	Using units of measurement
6A	Length and perimeter CONSOLIDATING	321	
6B	Circumference of a circle CONSOLIDATING	326	
6C	Area CONSOLIDATING	331	
6D	Area of a circle CONSOLIDATING	337	
6E	Composite shapes	341	
6F	Surface area of prisms	346	
	Progress quiz	351	
6G	Surface area of a cylinder	353	
6H	Volume	358	
6I	Volume of a cylinder	364	
	Maths@Work: Vegetable and fruit growers	368	
	Modelling	370	
	Puzzles and games	372	
	Chapter summary and checklist	373	
	Chapter review	376	

7	Indices	380	Number and Algebra
	Warm-up quiz	382	Real numbers
7A	Index notation CONSOLIDATING	383	Patterns and algebra
7B	Index laws 1 and 2	391	
7C	Index law 3 and the zero power	397	
7D	Index laws 4 and 5	402	
7E	Negative indices ★	408	
	Progress quiz	413	
7F	Scientific notation	414	
7G	Scientific notation using significant figures	419	
	Maths@Work: Lab technician	424	
	Modelling	426	
	Puzzles and games	428	
	Chapter summary and checklist	429	
	Chapter review	432	
8	Geometry	434	Measurement and Geometry
	Warm-up quiz	436	Geometric reasoning
8A	Angles and triangles CONSOLIDATING	437	
8B	Parallel lines CONSOLIDATING	444	
8C	Quadrilaterals CONSOLIDATING	450	
8D	Polygons ★	455	
8E	Congruent triangles	460	
	Progress quiz	466	
8F	Enlargement and similar figures	467	
8G	Similar triangles	473	
8H	Applying similar triangles	479	
	Maths@Work: Animator	483	
	Modelling	485	
	Puzzles and games	487	
	Chapter summary and checklist	488	
	Chapter review	492	
9	Algebraic techniques	496	Number and Algebra
	Warm-up quiz	498	Patterns and algebra
9A	Reviewing algebra CONSOLIDATING	499	
9B	Expanding binomial products	504	
9C	Expanding perfect squares	508	
9D	Forming a difference of perfect squares	512	
9E	Factorising algebraic expressions	515	
	Progress quiz	519	
9F	Simplifying algebraic fractions: multiplication and division ★	520	
9G	Simplifying algebraic fractions: addition and subtraction ★	525	
	Maths@Work: Automotive technology	529	
	Modelling	531	
	Puzzles and games	533	
	Chapter summary and checklist	534	
	Chapter review	536	

10	Statistics and probability	538	Statistics and Probability
	Warm-up quiz	540	Chance
10A	Review of probability CONSOLIDATING	541	Data representation and interpretation
10B	Venn diagrams and two-way tables	548	
10C	Using arrays for two-step experiments	557	
10D	Tree diagrams	564	
10E	Experimental probability	569	
10F	Summarising data: range and measures of centre	574	
	Progress quiz	579	
10G	Interpreting data from tables and graphs	581	
10H	Stem-and-leaf plots	590	
10I	Grouped data	597	
	Maths@Work: Personal trainer	604	
	Modelling	606	
	Puzzles and games	608	
	Chapter summary and checklist	609	
	Chapter review	612	
	Semester review 2	616	
	<i>Glossary</i>	<i>624</i>	
	<i>Answers</i>	<i>630</i>	

About the Authors

David Greenwood is the Head of Mathematics at Trinity Grammar School in Melbourne and has 25+ years' experience teaching mathematics from Years 7 to 12. He has run numerous workshops within Australia and overseas regarding the implementation of the Australian Curriculum and the use of technology for the teaching of mathematics. He has written more than 30 mathematics titles and has a particular interest in the sequencing of curriculum content and working with the Australian Curriculum proficiency strands.



Sara Woolley was born and educated in Tasmania. She completed an Honours degree in Mathematics at the University of Tasmania before completing her education training at the University of Melbourne. She has taught mathematics in Victoria from Years 7 to 12 since 2006 and is currently a Head of Mathematics. She has written more than 15 mathematics titles and specialises in lesson design and differentiation.



Jennifer Vaughan has taught secondary mathematics for more than 30 years in New South Wales, Western Australia, Queensland and New Zealand, and has tutored and lectured in mathematics at Queensland University of Technology. She is passionate about providing students of all ability levels with opportunities to understand and to have success in using mathematics. She has had extensive experience in developing resources that make mathematical concepts more accessible; hence, facilitating student confidence, achievement and an enjoyment of maths.



Jenny Goodman has taught in schools for more than 25 years and is currently teaching at a selective high school in Sydney. Jenny has an interest in the importance of literacy in mathematics education, and in teaching students of differing ability levels. She was awarded the Jones Medal for Education at Sydney University and the Bourke Prize for Mathematics. She has written for *CambridgeMATHS NSW* and was involved in the *Spectrum and Spectrum Gold* series.



Stuart Palmer has been a head of department in two schools and is now an educational consultant who conducts professional development workshops for teachers all over New South Wales and beyond. He is a Project Officer with the Mathematical Association of New South Wales, and also works with pre-service teachers at The University of Sydney and Western Sydney University.



Acknowledgements

The author and publisher wish to thank the following sources for permission to reproduce material:

Cover: © Getty Images

Images: © Getty Images / Tom Werner, Chapter Opener 1 / Andrew Aitchison, Chapter Opener 2 / Sami Sarkis, Chapter Opener 3 / Dan Reynolds Photography, Chapter Opener 4 / The Creative Drone, Chapter Opener 5 / John Lamb, Chapter Opener 6 / AFP Contributor, Chapter Opener 7 / Roman Becker, Chapter Opener 8 / Stanislaw Pytel, Chapter Opener 9 / john finney photography, Chapter Opener 10 / 10'000 Hours, Ch1 end (1) / andresr, Ch1 end (2) / Hispanolistic, Ch2 (end) / apomares, Ch3 (end) / Matt Carr, Ch4 (end) / Alistair Berg, Ch5 (end) / gilaxia, Ch6 (end) / Jose A. Bernat Bacete, Ch 7 (end) / Samere Fahim Photography, Ch 8 (end) / Lingbeek, Ch 9 (end) / Tommi Kokkola Photography, Ch 10 (end 1) / Image Source, Ch 10 (end 2) / prapassong, 1H (2) / GlobalP, 1H (3) / George Mdivanian, 1H (4) / DaveThomasNZ, 1H (5) / Life On Whit, 1H (6) / zokru, 1H (7) / artpipi, 1H (8) / Salvador_Badiella, 1H (9) / Anankmkl, 1H (10) / JackF, 1H (12) / GlobalP, 1H (13) / Yuichiro Chino, 1A (1) / Adam Gault, 1B (1) / SusanWoodImages, 1B (2) / Juan Silva, 1C (1) / Clerkenwell, 1C (2) / Monty Rakusen, 1C (3) / Busà Photography, 1D (1) / Comstock, 1E (1) / John W Banagan, 1E (2) / by Elena Veselova, 1E (3) / Annabelle Breakey, 1E (4) / Gaelle Beller Studio, 1F (1) / EujarimPhotography, 1F (2) / Nicola Tree, 1F (3) / seksan Mongkhonkamsao, 1F (4) / ArtMarie, (1) / Betsie Van der Meer, 1G (2) / Halfdark, 1G (3) / Martyn Goddard, 1H (1) / Viktor Peschel, 1H (11) / Michael Hall, 1H (16) / Image Source, 1H (17) / Milo Zanecchia, 1H (18) / Ryan Cutler, 1H (21) / Peepo Chapter 1 Review (1) / Jacobs Stock Photography Ltd, Chapter 1 Review (2) / aluxum, 1H (15) / Nina Van Der Klei, 1H (20) / Ryan Pierse, 1H (14) / Andrew Aitchison, Chapter 2 Opener / yasinguneyu, 2C (2) / Studiocaspar 2D (3) / JazzIRT, 2D (4) / Firdausiah Mamat, 2G (1) / kali9, Chapter 2 Review (2) / Kentaroo Tryman, 2A (1) / Waldemar Blazej Nowak, 2A (2) / Jose Luis Pelaez Inc, 2A (3) / Skynesher, 2B (1) / Peter Dazeley, 2C (1) / Bruce Yuanyue Bi, 2D (5) / Morsa Images, 2E (1) / urbazon, 2F (1) / Tom Werner, 2F (2) / Betsie Van der Meer, 2G (2) / Westend61, 2H (1) / JGI/Jamie Grill, 2H (2) / Witthaya Prasongsin, 2H (3) / Aleksandr Zubkov, 2H (5) / courtneyk, Chapter 2 Review (1) / clubfoot, 2D (2) / Chris Ryan, 2F (3) / Stijn Dijkstra, Chapter 3 Opener / Neilymagery, 3B (2) / rolfo eclaire, 3F (2) / JohnnyGreig, 3G (1) / Ivanastar, 3I (3) / Maskot, 3A (1) / Yulia Naumenko, 3A (2) / Westend61, 3D (1) / Emanuel M Schwermer, 3E (1) / Maskot, 3H (1) / Tom Werner, 3H (2) / Frank van Delft, 3I (1) / Boy_Anupong, 3J (1) / Image Source, 3J (2) / Dorling Kindersley, 3J (3) / Cavan Images, 3I (2) / Lindy Kyle, Lindy Kyle // ZU_09, 4A (1) / courtneyk, 4B (2) / Robin Smith, 4D (1) / mabus13, 4G (2) / Kittikorn Nimitpara, 4H (1) / desifoto, 4B (1) / Fotosearch, 4C (1) / aluxum, 4E (1) / Cesare Fel, 4E (3) / Frisco, 4E (4) / Georgijevic, Georgijevic, 4F (1) / Westend61, 4F (3) / Tommy Colombet, 4G (1) / Image Source, 4H (2) / gilaxia, 4H (3) / Atlantide Phototravel, 4H (4) / Bill Green, 4I (1) / Luca Sgualdini, 4I (3) / Simon McGill, 4I (4) / Daniel H. Bailey, 4I (5) / Guido Mieth, 4I (6) / Bim, 4I (2) / Vostok, Chapter 4 Review (1) / Mads Wollesen, Chapter 4 Review (2) / Virojt Changyenham, 5A (1) / Giovanna Graf, Giovanna Graf / Darya Bystritskaya, 5B (2) / Andriy Onufriyenko, 5C (1) / Trevor Watchous, 5C (2) / Image Source, 5D (1) / Buena Vista Images, 5E (1) / Jose A. Bernat Bacete, 5E (2) / Suneet Bhardwaj/500px, 5F (2) / Annie Otzen, 5G (2) / Travis Wolfe, 5G (3) / Martin Barraud, 5I (1) / John Coletti, 5I (3) / prognone, 5K (1) / Witthaya Prasongsin, 5K (2) / Photographer is my life, 5K (3) / Alistair Berg, 5K (4) / Kyle Willis, Chapter 5 Review (1) / darrya, darrya / by Andrea Pucci 5I (2) / YvanDube, 5J (1) / carlosalvarez, Chapter 5 Review (2) / Douglas Sacha, 5F (1) / John M Lund Photography Inc, 5G (1) / Hello Africa, SR1 (1) / Cavan Images, SR1 (2) / Westend61, SR1 (3) / Juanmonino, Y Stocktrek Images, 6A (1) / Hisham Ibrahim, Hisham Ibrahim / JamesBrey, 6A (3) / xavierarnau, 6B (1) / Aleli Dezmen, 6B (2) / Cavan Images, 6B (3) / Achim Thomae, 6C (1) / Matt Champlin, 6C (2) / EschCollection, 6D (2) / Michael Dunning, 6F (1) / JustinBlackStock, 6F (3) / Colinda Jansen, 6G (2) / tucko019, 6G (3) / Colorblind Images LLC, 6I (1) / Douglas Sacha, 6I (2) / Mint Images - Tim Robbins, 6I (3) / Zelma Brezinska, 6I (6) / mikroman6, Chapter 6 Review (1) / Reinhard Krull, Chapter 6 Review (2) / Mr.samarn Plubkilang, Chapter 6 Review (3) / Peter Zelei Images, 6C (3) / Thanpisit Thongdam, 6D (1) / Jeffrey Coolidge, 7A (1) / Rodolfo Parulan Jr, 7A (2) / Barbara Rich 7D (1), 7F (1) / LEONELLO CALVETTI, 7F (2) / MARK GARLICK, 7F (4) / Matthias Kulka, 7G (1) / vandervelden, 7C (1) / Tomatoskin, 8E (1) / Luis Alvarez, 8F (1) / Artie Photography (Artie Ng), 8H (2) / Matelly, 9A (1), 9B (1) / Zero Creatives, 10A (1) / Cristobal Marambio, 10E (1) / Hagen Hopkins, 10C (1) / Per Winbladh, 10I (2) / Avatarmin, SR2 (1) / Henrik5000, SR2 (2) / P_Wei, SR2 (3) / ER Productions Limited, 11 (3).

© Australian Curriculum, Assessment and Reporting Authority (ACARA) 2009 to present, unless otherwise indicated. This material was downloaded from the ACARA website (www.acara.edu.au) (accessed 2019/2020 and was not modified). The material is licensed under CC BY 4.0 (<https://creativecommons.org/licenses/by/4.0/>). ACARA does not endorse any product that uses ACARA material or make any representations as to the quality of such products. Any product that uses material published on this website should not be taken to be affiliated with ACARA or have the sponsorship or approval of ACARA. It is up to each person to make their own assessment of the product.

Every effort has been made to trace and acknowledge copyright. The publisher apologises for any accidental infringement and welcomes information that would redress this situation.

Introduction

Essential Mathematics CORE for the Australian Curriculum is the successor to the prior *GOLD* series. The new name better reflects the nature of the series: a set of books that focuses on covering the basics of the curriculum in an accessible, straightforward manner. It has been tailored to the Australian Curriculum and is best suited for students aiming to undertake General Mathematics, Essential Mathematics or a VET pathway in Years 11 and 12.

Compared to previous editions, the *CORE* series features some substantial new features in the print and digital versions of the textbook, as well as in the Online Teaching Suite. The main ones are listed below.

Learning intentions and chapter checklist

At the beginning of every lesson is a set of learning intentions that describe what the student can expect to learn in the lesson. At the end of the chapter, these appear again in the form of a chapter checklist of “I can...” statements; students can use this to check their progress through the chapter. Every criterion is listed with an example question to remind students of what the mathematics looks like. These checklists can also be downloaded and printed off so that students can physically check them off as they accomplish their goals.

Now you try

Every worked example now contains additional questions, without solutions, called ‘Now you try’. We anticipate many uses of these questions, first and foremost to give students immediate practice at what they’ve just seen demonstrated in a worked example, rather than expecting students to simply absorb the example by reading through it. We also anticipate these questions will be useful for the teacher to do in front of the class, given that students will not have seen the solution or answer before.

Modelling activities

A modelling activity has been added to every chapter, with the goal of familiarising students with using the modelling process to define, solve, verify and then communicate their solutions to realistic problems. The activities are scaffolded, and each activity begins with a preliminary task and ends with an optional extension task.

Workspaces and self-assessment

In the Interactive Textbook, students can complete almost any question from the textbook inside the platform via workspaces. Questions can be answered with full worked solutions using three input tools: ‘handwriting’ using a stylus, inputting text via a keyboard and in-built symbol palette, or uploading an image of work completed elsewhere. Then students can critically engage with their own work using the self-assessment tools, which allow them to rate their confidence with their work and also red-flag to the teacher any questions they have not understood. All work is saved, and teachers will be able to see both students’ working-out and how they’ve assessed their own work via the Online Teaching Suite.

Note that the workspaces and self-assessment feature is intended to be used as much or as little as the teacher wishes, including not at all (the feature can be turned off). However, the ease with which useful data can be collected will make this feature a powerful teaching and learning tool when used creatively and strategically.

Guide to the working programs

Essential Mathematics CORE for the Australian Curriculum contains working programs that are subtly embedded in the exercises. The suggested working programs provide two pathways through the book to allow differentiation for Building and Progressing students.

Each exercise is structured in subsections that match the Australian Curriculum proficiency strands (with Problem-solving and Reasoning combined into one section to reduce exercise length), as well as 'Gold star' (★). The questions* suggested for each pathway are listed in two columns at the top of each subsection.

- The left column (lightest shade) shows the questions in the Building working program.
- The right column (darkest shade) shows the questions in the Progressing working program.

Gradients within exercises and proficiency strands

The working programs make use of two gradients that have been carefully integrated into the exercises. A gradient runs through the overall structure of each exercise – where there's an increasing level of sophistication required as a student progresses through the proficiency strands and then on to the 'Gold Star' question(s) – but also within each proficiency strand; the first few questions in Fluency are easier than the last few, for example, and the first few Problem-solving and reasoning questions are easier than the last few.

	Building	Progressing
Understanding	1–3	3
Fluency	4–6	4–6(½)
Problem-solving and reasoning	7–9	8–11
★	–	12

The right mix of questions

Questions in the working programs have been selected to give the most appropriate mix of types of questions for each learning pathway. Students going through the Building pathway are given extra practice at the Understanding and basic Fluency questions and only the easiest Problem-solving and reasoning questions. The Progressing pathway, while not challenging, spends a little less time on basic Understanding questions and a little more on Fluency and Problem-solving and reasoning questions.) The Progressing pathway also includes the 'Gold star' question(s).

Choosing a pathway

There are a variety of ways of determining the appropriate pathway for students through the course. Schools and individual teachers should follow the method that works best for them. If required, the Warm-up quiz at the start of each chapter can be used as a diagnostic to. The following are recommended guidelines:

- A student who gets 40% or lower should heavily revise core concepts before doing the Building questions, and may require further assistance.
- A student who gets between 40% and 75% should do the Building questions.
- A student who gets 75% and higher should do the Progressing questions.

For schools that have classes grouped according to ability, teachers may wish to set either the Building or Progressing pathways as the default pathway for an entire class and then make individual alterations depending on student need. For schools that have mixed-ability classes, teachers may wish to set a number of pathways within the one class, depending on previous performance and other factors.

* The nomenclature used to list questions is as follows:

- 3, 4: complete all parts of questions 3 and 4
- 10(½): complete half of the parts from question 10 (a, c, e, or b, d, f,)
- 4(½), 5: complete half of the parts of question 4 and all parts of question 5
- 1–4: complete all parts of questions 1, 2, 3 and 4
- 2–4(½): complete half of the parts of questions 2, 3 and 4
- – : complete none of the questions in this section.

Guide to this resource

PRINT TEXTBOOK FEATURES

- 1 Australian Curriculum:** content strands, sub-strands and content descriptions are listed at the beginning of the chapter (see the teaching program for more detailed curriculum documents)
- 2 In this chapter:** an overview of the chapter contents
- 3 Chapter introduction:** sets context for students about how the topic connects with the real world and the history of mathematics
- 4 Warm-up quiz:** a quiz for students on the prior knowledge and essential skills required before beginning each chapter
- 5 Sections labelled to aid planning:** All non-core sections are labelled as 'Consolidating' (indicating a revision section) or with a gold star (indicating a topic that could be considered challenging) to help teachers decide on the most suitable way of approaching the course for their class or for individual students.
- 6 NEW Learning intentions:** sets out what a student will be expected to learn in the lesson
- 7 Lesson starter:** an activity, which can often be done in groups, to start the lesson
- 8 Key ideas:** summarises the knowledge and skills for the section
- 9 Worked examples:** solutions and explanations of each line of working, along with a description that clearly describes the mathematics covered by the example. Worked examples are placed within the exercise so they can be referenced quickly, with each example followed by the questions that directly relate to it.
- 10 NEW Now you try:** try-it-yourself questions provided after every worked example in exactly the same style as the worked example to give students immediate practice

2A Review of percentages CONSOLIDATING 67

Learning intentions

- To understand that a percentage is a number out of 100
- To be able to convert decimals and fractions to percentage and vice versa
- To be able to find the percentage of a quantity

Key vocabulary: percentage, denominator

It is important that we are able to work with percentages in our everyday lives. Banks, retailers and governments use percentages every day to work out fees and prices.

Lesson starter: Which option should Jamie choose?

Jamie currently earns \$68 460 p.a. (per year) and is given a choice of two different pay rises. Which should she choose and why?

Choice A: Increase of \$25 per week
Choice B: Increase of 2% on per-annum salary

Key ideas

- A percentage means 'out of 100'. It can be written using the symbol %, or as a fraction or a decimal.
For example: 75 per cent = 75% = $\frac{75}{100}$ or $\frac{3}{4}$ or 0.75.
- To convert a fraction or a decimal to a percentage, multiply by 100.
- To convert a percentage to a fraction, write it with a denominator of 100 and simplify.
 $15\% = \frac{15}{100} = \frac{3}{20}$
- To convert a percentage to a decimal, divide by 100.
 $15\% = 15 \div 100 = 0.15$
- To find a percentage of a quantity, write the percentage as a fraction or a decimal, then multiply by the quantity, i.e. $x\%$ of $P = \frac{x}{100} \times P$.

Exercise 2A

Understanding 1–3 3

- Complete the following using the words *multiply* or *divide*.
 - To convert a decimal to a percentage _____ by 100.
 - To convert a percentage to a decimal _____ by 100.
 - To convert a fraction to a percentage _____ by 100.
 - To convert a percentage to a fraction _____ by 100.

74 Chapter 2 Consumer arithmetic

2B Example 6 Decreasing by a given percentage

Decrease \$8900 by 7%.

Solution	Explanation
$\$8900 \times 0.93 = \8277.00	$100\% - 7\% = 93\%$ Write 93% as a decimal (or fraction) and multiply by the amount. Remember to put the units in your answer.

Now you try
Decrease \$2700 by 18%.

- Decrease \$1500 by 5%.
- Decrease \$400 by 10%.
- Decrease \$470 by 20%.
- Decrease \$80 by 15%.
- Decrease \$550 by 25%.
- Decrease \$49.50 by 5%.
- Decrease \$119.50 by 15%.
- Decrease \$47.10 by 24%.

Hit: To decrease by 5%, multiply by $100\% - 5\% = 0.95$.

Example 7 Calculating profit and percentage profit

The cost price for a new car is \$24 780 and it is sold for \$27 600.

- Calculate the profit.
- Calculate the percentage profit, to two decimal places.

Solution	Explanation
$\text{Profit} = \text{selling price} - \text{cost price}$ $= \$27\,600 - \$24\,780$ $= \$2820$	Write the rule. Substitute the values and evaluate.
$\text{Percentage profit} = \frac{\text{profit}}{\text{cost price}} \times 100$ $= \frac{2820}{24\,780} \times 100$ $= 11.38\%$	Write the rule. Substitute the values and evaluate. Round your answer as instructed.

Now you try
The cost price for a new refrigerator is \$888 and it is sold for \$997.

- Calculate the profit.
- Calculate the percentage profit, to two decimal places.

7 Copy and complete the table on profits and percentage profit.

Cost price	Selling price	Profit	Percentage profit
a \$10	\$16		
b \$240	\$300		
c \$15	\$18		
d \$250	\$257.50		
e \$3100	\$2425		
f \$5.50	\$6.49		

Hit: Percentage profit = $\frac{\text{profit}}{\text{cost price}} \times 100$

11 Working programs: differentiated question sets for two ability levels in exercises

12 Puzzles and games: in each chapter provide problem-solving practice in the context of puzzles and games connected with the topic

21 Comparing interest using technology 113

11

4 a Find the total amount of the following investments, using technology.

- i \$6000 at 6% p.a. compounded annually for 3 years
- ii \$6000 at 3% p.a. compounded annually for 5 years
- iii \$6000 at 3.4% p.a. compounded annually for 4 years
- iv \$6000 at 10% p.a. compounded annually for 2 years
- v \$6000 at 5.7% p.a. compounded annually for 5 years

b Which of the above yields the most interest?

5 a Find the total amount of the following investments, using technology where possible.

- i \$6000 at 6% p.a. simple interest for 3 years
- ii \$6000 at 3% p.a. simple interest for 6 years
- iii \$6000 at 3.4% p.a. simple interest for 7 years
- iv \$6000 at 10% p.a. simple interest for 2 years
- v \$6000 at 5.7% p.a. simple interest for 5 years

b Which of the above yields the most interest?

Problem-solving and reasoning 6, 7 6-8

6 a Determine the total simple and compound interest accumulated on the following.

- i \$4000 at 6% p.a. payable annually for:
 - I 1 year II 2 years III 5 years IV 10 years
- ii \$4000 at 6% p.a. payable biannually for:
 - I 1 year II 2 years III 5 years IV 10 years
- iii \$4000 at 6% p.a. payable monthly for:
 - I 1 year II 2 years III 5 years IV 10 years

b Would you prefer the same rate of compound interest or simple interest if you were investing money and paying off the loan in instalments?

c Would you prefer the same rate of compound interest or simple interest if you were borrowing money?

7 a Copy and complete the following table if simple interest is applied.

Principal	Rate	Overall time	Interest	Amount
\$7000	5 years			\$8750
\$7000		5 years		\$10 500
	10%	3 years	\$900	
	10%	3 years	\$2400	
\$8000	8%	2 years		
\$18 000	9%	2 years		

b Explain the effect on the interest when we double the:

- i rate
- ii period
- iii overall time

8 Copy and complete the following table if compound interest is applied. You may need to use a calculator and trial and error to find some of the missing values.

Principal	Rate	Period	Overall time	Interest	Amount
\$7000	Annually	5 years			\$8750
\$7000	Annually	5 years			\$10 500
\$8000	8%	Fortnightly	2 years		
\$18 000	8%	Fortnightly	2 years		

12 Puzzles and games 119

12

1 Find and define the 10 terms related to consumer arithmetic and percentages hidden in this wordfind.

2 How do you stop a bull charging you? Answer the following problems and match the letters to the answers below to find out.

3 How many years does it take \$1000 to double if it is invested at 10% p.a. compounded annually?

4 The chance of Jayden winning a game of cards is said to be 5%. How many consecutive games should Jayden play to be 95% certain he has won at least one of the games played?

Puzzles and games

Wordfind grid:

C	O	M	M	S	S	I	O	N	Q	R	N	
P	S	S	L	E	R	S	T	B	L	D	U	J
H	L	A	A	P	I	E	C	E	W	O	R	R
V	K	N	S	L	A	M	O	N	T	H	L	Y
B	R	U	A	I	O	R	O	S	S	U	B	S
N	E	A	C	Y	K	S	Y	E	T	Y	M	D
M	R	L	O	V	E	R	T	I	W	E	Q	I
S	F	O	R	T	M	I	G	H	T	L	Y	S

Answers for problem 2:

- A: 12 1/2% of \$100
- B: 6% of \$89
- C: \$15 monthly for 2 years
- D: Decrease \$89 by 5%
- E: \$19.47 - \$8.53
- F: 5% of \$89
- G: If 5% = \$8.90 then 100% is?
- H: Increase \$89 by 5%
- I: 12 1/2% as a decimal
- J: \$15.90 v \$12.42
- K: \$50 - \$49.73
- L: 10% of \$76
- M: \$4.68 to the nearest 5 cents

13 NEW Chapter checklist: a checklist of the learning intentions for the chapter, with example questions

14 Chapter reviews: with short-answer, multiple-choice and extended-response questions; questions that are 'Gold Star' (extension) are clearly signposted

13

480 Chapter 7: Geometry

Chapter checklist

A version of this checklist that you can print out and complete can be downloaded from your Interactive Textbook.

29 I can find unknown angles in parallel lines. e.g. Find the values of the pronumerals in this diagram and give reasons for your answers.

30 I can prove that two lines are parallel. e.g. Decide, with reasons, whether the given pair of lines are parallel.

31 I can find unknown angles in any type of triangle. e.g. Find the value of x in this triangle.

32 I can use the exterior angle theorem to find unknown angles. e.g. Use the exterior angle theorem to find the value of x in this diagram.

33 I can find an unknown angle in a quadrilateral. e.g. Find the value of x in this quadrilateral.

34 I can find an unknown angle in a special quadrilateral. e.g. Find the value of x in this kite.

35 I can find an angle sum of a polygon and an unknown angle in a polygon. e.g. Find the value of x in this pentagon after finding the angle sum.

36 I can find the internal angle in a regular polygon. e.g. Find the size of an internal angle inside a regular heptagon.

37 I can choose a test and write a congruence statement for a pair of congruent triangles. e.g. Write a congruence statement and the test to prove congruence for this pair of triangles.

14

246 Chapter 4: Probability

Chapter review

Short-answer questions

4A 1 A fair 6-sided die is rolled once. Find:

- a $P(4)$
- b $P(\text{even})$
- c $P(\text{at least } 3)$

4A 2 A letter is chosen from the word INTEREST. Find the probability that the letter will be:

- a I
- b E
- c a vowel
- d not a vowel
- e E or T
- f a vowel

4A 3 An engineer inspects 20 houses in a street for cracks. The results are summarised in this table.

Number of cracks	0	1	2	3	4
Frequency	8	5	4	2	1

a From these results, estimate the probability that the next house inspected in the street will have the following number of cracks.

- i 0
- ii 1
- iii 2
- iv 3
- v 4

b Estimate the probability that the next house will have:

- i at least 1 crack
- ii more than 2 cracks

4B/C 4 Of 36 people, 18 have an interest in cars, 11 have an interest in homewares and 6 have an interest in both cars and homewares.

- a Complete this Venn diagram.
- b Complete this two-way table.

Venn diagram: Cars (A), Homewares (B), 6 in intersection.

Two-way table:

	C	C'	
H	6		
H'			

c State the number of people from the group who do not have an interest in either cars or homewares.

d If a person is chosen at random from the group, find the probability that the person will:

- i have an interest in cars and homewares
- ii have an interest in homewares only
- iii not have any interest in cars

4B/C 5 All 26 birds in an aviary have clipped wings and/or a tag. In total, 18 birds have tags, 14 have clipped wings and 6 have both clipped wings and a tag.

- a Find the number of birds that have only clipped wings.
- b Find the probability that a bird chosen at random will have a tag only.

40 6 For these probability diagrams, find $P(A \cap B)$.

a

b

INTERACTIVE TEXTBOOK FEATURES

15 NEW Workspaces: almost every textbook question – including all working-out – can be completed inside the Interactive Textbook by using either a stylus, a keyboard and symbol palette, or uploading an image of the work

16 NEW Self-assessment: students can then self-assess their own work and send alerts to the teacher. See the Introduction on page x for more information

17 Interactive question tabs can be clicked on so that only questions included in that working program are shown on the screen

18 HOTmaths resources: a huge catered library of widgets, HOTsheets and walkthroughs seamlessly blended with the digital textbook

19 Desmos graphing calculator, scientific calculator and geometry tool are always available to open within every lesson

20 Scorcher: the popular competitive game

21 Worked example videos: every worked example is linked to a high-quality video demonstration, supporting both in-class learning and the flipped classroom

22 A revised set of **differentiated auto-marked practice quizzes** per lesson with saved scores

23 Auto-marked maths literacy activities test students on their ability to understand and use the key mathematical language used in the chapter

24 Auto-marked prior knowledge pre-test (the 'Warm-up quiz' of the print book) for testing the knowledge that students will need before starting the chapter

25 NEW Auto-marked diagnostic pre-test for setting a baseline of knowledge of chapter content

26 Auto-marked progress quizzes and chapter review multiple-choice questions in the chapter reviews can now be completed online

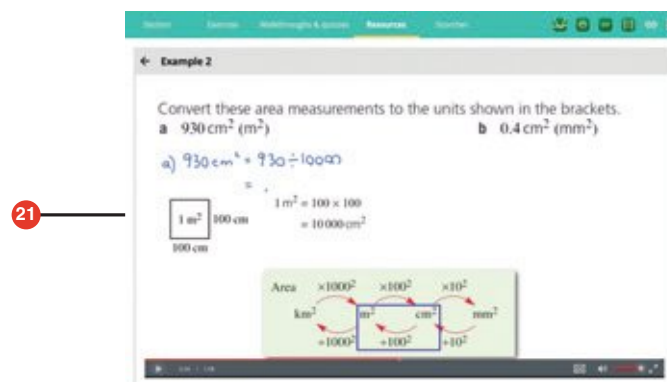
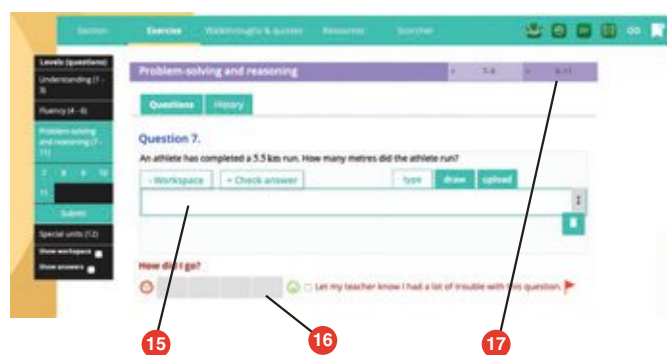



DOWNLOADABLE PDF TEXTBOOK

- 27 In addition to the Interactive Textbook, a **PDF version of the textbook** has been retained for times when users cannot go online. PDF search and commenting tools are enabled.

ONLINE TEACHING SUITE

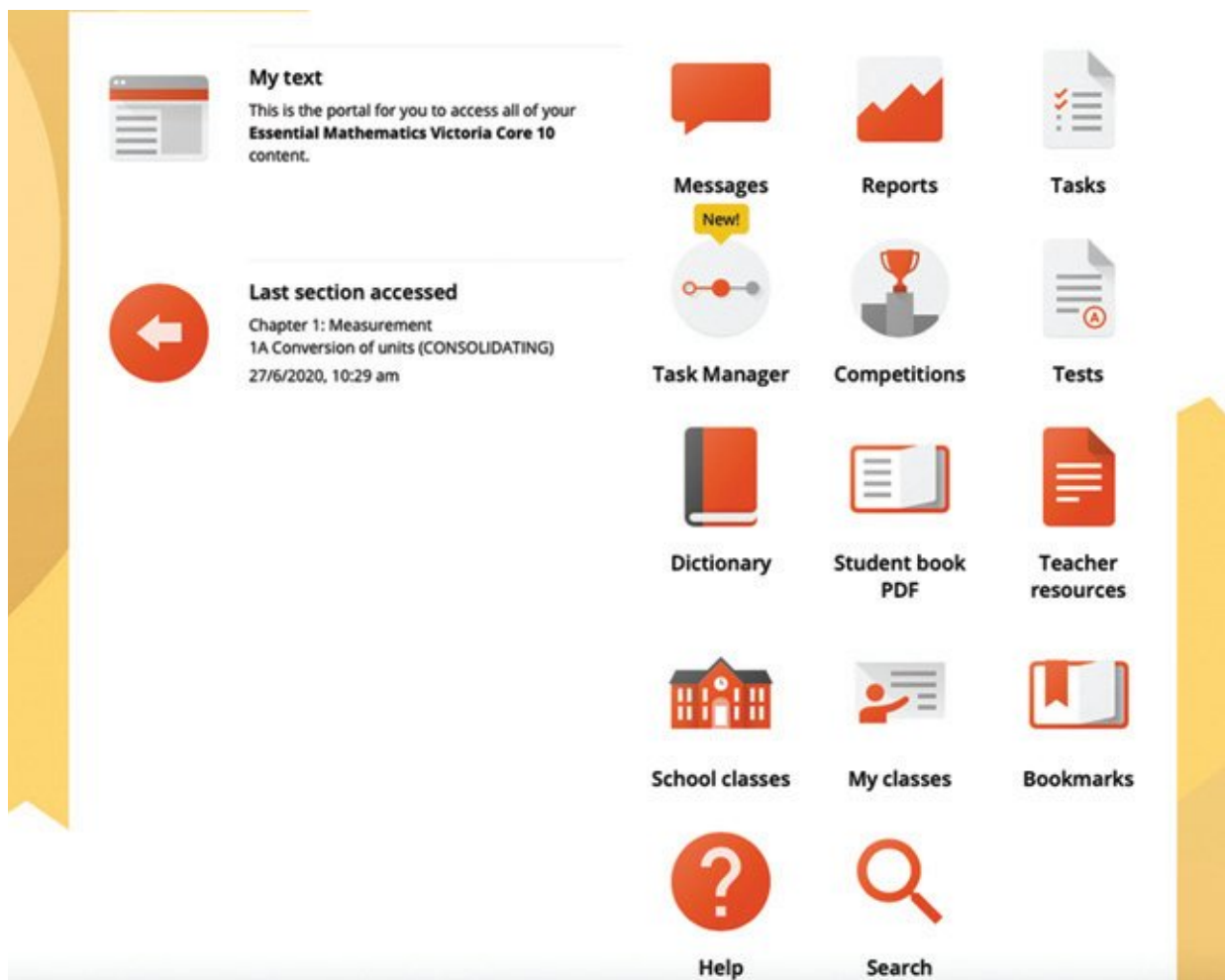
- 28 **Learning Management System** with class and student analytics, including reports and communication tools
- 29 **NEW Teacher view of students' work and self-assessment** allows the teacher to see their class's workout, how students in the class assessed their own work, and any 'red flags' that the class has submitted to the teacher
- 30 **Powerful test generator** with a huge bank of levelled questions as well as ready-made tests
- 31 **NEW Revamped task manager** allows teachers to incorporate many of the activities and tools listed above into teacher-controlled learning pathways that can be built for individual students, groups of students and whole classes
- 32 **Worksheets, skillsheets, maths literacy worksheets, and two differentiated chapter tests in every chapter**, provided in editable Word documents
- 33 **NEW More printable resources:** all Pre-tests and Progress quizzes are provided in printable worksheet versions





Chapter 1

Reviewing number

Essential mathematics: why number skills are important

Number skills are essential for trades, professions and many practical tasks. Negative numbers are used for temperatures and in financial calculations. Skills with rates, ratios and fractions are applied in numerous occupations, for example:

- Cooks and chefs regularly make calculations using direct proportion, fractions and ratios when adapting recipes.
- Competitive cyclists select gear ratios to allow the maximum possible acceleration and speed for various race conditions.
- Fishermen and power boat owners mix petrol and oil in a ratio of 50 : 1 for outboard motor fuel.
- Jewellers can mix gold, copper and silver in a ratio of 15 : 4 : 1 for a rose gold ring, necklace or bracelet.
- Builders mix cement, sand and gravel in a ratio of 1 : 2 : 4 for driveway concrete and can mix cement and sand in a ratio of 1 : 3 for swimming pool concrete.

Rate calculations are essential for farmers to efficiently manage water usage. Rates include pump flow rates (litres per second); drip irrigation rates (litres per hour); travelling irrigator rates (acres per hour); and irrigation frequency rates (number of times irrigation occurs per week).



In this chapter

- 1A Adding and subtracting integers (**Consolidating**)
- 1B Multiplying and dividing integers (**Consolidating**)
- 1C Rounding decimals and significant figures
- 1D Rational and irrational numbers (**Consolidating**)
- 1E Adding and subtracting fractions (**Consolidating**)
- 1F Multiplying and dividing fractions (**Consolidating**)
- 1G Ratios (**Consolidating**)
- 1H Rates and direct proportion

Australian Curriculum

NUMBER AND ALGEBRA

Real numbers

Solve problems involving direct proportion. Explore the relationship between graphs and equations corresponding to simple rate problems (ACMNA208)

© Australian Curriculum, Assessment and Reporting Authority (ACARA)

Online resources

A host of additional online resources are included as part of your Interactive Textbook, including HOTmaths content, video demonstrations of all worked examples, auto-marked quizzes and much more.

- 1 Arrange the following mathematical terms under four headings: 'Addition', 'Subtraction', 'Multiplication' and 'Division'.
- | | | | |
|-------------------|----------------|--------------------|---------------------|
| a Sum | b Total | c Less than | d Lots of |
| e Product | f Into | g Take away | h Difference |
| i Add | j Times | k Minus | l More than |
| m Quotient | | | |
- 2 Without using a calculator, find an answer to each of the following.
- | | |
|--|--------------------------------|
| a 16 less 12 | b 24 more than 8 |
| c the difference between 12 and 8 | d increase 45 by 7 |
| e the total of 40, 34 and 0 | f 9 into 45 |
| g the quotient of 63 and 7 | h 480 shared between 12 |
- 3 Evaluate the following.
- | | | | |
|-----------------------|-----------------------|-------------------------|---------------------------|
| a $9 + 47$ | b $135 - 35$ | c $19 - 19$ | d $56 + 89 - 12$ |
| e 9×7 | f $320 \div 4$ | g 17×60 | h $200 - 47 - 100$ |
- 4 Use a number line to find:
- | | | | |
|--------------------|--------------------|-----------------------|-----------------------|
| a $-5 - 7$ | b $12 - 15$ | c $-6 + 9$ | d $-12 + 12$ |
| e $16 - 17$ | f $-4 + 3$ | g $-7 + 4 + 3$ | h $-4 - 4 - 4$ |
- 5 Copy and complete each of the following statements.
- | | | |
|---|---|-------------------------------------|
| a $5 + 5 + 5 = \square \times 5$ | b $-6 - 6 - 6 = \square \times (-6)$ | c $9 - (+10) = 9 \square 10$ |
| d $12 - (-2) = 12 \square 2$ | | |
- 6 The population of Australia in 2050 is projected to be 26 073 258. Round this number to the nearest:
- | | | | |
|--------------|------------------|-------------------|------------------|
| a ten | b hundred | c thousand | d million |
|--------------|------------------|-------------------|------------------|
- 7 Write down the place value of the 5 in each of the following numbers.
- | | | | | | |
|---------------|--------------|---------------|---------------|---------------|----------------|
| a 1256 | b 345 | c 5049 | d 0.56 | e 0.15 | f 9.005 |
|---------------|--------------|---------------|---------------|---------------|----------------|
- 8 Arrange the numbers in each of the following sets in descending order (largest to smallest).
- | | |
|--|---|
| a 2.645, 2.654, 2.465 and 2.564 | b 0.456, 0.564, 0.0456 and 0.654 |
|--|---|
- 9 Evaluate each of the following.
- | | | |
|------------------------|------------------------|-------------------------|
| a $4.26 + 3.73$ | b $3.12 + 6.99$ | c $10.89 - 3.78$ |
|------------------------|------------------------|-------------------------|
- 10 Evaluate:
- | | | |
|---------------------------|---------------------------|---------------------------|
| a 7×0.2 | b 0.3×0.2 | c 2.3×1.6 |
| d 4.2×3.9 | e $14.8 \div 4$ | f $12.6 \div 0.07$ |
- 11 Evaluate each of the following.
- | | | | |
|-----------------------------|---------------------------------|----------------------------|---------------------------------|
| a 0.345×100 | b $3.74 \times 100\ 000$ | c $37.54 \div 1000$ | d $3.7754 \div 100\ 000$ |
|-----------------------------|---------------------------------|----------------------------|---------------------------------|
- 12 Complete these equivalent fractions.
- | | | | |
|---|---|---|---|
| a $\frac{1}{2} = \frac{\square}{12}$ | b $\frac{3}{4} = \frac{\square}{16}$ | c $\frac{5}{6} = \frac{25}{\square}$ | d $\frac{\square}{9} = \frac{2}{18}$ |
|---|---|---|---|
- 13 Find the lowest common denominator for these pairs of fractions.
- | | | |
|--|--|---|
| a $\frac{1}{3}$ and $\frac{1}{5}$ | b $\frac{1}{6}$ and $\frac{1}{4}$ | c $\frac{1}{5}$ and $\frac{1}{10}$ |
|--|--|---|
- 14 Find:
- | | | | |
|--------------------------------------|----------------------------|-------------------------------|---|
| a $\frac{3}{7} + \frac{2}{7}$ | b $2 - \frac{3}{4}$ | c $4 \div \frac{1}{2}$ | d $\frac{3}{4} \times \frac{1}{2}$ |
|--------------------------------------|----------------------------|-------------------------------|---|

1A Adding and subtracting integers

CONSOLIDATING

Learning intentions

- To be able to use a number line for addition and subtraction of integers
- To review the rules for adding and subtracting negative numbers
- To be able to add and subtract a negative integer

Key vocabulary: integer, positive, negative

Integers are the set of positive and negative whole numbers, as well as the number zero.

Being able to work with whole numbers is very important, since whole numbers are used every day for counting, ordering, calculating, measuring and computing.



→ Lesson starter: Naming groups

Here are some groups of numbers. In groups of two or three, use the correct mathematical terms to describe each group. (Suggestions include: 'multiples of', 'factors of', 'integers', 'squares' and 'cubes'.)

- 2, 4, 6, 8, ...
- 1, 4, 9, 16, ...
- 1, 3, 5, 7, 9, ...
- 1, 2, 3, 4, 5, 6, ...
- -1, -2, -3, -4, -5, ...
- 1, 8, 27, 64, ...
- 1, 2, 3, 4, 6 and 12

Key ideas

- **Integers** are the positive and negative whole numbers, including zero: ..., -3, -2, -1, 0, 1, 2, 3, ...
- To add a negative number, you subtract its opposite: $a + (-b) = a - b$
 e.g. $5 + (-7) = 5 - 7$
 $-6 + (-2) = -6 - 2$
- To subtract a negative number, you add its opposite: $a - (-b) = a + b$
 e.g. $5 - (-7) = 5 + 7$
 $-6 - (-2) = -6 + 2$
- Adding or subtracting zero leaves a number unchanged.
 $a + 0 = a$ e.g. $5 + 0 = 5$
 $a - 0 = a$ e.g. $5 - 0 = 5$

Exercise 1A

Understanding

1-3

3

1 Match each of the following sentences to the correct setting out on the right.

- | | |
|--|----------------------|
| a The sum of 5 and 7 | i $5 + (-7)$ |
| b The total of negative 5 and 7 | ii $5 - (-7)$ |
| c The difference between negative 5 and 7 | iii $5 + 7$ |
| d The sum of 5 and negative 7 | iv $7 - (-5)$ |
| e The difference between 5 and negative 7 | v $-5 + 7$ |

2 Match each question on the left to an expression or answer on the right.

- | | |
|-----------------------|---------------------|
| a $10 + (-7)$ | i $-10 - 7$ |
| b $-10 - (-7)$ | ii $-10 + 7$ |
| c $10 - (-7)$ | iii 0 |
| d $-10 + (-7)$ | iv $10 - 7$ |
| e $-10 + 10$ | v $10 + 7$ |

3 True or false?

- a** $18 + 0 = 18$
b $6 - (-4) = 6 + 4$
c $4 - (-2) = 4 - 2$

Fluency

4-8(½)

5-8(½)



Example 1 Using a number line for addition and subtraction of integers

Use a number line to find:

a $-10 + 8$

b $-3 - 5$

Solution

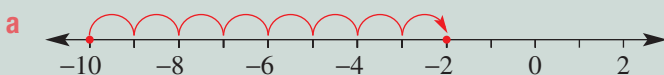

$$-10 + 8 = -2$$

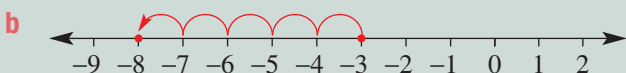

$$-3 - 5 = -8$$

Explanation

Draw a number line showing -10 on it.

Start at -10 and count up (for addition) eight places to finish at -2 .

Draw a number line showing -3 on it.

Count down (for subtraction) five places to -8 .

Now you try

Use a number line to find:

a $-7 + 4$

b $-6 - 4$

- 4 Use the number line below to help you find the answers to the following.

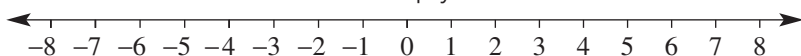

- a** $-6 + 4$ **b** $-6 + 8$ **c** $0 - 3$
d $-1 + 5$ **e** $6 - 10$ **f** $-2 - 3$
g $-1 - 1$ **h** $-3 + 3$ **i** $-3 - 3$

Hint: Move right for addition and left for subtraction.



- 5 Use a number line to evaluate the following.

- a** $9 - 6$ **b** $9 - 7$ **c** $9 - 8$
d $9 - 9$ **e** $9 - 10$ **f** $-9 - 0$
g $-9 + 8$ **h** $-9 - 8$ **i** $-6 - 4$
j $-3 + 12$ **k** $-8 + 6$ **l** $-1 + 12$
m $-12 + 5$ **n** $-10 - 8$ **o** $18 - 19$

- 6 Find:

- a** $4 + 8 - 7$ **b** $5 + 6 + 9$ **c** $-19 - 1$
d $-9 + 8 + 1$ **e** $-12 - 3 + 8$ **f** $8 + 3 - 5$
g $-12 - 12$ **h** $15 + 5 - 15$ **i** $-6 - 5 - 4$

Hint: Work from left to right.



Example 2 Adding a negative integer

Find $17 + (-12)$

Solution

$$\begin{aligned} 17 + (-12) &= 17 - 12 \\ &= 5 \end{aligned}$$

Explanation

Adding a negative is the same as subtraction:
 $17 + (-12) = 17 - 12$

Now you try

Find $12 + (-8)$

- 7 Find:

- a** $9 + (-5)$ **b** $12 + (-16)$ **c** $3 + (-7)$
d $15 + (-24)$ **e** $-9 + (-23)$ **f** $-13 + (-25)$
g $-100 + (-89)$ **h** $56 + (-80)$ **i** $-9 + (-9)$
j $18 + (-18)$ **k** $-245 + (-560)$ **l** $98 + (-155)$
m $-89 + (-78)$ **n** $145 + (-3)$ **o** $-567 + (-237)$

Hint:

$$\begin{aligned} 9 + (-5) &= 9 - 5 \\ -9 + (-23) &= -9 - 23 \end{aligned}$$



Example 3 Subtracting a negative integer

Find $-13 - (-9)$

Solution

$$\begin{aligned} -13 - (-9) &= -13 + 9 \\ &= -4 \end{aligned}$$

Explanation

Subtracting a negative is the same as addition:
 $-13 - (-9) = -13 + 9$

Now you try

Find $-18 - (-10)$

1A

8 Find:

a $-8 - (-6)$

b $-5 - (-9)$

c $7 - (-6)$

d $2 - (-7)$

e $12 - (-12)$

f $-34 - (-34)$

g $-35 - (-7)$

h $-90 - (-9)$

i $90 - (-90)$

j $-68 - (-70)$

k $-90 - (-87)$

l $234 - (-6)$

m $670 - (-85)$

n $-6 - (-100)$

o $-230 - (-240)$

Hint: $-5 - (-9) = -5 + 9$ 

Problem-solving and reasoning

9, 10

9-10(½), 11, 12

9 Simplify each of these using the previous rules.

a $-9 - 9 - 9$

b $-23 - (-8) + 12$

c $50 - 46 - (-6)$

d $24 - (-8) + (-6)$

e $-20 - (-5) - (-15)$

f $-18 - (-6) + (-12)$

g $-90 - (-89) - 90$

h $125 - 35 - (-35)$

Hint: Work from left to right.



10 Copy and complete each of the following statements.

a $\square + 6 = 8$

b $-6 + \square = 5$

c $12 - \square = 15$

d $-9 + \square = -10$

e $13 - \square = 20$

f $10 - \square = -1$

Hint: Try using a number line.



11 What must be added to each of the following to obtain a final result of zero?

a 8

b $-7 + 3$

c $-8 - 5$

d -124

e 19

f 0

g $12 - 8 + 18$

h -98

i $12 - (-14)$

12 The temperature on a mountain top reaches a maximum of -2°C during the day. By night it has dropped 10°C . What is the night-time temperature?

Magic squares with negatives

—

13

13 In a magic square, each row, column and diagonal add to the same number.

a Copy and complete this magic square.

-8		
	-2	-6
		4

Hint: What does the diagonal add up to?

b Arrange these 9 integers into a 3 by 3 magic square.
 $-13, -10, -7, -4, -1, 2, 5, 8$ and 11

c Complete this 4 by 4 magic square.

5			
0	10		6
-1	4	2	8
		7	-4

1B Multiplying and dividing integers

CONSOLIDATING

Learning intentions

- To know the rules for multiplying and dividing integers with the same or different signs
- To be able to multiply and divide with negative integers
- To be able to find the square and cube of negative integers
- To be able to apply order of operations to problems involving negative integers

Key vocabulary: integer, square, cube

Multiplication is a way of writing repeated addition. It is possible to develop rules for multiplying and dividing with negative integers.

→ Lesson starter: Repeated addition

1 Write each of the following as a multiplication before finding the answer.

- a $4 + 4 + 4$
 b $(-4) + (-4) + (-4)$
 c $5 + 5 + 5 + 5$
 d $(-5) + (-5) + (-5) + (-5)$
 e $(-7) + (-7) + (-7) + (-7) + (-7)$
 f $(-8) + (-8)$

2 Use your results from above to answer these divisions.

- a $12 \div 4$ b $-12 \div (-4)$
 c $-12 \div 3$ d $-20 \div 4$
 e $-20 \div (-5)$ f $20 \div 5$
 g $-35 \div (-7)$ h $-35 \div 5$
 i $-16 \div (-8)$

3 What can you conclude about dividing a negative number by:

- a a positive number?
 b a negative number?



Key ideas

- When multiplying or dividing two numbers with the same sign, the answer is a positive number.
 $+ \times + = +$ $+ \div + = +$
 $- \times - = +$ $- \div - = +$
 e.g. $-5 \times (-4) = 20$ and $-18 \div (-6) = 3$
- When multiplying or dividing two numbers with different signs, the answer is a negative number.
 $+ \times - = -$ $+ \div - = -$
 $- \times + = -$ $- \div + = -$
 e.g. $-5 \times 4 = -20$ and $18 \div (-6) = -3$
- The **square** of a number is the number multiplied by itself, e.g. $5^2 = 5 \times 5$. The **cube** of a number is the product of a number multiplied by itself twice, e.g. 7^3 is $7 \times 7 \times 7$.
- To square a negative number, use brackets.
 For example, $(-7)^2 = -7 \times (-7) = 49$
 Note that $-7^2 = -49$

1B

- For cube numbers $-2^3 = (-2)^3 = -8$
since $-2 \times (-2) \times (-2) = -8$
- Order of operations
 - Deal with brackets first
 - Do multiplication and division next, working from left to right
 - Do addition and subtraction last, working from left to right

Exercise 1B

Understanding

1-3

3

- 1 Complete the following statements.
 - a A negative number multiplied by a negative number equals a _____ number.
 - b A negative number multiplied by a positive number equals a _____ number.
 - c A negative number divided by a negative number equals a _____ number.
 - d A positive number divided by a negative number equals a _____ number.
 - e A negative number divided by a positive number equals a _____ number.

- 2 Without actually finding the answer to any of these questions, decide whether the answer to each would be a positive or a negative number.

a $2 \times (-8)$	b $78 \times (-1)$
c $56 \div (-2)$	d $-90 \div (-10)$
e 8×12	f $-18 \times (-9)$

- 3 Answer true (T) or false (F) to the following.

a $(-3)^2 = 9$	b $-3^2 = 9$	c $-2^3 = (-2)^3$
----------------	--------------	-------------------

Fluency

4-7(½)

4-7(½)



Example 4 Multiplying with negatives

Find the value of:

a $-6 \times (-7)$

b $8 \times (-12)$

Solution**Explanation**

a $-6 \times (-7) = 42$

The product of two negative numbers gives a positive answer.

$$- \times - = +$$

b $8 \times (-12) = -96$

The product of a positive number and a negative number results in a negative answer.

$$+ \times - = -$$

Now you try

Find the value of:

a $-8 \times (-4)$

b -5×7

1B

6 Perform the following divisions. Use a calculator if necessary.

a $18 \div (-2)$

b $-36 \div (-6)$

c $-100 \div (-10)$

d $-50 \div 5$

e $-6 \div (-2)$

f $-10 \div (-2)$

g $-50 \div (-25)$

h $16 \div (-16)$

i $24 \div (-3)$

j $-100 \div (-4)$

k $312 \div (-3)$

l $-45 \div (-9)$

m $185 \div (-5)$

n $-428 \div 2$

o $-156 \div (-12)$

Hint: $+++=+$ $--=-+$ $+-=-$ $-+=-$ 

Example 7 Applying the order of operations

Find the value of $9 \times (-8) + (5 - 12)$

Solution

Explanation

$$9 \times (-8) + (5 - 12)$$

Work out the value of the brackets first: $(5 - 12) = (-7)$

$$= 9 \times (-8) + (-7)$$

Multiplication is next: $9 \times (-8) = -72$

$$= -72 + (-7)$$

The addition of a negative is the same as subtraction:

$$= -79$$

$$-72 + (-7) = -72 - 7$$

Now you try

Find the value of $8 \div (-2) \times (-8 + 5)$

7 Follow the order of operations and evaluate:

a $(7 - 3) \times 4$

b $(4 + 9) \times (-2)$

c $(6 - 2) \times (-3)$

d $-6 + 4 \times (-2)$

e $10 \div (-2) \times 4$

f $(-5 - 2) \times 4$

g $6 \times (-3) \times 4$

h $-21 \div 7 + (-5)$

i $-45 - 9 \times 5$

j $(4 - 6) \times (7 - 12)$

k $(15 - 9) \times (3 - 7)$

l $9 + 9 \times (-3)$

m $-(3 - 12)$

n $10 - 9 \times 4$

Hint: The order of operations:

- brackets first, following the order of operations within them
- then \times and \div , working from left to right
- then $+$ and $-$, working from left to right.



Problem-solving and reasoning

8, 9

10–12

8 Copy and complete:

a $-5 \times \square = -35$

b $\square \div (-4) = 8$

c $-10 \times \square = 200$

d $17 \times \square = -68$

e $34 \div \square = -34$

f $-6 \times \square = -36$

g $\square \div 9 \times (-3) = 3$

h $15 \div \square \div 3 = -1$

i $-15 \times \square = 225$

9 The sum of two numbers is -3 and their product is -10 . What are the two numbers?

10 Give the value of two different numbers that when squared each produce an answer of:

a 144

b 64

c 10 000

11 Explain why $-5 \times 4 \div (-3)$ produces a positive answer.

12 Decide whether each of the following would produce a positive or a negative answer.

a $-6 \times (-4) \times 5$

b $-12 \div 4 \times 9 \div (-3)$

c $-8 \div (-2) \times 5 \times (6 - 9)$

d $(-3)^4$

e $(-1)^{201}$

f $-(-5)^3$



Substitutions involving negatives

—

13



13 Evaluate these expressions by substituting $a = -2$, $b = 6$ and $c = -3$.

Check that you can get the same answer with a calculator.

a $a^2 - b$

b $a - b^2$

c $2c + a$

d $b^2 - c^2$

e $a^3 + c^2$

f $3b + ac$

g $c - 2ab$

h $abc - (ac)^2$



1C Rounding decimals and significant figures

Learning intentions

- To know how to round a number to a required number of decimal places
- To understand what is meant by significant figures
- To be able to round a number to a required number of significant figures

Key vocabulary: decimal places, critical digit, significant figure

Numbers with and without decimal places can be rounded. The time for a 100 m sprint race, for example, might be 9.94 seconds, correct to two decimal places.

Another way of rounding numbers is to use significant figures. The number of cubic metres of gravel required for a road, for example, might be calculated as 3485 but is rounded to 3500. This number is written using two significant figures.



→ Lesson starter: In the middle

For each number given on the left, decide which of the two numbers on the right it is closest to.

- | | | |
|---|--------|------------------|
| a | 84 | 80 or 90 |
| b | 856 | 800 or 900 |
| c | 856 | 850 or 860 |
| d | 0.599 | 0.5 or 0.6 |
| e | 1.2099 | 1.2 or 1.3 |
| f | 1.2099 | 1.20 or 1.21 |
| g | 89 543 | 89 000 or 90 000 |
| h | 0.035 | 0.03 or 0.04 |

Key ideas

- To round a number to a required number of **decimal places** (number of digits after the decimal point):
 - Locate the digit in the required decimal place.
 - Round down (leave as is) if the next digit (**critical digit**) is 4 or less.
 - Round up (increase by 1) if the next digit is 5 or more.

Critical digit



For example:

- To two decimal places, 1.543 rounds to 1.54 and 32.9283 rounds to 32.93.
- To one decimal place, 0.248 rounds to 0.2 and 0.253 rounds to 0.3.

- To round a number to a required number of **significant figures**:
 - Locate the first *non-zero* digit counting from left to right.
 - From this first significant digit, count out the number of digits, including zeros.
 - Stop at the required number of digits and round this last digit.
 - Replace any non-significant digits to the left of a decimal point with a zero.

For example, these numbers are all rounded to 3 significant figures:

$$2.5391 \approx 2.54 \quad 0.002713 \approx 0.00271 \quad 568\,810 \approx 569\,000$$

Exercise 1C

Understanding

1–4

4

- 1 How many decimal places do each of these numbers have?
 a 1.467 b 146.1 c 0.08 d 47 900
- 2 How many significant figures do each of these numbers have?
 a 0.46 b 21.46 c 0.08 d 4906
- 3 In the following, the critical digit is circled. Use this to state if you round the previous digit down (leave as is) or up.
 a 2.75(4)37 b 0.87(7)2 c 21.5(5)4
- 4 Choose the correct answer if the first given number is rounded to three significant figures.
 a 32 124 is rounded to 321, 3210 or 32 100
 b 431.92 is rounded to 431, 432 or 430
 c 5.8871 is rounded to 5.887, 5.88 or 5.89
 d 0.44322 is rounded to 0.44, 0.443 or 0.44302
 e 0.0019671 is rounded to 0.002, 0.00197 or 0.00196

Hint: Count the digits starting from the first non-zero digit. These are the significant ones.



Fluency

5–6(½), 7, 8

5–6(½), 7, 8, 9(½)



Example 8 Rounding to a number of decimal places

Round each of these to two decimal places.

- a 256.1793 b 0.04459 c 4.8972

Solution

Explanation

a $256.1793 \approx 256.18$

$256.\underline{1}793$

The number after the second decimal place is 9, so round up (increase the 7 by 1).

b $0.04459 \approx 0.04$

$0.\underline{0}4459$

The number after the second decimal place is 4, so round down.

Continued on next page

1C

c $4.8972 \approx 4.90$

$4.\underline{8}972$

The number after the second decimal place is 7, so round up.

89 rounds to 90

Now you try

Round each of these to two decimal places.

a 107.3874

b 0.0321

c 2.7956

5 Round each of the following numbers to two decimal places.

a 17.962

b 11.082

c 72.986

d 47.859

e 63.925

f 23.807

g 804.5272

h 500.5749

i 821.2749

j 5810.2539

k 1004.9981

l 2649.9974

Hint: The critical digit will be the third decimal place.

**Example 9 Rounding to a number of significant figures**

Round each of these numbers to two significant figures.

a 2567

b 23 067.453

c 0.04059

Solution**Explanation**

a $2567 \approx 2600$

$\begin{array}{c} 2567 \\ \uparrow \uparrow \\ \text{significant digits} \end{array}$

The next digit is 6, so round up.

Replace last 2 digits with zeros to maintain place value.

b $23\,067.453 \approx 23\,000$

$\begin{array}{c} 23067.453 \\ \uparrow \uparrow \\ \text{significant digits} \end{array}$

The next digit is 0, so round down.

Replace the remaining digits, in front of the decimal point, with zeros.

c $0.04059 \approx 0.041$

Locate the first non-zero digit and count two digits:

$\begin{array}{c} 0.04059 \\ \uparrow \uparrow \\ \text{significant digits} \end{array}$

The next digit is 5, so round up.

No extra zeros are needed, as they are after the decimal point.

Now you try

Round each of these numbers to two significant figures.

a 3472

b 1792.41

c 0.00226

6 Round each of these numbers to two significant figures.

- a** 2436 **b** 35 057.4 **c** 0.06049
d 34.024 **e** 107 892 **f** 0.00245
g 2.0745 **h** 0.7070 **i** 4706
j 59 134 **k** 0.4567 **l** 1.0631

Hint: Start at the first non-zero digit on the left.



7 Copy and complete this table.

	Number	Rounded to two decimal places	Rounded to two significant figures
a	1.4638		
b	0.0936		
c	23.7124		
d	0.00783		
e	100.465		

8 Round these numbers to the nearest whole number.

- a** 6.814 **b** 73.148 **c** 129.94 **d** 36 200.49

9 Round these numbers to one significant figure.

- a** 32 000 **b** 194.2 **c** 0.0492
d 0.0006413 **e** 4793 **f** 890
g 0.89 **h** 0.000304 **i** 0.95

Hint: $48.06 = 50$ to one significant figure.
 $4730 = 5000$ to one significant figure.
 $0.638 = 0.6$ to one significant figure.



Problem-solving and reasoning

10–12

11–14



Example 10 Estimating using significant figures

Estimate the answer to $27 + 1329.5 \times 0.0064$ by rounding each number in the problem to one significant figure. Use your calculator to check how reasonable your answer is.

Solution

$$\begin{aligned}
 &27 + 1329.5 \times 0.0064 \\
 &\approx 30 + 1000 \times 0.006 \\
 &= 30 + 6 \\
 &= 36
 \end{aligned}$$

The estimated answer is reasonable.

Explanation

Round each number to one significant figure and evaluate.
 Recall multiplication occurs before addition.

By calculator (to 1 d.p.):
 $27 + 1329.5 \times 0.0064 = 35.5$

Now you try

Estimate the answer to $32 - 117 \div 5.2$ by rounding each number in the problem to one significant figure. Use your calculator to check how reasonable your answer is.



10 Estimate the answers to the following by rounding each number in the problem to one significant figure. Check how reasonable your answer is with a calculator.

- a** $567 + 3126$ **b** $795 - 35.6$ **c** 97.8×42.2
d $965.98 + 5321 - 2763.2$ **e** $4.23 - 1.92 \times 1.827$ **f** $17.43 - 2.047 \times 8.165$
g $0.0704 + 0.0482$ **h** 0.023×0.98 **i** $0.38 \div 1.9$

1C

- 11 An electronic timer records the time for a running relay between two teams, A and B. Team A's time is 54.283 seconds and team B's time is 53.791 seconds. Find the difference in the times for teams A and B if the times were written down using:
- a one decimal place
 - b four significant figures
 - c two significant figures
 - d one significant figure



- 12 One tonne (1000 kg) of soil is to be equally divided between 7 garden beds. How much soil does each garden bed get? Write your answer in tonnes rounded to the nearest kilogram.
- 13 A scientific experiment uses very small amounts of magnesium (0.0025 g) and potassium (0.0062 g). Why does it make sense to use two significant figures instead of two decimal places when recording numbers in a situation like this?



- 14 Should 2.14999 be rounded down or up if it is to be rounded to one decimal place? Give reasons.



n th decimal place and π

—

15, 16

- 15 $\frac{2}{11}$ can be written as 0.18181818 correct to eight decimal places.
- a Using the decimal pattern described, find the digit in the:
 - i 20th decimal place
 - ii 45th decimal place
 - iii 1000th decimal place
 - b Express $\frac{1}{7}$ as a decimal correct to 13 decimal places.
 - c Using the decimal pattern from part b find the digit in the:
 - i 20th decimal place
 - ii 45th decimal place
 - iii 1000th decimal place
- 16 π is a decimal that is non-terminating and has no pattern. $\pi = 3.141592653\dots$
- a How many decimal places can you remember?
 - b Quiz yourself and your classmates.
 - c Use the internet to find π correct to 100 decimal places.

1D Rational and irrational numbers

CONSOLIDATING

Learning intentions

- To know the difference between rational and irrational numbers
- To be able to convert between fractions and decimals
- To know the notation for recurring decimals
- To be able to compare fractions using a common denominator

Key vocabulary: real numbers, rational numbers, irrational numbers, numerator, denominator, proper fraction, improper fraction, mixed number, highest common factor, recurring decimal, equivalent fractions

Rational numbers are any numbers that can be written as a fraction in the form $\frac{a}{b}$, where a and b are integers and $b \neq 0$. Pythagoras and his followers discovered around 500 BCE that not all numbers are rational. Pi (π) and $\sqrt{2}$ are examples of these numbers. When written as decimals, they do not terminate or repeat. We call them irrational numbers.

This is $\sqrt{2}$ to 100 decimal places:

1.4142135623730950488016887
2420969807856967187537694
8073176679737990732478462
1070388503875343276415727

→ Lesson starter: The real number system

Copy the diagram on the right and insert these words correctly: rational, irrational, real, integers, counting.

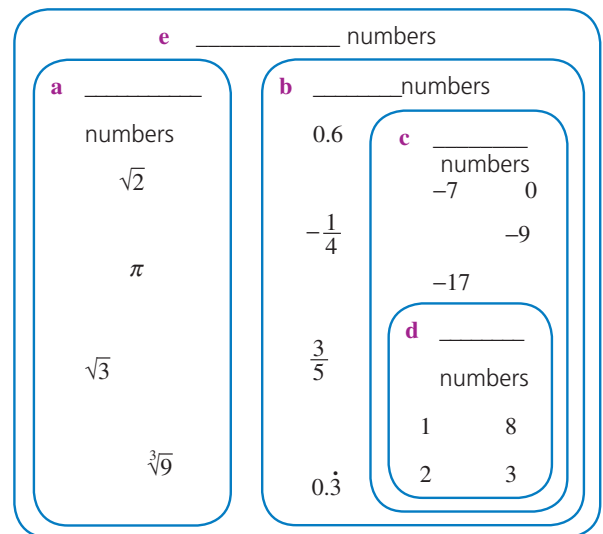

Key ideas

- The **real numbers** (any positive or negative number or zero) can be classified as rational or irrational numbers.

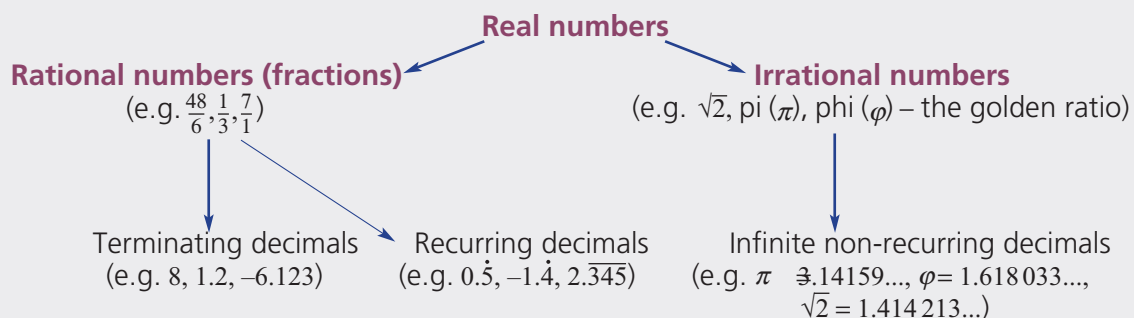

1D

- An infinite decimal is one where the decimal places continue forever.
- **Equivalent fractions** have the same value. For example: $\frac{2}{3} = \frac{6}{9}$
- Fractions can be simplified by dividing the **numerator** and **denominator** by their **highest common factor** (HCF).
- If $\frac{a}{b}$ is a **proper fraction**, then $a < b$. For example: $\frac{2}{7}$
- If $\frac{a}{b}$ is an **improper fraction**, then $a \geq b$. For example: $\frac{10}{3}$
- A **mixed number** is written as a whole number plus a proper fraction. For example: $2\frac{3}{5}$
As a mixed number $\frac{11}{3}$ is $3\frac{2}{3}$ and as an improper fraction $4\frac{1}{5}$ is $\frac{21}{5}$
- Fractions can be compared using a common denominator. This should be the lowest common multiple of both denominators.
- A dot or bar is used to show a pattern in a **recurring decimal** number.
For example: $\frac{1}{6} = 0.16666\dots = 0.1\dot{6}$ or $\frac{3}{11} = 0.272727\dots = 0.2\overline{7}$

Exercise 1D

Understanding

1–3

1

1 Answer the following as true or false.

- a $\sqrt{3}$ is an irrational number.
- b $\sqrt{4}$ is an irrational number.
- c $0.\dot{3}$ is a rational number.
- d $\frac{4}{5}$ is a rational number.

Hint: An irrational number as a decimal is never-ending and has no pattern.



2 State whether each of the following is a proper fraction, improper fraction or mixed number.

- a $\frac{2}{3}$
- b $4\frac{1}{7}$
- c $\frac{11}{6}$
- d $\frac{1}{5}$

3 Write each of these in the form $\frac{a}{b}$.

- a 0.7
- b 0.3
- c $1\frac{1}{2}$
- d $2\frac{1}{3}$

Fluency

4, 5, 6–9(½)

4, 5, 6–9(½)



Example 11 Identifying rational numbers

Choose the rational numbers in the following list.

$\sqrt{9}, \sqrt{2}, 0.6, \pi, -\frac{3}{4}$

Solution

 $\sqrt{9}, 0.6$ and $-\frac{3}{4}$ are rational numbers.

Explanation

$\sqrt{9} = 3 = \frac{3}{1} \therefore$ rational (a fraction)

$0.6 = \frac{6}{10} \therefore$ rational

$-\frac{3}{4}$ is also rational.

 π and $\sqrt{2}$ are infinite non-recurring decimals.

Now you try

Choose the rational numbers in the following list.

$2\pi, \frac{5}{8}, 0.32, \sqrt{3}, -\sqrt{25}$

4 Which of the following are rational numbers?

a 0.1

b 20%

c $6\frac{1}{4}$

d $\frac{2}{5}$

e $\frac{2}{3}$

f 0.001

g $\sqrt{64}$

h $\sqrt{7}$

i 4^2

j π

k $0.\dot{2}$

l $\sqrt{11}$

Hint: Rational numbers can be written as a fraction.



Example 12 Converting between mixed numbers and improper fractions

Express

a $\frac{11}{4}$ as a mixed number

b $2\frac{3}{5}$ as an improper fraction

Solution

Explanation

a $\frac{11}{4} = 2\frac{3}{4}$

4 divides into 11, 2 whole times. $2 \times 4 = 8$, leaving a remainder of 3.

b $2\frac{3}{5} = \frac{13}{5}$

To obtain the numerator $2 \times 5 + 3 = 13$.

Now you try

Express

a $\frac{17}{5}$ as a mixed number

b $2\frac{1}{4}$ as an improper fraction

1D

5 Complete the following conversions.

a Express each of the following improper fractions as mixed numbers.

i $\frac{12}{5}$

ii $\frac{17}{6}$

iii $\frac{23}{4}$

iv $\frac{9}{8}$

b Express each of the following mixed numbers as improper fractions.

i $3\frac{1}{5}$

ii $6\frac{2}{7}$

iii $4\frac{4}{5}$

iv $10\frac{3}{8}$



Example 13 Writing fractions as decimals

Write $4\frac{3}{8}$ as a decimal.

Solution

$$\begin{array}{r} 0.375 \\ 8 \overline{) 3.000} \\ \underline{24} \\ 60 \\ \underline{56} \\ 40 \\ \underline{40} \\ 0 \end{array}$$

$$4\frac{3}{8} = 4.375$$

Explanation

Find a decimal for $\frac{3}{8}$ by dividing 8 into 3 using the short division algorithm.

Now you try

Write $2\frac{5}{16}$ as a decimal.

6 Write these fractions as decimals.

a $\frac{11}{4}$

b $\frac{7}{20}$

c $3\frac{2}{5}$

d $\frac{15}{8}$

e $2\frac{5}{8}$

f $3\frac{4}{5}$

g $\frac{37}{16}$

h $\frac{7}{28}$

Hint: Use short division.
 $\frac{11}{4}$ means $11 \div 4$



Example 14 Recurring decimals from fractions

Write $\frac{5}{13}$ as a recurring decimal.

Solution

$$\begin{array}{r} 0.3846153 \\ 13 \overline{) 5.000000} \\ \underline{39} \\ 110 \\ \underline{116} \\ 40 \\ \underline{39} \\ 10 \\ \underline{9} \\ 100 \\ \underline{91} \\ 90 \\ \underline{91} \\ 0 \end{array}$$

$$\frac{5}{13} = 0.\overline{384615}$$

Explanation

Divide 13 into 5 and continue until the pattern repeats. Add a bar over the repeating pattern.

Writing $0.38461\dot{5}$ is an alternative.

Now you try

Write $\frac{5}{12}$ as a recurring decimal.

7 Write these fractions as recurring decimals.

a $\frac{3}{11}$

b $\frac{7}{9}$

c $\frac{9}{7}$

d $\frac{7}{12}$

e $\frac{10}{9}$

f $3\frac{5}{6}$

g $7\frac{4}{15}$

h $\frac{29}{11}$

Hint: Check using your calculator.



**Example 15 Writing decimals as fractions**

Write these decimals as fractions.

a 0.24

b 2.385

Solution**Explanation**

$$\begin{aligned} \mathbf{a} \quad 0.24 &= \frac{24}{100} \\ &= \frac{6}{25} \end{aligned}$$

Write as a fraction using the smallest place value (hundredths) and then simplify by dividing by the HCF of 4.

$$\begin{aligned} \mathbf{b} \quad 2.385 &= \frac{2385}{1000} & \text{OR} & \quad 2 \frac{385}{1000} \\ &= \frac{477}{200} & & \quad = 2 \frac{77}{200} \\ &= 2 \frac{77}{200} \end{aligned}$$

The smallest place value is thousandths.

Simplify to an improper fraction or a mixed number.

Now you try

Write these decimals as fractions.

a 0.45

b 3.225

8 Write these decimals as fractions.

a 0.35

b 0.06

c 3.7

d 0.56

e 1.07

f 0.075

g 3.32

h 7.375

i 2.005

j 10.044

k 6.45

l 2.101

Hint: Divide by 100 when there are two decimal places.

**Example 16 Comparing fractions**

Decide which is the larger fraction of the following.

$\frac{7}{12}$ or $\frac{8}{15}$

Solution**Explanation**

LCM of 12 and 15 is 60.

$$\frac{7}{12} = \frac{35}{60} \text{ and } \frac{8}{15} = \frac{32}{60}$$

$$\therefore \frac{7}{12} > \frac{8}{15}$$

Find the lowest common multiple of the two denominators (lowest common denominator).

Write each fraction as an equivalent fraction using the common denominator. Then compare numerators (i.e. $35 > 32$) to determine the larger fraction.**Now you try**

Decide which is the larger fraction of the following.

$\frac{4}{9}$ or $\frac{5}{12}$

9 Decide which is the larger fraction in the following pairs.

a $\frac{3}{4}$, $\frac{5}{6}$

b $\frac{13}{20}$, $\frac{3}{5}$

c $\frac{7}{10}$, $\frac{8}{15}$

d $\frac{5}{12}$, $\frac{7}{18}$

e $\frac{7}{16}$, $\frac{5}{12}$

f $\frac{26}{35}$, $\frac{11}{14}$

g $\frac{7}{12}$, $\frac{19}{30}$

h $\frac{7}{18}$, $\frac{11}{27}$

Hint: First write both fractions using a common denominator.



1D

Problem-solving and reasoning

10–12

11, 13, 14

10 Express the following quantities as simplified fractions.

a \$45 out of \$100

b 12 kg out of 80 kg

c 64 baskets out of 90 shots in basketball

d 115 mL out of 375 mL

11 These sets of fractions form a pattern. Find the next two fractions in the pattern.

a $\frac{1}{3}, \frac{5}{6}, \frac{4}{3}, \frac{\square}{\square}, \frac{\square}{\square}$

b $\frac{6}{5}, \frac{14}{15}, \frac{2}{3}, \frac{\square}{\square}, \frac{\square}{\square}$

c $\frac{2}{3}, \frac{3}{4}, \frac{5}{6}, \frac{\square}{\square}, \frac{\square}{\square}$

d $\frac{1}{2}, \frac{4}{7}, \frac{9}{14}, \frac{\square}{\square}, \frac{\square}{\square}$

12 The 'Weather forecast' website says there is a 0.45 chance that it will rain tomorrow. The 'Climate control' website says that the chance of rain is $\frac{14}{30}$. Which website gives the least chance that it will rain?

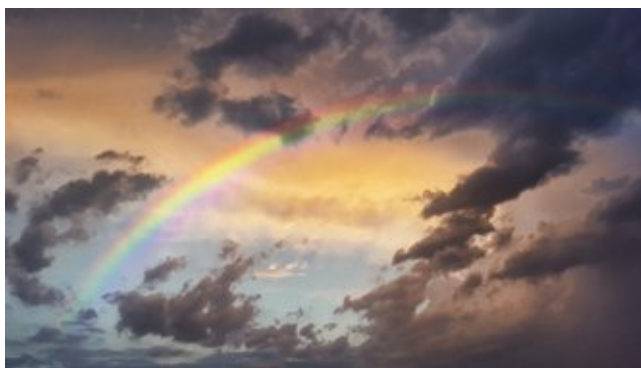

13 A jug has 400 mL of $\frac{1}{2}$ strength orange juice. The following amounts of full strength juice are added to the mix. Find a fraction to describe the strength of the orange drink after the full strength juice is added.

a 100 mL

b 50 mL

c 120 mL

d 375 mL

14 If x is an integer, determine the values that x can take in the following.

a The fraction $\frac{x}{3}$ is a number between (and not including) 10 and 11

b The fraction $\frac{x}{7}$ is a number between (and not including) 5 and 8

c The fraction $\frac{34}{x}$ is a number between 6 and 10

Hint: You may have more than one answer.



Converting recurring decimals to fractions

—

15

15 Here are two examples of how to convert recurring decimals to fractions.

$$0.\dot{6} = 0.6666\dots$$

$$1.2\overline{7} = 1.272727\dots$$

$$\text{Let } x = 0.6666\dots \quad (1)$$

$$\text{Let } x = 1.272727\dots \quad (1)$$

$$10x = 6.6666\dots \quad (2)$$

$$100x = 127.2727\dots \quad (2)$$

$$(2) - (1) \quad 9x = 6$$

$$(2) - (1) \quad 99x = 126$$

$$x = \frac{6}{9} = \frac{2}{3}$$

$$x = \frac{126}{99}$$

$$\therefore 0.\dot{6} = \frac{2}{3}$$

$$\therefore 1.2\overline{7} = \frac{126}{99} = 1\frac{27}{99} = 1\frac{3}{11}$$

Convert these recurring decimals to fractions using the above method.

a 0.8

b 1.2

c $0.8\overline{1}$

d $3.\overline{43}$

1E Adding and subtracting fractions

CONSOLIDATING

Learning intentions

- To understand that common denominators are needed to add or subtract fractions
- To be able to find the lowest common denominator to add or subtract fractions
- To be able to add and subtract mixed numbers

Key vocabulary: equivalent fractions, numerator, denominator, lowest common denominator

As you will remember, fractions represent parts of a whole.

Fractions, like other numbers, can be added and subtracted.

To add or subtract fractions they need to be the same type; that is, they both need to be eighths, quarters, thirds or tenths etc. They need to have a common denominator.

→ Lesson starter: Shade the fraction

Shade the fraction suggested by each of these additions and subtractions.

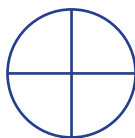
a $\frac{1}{4} + \frac{1}{4} =$ 

b $\frac{1}{4} + \frac{1}{2} =$ 

c $\frac{3}{4} - \frac{1}{2} =$ 

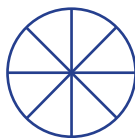
d $\frac{5}{8} + \frac{1}{4} =$ 

e $\frac{1}{2} + \frac{1}{3} =$ 

f $\frac{1}{3} - \frac{1}{4} =$ 

Key ideas

- Equivalent fractions are created by multiplying or dividing both the numerator and the denominator by the same factor.

For example:

$$\frac{3}{4} = \frac{9}{12}$$

$\begin{array}{c} \times 3 \\ \curvearrowright \\ \times 3 \end{array}$

$$\frac{10}{15} = \frac{2}{3}$$

$\begin{array}{c} \div 5 \\ \curvearrowright \\ \div 5 \end{array}$

- To add or subtract fractions, the denominators need to be the same.
 - If the denominators are the same, add/subtract the numerators, keeping the denominator unchanged.

For example: $\frac{3}{5} + \frac{1}{5} = \frac{4}{5}$

- If the denominators are different, find the **lowest common denominator** (LCD) using equivalent fractions. Then add/subtract the numerators, remembering to simplify your answer where possible.

For example: $\frac{1}{2} + \frac{2}{3} = \frac{3}{6} + \frac{4}{6}$ The LCD of halves and thirds is sixths.

$$= \frac{7}{6}$$

$$= 1\frac{1}{6}$$

Exercise 1E

Understanding

1-4

4

1 Copy and complete these equivalent fractions.

a $\frac{3}{4} = \frac{\square}{16}$

b $\frac{3}{5} = \frac{\square}{10}$

c $\frac{5}{6} = \frac{\square}{18}$

d $\frac{3}{7} = \frac{21}{\square}$

e $\frac{4}{5} = \frac{12}{\square}$

f $\frac{5}{7} = \frac{25}{\square}$

Hint: What you do to the numerator must also be done to the denominator, and vice versa.



2 True or false?

a $\frac{7}{9} + \frac{1}{9} = \frac{8}{9}$

b $\frac{6}{9} - \frac{1}{3} = \frac{5}{6}$

3 Copy and complete.

a $\frac{3}{10} + \frac{2}{5}$
 $= \frac{3}{10} + \frac{\square}{10}$
 $= \frac{\square}{10}$

b $\frac{1}{2} - \frac{3}{8}$
 $= \frac{\square}{8} - \frac{3}{8}$
 $= \frac{\square}{8}$

c $1\frac{1}{2} + \frac{1}{4}$
 $= 1\frac{2}{4} + \frac{1}{4}$
 $= 1\frac{\square}{4}$

4 What is the LCD needed if these fractions are to be added or subtracted?

a $\frac{1}{2}, \frac{1}{3}$

b $\frac{3}{7}, \frac{5}{9}$

c $\frac{3}{10}, \frac{8}{15}$

d $\frac{1}{2}, \frac{3}{8}$

e $\frac{9}{11}, \frac{4}{33}$

f $\frac{5}{12}, \frac{7}{30}$

Hint: The LCD is the lowest common multiple of both denominators.



Fluency

5-7(1/2)

5-7(1/2)



Example 17 Adding and subtracting with same denominators

Find:

a $\frac{5}{11} + \frac{8}{11}$

b $1\frac{3}{8} - \frac{5}{8}$

Solution

Explanation

$$\begin{aligned} \text{a } \frac{5}{11} + \frac{8}{11} &= \frac{13}{11} \\ &= 1\frac{2}{11} \end{aligned}$$

Denominators are the same (elevenths).

Keep the denominator and add the numerators.

Write as a mixed number.

$$\begin{aligned} \text{b } 1\frac{3}{8} - \frac{5}{8} &= \frac{11}{8} - \frac{5}{8} \\ &= \frac{6}{8} \\ &= \frac{3}{4} \end{aligned}$$

Write $1\frac{3}{8}$ as an improper fraction.

Denominators are the same (eighths). Subtract the numerators.

Simplify the answer by dividing by the HCF (2).

Now you try

Find:

a $\frac{3}{7} + \frac{5}{7}$

b $1\frac{1}{5} - \frac{4}{5}$

5 Find:

a $\frac{2}{5} + \frac{1}{5}$

b $\frac{3}{8} + \frac{2}{8}$

c $\frac{9}{10} - \frac{2}{10}$

d $\frac{2}{7} + \frac{2}{7}$

e $\frac{13}{17} - \frac{8}{17}$

f $\frac{3}{5} - \frac{2}{5}$

g $\frac{11}{6} - \frac{1}{6}$

h $\frac{13}{8} - \frac{3}{8}$

i $\frac{4}{5} + \frac{3}{5}$

j $1\frac{1}{5} + \frac{3}{5}$

k $2\frac{2}{3} - \frac{1}{3}$

l $1\frac{1}{8} - \frac{5}{8}$

m $1\frac{1}{10} - \frac{7}{10}$

n $3\frac{1}{4} + 1\frac{1}{4}$

o $2\frac{3}{10} - \frac{9}{10}$

p $3\frac{7}{8} + 2\frac{5}{8}$

Hint: Writing mixed numbers as improper fractions may help.



Example 18 Adding with different denominators

Evaluate $\frac{1}{2} + \frac{3}{5}$.

Solution

Explanation

$$\begin{aligned} &\frac{1}{2} + \frac{3}{5} \\ &= \frac{5}{10} + \frac{6}{10} \\ &= \frac{11}{10} \text{ or } 1\frac{1}{10} \end{aligned}$$

The lowest common multiple of the denominators of 2 and 5 is 10. Rewrite as equivalent fractions using a denominator of 10: $\frac{1 \times 5}{2 \times 5} = \frac{5}{10}$ and $\frac{3 \times 2}{5 \times 2} = \frac{6}{10}$.

Add the numerators.

Now you try

Evaluate $\frac{4}{7} + \frac{1}{3}$.

1E

6 Evaluate the following.

a $\frac{1}{2} + \frac{1}{8}$

b $\frac{1}{2} - \frac{1}{6}$

c $\frac{3}{10} + \frac{1}{5}$

d $\frac{4}{3} - \frac{5}{6}$

e $\frac{3}{2} - \frac{3}{5}$

f $\frac{1}{3} + \frac{1}{4}$

g $\frac{3}{5} + \frac{1}{10}$

h $\frac{3}{4} - \frac{3}{5}$

i $\frac{5}{6} - \frac{3}{8}$

j $\frac{2}{3} + \frac{1}{2}$

k $\frac{5}{3} - \frac{2}{7}$

l $\frac{3}{8} + \frac{1}{3}$

m $\frac{2}{9} + \frac{1}{12}$

n $\frac{9}{21} + \frac{1}{7}$

o $\frac{27}{50} - \frac{7}{20}$

p $\frac{11}{30} - \frac{7}{45}$

Hint: First express each fraction using the LCD.



Example 19 Adding and subtracting mixed numbers

Evaluate:

a $1\frac{2}{3} + 4\frac{5}{6}$

b $3\frac{2}{5} - 2\frac{3}{4}$

Solution

Explanation

$$\begin{aligned} \text{a } 1\frac{2}{3} + 4\frac{5}{6} &= \frac{5}{3} + \frac{29}{6} \\ &= \frac{10}{6} + \frac{29}{6} \\ &= \frac{39}{6} \\ &= \frac{13}{2} \text{ or } 6\frac{1}{2} \end{aligned}$$

Change each mixed number to an improper fraction.

Remember that the lowest common denominator of 3 and 6 is 6. Change $\frac{5}{3}$ to an equivalent fraction with denominator 6 then add the numerators and simplify.

$$\begin{aligned} \text{b } 3\frac{2}{5} - 2\frac{3}{4} &= \frac{17}{5} - \frac{11}{4} \\ &= \frac{68}{20} - \frac{55}{20} \\ &= \frac{13}{20} \end{aligned}$$

Convert to improper fractions and then express as equivalent fractions with the same denominator.

Subtract the numerators.

Now you try

Evaluate:

a $2\frac{3}{4} + 1\frac{5}{8}$

b $4\frac{1}{3} - 3\frac{4}{5}$

7 Evaluate the following.

a $1\frac{1}{3} + 2\frac{1}{2}$

b $1\frac{1}{3} - \frac{3}{4}$

c $5\frac{1}{2} - 2\frac{7}{10}$

d $2\frac{1}{3} + \frac{1}{4}$

e $4\frac{1}{2} + 2\frac{1}{4}$

f $6\frac{1}{3} - 2\frac{1}{2}$

g $1\frac{3}{8} - 1\frac{1}{4}$

h $2\frac{3}{4} - 1\frac{1}{3}$

i $4\frac{1}{10} - 2\frac{2}{5}$

j $1\frac{7}{12} - \frac{2}{3}$

k $3\frac{1}{5} + 1\frac{1}{2}$

l $2\frac{5}{6} - 1\frac{1}{4}$

Hint: First rewrite using improper fractions.



Problem-solving and reasoning

8–10

9–12

- 8 To remove impurities a mining company filters $3\frac{1}{2}$ tonnes of raw material. If $2\frac{5}{8}$ tonnes are removed, what quantity of material remains?



- 9 When a certain raw material is processed it produces $3\frac{1}{7}$ tonnes of mineral and $2\frac{3}{8}$ tonnes of waste. How many tonnes of raw material were processed?
- 10 The ingredients in a punch recipe were: $2\frac{1}{4}$ L of apple juice, $1\frac{1}{2}$ L of guava juice and $1\frac{1}{5}$ L of lemonade.
- How much punch is produced?
 - If a cup holds 150 mL, how many cups can this punch serve?



- 11 Clarissa owns $\frac{3}{10}$ of a company, Sally owns another $\frac{1}{4}$ of the company and Keith owns $\frac{2}{5}$ of it. The bank owns the rest. How much of the company does the bank own?
- 12 Here is an example involving the subtraction of fractions where improper fractions are not used.
- $$2\frac{1}{2} - 1\frac{1}{3} = 2\frac{3}{6} - 1\frac{2}{6}$$
- $$= 1\frac{1}{6}$$

Try this technique on the following problem and explain the difficulty that you find.

$$2\frac{1}{3} - 1\frac{1}{2}$$



Which fractions do you choose?

—

13

- 13 The six fractions listed below are each used exactly once in part a.

$$\frac{1}{8}, \frac{5}{12}, \frac{1}{2}, \frac{2}{3}, \frac{3}{4}, \frac{5}{6}$$

- a Arrange the six fractions correctly so that each equation produces the required answer. Use each fraction only once.

i $\square + \square = \frac{7}{8}$

ii $\square - \square = \frac{1}{4}$

iii $\square - \square = \frac{1}{3}$

- b Which of the fractions, when added, produce an answer of 2?

1A

1 Find the value of:

a $-15 + 7$

d $12 + (-4)$

b $-10 - 4$

e $-8 + 5 - (-7)$

c $18 - (-7)$

f $-9 - (-6)$

1B

2 Find the value of:

a $-7 \times (-6)$

d $-48 \div (-6)$

b $12 \times (-5)$

e $(-4)^3$

c $-56 \div 7$

f $(-9)^2$

1B

3 Apply the order of operations to find the value of:

a $3 \times (4 - 9) + 6$

b $7 - 3 \times (-4)$

c $(6 - 10) \div (-2) - 9$

1C

4 a Round each of the following to two decimal places.

i 24.187

ii -6.143988

iii 7.595699

b Round each of the following to two significant figures.

i 3.268

ii 237

iii 7932.8

iv 0.0078812

1C



5 Estimate the following using one significant figure rounding of each number. Check how reasonable your answer is with a calculator.

a $242 - 121$

b $93.4 - 9.7 \times 0.0234$

1D

6 Write these fractions as decimals, parts c and d are recurring decimals.

a $\frac{5}{8}$

b $3\frac{8}{25}$

c $\frac{7}{12}$

d $2\frac{7}{11}$

1D

7 Write these decimals as simplified fractions.

a 0.8

b 0.36

c 0.004

d 4.205

1D

8 Arrange these fractions in ascending (smallest to largest) order.

$\frac{11}{24}$, $\frac{3}{8}$, $\frac{5}{12}$

1E

9 Evaluate the following.

a $\frac{3}{8} + \frac{2}{8}$

b $\frac{2}{3} - \frac{4}{7}$

c $2\frac{3}{10} + 1\frac{1}{4}$

d $4\frac{1}{5} - 2\frac{3}{4}$

1E

10 A recipe requires $\frac{3}{4}$ cup of sugar, $2\frac{1}{3}$ cups of flour and $\frac{1}{2}$ cup of cocoa. How many cups of ingredients are needed in total?

1F Multiplying and dividing fractions

CONSOLIDATING

Learning intentions

- To review how to multiply fractions
- To know to cancel any factors between numerators and denominators before multiplying
- To know that 'of' means multiply
- To be able to find the reciprocal of a fraction
- To know how to divide by a fraction by multiplying by its reciprocal
- To know to convert mixed numbers to improper fractions before multiplying or dividing

Key vocabulary: numerator, denominator, highest common factor, reciprocal, proper fraction, improper fraction, mixed number

A series of steps can be followed to make multiplying and dividing fractions easier. This includes cancelling, which reduces the size of the numbers inside the fractions.

Lesson starter: How much is left?

How much is left for Kimberly to eat if:

- Tom eats half the tart
- then Sarah eats half of what's left
- then Zara eats a third of the remaining section?



Key ideas

- To multiply fractions (proper or improper), multiply the numerators together and multiply the denominators together.

- In general:

$$\frac{a}{b} \times \frac{c}{d} = \frac{a \times c}{b \times d}$$

For example:

$$\begin{aligned} \frac{2}{5} \times \frac{3}{7} &= \frac{2 \times 3}{5 \times 7} \\ &= \frac{6}{35} \end{aligned}$$

- To divide a number by a fraction, multiply by its reciprocal.

- In general:

$$\frac{a}{b} \div \frac{c}{d} = \frac{a}{b} \times \frac{d}{c} = \frac{a \times d}{b \times c}$$

For example:

$$\begin{aligned} \frac{2}{3} \div \frac{5}{6} &= \frac{2}{3} \times \frac{6}{5} \\ &= \frac{2}{\cancel{3}^1} \times \frac{\cancel{6}^2}{5} \\ &= \frac{4}{5} \end{aligned}$$

- *Of* means multiply.

For example:

$$\frac{1}{3} \text{ of } 24 = \frac{1}{3} \times 24$$

- Cancel any common factors in the numerator with any common factors in the denominator before multiplying.

$$\begin{aligned} \frac{\cancel{1}^1}{48} \times \frac{\cancel{2}^1}{\cancel{3}^1 \cancel{15}^1} &= \frac{1}{4} \times \frac{1}{3} \\ &= \frac{1}{12} \end{aligned}$$

- To find the **reciprocal** of a fraction, you simply invert it (that is, flip the proper or improper fraction upside down).

- The reciprocal of 2 is $\frac{1}{2}$ since $2 = \frac{2}{1}$.
- The reciprocal of $\frac{3}{4}$ is $\frac{4}{3}$.
- The reciprocal of $1\frac{1}{5}$ (or $\frac{6}{5}$) is $\frac{5}{6}$.

Exercise 1F

Understanding

1-3

3

1 State if the following are true (T) or false (F).

a $\frac{2}{5} \times \frac{1}{3} = \frac{2}{15}$

b $\frac{1}{6}$ of 30 = 6×30

c $\frac{3}{7} \div \frac{2}{5} = \frac{3}{7} \times \frac{5}{2}$

2 Find:

a $\frac{1}{2}$ of 24

b $\frac{1}{3}$ of 12

c $\frac{3}{4}$ of 16

d $\frac{9}{10}$ of 200

3 Find the reciprocal of:

a $\frac{3}{4}$

b $\frac{1}{7}$

c 6

d $1\frac{2}{3}$

Hint: Whole numbers can be written with a denominator of 1.
 $6 = \frac{6}{1}$



Fluency

4-7($\frac{1}{2}$)4-7($\frac{1}{2}$)

Example 20 Multiplying with proper fractions

Evaluate the following.

a $\frac{2}{3} \times \frac{5}{7}$

b $\frac{4}{5} \times \frac{25}{32}$

Solution

Explanation

a $\frac{2}{3} \times \frac{5}{7} = \frac{10}{21}$

No common factors therefore multiply the numerators together and multiply the denominators together.

$$\frac{2}{3} \times \frac{5}{7} = \frac{2 \times 5}{3 \times 7}$$

b $\frac{\overset{4^1}{\cancel{4}_1} \times \frac{\overset{25^5}{\cancel{32}_8}}{\cancel{32}_8}}{\cancel{5}_1} = \frac{1}{1} \times \frac{5}{8}$
 $= \frac{5}{8}$

Cancel the common factors between the numerators and the denominators.

Multiply the numerators and then multiply the denominators.

$$\frac{1 \times 5}{1 \times 8}$$

Now you try

Evaluate the following.

a $\frac{3}{7} \times \frac{4}{5}$

b $\frac{3}{8} \times \frac{20}{27}$

4 Evaluate the following.

a $\frac{3}{5} \times \frac{1}{4}$

b $\frac{2}{3} \times \frac{2}{5}$

c $\frac{3}{4} \times \frac{5}{7}$

d $\frac{1}{2} \times \frac{1}{3}$

e $\frac{1}{4} \times \frac{1}{5}$

f $\frac{1}{9} \times \frac{2}{3}$

g $\frac{5}{8} \times \frac{16}{17}$

h $\frac{1}{2} \times \frac{6}{7}$

i $\frac{2}{3} \times \frac{3}{5}$

j $\frac{8}{9} \times \frac{3}{4}$

k $\frac{4}{5} \times \frac{1}{2}$

l $\frac{5}{6} \times \frac{24}{25}$

m $\frac{6}{7} \times \frac{7}{8}$

n $\frac{7}{9} \times \frac{18}{21}$

o $\frac{8}{21} \times \frac{7}{12}$

p $\frac{5}{14} \times \frac{21}{40}$

Hint: First cancel, if possible.



Example 21 Multiplying with mixed numbers

Evaluate $1\frac{2}{3} \times 2\frac{1}{10}$.

Solution

$$1\frac{2}{3} \times 2\frac{1}{10} = \frac{1\cancel{5}}{3} \times \frac{2\cancel{1}7}{\cancel{10}2}$$

$$= \frac{7}{2} \text{ or } 3\frac{1}{2}$$

Explanation

Rewrite as improper fractions.

Cancel common factors between numerators and denominators and then multiply numerators and denominators.

Now you try

Evaluate $1\frac{4}{5} \times 2\frac{1}{3}$.

5 Evaluate:

a $1\frac{1}{2} \times \frac{1}{3}$

b $1\frac{2}{3} \times \frac{3}{4}$

c $2\frac{1}{3} \times \frac{9}{10}$

d $1\frac{1}{2} \times 1\frac{1}{3}$

e $2\frac{1}{3} \times 1\frac{4}{5}$

f $\frac{3}{4} \times 1\frac{1}{7}$

g $2\frac{1}{2} \times 2\frac{1}{2}$

h $4\frac{1}{2} \times \frac{8}{9}$

i $1\frac{3}{4} \times 1\frac{2}{3}$

j $3\frac{3}{4} \times \frac{8}{5}$



Example 22 Dividing fractions

Evaluate the following.

a $\frac{4}{15} \div \frac{12}{25}$

b $1\frac{17}{18} \div 1\frac{1}{27}$

Solution

$$a \quad \frac{4}{15} \div \frac{12}{25} = \frac{4}{\cancel{3}15} \times \frac{25\cancel{5}}{\cancel{12}3}$$

$$= \frac{5}{9}$$

Explanation

To divide by $\frac{12}{25}$ we multiply by its reciprocal $\frac{25}{12}$.

Cancel common factors between numerators and denominators then multiply fractions.

$$b \quad 1\frac{17}{18} \div 1\frac{1}{27} = \frac{35}{18} \div \frac{28}{27}$$

$$= \frac{\cancel{5}35}{\cancel{2}18} \times \frac{\cancel{27}3}{\cancel{28}4}$$

$$= \frac{15}{8} \text{ or } 1\frac{7}{8}$$

Rewrite mixed numbers as improper fractions.

Multiply by the reciprocal of the second fraction.

The reciprocal of $\frac{28}{27}$ is $\frac{27}{28}$.

Continued on next page

1F

Now you try

Evaluate the following.

a $\frac{5}{12} \div \frac{5}{18}$

b $1\frac{7}{8} \div 1\frac{1}{24}$

6 Evaluate the following (recall that the reciprocal of 8 is $\frac{1}{8}$).

a $\frac{4}{7} \div \frac{3}{5}$

b $\frac{3}{4} \div \frac{2}{3}$

c $\frac{5}{8} \div \frac{7}{9}$

d $\frac{3}{7} \div \frac{4}{9}$

e $\frac{3}{4} \div \frac{9}{16}$

f $\frac{4}{5} \div \frac{8}{15}$

g $\frac{8}{9} \div \frac{4}{27}$

h $\frac{15}{42} \div \frac{20}{49}$

i $15 \div \frac{5}{6}$

j $6 \div \frac{2}{3}$

k $\frac{4}{5} \div 8$

l $\frac{8}{9} \div 6$

Hint: Multiply by the reciprocal of the second fraction.



7 Evaluate the following.

a $14 \div 4\frac{1}{5}$

b $6 \div 1\frac{1}{2}$

c $1\frac{1}{3} \div 8$

d $2\frac{1}{4} \div 1\frac{1}{2}$

e $4\frac{2}{3} \div 5\frac{1}{3}$

f $7\frac{1}{5} \div \frac{4}{15}$

Hint: First change any mixed numbers to improper fractions.



Problem-solving and reasoning

8(½), 9, 10

8(½), 9, 11, 12

8 Find the following amounts.

a $\frac{1}{2}$ of \$20

b $\frac{1}{2}$ of \$7

c $\frac{1}{3}$ of \$18

d $\frac{3}{4}$ of \$24

e $\frac{4}{5}$ of \$8000

f $\frac{9}{10}$ of \$1

Hint: 'Of' means multiply and 20 as a fraction is $\frac{20}{1}$.

9 Evaluate these mixed-operation problems.

a $\frac{2}{3} \times \frac{1}{3} \div \frac{7}{9}$

b $\frac{4}{5} \times \frac{3}{5} \div \frac{9}{10}$

c $\frac{4}{9} \times \frac{6}{25} \div \frac{1}{150}$

10 In a $1\frac{1}{2}$ hour maths exam, $\frac{1}{6}$ of that time is allocated as reading time. How long is the reading time?11 A car's fuel gauge shows that it has $\frac{1}{4}$ of a tank of petrol remaining. The petrol tank holds 64 litres of fuel when full. The car can travel 10 km on 1 litre. How many kilometres can you travel on the amount of petrol that remains in the tank?

- 12 Thomas, Ahn and Oscar agree to equally share the job of cleaning the house after a party. They estimate the job will take $4\frac{1}{2}$ hours to complete. How many minutes of work should they each contribute?



Electronics and reciprocals

—

13



- 13 Reciprocals are used in the study of electronics. On the calculator, the x^{-1} button can be used to find the reciprocal of a number.
- a Use this button to find reciprocals of the following numbers.
- i 2 ii 5 iii 6.2 iv 1.5 v -1
- b If $\frac{1}{6.4} + \frac{1}{7.2} = A$, find the value of $\frac{1}{A}$ (to 2 decimal places).
- c If $\frac{1}{50} + \frac{1}{50} = B$, what is $\frac{1}{B}$?
- d Investigate, using your calculator, the types of numbers for which the reciprocal is bigger than the original number.
- e What positive number is its own reciprocal?
- f Are there any numbers that do not have a reciprocal?



1G Ratios

CONSOLIDATING

Learning intentions

- To understand how ratios are used
- To know how to express a ratio in simplest form using whole numbers with no common factor
- To know that the unitary method involves finding the value of one part
- To be able to use the unitary method to divide a quantity in a given ratio

Key vocabulary: ratio, unitary method, highest common factor

Fractions, ratios and rates are used to compare quantities. A lawn mower, for example, might require $\frac{1}{6}$ of a litre of oil to make a petrol mix of 2 parts oil to 25 parts petrol, which is an oil to petrol ratio of 2 to 25 or 2 : 25.



→ Lesson starter: The lottery win

\$100 000 is to be divided up for three lucky people into a ratio of 2 to 3 to 5 (2 : 3 : 5). Work out how the money is to be divided.

- Clearly write down your method and answer. There may be many different ways to solve this problem.
- Write down and discuss the methods suggested by other students in the class.

Key ideas

- **Ratios** are used to compare quantities with the same units.
 - The ratio of a to b is written $a : b$.
 - Ratios in simplest form use whole numbers that have no common factor.
- The **unitary method** involves finding the value of one part of a total.
 - Once the value of one part is found, then the value of several parts can easily be determined.

Exercise 1G

Understanding

1–3

3

1 State if each of the following ratios is in simplest form (yes or no).

a 4 : 10

b 3 : 7

c 20 : 39

d 48 : 64

2 Draw up a table with the following headings.

Diagram	Ratio of shaded parts to unshaded parts	Ratio of shaded parts to parts in the whole
---------	---	---

Enter information about these diagrams to complete the table.

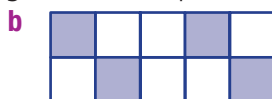
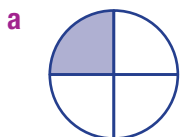

- 3 At a school presentation assembly there were five times as many boys as adults and twice as many girls as boys. Write the ratio of:
- boys to adults
 - boys to girls
 - girls to boys
 - girls to adults
 - boys to the total number of people at the assembly

Hint: Remember that, with a ratio, the order matters.



Fluency

4–8(½)

4–8(½)



Example 23 Simplifying ratios using HCFs

Simplify the ratio 38 : 24.

Solution

Explanation

$$38 : 24 = 19 : 12$$

The HCF of 38 and 24 is 2 so divide both sides by 2.

Now you try

Simplify the ratio 45 : 27.

- 4 Simplify these ratios.

a 6 : 30

b 8 : 20

c 40 : 50

d 2 : 20

e 15 : 18

f 9 : 27

g 18 : 6

h 24 : 36

i 52 : 39

j 144 : 36

k 48 : 96

l 30 : 10

m 2000 : 5600

n 3 : 6 : 12

o 15 : 30 : 10

Hint: Divide by the HCF.



Example 24 Simplifying ratios involving fractions and decimals

Simplify these ratios.

a 0.2 : 0.14

b $2\frac{1}{2} : 1\frac{1}{3}$

Solution

Explanation

$$\begin{aligned} \mathbf{a} \quad 0.2 : 0.14 &= 20 : 14 \\ &= 10 : 7 \end{aligned}$$

Multiply by 100 to remove all the decimal places and simplify.

$$\begin{aligned} \mathbf{b} \quad 2\frac{1}{2} : 1\frac{1}{3} &= \frac{5}{2} : \frac{4}{3} \\ &= \frac{15}{6} : \frac{8}{6} \\ &= 15 : 8 \end{aligned}$$

Write as improper fractions using the same denominator.

Multiply both sides by 6 to write as whole numbers.

Now you try

Simplify these ratios.

a 0.5 : 0.32

b $3\frac{1}{4} : 1\frac{7}{8}$

1G

5 Simplify these ratios.

a $0.1 : 0.2$

d $0.3 : 0.9$

g $8 : 0.2$

b $0.3 : 4.1$

e $0.7 : 3.5$

h $15 : 0.01$

c $0.5 : 3.2$

f $0.4 : 0.12$

i $1.6 : 0.56$

6 Simplify:

a $\frac{1}{4} : \frac{1}{3}$

d $2\frac{1}{4} : 1\frac{2}{5}$

b $\frac{2}{3} : \frac{1}{4}$

e $\frac{3}{8} : 1\frac{3}{4}$

c $1\frac{1}{2} : 3\frac{1}{3}$

f $1\frac{5}{6} : 3\frac{1}{4}$

Hint: A simplified ratio must include only whole numbers (with no common factors).



Example 25 Simplifying ratios involving units

Simplify the ratio of 560 metres to 2 kilometres.

Solution

$$\begin{aligned} 560 \text{ m} : 2 \text{ km} \\ = 560 \text{ m} : 2000 \text{ m} \\ = 560 : 2000 \\ = 7 : 25 \end{aligned}$$

Explanation

Write using ratio notation.
Convert the units so that both are the same:
 $2 \text{ km} = 2000 \text{ m}$
Cancel the units and divide both numbers by their HCF. HCF of 560 and 2000 is 80

Now you try

Simplify the ratio of 35 cents to \$2.

7 Write each of the following as a ratio in simplest form.

a $80\text{c} : \$8$

c $80 \text{ cm} : 1.2 \text{ m}$

e $2.5 \text{ kg} : 400 \text{ g}$

g $45 \text{ min} : 3 \text{ hours}$

i $40 \text{ cm} : 2 \text{ m} : 50 \text{ cm}$

k $2.5 \text{ hours} : 1.5 \text{ days}$

b $90\text{c} : \$4.50$

d $0.7 \text{ kg} : 800 \text{ g}$

f $30 \text{ min} : 2 \text{ hours}$

h $4 \text{ hours} : 50 \text{ min}$

j $80 \text{ cm} : 600 \text{ mm} : 2 \text{ m}$

l $0.09 \text{ km} : 300 \text{ m} : 1.2 \text{ km}$

Hint: Convert to the same units first.



Example 26 Dividing into a given ratio

\$300 is to be divided into the ratio 2 : 3.
Find the value of the larger portion using the unitary method.

Solution

$$\begin{aligned} \text{Total number of parts is } 2 + 3 = 5 \\ 5 \text{ parts} = \$300 \end{aligned}$$

$$\begin{aligned} 1 \text{ part} &= \frac{1}{5} \text{ of } \$300 \\ &= \$60 \end{aligned}$$

$$\begin{aligned} \text{Larger portion} &= 3 \times \$60 \\ &= \$180 \end{aligned}$$

Explanation

Use the ratio 2 : 3 to get the total number of parts.

Calculate the value of each part. ($\$300 \div 5$)

Calculate the value of 3 parts.

Now you try

\$600 is to be divided into the ratio 5 : 7.
Find the value of the larger portion using the unitary method.

8 Use the unitary method to divide:

- a** \$500 in the ratio of 1 : 4 **b** \$36 in the ratio of 4 : 5
c 88 kg in the ratio of 3 : 8 **d** \$96 in the ratio of 7 : 5
e \$500 in the ratio of 2 : 3 **f** 2000 g in the ratio of 3 : 5
g \$100 in the ratio of 7 : 3 **h** \$600 in the ratio of 1 : 1
i \$70 in the ratio of 2 : 7 : 1 **j** 420 g in the ratio of 8 : 2

Hint: First find the value of one part.



Problem-solving and reasoning

9–11

10–13

- 9 420 g of flour is to be divided into a ratio of 7 : 3 for two different recipes. Find the smaller amount.
- 10 Kirsty manages a restaurant. Each day she buys watermelons and mangoes in the ratio of 3 : 2. How many watermelons did she buy if, on one day, the total number of watermelons and mangoes was 200?
- 11 If a prize of \$6000 was divided among Georgia, Leanne and Maya in the ratio of 5 : 2 : 3, how much did each girl get?



- 12 The dilution ratio for a particular chemical with water is 2 : 3 (chemical to water). If you have 72 litres of chemical, how much water is needed to dilute the chemical?

Hint: If 72 litres is two parts, what is one part?



- 13 Amy, Belinda, Candice and Diane invested money in the ratio of 2 : 3 : 1 : 4 in a publishing company. If the profit was shared according to their investment, and Amy's profit was \$2400, find the profit each investor made.



Mixing drinks

—

14

- 14 Four jugs of cordial have a cordial to water ratio as shown and a given total volume.

Jug	Cordial to water ratio	Total volume
1	1 : 5	600 mL
2	2 : 7	900 mL
3	3 : 5	400 mL
4	2 : 9	330 mL

- a** How much cordial is in:
i Jug 1? **ii** Jug 2?
b How much water is in:
i Jug 3? **ii** Jug 4?
c If Jug 1 and 2 were mixed together to give 1500 mL of drink:
i how much cordial is in the drink?
ii find the ratio of cordial to water in the drink.
d Find the ratio of cordial to water if the following jugs are mixed.
i Jug 1 and 3 **ii** Jug 2 and 3
iii Jug 2 and 4 **iv** Jug 3 and 4
e Which combination of two jugs gives the strongest cordial to water ratio?



1H Rates and direct proportion

Learning intentions

- To understand what a rate represents and how it is expressed in simplest form
- To know and be able to use the speed = distance \div time relationship to determine an unknown
- To be able to use rates to determine best buys
- To understand what it means for two quantities to be in direct proportion
- To be able to use a direct proportion relationship to solve problems

Key vocabulary: rate, direct proportion

It is often necessary to compare two quantities with different units. When this occurs it is called a rate.

Rates are used to describe speed (m/s, km/h), pay, lap times in formula one racing, and even the prices at the supermarket. Using rates is important in our everyday lives.



→ Lesson starter: Fastest animals on Earth

In pairs, arrange these animals from fastest to slowest. Then see if you can write their speeds in metres per second (m/s).



Zebra 64.37 km/h



Ostrich 70 km/h



Giraffe 52 km/h



African bush elephant 40.7 km/h



Lion 80 km/h



Cheetah 120 km/h



Dog 72.4 km/h



Galapagos tortoise 0.32 km/h



Kangaroo 70.01 km/h



Wildebeest 64.05 km/h



Hyena 65 km/h



Fox 32.03 km/h

Key ideas

- A **rate** compares related quantities with different units.
 - The rate is usually written with one quantity compared to a single unit of the other quantity. For example: 50 km per 1 hour or 50 km/h
- Rates can be used to determine best buys when purchasing products.
- Speed (S) = distance (D) \div time (T)
For example:
80 km in 2 hours = 40 km/h

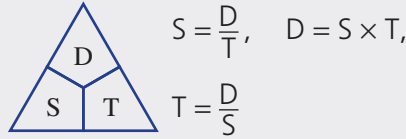

- Two quantities are in **direct proportion** when they increase or decrease in the same ratio. For example:
If the cost of petrol doubles from \$1.40 per litre to \$2.80 per litre, then the cost of filling your 60-litre petrol tank doubles from \$84 to \$168.

Exercise 1H

Understanding

1–4

3, 4

- Write the following as simple rates using the / symbol.
 - Tom travelled 60 km in 1 hour
 - \$84 in 1 hour
 - 600 km in 10 hours
- Find the cost of 1 kg if:
 - 2 kg costs \$8
 - 5 kg costs \$15
 - 4 kg costs \$10
- Determine the speed of the following trips
 - 100 m in 10 seconds
 - 120 km in 2 hours
 - 42 km in 3 hours
- Callum's daily wage is directly proportional to the number of hours he works. If he works for 2 hours, he earns \$42. How much does he earn if the number of hours worked:
 - doubles?
 - halves?
 - triples ($\times 3$)?

Hint: Compare to 1 hour in part c.



Hint: Use units m/s or km/h.



Fluency

5–6(1/2), 7, 8–9(1/2)

5–6(1/2), 8–9(1/2)



Example 27 Simplifying rates

Write these rates in simplest form.

- 120 km every 3 hours
- 5000 revolutions in $2\frac{1}{2}$ minutes

Solution

$$\begin{aligned} \text{a } 120 \text{ km per 3 hours} &= \frac{120}{3} \text{ km/h} \\ &= 40 \text{ km/h} \end{aligned}$$

Explanation

Divide by 3 to write the rate compared to 1 hour.

Continued on next page

1H

$$\begin{aligned}
 \text{b } & 5000 \text{ revolutions per } 2\frac{1}{2} \text{ minutes} \\
 & = 10\,000 \text{ revolutions per } 5 \text{ minutes} \\
 & = \frac{10\,000}{5} \text{ revs/min} \\
 & = 2000 \text{ revs/min}
 \end{aligned}$$

First multiply by 2 to remove the fraction.

Then divide by 5 to write the rate using 1 minute.

Now you try

Write these rates in simplest form.

a \$150 in 5 hours

b 1800 revolutions in $1\frac{1}{2}$ minutes

5 Write these as rates in their simplest form.

a \$84 in 3 hours

c 12 kg every 2 minutes

e 64 runs in 16 overs

g 76 cm in 4 years

i 207 heart beats in $2\frac{1}{4}$ minutes

b \$200 in 4 hours

d \$3.50 for $\frac{1}{2}$ kg

f 623 points in 7 games

h 56 metres in 4 seconds

j 180 mL in 22.5 seconds

Hint: Work out each per one unit.

**Example 28 Determining distance, speed and time**

A family took 3 hours to complete the 210 km from their home to their holiday house.

a Find their average speed for the trip.

b If they increased their average speed to 90 km/h, how many hours and minutes would the trip have taken?

Solution

$$\begin{aligned}
 \text{a } & \text{Average speed} = \text{distance} \div \text{time} \\
 & = 210 \text{ km} \div 3 \text{ hours} \\
 & = 70 \text{ km/h}
 \end{aligned}$$

Explanation

Use the DST triangle and cover the S to provide the formula for finding speed: $S = \frac{D}{T}$ or $D \div T$

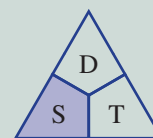

Substitute in your values and calculate the speed.

Remember to put units in your answer.

$$\begin{aligned}
 \text{b } & \text{Time} = \text{distance} \div \text{speed} \\
 & = 210 \text{ km} \div 90 \text{ km/h} \\
 & = 2\frac{1}{3} \text{ hours} \\
 & = 2 \text{ hours } 20 \text{ minutes}
 \end{aligned}$$

Use the DST triangle and cover the T to find the formula for time:

$$T = \frac{D}{S} \text{ or } D \div S$$

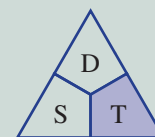

Substitute in your values and find the time:

$$\frac{1}{3} \text{ hour} = \frac{1}{3} \times 60 \text{ min} = 20 \text{ minutes}$$

Now you try

A rally driver took 5 hours to complete a 300 km course.

- a Find the average speed for the rally.
- b If the average speed was increased to 72 km/h, how many hours and minutes would the course have taken?

- 6 Find the average speed (km/h) of:
- a a car travelling 140 km in 2 hours
 - b a bike travelling 60 km in 4 hours
 - c a walker travelling 12 km in 3 hours
 - d a horse galloping 2.7 km in 3 minutes ($\frac{1}{20}$ hour)
 - e a truck travelling 760 km in 9.5 hours



- 7 Rick drives the 1040 km from Sydney to Melbourne to watch the Sydney Swans play the Western Bulldogs in the AFL. He averaged 80 km/h.
- a How many hours did the trip take?
 - b How many hours and minutes would the trip take if the average speed was reduced to 64 km/h?

**Example 29 Finding best buys**

Which is better value?

5 kg of potatoes for \$3.80 or 3 kg for \$2.20

Solution

Price per kg.

5 kg bag.

$$1 \text{ kg costs } \$3.80 \div 5 = \$0.76$$

3 kg bag.

$$1 \text{ kg costs } \$2.20 \div 3 = \$0.73$$

\therefore the 3 kg bag is cheaper

Explanation

Divide each price by the number of kilograms to find the price per kilogram.

Then compare. Choose the cheapest.

Now you try

Which is better value?

2 L of chocolate ice cream for \$4.50 or 3 L of the same ice cream for \$6.45.



- 8 Determine the best buy in each of the following.
- a 2 kg of washing powder for \$11.70 or 3 kg for \$16.20
 - b 1.5 kg of red delicious apples for \$4.80 or 2.2 kg of royal gala apples for \$7.92
 - c 2.4 litres of orange juice for \$4.20 or 3 litres of orange juice for \$5.40
 - d 0.7 GB of internet usage for \$14 or 1.5 GB for \$30.90 with different service providers



1H

Example 30 Using direct proportion



The amount of fertiliser needed is directly proportional to the area of land being covered. A company claims that one 8 kg bag of its product covers 10 m^2 . How many kilograms would be needed to cover 25 m^2 ?

Solution

8 kg per 10 m^2
 $= 0.8 \text{ kg/m}^2$
 0.8×25
 $= 20 \text{ kg}$ are needed for 25 m^2

Explanation

Write the rate: $8 \text{ kg}/10 \text{ m}^2$
 Divide by 10 to simplify the rate to kg per m^2 .
 Multiply by 25 to find the kilograms needed for 25 m^2 .

Now you try

The amount of paint needed is directly proportional to the wall area being painted. A tin of 4 L paint covers 50 m^2 . How many litres would be needed to cover 20 m^2 ?

- 9 Consider the following.
- The number of words Shute can type is directly proportional to the time he works. If Shute types 65 words a minute, how many words can he type in:
 - 2 minutes?
 - 5 minutes?
 - 1 hour?
 - The grams of copper needed by a jeweller to make up his alloy is directly proportional to the grams of gold he uses. If he uses 3 grams of copper per 22 grams of gold, find the gold needed for:
 - 6 grams of copper
 - 30 grams of copper
 - Sally and Tom both pay the same proportion of their income in tax. When Sally earns \$25 000 she pays \$5000 in tax. How much tax does Tom pay if he earns four times what Sally does?
 - A carpet cleaner charges \$80 per 20 m^2 of carpet cleaned. How much would it cost to clean 4 rooms with a total of 45 m^2 of carpet?

Problem-solving and reasoning

10–12

11, 13, 14

- 10 Hamish rides his bike at an average speed of 22 km/h. How far does he ride in:
- $2\frac{1}{2}$ hours?
 - $\frac{3}{4}$ hours?
 - 15 minutes?
- 11 Find the cost of 100 g of each product below then decide which is the best buy.
- 300 g of coffee A at \$10.80 or 220 g of coffee B at \$8.58.
 - 600 g of pasta A for \$7.50 or 250 g of pasta B for \$2.35
 - 1.2 kg of cereal A for \$4.44 or 825 g of cereal B for \$3.30
- 12 A shearer sheared 80 sheep in 2 hours.
- Express this as a rate.
 - If the shearer is able to continue at this rate for $5\frac{1}{2}$ hours, how many sheep can be sheared?
 - How long would it take, at this rate, to shear all 1000 sheep on the property?



-  **13** Light travels at approximately 300 000 km/s.
- Express this speed as km/h.
 - How far does light travel in 2 minutes?
 - How long does light from the Sun take to travel the 149 million kilometres to Earth?



- 14** Decide whether each of the following situations could reasonably be described as an example of direct proportion.
- An increase in the cost of petrol to the amount paid
 - An increase in speed to the time taken
 - The increase in food eaten to weight gained
 - The increase in a toddler's height to their years of age
 - The increase in heart rate to the time spent exercising



Practical rates, direct proportion

—

15

- 15** A cyclist's progress over a journey of 160 km is recorded. The ratio of time (in hours) to distance (in kilometres) is 1 : 20.

- a** Copy and complete the table showing the progress of the cyclist.

Time in hours	0	1	2	3	4	5	6	7	8
Distance in km	0	20							

- What is the cyclist's average speed?
- Draw a set of axes like the ones shown and record the information from the table onto the axes.
- What conclusions can you make about the shape of the graph? Why is this the case?
- If the cyclist doubles their speed, on the same set of axes plot a graph that shows the journey for this new speed.

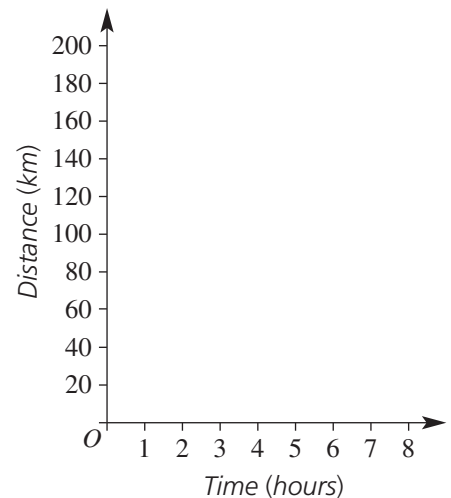



Maths@Work: Cooks and chefs

Being a professional cook or chef is a physically demanding job. Long hours in hot kitchens and being on your feet all day are challenging. Most chefs have a passion for food and flavours and are seen as creative people who create not just a meal but a masterpiece on a plate.

Chefs need to have good communication skills, a practical sense of measurement and excellent number skills. Their job involves ordering stock, understanding cooking temperatures and adapting recipes using ratios and direct proportion.



- 1 A recipe for a classic Pavlova uses 6 egg whites and 270 grams ($1\frac{1}{4}$ cups) of superfine sugar or caster sugar and serves 8. (A Pavlova also contains cornflour and white vinegar.)
 - a What is the simplified ratio of egg whites to servings?
 - b How many egg whites are needed for a Pavlova serving 12 people?
 - c How many whole egg whites are needed for a Pavlova serving 6 people?
 - d How many servings are in a Pavlova using 15 egg whites?
 - e How many grams of sugar are equivalent to 1 cup?
 - f How many grams of sugar are needed per egg white for this Pavlova recipe?

- 2 A café style banana bread recipe indicates that it would make 3 large loaves. The recipe is as follows:
 - 9 cups of plain flour
 - $4\frac{1}{2}$ cups sugar
 - 3 teaspoons of bicarb of soda
 - 1125 grams of melted butter
 - 9 eggs
 - 10 mashed bananas
 - a If each loaf can be cut into 18 single slices, how many loaves need to be baked per day for 50 single slice serves at a café?
 - b How many cartons of a dozen eggs are needed for a week where the cook makes this recipe 8 times?
 - c If 1 egg weighs 75 grams, what is the simplified ratio of eggs to butter in this recipe?
 - d If 1 cup of plain flour is equivalent to 150 grams of flour, how many grams of flour is needed for this recipe?
 - e What is the simplified ratio of flour to melted butter for this recipe?
 - f If only one loaf is to be made, write down the amounts of ingredients required.



3 Many chefs start their careers mastering the basics such as mayonnaise.

The recipe for 1 cup of classic mayonnaise is:

- 2 egg yolks
- 2 teaspoons of lemon juice
- 1 teaspoon of mustard
- $\frac{1}{2}$ teaspoon of salt
- pinch of pepper
- 250 mL of olive oil



a What is the simplified ratio of:

- i lemon juice to mustard?
- ii lemon juice to olive oil (1 teaspoon = 5 mL)?
- iii mustard to salt?

b If a litre is the same as 4 cups, how many eggs are needed for 1 L of mayonnaise?

c If one lemon yielded 25 mL of fresh juice, how many cups of mayonnaise can be made using all of the juice in this one lemon?

4 Scaling a recipe means that the ingredient quantities are each multiplied by a conversion factor so that the recipe makes more or fewer serves. If a cake recipe makes 12 cupcakes, what conversion factor is required to scale up the recipe quantities to make 42 cupcakes?

Using technology

5 Set up an Excel spreadsheet as shown below for scaling cookie recipe quantities. Enter formulas in the shaded cells.

Hint: Format all formula cells to 'number'/one decimal place. Use \$ signs to fix (i.e. anchor) a cell reference, e.g. \$C\$4.



	A	B	C	D
1	Bella's Bakery			
2	Chocloate chip cookies recipe			
3	Recipe number of cookies	Desired number of cookies	Conversion factor	
4	24	60		
5	Ingredient	Recipe quantities	Unit	Scaled quantities
6	Eggs	1	egg	
7	Macadamia nut oil	60	mL	
8	Apple sauce	2	teaspoon	
9	Brown sugar	160	g	
10	Vanilla extract	1	teaspoon	
11	Plain flour	1	cup	
12	Baking powder	1	teaspoon	
13	Rolled oats	1	cup	
14	Dark chocolate	100	g	

a For a recipe to make 60 cookies, state the quantities of the following ingredients:

- i oil
- ii flour
- iii chocolate

b Bella has a school tuckshop order for 32 bags with 3 cookies in each. State the quantities of the following ingredients that Bella will need:

- i eggs
- ii apple sauce
- iii sugar



Painting makeover

Archer and Emily are mixing their own paint to form a special colour for their lounge room and bedroom makeover. They have tested the following ratios and feel that these two options, A and B, suit their tastes.

	White	Yellow	Red	Blue
Colour Ratio A	18	2	1	3
Colour Ratio B	14	3	2	1

Archer and Emily want to know the amount and cost of paint required to cover the walls and ceiling of the lounge room and bedroom using either ratio A mix or ratio B mix.

The white paint costs \$8 per litre and the colours all cost \$24 per litre.
 The paint covers 10 m^2 per litre.
 The lounge room is 6 m long, 5 m wide and 2.5 m high.
 The bedroom is 5 m long, 4 m wide and 2.5 m high.

Present a report for the following tasks and ensure that you show clear mathematical workings, explanations and diagrams where appropriate.

Preliminary task

- a** Using the table above, copy and complete the colour ratios for:
- i** Colour Ratio A, $W : Y : R : B = \square : \square : \square : \square$
- ii** Colour Ratio B, $W : Y : R : B = \square : \square : \square : \square$
- b** What fraction of:
- i** white paint is in ratio A? **ii** blue paint is in ratio A?
- iii** white paint is in ratio B? **iv** red paint is in ratio B?
- c** If 36 L of paint is required in total, find the volume of the following amounts giving each answer as a mixed number.
- i** white paint in ratio A **ii** blue paint in ratio A
- iii** white paint in ratio B **iv** red paint in ratio B

Modelling task

The problem is to compare the cost of painting the lounge room and bedroom using the colour mixes A and B.

- a** Write down all the relevant information that will help solve this problem.
- b** For the lounge room and bedroom
- i** Draw a labelled diagram of each rectangular ceiling and each room's 4 rectangular walls.
- ii** For each room, calculate the total area of the walls and ceiling in m^2 .
- iii** If 2 coats of paint are applied, calculate the total area to be painted.
- iv** Determine the total volume of paint needed given that each litre covers 10 m^2 .

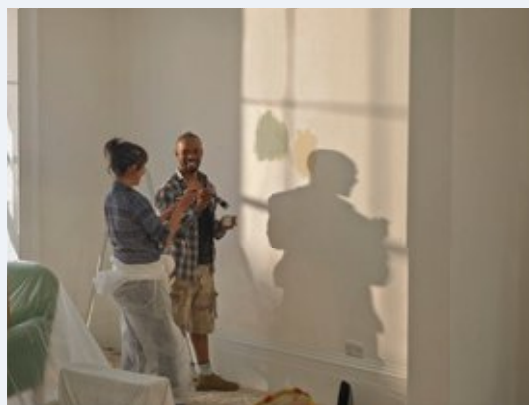

- c** For Colour ratio A, determine:
- i** The fraction that is white paint and the fraction that is coloured paint.
 - ii** The volume of white paint needed.
 - iii** The cost of white paint at \$8 per Litre.
 - iv** The volume of coloured paint needed.
 - v** The cost of coloured paint at \$24 per Litre.
- d** For Colour ratio B, determine:
- i** The fraction that is white paint and the fraction that is coloured paint.
 - ii** The volume of white paint needed.
 - iii** The cost of white paint at \$8 per Litre.
 - iv** The volume of coloured paint needed.
 - v** The cost of coloured paint at \$24 per Litre.

Solve

- e** Determine the total cost of the paint for colour ratio A and for colour ratio B.
- f** Which colour ratio will be the cheaper option and by how much?
- g** Compare the percentages of white and coloured paint in ratios A and B.
- h** Explain why one ratio produces a more expensive paint.

Evaluate
and
verify

- i** Summarise your results and describe any key findings.

Communicate

Extension questions

Emily paints the bedroom at the same time as Archer paints the lounge room. Emily paints at a rate of 13 m^2 per hour and Archer paints at a rate of 17 m^2 per hour.

- a** How long does it take for one coat of paint to be applied to each room?
- b** If there is a 3 hour gap between coats, find the total time needed for this painting makeover.



- 1 Can you arrange the first nine counting numbers using signs (+, −, ×, ÷) and brackets to give an answer of 100?
- 2 In how many ways can four girls and two boys be seated in a row if the two boys are to sit at the ends?
- 3 Complete the number cross below.

1.	2.	3.	
4.		5.	6.
7.	8.	9.	
10.			

Clues



Across

2. The sum of 100, 150 and 3
4. The product of 5 and the first prime number after 6
5. Reverse the digits of the product of 13 and 5
7. One less than the square of 10
9. Half of 6 times 8
10. 2 to the power of 7

Down

1. A palindromic number
2. $5 \times 10 - 5 \times 5$
3. A multiple of 11
6. 639 written correct to two significant figures
8. The next even integer after 90
9. A multiple of 7

- 4 a Perfect numbers are positive integers which are equal to the sum of all their factors, excluding the number itself.
 - i Show that 6 is a perfect number.
 - ii There is one perfect number between 20 and 30. Find the number.
 - iii The next perfect number is 496. Show that 496 is a perfect number.
- b Triangular numbers are the number of dots required to form triangles as shown in this table.
 - i Complete this table.

Number of rows	1	2	3	4	5	6
Diagram						
Number of dots (triangular number)	1	3				

- ii Find the 7th and 8th triangular numbers.
- c Fibonacci numbers are a sequence of numbers where each number is the sum of the two preceding numbers. The first two numbers in the sequence are 0 and 1.
 - i Write down the first 10 Fibonacci numbers.
 - ii If the Fibonacci numbers were to be extended in the negative direction, what would the first four negative Fibonacci numbers be?

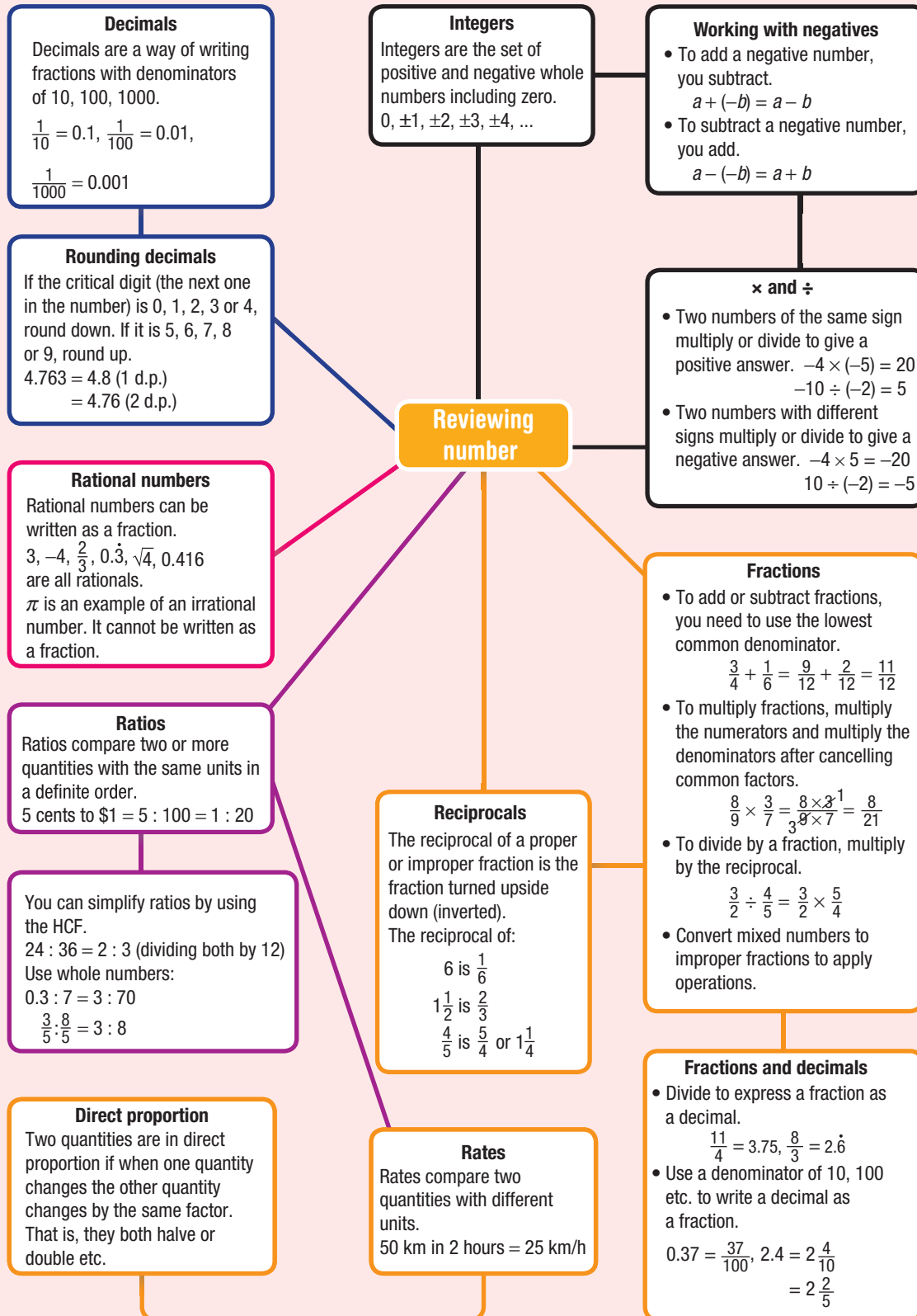

Chapter checklist

A version of this checklist that you can print out and complete can be downloaded from your Interactive Textbook.

		✓
1A	<p>1 I can add and subtract integers. e.g. Find a $-15 + 5$ b $-4 - 6$</p>	
1A	<p>2 I can add a negative integer. e.g. Find $4 + (-9)$</p>	
1A	<p>3 I can subtract a negative integer. e.g. Find $3 - (-7)$</p>	
1B	<p>4 I can multiply and divide with negatives. e.g. Find the value of a $-7 \times (-4)$ b $48 \div (-6)$</p>	
1B	<p>5 I can find squares and cubes of negative numbers. e.g. Find the value of a $(-4)^2$ b $(-5)^3$</p>	
1B	<p>6 I can apply order of operations. e.g. Find the value of $3 \times (-4 + 2) - 5$</p>	
1C	<p>7 I can round to a required number of decimal places. e.g. Round each of these to two decimal places: a 32.2389 b 3.712 c 1.4954</p>	
1C	<p>8 I can round to a number of significant figures. e.g. Round each of these numbers to two significant figures: a 7842 b 0.0375</p>	
1C	<p>9 I can estimate using significant figures. e.g. Estimate the answer to $1067 - 506 \times 0.052$ by rounding each number in the problem to one significant figure. Use your calculator to check how reasonable your answer is.</p>	
1D	<p>10 I can identify rational numbers. e.g. Choose the rational numbers in the following list: $\sqrt{10}, \pi, 1.4, \sqrt{36}, -\frac{3}{5}$</p>	
1D	<p>11 I can convert between mixed numbers and improper fractions. e.g. Express a $\frac{18}{5}$ as a mixed number b $2\frac{3}{7}$ as an improper fraction</p>	



Chapter checklist

1D	<p>12 I can write fractions as decimals, including recurring decimals. e.g. Write</p> <p>a $2\frac{7}{8}$ as a decimal b $\frac{4}{11}$ as a recurring decimal</p>	✓
1D	<p>13 I can write decimals as fractions. e.g. Write these decimals as fractions:</p> <p>a 0.36 b 2.215</p>	
1D	<p>14 I can compare fractions. e.g. Decide which is the larger fraction of the following: $\frac{7}{9}$ or $\frac{11}{15}$</p>	
1E	<p>15 I can add and subtract fractions with the same denominator. e.g. Find</p> <p>a $\frac{8}{17} - \frac{3}{17}$ b $2\frac{1}{8} + \frac{5}{8}$</p>	
1E	<p>16 I can add and subtract fractions with different denominators. e.g. Evaluate $\frac{5}{6} + \frac{3}{5}$</p>	
1E	<p>17 I can add and subtract mixed numbers. e.g. Evaluate:</p> <p>a $2\frac{3}{4} + 1\frac{5}{6}$ b $2\frac{1}{3} - 1\frac{3}{7}$</p>	
1F	<p>18 I can multiply proper fractions. e.g. Evaluate the following:</p> <p>a $\frac{5}{6} \times \frac{1}{4}$ b $\frac{6}{7} \times \frac{14}{27}$</p>	
1F	<p>19 I can divide proper fractions. e.g. Evaluate $\frac{5}{8} \div \frac{15}{28}$</p>	
1F	<p>20 I can multiply and divide with mixed numbers. e.g. Evaluate $4\frac{4}{7} \div 2\frac{2}{3}$</p>	
1G	<p>21 I can simplify ratios. e.g. Simplify these ratios:</p> <p>a 40 : 32 b 0.3 : 0.21 c $\frac{5}{8} : \frac{9}{20}$</p>	
1G	<p>22 I can simplify ratios by converting to common units. e.g. Simplify the ratio of 80 cm to 5 metres</p>	
1G	<p>23 I can divide into a given ratio using the unitary method. e.g. \$480 is to be divided into the ratio 3 : 5. Find the value of the smaller portion using the unitary method.</p>	



Chapter checklist

1H

24 I can simplify a rate.

e.g. Write these rates in simplest form

a 120 L in 2 hours b 108 strokes in $1\frac{1}{2}$ minutes

1H

25 I can determine distance, speed and time.

e.g. A driver took 3 hours to complete a 180 km trip. What was their average speed and what was the time taken, in hours and minutes, on the return trip if the average speed was 75 km/h?

1H

26 I can determine a best buy.

e.g. Which is better value? 4 L of paint for \$84 or 7 L of the same paint for \$126?

1H

27 I can work with direct proportion.e.g. A gardener charges \$15 per 12 m^2 of grass mown. How much would it cost to mow 32 m^2 of lawn?

Short-answer questions

- 1A/1B** 1 Evaluate the following.
a $-4 - (-12)$ **b** $18 - 9 \times 7$ **c** $-90 \times (-3)$
d $(-4)^3$ **e** $-15 \div 5 \times (-2)$ **f** $(10 - 12) \times (7 - 11)$
- 1C** 2 Round these numbers to three significant figures.
a 21.483 **b** 29 130 **c** 0.15271 **d** 0.002414
- 1C** 3 Round to two decimal places:
a 14.97683 **b** 0.7149871498... **c** 1.999
- 1D** 4 Write these fractions as decimals.
a $2\frac{1}{8}$ **b** $\frac{5}{6}$ **c** $\frac{13}{7}$
- 1D** 5 Write these decimals as fractions.
a 0.75 **b** 1.6 **c** 2.55
- 1F** 6 State the reciprocal of:
a $\frac{3}{4}$ **b** $\frac{1}{5}$ **c** 8 **d** $1\frac{2}{7}$
- 1E/1F** 7 Simplify the following.
a $\frac{5}{6} - \frac{1}{3}$ **b** $1\frac{1}{2} + \frac{2}{3}$ **c** $\frac{13}{8} - \frac{4}{3}$
d $3\frac{1}{2} \times \frac{4}{7}$ **e** $5 \div \frac{4}{3}$ **f** $3\frac{3}{4} \div 1\frac{2}{5}$
- 1G** 8 Simplify these ratios.
a 30 : 12 **b** 1.6 : 0.9 **c** $7\frac{1}{2} : 1\frac{2}{5}$
- 1G** 9 Divide 80 into the given ratio.
a 5 : 3 **b** 5 : 11 **c** 1 : 2 : 5
- 1H** 10 Dry dog food can be bought from store A for \$18 for 8 kg or from store B for \$14.19 for 5.5 kg.
 **a** Determine the cost per kilogram at each store and state which is the best buy.
b Determine to the nearest whole number how many grams of each brand you get per dollar.
- 1G** 11 Share \$660 in the ratio of 2 : 3 : 5.
- 1H** 12 Complete these rates.
a \$96 in 3 hours = \$_____/h
b 14 g in 2 minutes = _____g/min
c 32 m in 10 seconds = _____m/min
d \$7.40 in 30 minutes = \$_____/h
e 660 runs in 8 matches = _____runs/match



- 1G** **14** Tom and Claire share their lottery win in the ratio of 3 : 2. If Tom got \$9000, how much did Claire get?
- 1H** **15** In an electrical wire the resistance is directly proportional to the length of the wire. A length of 6 m has a resistance of 5 ohms. What is the length if the resistance is measured to be 30 ohms?
- 1H** **16** If a rectangle's perimeter is directly proportional to its sides, what is the effect on the perimeter of doubling the rectangle's length and width?

Multiple-choice questions

- 1D** **1** $\frac{2}{7}$ written as a decimal is:
- A** 0.29 **B** 0.286 **C** 0.285
D 0.285714 **E** 0.285714
- 1C** **2** 3.0456 written to three significant figures is:
- A** 3.04 **B** 3.05 **C** 3.045
D 3.046 **E** 3.45
- 1D** **3** 2.25 written as a fraction in simplest form is:
- A** $2\frac{1}{2}$ **B** $\frac{5}{4}$ **C** $\frac{9}{4}$
D $9\frac{1}{4}$ **E** $\frac{225}{100}$
- 1E** **4** $1\frac{1}{2} - \frac{5}{6}$ is equal to:
- A** $\frac{2}{3}$ **B** $\frac{5}{6}$ **C** $-\frac{1}{2}$
D $\frac{2}{6}$ **E** $\frac{1}{2}$
- 1F** **5** $\frac{2}{7} \times \frac{3}{4}$ is equivalent to:
- A** $\frac{8}{11}$ **B** $\frac{3}{7}$ **C** $\frac{5}{11}$
D $\frac{8}{12}$ **E** $\frac{3}{14}$
- 1F** **6** $\frac{3}{4} \div \frac{5}{6}$ is equivalent to:
- A** $\frac{5}{8}$ **B** 1 **C** 21
D $\frac{4}{5}$ **E** $\frac{9}{10}$
- 1G** **7** Simplifying the ratio 50 cm : 4 m gives:
- A** 50 : 4 **B** 8 : 1 **C** 25 : 2
D 1 : 8 **E** 5 : 40

1D 8 0.28 as a fraction in its simplest form is:

A 0.28

B $\frac{28}{100}$

C $\frac{0.28}{100}$

D $\frac{2.8}{100}$

E $\frac{7}{25}$

1G 9 \$2.50 divided in the ratio of 4 : 1 is:

A 50 : 200

B 50c

C \$2 : 50c

D \$200

E \$2

1G 10 A childcare centre requires the ratio of carers to children to be 1 : 5. How many carers are needed for 30 children?

A 5

B 6

C 150

D 30

E 36

1H 11 Michael earns \$460 in 25 hours. His hourly rate of pay is:

A \$11500/h

B \$0.05/h

C \$18.40/h

D \$18.40/day

E \$5/h

1H 12 36 km in 40 minutes is the same as:

A 40 km/h

B 36 km/h

C 54 km/h

D 90 km/h

E 56 km/h

1G 13 To mix a particular shade of pink, red paint is mixed in direct proportion to white paint. The ratio is 8 to 3. If 20 cans of red paint are used, how many cans of white paint will be needed to mix the correct shade of pink?

A 15

B 7.5

C 7

D 8

E 24

Extended-response questions

- 1 A class of 28 students has a ratio of boys to girls that is 3 : 4.
- How many boys are in the class?
 - Two boys leave and are replaced by two girls. How many boys and girls are now in the class?
 - What is the new ratio of boys to girls in part **b**?
- 2 The Tomslin family plans to drive the 856 km from Perth to Monkey Mia in Western Australia.
- At what speed should they travel, on average, if they hope to only take 10 hours?
 - The family left home at 6 a.m. and arrived at Monkey Mia at 8 p.m. How long did the trip take?
 - Calculate their average speed in part **b**. Answer to one decimal place.
 - How far could they have travelled at the speed in part **c** if they only drove for the original 10 hours as planned? Answer to the nearest km.



Chapter 2

Financial mathematics

Essential mathematics: why skills in financial mathematics are important

Skills in financial mathematics are essential for successful business management and for achieving personal financial independence. Percentage skills are needed for the financial calculations performed by individuals, accountants, bookkeepers, small business managers and employers. Percentages are used to calculate mark-up and discount amounts, cost prices and selling prices, profits, losses, insurance payments, GST, business tax, wage tax, wage increases and the interest on loans.

Personal income can be earned in various ways:

- a fixed salary p.a. ('per annum', i.e. per year), e.g. accountants, business owners, teachers, engineers, pharmacists and surveyors.
- a wage calculated from an hourly rate, e.g. chefs, cleaners, florists, dental assistants, nurses, receptionists, retail salespeople, construction workers, panel beaters and auto mechanics.
- by the job, e.g. personal trainers, fruit pickers, bricklayers, fishers, tailors, hairdressers, piano tuners and carpet layers.
- commission, e.g. car salespeople, real estate agents.



In this chapter

- 2A Percentages (**Consolidating**)
- 2B Applying percentages (**Consolidating**)
- 2C Percentage increase and decrease (**Consolidating**)
- 2D Profits and discounts (**Consolidating**)
- 2E Income
- 2F Taxation
- 2G Simple interest
- 2H Applications of simple interest

Australian Curriculum

NUMBER AND ALGEBRA

Money and financial mathematics

Solve problems involving simple interest (ACMNA211)

© Australian Curriculum, Assessment and Reporting Authority (ACARA)

Online resources

A host of additional online resources are included as part of your Interactive Textbook, including HOTmaths content, video demonstrations of all worked examples, auto-marked quizzes and much more.

1 Simplify:

a $\frac{12}{100}$

b $\frac{20}{100}$

c $\frac{35}{100}$

d $\frac{75}{100}$

e $\frac{60}{100}$

f $\frac{50}{100}$

2 Multiply these decimals by 100.

a 0.99

b 0.58

c 0.9

d 1.22

e 0.08

f 1.5

3 Which is larger in each of the following pairs?

a $\frac{1}{2}$ or 55%

b $\frac{3}{4}$ or 70%

c 0.89 or 98%

4 Copy and complete.

a $61\% = \frac{\square}{100}$

b $9\% = \frac{\square}{100}$

c $37\% = \frac{\square}{100}$

d $121\% = \frac{\square}{100}$

e $1\% = \frac{\square}{100}$

f $75\% = \frac{\square}{100} = \frac{3}{\square}$

5 Copy and complete the following table.

Fraction	Decimal	Percentage
$\frac{1}{100}$		
	0.1	
	0.25	
		50%
$\frac{3}{4}$		

6 Write down 10% of these amounts.

a 100 g

b 70 km

c \$450

d \$8000

e \$5

f 90c

7 Find:

a 25% of \$400

b 75% of 80 m

c 50% of \$3

d 10% of \$678

e 1% of 600 days

f $\frac{1}{2}\%$ of 600 days

8 Complete the following.

a 1% of 60 = 60 divided by \square

b 10% of 50 = 50 divided by \square

c 5% of 100 = 100 divided by \square

d $33\frac{1}{3}\%$ of 963 = 963 divided by \square

e 25% of 88 = 88 divided by \square

9 Find $33\frac{1}{3}\%$ of 6300 km.

10 Which is larger: 40% of 50 or 25% of 100?

11 Copy and complete:

a 1 week = \square days

b 1 year = \square days

c 1 year = \square weeks

d 1 year = \square months

12 How many hours are there from:

a 5 a.m. to 7 p.m.?

b 9 a.m. to 3 p.m.?

c 8:30 a.m. to 9 p.m.?

2A Percentages

CONSOLIDATING

Learning intentions

- To understand what a percentage represents
- To review how to convert between percentages and fractions or decimals
- To know common fraction, decimal and percentage conversions
- To be able to express one quantity as a percentage of another

Key vocabulary: percentage, fraction, decimal

We use percentages for many different things in our daily lives. Some examples include home loans, credit cards, sales and profits.

We know from our previous work on percentages that they represent a fraction with a denominator of 100. 'Per cent' comes from the Latin word *per centum*, and means 'out of 100'.

→ Lesson starter: Ordering with percentages

Ten different values are given below.

$$\frac{1}{2}, 0.8, 0.05, 15\%, \frac{7}{20}, 0.9, 9\%, \frac{3}{5}, \frac{1}{3}, 0.3$$

In pairs, decide:

- a** which of the numbers is the smallest **b** which of the numbers is the largest

Write the 10 numbers in ascending order.

Key ideas

- A **percentage** is the number of parts out of 100.
- Converting percentages
 - To change a decimal or a fraction into a percentage, *multiply* by 100.
 - For example: $\frac{1}{2} \times 100 = 50$ so $\frac{1}{2} = 50\%$
 - To convert a percentage into a fraction, *divide* by 100, using fraction notation. For example: $37\% = \frac{37}{100}$
 - To convert a percentage into a decimal, *divide* by 100.
For example: $8\% = 8 \div 100 = 0.08$
- Percentage composition
 - To express one quantity as a percentage of another, write them as a fraction, making sure the units are the same. Then convert this fraction to a percentage by multiplying by 100.
For example: 8 grams out of 32 grams $= \frac{8}{32} \times 100 = 25\%$
- It is useful to memorise some common fraction/decimal/percentage conversions.

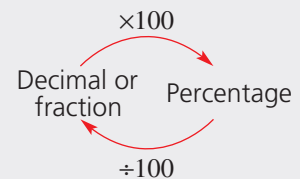

Fraction	1	$\frac{1}{2}$	$\frac{1}{3}$	$\frac{1}{4}$	$\frac{1}{5}$	$\frac{1}{10}$	$\frac{1}{20}$	$\frac{1}{50}$	$\frac{1}{100}$
Decimal	1	0.5	0.3	0.25	0.2	0.1	0.05	0.02	0.01
Percentage	100%	50%	$33\frac{1}{3}\%$	25%	20%	10%	5%	2%	1%

Exercise 2A

Understanding

1–4

1, 4

- Complete the following using the words multiply or divide.
 - To convert a decimal into a percentage _____ by 100.
 - To convert a percentage into a fraction _____ by 100.
 - To convert a fraction into a percentage _____ by 100.
 - To convert a percentage into a decimal _____ by 100.
- Copy and complete this table of common percentages.

%	10%			50%			
Fraction			$\frac{1}{4}$			$\frac{1}{3}$	$\frac{2}{3}$
Decimal		0.2			0.75		

- What percentage of each of the following diagrams has been shaded?

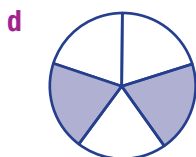
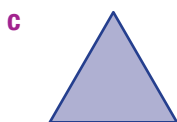
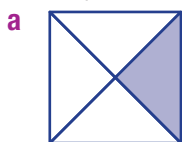

- Scott scored 38 out of 50 on a maths quiz and Sarah scored 79% on the same test. Who scored the higher mark?

Hint: Consider common fractions and percentages for the shaded areas.



Fluency

5–9(½)

5–9(½)



Example 1 Percentages and fractions

a Write $\frac{12}{25}$ as a percentage.

Solution

$$\begin{aligned} \text{a } \frac{12}{25} &= \frac{12}{25} \times 100 \\ &= 48\% \end{aligned}$$

b Write 7.5% as a fraction.

Explanation

Multiply the fraction by 100.

$$\frac{12}{25} \times 100 = \frac{12}{25_1} \times \frac{100^4}{1}$$

$$\begin{aligned} \text{b } 7.5\% &= \frac{7.5}{100} \\ &= \frac{15}{200} \\ &= \frac{3}{40} \end{aligned}$$

Write the percentage as a fraction, using a denominator of 100, $\frac{7.5}{100}$.

Multiply this fraction by $\frac{2}{2}$ so that we don't have a decimal in the fraction and it will be easier to simplify. $\frac{7.5}{100} \times \frac{2}{2} = \frac{15}{200}$

Simplify: $\frac{15}{200} = \frac{3}{40}$ by cancelling a common factor of 5.

Now you try

a Write $\frac{11}{20}$ as a percentage.

b Write 12.5% as a fraction.

5 Express the following fractions as percentages.

a $\frac{1}{5}$

b $\frac{4}{5}$

c $\frac{8}{10}$

d $\frac{3}{10}$

e $\frac{1}{4}$

f $\frac{1}{8}$

g $\frac{3}{4}$

h $\frac{12}{20}$

i $\frac{14}{25}$

j $\frac{7}{20}$

k $\frac{9}{100}$

l $\frac{3}{40}$

Hint: Multiply by 100.



6 Express the following percentages as simplified fractions.

a 19%

b 23%

c 99%

d 5%

e 22%

f 45%

g 74%

h 75%

i 2.5%

j 17.25%

k 1%

l 125%

Hint: Divide by 100.



Example 2 Converting between percentages and decimals

a Write 0.45 as a percentage.

b Write 25% as a decimal.

Solution

Explanation

a $0.45 = 0.45 \times 100 = 45\%$

Multiply by 100. This moves the decimal point two places to the right.

b $25\% = 25 \div 100 = 0.25$

Divide by 100. This moves the decimal point two places to the left.

Now you try

a Write 0.23 as a percentage.

b Write 48% as a decimal.

7 Express the following decimals as percentages.

a 0.78

b 0.95

c 0.65

d 0.48

e 0.75

f 1.42

g 0.07

h 0.3

i 0.03

j 1.04

k 0.12

l 0.1225

Hint: Move the decimal point two places to the right.



2A

8 Express the following percentages as decimals.

a 12%

b 83%

c 57%

d 88%

e 99%

f 100%

g 120%

h 5%



Example 3 Writing a quantity as a percentage

Write 50c out of \$2.50 as a percentage.

Solution

$$\begin{aligned} 50\text{c out of } \$2.50 &= \frac{1\cancel{50}}{5\cancel{250}} \times 100 \\ &= 20\% \end{aligned}$$

Explanation

Convert to the same units (\$2.50 = 250c) and write as a fraction. Multiply by 100, cancelling first.

Now you try

Write 90c out of \$3.60 as a percentage.

9 In each of the following cases, express the first quantity as a percentage of the second.

a 5 g out of 200 g

b 40c out of \$4

c 10 km out of 200 km

d 3 s out of 1 minute

e 200 m out of 1 km

f 100 mL out of $\frac{1}{2}$ L

g 200c out of \$1

h 45 marks out of a possible 60 marks

Hint: Write as a fraction and then multiply by 100.



Problem-solving and reasoning

10–12

11–14

10 Copy and complete the table of the favourite summer sports of Year 9 students.

Sport	Number of students who chose sport	Fraction of the total	Percentage of the total
Swimming	44		
Golf	12		
Volleyball	58		
Cricket	36		
Total			

11 Toni pays 31.5 cents in the dollar in tax. Express this as a percentage.

 12 Bad weather stopped a cricket game for 35 minutes of a scheduled $3\frac{1}{2}$ hour match. What percentage of the scheduled time was lost?

 13 Joe lost 4 kg and now weighs 60 kg. What percentage of his original weight did he lose?



Hint: What was Joe's original weight?



-  **14** A company claims that the apple pies it makes are 97% fat free. If the nutritional information on the side of the pack states that total fat is 7 grams of the 250 gram pie, is the claim correct?



Today's timeline

15

-  **15** Complete this table by filling in estimated times. In the first two columns, insert the times that you did each activity. Use that information to help you fill in the other columns. Round percentages to one decimal place.

a	Time you went to bed last night:	Time you woke up this morning:	Hours and minutes spent in bed:	Percentage of a day spent in bed:
b	Time you started breakfast today:	Time you finished breakfast today:	Minutes spent eating breakfast:	Percentage of the day you spent at breakfast:
c	Time school started today:	Time school is due to finish today:	Hours and minutes spent at school:	Percentage of the day spent at school:
d	Time this maths lesson started:	Time this maths lesson will finish:	Minutes spent in the maths lesson:	Percentage of the day spent in the maths lesson:
e	Time school will finish today:	Time you will arrive home:	Minutes spent travelling home:	Percentage of the day spent travelling home:
f	Time you started your homework yesterday:	Time you finished your homework yesterday:	Minutes spent on homework:	Percentage of your day spent on homework:
g	Time you started watching TV or playing games yesterday:	Time you finished watching TV or playing games:	Minutes spent at this activity:	Percentage of the day spent at this activity:
h	Time you woke up today:	Time you will go to bed tonight:	Hours and minutes spent awake today:	Percentage of the day spent awake:



2B Applying percentages

CONSOLIDATING

Learning intentions

- To know how to find a percentage of an amount using a fraction or decimal
- To be able to find the original amount from a given percentage

Key vocabulary: percentage, unitary method

The media often quotes percentages in news stories and advertisements. For example:

- 90% of dentists prefer this toothbrush.
- A shirt is reduced by 45%.
- A swing of 5% towards the Liberals is expected in the next election.

These examples involve finding a percentage of a quantity or amount and this is an important part of the work we do with percentages.



→ Lesson starter: Today's news challenge

In pairs, go through today's newspaper or online news site and find articles and advertisements that use percentages. Choose two and explain to the class how percentages are used in the articles you choose.

Key ideas

- To find a percentage of an amount, write the percentage as a fraction or a decimal, then multiply by the amount.

For example: 3% of $200 = \frac{3}{100} \times 200$ or $0.03 \times 200 = 6$

- To find the original amount when given a percentage, you can work backwards using the **unitary method** (finding the value of 1 unit first).

For example: *3% of an amount is 9. What is the original amount?*

Dividing both numbers by 3 gives 1% of the amount = 3

To find 100%, multiply 3 by 100 so 100% of the amount is 300.

Exercise 2B

Understanding

1–3

3

1 State if the following are true or false.

- a** 34% of $568 = 0.34 \times 568$ **b** 6% of $81 = 0.6 \times 81$
c 17% of $50 = \frac{17}{50} \times 100$ **d** 12% of $75 = \frac{3}{25} \times 75$

2 Find 1% of the amount if:

- a** 5% of the amount is 60 **b** 7% of the amount is 63 **c** 20% of the amount is 120

3 **a** If 1% of an amount is \$4, what is 100% of the amount?

- b** If 1% of an amount is \$7.50, what is 100% of the amount?

Fluency

4–6(½)

4–7(½)



Example 4 Finding a percentage of a quantity

Find 15% of \$35.

Solution

$$15\% \text{ of } \$35 = \frac{15}{100} \times \$35$$

$$= \$5.25$$

Explanation

Write the percentage as a fraction out of 100 and multiply by \$35.

Or write 0.15×35 .

Note: 'of' means to 'multiply'.

Now you try

Find 18% of \$60.

4 Find the following amounts.

a 10% of 20

b 5% of 200

c 20% of 40

d 15% of 50

e 8% of 720

f 5% of 680

g 15% of 8200

h 70% of 60

i 90% of 500

j 75% of 44

k 99% of 200

l 3% of 50

Hint: $10\% \text{ of } 20 = \frac{10}{100} \times 20$ 

5 Find:

a 10% of \$360

b 50% of \$420

c 75% of 64 kg

d 12.5% of 240 km

e 37.5% of 40 apples

f 87.5% of 400 m

g $33\frac{1}{3}\%$ of 750 peopleh $66\frac{2}{3}\%$ of 300 carsi $8\frac{3}{4}\%$ of \$560

Example 5 Finding the original amount given a percentage amount

Determine the original amount if 5% of the amount is \$45.

Solution

5% of the amount = \$45

1% of the amount = \$9

100% of the amount = \$900

So the original amount is \$900

Alternate method: 5% of $A = \$45$

$$0.05 \times A = \$45$$

$$A = \$45 \div 0.05$$

$$= \$900$$

Explanation

To use the unitary method, find the value of 1 part or 1% then multiply by 100 to find 100%.

Write an equation using the pronumeral A to represent the amount.Solve for A by dividing both sides by 0.05.**Now you try**

Determine the original amount if 8% of the amount is \$40.

2B



- 6 Determine the original amount if:
- a** 10% of the amount is \$12 **b** 6% of the amount is \$42
c 3% of the amount is \$9 **d** 40% of the amount is \$2.80
e 90% of the amount is \$0.18 **f** 6% of the amount is \$27
g 12% of the amount is \$96 **h** 15% of the amount is \$54

Hint: First find the value of 1%.



- 7 Determine the value of x in the following if:
- a** 10% of x is \$54 **b** 15% of x is \$90
c 25% of x is \$127 **d** 18% of x is \$225
e 105% of x is \$126 **f** 110% of x is \$44

Hint: x is the original amount.



Problem-solving and reasoning

8–11

8(½), 11–14

- 8 Without a calculator, evaluate the following.
- a** 10% of \$58 **b** 5% of \$84 **c** 1% of \$46
d $2\frac{1}{2}\%$ of \$20 **e** $33\frac{1}{3}\%$ of \$132 **f** $66\frac{2}{3}\%$ of \$60

Hint: $33\frac{1}{3}\% = \frac{1}{3}$



- 9 If $\frac{1}{3}$ of 96 = 32, what is $66\frac{2}{3}\%$ of 96?
- 10 If 10% of \$800 is \$80, explain how you can use this result to find:
- a** 1% of \$800 **b** 5% of \$800 **c** $2\frac{1}{2}\%$ of \$800
- 11 About 80% of the mass of the human body is water. If Carla weighs 60 kg, how many kilograms of water make up her body weight?
- 12 In a class of 25 students, 40% have been to England. How many students have not been to England?



- 13 Explain why 10% of 24 = 24% of 10.
- 14 10% of 1 day is the same as x hours and y minutes. What is the value of x and y ?



More than 100%

—

15



- 15 **a** Find 120% of 60.
b Determine the value of x if 165% of $x = 1.5$.
c Write 2.80 as a percentage.
d Write 325% as a fraction.
e \$2000 in a bank account increases to \$5000 over a period of time. By how much has the amount increased as a percentage?

2C Percentage increase and decrease

CONSOLIDATING

Learning intentions

- To understand how to form the percentage amount for a percentage increase or decrease
- To be able to increase or decrease an amount by a given percentage
- To know that percentage change is the percentage of the original amount
- To be able to calculate the percentage change

Key vocabulary: percentage

Percentages are often used to describe by how much a quantity has increased or decreased. The price of a car in the new year might be increased by 5%. On a \$70 000 car, this is a \$3500 increase. The price of a shirt might be marked down by 30%. If the shirt originally cost \$60, this provides an \$18 discount. It is important to note that the increase or decrease is calculated on the original amount.

→ Lesson starter: The quicker method

Two students, Nicky and Mila, consider the question: \$250 is increased by 15%. What is the final amount?

Nicky puts his solution on the board with two steps.

$$\begin{aligned} \text{Step 1: } 15\% \text{ of } \$250 &= 0.15 \times \$250 \\ &= \$37.50 \end{aligned}$$

$$\begin{aligned} \text{Step 2: } \text{Final amount} &= \$250 + \$37.50 \\ &= \$287.50 \end{aligned}$$

Mila says that the same problem can be solved with only one step using the number 1.15.

- Can you describe Mila's method? Write it down.
- What if the question was altered so that \$250 is decreased by 15%. How would Nicky's and Mila's methods work in this case?
- Which of the two methods do you prefer and why?



Key ideas

- To increase an amount by a given percentage:
 - add the percentage increase to 100%
 - multiply the amount by this new percentage.
 For example: to increase by 30%, multiply by $100\% + 30\% = 130\% = 1.3$
- To decrease an amount by a given percentage:
 - subtract the percentage from 100%
 - multiply the amount by this new percentage.
 For example: to decrease by 25%, multiply by $100\% - 25\% = 75\% = 0.75$
- To find a percentage change, use:

$$\text{Percentage change} = \frac{\text{change}}{\text{original amount}} \times 100\%$$

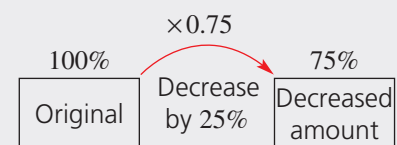
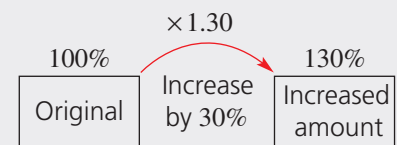

Exercise 2C

Understanding

1–3

3

- Write the missing number for these increases.
 - To increase a number by 40%, multiply by _____.
 - To increase a number by 26%, multiply by _____.
 - To increase a number by _____, multiply by 1.6.
 - To increase a number by _____, multiply by 1.21.
- Write the missing number for these decreases.
 - To decrease a number by 20%, multiply by _____.
 - To decrease a number by 73%, multiply by _____.
 - To decrease a number by _____, multiply by 0.94.
 - To decrease a number by _____, multiply by 0.31.
- Find the percentage change if
 - Original amount = \$120, change = \$30
 - Original amount = \$35, change = \$70

Hint: To increase by 40%, need 140% of amount



Hint: To decrease by 20%, need 80% of amount



Fluency

4–5(½), 6, 7

4–5(½), 6, 7(½), 8

Example 6 Increasing by a percentage

Increase \$70 by 15%

Solution

$$\begin{aligned} 100\% + 15\% &= 115\% \\ &= 1.15 \end{aligned}$$

$$\$70 \times 1.15 = \$80.50$$

Explanation

First add 15% to 100%

Note that 15% = 0.15 and 100% = 1

Multiply by 1.15 to give \$70 plus the increase in one step.

Now you try

Increase \$120 by 30%



- Complete the following.
 - Increase 56 by 10%
 - Increase 980 by 20%
 - Increase 100 by 12%
 - Increase 890 by 5%
 - Increase 180 by 15%
 - Increase 450 by 20%
 - Increase 8 by 50%
 - Increase 98 by 100%

**Example 7 Decreasing by a percentage**

Decrease \$5.20 by 40%

Solution

$$100\% - 40\% = 60\% \\ = 0.6$$

$$\$5.20 \times 0.6 = \$3.12$$

Explanation

First subtract the 40% from 100% to find the percentage remaining.

Multiply by 60% = 0.6 to get the result.

Now you try

Decrease \$64 by 15%



5 Complete the following.

a Decrease 80 by 5%

c Decrease 45 by 50%

e Decrease 8000 by 8%

g Decrease 68 by 75%

i Decrease 7000 by 100%

b Decrease 600 by 10%

d Decrease 700 by 12%

f Decrease 450 by 25%

h Decrease 9000 by 1%

j Decrease 10 000 by 1.5%

**Example 8 Finding a percentage change**

a The price of a mobile phone increased from \$250 to \$280. Find the percentage increase.

b The population of a town decreases from 3220 to 2985. Find the percentage decrease and round to one decimal place.

Solution

$$\text{a Increase} = \$280 - \$250 \\ = \$30$$

$$\text{Percentage increase} = \frac{30}{250} \times \frac{100}{1} \\ = 12\%$$

$$\text{b Decrease} = 3220 - 2985 \\ = 235$$

$$\text{Percentage decrease} = \frac{235}{3220} \times \frac{100}{1} \\ = 7.3\% \text{ (to 1 d.p.)}$$

Explanation

First find the actual increase.

Divide the increase by the original amount and multiply by 100.

First find the actual decrease.

Divide the decrease by the original population and multiply by 100. Round as indicated.

Now you try

a The height of a plant increased from 20 cm to 28 cm. Find the percentage increase.

b The price of a washing machine decreased from \$649 to \$545. Find the percentage decrease and round to one decimal place.

2C

- 6 The price of a flight increased from \$125 to \$150 overnight. Find the percentage increase.
- 7 Copy and complete the tables showing percentage change. Round to one decimal place where necessary.



a

Original amount	New amount	Increase	Percentage change
40	60		
12	16		
100	125		
24	30		
88	100		

b

Original amount	New amount	Decrease	Percentage change
90	81		
100	78		
20	15		
24	18		
150	50		



Example 9 Finding the original amount from an increase or decrease

After rain, the volume of water in a tank increased by 24% to 2200 L. How much water was in the tank before it rained? Round to the nearest litre.

Solution

$$100\% + 24\% = 124\%$$

$$124\% \text{ of original value} = 2200 \text{ L}$$

$$1\% \text{ of original value} = 17.74 \text{ L}$$

$$100\% \text{ of original value} = 1774 \text{ L}$$

Alternate method: $100\% + 24\% = 124\%$

$$124\% \text{ of } V = 2200 \text{ L}$$

$$1.24 \times V = 2200$$

$$V = 2200 \div 1.24$$

$$= 1774$$

Explanation

Write the total percentage.

The original volume is increased by 24% to give 2200 litres

Divide by 124 to find 1%

Multiply by 100 to find the original amount.

Write the total percentage.

Write an equation using the pronumeral V to represent the volume.

Divide both sides by 1.24 to solve for V .

Round to the nearest litre.

Now you try

At the start of a new year, daily public transport tickets increase by 4% to \$9.20. What was the cost of a daily ticket before the increase? Round to the nearest cent.









- 8 Find the original cost for each of the following if:
- an increase of 10% on the cost of a can of cola drink increased it to \$3.30
 - an increase of 10% on the cost of a meal increased the cost to \$88
 - after an increase of 5%, the cost of a pair of running shoes came to \$210
 - a decrease of 30% made the cost of car insurance \$350
 - a decrease of 60% brought the price of a used car down to \$5000



Problem-solving and reasoning

9–12

13–16

-  **9** The price of a computer was decreased by 15% in a sale. What is the sale price, if the original price was \$2100?
-  **10** Plumbers on a salary of \$82 570 were given a $2\frac{1}{2}\%$ pay increase. Find their new annual salary.
-  **11** A car manufacturer intends to increase sales by 14.7% next year. If the company sold 21 390 new cars this year, how many does it expect to sell next year?
- 12** The length of a bike sprint race is increased from 800 m to 1200 m. Find the percentage increase.
- 13** The number of people on a bus decreased from 25 to 18 after one stop. Find the percentage decrease in the number of people on the bus.
-  **14** After a price increase of 20%, the cost of entry to a museum rose to \$25.80. Find the original price.
-  **15** The total price of an item including GST (at 10%) is \$120. How much GST is paid, to the nearest cent?
-  **16** An investor starts with \$1000.
- After a bad day the initial investment is reduced by 10%. Find the balance at the end of the day.
 - The next day is better and the balance is increased by 10%. Find the balance at the end of the second day.
 - The initial amount decreased by 10% on the first day and increased by 10% on the second day. Explain why the balance on the second day didn't return to \$1000

Hint:

$$\% \text{ increase} = \frac{\text{increase}}{\text{original amount}} \times 100$$





Hint: \$120 represents 110% of the price before GST is added.



Repeated increase and decrease

—

17, 18

-  **17** If the cost of a pair of shoes was increased twice, by 10% from an original price of \$80 and then another 15% from this new price, the final price would be
- $$\$80 \times 1.10 \times 1.15 = \$101.20$$
- Use a similar technique to find the final price of these items. Round to the nearest cent.
- Skis starting at \$450 and increasing by 20% and 10%
 - A computer starting at \$2750 and increasing by 6% and 11%
 - A DVD player starting at \$280 and decreasing by 10% and 25%
 - A circular saw starting at \$119 and decreasing by 18% and 37%
-  **18** If an amount is increased by the same percentage each time, powers can be used. For example, 50 kg increased by 12% three times would increase to
- $$50 \text{ kg} \times 1.12 \times 1.12 \times 1.12$$
- $$= 50 \text{ kg} \times (1.12)^3$$
- $$= 70.25 \text{ kg (to 2 d.p.)}$$
- Use a similar technique to find the final value in these situations. Round to two decimal places.
- The mass of a rat initially at 60 grams grows at a rate of 10% every month for 3 months.
 - The cost of a new car initially at \$80 000 increases by 5% every year for 4 years.
 - The value of an apartment initially at \$380 000 decreases by 4% per year for 3 years.
 - The length of a pencil initially at 16 cm decreases through being sharpened by 15% every week for 5 weeks.

Hint: You have a power/index key on your calculator.



2D

2D Profits and discounts

CONSOLIDATING

Learning intentions

- To know the terms associated with profits and discounts
- To be able to find the selling price or original cost price from a mark-up or discount
- To be able to determine the profit or loss made on a sale

Key vocabulary: profit, selling price, cost price, loss, mark-up, percentage, discount

Percentages are widely used in the world of finance. Profits, losses, commissions, discounts and taxation are often expressed and calculated using percentages.

→ Lesson starter: The best discount

Two book shops are selling the same book at a discounted price. The recommended retail price for the book is the same for both shops. Each shop has a sign near the book with the given details:

- Shop A. Discounted by 25%
- Shop B. Reduced by 20% then take a further 10% off that.

Which shop offers the bigger discount?
Is the difference equal to 5% of the retail price?

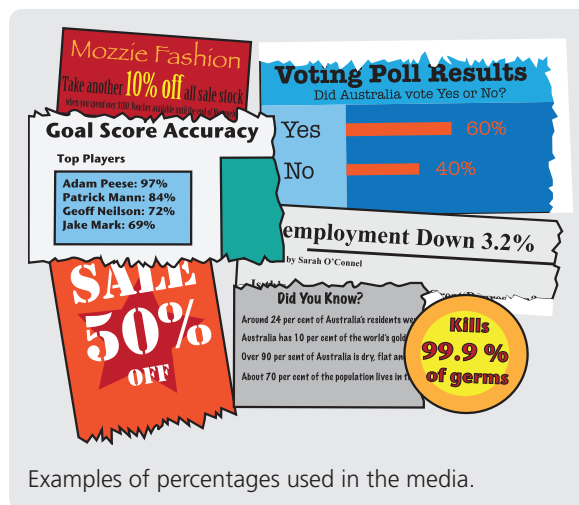

Key ideas

- Profit** is the amount of money made on a sale.
Profit = **selling price** – **cost price**
- A **loss** is made when the selling price is less than the cost price.
Loss = cost price – selling price
- Mark-up** is the amount added to the cost price to produce the selling price.
Selling price = cost price + mark-up
- The percentage profit or loss can be found by dividing the profit or loss by the cost price and multiplying by 100.

$$\% \text{ profit/loss} = \frac{\text{profit or loss}}{\text{cost price}} \times 100$$

- Discount** is the amount by which an item is marked down.
Discount = % discount × original price
New price = original price – discount amount

Exercise 2D

Understanding

1–4

1

- Match the definition in the left column with the correct word in the right-hand column.

<p>a The amount of money made on a sale</p> <p>b The amount by which an item is marked down</p> <p>c The result when the selling price is less than the cost price</p> <p>d The amount added to the cost price</p>	<p>A Loss</p> <p>B Mark-up</p> <p>C Profit</p> <p>D Discount</p>
--	--

- 2 Write the missing numbers in the table.

Cost price (\$)	7	18	460.95	3250
Selling price (\$)	10	15.50	395	4430
Profit/loss (\$)				

Hint: Profit/loss is the difference between cost price and selling price.
Mark up increases price.
Discount reduces price.



- 3 Copy and complete the table of mark-ups.

Cost price (\$)	30.95	99.95		18 000
Mark-up (\$)	10	80	700	
Selling price (\$)			1499.95	26 995

- 4 Copy and complete the table of discounts.

Original price (\$)	100	29.95		2215
New price (\$)	72	22.70	176	
Discount (\$)			23	178

Fluency

5–8

5–8



Example 10 Calculating selling price from mark-up

An electrical store marks up all entertainment systems by 30%.
If the cost price of one entertainment system is \$8000, what will be its selling price?

Solution

$$\begin{aligned}\text{Mark-up} &= 30\% \text{ of } \$8000 \\ &= 0.3 \times 8000 \\ &= \$2400\end{aligned}$$

$$\begin{aligned}\text{Selling price} &= \$8000 + \$2400 \\ &= \$10\,400\end{aligned}$$

Alternatively, multiply cost price by 130% or 1.3.

Explanation

Change percentage to a decimal or fraction and multiply by the cost price.

Selling price = cost price + mark-up

130% is a 30% increase on the cost price or 1.3.

Now you try

A computer store marks up all notebook computers by 24%.
If the cost price of one notebook is \$1200, what will be its selling price?



- 5 Copy and complete this table by calculating the selling price of each item.

Item	Cost price	% mark-up	Selling price
Jeans	\$60	28%	
Toaster	\$40	80%	
Car	\$22 000	45%	
Can of drink	\$1.20	140%	
Loaf of bread	\$1.80	85%	
Handbag	\$80	70%	
Electronic tablet	\$320	35%	



2D

Example 11 Finding the discount amount

An electrical store advertises a 15% discount on all equipment as a holiday special. Find the sale price on a projection system that has a marked price of \$18 000.

Solution

$$\begin{aligned}\text{Discount} &= 15\% \text{ of } \$18\,000 \\ &= 0.15 \times 18\,000 \\ &= \$2700\end{aligned}$$

$$\begin{aligned}\text{The new price} &= \$18\,000 - \$2700 \\ &= \$15\,300\end{aligned}$$

Alternatively, multiply the original price by 85% or 0.85.

Explanation

Change the percentage to a decimal and evaluate.

New price is original price minus discount.

A 15% discount leaves 85%.

Now you try

A department store offers a post-Christmas discount of 35% on all decorations. Find the sale price on a wreath that has a marked price of \$80.



6 Copy and complete the table by writing in the missing values.

Item	Cost price	% discount	Selling price
Camera	\$900	15%	
Car	\$24 000	20%	
Bike	\$600	25%	
Shoes	\$195	30%	
Blu-ray player	\$245	50%	
Electric razor	\$129	20%	
Lawn mower	\$880	5%	



Example 12 Determining profit

A manufacturer produces an item for \$400 and sells it for \$540.

- Determine the profit made.
- Express this profit as a percentage of the cost price.

Solution

$$\begin{aligned}\text{a Profit} &= \$540 - \$400 \\ &= \$140\end{aligned}$$

$$\begin{aligned}\text{b \% profit} &= \frac{140}{400} \times 100 \\ &= 35\%\end{aligned}$$

Explanation

$$\text{Profit} = \text{selling price} - \text{cost price}$$

$$\% \text{ profit} = \frac{\text{profit}}{\text{cost price}} \times 100$$

Now you try

A jeweller produces a necklace for \$36 and sells it for \$49.50.

- Determine the profit made.
- Express this profit as a percentage of the cost price.

-  **7** Find the missing values in these tables by finding the profit or loss and expressing this as a percentage of the cost price. Round to two decimal places where necessary.

a

Cost price (\$)	Selling price (\$)	Profit (\$)	Profit (%)
10	15		
24	30		
100	150		
250	255		
17.50	20		

b

Cost price (\$)	Selling price (\$)	Loss (\$)	Loss (%)
10	8		
16	12		
100	80		
34	19		
95	80.75		



Example 13 Calculating the original price

A toy store discounts a toy by 10% in a sale. If the sale price was \$10.80, what was the original price?

Solution

90% of the original = \$10.80

1% of the original = $10.80 \div 90$

1% of the original = 0.12

100% of the original = \$12

The original price was \$12.

Alternate method: 90% of P = \$10.80

$$0.9 \times P = \$10.80$$

$$P = \$10.80 \div 0.9$$

$$= \$12$$

Explanation

The discount factor = $100\% - 10\% = 90\%$.
Thus, \$10.80 is 90% of the original price.

Use the unitary method to find 1%.

Multiply by 100 to find the original amount.

Write the answer in words.

Write an equation using the pronumeral P to represent the original price.

Solve the equation for P by dividing both sides by 0.9

Now you try

An outdoor equipment store discounts a tent by 20% in a sale. If the sale price was \$176, what was the original price?



- 8** Answer the following questions relating to finding the original price (cost price).
- Find the original price if a coffee mug was discounted by 20% and sold for \$4.40.
 - Find the cost price of a pair of shoes that sold for \$250 after a mark-up of 25%.
 - Find the cost price after a discount of 10% was given on a surfboard that sold for \$1350.
 - Find the original price on a concert ticket for a major recording artist if it was marked up by 100% and sold for \$250.

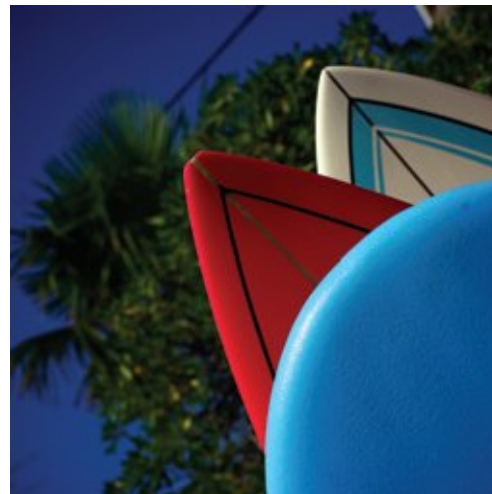

2D

Problem-solving and reasoning

9–11

11–13



- 9 A manufacturer produces and sells items for the prices shown.
- Determine the profit made.
 - Express this profit as a percentage of the cost price.
- a Cost price \$10, selling price \$12 b Cost price \$20, selling price \$25
c Cost price \$120, selling price \$136.80 d Cost price \$1400, selling price \$3850



- 10 Lenny marks up all computers in his store by 12.5%. If a computer cost him \$890, what will be the selling price of the computer?



- 11 A used-car dealer purchases a vehicle for \$13 000 and sells it for \$18 500. Determine the percentage mark-up on the vehicle to one decimal place.

Hint: What is the increase as a percentage of the original price?



- 12 A refrigerator is discounted by 25%. If Paula pays \$460 for it, what was the original price? Round to the nearest cent.



- 13 An electrical store buys a computer from the wholesaler for \$500. The store marks up the computer by 80%.

- What is the amount of the mark-up in dollars?
- What is the retail price of the computer after the store's mark-up?
- The store offers the computer on sale for a discount of 15%. What is the price now?
- If the 15% discount was calculated on the original \$500 cost price, and then the computer was marked up 80% after that, would it make a difference to the sale price?



House value

14

- 14 The graph shows the changes in the value of a particular house in southern Sydney.



- How much was the house worth in 1998?
- Find the percentage increase, to one decimal place, in the value of the house from 1998 to:
 - 2002
 - 2004
 - 2006
- In 2018 the owners wished to sell for 1.25 million dollars. What percentage increase was needed in the two years from 2016 to 2018 so they could sell for that price?

2E Income

Learning intentions

- To understand the different ways that workers can be paid
- To know how wages, overtime, salaries and commission work
- To be able to use wages and salaries to calculate hourly and yearly incomes
- To be able to calculate overtime earnings
- To be able to calculate commission on sales amounts

Key vocabulary: wage, overtime, time and a half, double time, salary, commission, retainer

There are many different ways of earning a living. You can be self-employed or work for someone else. Your income is usually related to the skills you have. It can be calculated and paid in different ways. You can earn, for example, a salary, a wage, a commission or possibly a royalty.

→ Lesson starter: Types of income

As a class, write down one example of a job that earns each of the following types of income.

- Salary
- Wage (i.e. hourly rate of pay)
- Overtime
- Commission

In the newspaper classifieds or online, find a job advertisement for each of the income types above.

Key ideas

- Workers who earn a **wage** (for example, a casual waiter) are paid a fixed rate per hour. Hours outside the normal working hours (public holidays etc.) are paid at a higher rate called **overtime**. This can occur in a couple of common ways:
 - **Time and a half:** pay is 1.5 times the usual hourly rate
 - **Double time:** pay is twice the usual hourly rate
- Workers who earn a **salary** (for example, an engineer) are paid a fixed amount per year, say, \$125 000. This is often paid monthly or fortnightly.
 - 12 months in a year and approximately 52 weeks in a year = 26 fortnights
- **Commission** is a proportion of the overall sales amount. Salespeople may receive a commission on their sales as well as a set weekly or monthly fee called a **retainer**.
 - $\text{Commission} = \% \text{ commission} \times \text{total sales}$

Exercise 2E

Understanding

1–4

1, 4

- 1 Match the pay description (a–d) with the income type (A–D).
- | | | | |
|---|---|---|------------|
| a | Sally earns \$22.70 per hour working in a shop | A | Overtime |
| b | Maths teacher Stephanie earns \$72 000 per year | B | Commission |
| c | Ross earns 5% of all sales he makes | C | Wage |
| d | Matt earns time and a half pay on Saturdays | D | Salary |

2E



- 2 Tom earns \$12.70 an hour. How much does he earn for:
a 2 hours of work? **b** 8 hours of work? **c** 38 hours of work?
- 3 Sela's hourly rate of pay is \$24. Calculate her overtime rate at:
a time and a half **b** double time
- 4 William earns a salary of \$136 875 each year. Approximately how much is this:
a each month?
b each week (to the nearest cent)?
c each day?



Hint: To find approximate monthly salary, divide annual salary by 12.
 To find approximate weekly salary, divide annual salary by 52.
 To find approximate daily salary, divide annual salary by 365.



Fluency

5–7, 8(½), 9

5, 6, 8(½), 9



Example 14 Comparing wages and salaries

Ken earns an annual salary of \$90 000 and works a 38-hour week. His wife Brooke works part time in retail and earns \$61.80 per hour.

- a** Calculate how much Ken earns per week.
b Determine who has the higher hourly rate of pay.
c If Brooke works on average 18 hours per week, what is her yearly income?

Solution



Explanation

- | | |
|--|--|
| a Weekly rate = $\$90\,000 \div 52$
= \$1730.77
∴ Ken earns \$1730.77 per week | \$90 000 pay in a year.
There are approximately 52 weeks in a year.
Divide by 52 to find the weekly wage. |
| b Brooke: \$61.80/h
Ken: $\$1730.77 \div 38$
= \$45.55/h
∴ Brooke is paid more per hour. | Ken works 38 hours in the week.
Hourly rate = weekly rate \div number of hours. Round to the nearest cent.
Compare hourly rates. |
| c In one week: $\$61.80 \times 18$
= \$1112.40
Yearly income = $\$1112.40 \times 52$
= \$57 844.80 | Weekly income = hourly rate \times number of hours
Multiply by 52 weeks to get yearly income. |

Now you try

Mali earns an annual salary of \$77 200 and works a 38-hour week. Her partner Ben works part time as a photographer and earns \$75 per hour.

- a** Calculate how much Mali earns per week.
b Determine who has the higher hourly rate of pay.
c If Ben works on average 15 hours per week, what is his yearly income from photography?

-  **5** Talib earns \$58 000 per year at a fast food restaurant. His sister works part time as a waitress and earns \$33.20 per hour.
- How much does Talib earn each week?
 - Each week Talib works 38 hours. Calculate if his hourly rate of pay is higher than his sister's.
 - If his sister averages 10 hours of work per week, what is her yearly income?
-  **6** Paul earns \$790 each week. How much does he earn each:
- year?
 - month?
 - hour, if he worked 40 hours each week?

Hint: There are 12 months in a year.



-  **7** Copy and complete the table.

Employee	Hourly rate	Hours worked	Income
Adam	\$20.40	8	
Betty	\$15.50	$8\frac{1}{2}$	
Ceanna	\$19.70	15	
David	\$24.30	38	
Edward	\$57.85	42	
Francis	\$30	27	
George	\$35.20	7.25	



Example 15 Calculating overtime

Georgio works some weekends and late nights, and earns overtime for that work. His hourly rate of pay is \$32 per hour.

- Calculate Georgio's time and a half rate of pay per hour.
- Calculate Georgio's double time rate of pay per hour.
- Calculate Georgio's weekly wage for a week where he works 18 hours at his normal rate, 2 hours at time and a half, and 1 hour at double time.

Solution

$$\begin{aligned} \text{a Time and a half} &= \$32 \times 1.5 \\ &= \$48 \end{aligned}$$

$$\begin{aligned} \text{b Double time} &= \$32 \times 2 \\ &= \$64 \end{aligned}$$

$$\begin{aligned} \text{c Wage} &= \$32 \times 18 + \$48 \times 2 + \$64 \times 1 \\ &= \$736 \end{aligned}$$

Explanation

Time and a half is 1.5 times the hourly rate.

Double time is 2 times the hourly rate.

Find the sum of:

- the normal hourly rate (\$32) multiplied by the number of hours worked at the normal rate (18)
- the time and a half hourly rate (\$48) multiplied by the number of hours worked at that rate (2)
- the double time hourly rate (\$64) multiplied by the number of hours worked at that rate (1).

Continued on next page

2E

Now you try

Kane works some weekends and some public holidays and earns overtime for that work. His hourly rate of pay is \$24 per hour.

- Calculate Kane's time and a half rate of pay per hour.
- Calculate Kane's double time rate of pay per hour.
- Calculate Kane's weekly wage for a week where he works 15 hours at his normal rate, 6 hours at time and a half and 3 hours at double time.



- 8 A job has a normal working hours pay rate of \$29.20 per hour. Calculate the pay, including overtime, from the following hours worked.

- 3 hours at the normal rate and 4 hours at time and a half
- 4 hours at the normal rate and 6 hours at time and a half
- 14 hours at the normal rate and 3 hours at double time
- 20 hours at the normal rate and 5 hours at double time
- 10 hours at the normal rate and 8 hours at time and a half and 3 hours at double time
- 34 hours at the normal rate and 4 hours at time and a half and 2 hours at double time

Hint: For time and a half: $\times 1.5$
For double time: $\times 2$



Example 16 Calculating commission

A part-time saleswoman is paid a retainer of \$1500 per month. She also receives a commission of 5% on the value of goods she sells. If she sells goods worth \$5600 during the month, calculate her earnings for that month.

Solution

$$\begin{aligned}\text{Commission} &= 5\% \text{ of } \$5600 \\ &= 0.05 \times \$5600 \\ &= \$280\end{aligned}$$

$$\begin{aligned}\text{Earnings} &= \$1500 + \$280 \\ &= \$1780\end{aligned}$$

Explanation

Calculate the commission on sales. Change the percentage to a decimal and evaluate.

Earnings = retainer + commission

Now you try

A real estate agent is paid a retainer of \$2200 per month. She also receives a commission of 0.4% on the value of houses she sells. If she sells houses worth \$1 575 000 during the month, calculate her earnings for that month.







- 9 Copy and complete the table.

Person	Weekly retainer	Rate of commission	Commission earned (\$)	Weekly wage (\$)
Adina	\$0	12% on \$7000		
Byron	\$160	8% on \$600		
Cindy	\$300	5% on \$680		
Deanne	\$260	5% on \$40 000		
Elizabeth	\$500	8% on \$5600		
Faruq	\$900	2% on \$110 000		
Gary	\$1000	1.5% on \$45 000		

Problem-solving and reasoning



10–12

11, 13–15

-  **10** Calculate how many hours at the standard hourly rate the following working hours are the same as:
- 3 hours and 2 hours at double time
 - 6 hours and 8 hours at time and a half
 - 15 hours and 12 hours at time and a half
-  **11** Jim, a part-time gardener, earned \$522 in a week. If he worked 12 hours during normal working hours and 4 hours overtime at time and a half, what was his hourly rate of pay?
-  **12** Sally earned \$658.80 in a week. She worked 10 hours during the week, 6 hours on Saturday at time and a half and 4 hours on Sunday at double time. What was her hourly rate of pay?
-  **13** Amy works at Best Bookshop. During one week she sells books valued at \$800. If she earns \$450 per week plus 5% commission, how much does she earn in this week?

Hint: Calculate the number of hours at the standard hourly rate.



-  **14** Jason works for a campervan company. If he sells \$84 000 worth of campervans in a month, and he earns \$1650 per month plus 4% commission on sales, how much does he earn that month?
-  **15** Stephen earns an hourly rate of \$34.60 for the first 38 hours, time and a half for the next 3 hours and double time for each extra hour above that. Calculate his earnings if he works 44 hours in a week.



Pay Slips

—

16

-  **16** Workers at a fast food restaurant are paid \$21.63 per hour for working Monday to Friday up until 7 p.m. and time and a half after 7 p.m. They earn time and a half on Saturdays and double time on Sundays. They are given an unpaid 30 minute meal break for any shift over 5 hours. Donna's shifts for the week are given below.

Monday	Tuesday	Wednesday	Thursday	Friday	Saturday	Sunday
–	4.30 p.m.– 7 p.m.	4.30 p.m.– 7.30 p.m.	5 p.m.– 10 p.m.	5 p.m.– 8 p.m.	10 a.m.– 6.30 p.m.	10 a.m.– 1.30 p.m.

- How much can Donna expect to earn, to the nearest cent, if she works the hours she is rostered for?
- The restaurant decides on a new workplace deal, gets rid of all overtime and creates a flat hourly rate of \$24 per hour. How much worse off will Donna be for the week above?
- How many extra hours a week does Donna need to work during the week to make up the extra income? Answer in a whole number of hours.

2A

- 1 Express the following in the required form.
- a** 32% as a simplified fraction
b 7% as a decimal
c 0.23 as a percentage
d 0.125 as a percentage
e $\frac{7}{20}$ as a percentage
f 4.5% as a simplified fraction

2A

- 2 Express the following as percentages.
- a** 20c out of \$2
b 32 marks out of 40
c 5 kg out of 40 kg

2B



- 3 Find the following amounts.
- a** 20% of 80 km
b 35% of \$120
c $33\frac{1}{3}\%$ of 180 g
d 4.2% of \$500

2B

- 4 Determine the original amount if:
- a** 25% of the amount is \$100
b 12% of the amount is \$36
c 8% of the amount is \$60

2C



- 5 Complete the following.
- a** Increase 82 by 10%
b Increase 220 by 8%
c Decrease 110 by 15%
d Decrease 250 by 6%

2C



- 6 **a** The number of students in a school increased from 450 to 540. Find the percentage increase.
b The cost of petrol dropped from 121c per litre to 103c per litre overnight. Find the percentage decrease correct to one decimal place.

2C



- 7 After offering a special ticket deal for students, a concert's ticket sales rose by 24% to 961 ticket sales. How many tickets had been sold before the ticket deal?

2D



- 8 Find the selling price of the following items.
- a** A \$1200 tablet computer marked up by 16%
b A pair of \$126 sneakers discounted by 20%

2D



- 9 Jane has a stall at the market selling bracelets that she makes. If each one costs \$6.20 to produce and she sells them for \$10, find her percentage profit correct to one decimal place.

2D



- 10 Find the original price if:
- a** a dress was discounted by 15% and sold for \$187
b a computer game was marked up by 12% and sold for \$72.80

2E



- 11 Find the weekly earnings in the following work situations.
- a** Seb earns an annual salary of \$74 100. (Assume 52 weeks in the year.)
b Jodie works 22 hours in a week at \$18.20 per hour.
c Ned works in a fast food restaurant and has a normal hourly rate of \$15.10 per hour. In a week he works 4 hours at the normal rate, 3 hours at time and a half and 2 hours at double time.
d Harper is paid a weekly retainer of \$200 and she also earns a 5% commission on her sales. In a particular week she makes \$8400 worth of sales.

2F Taxation

Learning intentions

- To know the difference between gross income and net income
- To understand how taxable income is determined
- To know what is meant by income tax
- To know how to calculate net income from gross income and deductions
- To be able to calculate tax as a percentage of the taxable income
- To be able to calculate income tax using the tax table from the Australian Taxation Office

Key vocabulary: gross income, net income, taxable income, income tax, deductions

All wage and salary earners have some deductions taken out of their pay. Deductions usually include income tax. Tax is paid to the government. The government uses it to pay for community welfare, education and a number of other services.



→ Lesson starter: Deductions from pay

What types of deductions can you and your class think of that might be taken out of someone's pay?

Discuss, as a class, what superannuation and the Medicare levy is, and who pays it.

Key ideas

- **Gross income** = the total of all income
- **Net income** = gross income minus **deductions** (expenses that reduce income)
- **Taxable income** = gross income minus tax deductions
- **Income tax** is paid to the government once a person's taxable income passes a set amount in the year.
- Income tax is calculated by the current tax table available through the Australian Taxation Office. The following rates apply as of 2019–20.

Taxable income	Tax on this income
\$0 – \$18 200	Nil
\$18 201 – \$37 000	19c for each \$1 over \$18 200
\$37 001 – \$80 000	\$3572 plus 32.5c for each \$1 over \$37 000
\$80 001 – \$180 000	\$17 547 plus 37c for each \$1 over \$80 000
\$180 001+	\$54 547 plus 45c for each \$1 over \$180 000*

* Does not include the Medicare levy (2% of taxable income).

Exercise 2F

Understanding

1–4

4

- 1 Copy and complete the table by inserting the net income amounts.

Gross income	Deductions	Net income
\$5600	\$450	
\$87 000	\$28 000	
\$50 000	\$6700	

Hint: Recall that net income = gross income minus deductions.



2F

- 2 Find Hoang's gross weekly income if he earns:
- \$1200 a week as a teacher
 - \$60 an hour for tutoring, and he tutors for 3 hours a week
 - \$25 in interest on his bank account per week
- 3 John has a gross income of \$45 000 and a net income of \$20 000. How much did his deductions come to?
- 4 Use the table in the Key ideas to interpret the tax paid on an income of
- a** \$12 000 **b** \$37 000 **c** \$80 000

Fluency

5–6(½), 7, 8(½)

5–6(½), 8(½)



Example 17 Calculating tax to find net income

Liam starts a new job with an annual salary of \$52 800. His payslip each month shows deductions for taxation of \$968.

- a** Calculate Liam's net income each month.
- b** What percentage of Liam's monthly pay is being paid to the government by his employer for taxation?
- c** Liam's salary is increased to \$65 000 and the taxation rate for Liam's salary changes to 24% with the first \$18 200 tax free. Calculate Liam's net income for the year.

Solution



Explanation

a	$\begin{aligned} \text{Monthly pay} &= \$52\,800 \div 12 \\ &= \$4400 \end{aligned}$	Calculate gross income per month.
	$\begin{aligned} \therefore \text{net monthly income} &= \$4400 - \$968 \\ &= \$3432 \end{aligned}$	Net income = gross income – taxation
b	$\begin{aligned} \% \text{ tax} &= \frac{968}{4400} \times 100 \\ &= 22\% \end{aligned}$	Calculate what fraction \$968 is of the monthly income \$4400. Multiply by 100 to convert to a percentage.
c	$\begin{aligned} \text{Salary for tax purposes} &= \$65\,000 - \$18\,200 \\ &= \$46\,800 \end{aligned}$	First \$18 200 is not taxed.
	$\begin{aligned} \text{Tax amount} &= 24\% \text{ of } \$46\,800 \\ &= 0.24 \times \$46\,800 \\ &= \$11\,232 \end{aligned}$	Calculate tax amount on \$46 800. Convert percentage to a decimal and evaluate.
	$\begin{aligned} \therefore \text{net income} &= \$65\,000 - \$11\,232 \\ &= \$53\,768 \end{aligned}$	Net income = gross income – tax amount.

Now you try

Poppy has a job with an annual salary of \$74 400. Her payslip each month shows deductions for taxation of \$1488.

- a** Calculate Poppy's net income each month.
- b** What percentage of Poppy's monthly pay is being paid to the government by her employer for taxation?
- c** Poppy's salary is increased to \$82 800 and the taxation rate for Poppy's salary changes to 28% with the first \$18 200 tax free. Calculate Poppy's net income for the year.

-  **5** For each of the following find:
- the annual net income
 - the percentage of gross income paid as tax. Round to one decimal place where necessary.
- Gross annual income = \$48 241, tax withdrawn = \$8206
 - Gross annual income = \$67 487, tax withdrawn = \$13 581.20
 - Gross monthly income = \$4041, tax withdrawn = \$606.15
 - Gross monthly income = \$3219, tax withdrawn = \$714.62
-  **6** Calculate the amount of tax to be paid using the following annual salaries and tax rates if the first \$18 200 is tax free.
- salary = \$30 400, tax rate = 15%
 - salary = \$56 500, tax rate = 21%
 - salary = \$69 700, tax rate = 24.5%
 - salary = \$96 400, tax rate = 30.4%
-  **7** Ed earns \$1400 per week and pays 27% of his annual income in tax.
- Calculate the amount of income tax that Ed pays in one year.
 - Find Ed's annual net income.

Hint: Net income =
gross income – deductions



Hint: Remember to subtract the
\$18 200 to find the salary to
calculate tax on.



Example 18 Using the tax table

Use the tax table below to find the income tax for an income of \$84 000.

Taxable income	Tax on this income
\$0 – \$18 200	Nil
\$18 201 – \$37 000	19c for each \$1 over \$18 200
\$37 001 – \$80 000	\$3572 plus 32.5c for each \$1 over \$37 000
\$80 001 – \$180 000	\$17 547 plus 37c for each \$1 over \$80 000
\$180 001+	\$54 547 plus 45c for each \$1 over \$180 000*

* Does not include the Medicare levy (2% of taxable income).

Solution

$$\begin{aligned} \text{Tax} &= \$17\,547 + 0.37 \times (\$84\,000 - \$80\,000) \\ &= \$17\,547 + \$1480 \\ &= \$19\,027 \end{aligned}$$

Explanation

Find the tax bracket in which the amount (\$84 000) lies (\$80 000 – \$180 000).

Write down the values in this bracket, remembering that 37c in the dollar is 37%, or 0.37.

Subtract 80 000 from 84 000 to find the amount of income that the 37% applies to.

Use your calculator to find the answer.

Now you try

Use the tax table above to find the income tax for an income of \$75 000.

-  **8** Use the tax table in Example 18 to find the income tax payable on each of these incomes.
- \$10 000
 - \$30 000
 - \$50 000
 - \$80 000
 - \$129 000
 - \$156 000
 - \$200 000
 - \$500 000
 - \$1 000 000

Hint: Find the right category
(tax bracket) first.



2F

Problem-solving and reasoning

9, 10

9–12



-  **9** Mel has a net annual income of \$53 246 after 21% of her income is withdrawn for tax purposes. What was her gross income?

Hint: What % of gross income does \$53 246 represent?



-  **10** Fred earns \$50 000 each year as a shop clerk and an extra \$1200 each year for doing gardening on some weekends.
- Calculate his annual gross salary.
 - Use his gross salary to find his income tax, using the tax table in Example 18.
 - What is his annual net income, after tax?
 - What is his approximate fortnightly net income, to the nearest cent, after tax?



-  **11** William earns \$1600 a week. Using the tax table in Example 18, how much tax is deducted from his pay each week? Assume 52 weeks in a year.
-  **12** John pays \$5000 in tax a year.
- Which tax bracket does John fall into?
 - Work backwards from this amount to work out how much John earns per year. Answer to the nearest dollar.



Other types of deductions and taxable income

—



13–15

The lower a person's income, the less tax they must pay. People therefore try to lower their taxable income by claiming allowable tax deductions.

Work-related expenses such as uniforms, stationery and job-related travel expenses are all examples of allowable tax deductions. The income tax is therefore calculated on what we call a person's taxable income.

Taxable income = gross income – allowable tax deductions

Use the tax table from Example 18 to compare the following jobs.

-  **13** An young accountant earns \$3120 a fortnight, with no allowable tax deductions.
- What is the accountant's taxable income?
 - How much tax does the accountant owe in a year?
 - What is the accountant's annual net pay?
 - What is the accountant's fortnightly net pay?
-  **14** A young lawyer earns \$3120 a fortnight with allowable tax deductions totalling \$2560 a year.
- What is the lawyer's taxable income?
 - How much tax does the lawyer owe in a year?
 - What is the lawyer's annual net pay?
 - What is the lawyer's fortnightly net pay?



- 15** How much less money does the lawyer in question **14** have each week compared to the accountant in question **13**?

2G Simple interest

Learning intentions

- To understand how simple interest is calculated
- To be able to calculate simple interest and the final amount
- To be able to calculate simple interest using different time periods

Key vocabulary: simple interest, principal, per annum

Interest is charged when a person or institution borrows money. The interest is an extra amount that must be paid back, on top of the borrowed amount.

Interest is also earned, when a person or institution invests money.

Simple or flat rate interest is usually charged or earned each year. It is calculated on the full amount borrowed or invested at the beginning of the loan.



→ Lesson starter: Developing the rule

\$5000 is invested in a bank and 5% simple interest is paid to the investor every year. In the table below, the amount of interest paid is shown for Year 1, and the amount of total interest is shown for Years 1 and 2.

- Complete the table.
- How much interest would the investor earn in 10 years?

Year	Interest paid that year	Total interest
0	\$0	\$0
1	$\frac{5}{100} \times \$5000 = \250	$1 \times \$250 = \250
2		$2 \times \$250 = \500
3		
4		
5		

Key ideas

- **Simple interest** is interest calculated each time period on the initial amount.
- To compute simple interest, we apply the formula:

$$I = \frac{Prt}{100} \text{ or } I = P \times \frac{r}{100} \times t$$

I is the amount of simple interest (in \$)

P is the **principal** amount; the money borrowed or invested (in \$)

r is the annual interest rate expressed as a percentage

t is the number of years

- The total amount (A) equals the principal plus interest

$$A = P + I$$

- p.a. means '**per annum**' or 'per year'.

Exercise 2G

Understanding

1–3

1, 2

- \$12 000 is invested at 6% p.a. for 42 months.
 - What is the principal amount?
 - What is the interest rate?
 - What is the time period in years?
- Jann earns \$560 p.a. in simple interest on an investment. How much would he earn on the investment in:
 - 2 years?
 - 5 years?
 - 10 years?

-  3 Use the rule $I = \frac{Prt}{100}$ to find the simple interest (I) earned in these financial situations.
- $P = \$10\,000$, $r = 10$, $t = 3$
 - $P = \$6000$, $r = 12$, $t = 5$
 - $P = \$5200$, $r = 4$, $t = 2$

Hint:
 I = interest
 P = principal
 r = interest rate
 t = time (years)



Fluency

4–6, 8

4, 6–8

Example 19 Using the simple interest formula

Calculate the simple interest earned if the principal is \$1000, the rate is 5% p.a. and the time is 3 years.

Solution

$$P = 1000, r = 5, t = 3$$

$$\begin{aligned} I &= \frac{Prt}{100} \\ &= \frac{1000 \times 5 \times 3}{100} \\ &= 150 \end{aligned}$$

$$\text{Interest} = \$150$$

Explanation

List the information given.

Write the formula and substitute the given values.

Cancel the zeros, leaving $10 \times 5 \times 3$.

Answer the question.

Now you try

Calculate the simple interest earned if the principal is \$2000, the rate is 4% p.a. and the time is 5 years.

-  4 Find the simple interest earned on:
- | | |
|--|--|
| a \$5000 at 6% p.a. for 1 year | b \$5000 at 6% p.a. for 3 years |
| c \$8000 at 4% p.a. for 5 years | d \$15 000 at 3% p.a. for 7 years |
| e \$7250 at 5.5% p.a. for 3 years | |

-  5 Wally invests \$15 000 at a rate of 6% p.a. for 3 years. Calculate the simple interest and the amount available at the end of 3 years.

Hint:
 Amount = principal + interest



**Example 20 Using other time periods**

Calculate the simple interest on \$7000 invested at $6\frac{1}{4}\%$ p.a. for 18 months.

Solution

$$P = 7000, r = 6\frac{1}{4} = 6.25$$

$$t = 18 \text{ months} = \frac{18}{12} \text{ or } 1.5 \text{ years}$$

$$I = \frac{Prt}{100}$$

$$I = \frac{7000 \times 6.25 \times 1.5}{100}$$

$$= 656.25$$

$$\text{Interest} = \$656.25$$

Explanation

List the information.

Convert 18 months into years by dividing by 12.

Write the formula.

Substitute in the values and evaluate.

Now you try

Calculate the simple interest on \$4500 invested at $5\frac{1}{2}\%$ for 30 months.



6 Calculate the simple interest earned on:

- \$500 at 7% p.a. for 18 months
- \$1000 at 5% p.a. for 24 months
- \$2000 at 4% p.a. for 6 months
- \$4700 at $4\frac{1}{2}\%$ p.a. for 15 months (Round to the nearest cent.)
- \$50 000 at 3.75% p.a. for 200 days (Round to the nearest cent.)

Hint: 365 days = 1 year

**Example 21 Calculating the final balance**

Allan and Rachel plan to invest some money for their child Kaylan. They invest \$4000 for 30 months in a bank that pays 4.5% p.a. Calculate the simple interest and the amount available at the end of the 30 months.

Solution

$$P = 4000, r = 4.5, t = \frac{30}{12} = 2.5$$

$$I = \frac{Prt}{100}$$

$$= \frac{4000 \times 4.5 \times 2.5}{100}$$

$$= 450$$

$$\text{Interest} = \$450$$

$$\text{Total amount} = \$4000 + \$450 = \$4450$$

Explanation

t is written in years since interest rate is per annum.

Write the formula, substitute and evaluate.

Total amount = principal + interest

Continued on next page

2G

Now you try

Joy wins some money which she decides to invest. She invests the \$5000 for 36 months in a bank account that pays 3.8% p.a. Calculate the simple interest and the amount available at the end of the 36 months.

-  7 Annie invests \$22 000 at a rate of 4% p.a. for 27 months. Calculate the simple interest and the amount available at the end of 27 months.



-  8 Copy and complete the table.

	Principal, P (\$)	Annual interest, rate, r	Time period, t	Interest, I	Final balance, $A = P + I$
a	7000	3%	4 years		
b	1500	7%	8 years		
c	40 000	2.5%	18 months		
d	70 000	$3\frac{1}{4}\%$	2 years		
e	2000	4%	30 months		

Problem-solving and reasoning

9, 10

10, 11

-  9 A finance company charges 14% p.a. simple interest. If Lyn borrows \$2000 to be repaid over 2 years, calculate her total repayment.
- 10 Markus borrows \$20 000 to buy a car. He is charged simple interest at 18% p.a. for a period of 5 years.
- How much interest is Markus charged each year?
 - Calculate the total interest Markus will pay on this loan.
 - What is the total amount that Markus will have paid at the end of the loan period?
-  11 Wendy wins \$5000 during a chess tournament. She wishes to invest her winnings, and has the two choices given below. Which one gives her the greater total at the end of the time?
- Choice 1: 8.5% p.a. simple interest for 4 years
- Choice 2: 8% p.a. simple interest for 54 months





Simple interest tables and graphs

12, 13



- 12 The table shows the amount of simple interest payable (in \$, to the nearest \$) on loans at a certain interest rate.

Amount of loan	1 year	2 years	3 years	5 years	10 years
50	6	13	19	32	65
100	13	26	39	65	129
500	65	129	194	323	645
1000	129	258	387	645	1290
5000	645	1290	1935	3225	6450
10 000	1290	2580	3870	6450	12 900
50 000	6450	12 900	19 350	32 250	64 500
100 000	12 900	25 800	38 700	64 500	129 000

Use the table to find the interest payable on the following loans.

- a** \$5000 for 1 year **b** \$500 for 3 years **c** \$100 for 10 years
d \$150 for 1 year **e** \$85 500 for 5 years **f** \$9550 for 10 years
g \$5000 for 4 years **h** \$50 000 for 9 years **i** \$100 000 for 10 years

- 13 The graph on the right shows the annual interest earned on investments for interest rates of 4% p.a. and 6% p.a. Use the graph to answer the following.

- a** Find the annual interest earned on an investment of:
i \$300 at 4% p.a.
ii \$520 at 6% p.a.
iii \$250 at 4% p.a.
- b** What investments would earn annual interest of (to the nearest \$):
i \$20 at 6% p.a.?
ii \$20 at 4% p.a.?
iii \$14 at 6% p.a.?

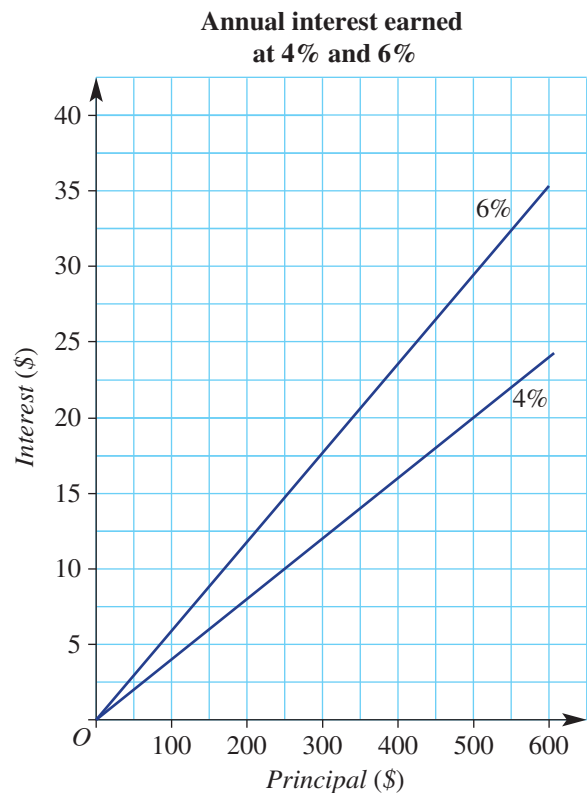

2H

2H Applications of simple interest

Learning intentions

- To be able to use the simple interest formula to calculate the investment period, interest rate or principal
- To be able to calculate repayment amounts given the terms of the deal

Key vocabulary: simple interest, principal, repayment

Financial calculations are a critical component of the thinking behind the decisions people make as to where to borrow or invest money.



→ Lesson starter: Where do I invest?

Bank A: \$4000 at 5% p.a. for 8 years

Bank B: \$5000 at 8% p.a. for 4 years

Bank C: \$8000 at 4% p.a. for 5 years

Calculate the simple interest earned on each investment option. What do you notice?
Which bank would you choose and why?

Key ideas

- The simple interest formula, $I = \frac{Prt}{100}$, can be used to calculate any of I , P , r or t depending on what other information is given.
 - To find an unknown, substitute the given information and solve for the unknown.
- To repay a loan, you must repay the amount borrowed (the principal) and the interest.
- **Repayments** are the amount of money, usually the same amount each time period, used to repay a loan.

Exercise 2H

Understanding

1–4

4

- If Phil earns \$100 in simple interest in one year, how long would it take him to earn:

a \$200 b \$400 c \$5000 d \$250
- How many years does it take for \$100 to earn \$50 in interest if the simple interest rate is 10% p.a.?
- Jodie repays \$200 a month for 12 months to pay back her loan and interest. How much does she repay?
- A loan of \$4000 has interest of \$500 added to it. Calculate the size of each of the 10 repayments needed to repay the loan.

Hint:
How much interest is earned on \$100 at 10% p.a. for 1 year?



Fluency

5, 6, 8, 9

5, 7, 8, 9



Example 22 Determining the investment period

Remy invests \$2500 at 8% p.a. simple interest, for a period of time, to produce \$50 interest. For how long did she invest the money?

Solution

$$I = 50, P = 2500, r = 8$$

$$I = \frac{Prt}{100}$$

$$50 = \frac{2500 \times 8 \times t}{100}$$

$$50 = 200t$$

$$\therefore t = \frac{50}{200}$$

$$= 0.25$$

$$\text{Time} = 0.25 \text{ years}$$

$$= 0.25 \times 12 \text{ months}$$

$$= 3 \text{ months}$$

Explanation

List the information.

Write the formula.

Substitute the known information and simplify.

Solve the remaining equation for t by dividing both sides by 200.

Convert decimal time to months where appropriate.

Now you try

Jas invests \$3000 at 6% p.a. simple interest, for a period of time, to produce \$450 interest. For how long did he invest the money?



5 Alvi invests \$5000 at 8% p.a. simple interest and wants to earn \$1200 in interest. For how many years should Alvi invest his money?



6 Sam earns \$288 interest on his \$1600 investment. If the interest was calculated at 4% p.a., how many years did Sam invest the money for?



7 \$8000 earns \$600 interest at 5% p.a. over how many months?



Example 23 Determining the interest rate

Bank East advertises \$450 interest a year on an investment of \$7500. Calculate the simple interest rate for this investment.

Solution

$$I = 450, P = 7500, t = 1, r = ?$$

$$I = \frac{Prt}{100}$$

$$450 = \frac{7500 \times r \times 1}{100}$$

$$450 = 75 \times r$$

$$r = 450 \div 75$$

$$r = 6$$

Interest rate is 6% p.a.

Explanation

List the information.

Write the formula and substitute $I = 450$, $P = 7500$ and $t = 1$.

Simplify and solve for r .

Write r as a percentage.

Continued on next page

2H

Now you try

Oz Loans offers \$610 interest a year on an investment of \$12 200. Calculate the simple interest rate for this investment.



- 8 Find the annual simple interest rate needed for each of the following situations.

- | | |
|---|---|
| a \$4000 earns \$500 in 2 years | b \$500 earns \$120 in 12 years |
| c \$18 000 earns \$3510 in 3 years | d \$950 earns \$470.25 in 9 years |
| e \$3000 earns \$945 in 18 months | f \$2500 earns \$393.75 in 4.5 years |

Hint: Set up the formula $I = \frac{Prt}{100}$ where r is the unknown.



Example 24 Calculating repayments

'Deals 4 You' offers a loan of \$24 000 at 16% p.a. simple interest if the loan is repaid in equal monthly instalments over 5 years.

- How much interest is charged on the loan?
- What is the total amount of the loan and the interest?
- Calculate the size of each repayment.

Solution

Explanation

$$\mathbf{a} \quad I = \frac{Prt}{100}$$

$$P = 24\,000, r = 16, t = 5$$

$$\therefore I = \frac{24\,000 \times 16 \times 5}{100}$$

$$= \$19\,200$$

$$\mathbf{b} \quad \text{Total} = \$24\,000 + \$19\,200 \\ = \$43\,200$$

$$\mathbf{c} \quad \text{Repayments} = \frac{43\,200}{60} \\ = 720$$

Repayments come to \$720 a month.

Write down the simple interest formula and list the information.

Substitute in the values and evaluate.

Total = principal + interest

Divide the total amount by the number of months in 5 years ($5 \times 12 = 60$).

Now you try

A loan of \$35 000 is repaid in equal monthly instalments over 6 years at 8% p.a. simple interest.

- How much interest is charged on the loan?
- What is the total amount of the loan and the interest?
- Calculate the size of each repayment.

- 9 Copy and complete this table and find the monthly repayment for each loan.



Amount borrowed	Annual simple interest rate	Number of years	Interest	Total amount to be repaid	Monthly repayment
\$5000	21%	5			
\$14 000	15%	5			
\$10 000	6%	4			
\$55 000	8%	10			
\$250 000	7%	30			

Problem-solving and reasoning

10, 11

10, 12, 13

- 10 Calculate the principal amount which earns \$500 simple interest over 3 years at a rate of 8% p.a. Round to the nearest cent.

Hint: Substitute into $I = \frac{Prt}{100}$ and solve for P .



- 11 Charlotte borrows \$9000 to buy a second-hand car. The loan must be repaid over 5 years at 12% p.a. simple interest. Calculate:
- the total amount to be repaid
 - the monthly repayment amount if the repayments are spread equally over the 5 years



- 12 If \$5000 grows to \$11 000 in 12 years, find the simple interest rate.

- 13 An investor invests \$ P and wants to double this amount of money.

- How much interest must be earned to double this initial amount?
- What simple interest rate is required to double the initial amount in 8 years?
- If the simple interest rate is 5% p.a.:
 - how many years will it take to double the investment?
 - how many years will it take to triple the investment amount?
 - how do the investment periods in parts **i** and **ii** compare?



2H



Compound interest

14, 15

With simple interest, the principal and the interest earned each year remain the same for the period of the investment.

However, with compound interest, each time the interest is calculated it is added to the principal to give a new value. This means that the next time the interest is calculated, it is done so using a larger amount.

In the following questions you will be asked to do repeated applications of simple interest to find the final compounded amount.

14 \$500 is invested for 4 years at 10% p.a. interest compounded annually.

a Complete the table to find the final value of the investment at the end of this time and the total.

Time (years)	Amount (A)	Interest (I)	New amount (A + I)
1	500	$500 \times 0.1 = 50$	$500 + 50 = 550$
2	550	$550 \times 0.1 =$	
3			
4			

b How much interest did the investment earn over the 4 years?



15 a Complete the following table to find the final value of an investment of \$4500 compounded at 5% p.a. annually for 5 years.

Time (years)	Amount (A)	Interest (I)	New amount (A + I)
1	4500	225	4725
2	4725		
3			
4			
5			

b Type 4500×1.05^5 into your calculator. What do you notice about this answer?

c Can you explain how the answers to part **a** and part **b** relate?

d Use the formula $r = \frac{100I}{Pt}$ to find out what simple interest rate would be needed to create the same final amount over the 5 years. Answer correct to one decimal place.



Maths@Work: Facebook cake-decorating business

More and more individuals are setting up a business using Facebook. For example, a successful cake-decorating business can be run from home while looking after the kids or while working normal business hours at other jobs.

As with any business, an understanding of financial mathematics is important to the success of the business. Skills such as calculating costs and profits, percentages and taxation are important for any manager.



- Calculate the total cost of buying each of the following cake tin sets:
 Round set: 6, 8, 9 and 12 inches by 3 inches deep at \$64.
 Round set: 6, 8, 10 and 12 inches by 4 inches deep at \$99.
 Square set: 6, 8 and 10 inches by 3 inches deep at \$45.
 Square set: 6, 8, 10 and 12 inches by 4 inches deep at \$86.
- Convert the following measurements from inches (US standard) to whole number of centimetres by using the following conversion rate: 1 inch = 2.54 cm.
 - 3 inches
 - 4 inches
 - 9 inches
 - 10 inches
- Imagine that you spend 2 hours out of $9\frac{1}{2}$ work hours on the internet promoting your business. Write this as a percentage, rounded to the nearest whole percentage.
- Fondant icing comes in different colours and in different-sized tubes. Managing your budget means looking for the best buy.
 - Which of the following represents the best buy for each colour of fondant listed below?

White fondant	Red fondant	Blue fondant
100 g at \$3.25	2.5 kg at \$36.95	100 g at \$2.95
500 g at \$5.50	1 kg at \$19.90	500 g at \$7.95
5 kg at \$40	100 g at \$3.25	750 g at \$11.95
1 kg at \$10.50	500 g at \$7.95	1 kg at \$19.90

- What is the average cost per 100 grams for white fondant icing?
- Under what circumstances would someone buy a size that was not the best buy?

- 5 A customer has the following quotes for a large 21st birthday cake from four different Facebook cake suppliers: \$195, \$290, \$225 and \$215.
For each of the following, state answers to the nearest whole number.
- What is the mean or average cost for this type of cake?
 - What is the percentage change from the lowest quote to the highest quote?
 - If it costs each supplier \$50 in product to make the cake, calculate the percentage profit for each of the four quotes given above.
 - If it takes each supplier on average $5\frac{1}{2}$ hours to make and decorate the cake, what is each person charging per hour, excluding the \$50 product costs?

Using technology

- 6 Imagine that you have started a Facebook cake-making business. To analyse possible profits, set up an Excel spreadsheet as shown below and enter formulas in the shaded cells. Note that this is a simplified analysis and excludes power, gas and equipment costs.

Hint: Format all \$ cells as 'currency' with zero decimal places.
Format profit % cells as 'percentage' with zero decimal places.



	A	B	C	D	E	F	G
1	CELEBRATION CAKES						
2	Cakes (30 serves, decorated)	Product costs in \$	Selling price in \$	Profit in \$	Profit %	Prep time in hours	Hourly rate
3	Birthday - caramel mud	\$35	\$105			3.25	
4	Birthday - choc fudge mud	\$38	\$112			3	
5	Birthday - choc Jaffa	\$35	\$108			3.5	
6	Birthday - child's theme	\$58	\$295			5.5	
7	21st Birthday - 4 tiers cupcakes	\$52	\$220			4	
8	Valentine's Day - red velvet choc	\$36	\$140			3	
9	Wedding - 2 tiers 70 serves	\$85	\$360			6	
10	Wedding - 3 tiers 120 serves	\$120	\$545			9	

- How much profit would be made from selling 2 Valentine's Day cakes and 3 choc Jaffa birthday cakes?
- List, in ascending order, the 3 cakes that bring the lowest percentage profit.
- List, in descending order, the 3 cakes that pay the highest hourly rates.
- Suggest a reason why the cakes in **c** cost the customer more in hourly rates.



Saving for a holiday

Sally is an accounts clerk earning a salary of \$70 348. She plans to save 20% of her fortnightly after tax take home pay, for any extra expenses and to put towards a holiday. In fact, Sally is trying to save for an overseas holiday in 12 months and she estimates she will need \$12 000 for her planned itinerary.

To reach her goal she decides to get a second job working at her local late night supermarket. They offer her three 2½ hour shifts a week paying \$25 an hour. She plans to work here for a total of 20 weeks, thinking that this will give her enough for her trip.

Present a report for the following tasks and ensure that you show clear mathematical workings and explanations where appropriate. Give answers to the nearest cent.

Preliminary task

- At her job at the supermarket, how much does Sally earn per shift?
- How much would she earn per week at the supermarket?
- Over the 20 weeks, calculate Sally's total gross income from the supermarket.
- As an accounts clerk, Sally earns a salary. What is the gross fortnightly income Sally earns from this job?
- What is her total annual taxable income from both jobs, assuming she only works for the 20 weeks at the supermarket?

Modelling task

- The problem is to determine if Sally has saved enough to afford to go on her trip after tax. Write down all relevant information that will help you solve this problem.

- The firm that Sally works for as an accounts clerk take out income tax from her fortnightly pay on her behalf, they do this by using her salary and finding the tax owed by using the current personal income tax table found on the ATO website.
By using the personal income tax table below, calculate the annual tax that the firm deducts from Sally's pay.

Taxable income	Tax on this income
0 – \$18,200	Nil
\$18,201 – \$37,000	19c for each \$1 over \$18,200
\$37,001 – \$90,000	\$3,572 plus 32.5c for each \$1 over \$37,000
\$90,001 – \$180,000	\$20,797 plus 37c for each \$1 over \$90,000
\$180,001 and over	\$54,097 plus 45c for each \$1 over \$180,000

The above rates do not include the Medicare levy of 2%.

- Calculate the fortnightly net pay (take home pay) that Sally receives from her firm.
- Sally aims to save 20% of her take home pay from her firm each fortnight. How much will Sally have saved at the end of 12 months?
- By considering her total taxable income from both jobs, calculate her total income tax liability for the year.
- Hence, calculate Sally's annual net income from her second job.
- Calculate her total tax liability, by including the Medicare levy of 2%.

Evaluate
and
verify

h When Sally takes in account all her finances and tax, will she have enough left from her savings to take her proposed trip?

Communicate

i Summarise your findings and make a recommendation about Sally's savings and proposed trip at the end of the year.

Extension questions

- a** What percentage pay rise is needed from her firm for Sally to no longer need her second job?
- b** Investigate what happens to Sally's tax liability from her salary from her firm if she has allowable tax deductions of:
- i** \$2000
 - ii** \$4000



1 The answers to the clues are hidden in the wordfind. Can you find all 16 words?

S	A	G	R	O	S	S	W	H	K	L	O	M
A	P	E	R	C	E	N	T	A	G	E	C	O
L	A	R	C	O	M	M	I	S	S	I	O	N
A	S	E	R	V	I	N	T	E	R	E	S	T
R	T	Y	H	E	T	S	L	O	S	S	T	H
Y	E	F	O	R	T	N	I	G	H	T	I	L
W	S	M	O	T	A	X	A	T	I	O	N	Y
E	I	O	L	I	D	I	D	N	P	Y	I	E
K	M	N	Q	M	O	N	T	R	N	I	S	C
E	P	Y	U	E	D	I	S	C	O	U	N	T
M	L	R	E	P	A	Y	M	E	N	T	A	H
D	E	D	U	C	T	I	O	N	S	I	X	L

- | | |
|---|---|
| a A fixed annual income | b A percentage of the value of goods sold, which you earn as an income |
| c Working longer than normal working hours | d Money from your income given to the government |
| e Two weeks | f The total of all income |
| g Money taken from total pay | h Yearly |
| i 12 times a year | j Flat-rate interest |
| k Meaning 'out of 100' | l Money given to repay a loan |
| m Money earned on an investment | n An item offered for a sale price has had this happen |
| o The original price of an item | p You incur this when you sell an item for less than you paid for it |

2 Find out the four classical elements of the world by answering the following simple interest problems. Match the letter beside each question to its corresponding answer in each grid.

E = \$600 at 6% p.a. for 1 year	H = \$796 at 5% p.a. for 4 months
R = \$12 500 at $6\frac{1}{4}\%$ p.a. for 2 years	A = \$7000 at 5% p.a. for 3 years
I = \$1000 at 1% p.a. for 100 years	F = \$576.50 at 19% p.a. for 18 months
W = \$36 000 at 2% p.a. for 5 years	T = \$550 at 10% p.a. for 6 months

\$36	\$1050	\$1562.50	\$27.50	\$13.27

\$1050	\$1000	\$1562.50

\$164.30	\$1000	\$1562.50	\$36

\$3600	\$1050	\$27.50	\$36	\$1562.50

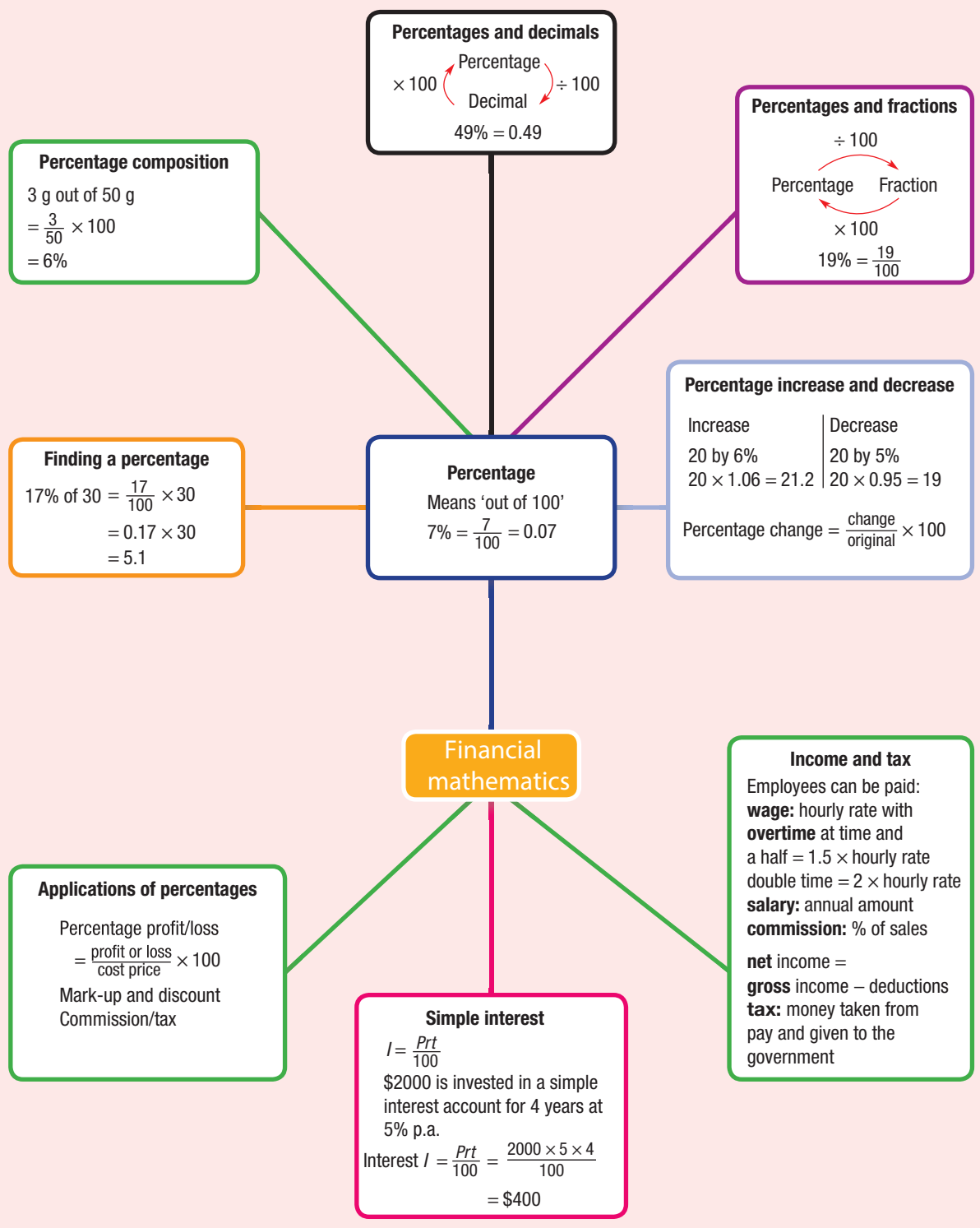

Chapter checklist

A version of this checklist that you can print out and complete can be downloaded from your Interactive Textbook.

2A	<p>1 I can convert between percentages and fractions. e.g. Write</p> <p>a $\frac{7}{40}$ as a percentage b 17.5% as a fraction</p>	✓
2A	<p>2 I can convert between percentages and decimals. e.g. Write</p> <p>a 0.3 as a percentage b 72% as a decimal</p>	
2A	<p>3 I can write a quantity as a percentage. e.g. Write 27 cm out of 1.8 m as a percentage.</p>	
2B	<p>4 I can find a percentage of a quantity. e.g. Find 35% of \$75</p>	
2B	<p>5 I can find the original amount from a percentage. e.g. Determine the original amount if 12% of the amount is \$72</p>	
2C	<p>6 I can increase and decrease by a percentage. e.g. a Increase \$80 by 12% b Decrease \$40 by 8%</p>	
2C	<p>7 I can find a percentage change. e.g. The price of a gym membership increased from \$320 to \$370. Find the percentage increase correct to one decimal place.</p>	
2C	<p>8 I can find the original amount after an increase or decrease. e.g. A decrease of 22% reduced the population of a town to 1014. What was the original population of the town?</p>	
2D	<p>9 I can calculate the selling price from a mark-up or discount. e.g. A store marks up all white goods by 20%. If the cost price of a fridge is \$1100, what will be its selling price?</p>	
2D	<p>10 I can determine percentage profit. e.g. A stall holder makes candles for \$8 and sells them for \$13. Find the profit and express this profit as a percentage of the cost price.</p>	
2D	<p>11 I can calculate the original price before discount. e.g. A department store discounts all Christmas trees by 15%. If the sale price of a tree was \$106.25, what was the original price?</p>	
2E	<p>12 I can compare wages and salaries. e.g. Tony has an annual salary of \$88 000 and Jodie earns \$72 per hour. Calculate</p> <p>a Tony's hourly rate of pay if he works a 38-hour week b Jodie's yearly income if she works on average 22 hours per week.</p>	



		✓
2E	<p>13 I can calculate overtime. e.g. Calculate Julian's weekly wage for a week where he works 12 hours at his normal hourly rate of \$28, 4 hours at time and a half and 3 hours at double time.</p>	
2E	<p>14 I can calculate commission. e.g. A salesperson is paid a retainer of \$2200 per month and receives an 8% commission on sales. If one month he makes sales worth \$10 400, calculate his earnings for that month.</p>	
2F	<p>15 I can calculate net income. e.g. Danielle has an annual salary of \$64 800. She has monthly tax deductions on her payslip of \$1296. Calculate her net income each month.</p>	
2F	<p>16 I can calculate net income using income tax rates. e.g. Anna has an annual salary of \$78 000 and a taxation rate of 26% with the first \$18 200 tax free. Calculate Anna's net income for the year.</p>	
2F	<p>17 I can use the tax table to calculate income tax. e.g. Use the tax table from Example 18 to find the income tax for an income of \$90 000.</p>	
2G	<p>18 I can use the simple interest formula and find the final balance. e.g. Calculate the simple interest earned if the principal is \$4000, the rate is 3% p.a. and the time is 4 years. Hence, what is the amount at the end of the 4 years?</p>	
2G	<p>19 I can work with simple interest using other time periods. e.g. Calculate the simple interest on \$6000 invested at $4\frac{1}{2}\%$ p.a. for 42 months.</p>	
2H	<p>20 I can determine the investment period or interest rate for simple interest. e.g. Joshua invests \$3500 at 6% p.a. simple interest, for a period of time, to produce \$315 interest. For how long did he invest the money?</p>	
2H	<p>21 I can calculate repayments. e.g. Syd takes out a loan to purchase a yacht. The loan is for \$32 000 at 8% p.a. simple interest if the loan is repaid in equal monthly instalments over 4 years. Calculate the interest charged on the loan and hence the total amount owing and the size of the required monthly repayments.</p>	

Short-answer questions

- 2A 1 Copy and complete the table shown.

Decimal	Fraction	Percentage
0.6		
	$\frac{1}{3}$	
		$3\frac{1}{4}\%$
	$\frac{3}{4}$	
1.2		
		200%

- 2B 2 Find:



- a 25% of \$310
b 110% of 1.5

- 2B 3 Determine the original amount if:



- a 20% of the amount is 30.
b 72% of the amount is 18.

- 2C 4 a Increase 45 by 60%.



- b Decrease 1.8 by 35%.
c Find the percentage change if \$150 is reduced by \$30.

- 2C 5 The mass of a cat increased by 12% to 14 kg over a 12 month period. What was its previous mass?



- 2D 6 Determine the discount given on a \$15 000 car if it is discounted by 12%.



- 2D 7 A couch at a cost price of \$3500 is to be marked up by 25%. Find the selling price.



- 2D 8 The cost price of an article is \$150. If it is sold for \$175:



- a determine the profit made
b express the profit as a percentage of the cost price.

- 2E 9 Determine the hourly rate of pay for each of the following cases:



- a a person with an annual salary of \$76 076 working a 38-hour week
b a person who earns \$429 working 18 hours at the hourly rate and 8 hours at time and a half.

- 2F 10 Jo's monthly income is \$5270 however 20% of this is paid straight to the government in taxes. What is Jo's net yearly income?



- 2G 11 Find the simple interest earned on \$1500 at 7% p.a. for 5 years.



- 2H** **12** Bill invests \$6000 at 4% simple interest, for a period of time, to produce \$720. For how long did he invest the money?



- 2F** **13** Use the tax table below to find the income tax payable on an income of \$78 000.



Taxable income	Tax on this income
\$0 – \$18 200	Nil
\$18 201 – \$37 000	19c for each \$1 over \$18 200
\$37 001 – \$80 000	\$3572 plus 32.5c for each \$1 over \$37 000
\$80 001 – \$180 000	\$17 547 plus 37c for each \$1 over \$80 000
\$180 001+	\$54 547 plus 45c for each \$1 over \$180 000*

* Does not include the Medicare levy (2% of taxable income).

Multiple-choice questions

- 2A** **1** 2.8% as a decimal is:
A 2.8 **B** 0.28 **C** 0.028 **D** 0.0028 **E** 280

- 2A** **2** What percentage of \$2 is 50 cents?
A 4% **B** 40% **C** 25% **D** $2\frac{1}{2}\%$ **E** 400%

- 2A** **3** $12\frac{1}{2}\%$ as a simple fraction is:
A $\frac{12}{100}$ **B** $\frac{1}{8}$ **C** $\frac{3}{25}$ **D** 0.125 **E** 12.5

- 2B** **4** $33\frac{1}{3}\%$ of \$660 is the same as:
A $\$660 \div 2$ **B** $\$660 \times 0.3$ **C** $\$660 \times 0.03$ **D** $\$660 \div 3$ **E** $\$660 \div \frac{1}{3}$

- 2B** **5** 15% of \$1600 is equal to:
A 24 **B** 150 **C** \$240 **D** \$24 **E** 240



- 2B** **6** If 110% of a number is 528, then the number is:
A 475.2 **B** 52.8 **C** 480 **D** 580.8 **E** 475



- 2C** **7** 9670 increased by 12% becomes:
A 9682 **B** 9658 **C** 10830.4 **D** 1160.4 **E** 8509.6



- 2E** **8** Jane is paid a wage of \$27.80 per hour. She works 12 hours at this rate during a week, plus 4 hours on a public holiday where she gets paid at time and half. Her earnings in the week are:
A \$500.40 **B** \$444.80 **C** \$556 **D** \$667.20 **E** \$278



- 2E** **9** Simon earns a weekly retainer of \$370 and 12% commission of any sales he makes. If he makes \$2700 worth of sales in a particular week, he will earn:
A \$595 **B** \$652 **C** \$694 **D** \$738.40 **E** \$649.60



- 2G/2H** **10** \$1200 is invested with a simple interest rate of 10% for two years. The total balance at the end of the two years is:
A \$252 **B** \$1452 **C** \$1450 **D** \$240 **E** \$1440



Extended-response questions



- 1 Pauline buys a debutante dress at cost price from her friend Tila. Pauline paid \$420 for the dress which is normally marked up by 55%.
- How much did she save?
 - What is the normal selling price of the dress?
 - If Tila gets a commission of 15%:
 - how much commission did she get?
 - how much commission did Tila lose by selling the dress at cost price rather than the normal selling price?



- 2 Adam starts a new job and works a 38-hour week for a wage of \$975.84.
- Calculate his hourly rate of pay.
 - If overtime is calculated at time and a half, what is Adam's overtime rate?
 - How much does Adam earn for 4 hours of overtime work?
 - How many hours of overtime did Adam work in a week if his wage for that week was \$1226.22?
 - If Adam usually works the amount of overtime in part **d** in the 52 weeks of the year he works, and he pays 27% of his pay in tax, what is his net annual income?
 - If Adam invests 10% of his net income in an account earning 8% p.a. simple interest for 18 months, how much extra income will he have earned?



Chapter 3

Expressions and equations

Essential mathematics: why skills with algebraic expressions and formulas are important

Skills using algebraic formulas and solving algebraic equations are important in agriculture, animal management, manufacturing, technology, business, computer programming, finance, science (including sports science), and widely applied in the food industry, trades and other professional occupations.

- Training for a scuba diving certificate includes solving the equations that show with increasing depth the water pressure increases but the volume of air in a diver's lungs decreases. When the diver is ascending, the air in the lungs expands.
- Vets use algebraic formulas relating drug dosage to an animal's weight. Vets calculate a horse's weight in kg using the formula: $\text{weight} = \frac{G^2L}{11880}$, where G is the girth in cm and L is body length in cm.
- Computer programmers often need to solve linear equations, such as when writing software code for various applications; developing websites; troubleshooting network problems; calculating data upload times; and adjusting security settings.

In this chapter

- 3A Algebraic expressions
(Consolidating)
- 3B Adding and subtracting algebraic expressions
(Consolidating)
- 3C Multiplying and dividing algebraic expressions
(Consolidating)
- 3D Expanding algebraic expressions
- 3E Solving linear equations
(Consolidating)
- 3F Solving linear equations involving fractions
- 3G Solving equations with brackets
- 3H Solving equations with pronumerals on both sides
- 3I Solving word problems ★
- 3J Using formulas ★

Australian Curriculum

NUMBER AND ALGEBRA Patterns and algebra

Apply the distributive law to the expansion of algebraic expressions, including binomials, and collect like terms where appropriate (ACMNA213)

Linear and non-linear relationships

Sketch linear graphs using the coordinates of two points and solve linear equations (ACMNA215)

© Australian Curriculum, Assessment and Reporting Authority (ACARA)

Online resources

A host of additional online resources are included as part of your Interactive Textbook, including HOTmaths content, video demonstrations of all worked examples, auto-marked quizzes and much more.

1 Write in simplified form.

a $3 \times x$

c $2 \times 5 \times x$

b $4 \times a \times b$

d $3 \times b \times 7$

2 If $x = 3$, find the value of:

a $x + 5$

c $4x$

e $2x + 3$

b $10 - x$

d $\frac{18}{x}$

f $2(x + 4)$

3 Write algebraic expressions for:

a 3 more than x

b the product of a and b

c 2 lots of y less 3

d the sum of x and 2, all divided by 3

4 Calculate:

a -6×3

c $-8 \times (-5)$

e $-2 + 5$

g $7 - 11$

b -7×4

d $-1 \times (-3)$

f $-8 + 3$

h $-2 - 6$

5 Simplify by collecting like terms.

a $2x + 5x - 4x$

c $4x - (-4x)$

e $3a + 4a^2 + 7a + 5a^2$

b $7y + 5 - y$

d $3x + 12y - 3x + 5y$

f $3xy - 4y + 2yx - 3y$

6 Simplify the following.

a $3 \times 2a$

c $\frac{8b}{2}$

b $7x \times (-3y)$

d $\frac{9mn}{6n}$

7 Expand the following.

a $2(x + 3)$

b $3(a - 5)$

c $4(2x + 1)$

8 Evaluate the following if $a = 3$ and $b = -2$.

a $2a - 5$

c $\frac{9}{a} - b$

b $ab + 4$

d $2a(b + 1)$

9 To which of the following equations is $x = 4$ a solution?

a $2x + 3 = 9$

c $\frac{2x + 1}{3} = 3$

b $\frac{x}{2} + 3 = 5$

d $5 - 2x = -1$

10 Find the value of a that makes the following true.

a $a + 4 = 13$

c $2a + 1 = 9$

b $a - 3 = 7$

d $\frac{a - 1}{4} = 5$

3A Algebraic expressions

CONSOLIDATING

Learning intentions

- To review the terms associated with algebraic expressions
- To be able to identify terms, coefficients and constant terms in expressions
- To know the notation for multiplication and division involving pronumerals
- To be able to convert words and word problems into algebraic expressions
- To be able to substitute into expressions and evaluate

Key vocabulary: pronumeral, variable, expression, term, coefficient, constant term, substitution, evaluate

Algebra is central to the study of mathematics and is commonly used to solve problems in many everyday situations and in more complex problems. Algebra involves working with unknown values in maths. Pronumerals (or variables) are used to represent these unknown values.

→ Lesson starter: What does the letter mean?

Consider the following situations and how they could be written as algebraic expressions.

- Fidel has 7 marbles and Jack has an unknown number of marbles, which we will call m . They then each get 4 more marbles.
 - How many marbles does Fidel have now?
 - What mathematical operation (+, −, ×, ÷) did you use to answer part **a**?
 - Using the same operation, how could you describe how many marbles Jack has now?
- Fidel can buy a chocolate bar for \$2. Jack can buy a different chocolate bar but he will pay an unknown amount for it. We'll call the amount Jack pays p (dollars).
 - If Fidel buys 3 chocolate bars, how much will he pay?
 - If Fidel buys 10 chocolate bars, how much will he pay?
 - What mathematical operation did you use to answer parts **a** and **b**?
 - Using the same operation, how could you write how much Jack will pay for 5 chocolate bars?

Key ideas

- In algebra, letters are used to represent numbers. These letters are called **pronomerals** (sometimes written pro-numerals).
 - Pronumerals can also be called **variables** if they can take a range of possible values.
- In algebra, the multiplication and division signs are generally not shown.
For example: $3 \times x$ is written as $3x$ and $x \div 4$ is written as $\frac{x}{4}$.
- An **expression** is a combination of numbers and pronumerals connected by the four operations +, −, × and ÷. Brackets can also be used.
For example: $5x + 4y - 1$ and $3(x + 2) - \frac{y}{5}$.
- A **term** is a combination of numbers and pronumerals connected with only multiplication and division. Terms are separated with the operations + and −. For example: $5x + \frac{7}{y}$ is a two-term expression with $5x$ and $\frac{7}{y}$ as the two terms.

3A

- **Coefficients** are the numbers being multiplied by pronumerals.

$$3 \text{ is the Coefficient of } x \quad -2 \text{ is the Coefficient of } xy$$

$$\textcircled{3}x \quad +7y \quad \textcircled{-2}xy \quad +5 \quad \text{--- } 5 \text{ is a constant term}$$

This expression has 4 terms

- **Constant terms** consist of a number only.
For example: -2 in $x^2 + 4x - 2$ (The sign must be included.)
- **Substitution** is the process of replacing a pronumeral with its numeric value.
Expressions can be evaluated by substituting a number for a pronumeral.
For example: if $a = 2$ then $a + 6 = 2 + 6 = 8$
- Order of operations should be followed when evaluating expressions:
 - 1 Brackets
 - 2 Powers
 - 3 Multiplication and division
 - 4 Addition and subtraction

Exercise 3A

Understanding

1–4

4

- 1 Use the words from the list below to complete the following.

expression, coefficient, constant term, terms, pronumeral

- a $3x - 2y + 7$ is an example of an algebraic _____.
- b In $2a + b - 3$, -3 is the _____.
- c In $4m + 3$, m is called a _____.
- d In $3 - 2y + 4z$, 4 is the _____ of z .
- e In the expression $3s + 7t$, $3s$ and $7t$ are the _____.

- 2 Express in simplified form without the \times or \div symbols.

- a $7 \times y$ b $-2 \times x$ c $a \times b$ d $y \div 2$ e $x \div y$ f $2 \div a$

- 3 Substitute $x = 2$ into the following and evaluate.

- a $x + 3$ b $10 - x$ c $7x$ d $\frac{8}{x}$

Hint: Substitute means to replace the pronumeral with the given numeral



- 4 State, yes or no, if 2 is the coefficient of x in the following.

- a $2x + 7$ b $y - 2x$ c $3xy - 4y + 2x$ d $\frac{x}{2} - 3$

Fluency

5, 6, 7–8(½)

5, 6, 7–8(½)



Example 1 Identifying parts of algebraic expressions

Consider the expression $5a + 2ab + 7 - 4b$.

a How many terms are in the expression?

b State the coefficient of:

i a

ii b

c What is the constant term?

Solution**Explanation**

a There are 4 terms.

The terms in the expression are separated by + or –.

b i 5 is the coefficient of a .

$5a$ is $5 \times a$; 5 is the number being multiplied by a .

ii –4 is the coefficient of b .

$-4b$ is $-4 \times b$; the negative sign is included.

c 7 is the constant term.

7 is the number with no pronumeral part.

Now you try

Consider the expression $3ab + 5 - 2a + 6b$.

a How many terms are in the expression?

b State the coefficient of:

i a

ii b

c What is the constant term?

5 Complete each of the parts **i–iii** for the algebraic expressions below.

i How many terms are in the expression?

ii What is the coefficient of y ?

iii What is the constant term?

a $5x + 2y + 3$

b $2x - 3y$

c $3xy + 7y - 4$

d $2x^2 - 1 + 4x + \frac{y}{2}$

Hint: Remember: the coefficient of a pronumeral includes the sign before it; in $3 - 2x$, -2 is the coefficient of x .



Example 2 Writing algebraic expressions for word problems

Write an algebraic expression for the following.

a The number of tickets needed for 3 boys and r girls

b The cost in dollars of P pies at \$3 each

c The amount for each person if a \$300 prize is shared equally among m friends

Solution**Explanation**

a $3 + r$

3 tickets plus the number of girls, r .

b $\$3P$

2 pies would cost $\$3 \times 2 = \6 . The cost is $3 \times$ the number of pies, so P pies costs $\$3 \times P = \$3P$

c $\frac{\$300}{m}$

\$300 shared between 3 people is \$300 divided into 3 parts, so \$300 divided into m parts is $\$300 \div m = \frac{\$300}{m}$.

Continued on next page

3A

Now you try

Write an algebraic expression for the following.

- a The number of tickets required for 5 children and g adults
- b The cost of 4 tickets at $\$x$ each
- c The amount for each child if 600 mL of juice is shared equally among y children

6 Write an algebraic expression for the following.

- a The number of tickets required for:
 - i 4 boys and r girls
 - ii t boys and 2 girls
 - iii x boys, y girls and z adults
- b The cost in dollars of:
 - i P pies at $\$6$ each
 - ii 10 pies at $\$n$ each
 - iii D drinks at $\$2$ each
 - iv P pies at $\$5$ and D drinks at $\$2$
- c The number of grams of lollies for one child if 500 g of lollies is shared equally among C children.

Hint: For part b i:

1 pie costs $\$6 \times 1 = \6
 2 pies cost $\$6 \times 2 = \12
 5 pies cost $\$6 \times 5 = \30
 P pies cost ...



Example 3 Converting words to expressions

Write an algebraic expression for the following.

- a Five less than x
- b Three more than twice x
- c The sum of a and b is divided by 4
- d The square of the sum of x and y

Solution

Explanation

- | | |
|-------------------|---|
| a $x - 5$ | 5 below x is 5 subtracted from x . |
| b $2x + 3$ | Twice x is $2 \times x$, then add 3. |
| c $\frac{a+b}{4}$ | The sum of a and b is done first ($a + b$) and the result divided by 4. |
| d $(x + y)^2$ | The sum of x and y is done first and then the result is squared (recall that the square of a is $a^2 = a \times a$). |

Now you try

Write an algebraic expression for the following.

- a Seven more than y
- b Six less than twice x
- c The sum of m and n is divided by 3
- d The square root of the sum of a and b

7 Write an algebraic expression for each of the following.

- a The sum of 2 and x
- b The sum of ab and y
- c 5 less than x
- d 7 subtracted from $2y$
- e The product of x and 3
- f Three times the value of p
- g Four more than twice x
- h The sum of x and y is divided by 5
- i 10 less than the product of 4 and x
- j 3 lots of x subtracted from 1
- k The sum of 3 and y is divided by 2
- l Half of 1 more than x
- m The square of the sum of m and n
- n The sum of the squares of m and n

Hint: Sum is +
 Product is \times
 Twice is $\times 2$
 Square of x is x^2





Example 4 Substituting values into expressions

Evaluate these expressions if $a = 5$, $b = 6$ and $c = -3$.

a $3a + b$

b $2a - (b + c)$

c $a^2 - bc$

Solution

Explanation

$$\begin{aligned} \mathbf{a} \quad 3a + b &= 3 \times 5 + 6 \\ &= 15 + 6 \\ &= 21 \end{aligned}$$

Substitute the value 5 for a and the value 6 for b . Recall $3a = 3 \times a$.

$$\begin{aligned} \mathbf{b} \quad 2a - (b + c) &= 2 \times 5 - (6 + (-3)) \\ &= 10 - 3 \\ &= 7 \end{aligned}$$

Substitute the values for a , b and c . Then apply order of operations, with brackets evaluated first, before moving onto multiplication and division, then addition and subtraction.
 $6 + (-3) = 6 - 3 = 3$

$$\begin{aligned} \mathbf{c} \quad a^2 - bc &= (5)^2 - 6 \times (-3) \\ &= 25 - (-18) \\ &= 25 + 18 \\ &= 43 \end{aligned}$$

Evaluate powers before the other operations:
 $5^2 = 5 \times 5$.
A positive (6) times a negative (-3) gives a negative (-18).
Subtracting a negative means to add.

Now you try

Evaluate these expressions if $a = 4$, $b = -2$ and $c = 5$.

a $a + 4c$

b $2b - (a + c)$

c $c^2 - ab$

8 Evaluate these expressions if $a = 4$, $b = -3$ and $c = 8$.

a $3a + c$ **b** $ac - 7$ **c** $2c - (a + b)$

d $a^2 - 2c$ **e** $\frac{a+c}{2}$ **f** $b + 2(c - a)$

g $2c - ab$ **h** abc **i** $b - c + a^2$

Hint: When adding or subtracting a negative number:

$$8 + (-3) = 8 - 3 = 5$$

$$8 - (-3) = 8 + 3 = 11$$



Problem-solving and reasoning

9–11

10–13

9 A rectangular garden bed is 12 m long and 5 m wide.

a Find the area of the garden bed.

b The length is increased by x m and the width is decreased by y m. Find the new length and width of the garden.

c One length and one width of the rectangular garden will be lined with paving. Write an expression for the total distance around the garden that will be paved.

Hint: Draw a diagram to help.
Area of a rectangle = $l \times w$



10 Jelena earns $(10 + 8t)$ dollars for each shift that she works, where t is the number of hours worked in the shift.

a How much does Jelena earn if $t = 2$?

b How much does Jelena earn from a 5-hour shift?

c Will she earn \$100 from a 10-hour shift?

d How many whole hours must she work to earn more than \$100?



3A

- 11 The expression for the area of a trapezium is $\frac{1}{2}(a+b)h$, where a , b and h represent the lengths shown.
- Find the area of the trapezium with $a = 5$, $b = 7$ and $h = 3$.
 - A trapezium has $h = 4$ and area 12. If a and b are whole numbers, what possible values can the pronumeral a have?

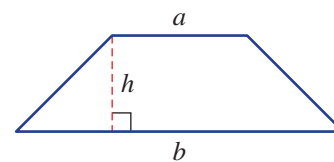

- 12 Christina earns \$ A from selling 20 glasses of lemonade. Write an expression for:
- the cost of one glass of lemonade
 - the cost of three glasses of lemonade
 - the cost of n glasses of lemonade



- 13 For each of these shapes, write an expression for:
- the perimeter
 - the area

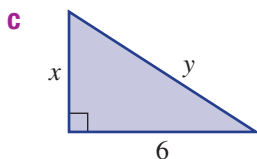
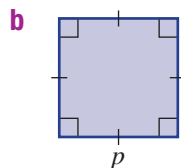
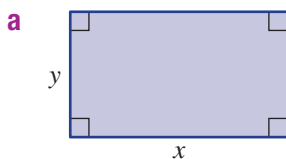

Hint: Perimeter is the distance around the outside of the shape. Area of a rectangle is length \times width. Area of a triangle is $\frac{1}{2} \times$ base \times height.



Should there be brackets?

—

14

- 14 Brackets are used to ensure that the mathematics inside the brackets occurs first.
- By substituting values for x , decide whether the following are the same.
 - $2(x+1)$ and $2x+1$
 - $3+\frac{x}{2}$ and $\frac{3+x}{2}$
 - Write down two different possible expressions that could describe each of the following.
 - 3 lots of x plus 1
 - The sum of 5 and x divided by 3
 - Half of x plus y
 - Write down a clear statement that describes the following expressions.

i $4(x+2)$	ii $3+\frac{x}{2}$	iii $\frac{1}{3}(m+n)$
iv $5x+7$	v $\frac{x+y}{2}$	vi $\frac{1}{2}a+b$

3B Adding and subtracting algebraic expressions

CONSOLIDATING

Learning intentions

- To understand that only like terms can be combined under addition or subtraction
- To be able to identify like terms
- To be able to collect like terms under addition or subtraction

Key vocabulary: like terms, pronumeral, coefficient

Just as $2 + 2 + 2 + 2 = 4 \times 2$, so $x + x + x + x = 4 \times x$ or $4x$. We say that the expression $x + x + x + x$ is simplified to $4x$; i.e. 4 lots of x . Similarly, $3x + 2x = x + x + x + x + x = 5x$ and $4x - 3x = x + x + x + x - (x + x + x) = x$.

All these expressions have like terms and can be simplified to an expression with a smaller number of terms by adding or subtracting their coefficients.



$$x + x + x + x = 4x$$

Lesson starter: Two groups

Place the terms in the following four sets into groups of similar terms on either side of the dividing line. The first set has been started for you.

Set 1	Set 2	Set 3	Set 4
3x 7y 2x 8x y 5x 2y 3x 2y	4ab 2a 5ab 7a ab 6ab 	2 5y 7 1 3y 2y 8 25 	3ab 4a ² b 2ab 10ab 5a ² b 12ab 9a ² b

- Describe how you classified each set into two groups.
- What do the terms in each group have in common?
- Simplify the sum of all the terms in each of the eight groups.

Key ideas

- $4x$ means $4 \times x$ or $x + x + x + x$.
 - x means $1 \times x$ but we leave off the 1 and express it simply as x .
- Like terms** have the same pronumerals and powers.
For example: $5x$ and $7x$ are like terms
 $3ab$ and $-8ab$ are like terms
 - Since $a \times b = b \times a$ then ab and ba are also like terms
- The pronumeral part of a term is often written in alphabetical order; e.g. xy rather than yx .
- Like terms can be collected to form a single term by adding or subtracting the coefficients.
For example: $4x + 7x = 11x$
 $10ab - 2ab = 8ab$
- Unlike terms do not have the same pronumeral factors.
For example: $5x$, x^2 , xy , $2xy^2$ and 3 are all unlike terms.

Exercise 3B

Understanding

1–3

3

- 1 Fill in the missing word or number.
- $4a$ and $7a$ are an example of _____ terms.
 - To add like terms, we add the _____.
 - Like terms have the same _____ and powers.
 - The coefficient of y in $2x + y$ is _____.
- 2 Decide whether the following pairs of terms are like terms (Yes or No).
- | | | |
|--------------------------|--------------------------|------------------------------|
| a $4ab$ and $3ab$ | b $2x$ and $7xy$ | c 5 and $4m$ |
| d $7yz$ and $-yz$ | e $2mn$ and $9nm$ | f $3x^2y$ and $7xy^2$ |
- 3 Which of the following represent the same expression as $w - x + y - z$?
- | | |
|--------------------------|---------------------------|
| a $w - z + y - x$ | b $w - y + x - z$ |
| c $y + w - z - x$ | d $-x + w - z + y$ |
| e $y - w - x + z$ | f $y - z - x + w$ |

Hint: Like terms must have exactly the same pronumerals and powers.



Hint: Make sure the correct pronumerals are being added or subtracted.



Fluency

4, 5–6(½)

4–6(½)

Example 5 Identifying like terms

Choose the pair(s) of like terms from the following sets.

a $3x, 3, 4xy, 5x, y$

b $4b, 4bc, b, 2abc, -7bc, 2bc^2$

Solution

Explanation

a $3x$ and $5x$ are like terms.
The rest are not.

$3x$ and $5x$ have the same pronumeral; i.e. x .

b $4b$ and b are like terms.
 $4bc$ and $-7bc$ are like terms.

$4b$ and b have the same pronumeral.
 $4bc$ and $-7bc$ have the same pronumerals.
 $2bc^2$ does not, due to the power of 2.
All other terms do not have the same pronumerals and powers.

Now you try

Choose the pair(s) of like terms from the following sets.

a $5m, 3mn, 7, n, 2m$

b $7y, 4xz, 5xy^2, -2xyz, zx, -y$

- 4 Choose the pair(s) of like terms from the following sets.
- | | |
|-----------------------------------|---|
| a $4y, 5, 3xy, 2y, 7xy$ | b $3x, 3y, 3, xy, 7x$ |
| c $7ab, 2a, -3ab, b^2, 5a$ | d $2a^2, 4a, 3ab, a, -3a^2$ |
| e $2xy, 3x^2y, -5x, 7yx^2$ | f $5ab^2, 3ab, 2b^2, 4ab^2, 7ba$ |

Hint: st and ts are like terms since $s \times t = t \times s$.



**Example 6 Collecting like terms**

Simplify the following by collecting like terms.

a $4a + 7a$

b $3x + 4 - 2x$

Solution**Explanation**

a $4a + 7a = 11a$

Since $4a$ and $7a$ are like terms they can be simplified to one term by adding their coefficients: $4 + 7 = 11$.

b $3x + 4 - 2x = 3x - 2x + 4$
 $= x + 4$

Collect like terms ($3x$ and $-2x$). The sign belongs to the term that follows. Combine their coefficients: $3 - 2 = 1$. Recall that $1x$ is written as x .**Now you try**

Simplify the following by collecting like terms.

a $5t + 3t$

b $9y + 3 - 5y$

5 Simplify the following by collecting like terms.

a $3a + 7a$

b $4n + 3n$

c $12y - 4y$

d $5x + 2x + 4x$

e $6ab - 2ab$

f $7mn + 2mn - mn$

g $4y + 3y + 8$

h $7x + 5 - 4x$

i $5m + 2 - m$

j $5ab + 3a + 7ab$

k $6xy + xy + 4y$

l $5bc - 4 - 2bc$

Hint: In order to add or subtract coefficients, the terms must be like terms.

**Example 7 Combining like terms**

Simplify the following by collecting like terms.

a $3x + 2y + 4x + 7y$

b $3xy + 4x + xy - 6x$

c $8ab^2 - 9ab - 5ab^2 + 3ba$

Solution**Explanation**

a $3x + 2y + 4x + 7y = 3x + 4x + 2y + 7y$
 $= 7x + 9y$

Collect like terms ($3x$ and $4x$ and $2y$ and $7y$) and combine their coefficients: $3 + 4 = 7$ and $2 + 7 = 9$.

b $3xy + 4x + xy - 6x = 3xy + xy + 4x - 6x$
 $= 4xy - 2x$

Collect the like terms ($3xy$ and xy and $4x$ and $-6x$). Combine their coefficients (recall $xy = 1xy$): $3 + 1 = 4$ and $4 - 6 = -2$

c $8ab^2 - 9ab - 5ab^2 + 3ba$
 $= 8ab^2 - 5ab^2 - 9ab + 3ab$
 $= 3ab^2 - 6ab$

Collect like terms in ab^2 and ab . Remember that $ba = ab$ and the $+$ or $-$ sign belongs to the term that follows; i.e. $-5ab^2$.
Combine coefficients: $8 - 5 = 3$ and $-9 + 3 = -6$.**Now you try**

Simplify the following by collecting like terms.

a $4a + 3b + 2a + 10b$

b $5st + 3s - 2st + s$

c $2x^2y - 5xy + 3x^2y - yx$

3B

6 Simplify the following by collecting like terms.

a $2a + 4b + 3a + 5b$

d $6t + 5 - 2t + 1$

g $4ab + 2a + ab - 3a$

j $5xy^2 - 2xy^2$

m $x^2 - 7x + 3x^2 + 4x$

b $4x + 3y + 2x + 2y$

e $5x + 1 + 6x + 3$

h $3st - 8ts + 2st + 3ts$

k $8m^2n - 6nm^2 + m^2n$

n $a^2b - 4ab + 3a^2b + ba$

c $xy + 8x + 4xy - 4x$

f $3mn + 4 + 4nm - 5$

i $8ac - 6c + 2ac - 3c$

l $2x^2y - 4xy + 5yx^2$

o $10pq^2 - 2qp - 3pq^2 - 6pq$

Problem-solving and reasoning

7, 8

8(1/2), 9, 10

7 A farmer has x pigs and y chickens.

a Write an expression for the total number of heads.

b Write an expression for the total number of legs.



8 Write simplified expressions for the perimeter of the following shapes.

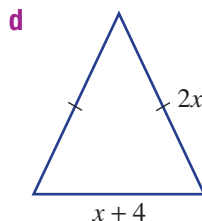
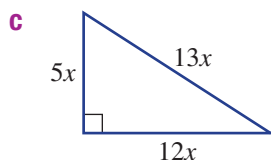
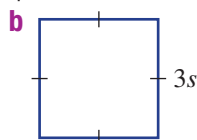
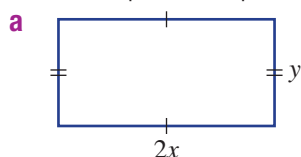

Hint: Sides with matching dash marks are equal in length.

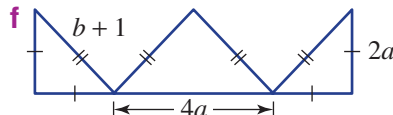
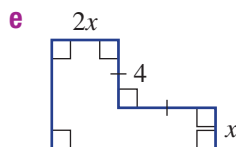
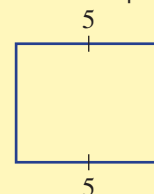

9 A rectangular pool's length is three times its width, x metres. Write an expression for its perimeter.

10 Fill in the missing term to make each of the following correct.

a $11t + 3 - \square = 7t + 3$

b $\square + 3y - 2x = 7x + 3y$

c $3x + 4y - \square + 5y = x + 9y$

d $4a + 7b - \square - 2b = 5b - 3a$

e $3mn - \square + nm + 4n = 4mn - n$

f $2pq + 2p - \square - 5pq = 2p - 7pq$

g $3x^2y - 11xy + 3yx^2 - \square = 6x^2y - 13xy$

h $4b^2 - 3b + 2b^2 + \square = 6b^2$



Around the edge

—

11

11 Consider the shape shown.

a If the unknown sides (?) have length $2b$, what is the perimeter in simplified form?

b If $a = 3$ and $b = 2$ and the perimeter is 23 units, what is the length of the unknown sides?

c If the perimeter is $(5a + 3b)$, what is the length of each unknown side?

d If the perimeter is $(7a + b)$, what is the length of each unknown side?

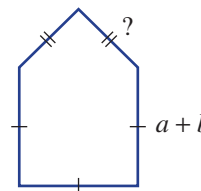

3C Multiplying and dividing algebraic expressions

CONSOLIDATING

Learning intentions

- To understand that order does not matter when multiplying
- To be able to multiply algebraic terms by multiplying coefficients and pronumerals
- To be able to divide algebraic terms by cancelling the highest common factor

Key vocabulary: pronumeral, coefficient, factor, highest common factor

We have seen that $3x + 3x$ can be simplified to $6x$ and that $3x \times 3x$ can also be written as $2 \times 3x$. Thus, $2 \times 3x = 6x$. Also, $4 \times 5a = 4 \times 5 \times a = 20a$. Any two or more terms can be simplified using multiplication; we do not need the terms to be like terms.

A single term such as $2 \times 5 \times x \div 10$ can also be simplified using multiplication and division, so $2 \times 5 \times x \div 10 = \frac{10x}{10} = x$, since $\frac{10}{10}$ simplifies to 1 by cancelling the common factor.

→ Lesson starter: Are they equivalent?

These expressions can be separated into two groups. Group them so that the expressions in each group are equivalent.

$$\begin{array}{cccc} 4x & 2x - y & 6x - x - x & 10x - y - 8x \\ \frac{24x}{6} & y + 2x - y + 2x & 2 \times x - 1 \times y & -y + 2x \\ \frac{1}{2} \times 8x & 2 \times 2x & \frac{8x^2}{2x} & -1 \times y + \frac{2x^2}{x} \end{array}$$

Key ideas

- The symbols for multiplication (\times) and division (\div) are usually not shown in simplified algebraic terms.
For example: $5 \times a \times b = 5ab$ and $-7 \times x \div y^2 = -\frac{7x}{y^2}$
- Order does not matter in multiplication; i.e. $2 \times 3 = 3 \times 2$, $a \times 2 \times b = 2 \times a \times b$.
- Algebraic terms are multiplied by multiplying coefficients with the pronumeral parts.
For example: $4a \times 3b = 4 \times 3 \times a \times b = 12ab$.
- The factors of a number are the set of numbers that divide evenly into it. For example, the **factors** of 6 are 1, 2, 3 and 6.
- When dividing algebraic expressions, common factors can be cancelled. Cancel the highest common factor of the numerals and then the pronumerals.

For example: $\frac{17x}{214} = \frac{x}{2}$, $\frac{28xy1}{312y1} = \frac{2x}{3}$, $\frac{a^2b}{a} = \frac{1\cancel{a} \times a \times b}{1\cancel{a}} = ab$

Exercise 3C

Understanding

1, 2

2

1 Complete the simplified form of the following.

a $7 \times x \times y = \square$

b $3 \times 2 \times m = \square m$

c $4 \times x \times 5 = \square$

d $a \times a = a^{\square}$

2 Answer true (T) or false (F) to the following statements.

a $2 \times x \times 3 = 2 \times 3 \times x$

b $7a \times 3b = 7 \times 3 \times a \times b$

c $4x \times 5xy = 4 \times 5 \times x \times y$

d $\frac{8x}{16} = 2x$

e $5a^2 \div (10a) = \frac{10a}{5a^2}$

f $\frac{3xy^2}{y} = 3xy$

Hint: Simplify by cancelling the highest common factor of the numerator and denominator:

$$\frac{6}{10} = \frac{\cancel{2}_1 \times 3}{\cancel{2}_1 \times 5} = \frac{3}{5}$$



Fluency

3–5(½)

3–5(½)



Example 8 Multiplying algebraic terms

Simplify the following.

a $3 \times 2b$

b $-2a \times 3b$

Solution

Explanation

a $3 \times 2b = 3 \times 2 \times b$
 $= 6b$

Multiply the coefficients.

b $-2a \times 3b = -2 \times 3 \times a \times b$
 $= -6ab$

Recall that multiplication can occur in any order; i.e. $2 \times 3 \times 4 = 2 \times 4 \times 3$ etc. Multiply the coefficients and simplify.

Now you try

Simplify the following.

a $4 \times 5x$

b $-3m \times 6p$

3 Simplify the following.

a $5 \times 2m$

b $2 \times 6b$

c $3 \times 5p$

d $3x \times 2$

e $3p \times 6r$

f $4m \times 4n$

g $-2x \times 7y$

h $5m \times (-3n)$

i $-4c \times 3d$

j $2a \times 3b \times 5$

k $-4r \times 3 \times 2s$

l $5j \times (-4) \times 2k$



Example 9 Dividing algebraic terms

Simplify the following.

a $\frac{4x}{8}$

b $10ab \div (15b)$

Solution

$$\text{a } \frac{14x}{28} = \frac{x}{2}$$

$$\begin{aligned} \text{b } 10ab \div (15b) &= \frac{10ab}{15b} \\ &= \frac{2\cancel{10} \times a \times \cancel{b}^1}{3\cancel{15} \times \cancel{b}^1} \\ &= \frac{2a}{3} \end{aligned}$$

Explanation

Deal with numerals and pronumerals separately, cancelling any common factors.
The highest common factor of 4 and 8 is 4.

Write division as a fraction first. Write numerator and denominator as a product and cancel the common factors 5 and b .

Now you try

Simplify the following.

$$\text{a } \frac{9x}{27}$$

$$\text{b } 18pq \div (4p)$$

4 Simplify the following by cancelling.

$$\text{a } \frac{8b}{2}$$

$$\text{b } \frac{2a}{6}$$

$$\text{c } \frac{4ab}{6}$$

$$\text{d } \frac{3mn}{6n}$$

$$\text{e } \frac{5xy}{20y}$$

$$\text{f } \frac{10st}{6t}$$

$$\text{g } \frac{3xy}{xy}$$

$$\text{h } \frac{27pq}{6p}$$

$$\text{i } 2x \div 4$$

$$\text{j } 12ab \div (2a)$$

$$\text{k } 7mn \div (3n)$$

$$\text{l } 8y \div (20xy)$$

Hint: Make sure they are in fraction form before cancelling;
e.g. $2x \div 4 = \frac{2x}{4}$.



Example 10 Multiplying and dividing with squared pronumerals

Simplify the following.

$$\text{a } 6x \times 5xy$$

$$\text{b } \frac{12a^2b}{3ab}$$

Solution

$$\begin{aligned} \text{a } 6x \times 5xy &= 6 \times 5 \times x \times x \times y \\ &= 30x^2y \end{aligned}$$

$$\begin{aligned} \text{b } \frac{12a^2b}{3ab} &= \frac{4\cancel{12} \times \cancel{a}^2 \times a \times \cancel{b}^1}{\cancel{3} \times \cancel{a}^1 \times \cancel{b}^1} \\ &= 4a \end{aligned}$$

Explanation

Multiply the coefficients and the pronumerals.
Recall that $x \times x$ is written as x^2 (x squared).

Write numerator and denominator as a product, with $a^2 = a \times a$. Cancel common factor (3) for numerals, then cancel common factors for pronumerals.

Now you try

Simplify the following.

$$\text{a } 7ab \times 6a$$

$$\text{b } \frac{20xy^2}{4xy}$$

3C

5 Simplify the following.

a	$4n \times 6n$	b	$-3q \times q$	c	$5s \times 2s$
d	$7a \times 3ab$	e	$5mn \times (-3n)$	f	$-3gh \times (-6h)$
g	$\frac{24ab^2}{8ab}$	h	$\frac{25x^2y}{5xy}$	i	$\frac{9m^2n}{18mn}$
j	$\frac{2xy}{8xy^2}$	k	$\frac{6a^2b}{10a}$	l	$\frac{45p^2q^2}{15pq}$

Hint: Deal with numerals and pronumerals separately.

$$\frac{24^3}{8^1} \text{ and } \frac{ab^2}{ab} = \frac{a^1 \times b \times b^1}{a^1 \times b^1} = b$$



Problem-solving and reasoning

6(½), 7

6(½), 7–9

6 Simplify the following by first writing in fraction form.

a	$4 \times x \div y$	b	$3 \times m \div 9$	c	$4 \times a \div (2b)$
d	$5x \times 4 \div (2y)$	e	$6 \times 4mn \div (3m)$	f	$8a \times 5b \div (8a)$
g	$10m \times 4n \div (8mn)$	h	$4x \times 3xy \div (2x)$		
i	$3pq \times p \div (6q)$	j	$5ab^2 \times 4 \div (10b)$		

Hint: Apply one operation at a time from left to right in these; e.g. $4 \times x \div y = 4x \div y$

$$= \frac{4x}{y}$$



7 Write a simplified expression for the area of the following shapes.

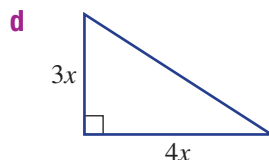
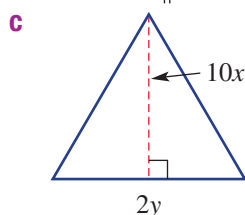
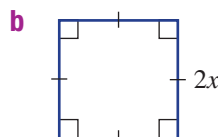
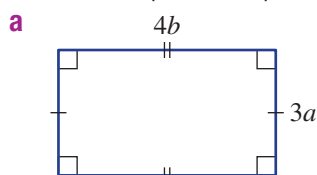

Hint: Area of a triangle = $\frac{1}{2} \times \text{base} \times \text{height}$



8 A bag of lollies contains x jelly beans. Jean buys 6 bags of lollies to share equally among her three grandchildren. Write a simplified expression for how many jelly beans each grandchild receives.

9 Fill in the missing term to make each of the following correct.

a	$3m \times \square = 12mn$	b	$4x \times \square = 28xy$	c	$-2xy \times \square = -18xy^2$
d	$6a \times \square = 30a^2b$	e	$\frac{\square}{7} = 2x$	f	$\frac{15}{\square} = \frac{3}{2y}$
g	$\frac{\square}{18ab} = \frac{2}{3b}$	h	$\frac{\square}{4x} = 2xy$	i	$\frac{\square}{2x} = 5x$



Rectangular paddocks

—

10, 11

10 The length of a rectangular paddock is three times its width. Its width is x metres. It is bordered on one side by a stream.

a Write a simplified expression for the:

- area of the paddock
- length of fencing needed for the three sides of the paddock

b If $x = 50$, use your answers to part a to give the:

- area of the paddock
- length of fencing material required.

11 Another rectangular paddock has its area given by the expression $4ab^2$. Find the width of the paddock if the length is:

a	ab	b	$2b$	c	$4ab$
---	------	---	------	---	-------

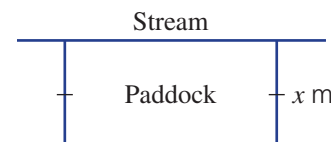

3D Expanding algebraic expressions

Learning intentions

- To know how the distributive law is used to expand and remove brackets
- To be able to apply the distributive law to expand brackets
- To be able to simplify expressions involving brackets and like terms

Key vocabulary: distributive law, expand, like terms

We know from previous sections that, when brackets are used in expressions, we need to do the mathematics inside the brackets first.

For example, the expression $2(x + 3)$ means 'first add three to x , and then double the result'.

If $x = 10$, we get $2 \times (10 + 3) = 2 \times 13 = 26$.

Similarly, if we multiply each term inside the brackets separately by 2, the result is also 26:

$$(2 \times 10) + (2 \times 3) = 20 + 6 = 26.$$

We can apply this to algebraic expressions, so that $2(x + 3)$ can also be written as $2 \times x + 2 \times 3 = 2x + 6$. This uses the distributive law for addition.

Lesson starter: Rectangular distributions

This rectangle has the dimensions as shown. Given that the area of a rectangle is length \times width:

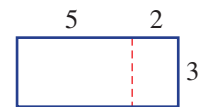

- describe two different ways to find the area of the rectangle
- fill in the boxes below to show the two methods used

$$\square (\square + \square) = \square \times \square + \square \times \square$$

This diagram also shows two joined rectangles with the given dimensions, with one unknown, x .

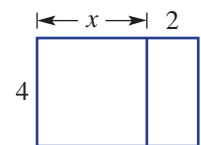

- Use your methods from above to find two different ways to write expressions for the combined area of the two rectangles.
- Complete the following: $4(\underline{\hspace{2cm}}) = \underline{\hspace{2cm}} + \underline{\hspace{2cm}}$

Key ideas

- The **distributive law** is used to **expand** and remove brackets.
 - It states that adding numbers in brackets, *then* multiplying the total, gives the same answer as multiplying each number in the brackets separately first, *then* adding the products.
- To expand brackets:
 - The term on the outside of the brackets is multiplied by each term inside the brackets.

$$a(b + c) = ab + ac \quad \text{or} \quad a(b - c) = ab - ac$$

For example:

$$2(x + 4) = 2 \times x + 2 \times 4 = 2x + 8$$

- If the number in front of the brackets is negative, the sign of each of the terms inside the brackets will change when expanded.

For example: $-2(x - 3) = -2x + 6$ since $-2 \times x = -2x$ and $-2 \times (-3) = 6$

Exercise 3D

Understanding

1-4

4

- 1 This diagram shows two joined rectangles with the given dimensions.
- Write an expression for the area of:
 - the larger rectangle (x by 5)
 - the smaller rectangle (2 by 5)
 - Use your answers from part **a** to find the combined area of both rectangles.
 - Write an expression for the total side length of the side involving x .
 - Use your answer from part **c** to find the combined area of both rectangles. You will need brackets.
 - Complete this statement: $5(x + 2) = \underline{\hspace{2cm}} + \underline{\hspace{2cm}}$

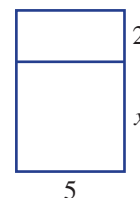

- 2 Complete the following:
To expand brackets the _____ on the outside of the brackets is _____ by each term _____ the brackets.
- 3 Using the distributive law, $x(y - z)$ is equivalent to
- A** $xy - z$ **B** $xy + z$ **C** $xy - xz$ **D** $-xyz$
- 4 Fill in the boxes to complete the following.
- a** $3(x + 5) = \square \times x + \square \times 5$
 $= 3x + \square$
- b** $-4(x + 2) = \square \times x + \square \times 2$
 $= \square - \square$

Fluency

5-7(½)

5-8(½)



Example 11 Expanding simple expressions with brackets

Expand the following.

a $3(x + 4)$

b $5(x - 11)$

Solution

Explanation

a $3(x + 4) = 3x + 12$

The 3 on the outside is multiplied by each term inside the brackets; i.e.

$$\overbrace{3(x + 4)} = 3 \times x + 3 \times 4$$

b $5(x - 11) = 5x - 55$

$$5 \times x = 5x \text{ and } 5 \times (-11) = -55$$

Now you try

Expand the following.

a $4(x + 2)$

b $6(x - 10)$

- 5 Expand the following.

a $2(x + 3)$

b $5(x + 12)$

c $2(x + 7)$

d $7(x + 9)$

e $3(x - 7)$

f $6(x - 11)$

g $5(x - 9)$

h $10(x - 1)$

i $3(2 + x)$

j $7(3 + x)$

k $4(7 - x)$

l $5(8 - x)$

Hint: Remember that the number in front of the brackets is multiplied by each term inside the brackets when expanding:

$$\overbrace{2(x + 3)} = \dots$$



**Example 12 Expanding brackets with a negative number in front**

Expand the following.

a $-2(x + 5)$

b $-3(x - 4)$

Solution**Explanation**

a $-2(x + 5) = -2x - 10$

 -2 is multiplied by each term inside the brackets.

$-2 \times x = -2x$ and $-2 \times 5 = -10$

b $-3(x - 4) = -3x + 12$

Multiplying by a negative changes the sign of each term in the brackets.

$-3 \times x = -3x$ and $-3 \times (-4) = +12$

Now you try

Expand the following.

a $-3(x + 7)$

b $-5(x - 9)$

6 Expand the following.

a $-3(x + 2)$

b $-2(x + 11)$

c $-5(x - 3)$

d $-6(x - 6)$

e $-4(2 - x)$

f $-13(3 + x)$

g $-8(9 + x)$

h $-300(1 - x)$

**Example 13 Expanding brackets and simplifying**

Expand the following.

a $4(x + 3y)$

b $2x(4x - 3)$

Solution**Explanation**

a $4(x + 3y) = 4 \times x + 4 \times 3y$
 $= 4x + 12y$

Multiply each term inside the brackets by 4.
 $4 \times x = 4x$ and $4 \times 3 \times y = 12y$.

b $2x(4x - 3) = 2x \times 4x + 2x \times (-3)$
 $= 8x^2 - 6x$

Each term inside the brackets is multiplied by $2x$.

$2x \times 4x = 2 \times 4 \times x \times x = 8x^2$ and

$2x \times (-3) = 2 \times (-3) \times x = -6x$.

Now you try

Expand the following.

a $5(a + 4b)$

b $3y(5y - 4)$

7 Expand the following.

a $2(a + b)$

b $5(a + 2b)$

c $3(2m + y)$

d $8(2x - 5)$

e $-3(4x + 5)$

f $4x(x - 2y)$

g $t(2t - 3)$

h $a(3a + 4)$

i $d(2d - 5)$

j $2b(3b - 5)$

k $2x(4x + 1)$

l $5y(1 - 3y)$

Hint: $x \times x$ is written as x^2 .

3D

Example 14 Simplifying by removing brackets

Expand the following and collect like terms.

a $4(x+5) - 10$

b $2 - 3(x-4)$

Solution**Explanation**

a $4(x+5) - 10 = 4x + 20 - 10$
 $= 4x + 10$

Expand brackets first: $4(x+5) = 4 \times x + 4 \times 5$.
 Then collect like terms and simplify.

b $2 - 3(x-4) = 2 - (3x - 12)$
 $= 2 - 3x + 12$
 $= 14 - 3x$

Expand brackets.

$3(x-4) = 3x - 12$.
 $-(3x - 12) = -1(3x - 12)$, so multiplying by negative 1 changes the sign of each term inside the brackets;
 i.e. $-1 \times 3x = -3x$ and $-1 \times (-12) = +12$.

Now you try

Expand the following and collect like terms.

a $7(x+3) - 15$

b $8 - 2(y-5)$

8 Expand the following and collect like terms.

a $2(x+4) + 3$

b $6(x+3) + 4$

c $5(x+2) - 4$

d $3(x+4) - 2$

e $3 + 4(x-2)$

f $7 + 2(x-3)$

g $2 - 3(x-2)$

h $1 - 5(x-4)$

i $5 - 2(x+3)$

j $12 - 3(x+4)$

k $7 - (x+4)$

l $4 - (3x-2)$

Hint: Expand the brackets first then collect like terms.



Problem-solving and reasoning

9–11

10–13

9 The diagram shows the route taken by a salesperson who travels from A to D via B and C .

- a** If the salesperson then returns directly to A , write an expression (in simplest form) for the total distance travelled.
- b** If $y = x + 1$, write an expression for the total distance the salesperson travels in terms of x only. Simplify your expression.
- c** When $y = x + 1$, how much would the distance have been reduced by (in terms of x) if the salesperson had travelled directly from A to D and straight back to A ?

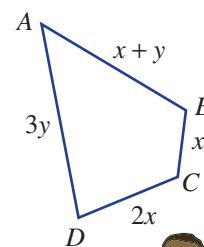

Hint: Subtract the distance from A to D and back again from the total distance.



10 Find the area of these basic shapes in expanded form. All angles are 90° .

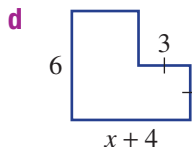
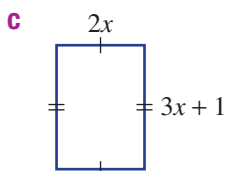
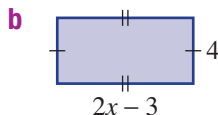
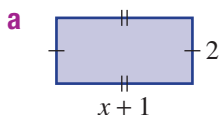

Hint: Remember to include brackets when multiplying length by width.



11 Murray has \$60 in savings. One Saturday, he does some odd jobs for a neighbour and earns \$ x , which he adds to his savings. Murray's parents think he's doing a good job of saving money, so they decide to double his savings. Write an expanded expression for the amount of savings Murray has now.

12 Identify the errors in these expressions then write out the correct expansion.

a $2(x + 6) = 2x + 6$

b $x(x - 4) = 2x - 4x$

c $-3(x + 4) = -3x + 12$

d $-7(x - 7) = -7x - 49$

e $5(x + 2) + 4 = 5x + 6$

f $5 - 2(x - 7) = 5 - 2x - 14$
 $= -9 - 2x$



Hint: Watch out for the negative numbers.



13 Jill pays tax at 20c in the dollar for every dollar earned over \$10 000. Jill earns \$ x and $x > 10\,000$.

a Write an expression for the amount that Jill pays tax on.

b Write an expression for the amount Jill pays in tax. Expand your answer.

Hint: 20c in the dollar is 0.2 of each dollar. In \$10, this is $0.2 \times 10 = \$2$.



Pairs of brackets

—

14, 15

14 Expand each pair of brackets first, then collect like terms.

a $2(x + 3) + 3(x + 2)$

b $2(x + 4) + 2(x - 1)$

c $3(2x + 4) + 5(x - 1)$

d $4(3x + 2) + 5(x - 3)$

e $-2(x + 2) + 3(x - 1)$

f $2(4x - 3) - 2(3x - 1)$

g $x(x + 2) + 2x(x + 4)$

h $3(x - 1) + x(x + 2)$

15 Find the area of these shapes in expanded form. All angles are 90° .

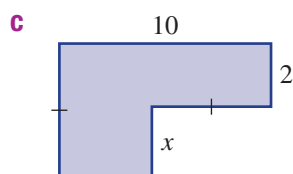
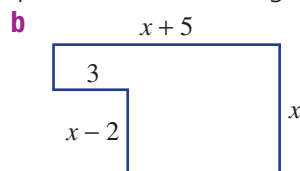
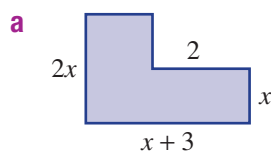

Hint: Split these shapes into rectangles and add or subtract areas.



3E Solving linear equations

CONSOLIDATING

Learning intentions

- To know what represents an equation
- To understand that equivalent equations can be created by applying the same operation to both sides of the equation
- To review the steps for solving simple linear equations involving backtracking
- To be able to solve simple linear equations

Key vocabulary: equation, equivalent equation, solution, substitution, solve

A mathematical statement containing an equals sign, a left-hand side and a right-hand side is called an equation.

$5 = 10 \div 2$, $3x = 9$, $x^2 + 1 = 10$ and $\frac{1}{x} = 4$ are examples of equations. Linear equations can be written in the form $ax + b = c$, where the power of x is 1.

$4x - 1 = 6$, $3 = 2(x + 1)$ and $5x = 2x + 1$ are all linear equations.

Equations are solved by finding the value of the pronumeral that makes the equation true. This can be done by inspection for very simple linear equations (for example, if $3x = 15$ then $x = 5$, since $3 \times 5 = 15$). More complex linear equations can be solved through a series of steps where each step produces an equivalent equation.

→ Lesson starter: Is $x = 4$ a solution?

State which of the following equations has the solution $x = 4$.

$$\begin{array}{lll} 5x = 20 & 2x - 1 = 5 & 10 - x = 14 \\ x + 9 = 13 & 3x + 2 = 14 & -4x = 16 \end{array}$$

- How did you find the equations for which $x = 4$ is a solution?
- The equations you have listed should be equivalent equations to $x = 4$. Starting from $x = 4$, describe what you would do to produce each equivalent equation; for example, 'add 1 to both sides'.

Key ideas

- An **equation** is a mathematical statement containing an equals sign.
For example: $3x + 1 = 7$.
- The **solution** of an equation is the value of the pronumeral that makes the equation true.
- **Equivalent equations** are created by:
 - adding the same number to or subtracting the same number from both sides of the equation
 - multiplying or dividing both sides of the equation by the same number (not including 0).
- Linear equations can be **solved** by creating equivalent equations and using opposite operations (backtracking).
- The solution to an equation can be checked by substituting the solution into the original equation and checking that both sides are equal.

Exercise 3E

Understanding

1–4

3, 4

- 1 Use substitution to state which of these equations has a solution of $x = 3$.

a $x + 5 = 9$

b $1 - x = -4$

c $3x - 2 = 7$

d $4 - 3x = -5$

Hint: If $x = 3$ is a solution, the left hand side must equal the value that is on the right hand side of the $=$ sign.



2 State the value of x that makes these equations true.

a $x + 4 = 10$

b $x - 3 = 5$

c $5x = 20$

Hint: What value plus 4 equals 10?



3 Obtain an equivalent equation by completing the step given in brackets.

a $2x + 5 = 11$ (subtract 5 from both sides)

b $3x - 4 = 17$ (add 4 to both sides)

c $4x = 36$ (divide both sides by 4)

Hint: $2x + 5 = 11$
 -5 $2x = \dots$ -5



4 State the single operation that has been performed to obtain these pairs of equivalent equations; for example, 'add 3 to both sides'.

a $x + 9 = 11$

$x = 2$

b $2x - 1 = 5$

$2x = 6$

c $3x = 27$

$x = 9$

Fluency

5(½), 6

5-7(½)



Example 15 Solving simple linear equations

Solve each of the following equations.

a $2x + 5 = 9$

b $3x - 7 = 11$

Solution

Explanation

a $2x + 5 = 9$

$2x = 4$

$x = 2$

Check:

LHS = $2x + 5$ RHS = 9

= $2 \times (2) + 5$

= $4 + 5$

= 9

Subtract 5 from both sides to undo the +5.

Divide both sides by 2, since $2x = 2 \times x$ and

$$\frac{2^1 \times x}{2^1} = x.$$

Check the answer by substituting $x = 2$ into the original equation to check that the LHS = RHS.

b $3x - 7 = 11$

$3x = 18$

$x = 6$

Check:

LHS = $3x - 7$ RHS = 11

= $3 \times (6) - 7$

= $18 - 7$

= 11

Add 7 to both sides to undo the -7, since $-7 + 7 = 0$.

$3x = 3 \times x$, so divide both sides by 3.

Check your solution by substituting $x = 6$.

Now you try

Solve each of the following equations.

a $3x + 8 = 23$

b $4x - 2 = 10$

3E

- 5 Solve each of the following equations. Check your answers using substitution.

a $2x + 7 = 15$

b $5a + 6 = 11$

c $3m + 4 = 16$

d $2x + 4 = 12$

e $2n + 13 = 17$

f $3x + 5 = -7$

g $5b - 3 = 12$

h $3y - 2 = 19$

i $7a - 8 = 20$

j $4b - 7 = 25$

k $2x - 4 = -6$

l $10y - 35 = -15$

Hint: Think carefully about each step to make sure you do produce an equivalent equation.



Example 16 Solving equations with negative coefficients

Solve the following equations.

a $9 - 2x = 15$

b $7 - 4x = 10$

Solution

Explanation

a $9 - 2x = 15$

$-2x = 6$

$x = -3$

Check:

LHS = $9 - 2x$ RHS = 15

$= 9 - 2 \times (-3)$

$= 9 - (-6)$

$= 15$

b $7 - 4x = 10$

$-4x = 3$

$x = -\frac{3}{4}$

Check:

LHS = $7 - 4x$ RHS = 10

$= 7 - 4 \times \left(-\frac{3}{4}\right)$

$= 7 - (-3)$

$= 10$

Subtract 9 from both sides, leaving $-2x$ on the LHS.

Divide both sides by -2 ; recall that a positive number divided by a negative number is negative.

Check your answer.

Subtract 7 from both sides.

Divide both sides by -4 . Leave your answer in fraction form; i.e. $3 \div (-4) = -\frac{3}{4}$.

Now you try

Solve the following equations.

a $10 - 3x = 16$

b $11 - 5x = 15$

- 6 Solve each of the following equations.

a $12 - 2x = 18$

b $2 - 7x = 9$

c $15 - 5x = 25$

d $3 - 2x = 19$

e $2 - 5x = -8$

f $24 - 7x = 10$

g $14 - 8x = -2$

h $3 - 4x = -21$

- 7 Solve these equations. Leave your answer in fraction form.

a $2x + 5 = 8$

b $5x - 1 = 2$

c $11x - 3 = 7$

d $6 - 2x = 5$

e $4 - 3x = 5$

f $8 - 5x = 4$

Hint: If $5x = 3$, $x = \frac{3}{5}$
(divide both sides by 5).
The answer can be left as a fraction.



Problem-solving and reasoning

8, 9

8(½), 9, 10



Hint: Form the algebraic expression (e.g. $x + 8$) and set it equal to the result to make the equation.

- 8** For each of the following, write an equation and solve it to find the unknown value. Use x as the unknown value.
- If 8 is added to a certain number, the result is 34.
 - Seven less than a certain number is 21.
 - I think of a number, double it and add 4. The result is 10.
 - I think of a number, triple it and subtract 4. The result is 11.
 - Four less than three times a number is 20.
 - I start with the number 25 and subtract twice a certain number. The result is 7.
- 9** Describe the error made in each of these incorrect solutions.
- | | |
|--|---|
| <p>a $3x + 2 = 8$
$3x = 10$
$x = \frac{10}{3}$</p> | <p>b $2x - 1 = 5$
$2x = 6$
$x = 12$</p> |
| <p>c $5 - x = 12$
$x = 7$</p> | <p>d $2x + 3 = 8$
$x + 3 = 4$
$x = 1$</p> |
- 10** Solve these equations.
- $-3 + 4x = 17$
 - $-5 - 2x = 13$
 - $-10 - 3x = -4$



Is the car speeding?

—

11

- 11** A car is travelling in zones where speed signs are in metres per second (m/s).
- When it first sets out, its speed (s m/s) is given by $s = 2t$, where t is time in seconds. How long does it take for the car to reach a speed of 20 m/s (this is 72 km/h)?
 - The car starts to accelerate again, and its speed is now given by $s = 16 + 1.5t$. For how many seconds can it continue this acceleration before it reaches 28 m/s (about 100 km/h)?



3F Solving linear equations involving fractions

Learning intentions

- To know how to write pronumerals with fractional coefficients in fraction form
- To know that multiplication and division are inverse operations
- To understand the order in which steps need to be applied to solve equations involving fractions
- To be able to solve linear equations involving fractions

Key vocabulary: coefficient, equation, equivalent equation, inverse

We saw in the previous section that to solve an equation such as $2x = 8$, we divide each side of the equation by 2.

What happens if the equation involves a fraction? For the equation $\frac{1}{2}x = 2$, we could similarly divide both sides by $\frac{1}{2}$ to solve it. But we can also write the equation in a different way, to make it easier to solve.

A half of x is equivalent to dividing x by 2, so $\frac{1}{2}x = 5$ can be written as $\frac{x}{2} = 5$.

To solve this new equation, we can multiply both sides by 2, since $2 \times \frac{x}{2} = x$. This gives us $x = 10$.

From this process, we can see that we could solve this equation by either dividing both sides by $\frac{1}{2}$ or multiplying both sides by 2.

For more complex equations we'll also need to consider the order of operations.

→ Lesson starter: Fractions of x

Consider these problems involving fractions.

- 1 If half of x is 8, what is x ?
- 2 If a third of x is 5, what is x ?
- 3 If three-quarters of x is 30, what is x ?
 - Discuss the methods you used to find the value of x .
 - Write an equation to represent each case.
 - Discuss how your method for finding the answer relates to the fraction in the equation.

Key ideas

- Pronumerals with a fraction coefficient can be expressed in fraction form; i.e. $\frac{1}{3}x = \frac{x}{3}$ and $\frac{3}{5}x = \frac{3x}{5}$.
- Multiplication and division are **inverse** operations; i.e. $2 \times 3 = 6$ and $\frac{6}{2} = 3$.
- Equations involving fractions are also solved by creating a series of simpler equivalent equations.

For example: $\frac{2x}{3} = 8$

$$2x = 24$$

$$x = 12$$

- At some stage both sides of the equation can be multiplied by the number in the denominator of the fraction. The order of when this happens is important.

For example: $\frac{x-1}{2} = 4$ is different from $\frac{x}{2} - 1 = 4$

$$\begin{array}{l} x - 1 = 8 \\ x = 9 \end{array} \qquad \begin{array}{l} \frac{x}{2} = 5 \\ x = 10 \end{array}$$

Exercise 3F

Understanding

1-4

4

- Fill in the boxes to produce an equivalent expression.
 - $\frac{1}{5}x = \frac{x}{\square}$
 - $\frac{3x}{4} = \square x$
 - $-\frac{2}{3}x = -\frac{\square}{3}$
- Write down the value of x that is the solution to these equations. No written working is required.
 - $\frac{x}{2} = 10$
 - $\frac{x}{4} = 6$
 - $\frac{x+1}{3} = 4$
 - $\frac{x}{5} - 2 = 1$
- Which one of the following is an equivalent equation to $\frac{x}{4} + 1 = 8$?
 - $x + 1 = 32$
 - $x = 36$
 - $\frac{x}{4} = 7$
 - $\frac{x+1}{4} = 2$
- Match each equation in the first column with its equivalent equation in the second column and state the single operation that generates the equivalent equation (for example, multiply both sides by 5).

<ol style="list-style-type: none"> $\frac{x}{3} - 1 = 2$ $\frac{x}{4} = 2$ $\frac{x+2}{3} = 1$ $\frac{x-1}{2} = 3$ 	<ol style="list-style-type: none"> $x + 2 = 3$ $x - 1 = 6$ $x = 8$ $\frac{x}{3} = 3$
--	--

Hint: Think about what step you would apply first to produce a simple equivalent equation.





Example 17 Solving linear equations with fractional coefficients

Solve each of the following equations.

a $\frac{2x}{3} = 8$

b $\frac{x}{4} - 3 = 7$

Solution

Explanation

a $\frac{2x}{3} = 8$

$$2x = 24$$

$$x = 12$$

Check:

$$\text{LHS} = \frac{2x}{3} \quad \text{RHS} = 8$$

$$= \frac{2 \times (12)}{3}$$

$$= \frac{24}{3}$$

$$= 8$$

Multiply both sides by 3 to remove the fraction on the left-hand side. Then divide both sides by 2.

Check that $x = 12$ makes LHS = RHS.

b $\frac{x}{4} - 3 = 7$

$$\frac{x}{4} = 10$$

$$x = 40$$

Check:

$$\text{LHS} = \frac{x}{4} - 3 \quad \text{RHS} = 7$$

$$= \frac{40}{4} - 3$$

$$= 10 - 3$$

$$= 7$$

Add 3 to both sides first to undo the -3 .

Multiply both sides by 4.

Check the answer by substituting $x = 40$ into $\frac{x}{4} - 3$.

Since this equals 7, $x = 40$ is the solution.

Now you try

Solve each of the following equations.

a $\frac{3x}{4} = 6$

b $\frac{x}{2} - 5 = 10$

5 Solve each of the following equations.

a $\frac{x}{5} = 3$

b $\frac{y}{2} = 7$

c $\frac{2y}{5} = 4$

d $\frac{3x}{2} = 6$

e $\frac{x}{4} + 3 = 5$

f $\frac{x}{2} + 4 = 5$

g $\frac{b}{3} + 5 = 9$

h $\frac{t}{2} + 5 = 2$

i $\frac{a}{3} + 4 = 2$

j $\frac{y}{5} - 4 = 2$

k $\frac{x}{3} - 7 = -2$

l $\frac{s}{2} - 3 = -1$

m $\frac{x}{4} - 5 = -2$

n $\frac{m}{4} - 2 = -3$

o $\frac{y}{5} + 4 = -3$

Hint: In part e, the first step is to subtract 3 from both sides.



Example 18 Solving simple fractional equations

Solve the equation $\frac{x+4}{6} = 2$.

Solution

$$\frac{x+4}{6} = 2$$

$$x+4 = 12$$

$$x = 8$$

Check:

$$\text{LHS} = \frac{x+4}{6}$$

$$\text{RHS} = 2$$

$$= \frac{(8)+4}{6}$$

$$= \frac{12}{6}$$

$$= 2$$

Explanation

Multiply both sides by 6 first, since all of $(x+4)$ is divided by 6.

Subtract 4 from both sides and check the answer.

Now you try

Solve the equation $\frac{x-5}{3} = 4$.

6 Solve each of the following equations. Check your answers.

a $\frac{x+1}{3} = 4$

b $\frac{x+4}{2} = 5$

c $\frac{y+4}{3} = 2$

d $\frac{b+6}{2} = 3$

e $\frac{y-2}{3} = 6$

f $\frac{t-4}{5} = 7$

g $\frac{k-1}{7} = 8$

h $\frac{x-7}{9} = 7$

i $\frac{x+2}{4} = -2$

j $\frac{b+3}{7} = -3$

k $\frac{y-3}{5} = -5$

Hint: Think carefully about the order of the steps here.



7 Solve this mixed selection of equations.

a $2t+1 = 7$

b $\frac{m}{4} - 2 = 8$

c $5 - 2y = 9$

d $\frac{x-4}{5} = 3$

e $3 + \frac{y}{6} = 2$

f $4t - 5 = -8$

3F

Problem-solving and reasoning

8, 9

8(½), 9, 10, 11(½)

- 8 For each of the following, write an equation and solve it to find the unknown value. Use x as the unknown value.

- a If a certain number is divided by 3, the result is 12.
 b A certain number is doubled, then divided by 5. The result is 4.
 c I think of a number, halve it and subtract 4. The result is 10.
 d I think of a number, add 3 and divide this by 4. The result is 6.
 e A number is multiplied by 7 and the product is divided by 3. The final result is 8.
 f 5 is added to a third of a certain number. The result is 16.

Hint: x halved is $\frac{x}{2}$.A third of x is $\frac{x}{3}$.

- 9 A bag of chocolate eggs containing x eggs is shared equally between India and her two brothers. After India eats 2, she has 5 left. How many eggs were in the bag?



Hint: Start with an expression for the number of eggs India first receives.



- 10 Describe the error made in each of these incorrect solutions. Then write out the correct solution.

a $\frac{x+2}{3} = 7$

$\frac{x}{3} = 5$

$x = 15$

b $\frac{x}{3} - 4 = 2$

$x - 4 = 6$

$x = 10$

- 11 Solve these equations involving more than two steps.

a $\frac{2x}{3} - 1 = 7$

b $\frac{3x}{4} - 2 = 7$

c $\frac{x}{2} + 3 = 1$

d $\frac{3b-8}{2} = 5$

e $\frac{2x+2}{3} = 4$

f $\frac{7m-8}{3} = 9$

g $\frac{5-y}{3} = 2$

h $\frac{4-2t}{6} = 3$

i $1 - \frac{4x}{3} = 5$

Hint: Keep operating on both sides of the equation until you find the solution.



Fractional coefficients

—

12, 13

- 12 Solve these equations involving fractional coefficients.

a $\frac{2}{3}x = 6$

b $\frac{5}{6}x = 30$

c $-\frac{2}{7}x = 2$

d $\frac{3}{4}x - 1 = 5$

e $\frac{7}{5}x - 3 = 4$

f $1 - \frac{3}{5}x = 7$

- 13 If $\frac{7}{5}x = 14$, does it matter whether you multiply by 5 first or divide by 7 first? Which method would be best here?

- 3A** 1 Consider the expression $4x - 5xy - 3y + 8$.
- How many terms are in the expression?
 - What is the coefficient of y ?
 - What is the constant term?
- 3A** 2 Write algebraic expressions for the following.
- The cost of 3 drinks at $\$d$ each
 - $\$500$ winnings shared equally between x people
 - Four less than three lots of y
 - The sum of m and n doubled
- 3A** 3 Evaluate these expressions if $x = 3$, $y = -4$ and $z = 7$.
- $2y + z$
 - $xy - y$
 - $y^2 + x - z$
- 3B** 4 Simplify the following by collecting like terms.
- $5x + 7x$
 - $8b - b$
 - $12a + 5 - 3a$
 - $6xy - 4x + 2xy$
 - $4a + 7b - a + 3b$
 - $5mn + 2n + mn - 5n$
 - $4xy^2 - 5xy - 2xy^2 + 3yx$
 - $3a^2b + 2ab^2 - a^2b + 5ab^2$
- 3C** 5 Simplify the following.
- $6 \times 4b$
 - $3a \times 8c$
 - $-5x \times 4y$
 - $7ab \times 4b$
 - $\frac{3x}{12}$
 - $\frac{6xy}{8x}$
 - $\frac{9x^2y}{6x}$
 - $6x \times 4y \div (3y)$
- 3D** 6 Expand the following.
- $3(x + 5)$
 - $4(y - 1)$
 - $-2(x + 5)$
 - $-5(a - 2)$
 - $6(2x - 5y)$
 - $3m(4m + n)$
- 3D** 7 Expand the following and collect like terms.
- $3(2x - 5) + 7$
 - $8 - 4(x + 3)$
 - $1 - (2x - 1)$
- 3E** 8 Solve the following equations.
- $3x + 2 = 11$
 - $5x - 3 = 17$
 - $8 - 2x = 26$
 - $12 - 5x = 15$
- 3F** 9 Solve the following equations involving fractions.
- $\frac{x}{7} = 4$
 - $\frac{x}{3} + 6 = 22$
 - $\frac{x - 7}{2} = 10$
 - $\frac{x + 1}{3} = -7$
- 3E/3F** 10 Write an equation to find the unknown number x in the following and solve it.
- Five more than three times the number is 32.
 - Three less than the number is divided by 4 to give 5.

3G Solving equations with brackets

Learning intentions

- To know that equations involving brackets can be solved by first expanding the brackets
- To understand that equations with a common factor can be simplified by first dividing both sides by the factor
- To be able to solve equations involving brackets

Key vocabulary: expand, equation

Just as we have seen expressions involving brackets, linear equations may also involve brackets. Brackets can be removed by expanding and then the remaining equation can be solved. Collection of like terms may also be required.

→ Lesson starter: To expand or not to expand?

The steps to solve two problems involving brackets are listed here in the incorrect order.

1 $3(x + 4) = 14$

$$x = \frac{2}{3}$$

$$3x + 12 = 14$$

$$3x = 2$$

2 $3(x + 2) = 12$

$$x = 2$$

$$x + 2 = 4$$

- Arrange the steps in the correct order, working from top to bottom.
- By considering all the steps in the correct order, explain what has happened in each step.
- Describe the two different approaches to solving the problems.
- Can you see why these methods have been used in each case?
- Apply method 1 to the second equation.

Key ideas

- Equations with brackets can be solved by first expanding the brackets and then solving the remaining equation.
For example: $3(x + 1) = 2$ becomes $3x + 3 = 2$.
- An alternate method is to deal with the common factor first.
For example: $5(x - 1) = 15$ becomes $x - 1 = 3$ by first dividing both sides by 5.
- For equations like $2(x + 4) + 3x = 28$ the brackets are always expanded first, then collect any like terms on the LHS and continue to solve as usual.

Exercise 3G

Understanding

1-3

3

- 1 Complete the missing parts to produce an equation without brackets.

a

$$\begin{aligned} 3(x + 7) &= 25 \\ 3 \times \square + \square \times 7 &= 25 \\ 3x + \square &= 25 \end{aligned}$$

b

$$\begin{aligned} 4(2x - 1) &= 15 \\ \square \times 2x + 4 \times \square &= 15 \\ \square - 4 &= 15 \end{aligned}$$

2 Give the equivalent equation that results from dividing both sides of the equation by the number in front of the brackets.

a $3(x+2) = 9$

b $4(x-3) = 20$

c $-2(x+6) = 8$

3 Expand these expressions and simplify.

a $3(x-4) + x$

b $5(x-3) - 3x$

c $4(x+2) - 6x$

Fluency

4-5(½)

4-6(½)



Example 19 Solving equations with brackets

Solve $2(3x - 4) = 11$.

Solution

$$2(3x - 4) = 11$$

$$6x - 8 = 11$$

$$6x = 19$$

$$x = \frac{19}{6} \text{ or } 3\frac{1}{6}$$

Explanation

Expand the brackets:

$$2(3x - 4) = 2 \times 3x + 2 \times (-4)$$

Solve the remaining equation by adding 8 to both sides, then dividing both sides by 6.

Leave your answer in fraction form.

Now you try

Solve $3(2x - 5) = 7$.

4 Solve each of the following equations by first expanding the brackets.

a $2(x+3) = 11$

b $5(a+3) = 18$

c $3(m+4) = 31$

d $5(y-7) = 12$

e $4(p-5) = 15$

f $2(k-5) = 9$

g $4(5-b) = 21$

h $2(1-m) = 13$

i $5(3-x) = 19$

j $7(2a+1) = 8$

k $4(3x-2) = 30$

l $3(3n-2) = 0$

m $5(3-2x) = 16$

n $6(1-2y) = 8$

Hint: Once you have expanded the brackets, the equation can be solved in the usual way.



Example 20 Solving equations with brackets and collecting like terms

Solve $6(x+3) - 4x = 32$.

Solution

$$6(x+3) - 4x = 32$$

$$6x + 18 - 4x = 32$$

$$2x + 18 = 32$$

$$2x = 14$$

$$x = 7$$

Explanation

Expand the brackets first, then collect any like terms:

$6x - 4x = 2x$. Solve the remaining equation by subtracting 18 from both sides, and then divide both sides by 2.

Now you try

Solve $5(x+4) - 2x = 35$.

3G

5 Expand and simplify, then solve each of the following equations.

a $2(x + 4) + 2x = 12$

b $2(x - 3) + 3x = 4$

c $6(x + 3) - 2x = 26$

d $5(x + 2) - 2x = 46$

e $3(2x - 3) + x = 12$

f $4(3x + 1) - 3x = 19$

g $2(3x + 5) - 8x = 20$

h $4(1 - x) - x = 9$

6 Solve these equations.

a $4(x - 1) + x - 1 = 0$

b $3(x + 2) - 2 + 4x = 18$

c $3(2x + 3) - 1 - 4x = 10$

d $2(4x - 1) - 5x + 6 = 31$

e $2(4x + 2) - 10x - 6 = 6$

f $5(2x + 3) - 15x - 7 = 3$

Hint: Expand the brackets and then combine like terms before solving.



Problem-solving and reasoning

7, 8

7(½), 9, 10

7 Using x for the unknown number, write down an equation then solve it to find the number. The first one is done for you.

a Three times 1 more than a number is 4. ($3(x + 1) = 4$; $x = \frac{1}{3}$)

b Twice 2 less than a number is 19.

c The product of 2 and 3 more than a number is 7.

d The product of 3 and 4 less than a number is 8.

e When 2 less than 3 lots of a number is doubled, the result is 5.

f When 5 more than 2 lots of a number is tripled, the result is 10.

Hint: You will need to use brackets when setting up the expressions in these equations.



8 Since Tara started her job, her original hourly wage ($\$x$) has been tripled, then decreased by $\$6$. Her pay is now to be doubled so that she earns $\$18$ an hour. What was her original hourly wage?



Hint: Tripling Tara's pay of $\$x$ is $3 \times x = 3x$.



9 Consider the equation $3(x - 2) = 9$.

a Solve the equation by first dividing both sides by 3.

b Solve the equation by first expanding the brackets.

c Which of the above two methods is preferable and why?

Hint: You may recall this idea from the 'Lesson starter' activity at the beginning of the section.



10 Consider the equation $3(x - 2) = 7$.

a Solve the equation by first dividing both sides by 3.

b Solve the equation by first expanding the brackets.

c Which of the above two methods is preferable and why?



Brackets or no brackets?

—

11

11 Decide if brackets need to be inserted into the following equations to make $x = 4$ the solution. If so, insert the brackets where required.

a $3x - 2 = 10$

b $6x - 12 = 12$

c $4x + 1 = 20$

d $2x - 4 + 3x + 1 = 13$

e $3x + 2 + 2x - 5 = 12$

f $2x - 3 - 3x - 1 = -4$



Using a calculator 3G: Solving equations

This activity can be found in the More Resources section of the Interactive Textbook in the form of a printable PDF.

3H Solving equations with pronumerals on both sides

Learning intentions

- To be able to collect pronumerals on one side of the equation using addition or subtraction
- To be able to solve equations with pronumerals on both sides of the equation

Key vocabulary: pronumeral, expand, equation, coefficient

More complex linear equations may have pronumerals on both sides of the equation and/or brackets. Examples are $3x = 5x - 1$ or $4(x + 2) = 5x$.

We've seen that brackets can be removed by expanding. Equations with pronumerals on both sides can be solved by collecting like terms using addition and subtraction.



Lesson starter: What is it worth?

Consider these two cases, where red buttons and blue buttons are shown on either side of a dividing line. In each case, the buttons on either side of the line have an equivalent value.

1

•••		•••••
••		•

2

••••		•••
••		•••

- In each case, find how many red buttons one blue button is worth.
- Describe the steps that helped you arrive at your answer.
- Carry out similar steps in the following cases to find what x is worth if each side of the dividing line is equivalent.

1

$4x$		$2x$
		$+10$

2

$5x$		x
		$+4$
		$+12$

- Use the same thought processes to write out the steps for solving:
 $4x = 2x + 10$
 $5x + 4 = x + 12$

Key ideas

- If an equation has pronumerals on both sides, collect them on one side by adding or subtracting one of the terms.
For example: $3x + 4 = 2x - 3$ becomes $x + 4 = -3$ by subtracting $2x$ from both sides.
- The resulting equation will be simplest if the pronumeral is collected on the side with the higher coefficient. For example, in $5x + 2 = 4x + 7$, collect the pronumeral on the left hand side, since 5 is greater than 4.

Exercise 3H

Understanding

1–3

3

- 1 State which side (left or right) you would collect the x terms on to keep the x coefficient positive.

a $5x = 2x + 3$ **b** $6x + 1 = 2x + 5$
c $3x - 5 = 7x + 3$ **d** $1 - 2x = 3x - 9$

Hint: The x coefficient is the numeral multiplied by the x .



- 2 State the step you would carry out to collect the x terms on the left hand side; e.g. 'subtract $2x$ from both sides'.

a $7x = 3x + 4$ **b** $9x + 2 = 5x + 10$
c $3x - 1 = 3 - x$ **d** $4x + 2 = 8 - 2x$

Hint: For $3 - x$, adding x makes 3.



- 3 Show the next step only for the given equations and instructions.

a $3x = x + 6$ (subtract x from both sides)
b $4x - 3 = 2x + 1$ (subtract $2x$ from both sides)
c $2x = 1 - 3x$ (add $3x$ to both sides)
d $4 - x = 8 + 5x$ (add x to both sides)

Fluency

4–6(½)

4–6(½)



Example 21 Solving equations with pronumerals on both sides

Solve these equations with pronumerals on each side.

a $4x = 2x + 10$

b $3x = 16 - 5x$

Solution

Explanation

a $4x = 2x + 10$

$2x = 10$

$x = 5$

Check:

$$\begin{array}{ll} \text{LHS} = 4x & \text{RHS} = 2x + 10 \\ = 4 \times (5) & = 2 \times (5) + 10 \\ = 20 & = 20 \end{array}$$

Collect x terms on LHS (since the x coefficient is larger on that side) by subtracting $2x$ from both sides: $4x - 2x = 2x$.

Solve by dividing both sides by 2 and check that $x = 5$ gives the same value for $4x$ and $2x + 10$.

b $3x = 16 - 5x$

$8x = 16$

$x = 2$

Check:

$$\begin{array}{ll} \text{LHS} = 3x & \text{RHS} = 16 - 5x \\ = 3 \times (2) & = 16 - 5 \times (2) \\ = 6 & = 16 - 10 \\ & = 6 \end{array}$$

Collect x terms by adding $5x$ to both sides (collect on LHS since $3x$ coefficient is positive). Divide both sides by 8 and check the solution.

Now you try

Solve these equations with pronumerals on each side.

a $8x = 5x + 12$

b $2x = 18 - 4x$

4 Solve these equations by first collecting the pronumeral on one side.

a $7x = 5x + 8$

b $8x = 3x + 15$

c $9x = 5x + 12$

d $10x = 9x + 7$

e $4x = x - 9$

f $6x = 2x - 8$

g $3x = 10 - 2x$

h $x = 12 - 2x$

i $x = 12 - x$

j $4x = 14 - 3x$

Hint: Remember: It is easier to collect on the side that will keep the x coefficient positive.



Example 22 Solving equations with pronumerals and numerals on both sides

Solve each of the following equations.

a $5x + 2 = 3x + 6$

b $3 - 2x = 5x - 4$

Solution

Explanation

a $5x + 2 = 3x + 6$

$$2x + 2 = 6$$

$$2x = 4$$

$$x = 2$$

Check:

$$\begin{array}{l} \text{LHS} = 5 \times (2) + 2 \\ = 12 \end{array} \quad \begin{array}{l} \text{RHS} = 3 \times (2) + 6 \\ = 12 \end{array}$$

b $3 - 2x = 5x - 4$

$$3 = 7x - 4$$

$$7 = 7x$$

$$1 = x$$

$$\therefore x = 1$$

Check:

$$\begin{array}{l} \text{LHS} = 3 - 2 \times (1) \\ = 1 \end{array} \quad \begin{array}{l} \text{RHS} = 5 \times (1) - 4 \\ = 1 \end{array}$$

Collect x terms on one side by subtracting $3x$ from both sides: $5x - 3x = 2x$. Collect on the side with the larger x term to keep it positive. Solve the remaining equation.

Check by substituting $x = 2$ into $5x + 2$ and $3x + 6$ to see that it gives the same result for both.

Add $2x$ to both sides to collect x terms on the side with the positive x coefficient. Solve the remaining equation by adding 4 to both sides and dividing both sides by 7. Rewrite with x on the left.

Now you try

Solve each of the following equations.

a $7x + 3 = 4x + 15$

b $8 - x = 4x - 2$

5 Solve each of the following equations.

a $5x - 3 = 4x + 5$

b $9a + 3 = 8a + 6$

c $3m - 8 = 2m$

d $12x - 3 = 10x + 5$

e $8x + 4 = 12x - 16$

f $3x + 7 = 8x - 8$

g $2x + 6 = 9 - x$

h $3y + 6 = 14 - y$

i $5m - 18 = 15 - 6m$

j $4 - 7x = 2x - 23$

k $8 - 2b = 4b + 14$

l $3 - 4m = 3m + 24$

Hint: Collect the pronumerals on one side first.



3H



Example 23 Solving equations with brackets and pronumerals on both sides

Solve these equations involving brackets.

a $7(x + 2) = 3x + 2$

b $3(2x + 4) = 8(x + 1)$

Solution

a $7(x + 2) = 3x + 2$

$$7x + 14 = 3x + 2$$

$$4x + 14 = 2$$

$$4x = -12$$

$$x = -3$$

b $3(2x + 4) = 8(x + 1)$

$$6x + 12 = 8x + 8$$

$$12 = 2x + 8$$

$$4 = 2x$$

$$2 = x$$

$$\therefore x = 2$$

Explanation

Expand the brackets first, then subtract $3x$ from both sides to collect x terms.

Subtract 14 from both sides ($2 - 14 = -12$) and divide by 4. Recall that a negative number divided by a positive number is negative ($-12 \div 4 = -3$).

Expand the brackets on each side.

Subtract $6x$ from both sides. (Subtracting $6x$ keeps the x -coefficient positive, as alternatively subtracting $8x$ would end up with $-2x + 12 = 8$.) Solve the equation and make x the subject.

Now you try

Solve these equations involving brackets.

a $5(x + 3) = 3x + 7$

b $4(2x - 1) = 6(x + 2)$

6 Solve each of the following equations.

a $5(x - 2) = 2x + 11$

b $3(a + 1) = a + 13$

c $3(y + 4) = y + 16$

d $2(x + 5) = x - 4$

e $5b - 4 = 6(b + 2)$

f $2(4m - 5) = 4m + 2$

g $3(2a - 3) = 5(a + 2)$

h $4(x - 3) = 3(3x + 1)$

i $3(x - 2) = 5(x + 4)$

j $3(n - 2) = 4(n - 5)$

k $2(a + 5) = 2(2a + 3)$

l $4(x + 2) = 3(2x + 1)$

Hint: Expand the brackets before collecting the pronumerals on one side.



Problem-solving and reasoning

7, 8

7(1/2), 8, 9

7 Using x for the unknown number, write down an equation then solve it to find the number. The first one has been done for you as an example.

a Twice a number is equal to 4 less than 3 times a number. ($2x = 3x - 4$; $x = 4$)

b 4 more than 2 lots of a number is equal to 5 times the number.

c 10 more than 3 lots of a number is equivalent to 5 lots of the number.

d 2 more than 3 times the number is equivalent to 6 less than 5 times the number.

e 1 less than a doubled number is equivalent to 5 more than 3 lots of the number.

f 4 more than 2 lots of a number is equivalent to the number subtracted from 13.

- 8 Mardy is x years old. He correctly tells his mother that she is 6 years older than 3 times his age. His mother replies that she is also 10 years younger than 5 times his age. How old is Mardy?

Hint: Build the equation step by step. You should get two expressions for Mardy's mother's age.



- 9 Consider the equation $3x + 1 = 5x - 7$.
- Solve the equation by first subtracting $3x$ from both sides.
 - Solve the equation by first subtracting $5x$ from both sides.
 - Which method above do you prefer and why? Describe the differences.



Matching sides

—

10

- 10 Use the properties of these basic shapes to find their perimeters.

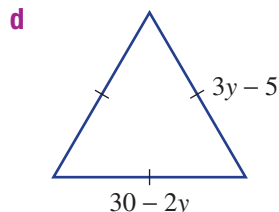
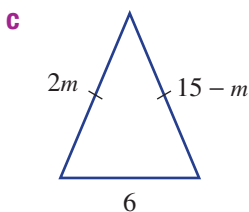
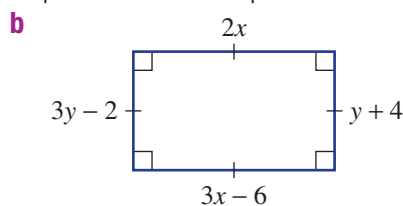
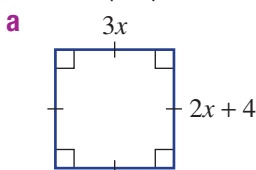

Hint: Find the value of each pronumeral first by setting up and solving an equation.



31 Solving word problems

Learning intentions

- To be able to define a variable to represent the unknown in a problem
- To be able to write an equation to represent a word problem
- To be able to use algebra to solve a word problem

Key vocabulary: pronumeral, variable, equation

Many types of problems can be solved by writing and solving linear equations. Often problems are expressed only in words. Reading and understanding the problem, defining a pronumeral and writing an equation become important steps in solving the problem.

Lesson starter: Too much television?

Three friends, Rick, Kate and Sue, compare how much television they watch in a week at home. Kate watches 3 times the amount of television that Rick watches. Sue watches 4 hours less television than Kate. In total they watch 45 hours of television. How many hours of television did Rick watch?



- Underline each piece of important information in the question.
- Circle the item in the question that you are being asked to find.

Let x hours be the number of hours of television watched by Rick.

- Write expressions for the number of hours of television watched by:
 - a** Kate
 - b** Sue
- Add up the number of hours watched by Rick, Kate and Sue using your expressions.
- Write an equation using all the information in the question.
- Solve the equation.
- Answer the question in the original problem.

Key ideas

- To solve a word problem using algebra:
 - Read the problem and find out what the question is asking for.
 - Define a pronumeral and write a statement such as: 'Let x be the number of ...' The pronumeral will often represent what you have been asked to find.
 - Highlight the key pieces of information in the question.
 - Write an equation that links the facts in the question using your defined pronumeral.
 - Solve the equation using algebra.
 - Answer the question in words.

Exercise 31

Understanding

1–3

3

1 Match the written scenario with its possible equation.

- | | |
|---|-----------------------------|
| a 7 is 3 more than a number | i $3x + 1 = 16$ |
| b 2 less than a number is 10 | ii $\frac{a}{2} = 3$ |
| c 16 is 1 more than 3 lots of a number | iii $n + 3 = 7$ |
| d Half of a number is 3 | iv $y - 2 = 10$ |

- 2 Arrange the following steps in order when solving a word problem using algebra.
- Solve the equation.
 - Read the problem.
 - Answer the question in words.
 - Set up an equation connecting the facts in the question using the defined variable.
 - Define a pronumeral to represent the unknown.

- 3 The sum of the ages of Sam and his brother Bernard is 34. If Sam is 4 years older than Bernard, fill in the following to find their ages.

Let x be the of Bernard.

The age of Sam is .

The sum of their ages is 34.

$$\therefore x + \text{} = 34$$

$$\text{} + 4 = 34$$

$$2x = \text{}$$

$$x = \text{}$$

\therefore Bernard is years old and Sam is years old.

Hint: Start by underlining the key information.



Fluency

4–8

5–9



Example 24 Turning a word problem into an equation

Five less than three times a certain number is 13. Write an equation and solve it to find the number.

Solution

Let x be the number.

$$3x - 5 = 13$$

$$3x = 18$$

$$x = 6$$

The number is 6.

$$\text{Check: } 3 \times (6) - 5 = 13$$

Explanation

Define the unknown using a pronumeral.

Interpret the wording bit by bit to construct the equation.

3 times the number is $3x$, 5 less than this is $3x - 5$ and this equals 13.

Solve the equation by adding 5 to both sides, then dividing both sides by 3.

Write the answer in words and check your solution.

Now you try

Four more than five times a certain number is 29. Write an equation and solve it to find the number.

- 4 Write an equation and solve it to find the unknown number in the following.
- 4 less than 2 times a number is 10.
 - When a certain number is doubled, it results in a number that is 5 more than the original number.
 - I think of a number, divide it by 3 and add 5. The result is 12.
 - I think of a number, take away 2 and multiply the result by 4. This gives 24.
 - 3 less than a certain number is 9 less than 4 times the number.

31



Example 25 Applying algebra to a word problem

A bicycle shop hires out bikes. It charges an initial fee of \$10 for hiring a bike and then \$8 per hour. Leah returns her bike and is charged \$42. For how many hours did she hire the bike?

Solution

Let h be the number of hours of hire.

$$10 + 8h = 42$$

$$8h = 32$$

$$h = 4$$

\therefore Leah had the bike for 4 hours.

Explanation

Define the unknown value using a pronumeral.

Write an equation from the information: the cost is \$10 plus \$8 per hour ($8 \times h$), which equals \$42.

Solve the equation for h .

Answer the question in words.

Now you try

A babysitter, Jess, charges an initial fee of \$20 and then \$15 per hour. If Jess earns \$95, for how many hours did she babysit?

- 5 Toby rented a car for a total cost of \$290. The rental company charged \$40 per day, plus a hiring fee of \$50.
- Define a pronumeral for the number of days Toby rented the car.
 - Write an equation in terms of your pronumeral in part **a** to represent the problem.
 - Solve the equation in part **b** to find the unknown value.
 - For how many days did Toby rent the car?
- 6 A jeweller earns a weekly amount of \$200 plus \$10 per item she sells. If in one week she earned \$680, how many items did she sell?

Hint: What will you define your pronumeral as?



Example 26 Solving word problems with more complex equations

David and Usman made 254 runs between them in a cricket match. If Usman made 68 more runs than David, how many runs did each of them make?

Solution

Let the number of runs for David be r .

Number of runs Usman made is $r + 68$.

$$r + (r + 68) = 254$$

$$2r + 68 = 254$$

$$2r = 186$$

$$r = 93$$

David made 93 runs and Usman made

$$93 + 68 = 161 \text{ runs.}$$

Explanation

Define the unknown value as a pronumeral.

Write all other unknown values in terms of r .

Usman made 68 more runs than David: $r + 68$.

Write an equation: number of runs for David + number of runs for Usman = 254.

Collect like terms then solve the equation.

Answer the question in words.

Now you try

Max and Tim kicked 11 goals between them in a football match. If Tim kicked 3 more goals than Max, how many goals did each of them kick?

- 7** Leonie and Emma scored 28 goals between them in a netball match. Leonie scored 8 more goals than Emma.
- Define a pronumeral for the number of goals scored by Emma.
 - Write the number of goals scored by Leonie in terms of the pronumeral in part **a**.
 - Write an equation in terms of your pronumeral to represent the problem.
 - Solve the equation in part **c** to find the unknown value.
 - How many goals did each of them score?
- 8** A rectangle is four times as long as it is wide and its perimeter is 560 cm.
- Define a pronumeral for the unknown width.
 - Write an expression for the length in terms of your pronumeral in part **a**.
 - Write an equation involving your pronumeral and the perimeter to represent the problem.
 - Solve the equation in part **c**.
 - What is the length and width of the rectangle?
- 9** A prize of \$1000 is divided between Adele and Benita so that Adele receives \$280 more than Benita. How much did each person receive?

Hint: Draw and label a rectangle to help.



Problem-solving and reasoning

10–12

11–14

- 10** Andrew, Brenda and Cammi all work part-time at a supermarket. Cammi earns \$20 more than Andrew's wage. Brenda earns \$30 less than twice Andrew's wage. If their total combined wage is \$400, find how much each of these workers earns.



- 11** Ed walked a certain distance, and then ran twice as far as he walked. He then caught a bus for the last 2 km. If he travelled a total of 32 km, find how far Ed walked and ran.
- 12** Kate is three times as old as her son. If Kate is 30 years older than her son, what are their ages?

Hint: Remember to follow these steps

- Define a pronumeral for the unknown.
- Set up an equation using the information from the question.
- Solve the equation.
- Answer the question in words.



31

- 13 Two paddocks in the shapes shown below are to be fenced with wire. If the same total amount of wire is used for each paddock, what are the side lengths of each paddock, in metres?

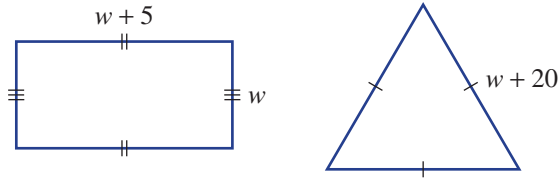
Hint: Solve for w first.

- 14 Consecutive integers can be represented algebraically as x , $x + 1$, $x + 2$ etc.
- Find three consecutive numbers that add to 84.
 - Write three consecutive even numbers starting with x .
 - Find three consecutive even numbers that add to 18.

Hint: Make sure that you are still setting up an equation.



Profit and revenue

—

15

- 15 Tedco produces a teddy bear which sells for \$24. Each teddy bear costs the company \$8 to manufacture and there is an initial start-up cost of \$7200.
- Write a rule for the total cost, T , of producing x teddy bears.
 - If the cost of a particular production run was \$9600, how many teddy bears were manufactured in that run?
 - If x teddy bears are sold, write a rule for the revenue, R , received by the company.
 - How many teddy bears were sold if the revenue was \$8400?
 - If they want to make an annual profit of \$54 000, how many teddy bears do they need to sell?

Hint: Revenue is the total amount of money collected. Profit is the amount left over from the revenue after the costs have been taken out.
Profit = revenue – costs



3J Using formulas

Learning intentions

- To know which variable is the subject of a formula
- To be able to work with a formula by substituting known values
- To be able to find the unknown value in a formula by solving an equation
- To be able to transpose a formula to make a different variable the subject

Key vocabulary: subject, formula, variable, substitute, transpose, equation

A formula (or rule) is an equation that relates two or more variables. You can find the value of one of the variables if you are given the value of all other unknowns. The following are some examples of formulas.

- $A = \pi r^2$ is the formula for finding the area, A , of a circle given its radius, r .
- $V = lwh$ is the formula for finding the volume of a rectangular prism given its length, l , width, w , and height, h .
- $F = \frac{9}{5}C + 32$ is the formula for converting degrees Celsius, C , to degrees Fahrenheit, F .



A , V and F are said to be the subjects of the formulas given above.

Lesson starter: Common formulas

As a class group, try to list at least 10 formulas that you know.

- Write down the formulas.
- Try to describe what each variable in your formulas represents.
- Which variable is the subject of each formula?

Key ideas

- A **formula** is a rule for finding the value of one quantity given the value of the others.
- The **subject** of a formula is a variable that usually sits on its own on the left side.
For example, the A in $A = lw$ is the subject of the formula.
- A variable in a formula can be evaluated by substituting numbers for all other variables.
- If the unknown is not the subject, a simple equation will need solving.
- **Transposing** is when a formula is rearranged to make another variable the subject. Steps are similar to those applied when solving an equation.

$A = lw$ can be transposed (i.e. rearranged) to give $l = \frac{A}{w}$ with l now the subject.

Exercise 3J

Understanding

1–3

3

1 Write down 3 different formulas that you know for the area of shapes.

2 State the letter which is the subject of these formulas.

a $A = \frac{1}{2}bh$ **b** $D = b^2 - 4ac$ **c** $M = \frac{a+b}{2}$ **d** $A = \pi r^2$

Hint: In $V = lwh$, V is the subject.



3 Complete the step given in brackets to transpose the following formulas to make x the subject.

a $ax = b$ (divide both sides by a)

b $\frac{x}{c} = d$ (multiply both sides by c)

c $x - ab = d$ (add ab to both sides)

d $\sqrt{x} = c$ (square both sides)

Hint: Transpose means to make a different variable the subject.



Fluency

4, 5, 6(½)

4–6(½)



Example 27 Substituting values into formulas

Substitute the given values into the formula to find the value of the subject.

a $A = \frac{1}{2}(a+b)h$, when $a = 3$, $b = 7$ and $h = 5$

b $E = \frac{1}{2}mv^2$, when $m = 4$ and $v = 5$

Solution

Explanation

a $A = \frac{1}{2}(a+b)h$

$$A = \frac{1}{2} \times (3+7) \times 5$$

$$= \frac{1}{2} \times 10 \times 5$$

$$= 25$$

Substitute $a = 3$, $b = 7$ and $h = 5$. Work out the sum in the brackets first, then multiply out to find the value of A .

b $E = \frac{1}{2}mv^2$

$$E = \frac{1}{2} \times 4 \times 5^2$$

$$= \frac{1}{2} \times 4 \times 25$$

$$= 50$$

Substitute $m = 4$ and $v = 5$. $5^2 = 5 \times 5 = 25$, then work out E by multiplying.

Now you try

Substitute the given values into the formula to find the value of the subject.

a $M = \frac{a+b}{2}$, when $a = 5$ and $b = 9$

b $F = \frac{mn}{r^2}$, when $m = 12$, $n = 6$ and $r = 3$



- 4 Substitute the given values into each of the following formulas to work out the subject. Round to two decimal places where appropriate.
- a** $A = bh$, when $b = 3$ and $h = 7$
- b** $F = ma$, when $m = 4$ and $a = 6$
- c** $m = \frac{a+b}{4}$, when $a = 14$ and $b = -6$
- d** $t = \frac{d}{v}$, when $d = 18$ and $v = 3$
- e** $A = \pi r^2$, when $r = 12$
- f** $V = \frac{4}{3}\pi r^3$, when $r = 2$
- g** $c = \sqrt{a^2 + b^2}$, when $a = 12$ and $b = 22$
- h** $Q = \sqrt{2gh}$, when $g = 9.8$ and $h = 11.4$
- i** $I = \frac{MR^2}{2}$, when $M = 12.2$ and $R = 6.4$
- j** $x = ut + \frac{1}{2}at^2$ when $u = 0$, $t = 4$ and $a = 10$



Example 28 Finding the unknown value in a formula

Substitute the given values into each formula, then solve to find the unknown value. Round to one decimal place in part **b**.

a $S = \frac{d}{t}$ given $S = 15$ and $d = 60$

b $C = 2\pi r$ given $C = 30$

Solution

Explanation

a $S = \frac{d}{t}$

$$15 = \frac{60}{t}$$

$$15t = 60$$

$$t = 4$$

b $C = 2\pi r$

$$30 = 2\pi r$$

$$\frac{30}{2\pi} = r$$

$$r = 4.8 \text{ (to 1 d.p.)}$$

Write the formula and substitute the given values of S and d .

Solve for t by first multiplying both sides by t .

Divide both sides by 15.

Substitute $C = 30$. Solve for r by dividing both sides by 2π in one step. $\frac{30}{2\pi} = 4.77464\dots$

Note: On a calculator you will need to insert brackets, $30 \div (2\pi)$, or set up using the fraction template, $\frac{\square}{\square}$.

Now you try

Substitute the given values into each formula, then solve to find the unknown value. Round to one decimal place in part **b**.

a $R = \frac{pl}{A}$ given $R = 16$, $p = 6$ and $l = 8$

b $S = 2\pi rh$ given $S = 100$ and $h = 5$



- 5 Substitute the given values into each of the following formulas. Solve the equations to find the unknown value. Round to two decimal places where appropriate.
- a** $m = \frac{F}{a}$, when $m = 12$ and $a = 3$
- b** $A = lw$, when $A = 30$ and $l = 6$
- c** $v = u + at$, when $v = 20$, $u = 5$ and $a = 2$
- d** $p = \frac{m}{v}$, when $p = 2$ and $m = 50$
- e** $A = \pi r^2$, when $A = 48$ and $(r > 0)$
- f** $A = \frac{1}{2}(a + b)h$, when $A = 64$, $b = 12$ and $h = 4$

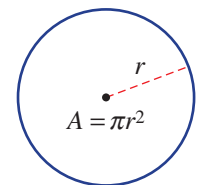

3J



Example 29 Transposing formulas

Transpose each of the following to make the variable in red the subject.

a $ax + by = c$

b $A = \pi r^2$ ($r > 0$)

Solution

Explanation

a $ax + by = c$

$$by = c - ax$$

$$y = \frac{c - ax}{b}$$

We need to obtain y on one side by itself. Follow steps as if you are solving the equation for y .

Subtract ax from both sides.

by is $b \times y$. Just as for $2y$ you would divide both sides by 2, divide both sides by b .

b $A = \pi r^2$

$$\frac{A}{\pi} = r^2$$

$$r^2 = \frac{A}{\pi}$$

$$r = \sqrt{\frac{A}{\pi}}$$

Divide both sides by π .

Make r^2 the subject.

Take the square root of both sides, since $\sqrt{r^2} = r$ if $r > 0$.

Now you try

Transpose each of the following to make the variable in red the subject.

a $v = u + at$

b $E = \frac{mv^2}{2}$, $v > 0$

6 Transpose each of the following formulas to make the pronumeral in red the subject.

a $C = \pi d$

b $a + bx = d$

c $p = m(x + n)$

d $I = \frac{Prt}{100}$

e $P = \frac{v^2}{R}$ ($v > 0$)

f $A = 2\pi rh$

g $V = \pi r^2 h$ ($r > 0$)

h $\sqrt{A} + B = 4C$

i $c^2 = a^2 + b^2$ ($a > 0$)

j $\sqrt{b+c} = a$

Hint: Follow similar steps as if you were solving to find the letter in red, such as $d = \dots$



Problem-solving and reasoning

7, 8

8–10



7 The formula $s = \frac{d}{t}$ gives the speed s km/h of a car which has travelled a distance of d km in t hours.

a Find the speed of a car which has travelled 400 km in 4.5 hours. Round to two decimal places.

b i Transpose the formula $s = \frac{d}{t}$ to make d the subject.

ii Find the distance covered if a car travels at 75 km/h for 3.8 hours.



8 The velocity, v m/s, of an object is described by the rule $v = u + at$, where u is the initial velocity in m/s, a is the acceleration in m/s^2 and t is the time in seconds.

- a** Find the velocity after 3 seconds if the initial velocity is 5 m/s and the acceleration is 10 m/s^2 .
b Find the time taken for a body to reach a velocity of 20 m/s if its acceleration is 4 m/s^2 and its initial velocity is 12 m/s.

Hint: Write down the value of the known variables first; i.e. $t = 3$, $u = 5$ etc.



Hint: Velocity is another word for speed.



9 The volume of water (V litres) in a tank is given by $V = 4000 - 0.1t$, where t is the time in seconds after a tap is turned on.

- a** Over time, does the water volume increase or decrease according to the formula?
b Find the volume after 2 minutes. (Note: t is in seconds.)
c Find the time it takes for the volume to reach 1500 litres. Round to the nearest minute.

10 The formula $F = \frac{9}{5}C + 32$ converts degrees Celsius, C , to degrees Fahrenheit, F .

- a** Find what each of the following temperatures is in degrees Fahrenheit.
i 100°C **ii** 38°C
b Calculate what each of the following temperatures is in degrees Celsius. Round to one decimal place where necessary.
i 14°F **ii** 98°F

Hint: $\frac{9}{5}C$ can also be written as $\frac{9C}{5}$.



Basketball formulas

—

11

11 The formula $T = 3x + 2y + f$ can be used to calculate the total number of points made in a basketball game where:

x = number of three-point goals
 y = number of two-point goals
 f = number of free throws made
 T = total number of points

- a** Find the total number of points for a game where 12 three-point goals, 15 two-point goals and 7 free throws were made.
b Find the number of three-point goals made if the total number of points was 36, with 5 two-point goals made and 5 free throws made.

The formula $V = \frac{\left(p + \frac{1.5r}{2} + 2a + \frac{1.5s}{2} + 2b\right) - (1.5t + 2f + m - o)}{g}$ can be used to calculate the

value, V , of a basketball player where:

p = points earned r = number of rebounds
 a = number of assists s = number of steals
 b = number of blocks t = number of turnovers
 f = number of personal fouls m = number of missed shots
 o = number of offensive rebounds g = number of games played

- c** Calculate the value of a player with 350 points earned, 2 rebounds, 14 assists, 25 steals, 32 blocks, 28 turnovers, 14 personal fouls, 24 missed shots, 32 offensive rebounds and 10 games.



Maths@Work: Plumber

Plumbers use many skills in their day-to-day jobs. The training course is up to 5 years of on-the-job experience via an apprenticeship and TAFE courses.

Mathematics is an important skill for a plumber. They measure, cut, bend and connect pipes according to project specifications. Equations and formulas play an important role in the life of a plumber, especially if working on big construction sites as calculations need to be accurate for buildings to satisfy Australian regulations.



- 1 Water expands when heated. Plumbers need to allow for this additional volume when selecting the most suitable water storage unit for a project. The volume E (litres) of water expansion is calculated with this formula:

$$E = L \times (T - t) \times 0.000375 \text{ where}$$

L = initial volume of water in litres

T = highest temperature in $^{\circ}\text{C}$

t = lowest temperature in $^{\circ}\text{C}$

0.000375 is the coefficient of expansion for water.

Calculate the volume of water expansion in litres (to 2 d.p.) that would occur when:

- 600 L of water is heated from 22° to 50°
 - 500 L of water is heated from 18° to 60°
 - 1000 L of water is heated from 20° to 70°
 - 800 L of water increased in temperature by 50°
- 2 Plumbers need to calculate water pressure, P , measured in kPa (kilopascals) for any given height, h (m), above an outlet. The following formula is used:

$$P = h \times 9.81 \text{ where } 9.81 \text{ is the gravitational pressure exerted by } 1 \text{ m height of water.}$$

- Calculate the water pressure for a pressure head of:
 - 10 m
 - 20 m
 - 30 m
 - 40 m
- Rewrite the above formula with h as the subject and calculate how many metres (to 2 d.p.) of water are in a non-pressurised tank if the pressure gauge reads:
 - 24.6 kPa
 - 24.1 kPa
 - 13.5 kPa
 - 27.9 kPa

- 3 A plumber needs to install the pipes that connect a house to the underground mains water supply and to the council sewage disposal system. Water flows under pressure up to the house and the sewerage pipe is sloped downwards to allow waste to flow away under the force of gravity. The difference in level between each end of a sloping pipe is called the fall measurement.



$$\text{Fall (mm)} = \frac{\text{pipe length in mm} \times x}{100}, \text{ where the gradient } x\% = \text{the fall in mm per } 100 \text{ mm of pipe.}$$

Calculate the total fall in mm required to install the following pipes. Round to the nearest mm.

- a A water pipe is 6 m long and installed at a 2.5% gradient.
- b A water pipe is 17 m long and installed at a 2.1% gradient.
- c A sewerage pipe is 9 m in length installed at a 1.67% gradient.
- d A sewerage pipe is 18 m in length installed at a 1.85% gradient.

Using technology

- 4 The number of downpipes required for a house depends on the roof area and the size of the downpipes. Each size of downpipe can drain a maximum area of roof. The number of downpipes needed can be estimated using the rain catchment area of a roof, which is the equivalent flat area of the roof, not the actual sloping area.

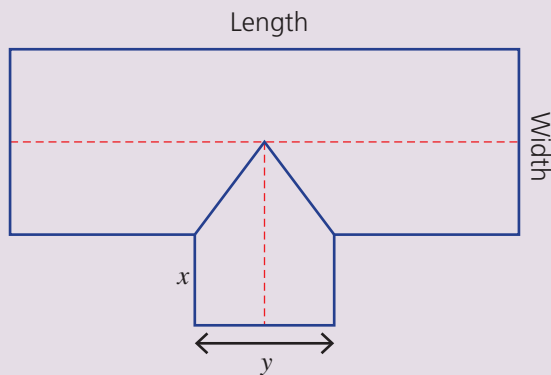

$$\text{Number of downpipes} = \frac{\text{total roof catchment area}}{\text{maximum area per downpipe}}$$

Set up an Excel spreadsheet as shown below. Use the given roof dimensions applied to the roof plan above and determine the number of downpipes required for each house.

Hint: The whole number of downpipes is manually determined by rounding up the decimal number of downpipes.



	A	B	C	D	E	F	G	H	I
1	The number of downpipes for a house								
2	House	Length m	Width m	x m	y m	Total roof catchment area in m ²	Maximum area in m ² per downpipe	Decimal number of downpipes	Whole number of downpipes
3	i	14	8.5	4	3		47		
4	ii	15	9	3	4		45		
5	iii	17	10	3	3.5		46		
6	iv	22	11	3	5		47		

Theme Parks

Theme parks and amusement parks all over the world offer a vast array of exhilarating and thrilling rides, such as Buzzsaw and The Giant Drop.

Hugo and Alice live near two theme parks called Extreme Thrill and Adventure World. They plan to run tourist bus trips to the theme parks and want to advertise the best deal at each theme park depending on the number of rides.

The theme parks charge different entry prices and cost for each ride.

Theme park	Entry cost	Fee per ride
Extreme Thrill	\$42	\$3
Adventure World	\$30	\$5

Present a report for the following tasks and ensure that you show clear mathematical workings, explanations and diagrams where appropriate.

Preliminary task

Tickets are bought at the entry for a certain number of rides.

- a Find the cost of a ticket at Extreme Thrill for
 - i 4 rides
 - ii 10 rides
- b Find the cost of a ticket at Adventure World for
 - i 4 rides
 - ii 10 rides

Modelling task

The problem is to determine the cheapest theme park depending on the number of rides taken.

- a Write down all the relevant information that will help solve this problem.
 - b Let T = total ticket price and n = number of rides.
Construct a formula for the total ticket price T for n rides at
 - i Extreme Thrill
 - ii Adventure World
-
- c Hugo spends \$75 for a ticket into Extreme Thrill.
 - i Write the formula for the ticket price T , for n rides at Extreme Thrill.
 - ii Set up an equation by substituting $T = 75$
 - iii Solve this equation algebraically for n .
 - iv How many rides were included in Hugo's \$75 ticket?
 - d Alice spends \$75 for a ticket into Adventure World.
 - i Write the formula for the ticket price T , for n rides at Adventure world.
 - ii Set up an equation by substituting $T = 75$
 - iii Solve this equation algebraically for n .
 - iv How many rides were included in Alice's \$75 ticket?
 - e Compare your answers to **c** and **d** above, and state which theme park offers the best deal for a \$75 ticket. Give a reason for your answer.
 - f Hugo and Alice buy 2 identical tickets for Extreme Thrill costing a total of \$138.
 - i Write the formula for 2 Extreme Thrill tickets and form an equation by substituting $T = 138$.
 - ii Solve this equation for n and state how many rides they each paid for.

Formulate

Solve

- g** Hugo decides to calculate the number of rides that make the ticket prices equal at each theme park.
- Set up the equation by equating the ticket price formulas.
i.e. Extreme Thrill ticket formula = Adventure World ticket formula
 - Solve this equation algebraically for n .
 - For how many rides does each theme park have the same ticket price?
 - Calculate this ticket price for each theme park.

- h** For how many rides is Extreme Thrill the cheaper option? Justify your answer with a mathematical calculation.
- i** For how many rides is Adventure world the cheaper option? Justify your answer with a mathematical calculation.

Evaluate
and
verify

- j** Summarise your results using a table like the one below and describe any key findings.

Ticket prices							
Number of rides n							
Extreme Thrill							
Adventure world							

Communicate

Extension questions

A new theme park called Monster Rides charges \$22 entry plus \$7 per ride.

- Construct a formula for the total ticket price T for n rides at Monster Rides.
- Set up equations by equating ticket price formulas and then solve each equation to find the number of rides n that make the Monster Rides ticket price equal to the:
 - Extreme Thrill ticket price
 - Adventure World ticket price
- If, on average, people buy tickets for 7 or more rides, which theme park out of the three, would be expected to make the largest profit? Justify your answer with some mathematical calculations.



- 1 In a magic square, all the rows, columns and main diagonals add to the same total. The total for this magic square is 15. Find the value of x then complete the magic square.

$2x - 2$	$3x$	$x - 1$
x		

- 2 Simplify $2xy - 3x(y - 2x) - 8x^2y \div (2y) + 2x \times 6xy \div (4y)$.
- 3 Reveal the word below by solving each equation for x . The value of x gives the number of the letter in the alphabet; e.g. $x = 1$ would be *A*, $x = 2$ would be *B* etc.



$$\frac{x-3}{4} = 5$$

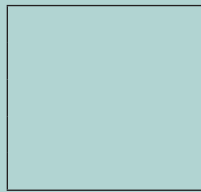

$$6x = 4x + 30$$

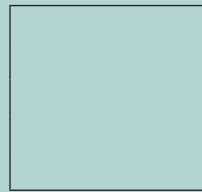

$$2(x - 10) = 16$$

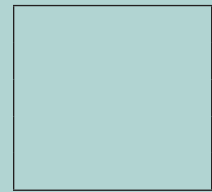

$$1 - 2x = -7$$

- 4 Twelve years ago Eric's father was seven times as old as Eric was. If Eric's father is now 54 years old, how old is Eric now?
- 5 In a yacht race the second leg was half the length of the first leg. The third leg was two-thirds of the length of the second leg. The last leg was twice the length of the second leg. If the total distance was 153 km, find the length of each leg.



- 6 A group of office workers had some prize money to distribute among themselves. When all but one took \$9 each, the last person only received \$5. When they all took \$8 each, there was \$12 left over. How much had they won?
- 7 Try finding a solution to these more complex linear equations.

a $\frac{x}{3} + \frac{x}{2} = 2$

b $\frac{x+1}{5} - \frac{x-1}{7} = 1$

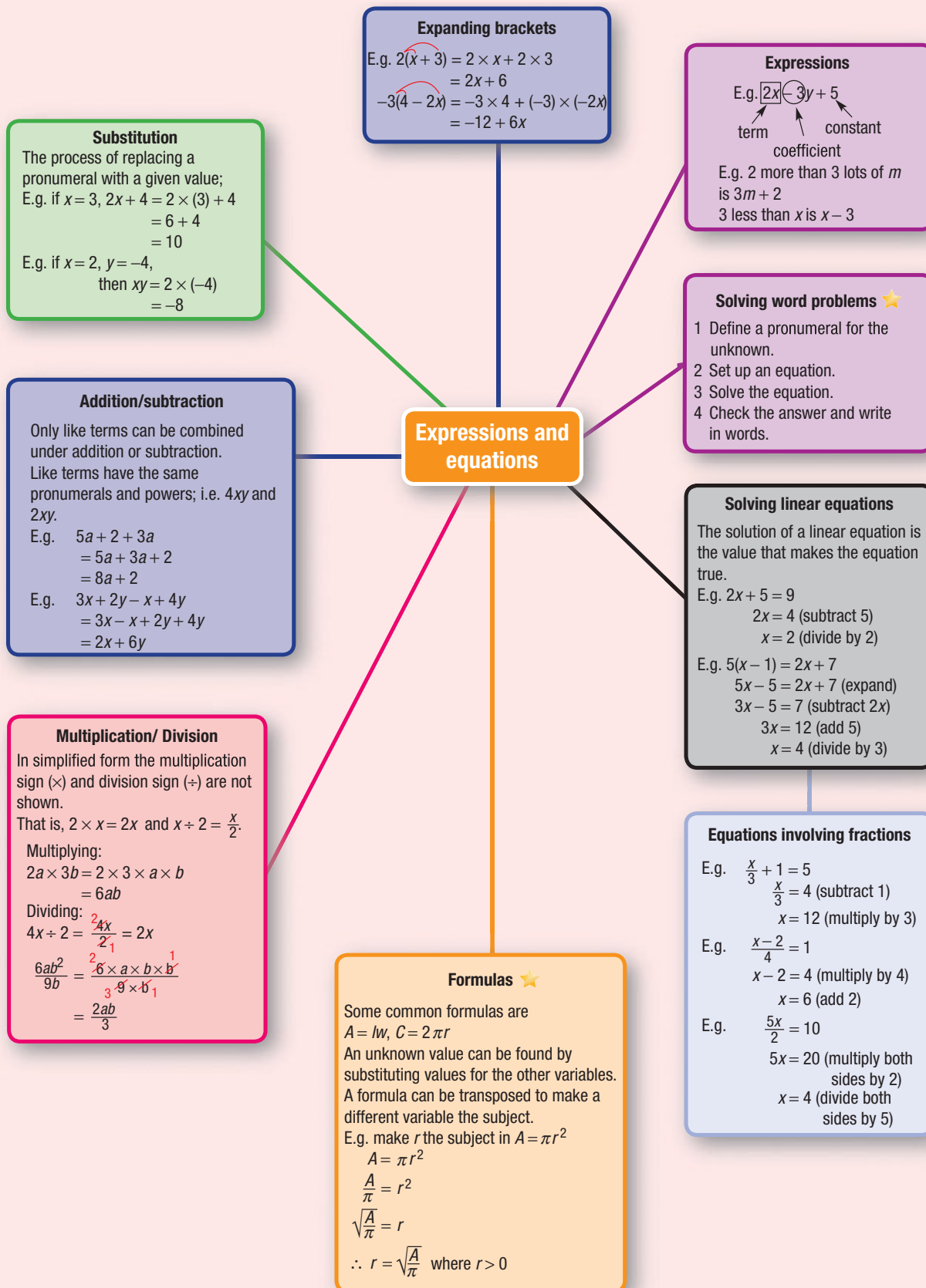

Chapter checklist

A version of this checklist that you can print out and complete can be downloaded from your Interactive Textbook.

3A	<p>1 I can identify parts of an algebraic expression. e.g. Consider the expression $3x - 5y + 6$. State:</p> <p>a the number of terms b the coefficient of y c the constant term</p>	✓
3A	<p>2 I can convert words and word problems to expressions. e.g. Write an algebraic expression for</p> <p>a the cost of n movie tickets at \$15 each b four less than three times x c the square of y is divided by 4</p>	
3A	<p>3 I can substitute values into expressions and evaluate. e.g. Evaluate these expressions if $p = -4$, $q = 6$ and $r = 5$:</p> <p>a $4q - r$ b $3p - (q + r)$</p>	
3B	<p>4 I can identify like terms. e.g. Choose the pair(s) of like terms from the following set: $4x, 5, 3xy, -5x, 2xy^2, yx$</p>	
3B	<p>5 I can collect like terms. e.g. Simplify the following by collecting like terms:</p> <p>a $5a - 4 + 3a$ b $4xy + 6y - xy + 4y$</p>	
3C	<p>6 I can multiply algebraic terms. e.g. Simplify the following:</p> <p>a $4s \times 5t$ b $-3y \times 8xy$</p>	
3C	<p>7 I can divide algebraic terms. e.g. Simplify the following:</p> <p>a $\frac{15x}{12}$ b $16a^2b \div (24ab)$</p>	
3D	<p>8 I can expand expressions with brackets. e.g. Expand the following and simplify:</p> <p>a $4(x + 5)$ b $-3(x - 6)$ c $2x(3x - y)$</p>	
3D	<p>9 I can expand and collect like terms. e.g. Expand the following and collect like terms:</p> <p>a $3(x + 2) - 4$ b $5 - 2(x + 1)$</p>	
3E	<p>10 I can solve simple linear equations. e.g. Solve the following equations:</p> <p>a $2x - 5 = 7$ b $8 - 3x = 15$</p>	
3F	<p>11 I can solve linear equations with fractional coefficients. e.g. Solve each of the following equations</p> <p>a $\frac{3x}{4} = 9$ b $\frac{x}{5} - 4 = 2$</p>	



Chapter checklist

3F	<p>12 I can solve simple fractional equations. e.g. Solve the equation $\frac{x-5}{3} = 6$</p>	✓
3G	<p>13 I can solve equations with brackets. e.g. Solve $3(3x+5) = 22$</p>	
3G	<p>14 I can solve equations with brackets and a common factor. e.g. Solve $4(2x+3) = 32$ by first dividing by the common factor</p>	
3G	<p>15 I can solve equations with brackets and like terms. e.g. Solve $2(4x+7) - 5x = 20$</p>	
3H	<p>16 I can solve equations with pronumerals on both sides. e.g. Solve these equations: a $8x = 3x + 25$ b $10 - 3x = x + 2$</p>	
3H	<p>17 I can solve equations with brackets and pronumerals on both sides. e.g. Solve $4(2x-1) = 2(x-8)$</p>	
3I	<p>18 I can turn a word problem into an equation. e.g. 8 more than two times a certain number is 30. Write an equation and solve it to find the number.</p>	
3I	<p>19 I can apply algebra to a word problem. e.g. A surf shop hires out surfboards. It charges an initial fee of \$15 for hiring a board and then a charge of \$12 per hour. Jett returns his board and is charged \$51. For how many hours did he hire the board?</p>	
3I	<p>20 I can solve more complex word problems. e.g. Toni and Trey earn \$370 between them walking dogs. If Toni earned \$140 more than Trey, how much money did each of them make?</p>	
3J	<p>21 I can substitute values into formulas and find the unknown. e.g. Substitute the given values into the formula to find the value of the unknown. Round to one decimal place where necessary. a $A = \frac{1}{2}xy$ when $x = 7$ and $y = 10$ b $V = \pi r^2 h$ when $V = 120$ and $r = 3$</p>	
3J	<p>22 I can transpose a formula. e.g. Transpose the formula $v^2 = u^2 + 2as$ to make u the subject ($u > 0$).</p>	

Short-answer questions

- 3A 1** Write algebraic expressions to represent the following.
- The sum of x and y
 - The product of m and 7
 - The cost of 3 movie tickets at m dollars each
 - 3 less than n , all divided by 4
- 3A 2** Evaluate the following if $x = 2$, $y = -1$ and $z = 5$.
- $xz + 1$
 - $4x + y$
 - $x - 2yz$
 - $x(y + z)$
 - $x^2 - 3z$
- 3C 3** Simplify.
- $2 \times 4n$
 - $3x \times 2y$
 - $8a \div 2$
 - $\frac{4x^2y}{12x}$
- 3B 4** Simplify by collecting like terms.
- $2b + 4b + b$
 - $6x + 3 - 2x$
 - $4p - 3q - p + 5q$
 - $3mn + 2m - 6mn + n$
- 3D 5** Expand and simplify the following.
- $2(x + 7)$
 - $-3(2x + 5)$
 - $2x(3x - 4)$
 - $-2a(5 - 4a)$
 - $4(x + 2) + 5$
 - $3(x - 2) - 1$
- 3E 6** Solve the following linear equations for x .
- $5x + 6 = 51$
 - $7x - 4 = 10$
 - $4 - x = 7$
 - $3 - 2x = 21$
- 3F 7** Solve these linear equations involving fractions.
- $\frac{2x}{5} = 4$
 - $\frac{x}{2} - 1 = 3$
 - $\frac{x+2}{4} = 7$
 - $\frac{1}{3}x + 2 = 4$
- 3I 8** Write an equation to represent each of the following and then solve it for the pronumeral.
- A number, n , is doubled and increased by 3 to give 21.
 - A number of lollies, l , is decreased by 5 and then shared equally among 3 friends so that they each get 7.
 - 5 less than the result of Toni's age, x , divided by 4 is 0.
- 3G 9** Solve the following linear equations by first expanding the brackets.
- $2(x + 4) = 18$
 - $3(2x - 3) = 2$
- 3H 10** Solve these equations with variables on both sides.
- $8x = 2x + 24$
 - $5x - 2 = 3x + 2$
 - $3 - 4x = 7x - 8$
 - $5(2x + 4) = 7x + 5$
- 3I 11** Nick makes an initial bid of $\$x$ in an auction for an old cricket bat. By the end of the auction he has paid $\$550$, which is $\$30$ more than twice his initial bid, x . Set up and solve an equation to determine Nick's initial bid.
- 3J 12** Find the value of the unknown in each of the following formulas.
- $E = \sqrt{PR}$ when $P = 90$ and $R = 40$
 - $v = u + at$ when $v = 20$, $u = 10$, $t = 2$
 - $V = \frac{1}{3}Ah$ when $V = 20$, $A = 6$
- 3J 13** Rearrange the following formulas to make the variable in brackets the subject.
- $v^2 = u^2 + 2ax$ (x)
 - $P = RI^2$, $I > 0$ (I)

Multiple-choice questions

- 3A** 1 The algebraic expression that represents 2 less than 3 lots of n is:
A $3(n - 2)$ **B** $2 - 3n$ **C** $3n - 2$ **D** $3 + n - 2$ **E** n
- 3C** 2 The fully simplified form of $2ab \div (8a)$ is:
A $\frac{2ab}{8a}$ **B** $\frac{4}{b}$ **C** $\frac{b}{4}$ **D** $4b$ **E** $4a$
- 3B** 3 The simplified form of $6ab + 14a - 2ab + 3a$ is:
A $21ab$ **B** $4ab + 11a$ **C** $ab + 7a$ **D** $4ab + 17a$ **E** $4 + 17a$
- 3E** 4 The solution to the equation $2x - 3 = 7$ is:
A $x = 2$ **B** $x = -5$ **C** $x = 5$ **D** $x = 6.5$ **E** $x = 0.5$
- 3F** 5 The solution to $\frac{x}{3} - 1 = 4$ is:
A $x = 13$ **B** $x = 7$ **C** $x = 9$ **D** $x = 15$ **E** $x = \frac{5}{3}$
- 3D** 6 The expanded form of $3(2y - 1)$ is:
A $6y - 3$ **B** $5y - 1$ **C** $6y - 1$ **D** $6y + 2$ **E** $3y - 3$
- 3H** 7 An equivalent equation to $5x = 2x + 9$ is:
A $2x = 5$ **B** $3x = 9$ **C** $0 = 3x + 9$ **D** $7x = 9$ **E** $x = 9$
- 3G** 8 The solution to the equation $2(x - 3) = 7$ is:
A $x = 5$ **B** $x = \frac{13}{2}$ **C** $x = 2$ **D** $x = \frac{1}{2}$ **E** $x = \frac{7}{3}$
- 3I** 9 Eli is x years old. His sister is 2 years older. The sum of their ages is 22. A simplified equation to represent this is:
A $x + 2 = 22$ **B** $2x + 2 = 22$ **C** $2(x + 2) = 22$ **D** $x(x + 2) = 22$ **E** $2x = 22$
- 3J** 10 If $A = \frac{1}{2}bh$ with $A = 360$ and $h = 40$, then the value of b is:
A 90 **B** 4.5 **C** 20 **D** 18 **E** 9

Extended-response questions

- 1 Julie hires a jumping castle for her daughter's birthday party. It costs \$60 for the set-up, plus \$25 for each hour that it is hired.
- What is the cost for:
 - 1 hour of hire?
 - 2 hours of hire?
 - Julie is charged \$210 for the hire of the jumping castle.
 - Define a variable to represent the number of hours for which Julie hired the castle.
 - Set up an equation using your variable.
 - Solve the equation to find how many hours Julie hired the jumping castle for.

- 2 A new backyard deck is being designed in the shape of the trapezium shown.

The area of a trapezium is given by $A = \frac{1}{2}(a + b)h$.

Currently the dimensions are set such that $a = 12$ m and $b = 8$ m.

- Substitute the given values and rearrange the equation to make h the subject.
- Use your answer to part **a** to find the width of the deck (h m) required to have a deck area of 100 m².
- It is decided to extend the width (h) to 12 m to increase the area to 150 m². If b is fixed at 8 m, find the value of a that gives the required area.

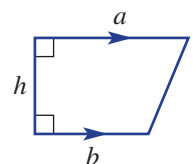

Chapter 4

Pythagoras' theorem and trigonometry

Essential mathematics: why skills with Pythagoras' theorem and trigonometry are important

Pythagoras' theorem and trigonometry are essential skills for the accurate calculations of lengths and angles. These methods are widely applied, including by builders, carpenters, plumbers, electricians, surveyors, navigators, engineers, architects and designers. Everyday users of Pythagoras' theorem and trigonometry include:

- Designers and builders of house frames, roof trusses, verandas or decks, kitchen cabinets, stairs, carports, holiday cabins, awnings and wheel chair ramps.
- Plumbers and electricians who calculate placement angles and lengths of water pipes and conduit (plastic protection tubing for electrical cables).
- Fashion designers who use trigonometry to calculate dart angles in clothing patterns and interior designers who apply trigonometry and geometry for the placement of lamps, furniture and loud speakers.
- Surveyors who calculate the height of mountains and the placement on maps of streets, roads, bridges and buildings.



In this chapter

- 4A Exploring Pythagoras' theorem
- 4B Finding the length of the hypotenuse
- 4C Finding the lengths of the shorter sides
- 4D Applying Pythagoras' theorem ★
- 4E Trigonometric ratios
- 4F Finding side lengths
- 4G Solving for the denominator
- 4H Finding an angle
- 4I Applying trigonometry ★

Australian Curriculum

MEASUREMENT AND GEOMETRY

Pythagoras and trigonometry

Investigate Pythagoras' Theorem and its application to solving simple problems involving right-angled triangles (ACMMG222)

Use similarity to investigate the constancy of the sine, cosine and tangent ratios for a given angle in right-angled triangles (ACMMG223)

Apply trigonometry to solve right-angled triangle problems (ACMMG224)

© Australian Curriculum, Assessment and Reporting Authority (ACARA)

Online resources

A host of additional online resources are included as part of your Interactive Textbook, including HOTmaths content, video demonstrations of all worked examples, auto-marked quizzes and much more.

1 What is the length of the longest side given on these triangles?

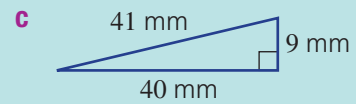
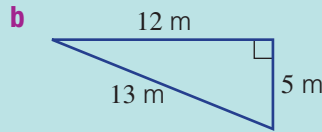
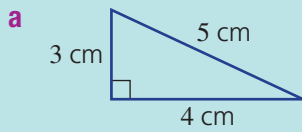

2 Calculate each of the following.

a 3^2

b 7^2

c $2^2 + 4^2$

d $9^2 - 6^2$

3 Round off each number correct to four decimal places.

a 0.45678

b 0.34569

c 0.04562

d 0.27997

4 Round off each number correct to two decimal places.

a 4.234

b 5.678

c 76.895

d 23.899

 5 Use a calculator to calculate each of the following correct to two decimal places.

a $\sqrt{35}$

b $\sqrt{236}$

c $\sqrt{23.6}$

d $\sqrt{65.4}$

6 Find the value of x in these diagrams.

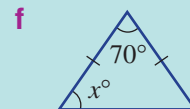
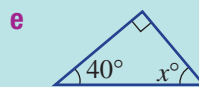
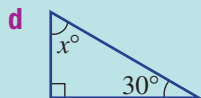
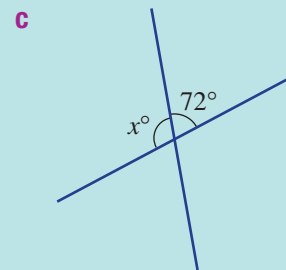
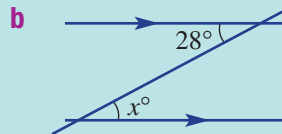
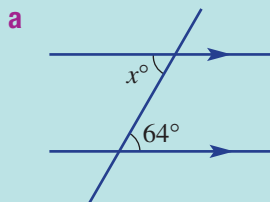

7 Solve each of the following equations to find the value of x . Multiply or divide both sides to start.

a $3x = 6$

b $4x = 12$

c $5x = 60$

d $8x = 48$

e $\frac{x}{3} = 4$

f $\frac{x}{5} = 6$

g $\frac{x}{7} = 4$

h $\frac{x}{13} = 14$

 8 Solve each of the following equations to find the value of x correct to one decimal place. First multiply both sides by x , then divide to finish.

a $\frac{3}{x} = 5$

b $\frac{4}{x} = 7$

c $\frac{32}{x} = 15$

d $\frac{14}{x} = 27$

9 Given that x is a positive number, find its value in each of the following equations. Note, for example, that if $x^2 = 9$ then $x = \sqrt{9} = 3$ (provided that $x > 0$).

a $x^2 = 4$

b $x^2 = 16$

c $x^2 = 3^2 + 4^2$

d $x^2 = 12^2 + 5^2$

4A Exploring Pythagoras' theorem

Learning intentions

- To know which side of a right-angled triangle represents the hypotenuse
- To know that Pythagoras' theorem relates to right-angled triangles
- To know the relationship between the square of the sides of a right-angled triangle (Pythagoras' theorem)
- To be able to write Pythagoras' theorem for a triangle using variables or numbers

Key vocabulary: hypotenuse, Pythagoras' theorem, right-angled, square

The philosopher Pythagoras was born in Greece in the 6th century BCE. He travelled to Egypt and Persia where he developed his ideas in mathematics and philosophy. His students and followers were called the Pythagoreans. They made many advances in mathematics.

The Pythagoreans discovered the famous theorem, which is named after Pythagoras, and the existence of irrational numbers such as $\sqrt{2}$, which cannot be written down as a fraction or terminating decimal. The Pythagoreans called these numbers 'unutterable' numbers because any member who mentioned these numbers in public might be put to death.



→ Lesson starter: Discovering Pythagoras' theorem

Use a ruler to measure the sides of these right-angled triangles to the nearest mm. Then complete the table.

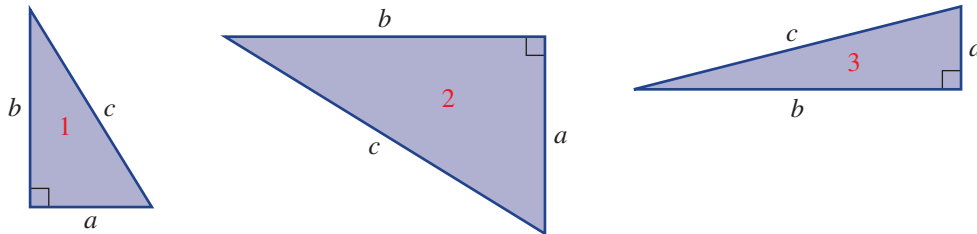

Triangle	a	b	c	a^2	b^2	c^2
1						
2						
3						

- Can you see any relationship between the numbers in the columns for a^2 and b^2 and the number in the column for c^2 ?
- Can you write down this relationship as an equation?
- Explain how you might use this relationship to calculate the value of c if it was unknown.
- Research how you can cut the two smaller squares (a^2 and b^2) to fit the pieces into the largest square (c^2).

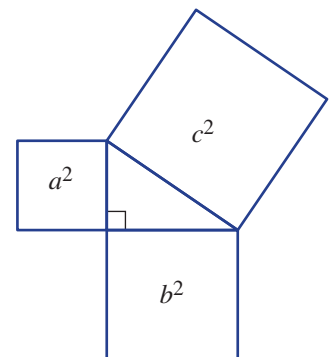

4A

Key ideas

- The **hypotenuse**:
 - is the longest side of a **right-angled** (90°) triangle.
 - is opposite the right angle.
- **Pythagoras' theorem** states:
 - the square of the hypotenuse is equal to the sum of the squares of the other two shorter sides.
 $a^2 + b^2 = c^2$ or $c^2 = a^2 + b^2$

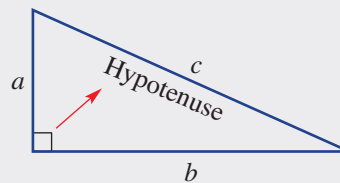

Exercise 4A

Understanding

1–3

3

- 1 Write the missing words in this sentence.
The _____ is the longest side of a right-angled _____.

- 2 Which letter marks the length of the hypotenuse in these triangles?

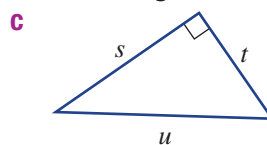
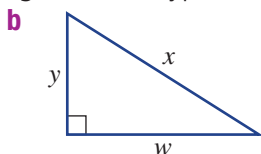
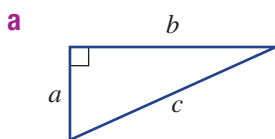

Hint: The hypotenuse is the longest side of a right-angled triangle.



- 3 Decide if these equations are true or false.
a $2^2 + 3^2 = 4^2$ **b** $6^2 + 8^2 = 10^2$ **c** $5^2 - 3^2 = 4^2$ **d** $10^2 - 5^2 = 5^2$

Hint: Does LHS = RHS?



Fluency

4, 5

4, 5



Example 1 Writing Pythagoras' theorem

Write down Pythagoras' theorem for this triangle.

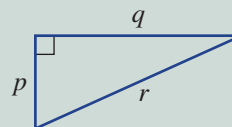

Solution

$$p^2 + q^2 = r^2$$

Explanation

r is the length of the hypotenuse and p and q are the lengths of the two shorter sides. Alternatively, $r^2 = p^2 + q^2$.

Now you try

Write down Pythagoras' theorem for this triangle.

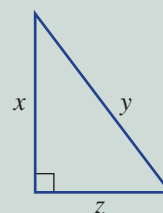

- 4 Write down Pythagoras' theorem for these triangles using the given pronumerals.

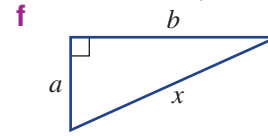
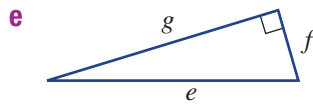
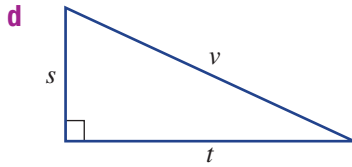
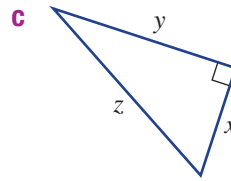
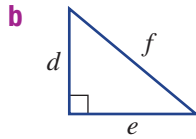
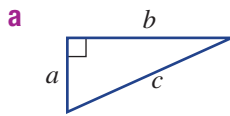

Hint: Replace the letters a , b and c in $a^2 + b^2 = c^2$ with the given letters.



Example 2 Substituting with Pythagoras' theorem

Substitute the numbers on this triangle into Pythagoras' theorem $a^2 + b^2 = c^2$.

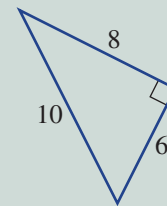

Solution

$$6^2 + 8^2 = 10^2$$

Explanation

10 is the length of the hypotenuse and 6 and 8 are the lengths of the two shorter sides.

Now you try

Substitute the numbers on this triangle into Pythagoras' theorem $a^2 + b^2 = c^2$.

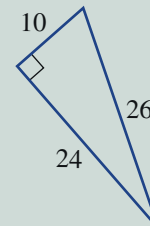

- 5 Substitute the numbers on these triangles into $a^2 + b^2 = c^2$.

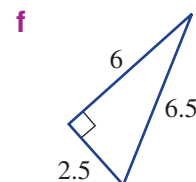
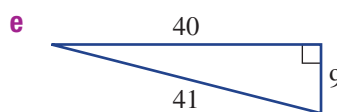
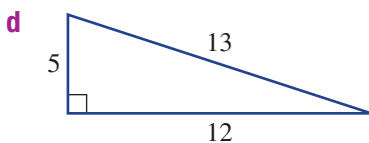
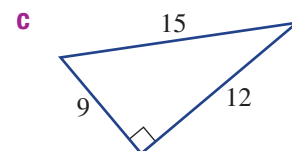
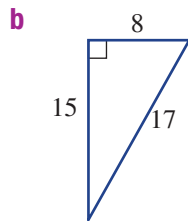
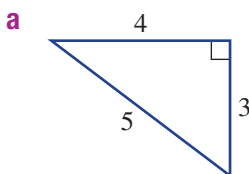

4A

Problem-solving and reasoning

6–8

7–10

6 Write down Pythagoras' theorem using the pronumerals given in these diagrams.

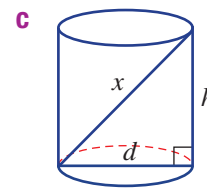
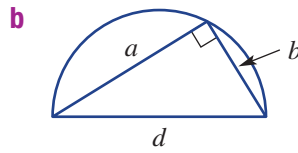
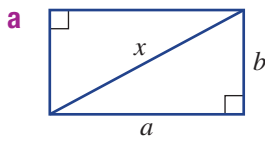

7 Complete this table and answer the questions below.

a	b	c	a^2	b^2	$a^2 + b^2$	c^2
3	4	5				
6	8	10				
8	15	17				

- a** Which two columns give equal results?
b What would be the value of c^2 if $a^2 + b^2 = c^2$ and:
i $a^2 = 4$ and $b^2 = 9$? **ii** $a^2 = 7$ and $b^2 = 13$?
c What would be the value of $a^2 + b^2$ if $a^2 + b^2 = c^2$ and:
i $c^2 = 25$? **ii** $c^2 = 110$?



8 A cable connects the top of a 30 m mast to a point on the ground. The cable is 40 m long and connects to a point 20 m from the base of the mast.

- a** Using $c = 40$, decide if $a^2 + b^2 = c^2$.
b Do you think the triangle formed by the mast and the cable is right angled? Give a reason.



9 If $a^2 + b^2 = c^2$, we know that the triangle must have a right angle. Which of these triangles must have a right angle?

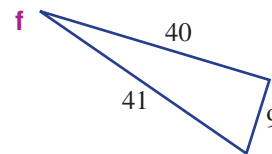
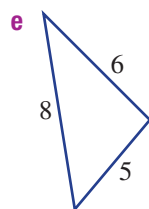
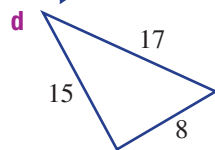
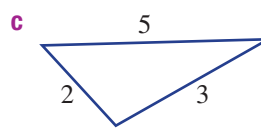
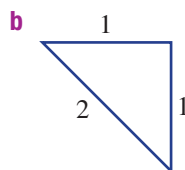
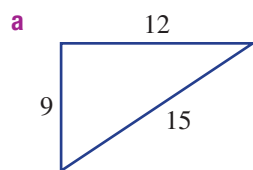

Hint: Substitute into $a^2 + b^2 = c^2$ to see if it's true.



10 (3, 4, 5) and (5, 12, 13) are Pythagorean triples, since $3^2 + 4^2 = 5^2$ and $5^2 + 12^2 = 13^2$. Find 10 more Pythagorean triples using whole numbers less than 100.

Hint: If (3, 4, 5) is a Pythagorean triple, then (6, 8, 10) is also a triple.



Pythagorean triples

—

11

11 Find the total number of Pythagorean triples with whole numbers of less than 100. Include any found from Question 10 above.

4B Finding the length of the hypotenuse

Learning intentions

- To be able to use Pythagoras' theorem to find the length of the hypotenuse given the other two sides
- To be able to find hypotenuse lengths both as rounded decimals or exact values including surds

Key vocabulary: hypotenuse, Pythagoras' theorem, right-angled, substitute, surds, square root

From our knowledge of formulas and equations we know that the value of one variable can be found if the values of all the other variables are known. With the help of Pythagoras' theorem, this means that an unknown side length of a right-angled triangle can be found if the other two sides are known. In this section we will find the length of the hypotenuse given the two shorter sides.



→ Lesson starter: Correct substitution

Here are three attempts at using Pythagoras' theorem for the given triangle.

$$\begin{array}{lll}
 c^2 = a^2 + b^2 & c^2 = a^2 + b^2 & c^2 = a^2 + b^2 \\
 = 3^2 + 4^2 & = 4^2 + 3^2 & = (3 + 4)^2 \\
 = 25 & = 25 & = 49 \\
 \therefore c = \sqrt{25} & \therefore c = \sqrt{25} & \therefore c = 7 \\
 = 5 & = 5 &
 \end{array}$$

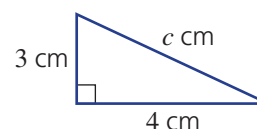

- Which set of working is incorrect? Give reasons.
- Why are the other two sets of working correct? Are they identical?

Key ideas

- To use Pythagoras' theorem to find the length of the hypotenuse:
 - Use the shorter lengths to substitute for a and b . This can be done in any order.
 - Find the value of $a^2 + b^2$.
 - Take the square root to find the value of c . Round if required.
- Lengths can be expressed with exact values using **surds**. $\sqrt{2}$, $\sqrt{28}$ and $2\sqrt{3}$ are examples of surds.
 - When expressed as a decimal, a surd is an infinite non-recurring decimal with no pattern; for example, $\sqrt{2} = 1.4142135623 \dots$

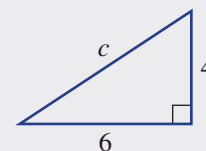

$$\begin{aligned}
 c^2 &= a^2 + b^2 \\
 &= 4^2 + 6^2 \\
 &= 16 + 36 \\
 &= 52 \\
 \therefore c &= \sqrt{52} \\
 &= 7.21 \text{ (to 2 d.p.)}
 \end{aligned}$$

Exercise 4B

Understanding

1–4

3, 4

1 State the length of the hypotenuse (c) in these right-angled triangles.

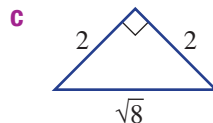
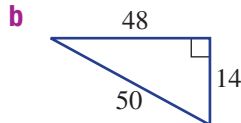
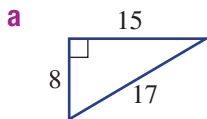

2 Write down Pythagoras' theorem using the given pronumerals and values for these right-angled triangles.

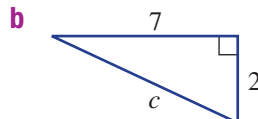
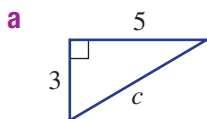

Hint: Write a statement such as $c^2 = 2^2 + 3^2$.



3 Identify the surds from the following list.

a $\sqrt{3}$

b 7

c 6.4

d $\sqrt{25}$

e 0.3

f $\sqrt{7}$



4 Find the value of c ($c > 0$) in the following using the square root. Round to one decimal place in parts **a** and **b** and answer as a surd in parts **c** and **d**.

a $c^2 = 45$

b $c^2 = 10 + 30$

c $c^2 = 22$

d $c^2 = 3^2 + 5^2$

Fluency

5(½), 6

5–7(½)



Example 3 Finding the length of the hypotenuse

Find the length of the hypotenuse in this right-angled triangle.

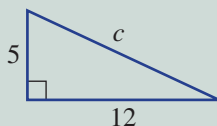

Solution

$$\begin{aligned} c^2 &= a^2 + b^2 \\ &= 5^2 + 12^2 \\ &= 169 \\ \therefore c &= \sqrt{169} \\ &= 13 \end{aligned}$$

Explanation

Write the rule and substitute the lengths of the two shorter sides. Any order is okay.

If $c^2 = 169$ then $c = \sqrt{169} = 13$.

Now you try

Find the length of the hypotenuse in this right-angled triangle.

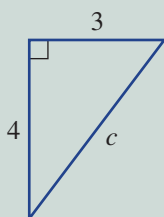

-  5 Find the length of the hypotenuse in each of the following right-angled triangles.

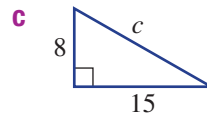
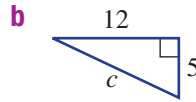
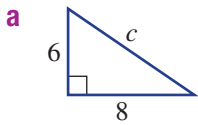

Hint: Substitute the two shorter sides for a and b in the equation $c^2 = a^2 + b^2$.

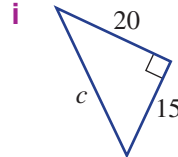
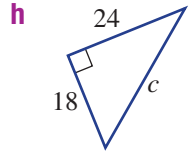
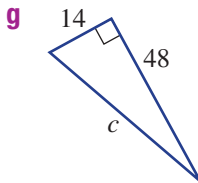
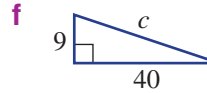
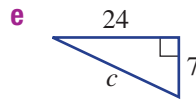
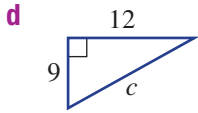

Example 4 Using rounding with Pythagoras' theorem

Find the length of the hypotenuse in this right-angled triangle, rounding to two decimal places.

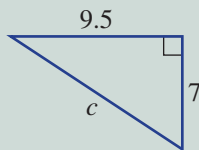

Solution

$$\begin{aligned} c^2 &= a^2 + b^2 \\ &= 7^2 + 9.5^2 \\ &= 139.25 \\ \therefore c &= \sqrt{139.25} \\ &= 11.80 \text{ (to 2 d.p.)} \end{aligned}$$

Explanation

The order for a and b does not matter since $7^2 + 9.5^2 = 9.5^2 + 7^2$.

$\sqrt{139.25} = 11.8004 \dots$ and the third decimal place is zero, so round down.

Now you try

Find the length of the hypotenuse in this right-angled triangle, rounding to two decimal places.

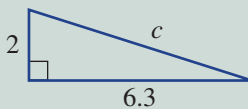

-  6 Find the length of the hypotenuse in each of these right-angled triangles, correct to two decimal places.

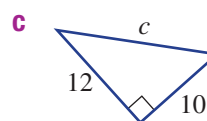
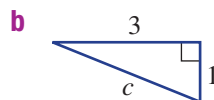
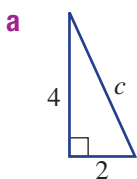

Hint: Use a calculator to find the value of c and round your answer to two decimal places.

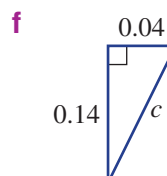
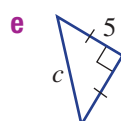
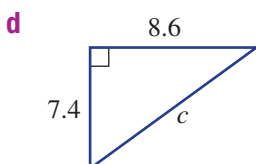

4B



Example 5 Finding the length of the hypotenuse using exact values

Find the length of the hypotenuse in this right-angled triangle, leaving your answer as an exact value.

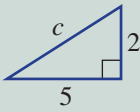

Solution

$$\begin{aligned}c^2 &= a^2 + b^2 \\ &= 5^2 + 2^2 \\ &= 29 \\ \therefore c &= \sqrt{29}\end{aligned}$$

Explanation

Apply Pythagoras' theorem to find the value of c .

Express the answer exactly using a surd.

Now you try

Find the length of the hypotenuse in this right-angled triangle, leaving your answer as an exact value.

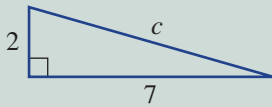

7 Find the length of the hypotenuse in these triangles, leaving your answer as an exact value.

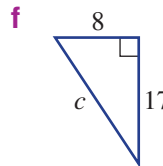
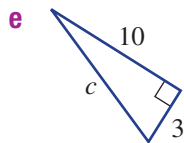
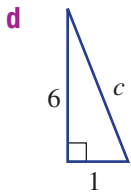
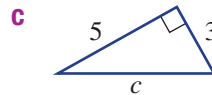
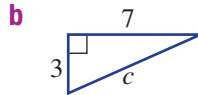
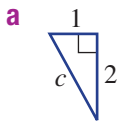

Hint: Leave your answer as a surd; e.g. $\sqrt{3}$ or $\sqrt{26}$.



Problem-solving and reasoning

8–10, 11(½)

10, 11(½), 12–14



8 Find the length of the diagonal steel brace required to support a wall of length 3.5 m and height 2.6 m. Give your answer correct to one decimal place.

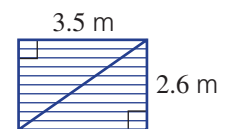

9 A miniature rocket blasts off at an angle of 45° and, after a few seconds, reaches a height of 350 m above the ground. At this point it has also covered a horizontal distance of 350 m. How far has the rocket travelled to the nearest metre?

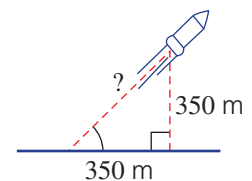

10 Find the length of the longest rod, as shown, that will fit inside a cylinder of height 2.1 m and with circular end surface of 1.2 m diameter. Give your answer correct to one decimal place.

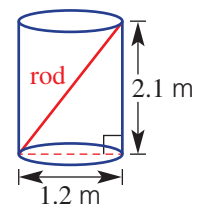

- 11** For each of these triangles, first calculate the length of the hypotenuse then find the perimeter, correct to two decimal places.

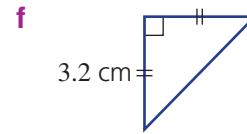
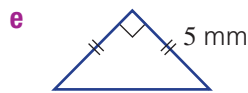
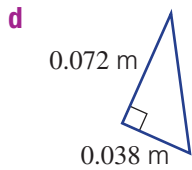
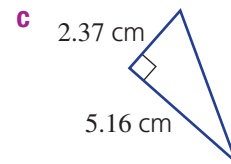
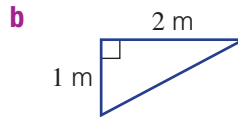
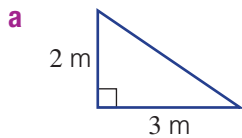

- 12** A helicopter hovers at a height of 150 m above the ground and is a horizontal distance of 200 m from a beacon on the ground. Find the direct distance of the helicopter from the beacon.

Hint: First draw a right-angled triangle.

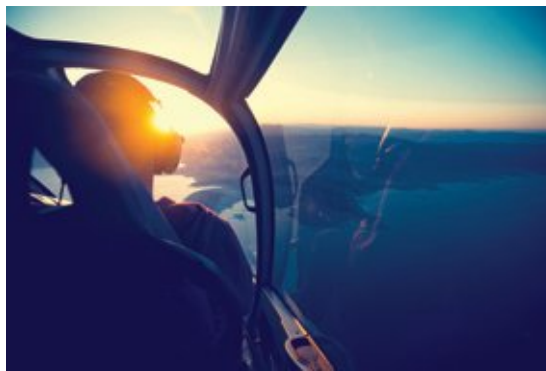

- 13** Find the perimeter of this triangle.

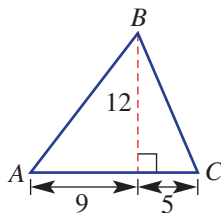

Hint: You will need to find AB and BC first by considering two different triangles.



- 14** One way to check whether a four-sided figure is a rectangle is to make sure that both its diagonals are the same length. What should the length of the diagonals be if a rectangle has side lengths 3 m and 5 m? Answer to two decimal places.



The dog kennel

—

15

- 15** A dog kennel has the dimensions shown in the diagram on the right. Give your answers to each of the following, correct to two decimal places.

- What is the width of the kennel?
- What is the total height, h m, of the kennel?
- If the sloping height of the roof was to be reduced from 55 cm to 50 cm, what difference would this make to the total height of the kennel? (Assume that the width is the same as in part **a**.)

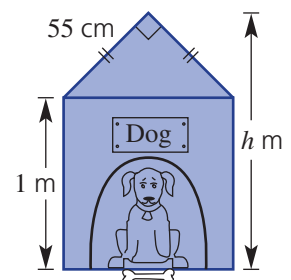

4C Finding the lengths of the shorter sides

Learning intentions

- To be able to set up Pythagoras' theorem where the unknown is a shorter side
- To be able to solve the resulting equation from Pythagoras' theorem to find the length of a shorter side

Key vocabulary: Pythagoras' theorem, hypotenuse, equation, square root, surd

We know that the sum $7 = 3 + 4$ can be written as a difference: $3 = 7 - 4$ or $4 = 7 - 3$. Likewise, if $c^2 = a^2 + b^2$ then $a^2 = c^2 - b^2$ or $b^2 = c^2 - a^2$.

Applying this idea to a right-angled triangle means that we can now find the length of one of the shorter sides if the other two sides are known.



Lesson starter: True or false

Below are some mathematical statements relating to a right-angled triangle with hypotenuse 10 and the two shorter sides 6 and b .

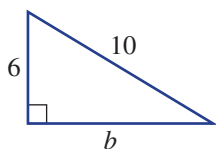

Some of these mathematical statements are true and some are false. Can you sort them into true and false groups?

$$6^2 + b^2 = 10^2$$

$$6 = \sqrt{10^2 - b^2}$$

$$10^2 - 6^2 = b^2$$

$$6^2 - 10^2 = b^2$$

$$10 = \sqrt{6^2 + b^2}$$

$$b = \sqrt{6^2 - 10^2}$$

$$10 = \sqrt{6^2 - b^2}$$

$$10^2 - b^2 = 6^2$$

Key ideas

- When finding the length of a shorter side:
 - Substitute known values into Pythagoras' theorem.
 - Solve this equation to find the unknown value.

For example:

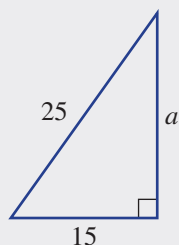

$$c^2 = a^2 + b^2$$

$$25^2 = a^2 + 15^2$$

$$625 = a^2 + 225$$

$$400 = a^2$$

$$\sqrt{400} = a$$

$$20 = a$$

$$\text{or } a = 20$$

Write out Pythagoras' theorem.

Substitute in the known values.

Subtract 225 from both sides.

To find a , take the square root of both sides.

Exercise 4C

Understanding

1-3

3

- Write the missing word or number.
 - To solve for a in $a^2 + 9 = 25$, the first step would be to _____ 9 from both sides.
 - To solve for b in $16 + b^2 = 49$, the first step would be to subtract _____ from both sides.
 - If $a^2 + 25 = 36$, then $a^2 = \underline{\quad}$.
- If $a^2 + 64 = 100$, decide if the following are true or false.
 - $a^2 = 100 - 64$
 - $64 = 100 + a^2$
 - $a = 6$
 - $a = 10$
- Find the value of b in these equations. (b is a positive number.)
 - $b^2 + 9 = 25$
 - $b^2 + 49 = 625$
 - $36 + b^2 = 100$

Hint: Solve for b^2 first.

Fluency

4-5(1/2)

4-5(1/2)



Example 6 Finding the length of a shorter side

Find the value of the pronumeral.

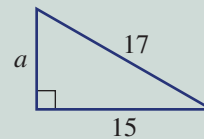

Solution

$$a^2 + 15^2 = 17^2$$

$$a^2 + 225 = 289$$

$$a^2 = 64$$

$$\therefore a = \sqrt{64}$$

$$a = 8$$

Explanation

Write the rule and substitute the known sides.

Square 15 and 17.

Subtract 225 from both sides.

Take the square root of both sides.

Now you try

Find the value of the pronumeral.

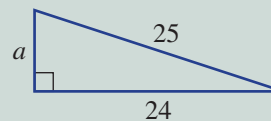

- Find the value of the pronumeral.

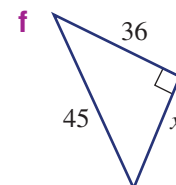
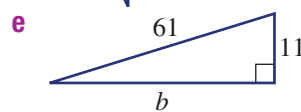
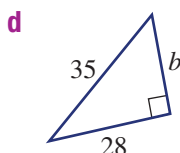
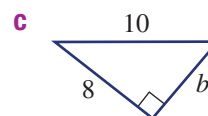
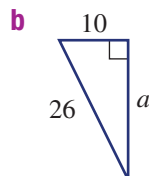
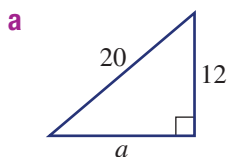
Hint: Substitute for a , b and c , then solve for the remaining pronumeral.

4C

Example 7 Using rounding to approximate the length of a shorter side

Find the value of x , rounding to two decimal places.

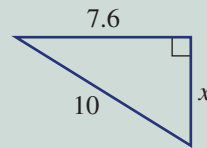
**Solution**

$$\begin{aligned}x^2 + 7.6^2 &= 10^2 \\x^2 + 57.76 &= 100 \\x^2 &= 42.24 \\\therefore x &= \sqrt{42.24} \\x &= 6.50 \text{ (to 2 d.p.)}\end{aligned}$$

Explanation

Write the rule and substitute $c = 10$ and $b = 7.6$

Subtract 57.76 from both sides.

Take the square root of both sides.

Round to two decimal places.

Now you try

Find the value of x , rounding to two decimal places.

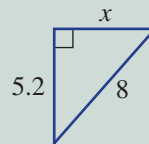

5 Find the value of the pronumeral. Express your answers correct to two decimal places.

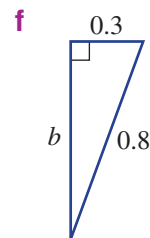
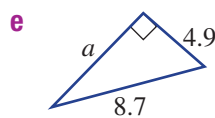
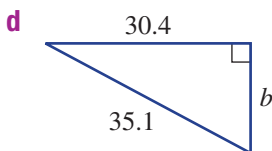
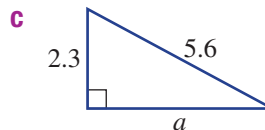
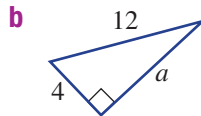
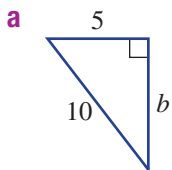

Hint: Use your calculator to get your answer, then round to two decimal places.

**Problem-solving and reasoning**

6–8

7–10



6 The base of a ladder leaning against a wall is 1.5 m from the base of the wall. The ladder is 5.5 m long. Find how high the top of the ladder is above the ground, correct to one decimal place.

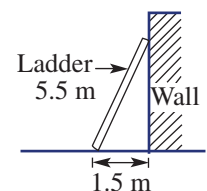

7 A 32 m communication tower is supported by 35 m cables stretching from the top of the tower to a position at ground level. Find the distance from the base of the tower to the point where the cable reaches the ground, correct to one decimal place.

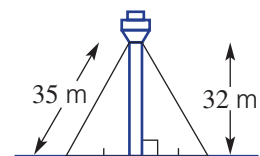

- 8** If a television has a screen size of 63 cm, it means that the diagonal length of the screen is 63 cm. If the vertical height of a 63 cm screen is 39 cm, find how wide the screen is to the nearest centimetre.

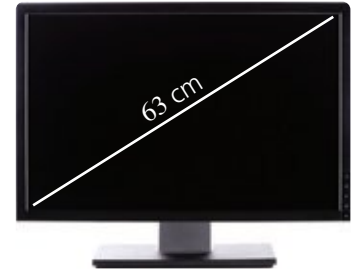

- 9** A 1.3 m vertical fence post is supported by a 2.27 m bar, as shown in the diagram on the right. Find the distance (d metres) from the base of the post to where the support enters the ground. Give your answer correct to two decimal places.

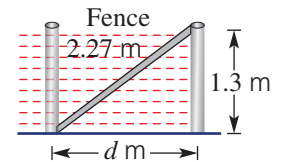

Example 8 Using Pythagoras' theorem and surds

Find the value of x , giving your answer as a surd.

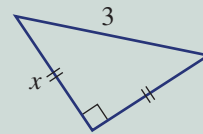

Solution

$$\begin{aligned} x^2 + x^2 &= 3^2 \\ 2x^2 &= 9 \\ x^2 &= \frac{9}{2} \\ \therefore x &= \sqrt{\frac{9}{2}} \text{ or } \frac{3}{\sqrt{2}} \end{aligned}$$

Explanation

Two sides are of length x .

Add like terms.

Divide both sides by 2.

Take the square root of both sides. To express as an exact answer, do not calculate the square root.

Now you try

Find the value of x , giving your answer as a surd.

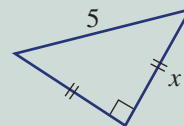

- 10** Find the value of x as an exact answer. Note that the triangles are isosceles.

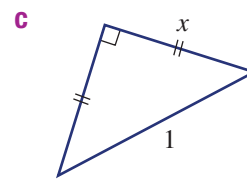
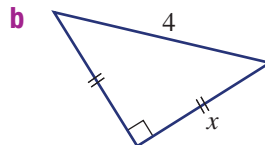
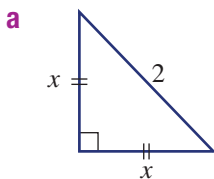

First find a missing length

11

- 11** Find the value of x . Give an exact answer each time.

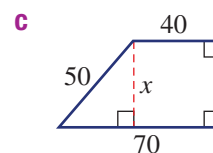
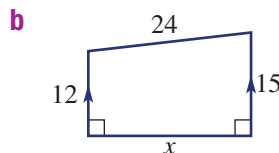
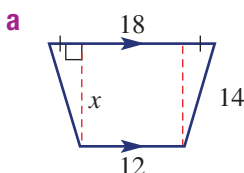

4D Applying Pythagoras' theorem

Learning intentions

- To be able to identify right-angled triangles in diagrams
- To be able to calculate unknown side lengths using given information and Pythagoras' theorem
- To be able to use Pythagoras' theorem to solve a problem

Key vocabulary: Pythagoras' theorem, right-angled

To apply Pythagoras' theorem to solve a real problem, it can help to first draw a right-angled triangle. This makes it easier to identify the unknown side. As long as two sides of the right-angled triangle are known, the length of the third side can be found.



The length of each cable on the Anzac Bridge, Sydney, can be calculated using Pythagoras' theorem.

→ Lesson starter: But where is the right-angled triangle?

A shed with two walls of length 3 m and 7 m has a sloping 10 m roof. We need to determine the distance between the two walls.

- Can you identify a right-angled triangle?
- What two side lengths on the right-angled triangle do you know?
- Show how Pythagoras' theorem can be used to find the unknown side.
- How would you put the answer in words?

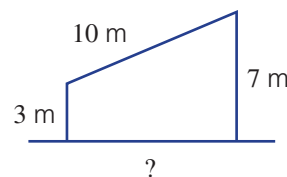

Key ideas

- When applying Pythagoras' theorem to real-world problems:
 - Identify and draw right-angled triangles that may help to solve the problem (shown in red on diagram).
 - Label the sides with their lengths or with a letter (pronumeral) if the length is unknown.
 - Use Pythagoras' theorem to solve for the unknown.
 - Solve the problem by making any further calculations and answering in words.
 - Check that the answer that you have appears to be reasonable in the given situation.

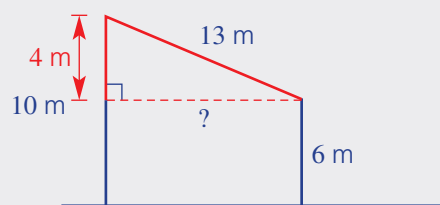

Exercise 4D

Understanding

1, 2

2

- 1 Two vertical posts are connected at the top by a wire as shown. Which of the following triangles could be used to help find the cable length?

A

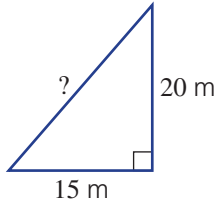

B

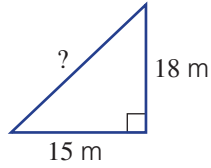

C

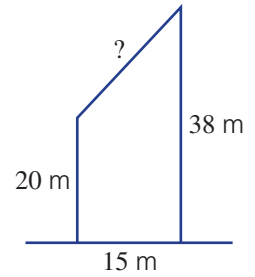
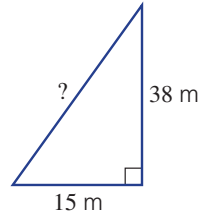

- 2 Match each problem (a, b or c) with both a diagram (A, B or C) and its solution (I, II, III).

- a Two trees stand 20 m apart. They are 32 m and 47 m tall. What is the distance between the tops of the two trees?

A

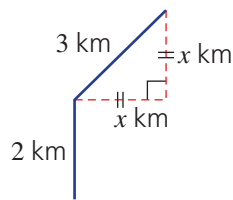

- I The kite is flying at a height of 30.59 m.

- b A kite is flying with a kite string of length 35 m. Its horizontal distance from its anchor point is 17 m. How high is the kite flying?

B

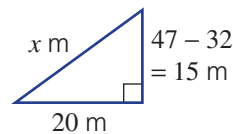

- II The man has walked a total of $2 + 2.12 = 4.12$ km north from his starting point.

- c A man walks due north for 2 km then north-east for 3 km. How far north is he from his starting point?

C

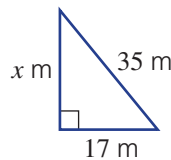

- III The distance between the top of the two trees is 25 m.

Fluency

3, 4, 6

3, 5, 6



Example 9 Identifying right-angled triangles in a diagram

An area of lawn is in the shape of a trapezium, as shown.

- a Draw a right-angled triangle to help find the unknown side length.
b Find the unknown side length correct to two decimal places.

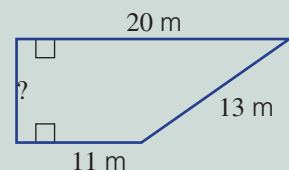

Solution

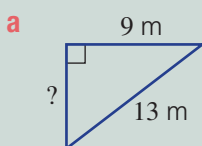

Explanation

The top side of the triangle is $20\text{ m} - 11\text{ m} = 9\text{ m}$.

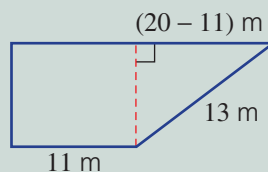

Continued on next page

4D

$$b \quad a^2 + b^2 = c^2$$

$$a^2 + 9^2 = 13^2$$

$$a^2 + 81 = 169$$

$$a^2 = 88$$

$$\therefore a = \sqrt{88}$$

$$= 9.38 \text{ (to 2 d.p.)}$$

The unknown length is 9.38 m.

Use Pythagoras' theorem with the hypotenuse as 13 m. Solve for a and round as required.

Now you try

A paved area is in the shape of a trapezium, as shown.

- a** Draw a right-angled triangle to help find the unknown side length.
b Find the unknown side length correct to two decimal places.

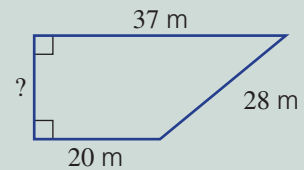

- 3** The side of a sculpture is in the shape of a trapezium, as shown.
a Draw a right-angled triangle to help find the unknown side length.
b Find the unknown length correct to two decimal places.

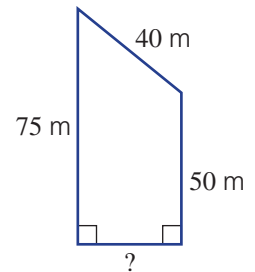

- 4** A scale drawing of the front of a dog kennel is shown. Find the unknown side length correct to two decimal places.

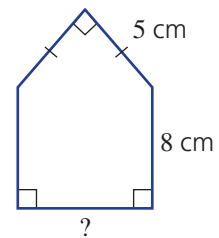

- 5** Find the direct distance between the points A and B in each of the following, correct to one decimal place.

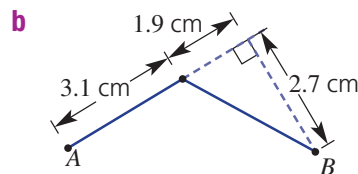
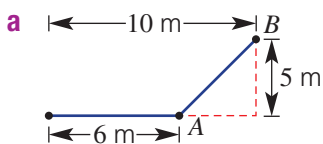

Hint: Draw in the right-angled triangle that will help to find the distance AB . The first one is shown for you.

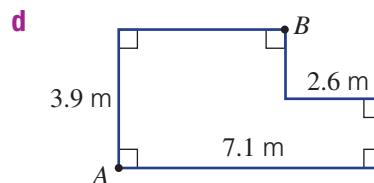
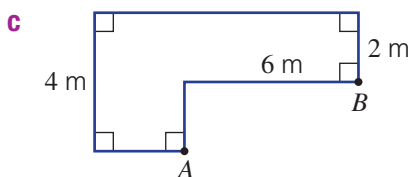



Example 10 Applying Pythagoras' theorem

Two skyscrapers are located 25 m apart and a cable links the tops of the two buildings. Find the length of the cable if the buildings are 50 m and 80 m in height. Give your answer correct to two decimal places.

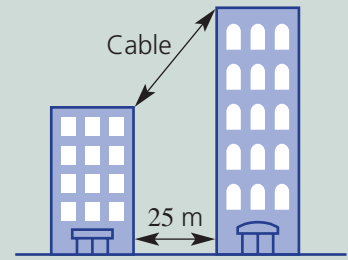

Solution

Let x m be the length of the cable.

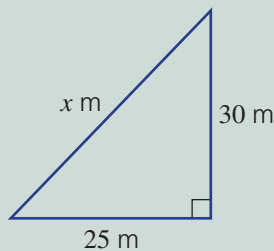

$$c^2 = a^2 + b^2$$

$$x^2 = 25^2 + 30^2$$

$$x^2 = 625 + 900$$

$$= 1525$$

$$\therefore x = \sqrt{1525}$$

$$= 39.05 \text{ (to 2 d.p.)}$$

\therefore The cable is 39.05 m long.

Explanation

Draw a right-angled triangle and label the measurements and pronumerals.

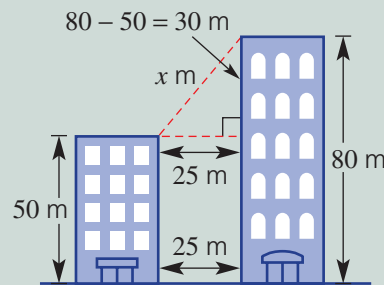

Set up an equation using Pythagoras' theorem and solve for x .

Answer the question in words.

Now you try

Two buildings are 20 m apart. A cable links the top of the two buildings. Find the length of the cable if the buildings are 40 m and 65 m in height. Give your answer correct to two decimal places.

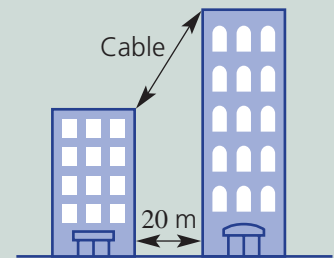

- 6 Two poles are located 2 m apart. A wire links the tops of the two poles. Find the length of the wire if the poles are 2.8 m and 5 m in height. Give your answer correct to one decimal place.

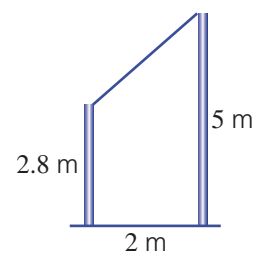

4D

Problem-solving and reasoning

7, 8

7, 9, 10

-  7 Two skyscrapers are located 25 m apart and a cable of length 62.3 m links the tops of the two buildings. If the taller building is 200 metres tall, what is the height of the shorter building? Give your answer correct to one decimal place.

Hint: First draw a right-angled triangle just like in Example 10. Then find the difference in their heights.



-  8 A garage is to be built with a skillion roof (a roof with a single slope). The measurements are given in the diagram. Calculate the pitch line length, to the nearest millimetre. Allow 500 mm for each of the eaves.

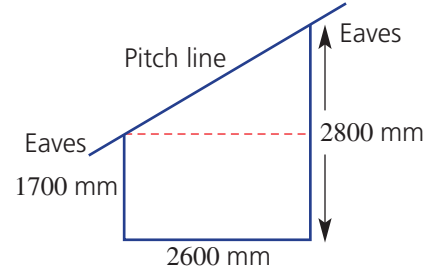

-  9 Two bushwalkers are standing on different mountain sides. According to their maps, one of them is at a height of 2120 m and the other is at a height of 1650 m. If the horizontal distance between them is 950 m, find the direct distance between the two bushwalkers. Give your answer correct to the nearest metre.

Hint: You will need to find the hypotenuse length of a right-angled triangle. Use a diagram like Example 10



-  10 A 100 m radio mast is supported by six cables in two sets of three cables. They are anchored to the ground at an equal distance from the mast. The top set of three cables is attached at a point 20 m below the top of the mast. Each cable in the lower set of three cables is 60 m long and is attached at a height of 30 m above the ground. If all the cables have to be replaced, find the total length of cable required. Give your answer correct to two decimal places.



Hint: First draw a diagram and add all the given information.



The suspension bridge

—

11

-  11 A suspension bridge is built with two vertical pylons and two straight beams of equal length. They extend from the top of the pylons to meet at a point, C , above the centre of the bridge, as shown in the diagram on the right.
- Calculate the vertical height of the point C above the tops of the pylons.
 - Calculate the distance between the pylons; that is, the length of the span of the bridge correct to one decimal place.

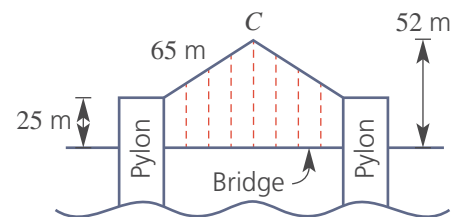

4E Trigonometric ratios

Learning intentions

- To know how to label the sides of a right-angled triangle as opposite, adjacent and hypotenuse
- To understand that the opposite and adjacent sides of a triangle are relative to the angle involved
- To know the trigonometric ratios for sine, cosine and tangent
- To understand that the trigonometric ratios are always the same if the angles in a right-angled triangle are the same
- To be able to write the correct trigonometric ratio for a right-angled triangle based on the given information

Key vocabulary: trigonometric ratio, opposite, adjacent, hypotenuse, sine, cosine, tangent, right-angled

The branch of mathematics called trigonometry deals with the relationship between the side lengths and angles in triangles. Trigonometry dates back to the ancient Egyptian and Babylonian civilisations where a basic form of trigonometry was used in the building of pyramids and in the study of astronomy. In the first century CE, Claudius Ptolemy advanced the study of trigonometry by writing 13 books called the *Almagest*. Ptolemy also developed tables of values linking the sides and angles of a triangle.



A basic form of trigonometry was used in the study of ancient astronomy.

Lesson starter: Constancy of sine, cosine and tangent

In geometry we would say that similar triangles have the same shape but are of different size. Here are three similar right-angled triangles. The angle θ (theta) is the same for all three triangles.

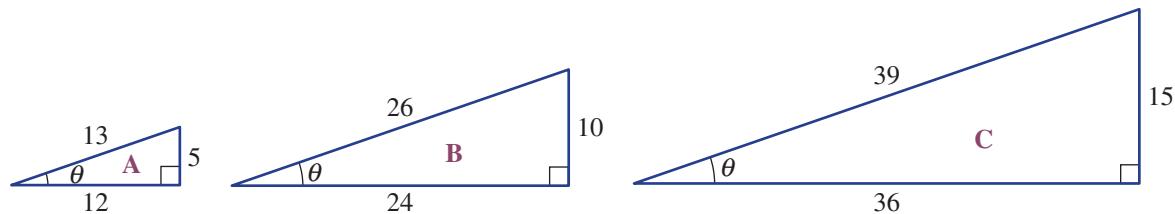

We will now calculate three special ratios for the angle θ in the above triangles: sine, cosine and tangent. We use the sides labelled Hypotenuse (H), Opposite (O) and Adjacent (A) as shown at right.

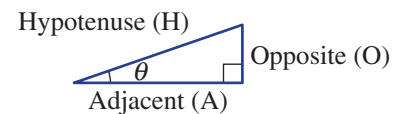

- Complete this table, simplifying all fractions.
- What do you notice about the value of:
 - $\sin \theta$ for all three triangles?
 - $\cos \theta$ for all three triangles?
 - $\tan \theta$ for all three triangles?
- Why are the three ratios ($\sin \theta$, $\cos \theta$ and $\tan \theta$) the same for all three triangles? Discuss.

Triangle	$\frac{O}{H}$ ($\sin \theta$)	$\frac{A}{H}$ ($\cos \theta$)	$\frac{O}{A}$ ($\tan \theta$)
A	$\frac{5}{13}$		
B		$\frac{24}{26} = \frac{12}{13}$	
C			$\frac{15}{36} = \frac{5}{12}$

4E

Key ideas

- If a right-angled triangle has one angle θ , then:
 - the longest side is called the hypotenuse (H)
 - the side opposite θ is called the **opposite** (O)
 - the remaining side is called the **adjacent** (A) (next to angle θ)

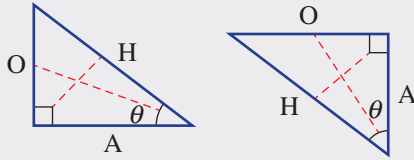

- For a right-angled triangle with a given angle θ , the three **trigonometric ratios: sine** (sin), **cosine** (cos) and **tangent** (tan) are given by:
 - sine of angle θ (or $\sin \theta$) = $\frac{\text{length of the opposite side}}{\text{length of the hypotenuse}}$
 - cosine of angle θ (or $\cos \theta$) = $\frac{\text{length of the adjacent side}}{\text{length of the hypotenuse}}$
 - tangent of angle θ (or $\tan \theta$) = $\frac{\text{length of the opposite side}}{\text{length of the adjacent side}}$
- For any right-angled triangle with the same angles, these ratios are always the same.
- The mnemonic SOHCAHTOA is useful when trying to remember the three ratios.

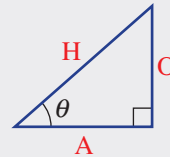

SOH CAH TOA

$$\sin \theta = \frac{\text{Opposite}}{\text{Hypotenuse}} \quad \cos \theta = \frac{\text{Adjacent}}{\text{Hypotenuse}} \quad \tan \theta = \frac{\text{Opposite}}{\text{Adjacent}}$$

Exercise 4E

Understanding

1, 2

2

- For this triangle:
 - What is the length of the hypotenuse?
 - What is the length of the side opposite θ ?
 - What is the length of the side adjacent to θ ?

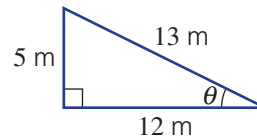

- Write the missing word in these sentences.
 - H stands for the word _____.
 - O stands for the word _____.
 - A stands for the word _____.
 - $\sin \theta = \frac{\text{_____}}{\text{Hypotenuse}}$.
 - $\cos \theta = \frac{\text{Adjacent}}{\text{_____}}$.
 - $\tan \theta = \frac{\text{Opposite}}{\text{_____}}$.

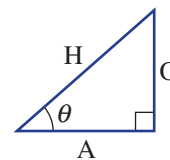

Fluency

3–5

3–4(1/2), 5, 6



Example 11 Labelling the sides of triangles

Copy this triangle and label the sides as opposite to θ (O), adjacent to θ (A) and hypotenuse (H).

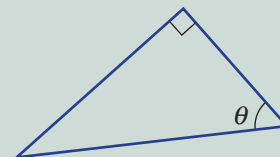

Solution

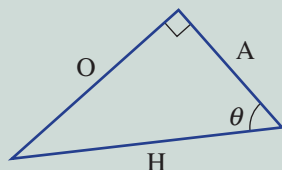

Explanation

Draw the triangle and label the side opposite the right angle as hypotenuse (H), the side opposite the angle θ as opposite (O) and the remaining side next to the angle θ as adjacent (A).

Now you try

Copy this triangle and label the sides as opposite to θ (O), adjacent to θ (A) and hypotenuse (H).

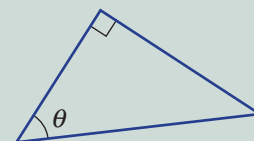

- 3 Copy each of these triangles and label the sides as opposite to θ (O), adjacent to θ (A) and hypotenuse (H).

a

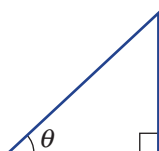

b

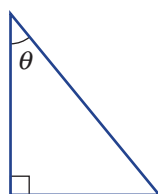

Hint: Alternatively, pencil the letters O, A and H onto this page.



c

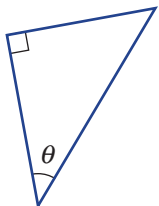

d

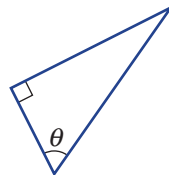

e

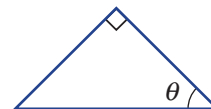

f

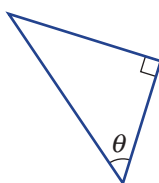

g

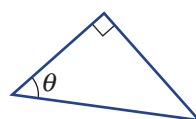

h

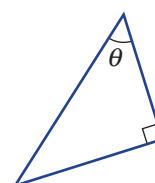

4E



Example 12 Writing trigonometric ratios

Write a trigonometric ratio (in fraction form) for each of the following triangles.

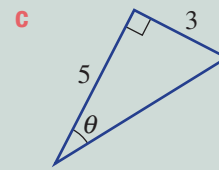
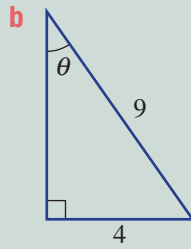
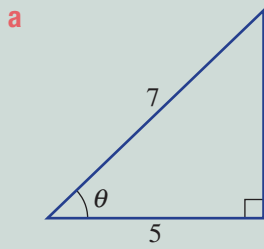

Solution

$$\begin{aligned} \mathbf{a} \quad \cos \theta &= \frac{A}{H} \\ \cos \theta &= \frac{5}{7} \end{aligned}$$

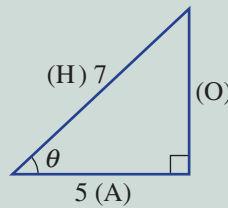

Explanation

Side length 7 is opposite the right angle so it is the hypotenuse (H). Side length 5 is adjacent to angle θ so it is the adjacent (A). Use $\cos \theta$ since we have A and H.

$$\begin{aligned} \mathbf{b} \quad \sin \theta &= \frac{O}{H} \\ \sin \theta &= \frac{4}{9} \end{aligned}$$

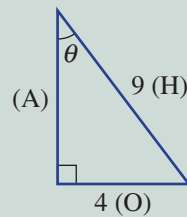

Side length 9 is opposite the right angle so it is the hypotenuse (H). Side length 4 is opposite angle θ so it is the opposite (O). Use $\sin \theta$ since we have O and H.

$$\begin{aligned} \mathbf{c} \quad \tan \theta &= \frac{O}{A} \\ \tan \theta &= \frac{3}{5} \end{aligned}$$

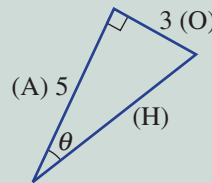

Side length 3 is opposite angle θ so it is the opposite (O). Side length 5 is the adjacent side to angle θ so it is the adjacent (A). Use $\tan \theta$ since we have O and A.

Now you try

Write a trigonometric ratio (in fraction form) for each of the following triangles.

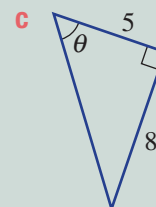
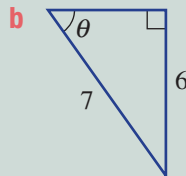
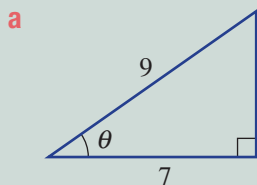

- 4 Write a trigonometric ratio (in fraction form) for each of the following triangles and simplify where possible.

a

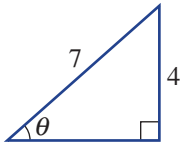

b

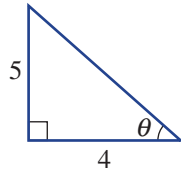

c

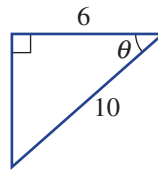

Hint: Use $\sin \theta$ if you have O and H, use $\cos \theta$ if you have A and H, and use $\tan \theta$ if you have O and A.



d

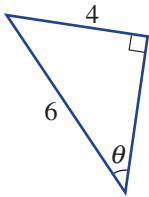

e

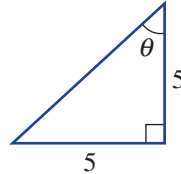

f

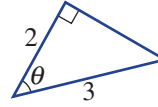

g

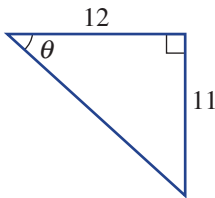

h

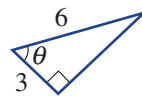

i

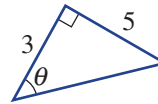

- 5 For each of these triangles, write a ratio (in simplified fraction form) for $\sin \theta$, $\cos \theta$ and $\tan \theta$.

a

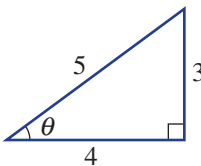

b

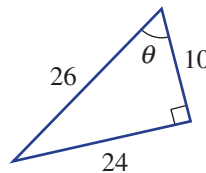

c

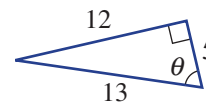

- 6 Here are two similar triangles, A and B.

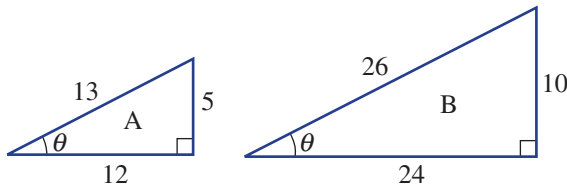

- a i Write the ratio $\sin \theta$ (as a fraction) for triangle A.
 ii Write the ratio $\sin \theta$ (as a fraction) for triangle B.
 iii What do you notice about your two answers from parts a i and a ii above?
- b i Write the ratio $\cos \theta$ (as a fraction) for triangle A.
 ii Write the ratio $\cos \theta$ (as a fraction) for triangle B.
 iii What do you notice about your two answers from parts b i and b ii above?
- c i Write the ratio $\tan \theta$ (as a fraction) for triangle A.
 ii Write the ratio $\tan \theta$ (as a fraction) for triangle B.
 iii What do you notice about your two answers from parts c i and c ii above?

Hint: Simplify your fractions from the larger triangle to help see the connection.



4E

Problem-solving and reasoning

7-9

8-11

- 7 The facade of a Roman temple has the given measurements. Write down the ratio for:

- a $\sin \theta$
 b $\cos \theta$
 c $\tan \theta$

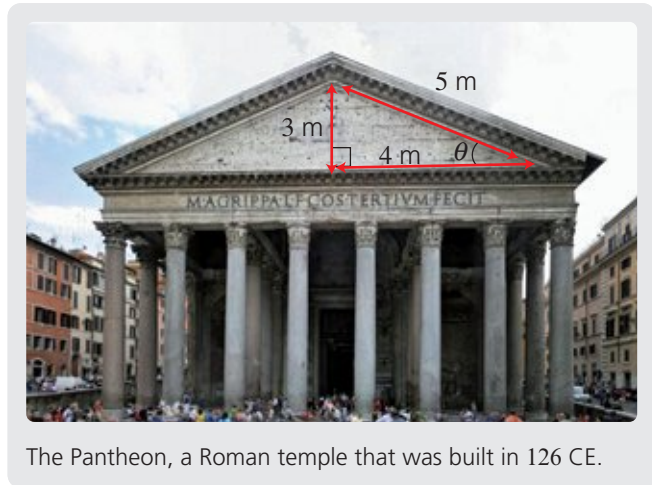

The Pantheon, a Roman temple that was built in 126 CE.

- 8 A vertical flag pole casts a shadow 20 m long. If the pole is 15 m high, find the ratio for $\tan \theta$.

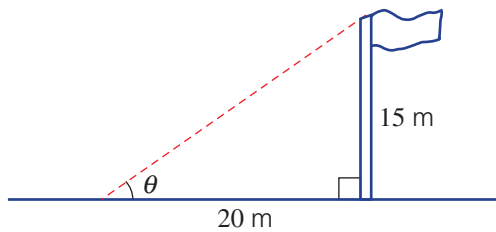

Hint: Decide which side is the opposite to θ and which side is adjacent to θ .



- 9 For the triangle shown, state the length of the side that corresponds to:

- a the hypotenuse
 b the side opposite angle θ
 c the side opposite angle α
 d the side adjacent to angle θ
 e the side adjacent to angle α .

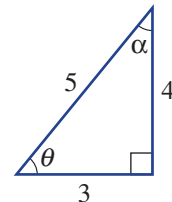

- 10 For the triangle shown on the right, write a ratio (in fraction form) for:

- a $\sin \theta$ b $\sin \alpha$ c $\cos \theta$
 d $\tan \alpha$ e $\cos \alpha$ f $\tan \theta$

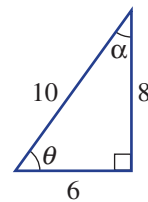

- 11 a Draw a right-angled triangle and mark one of the angles as θ . Mark in the length of the opposite side as 15 units and the length of the hypotenuse as 17 units.
 b Using Pythagoras' theorem, find the length of the adjacent side.
 c Determine the ratios for $\sin \theta$, $\cos \theta$ and $\tan \theta$.

Hint: Use $a^2 + b^2 = c^2$ for part b with $c = 17$ and $b = 15$.





The complementary connection

12, 13

12 This triangle has angles 90° , 60° and 30° and side lengths 1, 2 and $\sqrt{3}$.

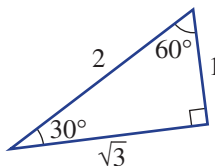

a Write a ratio for:

i $\sin 30^\circ$

ii $\cos 30^\circ$

iii $\tan 30^\circ$

iv $\sin 60^\circ$

v $\cos 60^\circ$

vi $\tan 60^\circ$

b What do you notice about the following pairs of ratios?

i $\cos 30^\circ$ and $\sin 60^\circ$

ii $\sin 30^\circ$ and $\cos 60^\circ$

13 a Measure all the side lengths of this triangle to the nearest millimetre.

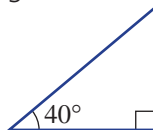

b Use your measurements from part **a** to find an approximate ratio for:

i $\cos 40^\circ$

ii $\sin 40^\circ$

iii $\tan 40^\circ$

iv $\sin 50^\circ$

v $\tan 50^\circ$

vi $\cos 50^\circ$

c Do you notice anything about the trigonometric ratios for 40° and 50° ?



Surveyors measure distances and angles and apply trigonometry to calculate other angles and distances.

4F Finding side lengths

Learning intentions

- To know how to use a calculator to evaluate \sin , \cos or \tan in degrees
- To be able to set up a trigonometric ratio to find a missing side length
- To know that at least one angle and one side length must be known to find another side length using trigonometry
- To be able to use a trigonometric ratio to find an unknown side length

Key vocabulary: trigonometric ratio, opposite, adjacent, hypotenuse, sine, cosine, tangent, right-angled, numerator

Since ancient times, mathematicians have attempted to tabulate the three trigonometric ratios for varying angles. Here are the ratios for some angles in a right-angled triangle, correct to three decimal places.

Angle (θ)	$\sin \theta$	$\cos \theta$	$\tan \theta$
0°	0	1	0
15°	0.259	0.966	0.268
30°	0.5	0.866	0.577
45°	0.707	0.707	1
60°	0.866	0.5	1.732
75°	0.966	0.259	3.732
90°	1	0	undefined



In modern times these values can be evaluated using calculators to a high degree of accuracy and can be used to help solve problems involving triangles with unknown side lengths.

Lesson starter: Calculator start up



All scientific or CAS calculators can produce accurate values of $\sin \theta$, $\cos \theta$ and $\tan \theta$.

- Ensure that your calculator is in degree mode.
- Find the value of the following, correct to three decimal places.
 - $\sin 50^\circ$
 - $\cos 81^\circ$
 - $\tan 36^\circ$
- Use trial and error to find (to the nearest degree) an angle, θ , which satisfies these conditions.
 - $\sin \theta = 0.454$
 - $\cos \theta = 0.588$
 - $\tan \theta = 9.514$

Key ideas

- If θ is in degrees, the ratios for $\sin \theta$, $\cos \theta$ and $\tan \theta$ can accurately be found using a calculator in degree mode.
- If the angles and one side length of a right-angled triangle are known, then the other side lengths can be found using the $\sin \theta$, $\cos \theta$ or $\tan \theta$ ratios.

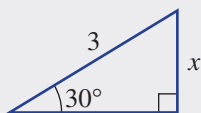

$$\begin{aligned}\sin 30^\circ &= \frac{x}{3} \\ x &= 3 \times \sin 30^\circ \\ &= 1.5\end{aligned}$$

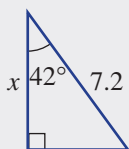

$$\begin{aligned}\cos 42^\circ &= \frac{x}{7.2} \\ x &= 7.2 \times \cos 42^\circ \\ &\approx 5.35\end{aligned}$$

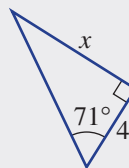

$$\begin{aligned}\tan 71^\circ &= \frac{x}{4} \\ x &= 4 \times \tan 71^\circ \\ &\approx 11.62\end{aligned}$$

Exercise 4F

Understanding

1–3

2, 3

- 1 For the marked angle θ , decide if x represents the length of the opposite (O), adjacent (A) or hypotenuse (H) side.

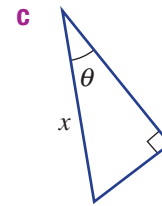
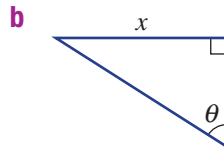
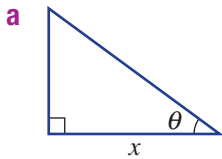

- 2 Decide whether you would use $\sin \theta = \frac{O}{H}$, $\cos \theta = \frac{A}{H}$ or $\tan \theta = \frac{O}{A}$ to help find the value of x in these triangles. Do not find the value of x ; just state which ratio would be used.

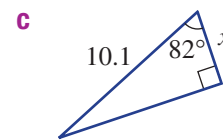
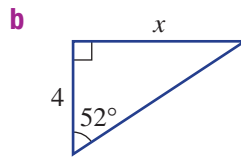
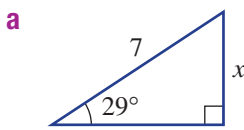

- 3 Which first step would be used to solve for x in the equation $\sin 70^\circ = \frac{x}{4}$

- A** Add 4 to both sides
C Subtract 4 from both sides

- B** Multiply both sides by 4
D Divide both side by 4

Fluency

4–6(1/2)

4–6(1/2)



Example 13 Using a calculator

Use a calculator to evaluate the following, correct to two decimal places.

a $\sin 50^\circ$

b $\cos 16^\circ$

c $\tan 77^\circ$

Solution

a $\sin 50^\circ = 0.77$ (to 2 d.p.)

Explanation

$\sin 50^\circ = 0.766044\dots$ the third decimal place is greater than 4, so round up.

b $\cos 16^\circ = 0.96$ (to 2 d.p.)

$\cos 16^\circ = 0.961261\dots$ the third decimal place is less than 5, so round down.

c $\tan 77^\circ = 4.33$ (to 2 d.p.)

$\tan 77^\circ = 4.331475\dots$ the third decimal place is less than 5, so round down.

Now you try

Use a calculator to evaluate the following, correct to two decimal places.

a $\sin 20^\circ$

b $\cos 38^\circ$

c $\tan 67^\circ$

4F



- 4 Use a calculator to evaluate the following correct to two decimal places.
- a** $\sin 20^\circ$ **b** $\cos 37^\circ$ **c** $\tan 64^\circ$ **d** $\sin 47^\circ$
e $\cos 84^\circ$ **f** $\tan 14.1^\circ$ **g** $\sin 27.4^\circ$ **h** $\cos 76.2^\circ$

Example 14 Solving for x in the numerator of a trigonometric ratio

Find the value of x in the equation $\cos 20^\circ = \frac{x}{3}$, correct to two decimal places.

Solution

$$\cos 20^\circ = \frac{x}{3}$$

$$\begin{aligned} x &= 3 \times \cos 20^\circ \\ &= 2.82 \text{ (to 2 d.p.)} \end{aligned}$$

Explanation

Multiply both sides of the equation by 3 and round as required.

Swap sides to put x on the left.

Now you try

Find the value of x in the equation $\cos 40^\circ = \frac{x}{5}$, correct to two decimal places.



- 5 Find the value of x correct to two decimal places.
- a** $\sin 50^\circ = \frac{x}{4}$ **b** $\tan 81^\circ = \frac{x}{3}$ **c** $\cos 33^\circ = \frac{x}{6}$
d $\cos 75^\circ = \frac{x}{3.5}$ **e** $\sin 24^\circ = \frac{x}{4.2}$ **f** $\tan 42^\circ = \frac{x}{10}$
g $\frac{x}{7.1} = \tan 18.4^\circ$ **h** $\frac{x}{5.3} = \sin 64.7^\circ$ **i** $\frac{x}{12.6} = \cos 52.9^\circ$

Hint: For part **a**, for example, multiply by 4 and use a calculator to evaluate $4 \times \sin 50^\circ$.



Example 15 Finding side lengths

For each triangle, find the value of x correct to two decimal places.

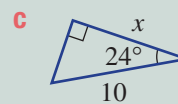
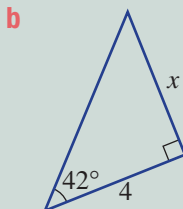
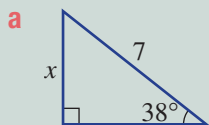

Solution

a $\sin 38^\circ = \frac{O}{H}$

$$\sin 38^\circ = \frac{x}{7}$$

$$\begin{aligned} x &= 7 \sin 38^\circ \\ &= 4.31 \text{ (to 2 d.p.)} \end{aligned}$$

Explanation

Since the opposite side (O) and the hypotenuse (H) are involved, the $\sin \theta$ ratio must be used. Use $\theta = 38^\circ$.

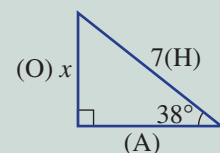

Multiply both sides by 7 and evaluate using a calculator.

b $\tan 42^\circ = \frac{O}{A}$

$\tan 42^\circ = \frac{x}{4}$

$x = 4 \tan 42^\circ$

$= 3.60$ (to 2 d.p.)

Since the opposite side (O) and the adjacent side (A) are involved, the $\tan \theta$ ratio must be used. Use $\theta = 42^\circ$.

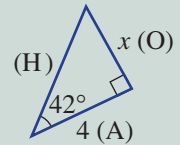

Multiply both sides by 4 and evaluate.

c $\cos 24^\circ = \frac{A}{H}$

$\cos 24^\circ = \frac{x}{10}$

$x = 10 \cos 24^\circ$

$= 9.14$ (to 2 d.p.)

Since the adjacent side (A) and the hypotenuse (H) are involved, the $\cos \theta$ ratio must be used.

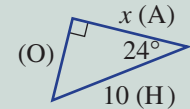

Multiply both sides by 10.

Now you try

For each triangle, find the value of x correct to two decimal places.

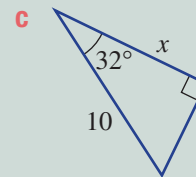
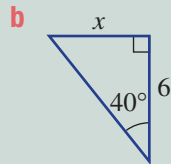
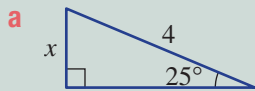

6 Find the value of x correct to two decimal places.

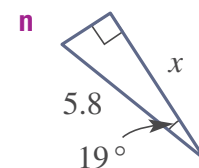
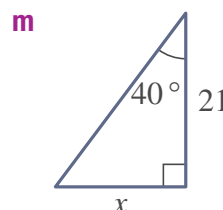
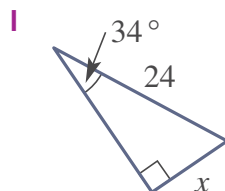
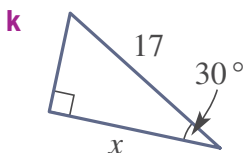
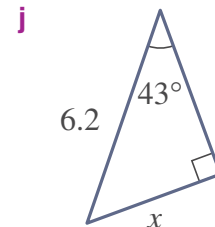
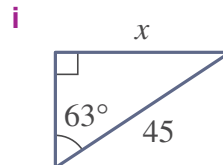
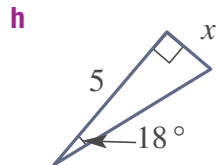
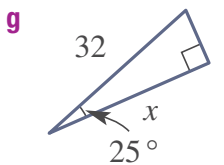
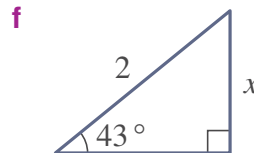
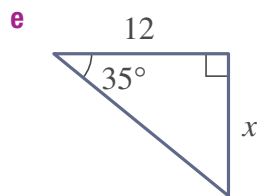
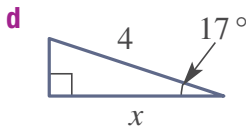
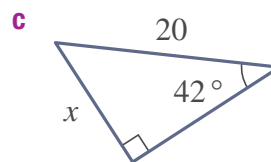
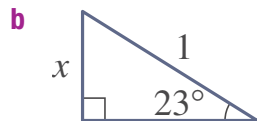
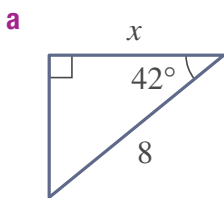

Hint: First decide which sides you have, including the unknown (O, A or H), then choose the correct ratio ($\sin \theta$, $\cos \theta$ or $\tan \theta$).



4F

Problem-solving and reasoning

7–9

8–11

- 7 A pole is supported by a 12 m cable that makes a 60° angle with the ground. How tall is the pole, correct to two decimal places?

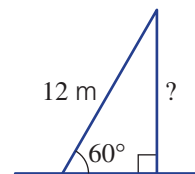

- 8 Amy walks 5.4 m up a ramp that is inclined at 12° to the horizontal. How high (correct to two decimal places) is she above her starting point?

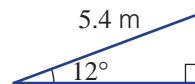

- 9 Kane wanted to measure the width of a river at a certain point. He placed two markers, A and B , 72 m apart along the bank. C is a point directly opposite marker B . Kane measured angle CAB to be 32° . Find the width of the river correct to two decimal places.

Hint: The 'width' is opposite (O) the 32° angle and the 72 m length is adjacent (A) to the 32° angle.

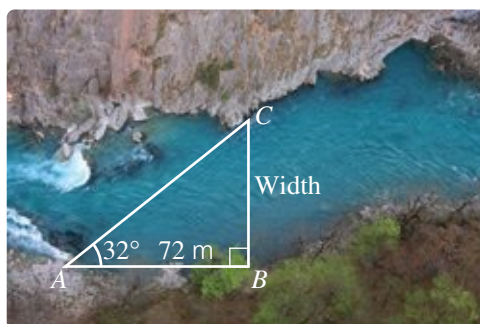

- 10 One end of a 12.2 m rope is tied to a boat. The other end is tied to an anchor, which is holding the boat steady in the water. If the anchor is making an angle of 34° with the vertical, how deep is the water? Give your answer correct to two decimal places.

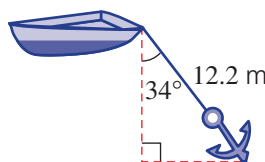

Hint: The depth length is adjacent (A) to the 34° angle.



- 11 For this right-angled triangle:
- Find the value of angle $\angle C$.
 - Calculate the value of x correct to three decimal places using the sine ratio.
 - Calculate the value of x correct to three decimal places but instead use the cosine ratio.

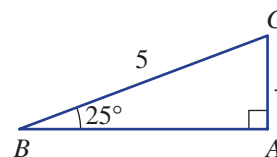

Combining multiple trigonometric calculations

—

12

- 12 Find the length AB in these diagrams. A combination of calculations is required. Round to two decimal places where necessary.

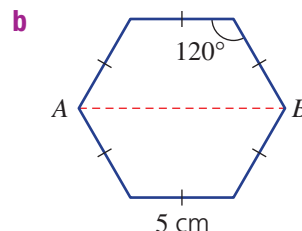
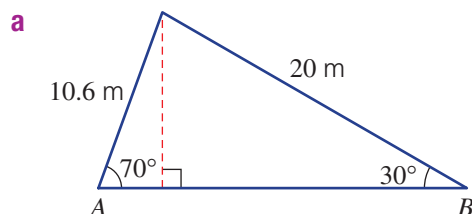

4A 1 Write down Pythagoras' theorem for these triangles using the pronumerals and numbers given.

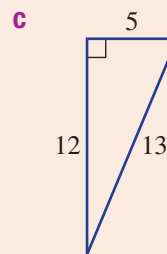
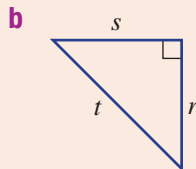
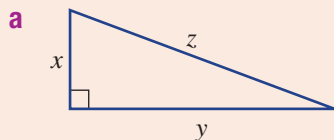

4B 2 Find the length of the hypotenuse in these right-angled triangles. Give exact answers for parts **a** and **b** and round to one decimal place in part **c**.

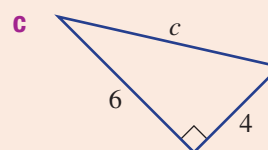
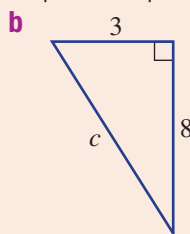
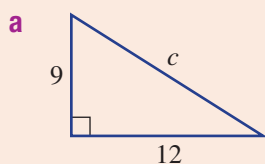

4C 3 Find the value of the pronumeral in these right-angled triangles. Round to two decimal places where necessary.

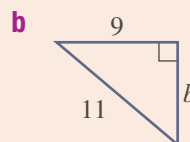
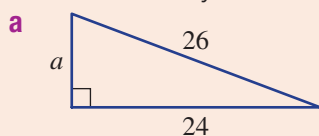

4C 4 A 3 m wooden plank is supporting an advertising billboard that is 2 m high. What is the distance of the plank from the base of the billboard? Round to one decimal place.

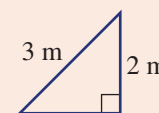

4D 5 A backyard deck is in the shape of a trapezium as shown. By drawing an appropriate right-angled triangle, find the width of the deck, w metres, correct to two decimal places.

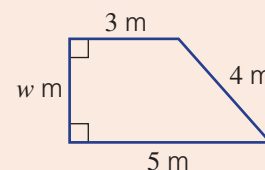

4D 6 Two telegraph poles 3.2 m and 5.4 m high are 2.4 m apart. A wire connects the top of the two poles. Find the length of the wire correct to one decimal place.

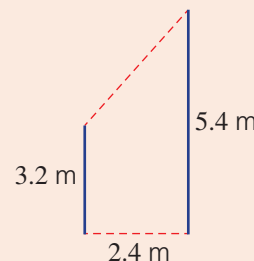

- 4E 7 Write a trigonometric ratio (in fraction form) for each of the following triangles.

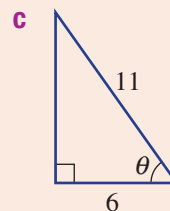
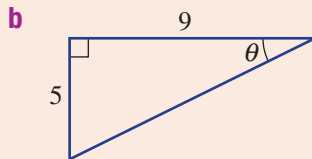
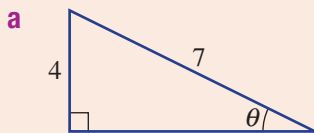

- 4F 8 Find the value of x , correct to two decimal places, in each of the following triangles.

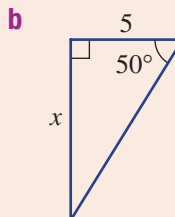
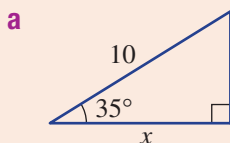

4F



- 9 A ladder leaning against a wall makes a 60° angle with the ground as shown. If the ladder is 3 m long, how far up the wall (x metres) does it reach? Round to one decimal place.

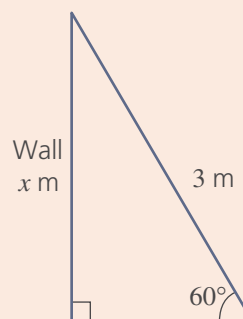

4G Solving for the denominator

Learning intentions

- To be able to use a trigonometric ratio to find an unknown in the denominator

Key vocabulary: trigonometric ratio, opposite, adjacent, hypotenuse, sine, cosine, tangent, right-angled, denominator

So far we have constructed trigonometric ratios using a pronumeral that has always appeared in the numerator. For example: $\sin 40^\circ = \frac{x}{5}$. This makes it easy to solve for x where both sides of the equation can be multiplied by 5. If, however, the pronumeral appears in the denominator, there are a number of algebraic steps that can be taken to find the solution.



→ Lesson starter: Solution steps

Three students attempt to solve $\sin 40^\circ = \frac{5}{x}$ for x .

Nick says $x = 5 \times \sin 40^\circ$

Sharee says $x = \frac{5}{\sin 40^\circ}$

Dori says $x = \frac{1}{5} \times \sin 40^\circ$

- Which student has the correct solution?
- Can you show the algebraic steps that support the correct answer?

Key ideas

- If the unknown value of a trigonometric ratio is in the denominator, you need to rearrange the equation to make the pronumeral the subject.

For example, for the triangle shown, multiplying both sides by x removes the fraction.

Dividing both sides by $\cos 30^\circ$ solves for x .

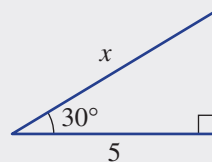

$$\cos 30^\circ = \frac{5}{x}$$

$$x \times \cos 30^\circ = 5$$

$$x = \frac{5}{\cos 30^\circ}$$

Exercise 4G

Understanding

1-3

3

- 1 Write the trigonometric ratio that would be used to find the value of x in these triangles.

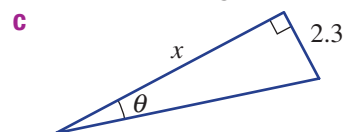
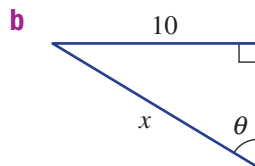
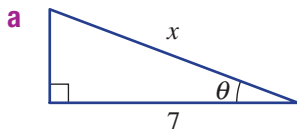

- 2 Which of the following equations is produced by multiplying both sides of $\sin 50^\circ = \frac{3}{x}$ by x ?

A $x = 3 \times \sin 50^\circ$

B $x = \frac{\sin 50^\circ}{3}$

C $x \times \sin 50^\circ = 3$

- 3 Complete the following solutions by filling in the boxes.

a $x \times \cos 25^\circ = 2$

$$x = \frac{2}{\boxed{}}$$

b $x \times \tan 65^\circ = 10$

$$x = \frac{10}{\boxed{}}$$

c $x \times \sin 72^\circ = 6$

$$x = \frac{\boxed{}}{\boxed{}}$$

Fluency

4-5(1/2)

4-5(1/2)



Example 16 Solving for x in the denominator

Solve for x in the equation $\cos 35^\circ = \frac{2}{x}$, correct to two decimal places.

Solution

$$\begin{aligned} \cos 35^\circ &= \frac{2}{x} \\ x \cos 35^\circ &= 2 \\ x &= \frac{2}{\cos 35^\circ} \\ &= 2.44 \text{ (to 2 d.p.)} \end{aligned}$$

Explanation

Multiply both sides of the equation by x .

Divide both sides of the equation by $\cos 35^\circ$.

Evaluate and round off to two decimal places.

Now you try

Solve for x in the equation $\tan 40^\circ = \frac{3}{x}$, correct to two decimal places.



- 4 Find the value of x correct to two decimal places.

a $\cos 43^\circ = \frac{3}{x}$

b $\sin 36^\circ = \frac{4}{x}$

c $\tan 9^\circ = \frac{6}{x}$

d $\tan 64^\circ = \frac{2}{x}$

e $\cos 67^\circ = \frac{5}{x}$

f $\sin 12^\circ = \frac{3}{x}$

g $\sin 38.3^\circ = \frac{5.9}{x}$

h $\frac{45}{x} = \tan 21.4^\circ$

i $\frac{18.7}{x} = \cos 32^\circ$

Hint: First multiply both sides by x .





Example 17 Finding side lengths

Find the value of x correct to two decimal places.

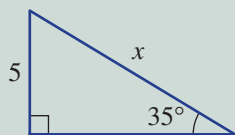

Solution

$$\sin 35^\circ = \frac{O}{H}$$

$$\sin 35^\circ = \frac{5}{x}$$

$$x \sin 35^\circ = 5$$

$$x = \frac{5}{\sin 35^\circ}$$

$$= 8.72 \text{ (to 2 d.p.)}$$

Explanation

Since the opposite side (O) is given and we require the hypotenuse (H), use $\sin \theta$.

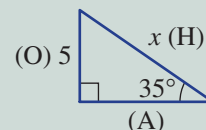

Multiply both sides of the equation by x then divide both sides of the equation by $\sin 35^\circ$.

Evaluate on a calculator and round off to two decimal places.

Now you try

Find the value of x correct to two decimal places.

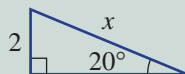

5 Find the value of x correct to two decimal places using the sine, cosine or tangent ratios.

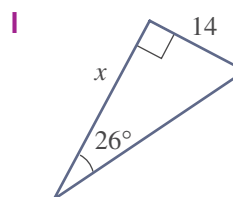
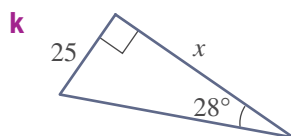
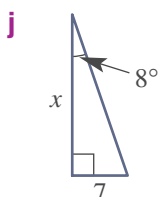
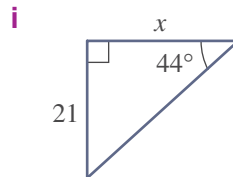
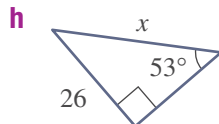
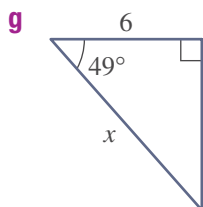
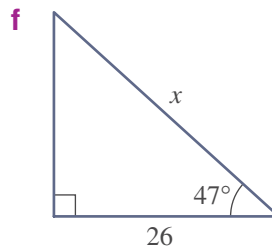
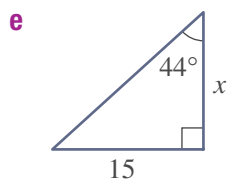
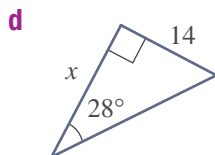
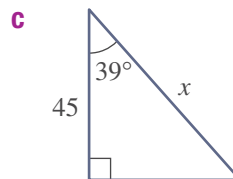
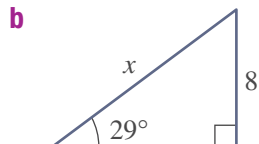
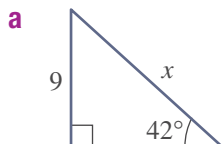

Hint: Are you going to use

$$\sin \theta = \frac{O}{H}, \cos \theta = \frac{A}{H} \text{ or}$$

$$\tan \theta = \frac{O}{A}?$$



4G

Problem-solving and reasoning

6–8

7–10



- 6 A kite is flying at a height of 27 m above the anchor point. If the string is inclined at 42° to the horizontal, find the length of the string correct to the nearest metre.

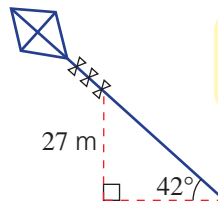

Hint: First decide if you are going to use $\sin \theta$ (SOH), $\cos \theta$ (CAH) or $\tan \theta$ (TOA).



- 7 A hang glider flying at a height of 800 m descends at an angle of 12° to the horizontal. How far (to the nearest metre) has it travelled in descending to the ground?

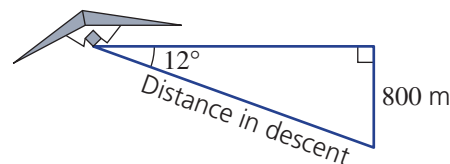

Example 18 Finding two side lengths on one triangle

Find the value of x and y correct to two decimal places.

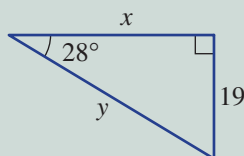

Solution

Explanation

$$\tan 28^\circ = \frac{O}{A}$$

$$\tan 28^\circ = \frac{19}{x}$$

$$x \tan 28^\circ = 19$$

$$x = \frac{19}{\tan 28^\circ}$$

$$= 35.73 \text{ (to 2 d.p.)}$$

$$\sin 28^\circ = \frac{19}{y}$$

$$y \sin 28^\circ = 19$$

$$y = \frac{19}{\sin 28^\circ}$$

$$= 40.47 \text{ (to 2 d.p.)}$$

Since the opposite side (O) is given and the adjacent (A) is required, use $\tan \theta$.

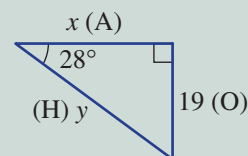

Multiply both sides of the equation by x .

Divide both sides of the equation by $\tan 28^\circ$ and round answer to two decimal places.

Use the opposite (19) as it is an exact length, so use $\sin \theta = \frac{O}{H}$.

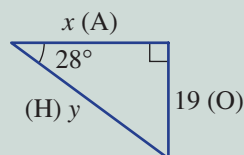

Alternatively, y can be found by Pythagoras' theorem.

Now you try

Find the value of x and y correct to two decimal places.

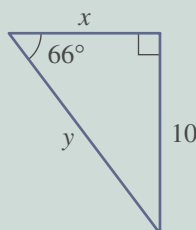

-  8 Find the value of each pronumeral correct to one decimal place.

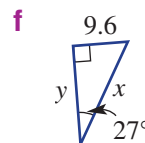
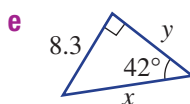
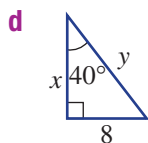
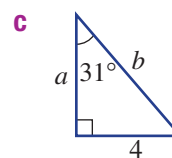
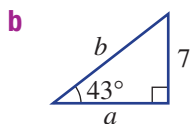
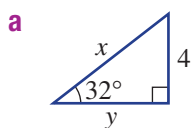

-  9 A mine shaft is dug at an angle of 15° to the horizontal. The horizontal length of the mine is 100 m. Answer the questions to the nearest metre.

a How far below ground level is the end of the shaft?

b How long is the mine shaft?

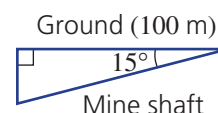

-  10 In calculating the value of x for this triangle, correct to two decimal places, two students come up with these answers.

A $x = \frac{5}{\sin 31^\circ} = \frac{5}{0.52} = 9.62$

B $x = \frac{5}{\sin 31^\circ} = 9.71$

a Which of the above two answers is more correct and why?

b What advice would you give to the student whose answer is not accurate?

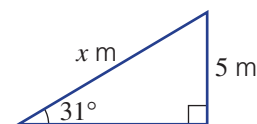

Trigonometry and perimeters

—

11

-  11 Find the perimeter of these triangles correct to one decimal place. You will first need to find the lengths of all the sides.

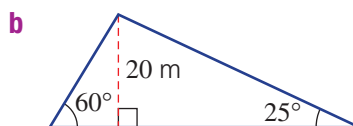
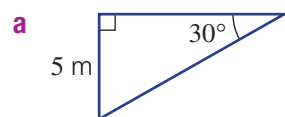

Using a calculator 4G: Trigonometry

 This activity can be found in the More Resources section of the Interactive Textbook in the form of a printable PDF.

4H Finding an angle

Learning intentions

- To know that inverse sine, inverse cosine and inverse tangent can be used to find angles in right-angled triangles
- To know that two side lengths must be known to find an unknown angle in a right-angled triangle
- To be able to evaluate the inverse trigonometric ratios on a calculator
- To be able to use the inverse trigonometric functions to find an unknown angle

Key vocabulary: trigonometric ratio, inverse sine, inverse cosine, inverse tangent, opposite, adjacent, hypotenuse, sine, cosine, tangent

Given two sides of a right-angled triangle, we can work out the unknown angles.

By using one of the three trigonometric ratios, we can use inverse trigonometric functions to find a value of θ .

For example, if $\cos \theta = 0.5$, then
 $\theta = \cos^{-1}(0.5) = 60^\circ$

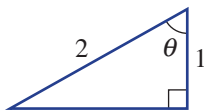

Surveyors use trigonometry to measure the height and angles of land.

Lesson starter: Trial and error can be slow

We know that for this triangle, $\sin \theta = \frac{1}{3}$

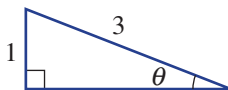

- Guess the angle θ .
- For your guess, use a calculator to see if $\sin \theta = \frac{1}{3}$ ($= 0.333\dots$) for your chosen value of θ .
- Update your guess and use your calculator to check once again.
- Repeat this trial-and-error process until you think you have the angle θ correct to three decimal places.
- Now evaluate $\sin^{-1}\left(\frac{1}{3}\right)$ and check your guess.

Key ideas

- **Inverse sine** (\sin^{-1}), **inverse cosine** (\cos^{-1}) and **inverse tangent** (\tan^{-1}) can be used to find angles in right-angled triangles.

- $\sin \theta = \frac{3}{5}$ means $\theta = \sin^{-1}\left(\frac{3}{5}\right)$
- $\cos \theta = \frac{4}{5}$ means $\theta = \cos^{-1}\left(\frac{4}{5}\right)$
- $\tan \theta = \frac{3}{4}$ means $\theta = \tan^{-1}\left(\frac{3}{4}\right)$

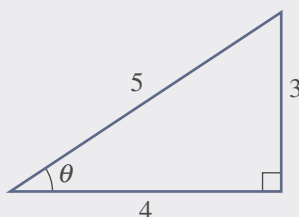

- Note that $\sin^{-1} x$ does *not* mean $\frac{1}{\sin x}$.
- The \sin^{-1} , \cos^{-1} , and \tan^{-1} functions can be found on most calculators.

Exercise 4H

Understanding

1–3

3

- 1 Write the trigonometric ratio for these triangles, e.g. $\sin \theta = \frac{8}{9}$ in part **a**.

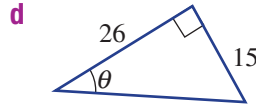
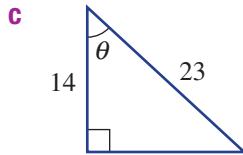
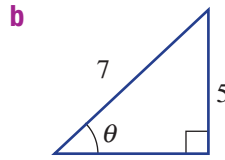
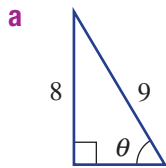

Hint: Choose $\sin \theta$ if using O and H, $\cos \theta$ if using A and H, and $\tan \theta$ if using O and A.



- 2 Use a calculator to evaluate the following, rounding to two decimal places.
- a** $\sin^{-1}(0.2)$ **b** $\cos^{-1}(0.43)$ **c** $\tan^{-1}(2.5)$

- 3 Complete the following by filling in the boxes.

a If $\cos \theta = \frac{1}{2}$

then $\theta = \cos^{-1}(\square)$

b If $\sin \theta = 0.6$

then $\theta = \sin^{-1}(\square)$

c If $\tan \theta = \frac{5}{4}$

then $\theta = \square$

Fluency

4–6(1/2)

4–6(1/2)

Example 19 Using inverse trigonometric ratios

Find the value of θ to the nearest degree if $\sin \theta = 0.3907$.

Solution

$$\sin \theta = 0.3907$$

$$\theta = \sin^{-1}(0.3907)$$

$$= 23^\circ \text{ (to nearest degree)}$$

Explanation

Use the \sin^{-1} key on your calculator

Round off to the nearest whole number.

Now you try

Find the value of θ to the nearest degree if $\sin \theta = 0.464$.

- 4 Find the value of θ to the nearest degree.
- a** $\sin \theta = 0.5$ **b** $\cos \theta = 0.5$ **c** $\tan \theta = 1$
- d** $\cos \theta = 0.8660$ **e** $\sin \theta = 0.7071$ **f** $\tan \theta = 0.5774$
- g** $\sin \theta = 1$ **h** $\tan \theta = 1.192$ **i** $\cos \theta = 0$
- j** $\cos \theta = 0.5736$ **k** $\cos \theta = 1$ **l** $\sin \theta = 0.9397$

Hint: Use the \sin^{-1} , \cos^{-1} or \tan^{-1} functions.



4H

Example 20 Using inverse trigonometric ratios with fractions



Find the value of θ correct to two decimal places if $\tan \theta = \frac{1}{2}$.

Solution

$$\tan \theta = \frac{1}{2}$$

$$\begin{aligned}\theta &= \tan^{-1}\left(\frac{1}{2}\right) \\ &= 26.57^\circ \text{ (to 2 d.p.)}\end{aligned}$$

Explanation

Use the \tan^{-1} key on your calculator and round the answer to two decimal places.

Now you try

Find the value of θ correct to two decimal places if $\cos \theta = \frac{2}{3}$.



5 Find the angle θ correct to two decimal places.

a $\sin \theta = \frac{4}{7}$

b $\sin \theta = \frac{1}{3}$

c $\sin \theta = \frac{9}{10}$

d $\cos \theta = \frac{1}{4}$

e $\cos \theta = \frac{4}{5}$

f $\cos \theta = \frac{7}{9}$

g $\tan \theta = \frac{3}{5}$

h $\tan \theta = \frac{8}{5}$

i $\tan \theta = 12$

Hint: For part **a**, type $\sin^{-1}\left(\frac{4}{7}\right)$ on your calculator.



Example 21 Finding an angle

Find the value of θ to the nearest degree.

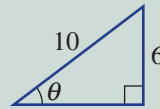
**Solution**

$$\begin{aligned}\sin \theta &= \frac{O}{H} \\ &= \frac{6}{10}\end{aligned}$$

$$\begin{aligned}\theta &= \sin^{-1}\left(\frac{6}{10}\right) \\ &= 37^\circ \text{ (to nearest degree)}\end{aligned}$$

Explanation

Since the opposite side (O) and the hypotenuse (H) are given, use $\sin \theta$.

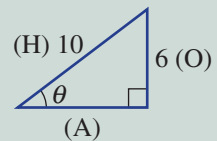

Use the \sin^{-1} key on your calculator and round as required.

Now you try

Find the value of θ to the nearest degree.

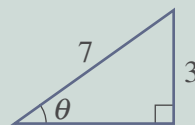



6 Find the value of θ to the nearest degree.

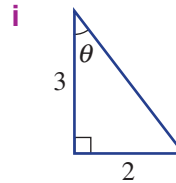
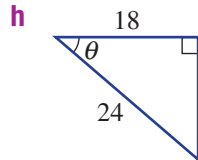
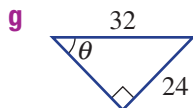
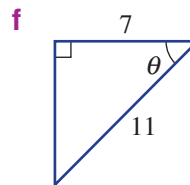
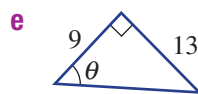
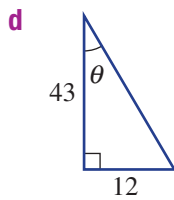
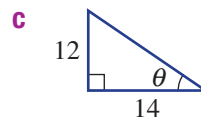
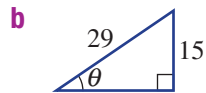
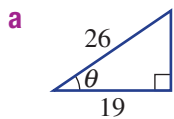

Hint: First set up an equation (like those in Question 5), then use a calculator to find θ .



Problem-solving and reasoning

7-9

9-12



7 A road rises at a grade of 3 in 10. Find the angle (to the nearest degree) the road makes with the horizontal.

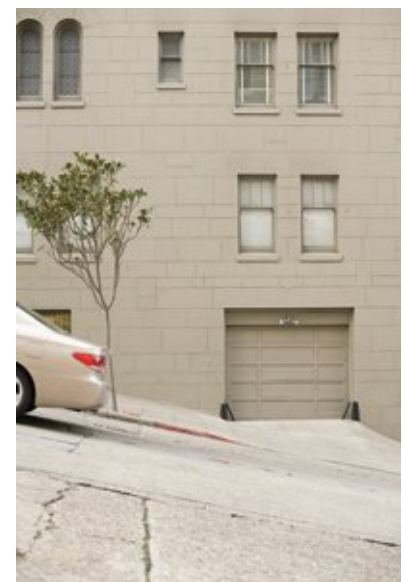
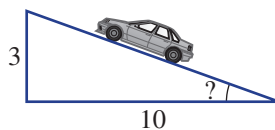

8 When a 2.8 m long seesaw is at its maximum height, it is 1.1 m off the ground. What angle (correct to two decimal places) does the seesaw make with the ground?

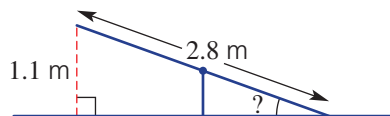

Hint: The 1.1 m length is opposite the angle and the 2.8 m length forms the hypotenuse.



9 Write the missing number.

a If $\sin 30^\circ = \frac{1}{2}$ then $30^\circ = \sin^{-1}(\underline{\hspace{2cm}})$.

b If $\cos 50^\circ = 0.64$ then $\underline{\hspace{2cm}} = \cos^{-1}(0.64)$.

c If $\tan 45^\circ = 1$ then $\underline{\hspace{2cm}} = \tan^{-1}(\underline{\hspace{2cm}})$.

d If $\sin 45^\circ = 0.707$ then $45^\circ = \sin^{-1}(\underline{\hspace{2cm}})$.

4H



- 10 Adam holds one end of a plank of wood 1.8 m above the ground. The other end of the plank rests on the ground. The plank of wood is 4.2 m long. Find the angle that the plank makes with the ground (θ), correct to one decimal place.

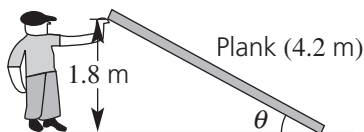

- 11 A ladder has a length of 5.8 m. The ladder is resting against the top of a platform that is 2.6 m high. Find the angle the ladder makes with the ground, correct to one decimal place.

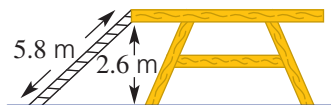

- 12 For what value of θ is $\sin \theta = \cos \theta$? Choose a value of θ between 0° and 90° .



Viewing angle

13



- 13 Joe has trouble with his eyesight but every Sunday he goes to view his favourite painting at the gallery. His eye level is at the same level as the base of the painting and the painting is 1 metre tall.

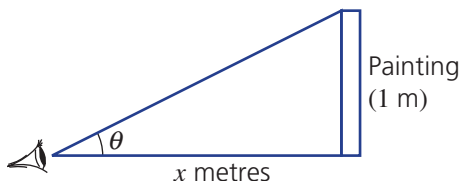

Answer the following to the nearest degree for angles and to two decimal places for lengths.

- If $x = 3$, find the viewing angle θ .
- If $x = 2$, find the viewing angle θ .
- If Joe can stand no closer than 1 metre to the painting, what is Joe's largest viewing angle?
- When the viewing angle is 10° , Joe has trouble seeing the painting. How far is he from the painting at this viewing angle?
- What would be the largest viewing angle if Joe could go as close as he would like to the painting?



4I Applying trigonometry

Learning intentions

- To be able to solve word problems using trigonometry by drawing a diagram and identifying appropriate right-angled triangles
- To know that angles of elevation and depression are measured from the horizontal
- To know that the angle of elevation and angle of depression between the same two points is equal
- To be able to work with angles of elevation and depression in diagrams and word problems

Key vocabulary: angle of elevation, angle of depression and horizontal

In many practical maths problems, trigonometry can be used to find unknown lengths and angles. Two special angles are called the angle of elevation and the angle of depression. These angles are measured from the horizontal.



→ Lesson starter: The cat and the bird

For the situation below, draw a detailed diagram showing these features:

- an angle of elevation (rising from the horizontal)
- an angle of depression (falling from the horizontal)
- any given lengths
- a right-angled triangle that will help to solve the problem

A cat and a bird eye each other from their respective positions. The bird is 20 m up a tree and the cat is on the ground 30 m from the base of the tree. Find the angle that their line of sight makes with the horizontal.

Compare your diagram with others in your class. Is there more than one triangle that could be drawn and used to solve the problem?

Key ideas

- To solve application problems involving trigonometry:
 - Draw a diagram and label the key information.
 - Identify and draw the appropriate right angled triangles separately.
 - Solve using trigonometry to find the missing measurements.
 - Express your answer in words.

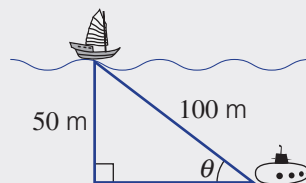

- **Angles of elevation** and **depression** are always measured from the **horizontal**.

- angle of elevation is looking up at an object

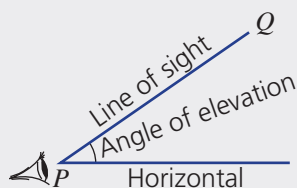

- angle of depression is looking down at an object

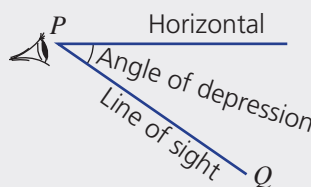

- Between the same two points the angle of elevation is equal to the angle of depression.

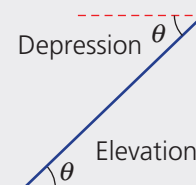

Exercise 4I

Understanding

1–4

3, 4

- 1 Draw this diagram and complete these tasks.

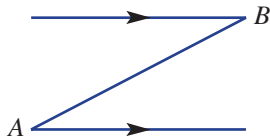

- a Mark in the following.
- The angle of elevation (θ) of B from A
 - The angle of depression (α) of A from B
- b Is $\theta = \alpha$ in your diagram? Why?

- 2 Choose the diagram (A, B or C) that matches this situation. A boy views a kite at an angle of elevation of 28° .

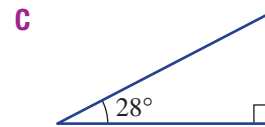
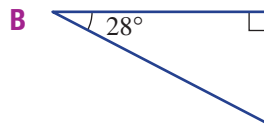
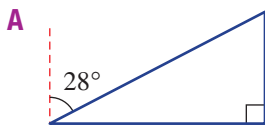

- 3 For this diagram:

- What is the angle of elevation of B from A ?
- What is the angle of depression of A from B ?

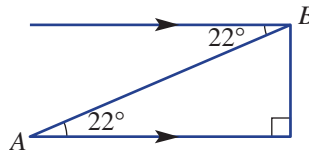

Hint: Why do you think the two angles are equal in this diagram?



- 4 Find the values of the pronumerals in this diagram.

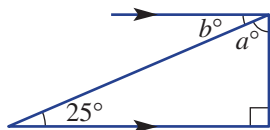

Fluency

5, 7, 9, 10

5, 6, 8–10



Example 22 Using angles of elevation

The angle of elevation of the top of a tower from a point on the ground 30 m away from the base of the tower is 28° . Find the height of the tower to the nearest metre.

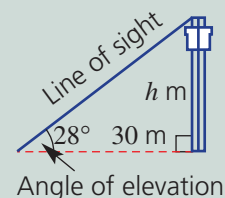

Solution

Let the height of the tower be h m.

$$\tan 28^\circ = \frac{O}{A}$$

$$= \frac{h}{30}$$

$$h = 30 \tan 28^\circ$$

$$= 16 \text{ (to nearest metre)}$$

The height is 16 m.

Explanation

Since the opposite side (O) is required and the adjacent (A) is given, use $\tan \theta$.

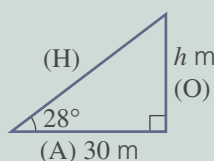

Multiply both sides by 30 and evaluate, rounding to the nearest metre.

Write the answer in words.

Now you try

The angle of elevation of the top of a tower from a point on the ground 40 m from the base of the tower is 36° . Find the height of the tower to the nearest metre.

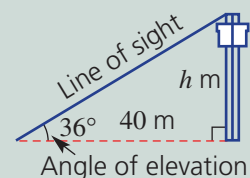

- 5 The angle of elevation of the top of a castle wall from a point on the ground 25 m from the base of the castle wall is 32° . Find the height of the castle wall to the nearest metre.

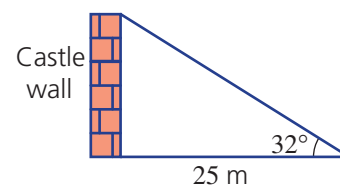

- 6 From a point on the ground, Emma measures the angle of elevation of an 80 m tower to be 27° . Find how far Emma is from the base of the tower, correct to the nearest metre.

Hint: First draw a simple triangle and label your side lengths and given angle.



- 7 From a pedestrian overpass, Chris spots a landmark at an angle of depression of 32° . How far away (to the nearest metre) is the landmark from the base of the 24 m high overpass?

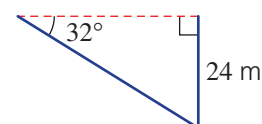

41



- 8 From a lookout tower, David spots a bushfire at an angle of depression of 25° . If the lookout tower is 42 m high, how far away (to the nearest metre) is the bushfire from the base of the tower?

Hint: Be sure to mark in the angle of depression below the horizontal.



Example 23 Finding an angle of depression

From the top of a vertical cliff, Andrea spots a boat out at sea. If the top of the cliff is 42 m above sea level and the boat is 90 m away from the base of the cliff, find Andrea's angle of depression to the boat to the nearest degree.

Solution

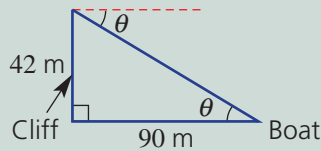

$$\begin{aligned}\tan \theta &= \frac{O}{A} \\ &= \frac{42}{90}\end{aligned}$$

$$\theta = \tan^{-1}\left(\frac{42}{90}\right)$$

$$\theta = 25^\circ \text{ (to nearest degree)}$$

The angle of depression is 25° .

Explanation

Draw a diagram and label all the given measurements. The angle of depression is below the horizontal.

Use alternate angles in parallel lines to mark θ inside the triangle.

Since the opposite (O) and adjacent sides (A) are given, use $\tan \theta$.

Use the \tan^{-1} key on your calculator and round off to the nearest degree.

Express the answer in words.

Now you try

From the top of a lighthouse, a yacht is spotted out at sea. If the top of the lighthouse is 34 m above sea level and the yacht is 120 m away from the base of the lighthouse (at sea level), find the angle of depression from the top of the lighthouse to the yacht to the nearest degree.



- 9 From the top of a vertical cliff, Josh spots a swimmer out at sea. If the top of the cliff is 38 m above sea level and the swimmer is 50 m away from the base of the cliff, find the angle of depression from Josh to the swimmer, to the nearest degree.



Hint: Start with a diagram like this.

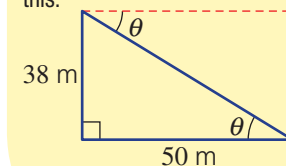

- 10 From a ship, a person is spotted floating in the sea 200 m away. If the viewing position on the ship is 20 m above sea level, find the angle of depression from the ship to the person in the sea. Give your answer to the nearest degree.



Hint: Draw a diagram first. The angle of depression is below the horizontal.



Problem-solving and reasoning

11, 12

11–14

-  **11** A power line is stretched from a pole to the top of a house. The house is 4.1 m high and the power pole is 6.2 m high. The horizontal distance between the house and the power pole is 12 m. Find the angle of elevation of the top of the power pole from the top of the house, to the nearest degree.
-  **12** A road has a steady gradient of 1 in 10. It rises 1 m for every 10 m across.
- What angle does the road make with the horizontal? Give your answer to the nearest degree.
 - A car starts from the bottom of the inclined road and drives 2 km along the road. How high, vertically, has the car climbed? Use your rounded answer from part **a** and give your answer correct to the nearest metre.



-  **13** A house is to be built using the design shown on the right. The eaves are 600 mm and the house is 7200 mm wide, excluding the eaves. Calculate the length (to the nearest mm) of a sloping edge of the roof, which is pitched at 25° to the horizontal.

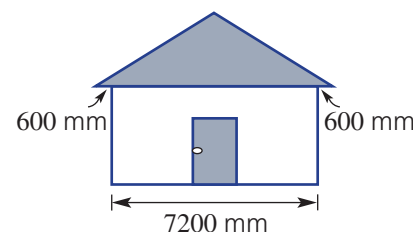

-  **14** A plane flying at 1850 m starts to climb at an angle of 18° to the horizontal when the pilot sees a mountain peak 2450 m high, 2600 m away from him in a horizontal direction. Will the pilot clear the mountain?

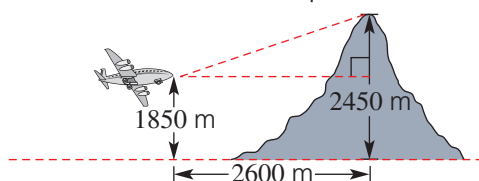

Plane trigonometry

—

15

-  **15** An aeroplane takes off and climbs at an angle of 20° to the horizontal, at 190 km/h along its flight path for 15 minutes.
- Find:
 - the distance the aeroplane travels in 15 minutes
 - the height the aeroplane reaches after 15 minutes correct to two decimal places.
 - If the angle at which the plane climbs is twice the original angle but its speed is halved, will it reach a greater height after 15 minutes?
 - If the plane's speed is doubled and its climbing angle is halved, will the plane reach a greater height after 15 minutes?



Maths@Work: Carpenter

Carpenters work with wood, building house frames, verandahs or decks, kitchen cabinets, built-in wardrobes and so on. They often work outdoors and have to be proficient with tools such as augers, drills, saws, chisels, rulers, squares, compasses and levels.

As with most trades, mathematical skills are used regularly. Carpenters must be able to measure, convert between units, order material and calculate lengths using measuring devices, as well as apply Pythagoras' theorem and trigonometry rules.



- 1 Carpenters work in millimetres as their base unit for measurement of length. Convert each of the following into millimetres.

a 45 cm **b** 2.4 m **c** 9.01 m **d** 270 cm **e** 46.0 m

- 2 A carpenter needs to cut mitred joints to join 4 pieces of wood of equal width to construct a picture frame. A mitre joint is formed when cuts at exactly 45° are made so that two pieces of timber fit together perfectly. Copy the diagram and show how the mitre cuts can be marked out by using isosceles triangles instead of a set square. Shade the final shape of the wood after the cuts are made. The top piece is done for you.

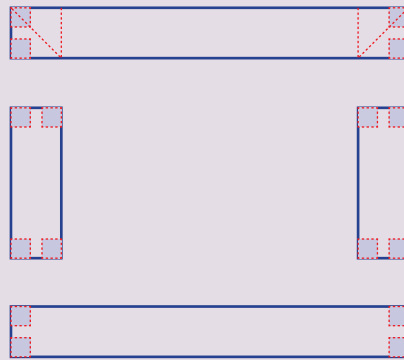

- 3 For each box below, find the minimum dimensions of a single rectangular sheet of plywood required to construct that closed box. Draw and label the least wasteful arrangement of the sides and ignore any overlap for joining. State the answers in millimetres. Diagrams are not to scale. You will need Pythagoras' theorem in part **b**.

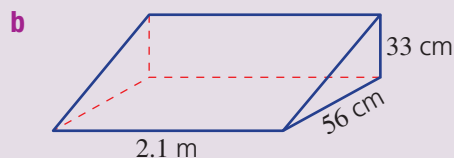
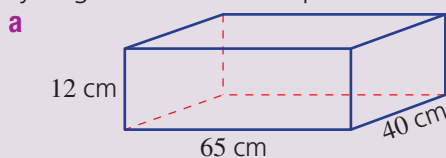

- 4 A carpenter is constructing a set of shelves near the kitchen doorway. To avoid sharp corners and allow more walking space, a 60° triangle is cut from each shelf as shown in this diagram. The carpenter carefully measures AB and BC to achieve the same 60° angle on each shelf.

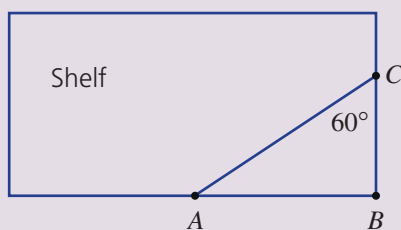

Calculate the unknown length (BC or AB) to the nearest mm, given these measurements.

- a $AB = 125$ mm b $AB = 184$ mm c $BC = 108$ mm d $BC = 210$ mm

Many tradespeople work together constructing a house. Use the measurements on this diagram of a basic house for questions 5, 6 and 7. It is not drawn to scale.

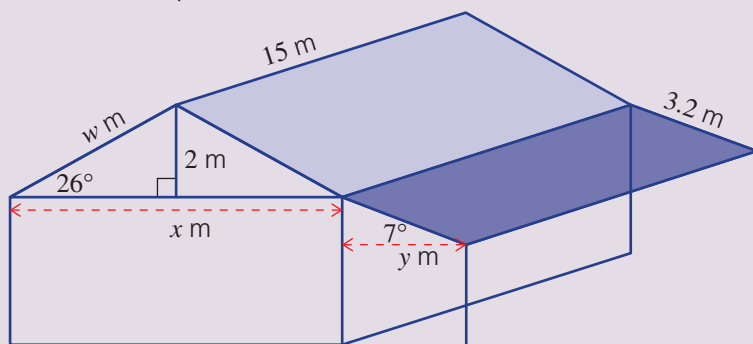

- 5 The house roof is tiled and the verandah has a steel roof. If the builder uses 10 tiles/ m^2 calculate the number of tiles needed for this house, to the nearest 10 tiles. You will need to calculate the value of w .
- 6 The rainfall catchment area of any roof is equal to the ground area that the roof covers. Calculate the total possible rainfall catchment area of this house, to the nearest 10 m^2 .
- 7 The litres of rainfall that a house roof can collect per year is given by the formula:

$$\text{volume of rain in litres} = \text{annual rainfall in mm} \times \text{roof catchment area in } m^2 \times \text{percentage of run-off}$$

Copy and complete the following Excel spreadsheet to calculate the average annual volume of water available from this house situated in various locations around Australia. Use your answer to Question 6 for the catchment area.

Recall that 1 mm of rain over an area of 1 m^2 equals 1 litre of rain.

	A	B	C	D	E
1	Average annual volume of water saved from house roof catchments				
2	Location	Annual average rainfall in mm	Rainfall catchment area in m^2	percentage run-off	Volume of rain in litres
3	Strahan, TAS	1521		90	
4	Melbourne, VIC	620		90	
5	Port Lincoln, SA	508		90	
6	Perth, WA	728		90	
7	Newcastle, NSW	1200		90	
8	Tully, QLD	4105		90	
9	Alice Springs, NT	243		90	

Viewing angle

Lucas is keen to maximise his experience at the outdoor cinema and usually sits at a distance of 20 metres horizontally from the screen. The base of the screen is 3 metres above the ground and the screen is 5 metres in height. Lucas' eye level is 1 metre above ground level as shown.

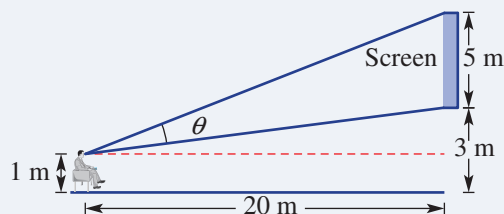

Present a report for the following tasks and ensure that you show clear mathematical workings and explanations where appropriate. Use two decimal places for all rounding.

Preliminary task

- What is the vertical distance between Lucas' eye level and the base of the screen?
- Find the angle of elevation (α) from Lucas' eye level to the base of the screen.

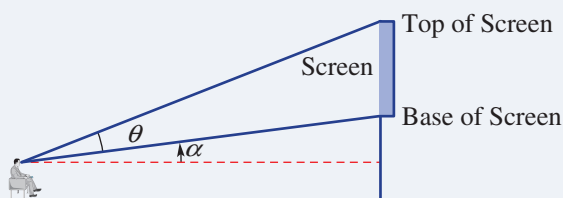

- Find the angle of elevation (β) from Lucas' eye level to the top of the screen.

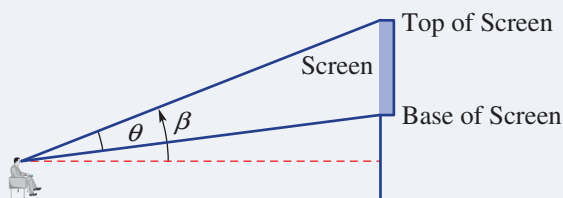

- Find Lucas' viewing angle (θ).

Modelling task

The problem is to determine how close Lucas should sit to maximise his viewing angle.

- Write down all the relevant information that will help solve this problem, and illustrate using diagrams.
-
- Determine Lucas' viewing angle if the 20 metre horizontal distance is changed to:
 - 14 metres
 - 8 metres
 - 2 metres.
 - Choose integer values for the horizontal distance between Lucas and the screen and determine which integer horizontal distance delivers the largest viewing angle and state the corresponding viewing angle.
-
- Find the viewing angle for the following horizontal distances:
 - your answer from part **c** plus 0.1 metres
 - your answer from part **c** minus 0.1 metres.
 - Do your results from part **d** confirm that you have found a distance which maximises the viewing angle? Explain why.
 - Refine your choices for the horizontal distance and determine a distance correct to one decimal place that maximises Lucas' viewing angle.

g Summarise your results into a spreadsheet, like the one below.

	A	B	C	D	E	F
1	distance	h_1	α	h_2	β	θ
2	20	2		7		
3						
4						

h Draw a scale diagram illustrating where Lucas should sit to maximise his viewing angle. Decide if this position for Lucas is reasonable.

Extension question

a If the screen is lowered to 2 metres above the ground, rather than the current height of 3 metres, investigate how this changes the position that Lucas should sit to maximise his viewing angle.



- 1 How many right-angled triangles are there in this diagram?

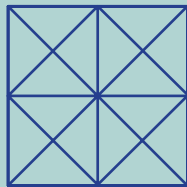

- 2 Look at this right-angled triangle and the squares drawn on each side. Each square is divided into smaller sections.

- a Can you see how the parts of the two smaller squares would fit into the larger square?
- b What is the area of each square if the side lengths of the right-angled triangle are a , b and c as marked?
- c What do the answers to the above two questions suggest about the relationship between a , b and c ?

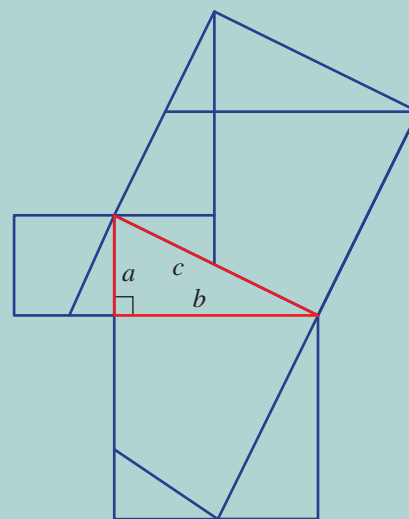

- 3 Imagine trying to cut the largest square from a circle of a certain size and calculating the side length of the square.

- a If the circle has a diameter of 2 cm, can you find a good position to draw the diameter that also helps to form a right-angled triangle?
- b Can you determine the side length of the largest square if the circle has a diameter of 2 cm?
- c What percentage of the area of a circle does the largest square occupy?

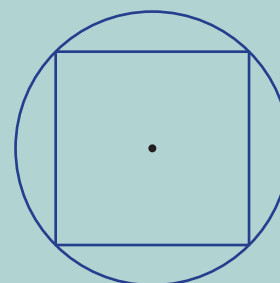

- 4 Which is a better fit: a square peg in a round hole or a round peg in a square hole? Use area calculations and percentages to investigate.

- 5 Two circles of radius 10 cm and 15 cm respectively are placed inside a square. Find the perimeter of the square to the nearest centimetre.

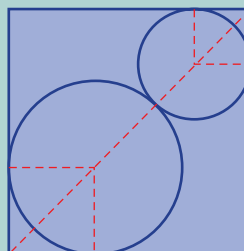

Hint: First find the diagonal length of the square using the diagram shown.



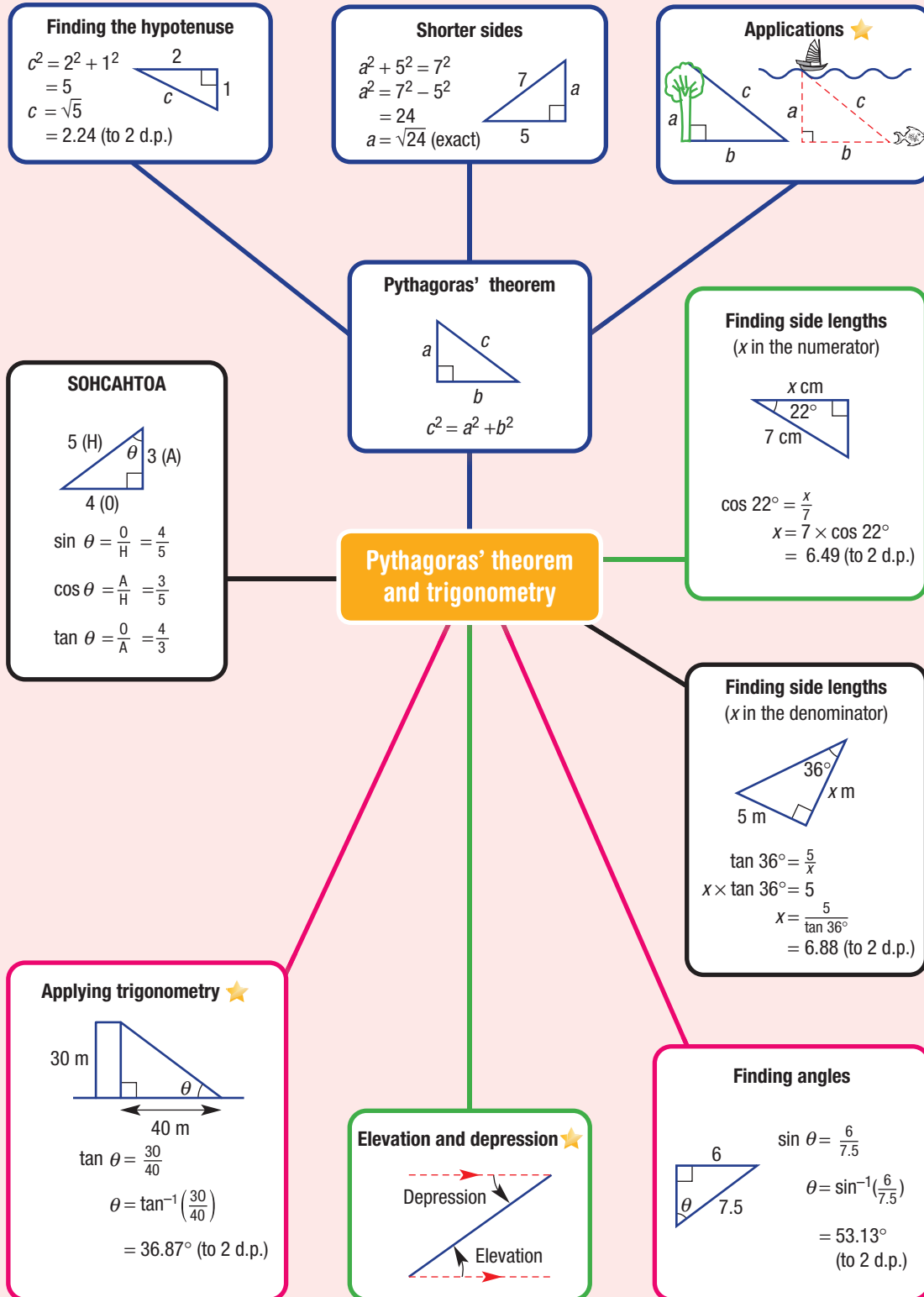

Chapter checklist

A version of this checklist that you can print out and complete can be downloaded from your Interactive Textbook.

4A

1 I can write Pythagoras' theorem for a right-angled triangle.

e.g. Write down Pythagoras' theorem for these triangles

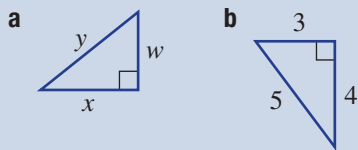

4B

2 I can find the length of the hypotenuse.

e.g. Find the length of the hypotenuse in these right-angled triangles, rounding to two decimal places where necessary.

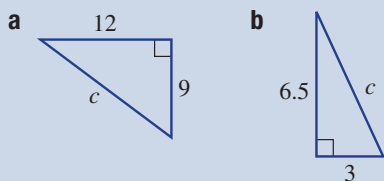

4B

3 I can find the length of the hypotenuse as a surd.

e.g. Find the length of the hypotenuse in this right-angled triangle, leaving your answer as an exact value.

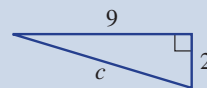

4C

4 I can find the length of a shorter side.

e.g. Find the value of the pronumeral, rounding to two decimal places.

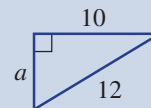

4C

5 I can find the exact length of a shorter side in a right isosceles triangle.

e.g. Find the value of x , giving your answer as a surd.

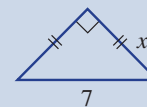

4D

6 I can identify right-angled triangles in a diagram to find unknown lengths.

e.g. An apartment courtyard is in the shape of a trapezium, as shown. Find the unknown side length correct to two decimal places by first drawing a suitable right-angled triangle.

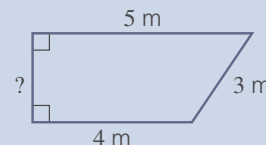

4D

7 I can apply Pythagoras' theorem.

e.g. Two poles are 10 m apart. The heights of the poles are 8 m and 12 m. If a bird flies from the top of one pole in a direct line to the top of the other pole, how far does the bird fly correct to two decimal places?

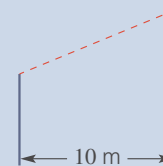

4E

8 I can label the sides of a triangle.

e.g. Copy this triangle and label the sides as opposite to θ (O), adjacent to θ (A) and hypotenuse (H).

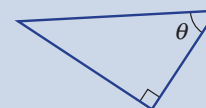



4E

9 I can write trigonometric ratios for right-angled triangles.

e.g. Write a trigonometric ratio (in fraction form) for each of the following triangles.

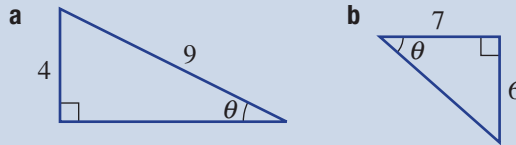

4F

10 I can find trigonometric values on a calculator.e.g. Use a calculator to evaluate $\tan 35^\circ$ correct to two decimal places.

4F

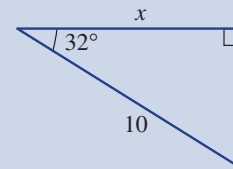
11 I can find an unknown side length using trigonometry.e.g. Find the value of x in the triangle correct to two decimal places.

4G

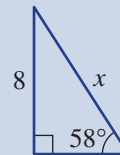
12 I can find an unknown side length in the denominator of a trigonometric ratio.e.g. Find the value of x correct to two decimal places.

4G

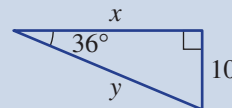
13 I can find two side lengths using trigonometry.e.g. Find the value of x and y correct to two decimal places.

4H

14 I can use inverse trigonometric ratios.e.g. Find the value of θ to the nearest degree if:

a $\cos \theta = 0.6261$ **b** $\sin \theta = \frac{3}{7}$.

4H

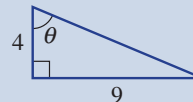
15 I can find an angle using trigonometry.e.g. Find the value of θ to the nearest degree.

4I

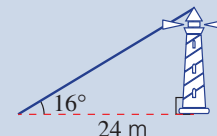
16 I can use angles of elevation.e.g. The angle of elevation of the top of a light tower from a point on the ground 24 m away from the base of the tower is 16° . Find the height of the light tower to the nearest metre.

4I

17 I can work with angles of depression.

e.g. From the surface of the water, a snorkeller spots a ray below the water. If the surface of the water is 3 m above the ray and the ray is 5 m horizontally from the snorkeller, find the angle of depression from the snorkeller to the ray to the nearest degree.

Short-answer questions

- 4A 1** Write down Pythagoras' theorem for these triangles, using the given pronumerals.

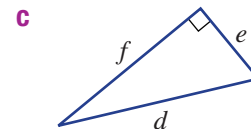
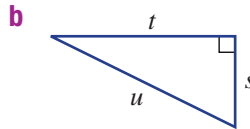
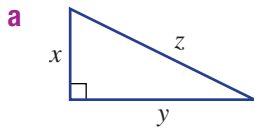

- 4B 2** Find the length of the hypotenuse in these triangles. Round to two decimal places where appropriate.

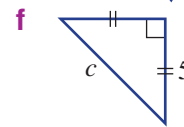
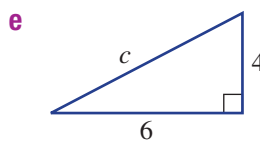
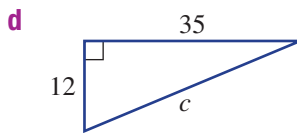
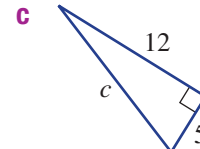
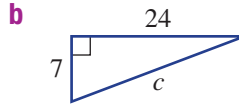
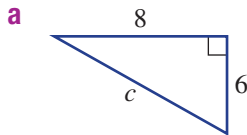

- 4C 3** Find the length of the unknown side in these right-angled triangles. Round to two decimal places.

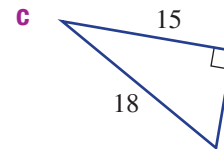
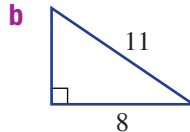
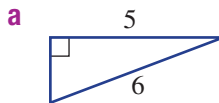

- 4D 4** A steel support beam of length 6.5 m is connected to a wall at a height of 4.7 m from the ground. Find the distance (to two decimal places) between the base of the building and the point where the beam is joined to the ground.

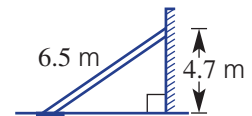

- 4D 5** For this double triangle, find:



- a** the length AC
b the length CD (correct to two decimal places)

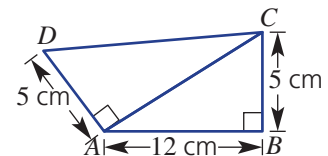

- 4D 6** Two different cafés on opposite sides of an atrium in a shopping centre are respectively 10 m and 15 m above the ground floor. If the cafés are linked by a 20 m escalator, find the horizontal distance (to the nearest metre) across the atrium, between the two cafés.



- 4E 7** Find the value of each of the following, correct to two decimal places.



- a** $\sin 40^\circ$ **b** $\tan 66^\circ$ **c** $\cos 44^\circ$

- 4E** **8** Which ratio ($\sin \theta = \frac{O}{H}$, $\cos \theta = \frac{A}{H}$ or $\tan \theta = \frac{O}{A}$) would be used to find the value of the unknown in these triangles?

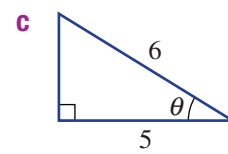
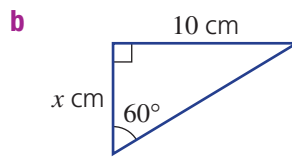
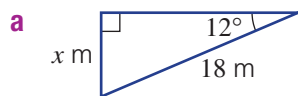

- 4F/G/H** **9** Find the value of each pronumeral, correct to two decimal places where necessary. Use $\sin \theta = \frac{O}{H}$, $\cos \theta = \frac{A}{H}$ or $\tan \theta = \frac{O}{A}$.

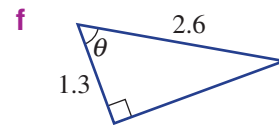
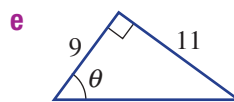
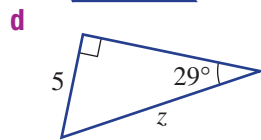
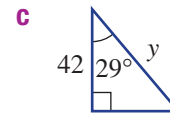
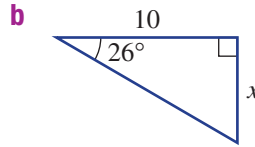
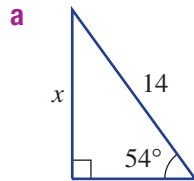

- 4I** **10** The angle of elevation of the top of a lighthouse from a point on the ground 40 m from its base is 35° . Find the height of the lighthouse, to two decimal places.

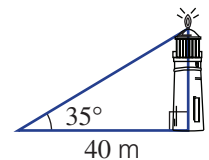

- 4I** **11** A train travels up a slope, making an angle of 7° with the horizontal. When the train is at a height of 3 m above its starting point, find the distance it has travelled up the slope, to the nearest metre.

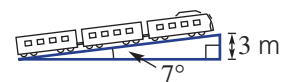

- 4I** **12** From a point on the ground, Ahbed measures the angle of elevation of a 120 m tower to be 34° . How far from the base of the tower is Ahbed, correct to two decimal places?



- 4I** **13** Aisha is standing on the roof of a skyscraper when she spots a car at an angle of depression of 51° below her. If the skyscraper is 78 m high, how far away is the car from the base of the skyscraper, correct to one decimal place?

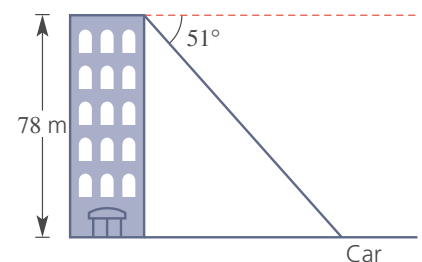

Multiple-choice questions

- 4A** **1** For the right-angled triangle shown, which is a correct statement?

- A** $c^2 = 5^2 + 12^2$ **B** $c^2 = 5^2 - 12^2$ **C** $c^2 = 12^2 - 5^2$
D $c^2 = 5^2 \times 12^2$ **E** $(5 + 12)^2$

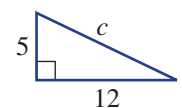

- 4A** **2** Which of the following is true for this triangle?

- A** $a = 5 - 4$ **B** $a^2 = 5^2 - 4^2$ **C** $a^2 = 5^2 + 4^2$
D $a = \sqrt{10}$ **E** $a^2 - 4^2 = 5^2$

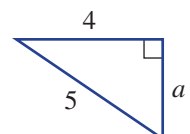

4C 3 For the right-angled triangle shown, which is a correct statement.

A $2x^2 = 49$

B $7x^2 = 2$

C $2x^2 = 7$

D $x^2 + 7^2 = x^2$

E $x^2 = \frac{2}{7}$

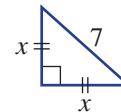

4E 4 For the triangle shown, which is a correct statement.

A $\sin \theta = \frac{a}{b}$

B $\sin \theta = \frac{c}{a}$

C $\sin \theta = \frac{a}{c}$

D $\sin \theta = \frac{b}{c}$

E $\sin \theta = \frac{c}{b}$

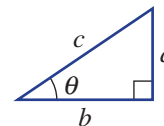

4E 5 The value of $\cos 46^\circ$, correct to four decimal places, is:



A 0.7193

B 0.6947

C 0.594

D 0.6532

E 1.0355

4F 6 In the diagram, the value of x , correct to two decimal places, is:



A 40

B 13.61

C 4.70

D 9.89

E 6.47

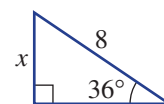

4G 7 The value of x in the triangle is given by:

A $8 \sin 46^\circ$

B $8 \cos 46^\circ$

C $\frac{8}{\cos 46^\circ}$

D $\frac{8}{\sin 46^\circ}$

E $\frac{\cos 46^\circ}{8}$

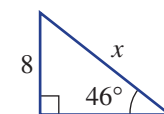

4H 8 The value of θ in this triangle is given by:

A $\tan\left(\frac{4}{5}\right)$

B $\tan\left(\frac{5}{4}\right)$

C $\tan^{-1}\left(\frac{5}{4}\right)$

D $\sin^{-1}\left(\frac{4}{5}\right)$

E $\tan^{-1}\left(\frac{4}{5}\right)$

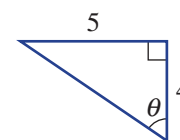

4I 9 A ladder is inclined at an angle of 28° to the horizontal. If the ladder reaches 8.9 m up the wall, the length of the ladder correct to the nearest metre is:



A 19 m

B 4 m

C 2 m

D 10 m

E 24 m



4H 10 The value of θ in the diagram, correct to two decimal places, is:



A 0.73°

B 48.19°



C 41.81°

D 33.69°

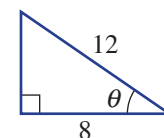

E 4.181°



Extended-response questions

-   **1** From the top of a 100 m cliff, Skevi sees a boat out at sea at an angle of depression of 12° .
- Draw a simple diagram for this situation.
 - Find how far out to sea the boat is to the nearest metre.
 - A swimmer is 2 km away from the base of the cliff and in line with the boat. What is the angle of depression to the swimmer to the nearest degree?
 - How far away is the boat from the swimmer, to the nearest metre?



-   **2** An extension ladder is initially placed so that it reaches 2 metres up a wall. The foot of the ladder is 80 centimetres from the base of the wall.
- Find the length of the ladder, to two decimal places, in its original position.
 - Without moving the foot of the ladder, it is extended so that it reaches 1 m further up the wall. How far (to two decimal places) has the ladder been extended?
 - The ladder is placed so that its foot is now 20 cm closer to the base of the wall. How far up the wall can the ladder length found in part **b** reach? Round to two decimal places.

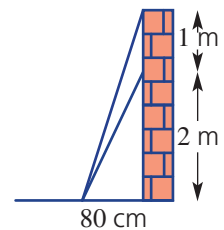

Chapter 5

Linear relations

Essential mathematics: why skills with linear relations are important

Skills using linear relations are widely applied to solve problems in many trades, scientific research, manufacturing and finance.

- Linear relationships in direct proportion have graphs through $(0, 0)$. For example:
 - weekly pay = $\$/h \times$ number of hours
 - crop spray in kg = $\text{kg/acre} \times$ number of acres
 - $\$/\text{AUD} =$ exchange rate \times foreign currency amount
- Builders of wheelchair ramps apply the gradient regulation of the Australian Building Code.

This requires a maximum gradient = $\frac{1}{14}$, i.e. a 1 m rise for every 14 m of horizontal run.

- Industrial robots are programmed to calculate the length and midpoint of a virtual straight line segment joining two points in 3D having coordinates (x, y, z) .
- A second-hand car bought for \$12 000 can cost \$4000 p.a. to run, e.g. for fuel, repairs, registration and insurance. The total cost, C , over n years, is then modelled with the rule $C = 4000n + 12\,000$.



In this chapter

- 5A Introduction to linear relations
- 5B Finding x - and y -intercepts
- 5C Graphing straight lines using intercepts
- 5D Lines with one intercept
- 5E Gradient
- 5F Gradient and direct proportion
- 5G Gradient–intercept form
- 5H Finding the equation of a line ★
- 5I Midpoint and length of a line segment
- 5J Linear modelling ★
- 5K Non-linear graphs

Australian Curriculum

NUMBER AND ALGEBRA

Linear and non-linear relationships

Find the distance between two points located on the Cartesian plane using a range of strategies, including graphing software (ACMNA214)

Find the midpoint and gradient of a line segment (interval) on the Cartesian plane using a range of strategies, including graphing software (ACMNA294)

Sketch linear graphs using the coordinates of two points and solve linear equations (ACMNA215)

Graph simple non-linear relations with and without the use of digital technologies and solve simple related equations (ACMNA296)

© Australian Curriculum, Assessment and Reporting Authority (ACARA)

Online resources

A host of additional online resources are included as part of your Interactive Textbook, including HOTmaths content, video demonstrations of all worked examples, auto-marked quizzes and much more.

1 Plot and label the following points on a Cartesian plane (x - and y - axes).

a (3, 1)

b (-2, 4)

c (0, 0)

d (5, -3)

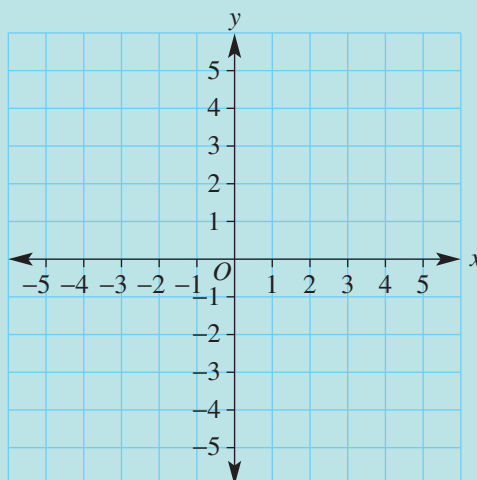

2 Given $y = x - 2$, find the value of y . when:

a $x = 3$

b $x = 1$

c $x = -1$

d $x = -2$

3 Solve the following equations for x .

a $3x = 15$

b $-2x = 4$

c $-x = 3$

d $0 = x - 4$

e $0 = 3x + 6$

f $0 = 2x - 8$

4 Find the value of y in each of the following when $x = 0$.

a $y = 2x + 3$

b $y = 3x - 4$

c $x + 2y = 8$

d $3x - 4y = 12$

5 Complete the table of values for these rules.

a $y = x + 3$

b $y = 2x - 1$

	x	-2	-1	0	1	2
a	y					
b	y					

6 If $x = 2$ and $y = 1$, decide whether the following equations are true.

a $y = 2x + 1$

b $y = 3x - 5$

c $y = -2x + 5$

d $5x - 2y = 6$

7 Simplify:

a $\frac{4+10}{2}$

b $\frac{2+11}{2}$

c $\frac{-1+7}{2}$

d $\frac{-3+(-7)}{2}$

8 Find the vertical distance between the following pairs of points.

a (3, 2) and (3, 7)

b (-1, 1) and (-1, -3)

c (2, 3) and (2, -2)

d (1, -4) and (1, -1)

9 Find the horizontal distance between the following pairs of points.

a (1, 3) and (5, 3)

b (-1, 2) and (4, 2)

c (-2, -3) and (5, -3)

d (-4, 1) and (-1, 1)

5A Introduction to linear relations

Learning intentions

- To review the features of the Cartesian plane
- To know that a linear relation is a set of coordinates that form a straight line when graphed
- To be able to complete a table of values and plot points to form a linear graph
- To know the general forms of a linear relation
- To understand that for a point to be on a line its coordinates must satisfy the rule for the linear relation
- To be able to decide if a point is on a line using its rule

Key vocabulary: Cartesian plane, x -axis, y -axis, linear relation, coordinates (or coordinate pair), origin, x -coordinate, y -coordinate

If two variables are related in some way, we can use mathematical rules to more precisely describe this relationship. The most simple type of relationship is one that can be illustrated with a straight line graph. These are called linear relations.

The volume of petrol in your car at a service bowser, for example, might initially be 10 L, then increase by 1.2 L per second after that. This is an example of a linear relationship between *volume* and *time* because the volume is increasing at a constant rate of 1.2 L/s.



Lesson starter: Is it linear?

Here are three rules linking x and y .

1 $y_1 = \frac{2}{x} + 1$

2 $y_2 = x^2 - 1$

3 $y_3 = 3x - 4$

First complete this simple table and plot the points on the graph.

x	1	2	3
y_1			
y_2			
y_3			

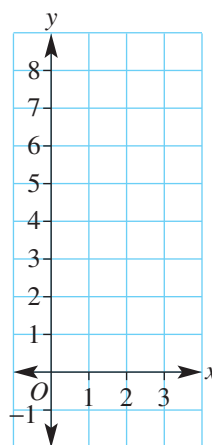

- Which of the three rules do you think is linear?
- How do the table and graph help you decide it's linear?

Key ideas

- Coordinate geometry provides a link between geometry and algebra.
- The **Cartesian plane** (or number plane) consists of two axes that divide the number plane into four quadrants.
 - The **x-axis** is the horizontal axis.
 - The **y-axis** is the vertical axis.
 - The x-axis and y-axis intersect at the **origin** (O) at right angles.
 - A point is precisely positioned on a Cartesian plane using the **coordinate pair** (x, y) .
 x (the **x-coordinate**) describes the horizontal position of the point from the origin.
 y (the **y-coordinate**) describes the vertical position of the point from the origin.

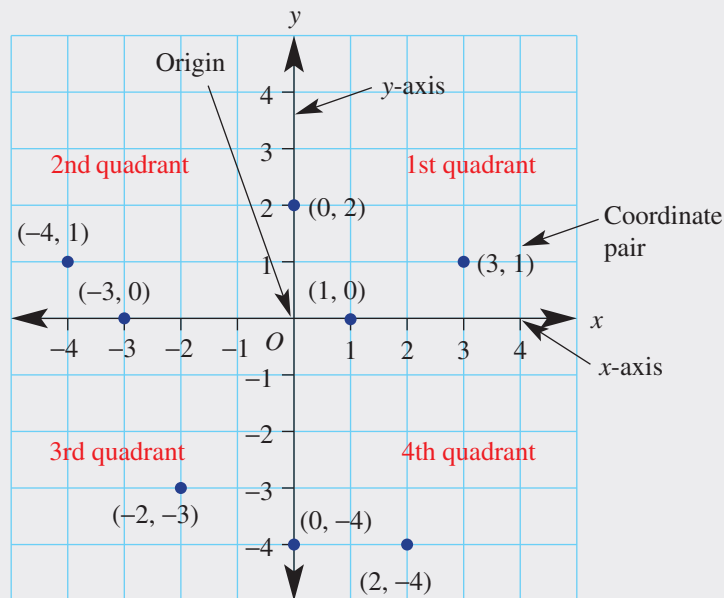

- In the coordinate pair $(2, -4)$, 2 is the x-coordinate and -4 is the y-coordinate. The point is 2 units to the right of the origin (horizontal direction) and 4 units below the origin (vertical direction).
- A **linear relation** is a set of ordered pairs (x, y) that, when graphed, give a straight line.
- Linear relations have rules that may be of the form:
 - $y = mx + c$ (or $y = mx + b$), for example, $y = 2x + 1$
 - $ax + by = d$ or $ax + by + c = 0$, for example, $2x - 3y = 4$ or $2x - 3y - 4 = 0$
- Each point that is on the line fits the rule for the linear relation. For example, on the line with rule $y = 2x$, each y-coordinate will be two times the x-coordinate. So, $(3, 6)$ will be on the line but $(4, 10)$ will not.

Exercise 5A

Understanding

1–4

2, 4

- 1 a** For the Cartesian plane shown, label the following parts.
- x -axis
 - origin
 - y -axis
 - coordinate pair
- b** For the point $(3, -1)$:
- 3 is the _____.
 - 1 is the _____.
 - From the origin, the point is 3 units to the _____ and 1 unit _____.

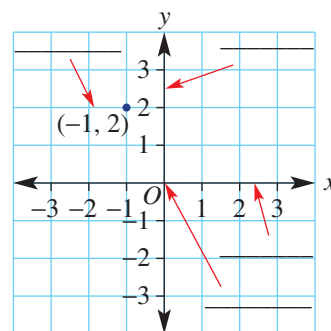

- 2** Refer to the Cartesian plane shown.
- a** Draw this set of axes (without $A-F$) and plot the following points.
- $(3, 1)$
 - $(-4, -2)$
 - $(0, 2)$
 - $(-1, 2)$
- b** Give the coordinates of all the points $A-F$.

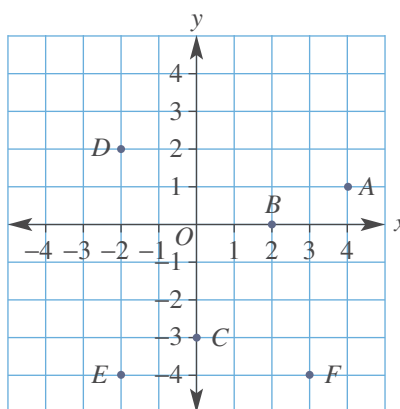

Hint: List the x -coordinate followed by the y -coordinate; e.g. $(2, 4)$



- 3** Which one of the following rules is linear?
- A** $y = x^2 + 4$ **B** $y = \frac{2}{x}$ **C** $y = 2x - 1$ **D** $y = 3^x$
- 4** In the rule $y = 3x$, the y -coordinate of each point on the line is 3 times the x -coordinate. Which point(s) lie on this line?
- A** $(1, 3)$ **B** $(3, 6)$ **C** $(-3, -9)$ **D** $(-1, 3)$

Hint: Linear rules are often in the form $y = mx + c$ or $ax + by = d$.



Fluency

5, 6

5, 6



Example 1 Filling in tables from rules

Complete the tables for the given rules.

a $y = 2x - 1$

x	-2	-1	0	1	2	3
y						

b $y = -3x + 2$

x	-2	-1	0	1	2
y					

Continued on next page

Solution

a $y = 2x - 1$

x	-2	-1	0	1	2	3
y	-5	-3	-1	1	3	5

b $y = -3x + 2$

x	-2	-1	0	1	2
y	8	5	2	-1	-4

Explanation

Substitute each x value in the table into the rule $y = 2x - 1$ to find its corresponding y value.

$$\begin{aligned} \text{For } x = -2, y &= 2 \times (-2) - 1 \\ &= -4 - 1 \\ &= -5 \end{aligned}$$

$$\begin{aligned} \text{For } x = 1, y &= 2 \times 1 - 1 \\ &= 2 - 1 \\ &= 1 \end{aligned}$$

Substitute each x value into the rule $y = -3x + 2$. Recall that negative \times negative = positive.

$$\begin{aligned} \text{For } x = -2, y &= -3 \times (-2) + 2 \\ &= 6 + 2 \\ &= 8 \end{aligned}$$

$$\begin{aligned} \text{For } x = 0, y &= -3 \times 0 + 2 \\ &= 0 + 2 \\ &= 2 \end{aligned}$$

Now you try

Complete the table for the given rules.

a $y = 3x - 2$

b $y = -2x + 4$

x	-2	-1	0	1	2
y					

5 Complete the tables for the given rules.

a $y = x + 2$

x	-2	-1	0	1	2	3
y						

b $y = 2x + 3$

x	-2	-1	0	1	2
y					

c $y = -2x$

x	-2	-1	0	1	2
y					

d $y = -3x - 1$

x	-2	-1	0	1	2	3
y						

Hint: A negative \times positive is negative.
A negative \times negative is positive.





Example 2 Plotting points to graph straight lines

Using $-3 \leq x \leq 3$, construct a table of values and plot a graph for these linear relations.

a $y = x + 2$

b $y = -2x + 2$

Solution

a

x	-3	-2	-1	0	1	2	3
y	-1	0	1	2	3	4	5

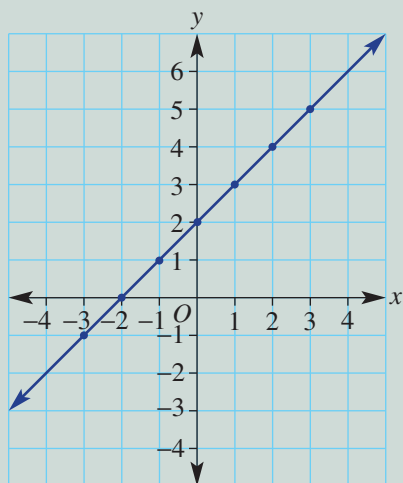

b

x	-3	-2	-1	0	1	2	3
y	8	6	4	2	0	-2	-4

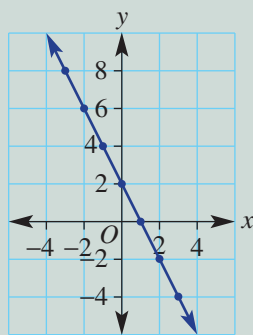

Explanation

Use $-3 \leq x \leq 3$ to construct a table of x values as instructed. Substitute each value of x into the rule $y = x + 2$.

The coordinates of the points are read from the table; i.e. $(-3, -1)$, $(-2, 0)$ etc.

Draw a set of axes with an appropriate scale to show the points from the table.

Plot each point and join to form a straight line.

Extend the line to show it continues in either direction.

Use $-3 \leq x \leq 3$ as instructed. Substitute each value of x into the rule $y = -2x + 2$.

Plot each point and join to form a straight line.

Extend the line beyond the plotted points.

Now you try

Using $-3 \leq x \leq 3$, construct a table of values and plot a graph for these linear relations.

a $y = x - 2$

b $y = -3x + 4$

6 Using $-3 \leq x \leq 3$, construct a table of values and plot a graph for these linear relations.

a $y = x - 1$

b $y = x + 3$

c $y = 2x - 3$

d $y = -3x$

e $y = -2x - 1$

f $y = -x + 4$



Example 3 Deciding whether a point is on a line

Decide whether the point $(3, 7)$ is on the line with the given rule.

a $y = 3x - 4$

b $y = 2x + 1$

Solution

Explanation

a $y = 3x - 4$

Substitute $x = 3$

$$y = 3 \times 3 - 4$$

$$= 5 \text{ (not 7)}$$

\therefore the point $(3, 7)$ is not on the line

Find the value of y on the graph of the rule for $x = 3$.

To fit the rule, the y value needs to be 5, not 7, so $(3, 7)$ is not on the line.

b $y = 2x + 1$

Substitute $x = 3$

$$y = 2 \times 3 + 1$$

$$= 7$$

\therefore the point $(3, 7)$ is on the line

By substituting $x = 3$ into the rule for the line, we find $y = 7$.

Since $(3, 7)$ fits the rule, it is on the line.

Now you try

Decide whether the point $(2, 10)$ is on the line with the given rule.

a $y = 2x + 6$

b $y = 5x - 4$

7 Decide whether the point $(2, 8)$ is on the line with the given rule.

a $y = 2x + 6$

b $y = 3x + 2$

c $y = -x + 6$

Hint: When $x = 2$, does $y = 8$?



8 Decide whether the point $(-1, 4)$ is on the line with the given rule.

a $y = x + 5$

b $y = -2x + 2$

c $y = 4x$

9 Find a rule in the form $y = mx + c$ (e.g. $y = 2x - 1$) that matches these tables of values.

a

x	0	1	2	3	4
y	2	3	4	5	6

b

x	0	1	2	3
y	0	2	4	6

c

x	-2	-1	0	1	2	3
y	-3	-1	1	3	5	7

d

x	-2	-1	0	1	2	3
y	-7	-4	-1	2	5	8

e

x	-1	0	1	2	3	4
y	-3	-2	-1	0	1	2

Hint: Think about how you can find the y value from the x value. Is it double the x value each time or 3 more than the x value each time? etc.



- 10 The table below shows the recorded height, y cm, of a seedling x days after it sprouts. Find a linear rule in the form $y = \dots$ that matches the data in the table.

x (day)	1	2	3	4
y (height)	3	6	9	12



- 11 By considering the relationship between the coordinates, match these rules **i**, **ii**, **iii** and **iv** to the graphs **a**, **b**, **c** and **d**.

i $y = 2x + 1$

ii $y = -x - 1$

iii $y = -2x + 3$

iv $x + y = 2$

a

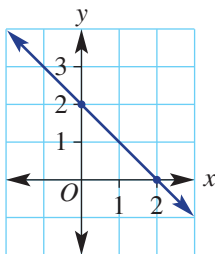

b

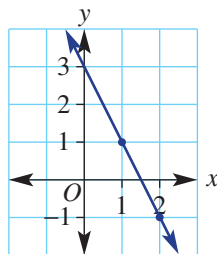

c

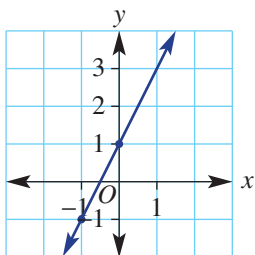

d

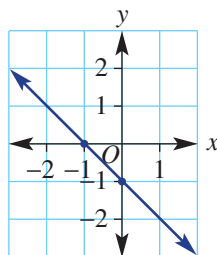

Hint: Each rule shows the relationship between the x - and y -coordinates for each point on the line. In **i**, each y -coordinate has to be 1 more than twice its x -coordinate.



Tougher rule finding

12

- 12 Find the linear rule linking x and y in these tables.

a

x	-1	0	1	2	3
y	5	7	9	11	13

b

x	-2	-1	0	1	2
y	22	21	20	19	18

c

x	1	3	5	7	9
y	1	5	9	13	17

d

x	6	7	8	9	10
y	4	4.5	5	5.5	6

e

x	0	2	4	6	8
y	4	-2	-8	-14	-20

f

x	-5	-4	-3	-2	-1
y	-21	-16	-11	-6	-1

5B Finding x - and y -intercepts

Learning intentions

- To know which points are represented by the x -intercept and y -intercept
- To be able to identify the x -intercept and y -intercept from a table or graph
- To know how to find the x -intercept and the y -intercept of a linear relation

Key vocabulary: x -intercept, y -intercept, coordinates, x -axis, y -axis

Each point on a line satisfies a rule for a linear relation. When the linear relation is a model for a real situation, each point gives a piece of information about that situation. Some points are very significant.

For example, the graph below for the linear relation $y = -0.2x + 40$ models how much petrol a car uses. The y -axis shows the amount of petrol in the tank and the x -axis shows the number of kilometres travelled. The coordinate pair $(50, 30)$ shows that after travelling 50 km, 30 litres of petrol are left in the tank.

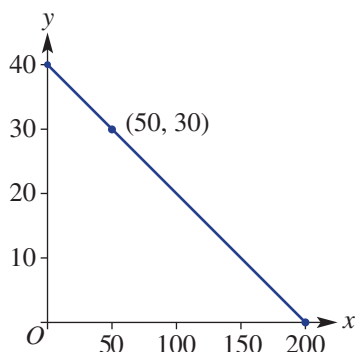

One important point shows us how much petrol was in the tank before the car has started the journey. Using the linear relation (substituting $x = 0$), we can see that this point is $(0, 40)$. This is where the graph cuts the y -axis and is called the y -intercept.

We also want to know when the car will run out of petrol. Again using the linear relation (substituting $y = 0$), we can see that this point is $(200, 0)$. This is where the graph cuts the x -axis and is called the x -intercept.

→ Lesson starter: Are we there yet?

This table shows the distance (y metres) a student is from his home (at x minutes) when he rides his bike home from school.

x	0	2	4	6	8	10
y	2000	1600	1200	800	400	0

- Copy the axes shown and plot these points to form a line.
- How far is school from home?
- How long does it take to get home?
- Circle the above two points on the graph.
- Which point is the x -intercept? Which point is the y -intercept?
- If the rule for the table is $y = -200x + 2000$, how could you find the x - and y -intercepts without sketching the graph?

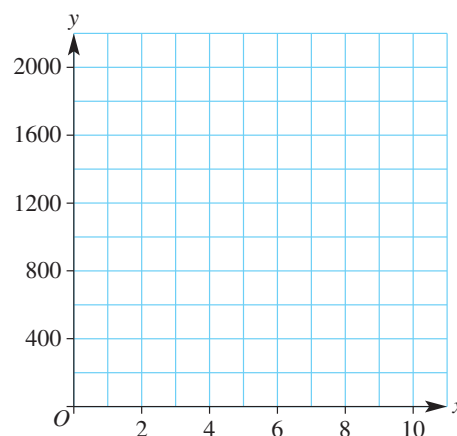

Key ideas

- The **y -intercept** is the point where the line cuts (intersects) the y -axis. It always has an x -coordinate of 0.
- The **x -intercept** is the point where the line cuts (intersects) the x -axis. It always has a y -coordinate of 0.

			x -intercept			
x	-2	-1	0	1	2	3
y	8	6	4	2	0	-2
			y -intercept			

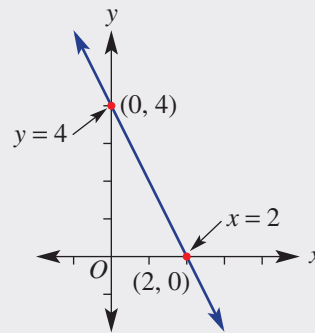

- The rule of the linear relation can be used to find the x - and y -intercepts.
 - To find the y -intercept, substitute $x = 0$ into the rule, since it lies on the y -axis.
 - To find the x -intercept, substitute $y = 0$ into the rule, since it lies on the x -axis.

Exercise 5B

Understanding

1-3

1, 3

- Fill in the missing part of these sentences. Choose from x -intercept, x -coordinate or x -axis.
 - The x -intercept is the point where the graph cuts the _____.
 - The _____ of the y -intercept is always 0.
 - The point on a line with coordinates $(4, 0)$ is the _____.
- For the Cartesian plane shown:
 - give the coordinates of each point that is on the x -axis
 - give the coordinates of each point that is on the y -axis

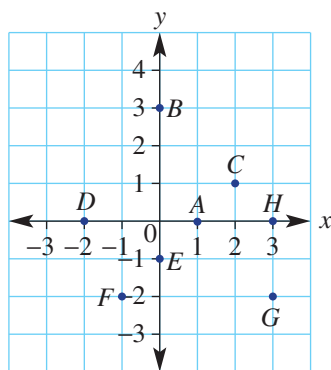

- Copy and complete the following
 - The x -intercept is found in a rule by substituting _____.
 - The y -intercept is found in a rule by substituting _____.

Hint:

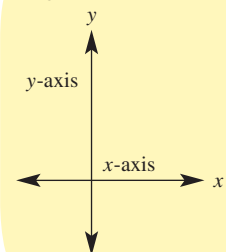

5B

Fluency

4, 5, 6(½)

4–6(½)

Example 4 Reading off the x -intercept and y -intercept

Read off the x -intercept and y -intercept from this table and graph.

a

x	-2	-1	0	1	2	3
y	12	9	6	3	0	-3

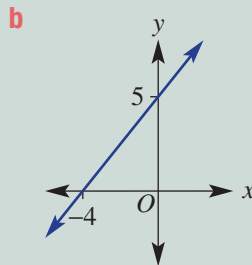

Solution

Explanation

a The x -intercept is 2.
The y -intercept is 6.

The x -intercept is at the point where $y = 0$ (on the x -axis).
The y -intercept is at the point where $x = 0$ (on the y -axis).

b The x -intercept is -4 .
The y -intercept is 5.

The x -intercept is at the point on the x axis ($y = 0$).
The y -intercept is at the point on the y axis ($x = 0$).

Now you try

Read off the x -intercept and y -intercept from this table and graph.

a

x	-2	-1	0	1	2	3
y	-2	0	2	4	6	8

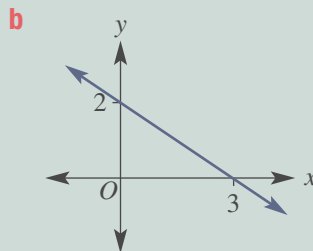

4 Read off the x - and y -intercepts from these tables and graphs.

a

x	-3	-2	-1	0	1	2	3
y	4	3	2	1	0	1	2

b

x	-3	-2	-1	0	1	2	3
y	-1	0	1	2	3	4	5

c

x	-1	0	1	2	3	4
y	10	8	6	4	2	0

d

x	-5	-4	-3	-2	-1	0
y	0	2	4	6	8	10

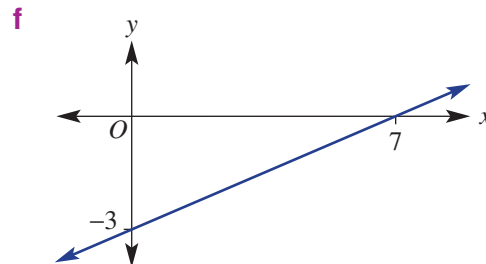
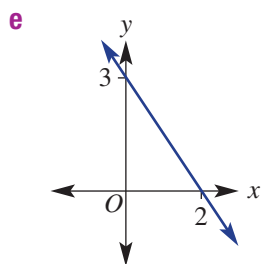

Hint: The x -intercept is where $y = 0$.
The y -intercept is where $x = 0$.



g

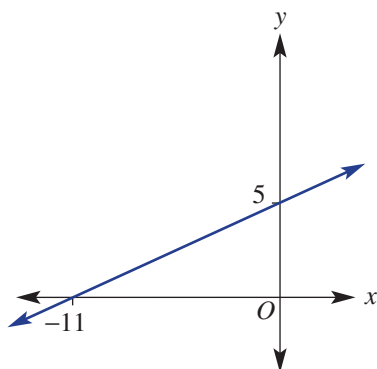

h

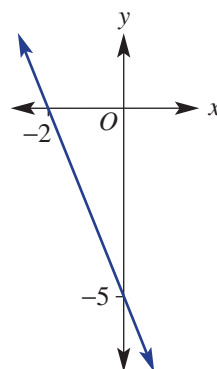

Example 5 Finding the y -intercept

Find the y -intercept for these linear relations.

a $y = 2x - 1$

b $2x + 3y = 6$

Solution

a $y = 2x - 1$
 y -intercept (let $x = 0$):
 $y = 2 \times (0) - 1$
 $= -1$
 the y -intercept is -1

b $2x + 3y = 6$
 y -intercept (let $x = 0$):
 $2 \times (0) + 3y = 6$
 $3y = 6$
 $y = 2$
 the y -intercept is 2

Explanation

Substitute $x = 0$ into the rule to find the y value of the y -intercept.

Recall that anything multiplied by 0 is 0.

Using coordinates the y -intercept is at $(0, -1)$.

Substitute $x = 0$ to find the y -intercept.

Solve the equation $3y = 6$ by dividing both sides by 3.

Using coordinates the y -intercept is at $(0, 2)$.

Now you try

Find the y -intercept for these linear relations.

a $y = 3x + 5$

b $3x + 4y = 12$

5 Find the y -intercept for these linear relations.

a $y = 2x + 5$

b $y = 3x + 1$

c $y = x - 7$

d $y = 2x - 3$

e $y = -4x + 2$

f $y = -5x - 4$

g $y = -x - 2$

h $y = -2x + 10$

i $2x + y = 11$

j $2x + 3y = 9$

k $x + 4y = 8$

l $-3x + 2y = 12$

m $4x - 2y = 6$

n $3x - 4y = 4$

o $-2x - y = 3$

p $-2x - 3y = -9$

Hint:

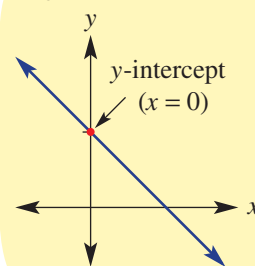

5B

Example 6 Finding the x -intercept

Find the x -intercept for these linear relations.

a $y = 2x + 4$

b $3x - 2y = 12$

Solution**Explanation**

a $y = 2x + 4$

x -intercept (let $y = 0$):

$$0 = 2x + 4$$

$$-4 = 2x$$

$$-2 = x$$

$$x = -2$$

the x -intercept is -2

Substitute $y = 0$ into the rule to find the x -coordinate of the x -intercept.

Solve the equation by subtracting 4 from both sides. Then divide both sides by 2.

Using coordinates the x -intercept is at $(-2, 0)$.

b $3x - 2y = 12$

x -intercept (let $y = 0$):

$$3x - 2 \times (0) = 12$$

$$3x = 12$$

$$x = 4$$

the x -intercept is 4

Substitute $y = 0$ to find the x -intercept.

$2 \times 0 = 0$ and then solve the remaining equation for x .

Using coordinates the x -intercept is at $(4, 0)$.

Now you try

Find the x -intercept for these linear relations.

a $y = 3x - 6$

b $5x + 4y = -15$

6 Find the x -intercept for these linear relations.

a $y = x + 6$

b $y = x - 4$

c $y = 2x - 8$

d $y = 3x + 6$

e $y = -2x - 8$

f $y = -4x + 12$

g $x + 2y = 7$

h $2x - y = 4$

i $3x + 4y = 12$

j $4x - 6y = 24$

k $-2x + 3y = -2$

l $-5x - 7y = 15$

Problem-solving and reasoning

7, 8

7-10

7 Find the x -intercept and y -intercept for these linear relations involving fractions.

Leave coordinates in fraction form.

a $y = 2x - 1$

b $y = \frac{1}{2}x - 2$

c $y = -\frac{1}{3}x + 4$

d $3x + 2y = 7$

Hint: Recall that another way of writing $\frac{1}{2}x$ is $\frac{x}{2}$.



8 The height, h , in metres, of a lift above ground after t seconds is given by $h = 100 - 5t$.

a What height does the lift start at (at $t = 0$)?

b How long does it take for the lift to reach the ground ($h = 0$)?

- 9 Water is being drained from a fish tank. The amount of water in the tank, V litres, after t minutes is given by the rule $V = 80 - 4t$.
- How long will it be until the tank is empty ($V = 0$)?
 - How much water was in the tank to begin with ($t = 0$)?



- 10 The line $y = 3x$ has both its x -intercept and y -intercept with coordinates $(0, 0)$. Can you explain how this is the case, and what it means for the graph of $y = 3x$?



Making money

—

11

- 11 Ana makes badges to sell at the market. The rule for the amount of money, A dollars, she makes from the sale of b badges is given by $A = 2b - 60$.
- What is the value of A if she sells no badges ($b = 0$)?
 - Can you explain your answer to part **a**?
 - How many badges must she sell to cover her initial costs ($A = 0$)?
 - What happens when she sells more badges than in your answer to part **c**?
 - Use the information from your answers above to draw a graph for the rule on the axes shown. The A -axis is the y -axis and the b -axis is the x -axis.

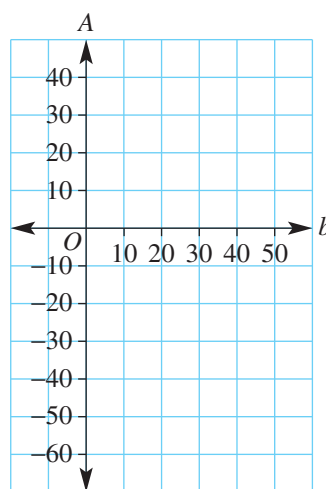

5C Graphing straight lines using intercepts

Learning intentions

- To understand that only two points are required to sketch a straight line graph
- To know that the x -intercept and the y -intercept are two key points often used to sketch a straight line graph
- To be able to sketch a linear relation by finding the x - and y -intercepts

Key vocabulary: x -intercept, y -intercept, linear relation

When linear equations are graphed, all the points lie in a straight line. This means that it is possible to graph a straight line using only two points. Two critical points that help draw these graphs are the x -intercept and y -intercept. Once these two points are located, they can be joined to form a straight line illustrating all the other points that lie on the line.



Straight lines are frequently used in business to illustrate the relationship between variables.

Lesson starter: Two key points

Consider the relation $y = 2x - 2$.

- Write a set of steps for another student, explaining to them how to find the y -intercept using the rule.
- Write another set of steps, this time explaining how to find the x -intercept using the rule.
- Now that you have these two points, describe how you would use them to sketch the graph of $y = 2x - 2$ on the axes shown, without drawing up a table of values.

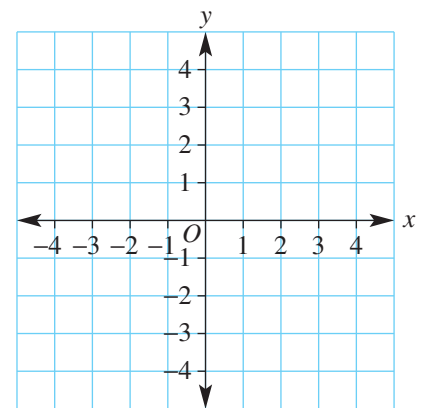

Key ideas

- A straight line can be drawn using only two points.
- Two key points we can use to graph a straight line are the x -intercept and y -intercept.
- To graph a linear relation using intercepts:
 - find the y -intercept by substituting $x = 0$ into the rule
 - find the x -intercept by substituting $y = 0$ into the rule
 - plot the two points on the axes
 - draw a straight line passing through the two intercepts.

For example: $3x + 5y = 15$

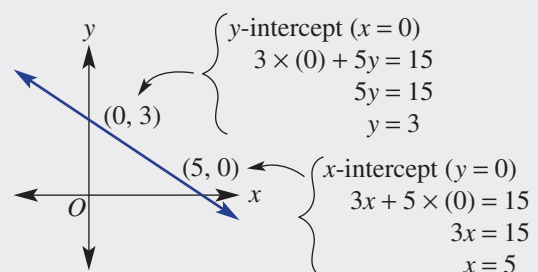

Exercise 5C

Understanding

1–4

4

- Insert the missing number.
 - A minimum of ____ points are required to sketch a straight line.
 - To find the y -intercept, substitute $x =$ ____.
 - If $(2, a)$ is an x -intercept, the value of a is ____.
- For these equations, find the y -intercept by letting $x = 0$.
 - $2x + 3y = 9$
 - $y = 2x - 4$
- For these equations, find the x -intercept by letting $y = 0$.
 - $2x - y = -4$
 - $y = 3x - 6$
- Plot each of the following pairs of points on a set of axes and join the points to form a straight line.
 - $(3, 0)$ and $(0, -2)$
 - $(0, 4)$ and $(2, 0)$
 - $(-3, 0)$ and $(0, 6)$
 - $(1, 0)$ and $(0, 3)$

Hint: $(3, 0)$ is on the x -axis as it is 3 to the right of the origin and 0 up or down.



Fluency

5–6(1/2)

5–6(1/2)



Example 7 Sketching linear relations of the form $ax + by = d$ using intercepts

Sketch the graph of $2x + 3y = 6$, showing the x - and y -intercepts.

Solution

Explanation

$$2x + 3y = 6$$

y -intercept (let $x = 0$):

$$2 \times (0) + 3y = 6$$

$$3y = 6$$

$$y = 2$$

\therefore the y -intercept is 2

x -intercept (let $y = 0$):

$$2x + 3 \times (0) = 6$$

$$2x = 6$$

$$x = 3$$

\therefore the x -intercept is 3

Only two points are required to generate a straight line.

For the y -intercept, substitute $x = 0$ into the rule and solve for y by dividing each side by 3.

State the y -intercept. Plot the point $(0, 2)$.

To find the x -intercept, substitute $y = 0$ into the rule and solve for x .

State the x -intercept. Plot the point $(3, 0)$.

Mark and label the intercepts on the axes and sketch the graph by joining the two intercepts. Continue the line past these points.

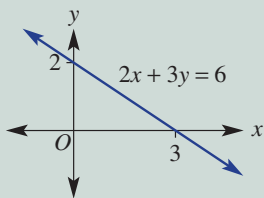

Now you try

Sketch the graph of $3x + 4y = 12$, showing the x - and y -intercepts.

5C

- 5 Sketch the graph of the following relations, by finding the x - and y -intercepts.

a $x + y = 2$

b $x + y = 5$

c $x - y = 3$

d $x - y = -2$

e $2x + y = 4$

f $3x - y = 9$

g $4x - 2y = 8$

h $3x + 2y = 6$

i $3x - 2y = 6$

j $y - 3x = 12$

k $-5y + 2x = -10$

l $-x + 7y = 21$

Hint: For the x -intercept, let $y = 0$.
For the y -intercept, let $x = 0$.



Example 8 Sketching linear relations of the form $y = mx + c$ using intercepts

Sketch the graph of $y = 2x - 6$, showing the x - and y -intercepts.

Solution

$$y = 2x - 6$$

y -intercept (let $x = 0$):

$$y = 2 \times (0) - 6$$

$$y = -6$$

\therefore the y -intercept is -6

x -intercept (let $y = 0$):

$$0 = 2x - 6$$

$$6 = 2x$$

$$x = 3$$

\therefore the x -intercept is 3

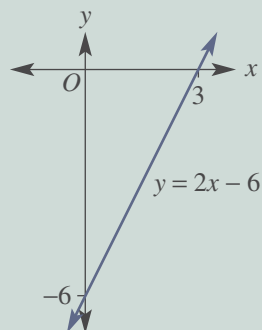

Explanation

Substitute $x = 0$ for the y -intercept.

Simplify to find the y -coordinate.

Plot the point $(0, -6)$.

Substitute $y = 0$ for the x -intercept. Solve the remaining equation for x by adding 6 to both sides. Then divide both sides by 2 .

Plot the point $(3, 0)$.

Mark in the two intercepts and join to sketch the graph.

Now you try

Sketch the graph of $y = 2x + 4$, showing the x - and y -intercepts.

- 6 Sketch the graph of the following relations, showing the x - and y -intercepts.

a $y = 3x + 3$

b $y = 2x + 2$

c $y = x - 5$

d $y = -x - 6$

e $y = -2x - 2$

f $y = -3x - 6$

g $y = -2x + 4$

h $y = 2x - 3$

i $y = -x + 1$

j $y = -2x + 1$

Hint: To solve:

$$3x + 3 = 0$$

$$3x = -3 \text{ (subtract 3)}$$

$$x = -1 \text{ (divide by 3)}$$



Problem-solving and reasoning

7, 8

7–9

- 7 The distance, d metres, of a remote controlled car from an observation point after t seconds is given by the rule $d = 8 - 2t$.
- Find the distance from the observation point initially (at $t = 0$).
 - Find after what time, t , the distance, d , is equal to 0 (substitute $d = 0$).
 - Sketch a graph of d versus t between the points from part **a** (the d -intercept) and part **b** (the t -intercept).

Hint: The axes will have d on the vertical axis and t on the horizontal axis.



- 8 Use your algebra and fraction skills to help sketch graphs for these relations by finding x - and y -intercepts.

a $\frac{x}{2} + \frac{y}{3} = 1$

b $y = \frac{8-x}{4}$

c $\frac{y}{2} = \frac{2-4x}{8}$

Hint: Recall: $\frac{0}{2} = 0$



- 9 Give reasons why the x -intercept on these graphs has the exact coordinates $(1.5, 0)$.

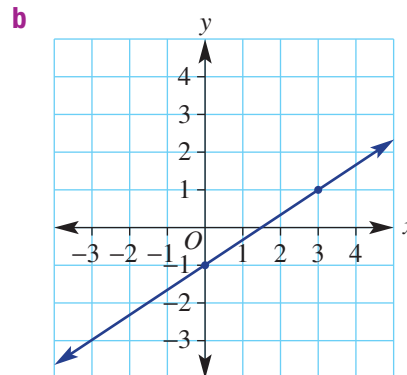
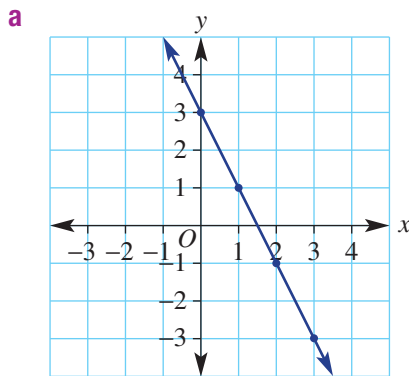

Points to rules

—

10

- 10 Write down the rule for the graph with these axes intercepts. Write the rule in the form $ax + by = d$.
- $(0, 4)$ and $(4, 0)$
 - $(0, 2)$ and $(2, 0)$
 - $(0, -3)$ and $(3, 0)$
 - $(0, 1)$ and $(-1, 0)$



Using a calculator 5C: Sketching straight lines

This activity can be found in the More Resources section of the Interactive Textbook in the form of a printable PDF.

5D Lines with one intercept

Learning intentions

- To understand that vertical and horizontal lines have the same x -coordinate or the same y -coordinate, respectively
- To know the equation form of vertical and horizontal lines
- To be able to graph vertical and horizontal lines and determine their rule from a graph
- To know that lines of the form $y = mx$ pass through the origin
- To be able to sketch lines that pass through the origin

Key vocabulary: origin, vertical, horizontal, parallel, x -intercept, y -intercept

Vertical and horizontal lines are special types of lines. You often see them in houses and construction.

When plotting a graph, a vertical line runs parallel to the y -axis. Since parallel lines never touch, the line will never cross the y -axis, and has only one intercept, on the x -axis.

Horizontal lines run parallel to the x -axis and they have only one intercept, on the y -axis.

Lines that pass through the origin $(0, 0)$ also have only one intercept, as the x - and y -intercepts are the same point.

→ Lesson starter: What rule satisfies all points?

Here is one vertical (red) and one horizontal (blue) line.

- For the vertical line shown, write down the coordinates of all the points shown as dots.
- What is always true for each coordinate pair?
- Can you think of a simple equation that describes every point on the line?
- For the horizontal line shown, write down the coordinates of all the points shown as dots.
- What is always true for each coordinate pair?
- Can you think of a simple equation that describes every point on the line?

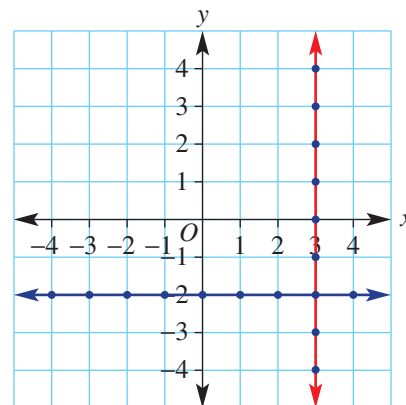

Key ideas

■ Vertical line: $x = b$

- **Parallel** to the y -axis, the x -coordinate is the same for every point on the line.
- The equation is of the form $x = b$, where b is a constant (fixed number).
- The x -intercept coordinates are $(b, 0)$.
- There is no y -intercept.

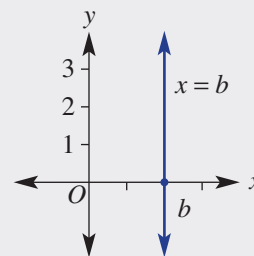

■ Horizontal line: $y = c$

- Parallel to the x -axis, the y -coordinate is the same for every point on the line.
- The equation is of the form $y = c$, where c is a constant (fixed number).
- The y -intercept coordinates are $(0, c)$.
- There is no x -intercept.

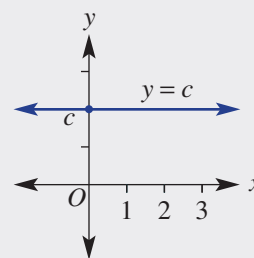

- Lines through the origin $(0, 0)$: $y = mx$
 - The y -intercept is 0.
 - The x -intercept is 0.
 - Since the x - and y -intercepts give only one point, a second point is required. Substitute any x value into the rule to give a second point. Use $x = 1$ for ease of calculation.

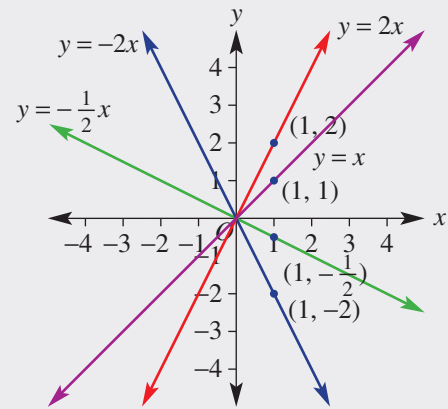

Exercise 5D

Understanding

1–4

2, 4

- 1 Classify the following lines as either *horizontal* or *vertical*.

- a** $y = 3$ **b** $y = -1$ **c** $x = 2$
d $y = 0$ **e** $x = -5$ **f** $x = 0$

Hint: Will they be parallel to the x -axis or y -axis?



- 2 Select the features from the list (i–v) that apply to:

- a** horizontal lines **b** vertical lines

- i** parallel to the y -axis
ii has a y -intercept
iii has an x -intercept
iv parallel to the x -axis
v always pass through the origin

Hint: Draw a horizontal and vertical line to help.



- 3 **a** What is the x -coordinate of each point on these graphs?

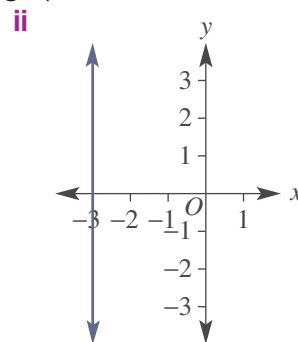
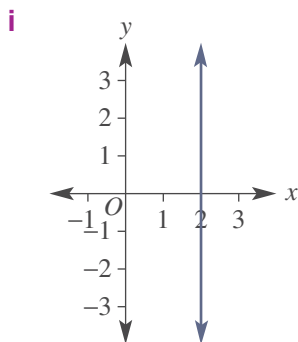

- b** What is the y -coordinate of each point on these graphs?

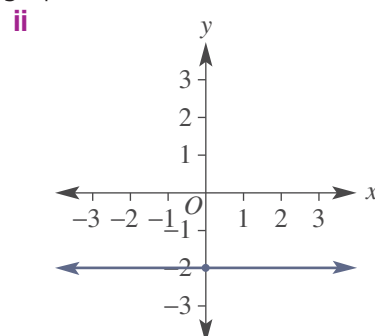
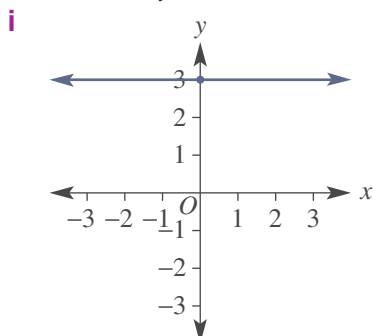

5D

4 List which of the following rules will have graphs that pass through $(0, 0)$.

a $y = 4$

b $y = 2x$

c $y = 3x + 2$

d $x = 2$

e $y = -x$

f $y = \frac{1}{2}x$

Hint: Equations of the form $y = mx$ pass through the origin.



Fluency

5-7(1/2), 8

5-8(1/2)



Example 9 Graphing vertical and horizontal lines

Sketch the graph of the following vertical and horizontal lines.

a $y = 3$

b $x = -4$

c $y = 0$

Solution

Explanation

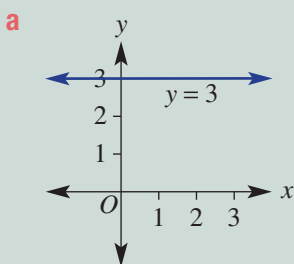

Each point on the line has a y -coordinate of 3, so the y -intercept is 3.

Sketch a horizontal line through all points where $y = 3$.

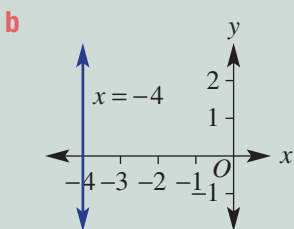

Each point on the line has an x -coordinate of -4 , so the x -intercept is -4 .

Sketch a vertical line through all points where $x = -4$.

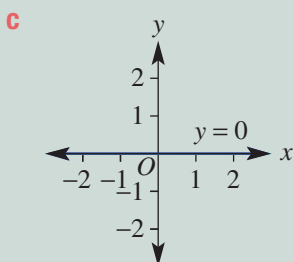

Each point on the line has a y -coordinate of 0.

Sketch a horizontal line through all points where $y = 0$; this line is the x -axis.

Now you try

Sketch the graph of the following vertical and horizontal lines.

a $y = -1$

b $x = 3$

c $x = 0$

5 Sketch the graph of the following vertical and horizontal lines.

a $x = 2$

b $x = 5$

c $y = 4$

d $y = 1$

e $x = -3$

f $x = -2$

g $y = -1$

h $y = -3$

Hint: Do they have an x -intercept or a y -intercept?





Example 10 Sketching lines that pass through the origin

Sketch the graph of $y = 3x$.

Solution

$$y = 3x$$

The x - and y -intercept are both 0.

Another point (let $x = 1$):

$$y = 3 \times (1)$$

$$y = 3$$

Another point is at $(1, 3)$.

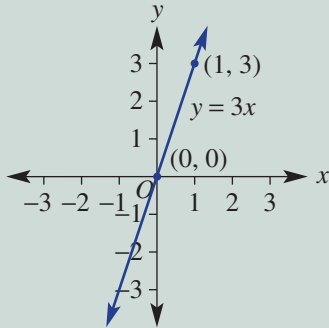

Explanation

The equation is of the form $y = mx$; i.e. when you substitute $x = 0$, $y = 3 \times 0 = 0$, giving 0 as both the x - and y -intercepts.

Two points are required to generate the straight line. Find another point by substituting $x = 1$.

Any other x value could be used but the calculation is simplest for $x = 1$.

Plot and label both points and sketch the graph by joining the points in a straight line.

Now you try

Sketch the graph of $y = 4x$.

6 Sketch the graph of the following linear relations, which pass through the origin.

a $y = 2x$

b $y = 5x$

c $y = 6x$

d $y = x$

e $y = -4x$

f $y = -3x$

g $y = -2x$

h $y = -x$

i $y = \frac{1}{2}x$

7 Sketch the graphs of these special lines all on the same set of axes and label with their equations.

a $x = -2$

b $y = -3$

c $y = 2$

d $x = 4$

e $y = 4x$

f $y = -\frac{1}{2}x$

g $y = -1.5x$

h $x = 0.5$

i $x = 0$

j $y = 0$

k $y = 2x$

l $y = 1.5x$

Hint: Substitute $x = 1$ to obtain a second point.



Hint: There are vertical lines, horizontal lines and lines through the origin.



Example 11 Finding the equation of horizontal and vertical lines

Give the equation of the following vertical and horizontal lines.

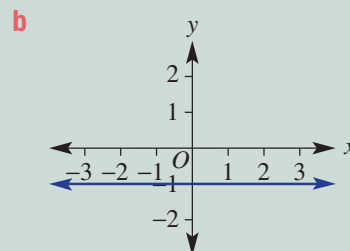
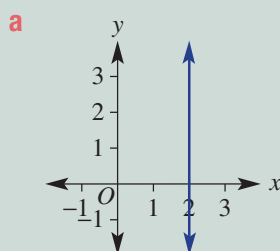

Continued on next page

5D

Solution

a $x = 2$

Explanation

Line is vertical, with x -coordinate always 2.

b $y = -1$

Line is horizontal, with y -coordinate always -1 .

Now you try

Give the equation of the following vertical and horizontal lines.

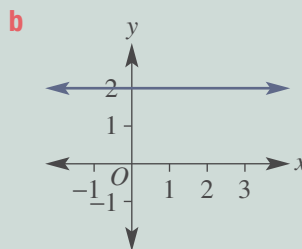
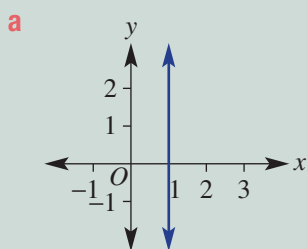

8 Give the equation of the following vertical and horizontal lines.

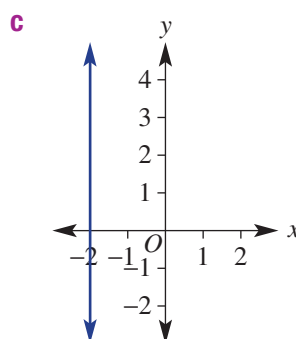
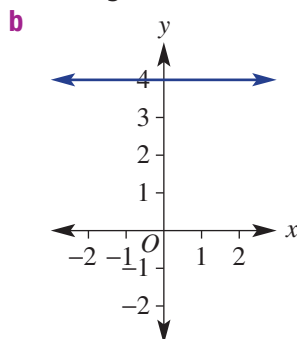
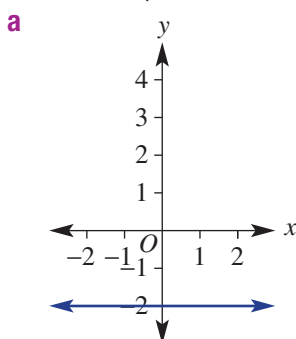

Hint: A horizontal line has the form $y = c$.
A vertical line has the form $x = b$.

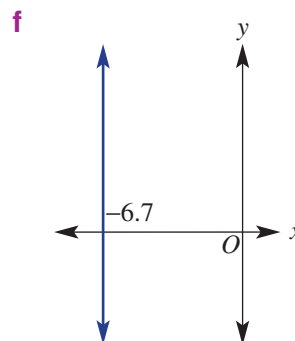
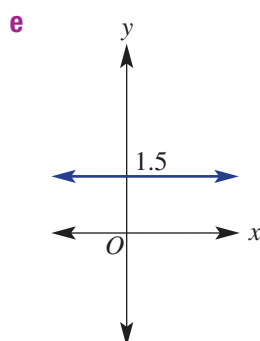
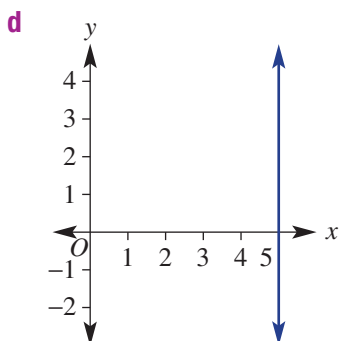

Problem-solving and reasoning

9, 10

9–11

9 Find the equation of the straight line that is:

- a parallel to the x -axis and passes through the point $(1, 3)$
- b parallel to the y -axis and passes through the point $(5, 4)$
- c parallel to the y -axis and passes through the point $(-2, 4)$
- d parallel to the x -axis and passes through the point $(0, 0)$

Hint: First decide whether the line is horizontal or vertical, then use the point.



- 10 If, in a picture, the surface of the sea is represented by the x -axis, state the equation of the following paths.
- A plane flies horizontally at 250 m above sea level. One unit is 1 metre.
 - A submarine travels horizontally 45 m below sea level. One unit is 1 metre.



- 11 The rules of the following graphs are of the form $y = mx$. Use the points marked with a dot to find m and hence state the equation.

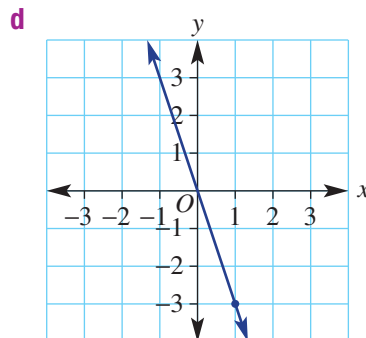
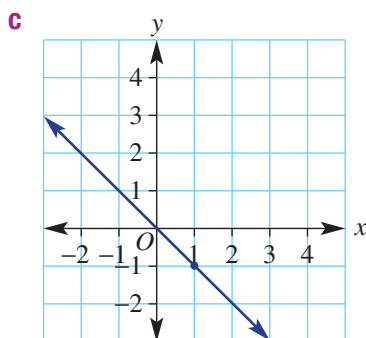
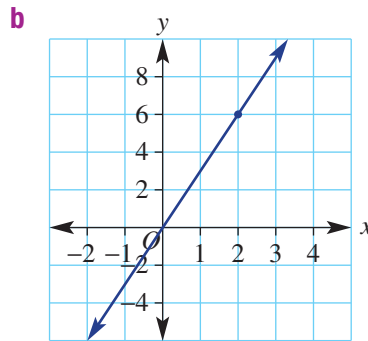
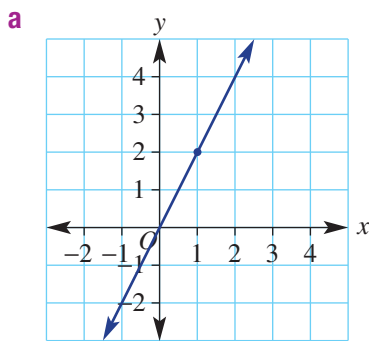

Hint: In a rule such as $y = 3x$, when $x = 1$, $y = 3 \times 1 = 3$.



Rectangular areas

12, 13

The four lines $x = 1$, $x = 3$, $y = 2$ and $y = 5$ drawn on the one set of axes form a rectangle, as shown (shaded). The area of this rectangle is length \times width = $3 \times 2 = 6$ square units.

- 12 Find the area of the rectangle contained within the following four lines.
- $x = 1, x = -2, y = -3, y = 2$
 - $x = 0, x = 17, y = -5, y = -1$
- 13 The lines $x = -1, x = 3$ and $y = -2$ form three sides of a rectangle. Find the possible equation of the fourth line if:
- the area of the rectangle is:
 - 12 square units
 - 8 square units
 - 22 square units
 - the perimeter of the rectangle is:
 - 14 units
 - 26 units
 - 31 units

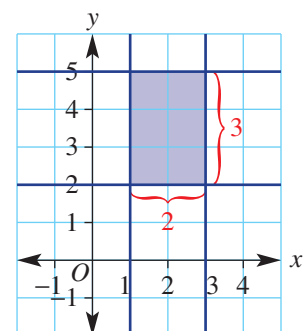

5E Gradient

Learning intentions

- To understand what is meant by the gradient of a line
- To know that the gradient of a straight line is constant
- To know that the gradient of a line can be positive, negative, zero or undefined
- To be able to find the gradient of a line from a graph or between two given points

Key vocabulary: gradient, rise, run

The gradient of a line is a measure of its slope. It is a number that describes the steepness of a line. It is calculated by considering how far a line rises or falls between two points within a given horizontal distance. The horizontal distance between two points is called the *run*. The vertical distance is called the *rise*.

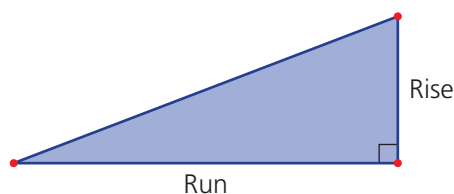

Lesson starter: Which line is the steepest?

The three lines here connect the points A, B, C, D, E, F, G and H .

- Calculate the rise and run (working from left to right) and also the fraction $\frac{\text{rise}}{\text{run}}$ for these segments.
 - AB
 - BC
 - BD
 - EF
 - GH
- What do you notice about the fractions $\left(\frac{\text{rise}}{\text{run}}\right)$ for parts **i**, **ii** and **iii**?
- How does the $\frac{\text{rise}}{\text{run}}$ for EF compare with the $\frac{\text{rise}}{\text{run}}$ for parts **i**, **ii** and **iii**? Which of the two lines is the steepest?
- Your $\frac{\text{rise}}{\text{run}}$ for GH should be negative. Why is this the case?
- Discuss whether or not GH is steeper than AD .

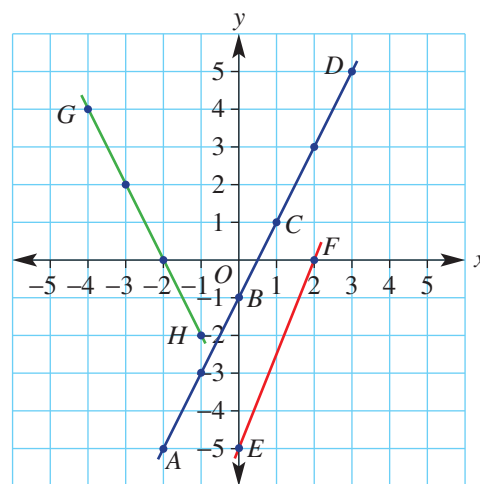

Use computer software (dynamic geometry) to produce a set of axes and grid.

- Construct a line segment with endpoints on the grid. Show the coordinates of the endpoints.
- Calculate the rise (vertical distance between the endpoints) and the run (horizontal distance between the endpoints).
- Calculate the gradient as the *rise* divided by the *run*.
- Now drag the endpoints and explore the effect on the gradient.
- Can you drag the endpoints but retain the same gradient value? Explain why this is possible.
- Can you drag the endpoints so that the gradient is zero or undefined? Describe how this can be achieved.

Key ideas

- The **gradient** of a line is a measure of its steepness or slope.
- The gradient of a line can be found using gradient $(m) = \frac{\text{rise}}{\text{run}}$.
 - We work from left to right, so the run is always positive.

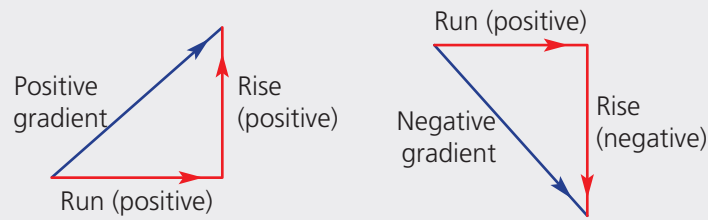

- The gradient can be positive, negative, zero or undefined.
 - The gradient is positive if the graph increases from left to right.
 - The gradient is negative if the graph decreases from left to right.
 - The gradient is zero if the line is horizontal.
 - The gradient is undefined if the line is vertical.

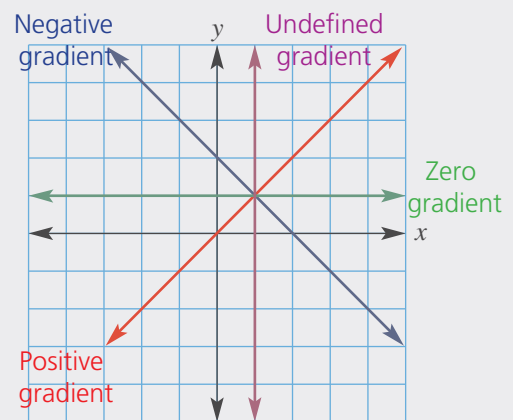

Exercise 5E

Understanding

1, 2

2

- 1 For these lines, calculate the value for: **i** run **ii** rise

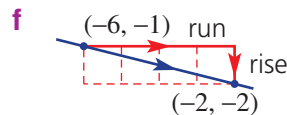
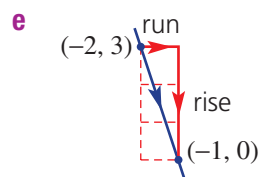
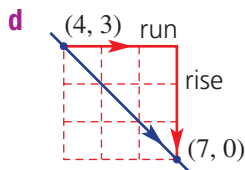
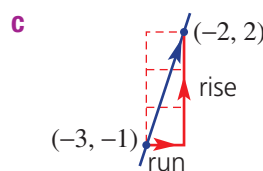
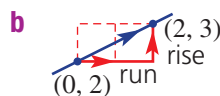
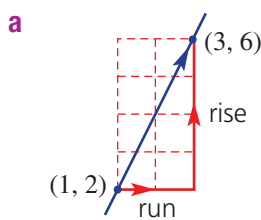

Hint: Remember that the rise is negative if the line slopes downward from left to right.



- 2 Use the words 'positive', 'negative', 'zero' or 'undefined' to complete each sentence.
- The gradient of a horizontal line is _____.
 - The gradient of the line joining $(0, 3)$ with $(5, 0)$ is _____.
 - The gradient of the line joining $(-6, 0)$ with $(1, 1)$ is _____.
 - The gradient of a vertical line is _____.

Fluency

3(1/2), 5(1/2)

3(1/2), 4, 5(1/2)



Example 12 Finding the gradient of a line

For each graph, state whether the gradient is positive, negative, zero or undefined, then find the gradient, where possible.

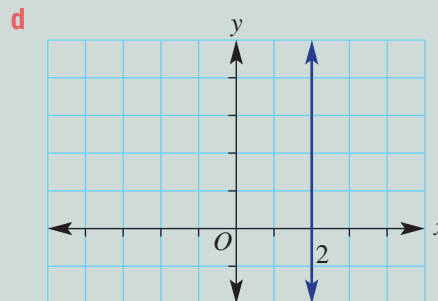
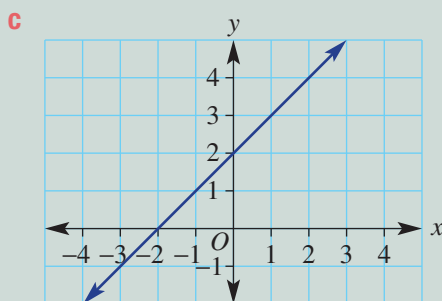
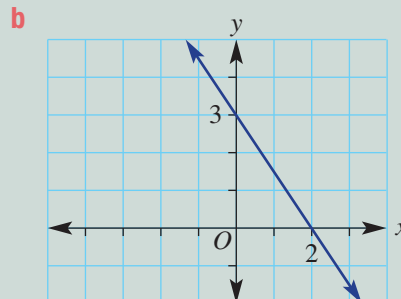
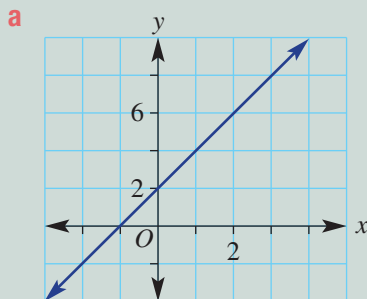

Solution

a The gradient is positive.

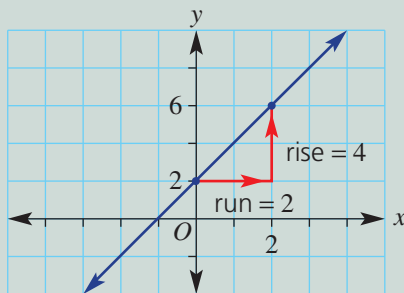

$$\begin{aligned} \text{Gradient} &= \frac{\text{rise}}{\text{run}} \\ &= \frac{4}{2} \\ &= 2 \end{aligned}$$

By inspection, the gradient will be positive since the graph increases from left to right.

Select any two points and create a right-angled triangle between them to determine the rise and run. Substitute rise = 4 and run = 2, and simplify.

b The gradient is negative.

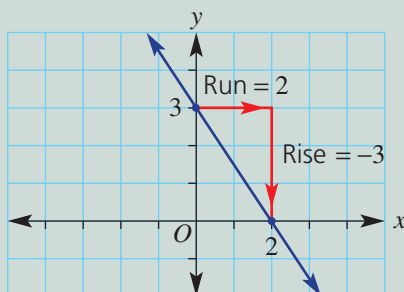

$$\begin{aligned} \text{Gradient} &= \frac{\text{rise}}{\text{run}} \\ &= \frac{-3}{2} \\ &= -\frac{3}{2} \end{aligned}$$

By inspection, the gradient will be negative since y values decrease from left to right.

Create a right-angled triangle between two points. Rise = -3 since it 'falls' 3 units, and run = 2.

Explanation

c The gradient is positive.

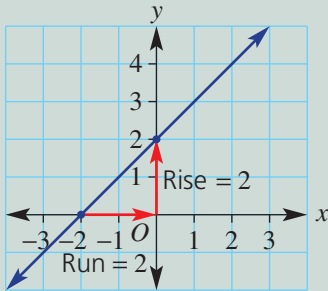

$$\begin{aligned}\text{Gradient} &= \frac{\text{rise}}{\text{run}} \\ &= \frac{2}{2} \\ &= 1\end{aligned}$$

A rising graph indicates a positive gradient.

For this triangle, rise = 2. The run is from left to right, from -2 to 0 , so the run is $+2$.

d The gradient is undefined.

The line is vertical.

Now you try

For each graph, state whether the gradient is positive, negative, zero or undefined, then find the gradient, where possible.

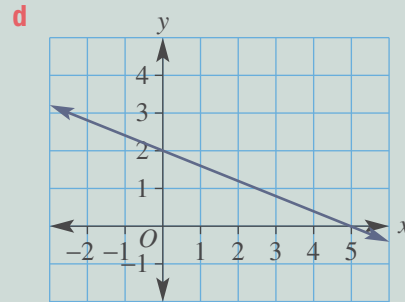
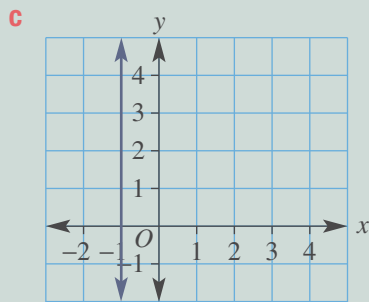
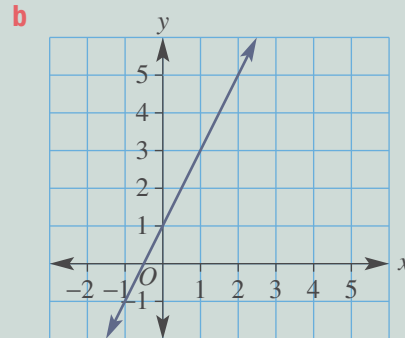
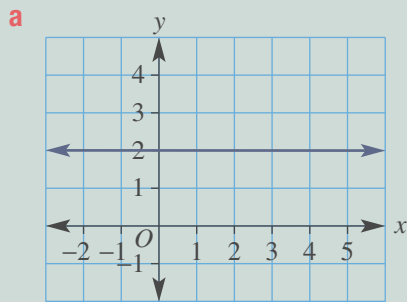

3 For each graph state whether the gradient is positive, negative, zero or undefined, then find the gradient where possible.

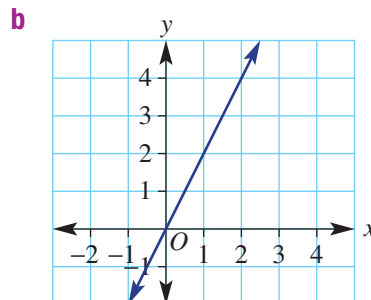
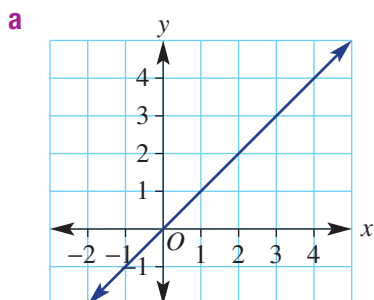

Hint: Create a right-angled triangle to find the rise and the run.

$$\text{Gradient} = \frac{\text{rise}}{\text{run}}$$



5E

c

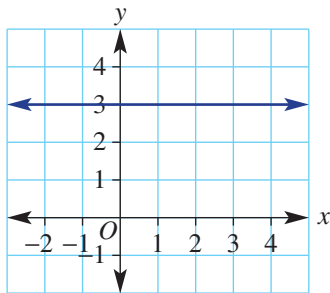

d

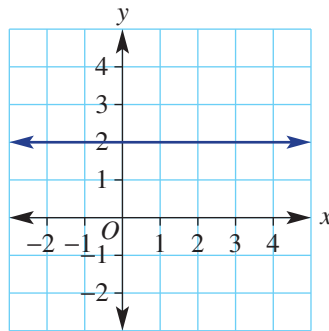

e

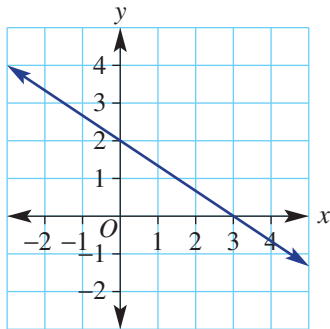

f

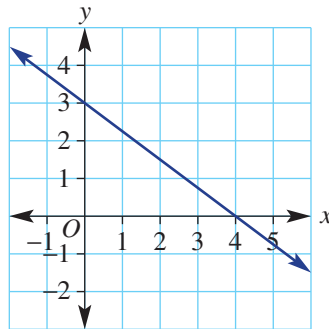

g

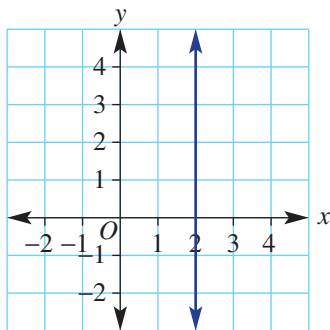

h

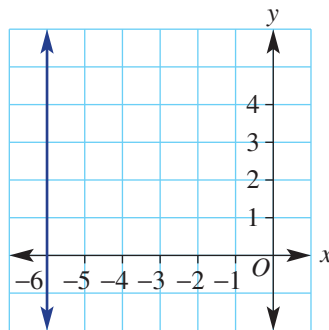

i

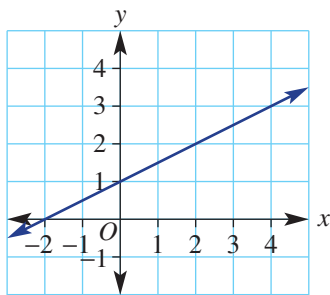

j

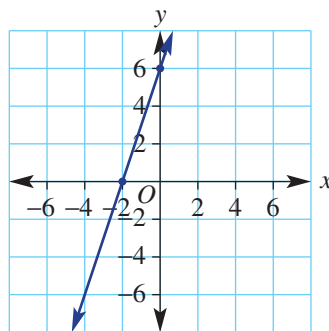

k

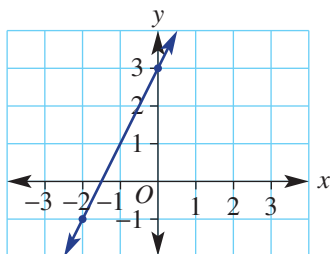

l

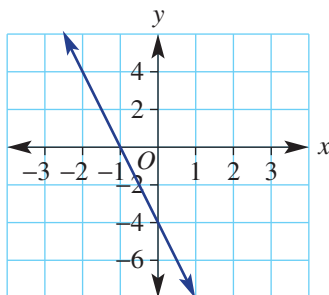

Hint: In part k, from -1 to 3 is a rise of 4 .



- 4 Find the gradient of each line A – F on this graph and grid.

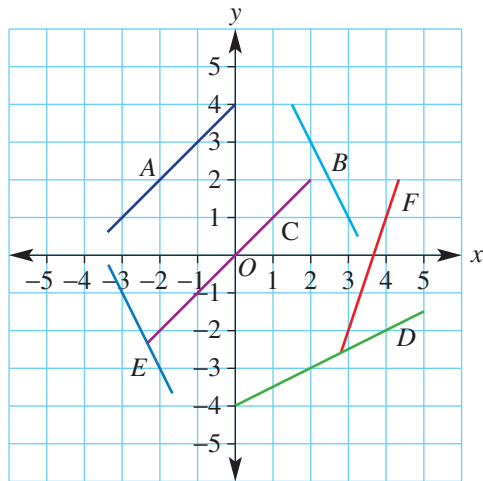

Hint: Pick two known points on each line to find the gradient between them.



Example 13 Finding the gradient between two points

Find the gradient (m) of the line joining the given points.

a $A(3, 4)$ and $B(5, 6)$

b $A(-3, 6)$ and $B(1, -3)$

Solution

a

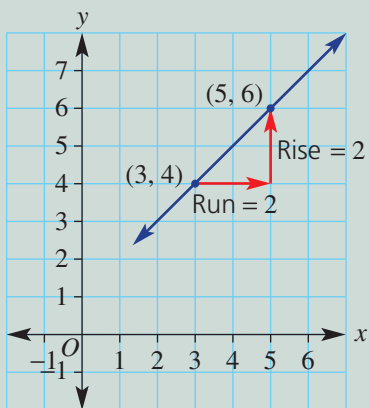

$$\begin{aligned} m &= \frac{\text{rise}}{\text{run}} \\ &= \frac{2}{2} \\ &= 1 \end{aligned}$$

Explanation

Plot the two points on a set of axes and construct a right-angled triangle between them.

Observe from the graph that the gradient will be positive. Calculate the gradient by finding the rise and run.

b

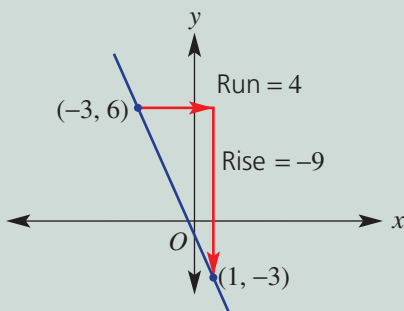

$$\begin{aligned} m &= \frac{\text{rise}}{\text{run}} \\ &= \frac{-9}{4} \text{ or } -\frac{9}{4} \text{ or } -2.25 \end{aligned}$$

Plot points A and B and join in a line. Observe that the gradient will be negative.

From left to right, -3 to 1 , run = 4 .

Rise from 6 to -3 is a 'fall' of 9 units, so rise = -9 .

Now you try

Find the gradient (m) of the line joining the given points.

a $A(2, 3)$ and $B(4, 7)$

b $A(-2, 2)$ and $B(3, -6)$

5E

- 5 Find the gradient of the lines joining the following pairs of points.
- | | | | |
|---|----------------------------|---|----------------------------|
| a | $A(2, 3)$ and $B(3, 5)$ | b | $C(0, 8)$ and $D(2, 6)$ |
| c | $E(0, 4)$ and $F(2, 0)$ | d | $G(2, 1)$ and $H(5, 4)$ |
| e | $A(1, 5)$ and $B(2, 7)$ | f | $C(-2, 4)$ and $D(1, -2)$ |
| g | $E(-3, 4)$ and $F(2, -1)$ | h | $G(-1, 5)$ and $H(1, 6)$ |
| i | $A(-4, -2)$ and $B(-2, 1)$ | j | $C(1, 1)$ and $D(3, -4)$ |
| k | $E(3, 2)$ and $F(0, 1)$ | l | $G(-1, 1)$ and $H(-3, -4)$ |

Hint: Plot the points to help visualise the rise and run.



Problem-solving and reasoning

6, 7

6, 8, 9

- 6 Find the gradient, using $\frac{\text{rise}}{\text{run}}$, corresponding to the following slopes.
- A road falls 10 m for every 200 horizontal metres.
 - A cliff rises 35 metres for every 2 metres horizontally.
 - A plane descends 2 km for every 10 horizontal kilometres.
 - A submarine ascends 150 m for every 20 horizontal metres.
- 7 A firecracker ascends with a gradient of 2. How far, horizontally, has the cracker travelled after rising 80 m?
- 8 Sally runs up a sand dune that has a gradient of $\frac{1}{3}$. How far, horizontally, has Sally moved after rising 30 m?

Hint: The horizontal distance is the run.



- 9 Find the missing number.
- The gradient joining the points $(0, 2)$ and $(1, ?)$ is 4.
 - The gradient joining the points $(?, 5)$ and $(3, 9)$ is 2.
 - The gradient joining the points $(-3, 4)$ and $(?, 1)$ is -1 .
 - The gradient joining the points $(-4, ?)$ and $(-2, -12)$ is -4 .

Hint: A gradient of $4 = \frac{4}{1}$: a rise of 4 units for every 1 unit to the right.



★ Where does it hit?

—

10

- 10 The line here has gradient $-\frac{2}{3}$, which means that it falls 2 units for every 3 units across. The y -intercept is $(0, 3)$.
- Use the gradient to find the y -coordinate on the line where:
 - $x = 6$
 - $x = 9$
 - What will be the coordinates of the x -intercept?
 - What would be the x -intercept if the gradient was changed to:
 - $-\frac{1}{2}$?
 - -2 ?
 - $-\frac{5}{4}$?

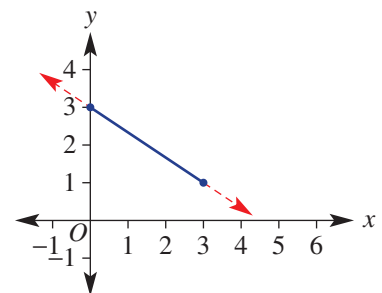

5F Gradient and direct proportion

Learning intentions

- To understand that gradient represents the rate of change of one variable with respect to another
- To understand what it means for two variables to be directly proportional
- To be able to identify the form of the linear rule for two variables in direct proportion
- To be able to form and work with rules in direct proportion

Key vocabulary: rate, variable, gradient, directly proportional

We have seen that the gradient of a line is the increase or decrease (rise) of the y values compared to the change (run) in the x values.

Gradient can also be considered as a rate. It is the rate of change of y with respect to x . Speeds such as 60 km/h or 10 m/s are a common form of rates. They give the change in distance with respect to time; e.g. 60 km each hour or 10 m each second.

The connection between gradient, rate problems and direct proportion can be shown through the use of linear rules and graphs. If two variables are directly related, then the rate of change of one variable with respect to the other is constant. This means that the rule linking the two variables is linear and can be represented as a straight line graph passing through the origin.

The amount of water squirting from a hose, for example, is directly proportional to the time since it was turned on. The gradient of the graph of *water volume* versus *time* will determine the rate at which water is squirting from the hose.

→ Lesson starter: Average speed

Over 5 hours, Sandy travels 400 km in a car.

- What is Sandy's average speed for the trip?
- Draw a graph of distance versus time for the journey, assuming a constant speed.
- Where does your graph intersect the axes and why?
- Find the gradient of your graph. What do you notice?
- Find a rule linking distance (d) and time (t).

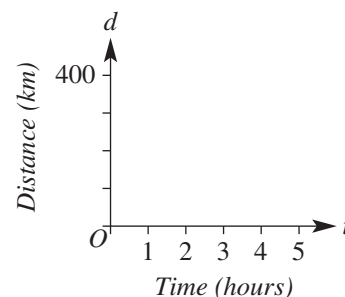

Key ideas

- A rate is the change in one variable compared with another. For example, 60 km/h (60 km per hour) is a rate. It states a 60 km change in distance for each hour in time that passes.
 - A rate in simplest form is written as a change in one variable per one unit of another variable. For example, we simplify 40 km in 2 hours to 20 km per hour or 20 km/h.
- If two variables are **directly proportional**:
 - the rate of change of one variable with respect to the other is constant
 - the graph is a straight line passing through the origin
 - the rule is of the form $y = mx$
 - the gradient (m) of the graph equals the rate of change of the y variable with respect to the x variable.

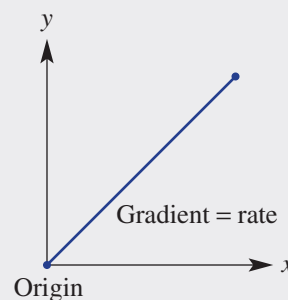

5F

Exercise 5F

Understanding

1–3

3

- Write 'Yes' or 'No' to state which of the following are rates.
 - \$120
 - 12 cm/s
 - 150 mL/min
 - 80 km
- Write these rates in simplest form.
 - 120 km in 2 hours
 - 180 m in 20 seconds
 - 400 L in 80 min
 - \$30 for 20 litres
 - \$900 in 30 hours
 - 15°C in 5 min
- This graph shows how far Caroline travels on her bike over 4 hours.
 - State how far Caroline has travelled after:
 - 1 hour
 - 2 hours
 - 3 hours
 - Write down the speed of the bike in km/h (rate of change of distance over time).
 - Find the gradient of the graph.
 - What do you notice about your answers from parts **b** and **c**?

Hint: Simplest form is per 1 unit; e.g. 50 km in 1 hour, 50 km/h.

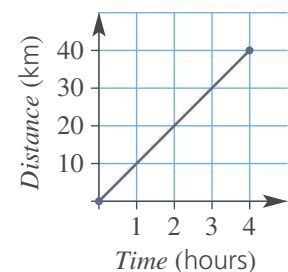

Fluency

4–6

4–7

 Example 14 Forming rules

Write a rule linking the variables A dollars and t hours if \$60 is earned in 5 hours of work.

Solution

$$60 \div 5 = 12$$

Rate is \$12/h.

$$A = 12 \times t$$

$$\therefore A = 12t$$

Explanation

$$\begin{array}{ccc} \div 5 & \begin{array}{l} \$60 \text{ in } 5 \text{ hours} \\ \$12 \text{ in } 1 \text{ hour} \end{array} & \div 5 \end{array}$$

The amount earned, A , is \$12 for each hour worked.
 t hours of work earns $12 \times t$ dollars.

Now you try

Write a rule linking the variables V litres and t seconds if a bucket contains 8 L of water from a hose after 4 seconds.

- Write down a rule linking the given variables.
 - I travel 720 km in 12 hours. Use d for distance and t for time.
 - A calf grows 12 cm in 6 months. Use g for growth height and t for time.
 - The cost of petrol is \$120 for 80 litres. Use C for cost and n for the number of litres.
 - The profit is \$10 000 for 500 tonnes. Use P for profit and t for the number of tonnes.

Hint: First write the rate in simplest form.





Example 15 Exploring direct proportion

Water is poured into an empty tank. It takes 3 hours to fill the tank with 6000 litres.

- a** What is the rate at which water is poured into the tank?
- b** Draw a graph of volume (V litres) vs time (t hours) using $0 \leq t \leq 3$.
- c** Find:
- i** the gradient of your graph
 - ii** the rule for V
- d** Use your rule to find:
- i** the volume after 1.5 hours
 - ii** the time to fill 5000 litres

Solution

a 6000 L in 3 hours = 2000 L/hour

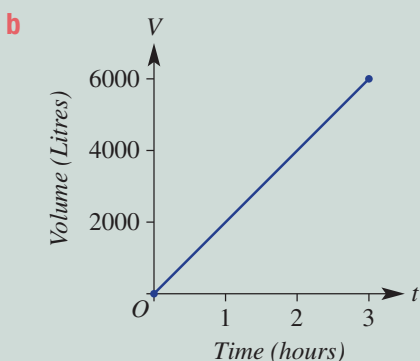

c i gradient = $\frac{6000}{3} = 2000$

ii $V = 2000t$

d i $V = 2000t$
 $= 2000 \times 1.5$
 $= 3000$
 \therefore 3000 L after 1.5 hours

ii $V = 2000t$
 $5000 = 2000t$
 $2.5 = t$

\therefore it takes $2\frac{1}{2}$ hours to fill 5000 L

Explanation

$$\begin{array}{c} \div 3 \quad \left(\begin{array}{l} 6000 \text{ L per 3 hours} \\ 2000 \text{ L per 1 hour} \end{array} \right) \quad \div 3 \end{array}$$

Draw axes with volume on the vertical axis and time on the horizontal axis, since volume depends on time.

Plot the two end points:
 $(0, 0)$ since the tank starts empty and $(3, 6000)$.
 Join these points with a straight line.

Using the end points, rise = 6000, run = 3.
 Note that the gradient is the same as the rate.

2000 L are filled for each hour.

Substitute $t = 1.5$ into your rule.

Substitute $V = 5000$ into the rule and solve for t by dividing each side by 2000.

Now you try

Water is poured into an empty inflatable pool. It takes 50 minutes to fill the pool with 2500 litres.

- a** What is the rate at which water is poured into the tank?
- b** Draw a graph of volume (V litres) vs time (t minutes) using $0 \leq t \leq 50$
- c** Find:
- i** the gradient of your graph
 - ii** the rule for V
- d** Use your rule to find:
- i** the volume after 20 minutes
 - ii** the time to fill 2000 litres

5F

- 5 A 300 litre fish tank takes 3 hours to fill using a hose.
- What is the rate at which water is poured into the tank?
 - Draw a graph of volume (V litres) vs time (t hours) using $0 \leq t \leq 3$.
 - Find:
 - the gradient of your graph
 - the rule for V
 - Use your rule to find:
 - the volume after 1.5 hours
 - the time to fill 200 litres

Hint: 300 litres in 3 hours; how many litres in 1 hour?



Hint: Place time on the horizontal axis.



- 6 A solar powered car travels 100 km in 4 hours.
- What is the rate of change of distance over time (i.e. speed)?
 - Draw a graph of distance (d km) vs time (t hours) using $0 \leq t \leq 4$.
 - Find:
 - the gradient of your graph
 - the rule for d
 - Use your rule to find:
 - the distance after 2.5 hours
 - the time to travel 40 km
- 7 Use the gradient to find the rate of change of distance over time (speed) for these graphs. Use the units given on each graph.

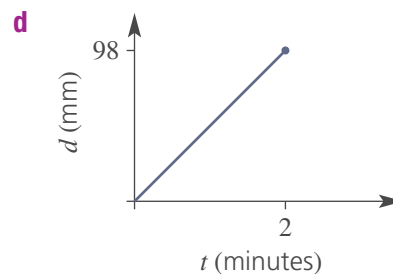
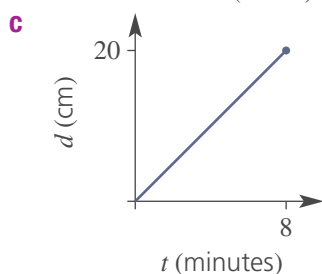
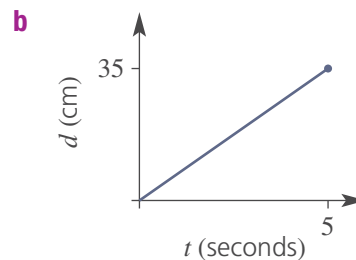
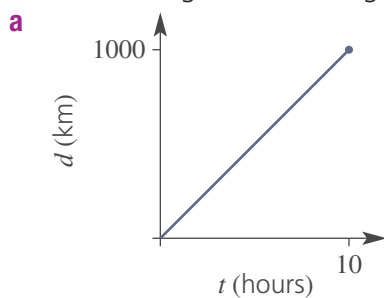

Problem-solving and reasoning

8, 9

9–11

- 8 Who is travelling the fastest?
- Mick runs 720 m in 2 minutes.
 - Sally rides 550 m in 1 minute.
 - Udhav jogs 2000 m in 5 minutes.
- 9 Which animal is travelling the slowest?
- A leopard runs 400 m in 30 seconds.
 - A jaguar runs 2700 m in 3 minutes.
 - A panther runs 60 km in $1\frac{1}{3}$ hours.



Hint: To compare rates, they will need to be in the same units.



- 10 A car's trip computer says that the fuel economy for a trip is 8.5 L per 100 km.
- How many litres would be used for 120 km?
 - How many litres would be used for 850 km?
 - How many kilometres could be travelled if the car's petrol tank capacity was 68 L?



Hint: Consider how many litres are used in 1 kilometre.



- 11 The area of a particular rectangle is given by $A = lw$. Its length is fixed at 12 cm but its width, w cm, can vary.
- Write a rule for the area of this rectangle.
 - Draw a graph of A against w for $0 \leq w \leq 4$.
 - Decide if the area of this rectangle is directly proportional to its width. Explain.

Hint: Equations of the form $y = mx$ show that y is directly proportional to x .



Rate challenge

—

12, 13

- 12 Hose A can fill a bucket in 2 minutes and hose B can fill the same bucket in 4 minutes.
- What fraction of a bucket does hose A fill in 1 minute?
 - What fraction of a bucket does hose B fill in 1 minute?
 - If both hoses were used at the same time, what fraction of a bucket could they fill in 1 minute?
 - If both hoses were used at the same time, how long would it take to fill the bucket?
- 13 Vonda can vacuum an office building in 2 hours and her husband Chris can vacuum the same office building in 3 hours. How long would it take to vacuum the office building if they both vacuumed at the same time?

5G Gradient–intercept form

Learning intentions

- To know that $y = mx + c$ is the gradient–intercept form of a straight line with m the gradient and c the y -intercept
- To know that any straight line equation can be expressed in gradient–intercept form
- To be able to rearrange a linear equation into gradient–intercept form
- To be able to determine the gradient and y -intercept of a straight line from gradient–intercept form
- To be able to sketch a graph using the y -intercept and the gradient

Key vocabulary: gradient–intercept form, y -intercept, gradient

Shown here is the graph of the rule $y = 2x - 1$. It shows a gradient of 2 and a y -intercept of -1 . The fact that these two numbers match numbers in the rule is no coincidence. This is why rules written in this form are called gradient–intercept form. Other examples of rules in this form include:

$$y = -5x + 2, y = \frac{1}{2}x - 0.5 \text{ and } y = \frac{x}{5} + 20.$$

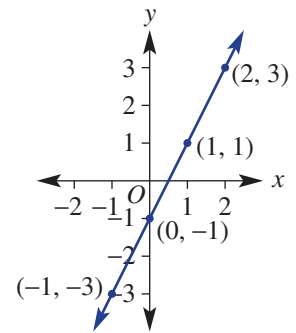

→ Lesson starter: What's in common?

Sketch the following linear relations on the same set of axes. Plot points or use the x - and y -intercepts.

a $y = 2x$

b $y = 2x + 2$

c $y = 2x - 1$

- What do these graphs have in common?
- Calculate the gradient of each line. What do you notice?
- How do the gradients relate to the rules?

Now, sketch the following linear relations on the same set of axes. Plot points or use the x - and y -intercepts.

a $y = x + 1$

b $y = 2x + 1$

c $y = -\frac{1}{2}x + 1$

- What do these graphs have in common?
- How does the common feature relate to the rules?
- Can you form a rule for a linear relation with a gradient of 3 and a y -intercept at 2?

Key ideas

$m = \text{gradient}$ $c = y\text{-intercept}$

- $y = mx + c$ (or $y = mx + b$ depending on preference) is the **gradient–intercept form** of a straight line equation.
- If the y -intercept is zero, the equation becomes $y = mx$ and these graphs will pass through the origin.
- Any linear relation can be rearranged to be written in gradient–intercept form by making y the subject.
- To sketch a graph using the gradient–intercept method, find the y -intercept and use the gradient to find a second point.
 - For example, if $m = \frac{2}{5}$, move 5 right and 2 up from the y -intercept.
 - For the gradient of $-2 = \frac{-2}{1}$ move 1 right and 2 down from the y -intercept.

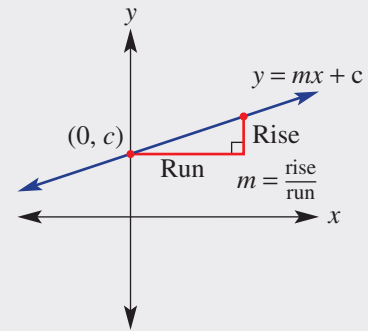

Exercise 5G

Understanding

1–4

4

- 1 Choose from the words *y-intercept*, *gradient* and *subject* to complete the following. In the gradient–intercept form, $y = mx + c$:
 - a m is the _____.
 - b c is the _____.
 - c y is the _____ of the equation.
- 2 Match the given gradient and y -intercept in the first column with the rule in the left column.

a Gradient = 2, y -intercept = 5	i $y = 5x + 2$
b Gradient = 5, y -intercept = 2	ii $y = -2x + 3$
c Gradient = -2, y -intercept = 3	iii $y = 2x + 5$
d Gradient = -1, y -intercept = -2	iv $y = -x - 2$
- 3 **a** From the point $(0, 2)$, give the coordinates of the point that is:

i 2 right and 4 up	ii 3 right and 1 down
---------------------------	------------------------------

b From the point $(0, -1)$, give the coordinates of the point that is:

i 1 right and 2 up	ii 3 right and 4 down
---------------------------	------------------------------
- 4 Fill in the missing numbers.
 - a The gradient $\frac{5}{3}$ describes a run of _____ for a rise of _____.
 - b The gradient 4 describes a run of _____ for a rise of _____.
 - c The gradient $\frac{-1}{2}$ describes a run of _____ for a rise of _____.

Hint: Plot the point to help you visualise, if required.



Hint: Gradient = $\frac{\text{rise}}{\text{run}}$
Run is always positive



5G

Fluency

5-7(1/2)

5-8(1/2)

Example 16 Stating the gradient and y -intercept

State the gradient and the y -intercept for the graphs of the following relations.

a $y = 2x - 1$

b $y = -3x$

Solution**Explanation**

a $y = 2x - 1$
The gradient = 2
 y -intercept = -1

The rule is given in gradient-intercept form, $y = mx + c$.
The gradient is the coefficient of x (the numeral multiplied by x).
The constant term is the y -intercept.

b $y = -3x$
The gradient = -3
 y -intercept = 0

The gradient is the coefficient of x including the negative sign.
The constant term is not present so the y -intercept = 0.

Now you try

State the gradient and the y -intercept for the graphs of the following relations.

a $y = 3x - 2$

b $y = -x$

- 5 State the gradient and y -intercept for the graphs of the following relations.

a $y = 3x - 4$

b $y = -5x - 2$

c $y = -2x + 3$

d $y = \frac{1}{3}x + 4$

e $y = -4x$

f $y = 2x$

g $y = 2.3x$

h $y = -0.7x$

i $y = x$

Hint:

$y = mx + c$

gradient

 y -interceptExample 17 Rearranging linear equations into the form $y = mx + c$

Rearrange these linear equations into the form $y = mx + c$.

a $2x + y = 7$

b $4x + 2y = 10$

Solution**Explanation**

a $2x + y = 7$
 $y = 7 - 2x$
 $y = -2x + 7$

To have y by itself, subtract $2x$ from both sides.
 $7 - 2x$ is the same as $-2x + 7$, which is in the form $mx + c$.

b $4x + 2y = 10$
 $2y = -4x + 10$
 $y = -2x + 5$

Solve for y by first subtracting $4x$ from both sides.
Divide both sides of the equation by 2:
 $\frac{-4x + 10}{2} = \frac{-4}{2}x + \frac{10}{2} = -2x + 5$

Now you try

Rearrange these linear equations into the form $y = mx + c$.

a $3x + y = 5$

b $6x + 3y = 9$

6 Rearrange these linear equations into the form $y = mx + c$.

a $3x + y = 4$

b $2x + y = 7$

c $y - 3x = 2$

d $y - 2x = 7$

e $5x - y = 3$

f $4x + 2y = 8$

g $3x + 2y = 6$

h $4x - 2y = 5$

i $5x - 3y = -6$

Hint: Follow steps as if you were solving an equation for y .



Example 18 Sketching linear graphs using the gradient and y -intercept

Find the value of the gradient and y -intercept for these relations and sketch their graphs.

a $y = 2x - 1$

b $y = \frac{-3}{4}x + 2$

Solution

Explanation

a $y = 2x - 1$

y -intercept = -1

Gradient = $2 = \frac{2}{1}$

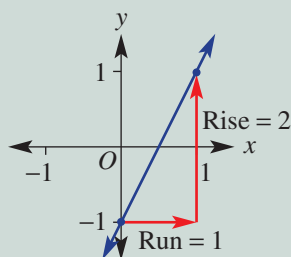

The rule is in gradient–intercept form so we can read off the gradient (coefficient of x) and the y -intercept (constant term).

Gradient = $\frac{2}{1}$ (rise) / (run); for every 1 right, move 2 up.

Label the y -intercept at $(0, -1)$.

From $(0, -1)$ move 1 to the right and 2 up to give a second point at $(1, 1)$.

Mark and join the points to form a line.

b $y = \frac{-3}{4}x + 2$

y -intercept = 2

Gradient = $\frac{-3}{4}$

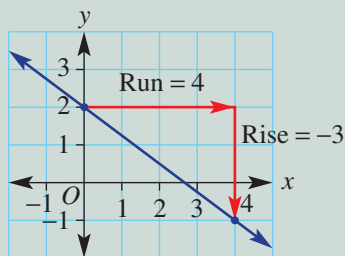

Read off the y -intercept and gradient from the gradient–intercept form.

Rise = -3 , run = 4 .

Label the y -intercept and from here move 4 across to the right (run) and 3 down (due to -3) to give a second point at $(4, -1)$. Join points to form a line.

Now you try

Find the value of the gradient and y -intercept for these relations and sketch their graphs.

a $y = 3x - 2$

b $y = \frac{-5}{4}x + 1$

7 Find the gradient and y -intercept for these relations and sketch their graphs.

a $y = x - 2$

b $y = 2x + 1$

c $y = 3x + 2$

d $y = \frac{1}{2}x + 2$

e $y = -3x + 3$

f $y = \frac{3}{2}x + 1$

g $y = 2x$

h $y = \frac{-4}{3}x$

i $y = \frac{-2}{3}x$

Hint: Plot the y -intercept first, then use the rise and run of the gradient.



5G



Example 19 Rearranging equations to sketch using the gradient and y -intercept

Rearrange the equation $x + 2y = 6$ to find the gradient and y -intercept, and sketch its graph.

Solution

$$\begin{aligned}x + 2y &= 6 \\2y &= 6 - x \\y &= 3 - \frac{1}{2}x \\&= -\frac{1}{2}x + 3\end{aligned}$$

y -intercept is 3

$$\text{Gradient} = -\frac{1}{2} = \frac{-1}{2}$$

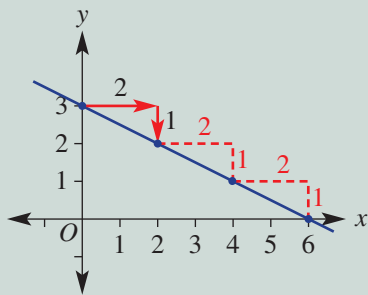

Explanation

Make y the subject by subtracting x from both sides and then dividing both sides by 2.

$$\frac{6 - x}{2} = \frac{6}{2} - \frac{x}{2} = 3 - \frac{1}{2}x$$

Rewrite in the form $y = mx + c$ to read off the gradient and y -intercept.

Link the negative sign to the rise (-1) so the run is positive ($+2$).

Mark the y -intercept and then from this point move 2 right and 1 down to give a second point at $(2, 2)$.

Note that the x -intercept will be 6. If the gradient is $-\frac{1}{2}$ then a fall of 3 needs a run of 6.

Now you try

Rearrange the equation $2x + 3y = 12$ to find the gradient and y -intercept, and sketch its graph.

- 8 Rearrange these equations to find the gradient and y -intercept and sketch their graphs.

a $x + y = 4$

b $y - x = 6$

c $4x + 2y = 6$

d $x + 2y = 8$

e $2x + 3y = 6$

f $4x + 3y = 12$

g $x - 2y = 4$

h $2x - 3y = 6$

i $3x - 4y = 12$

j $x + 4y = 0$

k $x - 5y = 0$

l $8x - 2y = 0$

Hint: Solve for y to make y the subject with equations in the form $y = mx + c$.



Problem-solving and reasoning

9, 10

10–12

- 9 During a heavy rainstorm, a rain gauge is filling with water. The rule for the volume of water in the gauge (V mL), t hours after the start of the storm, is given by $V = 4t + 2$.

a State the gradient and V -intercept of this relation and sketch its graph.

b In this scenario, what do the gradient and the V -intercept represent?

Hint: Here, the V -intercept is like the y -intercept.



- 10 Vera is trying to convince her friend Li that $\frac{4x+6}{2} = 2x+6$. She offers to pay Li \$2 if she is wrong. Does Vera lose her money? Explain.
- 11 Which of these linear relations have a gradient of 2 and y -intercept of -3 ?
- a $y = 3 - 2x$ b $y = \frac{2x-6}{2}$ c $y = \frac{4x-6}{2}$
- d $y = \frac{3-2x}{-1}$ e $2y = 4x - 3$ f $-2y = 6 - 4x$
- 12 Jeremy says that the graph of the rule $y = 2(x+1)$ has gradient 2 and y -intercept 1.
- a Explain his error.
- b What can be done to the rule to help show the y -intercept?

Hint: Rewrite each in the form $y = mx + c$ and look for $y = 2x - 3$.



The missing y -intercept

—

13

- 13 This graph shows two points $(-1, 0)$ and $(1, 4)$, with a gradient of 2. By considering the gradient (2 up for every 1 right), the y -intercept can be calculated to be 2, so $y = 2x + 2$.

Use this approach to find the rule of the line passing through these points.

- a $(-1, 1)$ and $(1, 5)$ b $(-2, 4)$ and $(2, 0)$
- c $(-2, -1)$ and $(3, 9)$ d $(-4, 1)$ and $(2, 4)$
- e $(-1, 3)$ and $(1, 4)$

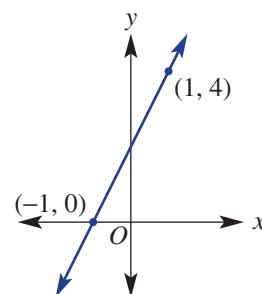

5A 1 For the rules listed below:

i Complete a table of values.

x	-3	-2	-1	0	1	2	3
y							

ii Plot a graph.

a $y = 3x + 2$

b $y = -2x + 4$

5A 2 Decide whether the point $(2, -3)$ is on the line with the given rules.

a $y = 2x - 5$

b $y = -2x + 1$

5B 3 State the coordinates of the x - and y -intercepts from the following table and graph.

a

x	-2	-1	0	1	2
y	-6	-4	-2	0	2

b

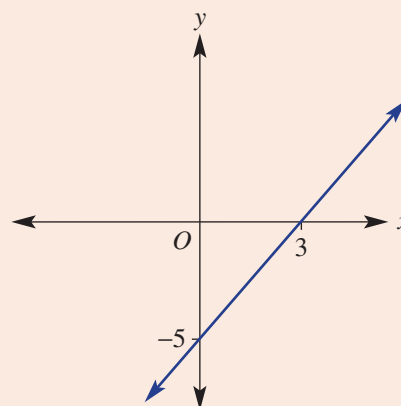

5B/5C 4 For the linear relations listed below:

i Find the y -intercept.

ii Find the x -intercept.

iii Sketch the graph showing the x - and y -intercepts.

a $y = 3x + 6$

b $y = -2x - 8$

c $2x - 5y = 10$

5C 5 A cyclist rides from school to home, with his distance from home given by the rule, $d = -\frac{1}{2}t + 10$ where d is in kilometres and t in minutes.

a Find how far school is from home ($t = 0$).

b Find how long it takes to cycle home ($d = 0$).

c Sketch a graph of the cycle from school to home, labelling intercepts.

5D 6 Sketch the graph of the following horizontal and vertical lines.

a $x = 5$

b $y = -2$

c $x = 0$

5D 7 On the one set of axes, sketch the graph of the following linear relations, which pass through the origin.

a $y = 6x$

b $y = -x$

- 5E 8 Find the gradient (m) of the following lines (where possible).

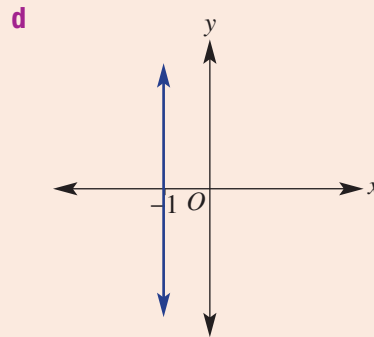
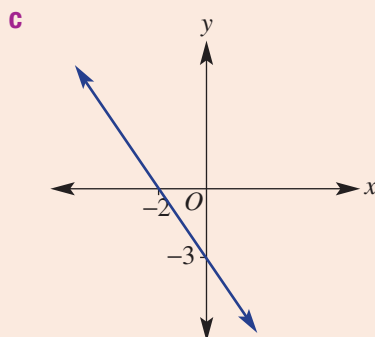
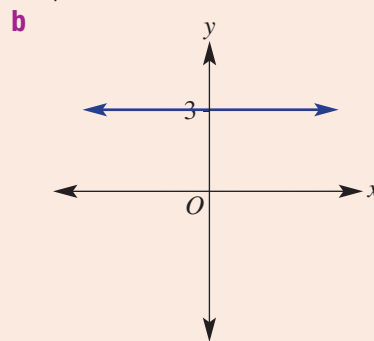
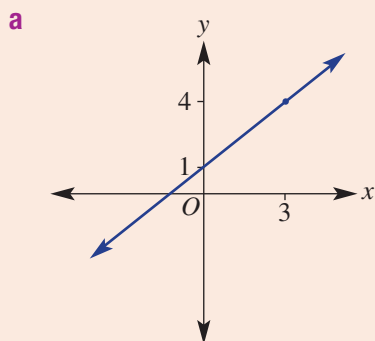

- e the line joining the points:

- i $A(2, 5)$ and $B(5, 11)$
- ii $C(-2, -4)$ and $D(1, 3)$
- iii $E(-1, 3)$ and $F(1, -7)$
- iv $G(2, 6)$ and $H(-1, 6)$

- 5F 9 Write a rule linking the given variables.

- a I travel 150 km in 3 hours. Use d for distance and t for time.
- b I earn \$80 in 5 hours. Use E for earnings and t for time.
- c A cricket team makes 160 runs off 20 overs. Use r for runs and o for overs.

- 5F 10 A birdbath is being filled with water. It takes 5 minutes to fill the bath with 300 litres.

- a What is the rate at which the birdbath is filled with water?
- b Draw a graph of volume (V litres) vs time (t minutes) using $0 \leq t \leq 5$.
- c Find:
 - i the gradient of your graph
 - ii the rule for V
- d Use your rule to find:
 - i the volume after 2 minutes
 - ii the time to fill 210 litres

- 5G 11 State the gradient and y -intercept for the graphs of the following relations. For parts d and e you will need to first rearrange the equations into the form $y = mx + c$.

- a $y = 2x - 3$
- b $y = -4x + 1$
- c $y = \frac{1}{2}x$
- d $y - 2x = 3$
- e $3y - 6x = 12$

- 5G 12 Find the value of the gradient and y -intercept for these relations and sketch their graphs.

- a $y = 3x - 2$
- b $y = -\frac{1}{2}x + 3$
- c $3x + 2y = 8$

5H Finding the equation of a line

Learning intentions

- To understand that all straight line graphs can be expressed in gradient–intercept form, $y = mx + c$
- To know that the gradient and one other point are required to find the equation of a line
- To know that all points on a line satisfy the equation of the line
- To be able to find the equation of a line given the y -intercept and another point or the gradient and a point

Key vocabulary: equation, gradient–intercept form, gradient, y -intercept

When data points from an experiment are plotted, they may form a straight line. This shows a linear relationship between the two variables, such as time and growth, involved in the experiment.

By finding the equation of this line, we can develop a rule to relate the two variables. This rule can be used to make further predictions about the data, and could be applied to a larger scale experiment.

Using gradient–intercept form, the rule (or equation) of a line can be found by calculating the value of the gradient and the y -intercept.

Lesson starter: But we don't know the y -intercept!

A line with the rule $y = mx + c$ passes through two points $(-1, 4)$ and $(1, -2)$.

- Using the information given, is it possible to find the value of m ?
If so, calculate its value.
- The y -intercept is not given on the graph. Discuss what information could be used to find the value of the constant, c , in the rule. Is there more than one way you can find the y -intercept?
- Write the rule for the line.

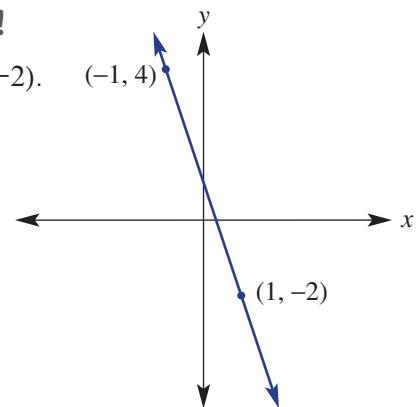

Key ideas

- To find the equation of a line in gradient–intercept form, $y = mx + c$, you need to find:
 - the value of the gradient (m) using $m = \frac{\text{rise}}{\text{run}}$
 - the value of the constant (c), by observing the y -intercept or by substituting another point.
- All the points (x, y) on a line satisfy the equation of the line.
For example, $(2, 5)$ is on the line with equation $y = 2x + 1$ since substituting $x = 2$ and $y = 5$ gives a true equation: $5 = 2 \times (2) + 1$.

Exercise 5H

Understanding

1–4

4

- Fill in the missing words.
To find the equation of a line in the form $y = mx + c$, the _____ (m) is required as well as the _____ (c) or another _____.
- Substitute the given values of m and c into $y = mx + c$ to write the rule.

a $m = 2, c = 5$	b $m = 4, c = -1$
c $m = -2, c = 5$	d $m = -1, c = -\frac{1}{2}$

- 3 Which one of the following lines does the point (3, 1) lie on?
A $y = 3x + 1$ **B** $y = x - 3$ **C** $y = -2x + 7$
D $y = 2x + 1$ **E** $y = -x - 2$

Hint: Which rule gives $y = 1$ when $x = 3$?



- 4 Substitute the point into the given rule and solve to find the value of c .
 For example, using (3, 4), substitute $x = 3$ and $y = 4$ into the rule.
a (3, 4), $y = x + c$
b (1, 5), $y = 2x + c$
c (3, -1), $y = -2x + c$

Hint: In part **a**, $4 = 3 + c$.
 $\therefore c = 1$



Fluency

5(½), 7(½)

5-7(½)



Example 20 Finding the equation of a line given the y -intercept and another point

Determine the equation of the straight line shown here.

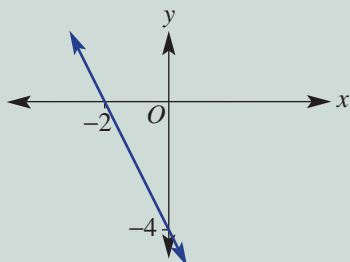

Solution

The equation will have the form
 $y = mx + c$.

$$\begin{aligned} \text{gradient, } m &= \frac{\text{rise}}{\text{run}} \\ &= \frac{-4}{2} \\ &= -2 \end{aligned}$$

$$\begin{aligned} \text{y-intercept} &= -4 \\ \therefore y &= -2x - 4 \end{aligned}$$

Explanation

For the gradient–intercept form you need to find the gradient (m) and the y -intercept (c).

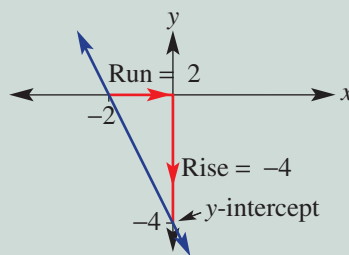

The y -intercept (-4) can be read from the graph.
 In $y = mx + c$, substitute $m = -2$ and $c = -4$.

Now you try

Determine the equation of the straight line shown here.

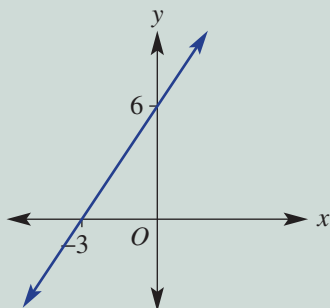

5H

5 Determine the equation of the following straight lines.

a

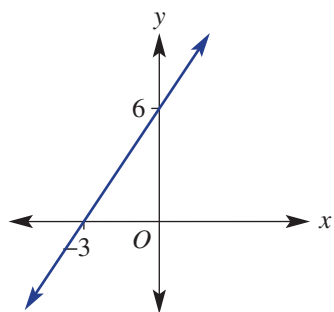

Hint: Write in the form $y = mx + c$. You will need the gradient and the y -intercept (or another point if the y -intercept is not given).



b

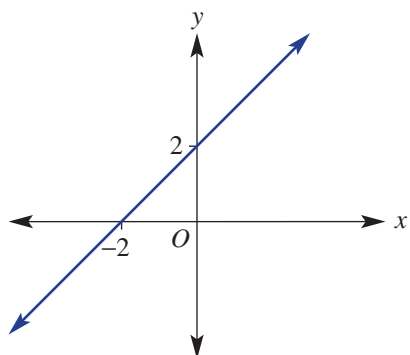

c

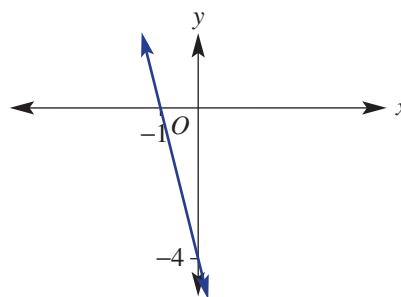

d

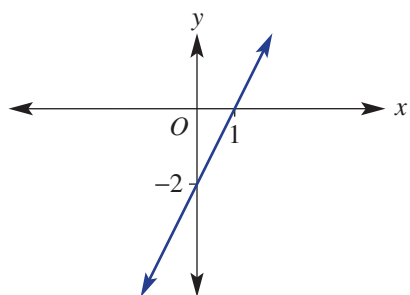

e

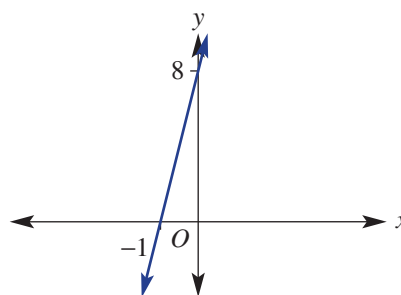

f

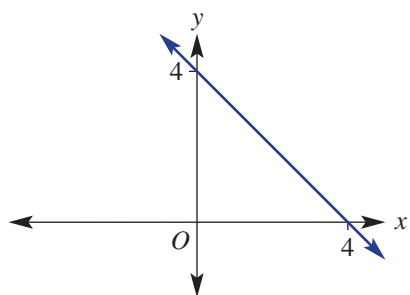

g

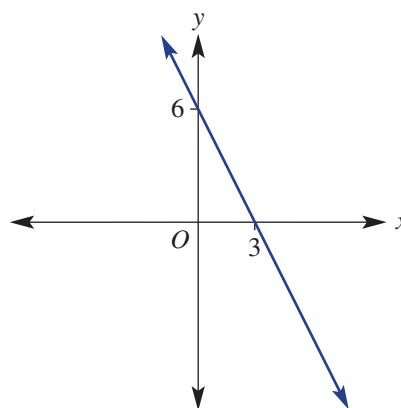

6 Find the equation of these straight lines that have fractional gradients. Simplify any fractions.

a

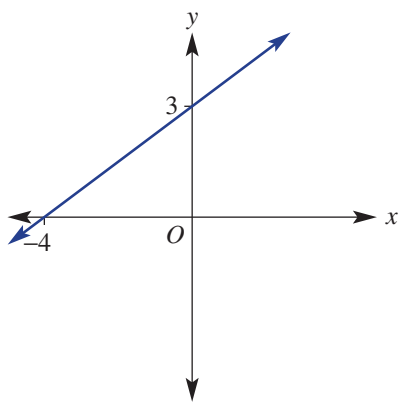

b

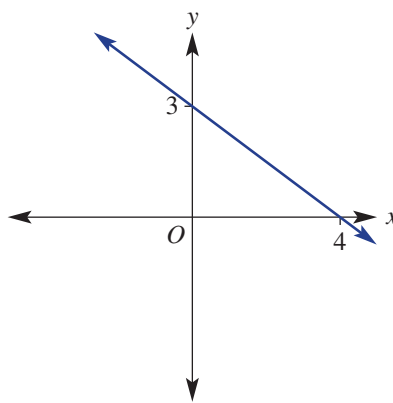

c

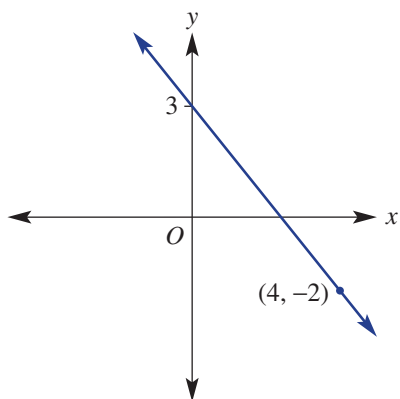

d

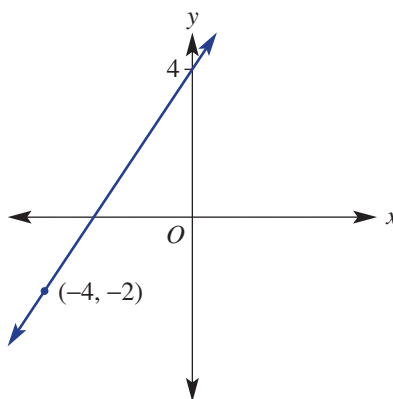

e

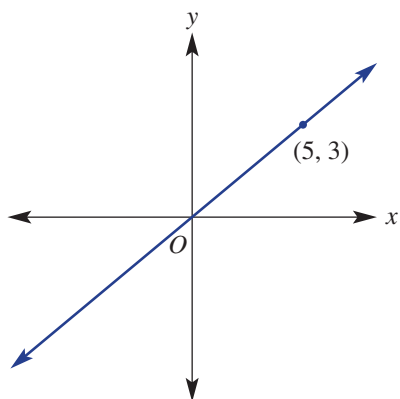

f

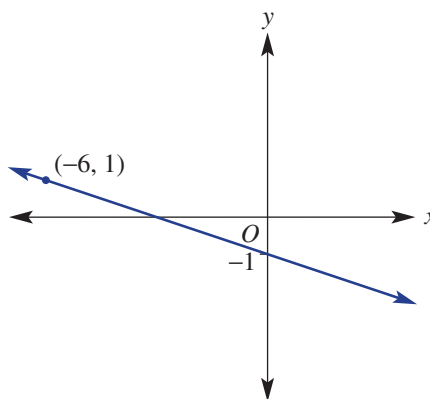

Example 21 Finding the equation of a line given the gradient and a point

Find the equation of the line that has a gradient, m , of 3 and passes through the point $(2, -1)$.

Solution

$$\begin{aligned} y &= mx + c \\ y &= 3x + c \\ -1 &= 3 \times (2) + c \\ -1 &= 6 + c \\ -7 &= c \\ \therefore y &= 3x - 7 \end{aligned}$$

Explanation

Substitute $m = 3$ into $y = mx + c$.

Since $(2, -1)$ is on the line, it must satisfy the equation $y = 3x + c$, hence substitute the point $(2, -1)$ where $x = 2$ and $y = -1$ to find c . Simplify and solve for c by subtracting 6 from both sides.

Write the equation in the form $y = mx + c$.

Now you try

Find the equation of the line that has a gradient, m , of 2 and passes through the point $(2, -1)$.

5H

- 7 Find the equation of the line that:
- a has a gradient of 3 and passes through the point (1, 8)
 - b has a gradient of -2 and passes through the point (2, -5)
 - c has a gradient of -3 and passes through the point (2, 2)
 - d has a gradient of 1 and passes through the point (1, -2)
 - e has a gradient of -3 and passes through the point (-1 , 6)
 - f has a gradient of 5 and passes through the point (2, 9)
 - g has a gradient of -1 and passes through the point (4, 4)
 - h has a gradient of -3 and passes through the point (3, -3)
 - i has a gradient of -2 and passes through the point (-1 , 4)
 - j has a gradient of -4 and passes through the point (-2 , -1)

Hint: In $y = mx + c$, insert the gradient value for m , then substitute the point for x and y to find c .



Problem-solving and reasoning

8, 9

8–11

- 8 The coordinates (0, 1) mark the take-off point 1 metre above the ground for a rocket constructed as part of a science class. The positive x direction is considered to be east. Find the equation of the rocket's path if it rises at a rate of 5 m vertically for every 1 m in an easterly direction.

- 9 A line has gradient -2 and y -intercept 5. Find its x -intercept.

Hint: First write the rule of the line.



- 10 Brad starts the year with \$80 in his bank account. He adds money into his account each week and does not take money out. After 4 weeks he has \$220 in his account. If the relationship is linear:

Hint: Plot the linear information on a graph to help.



- a find a rule for the amount of money in the account after x weeks
- b use your rule to find when he will have \$500

- 11 For the line connecting the following pairs of points:

- i find the gradient
 - ii find the equation using $y = mx + c$
- a (2, 6) and (4, 10)
 - b (1, 7) and (3, -1)
 - c (-3 , 6) and (5, -2)
 - d (-4 , -8) and (1, -3)

Hint: Compare with Example 21.



Two pieces of information make a linear rule

—

12, 13

Assume that the relationships between the variables in these questions are linear.

- 12 Water is leaking from a tank. The volume of water in the tank after 1 hour is 100 L and after 5 hours the volume is 20 L.
- a Find the equation of the line joining the points to find a rule. Use y for volume and x for time.
 - b Use the rule to state the amount of water that was in the tank to start with.
- 13 At 1 minute before midnight, the temperature inside a house in winter was -5°C . The heater was switched on at this time. Three minutes after midnight, the temperature had reached 3°C .
- a Find the rule to represent this. (Plot the points on axes and find the equation of the line joining them. Use y for temperature and x for time.)
 - b Find the x -intercept and the y -intercept.
 - c Describe what the points in part b represent in a practical sense.

51 Midpoint and length of a line segment

Learning intentions

- To know that a line segment is defined between two endpoints
- To be able to find the midpoint of a line segment given the endpoints
- To understand how Pythagoras' theorem can be used to find the length of a line segment
- To be able to find the length of a line segment

Key vocabulary: midpoint, line segment, coordinates, endpoints, average, Pythagoras' theorem, hypotenuse, horizontal, vertical, length

A line continues on forever, but a line segment (or line interval) has endpoints; this means it has a defined length and therefore must have a midpoint. Both the midpoint and length can be found by using the coordinates of the endpoints.



→ Lesson starter: Choosing a method

This graph shows a line segment between the points at $(-2, -1)$ and $(2, 3)$.

- What is the horizontal distance between the two points?
- What is the vertical distance between the two points?
- Discuss and explain a method for finding the length of a line segment, using the right-angled triangle formed.
- What is the x -coordinate of the point halfway along the line segment?
- What is the y -coordinate of the point halfway along the line segment?
- Discuss and explain a method for finding the midpoint of a line segment.

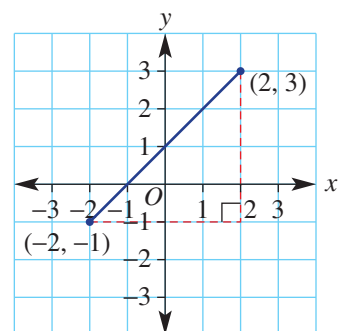

Using graphing software or dynamic geometry software, produce a line segment like the one shown above. Label the coordinates of the endpoints and the midpoint. Also find the length of the line segment. Now drag one or both of the endpoints to a new position.

- Describe how the coordinates of the midpoint relate to the coordinates of the endpoints. Is this true for all positions of the endpoints that you choose?
- Now use your software to calculate the vertical distance and the horizontal distance between the two endpoints. Then square these lengths. Describe these squared lengths compared to the square of the length of the line segment. Is this true for all positions of the endpoints that you choose?

Key ideas

■ A **line segment** is a section of a straight line between two points (**endpoints**).

■ The **midpoint** (M) of a line segment is the halfway point between the two endpoints.

- The x -coordinate is the **average** (mean) of the x -coordinates of the two endpoints.
- The y -coordinate is the average (mean) of the y -coordinates of the two endpoints.

$$M = \left(\frac{x_1 + x_2}{2}, \frac{y_1 + y_2}{2} \right)$$

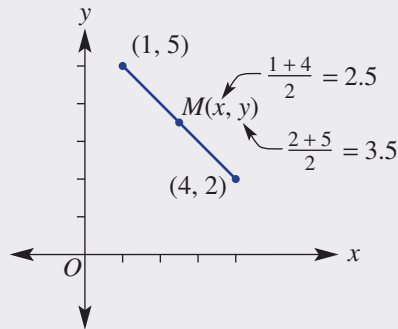

■ The **length** of a line segment (or line interval) is found using Pythagoras' theorem.

- The line segment is the hypotenuse (longest side) of a right-angled triangle.
- The coordinates can be used to find the horizontal distance between them, and the vertical distance.

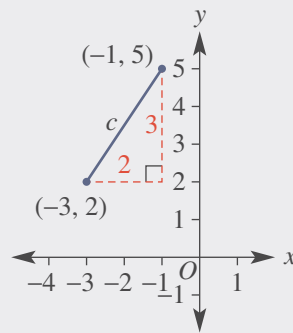

Horizontal distance from -3 to -1 is 2 .

Vertical distance from 2 to 5 is 3 .

Pythagoras' theorem:

$$c^2 = 2^2 + 3^2$$

$$= 13$$

$$\therefore c = \sqrt{13}$$

Exercise 5I

Understanding

1–3

3

- 1 Find the number that is halfway between these pairs of numbers.
- a** 5, 11 **b** $-2, 4$ **c** $-6, 0$ **d** 4, 7

Hint: If in doubt, add them and divide by 2.



- 2 Use Pythagoras' theorem to find the length of the hypotenuse in these right-angled triangles. Round to one decimal place where required.

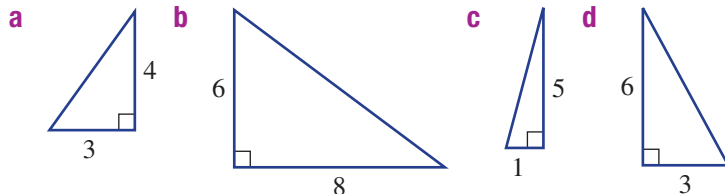

Hint: Pythagoras' theorem:

$$c^2 = a^2 + b^2$$



- 3 **a** Find the horizontal distance between the points:
- i** $(1, 4)$ and $(4, 6)$ **ii** $(-2, 3)$ and $(2, -1)$
- b** Find the vertical distance between the points:
- i** $(-2, 3)$ and $(0, 5)$ **ii** $(2, 5)$ and $(6, -2)$

Hint: For horizontal distance, consider the x -coordinates. For vertical distance, consider the y -coordinates.



Fluency

4–5(½)

4–5(½)



Example 22 Finding a midpoint

Find the midpoint $M(x, y)$ of the line segment joining these pairs of points.

a (1, 0) and (5, 4)

b (-3, -2) and (5, 3)

Solution

Explanation

a $x = \frac{1+5}{2} = 3$

$y = \frac{0+4}{2} = 2$

$\therefore M = (3, 2)$

Find the average (mean) of the x -coordinates and y -coordinates for both points.

b $x = \frac{-3+5}{2} = 1$

$y = \frac{-2+3}{2} = 0.5$

$\therefore M = (1, 0.5)$

By plotting the points to form the line segment, you can check that the coordinates you find for the midpoint appear to be the halfway point of the line segment.

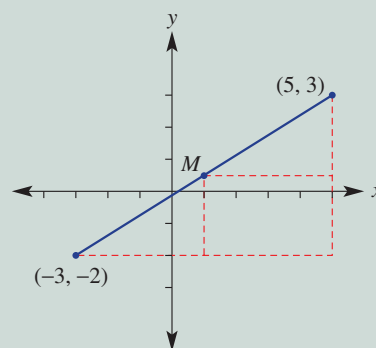

Now you try

Find the midpoint $M(x, y)$ of the line segment joining these pairs of points.

a (2, 1) and (6, 9)

b (-4, -1) and (0, 6)

4 Find the midpoint $M(x, y)$ of the line segment joining these pairs of points.

a (0, 0) and (6, 6)

c (0, 2) and (2, 8)

e (-2, 0) and (0, 6)

g (1, 3) and (2, 0)

i (-3, 7) and (4, -1)

k (-7, -16) and (1, -1)

b (0, 0) and (4, 4)

d (3, 0) and (5, 2)

f (-4, -2) and (2, 0)

h (-1, 5) and (6, -1)

j (-2, -4) and (-1, -1)

l (-4, -3) and (5, -2)

Hint: Check that your coordinates for the midpoint appear to lie halfway along the line segment.



Example 23 Finding the length of a segment

Find the length of the segment joining $(-1, 2)$ and $(4, -2)$, correct to two decimal places.

Solution

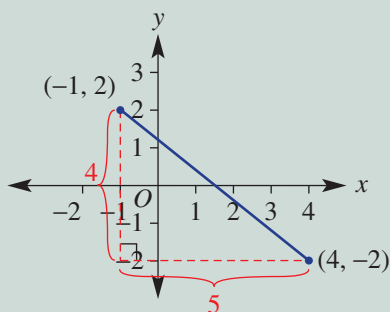

Horizontal length = 5

Vertical length = 4

$$\begin{aligned}\therefore c^2 &= 5^2 + 4^2 \\ &= 25 + 16 \\ &= 41\end{aligned}$$

$$\therefore c = \sqrt{41}$$

\therefore length = 6.40 (to 2 d.p.)

Explanation

Plot the points and form the line segment to visualise the problem.

Form the right-angled triangle.

Use the coordinates to find the lengths of the horizontal and vertical sides.

Horizontal length: from -1 to 4 is 5 units.

Vertical length: from 2 to -2 is 4 units.

Apply Pythagoras' theorem $c^2 = a^2 + b^2$.

From $c^2 = 41$, take the square root of both sides.

Round to two decimal places on a calculator as required.

Now you try

Find the length of the segment joining $(-2, 3)$ and $(1, -3)$, correct to two decimal places.



5 Find the length of the segment joining these pairs of points, correct to two decimal places.

a $(1, 1)$ and $(2, 6)$

b $(1, 2)$ and $(3, 4)$

c $(0, 2)$ and $(5, 0)$

d $(-2, 0)$ and $(0, -4)$

e $(-1, 3)$ and $(2, 1)$

f $(-2, -2)$ and $(0, 0)$

g $(-1, 7)$ and $(3, -1)$

h $(-4, -1)$ and $(2, 3)$

i $(-3, -4)$ and $(3, -1)$

Problem-solving and reasoning

6–8

7–10

- 6 A fence line on the plans for a property shows fence posts at points with coordinates $(-4, 8)$, $(2, 3)$ and $(8, -2)$. To reinforce the fence, two posts are to be placed halfway between the current posts. At what coordinates will these posts be placed?



- 7 Find the missing coordinates in this table if M is the midpoint of points A and B .

A	B	M
(4, 2)		(6, 1)
	(0, -1)	(-3, 2)
	(4, 4)	(-1, 6.5)

- 8 A circle has its centre at (2, 1). Find the coordinates of the endpoint of a diameter if the other endpoint has these coordinates.

a (7, 1) **b** (3, 6) **c** (-4, -1)

Hint: A diameter of a circle is shown:  It passes through the centre.



- 9 Find the perimeter of these shapes correct to one decimal place.

a A triangle with vertices (-2, 0), (-2, 5) and (1, 3).
b A trapezium with vertices (-6, -2), (1, -2), (0, 4) and (-5, 4).

Hint: Start by plotting the points to form the line segments that make up the shape.



- 10 For the point (3, 2) shown:

a list four points that are 3 units from this point and add them to the axes
b describe the shape that would be formed by all the points that are 3 units from (3, 2).

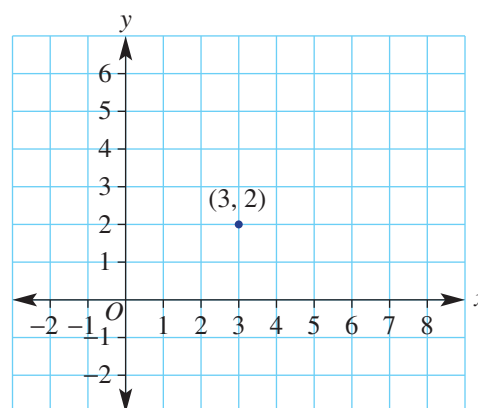

Division by ratio

—

11

- 11 Looking from left to right, this line segment shows the point $P(-1, 0)$ which divides the segment in the ratio 1 : 2.
- a** What fraction of the horizontal distance between the endpoints is P from A ?
- b** What fraction of the vertical distance between the endpoints is P from A ?
- c** Find the coordinates of point P on the segment AB if it divides the segment in these ratios.
- i** 2 : 1 **ii** 1 : 5 **iii** 5 : 1

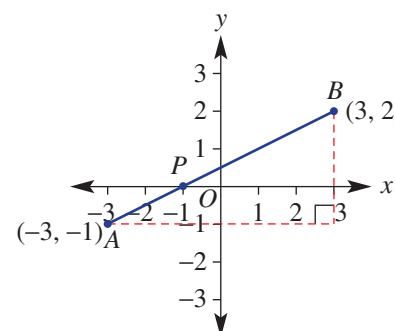

5J Linear modelling

Learning intentions

- To understand that many situations can be modelled by a linear rule or graph
- To be able to find a rule linking two variables
- To know how the dependent and independent variable are positioned on a set of axes when graphing the rule
- To be able to use a rule or graph to estimate the value of one variable given the other

Key vocabulary: dependent variable, independent variable, linear, gradient, rate

If a relationship between two variables is linear, the graph will be a straight line. The equation linking the two variables can therefore be written in gradient–intercept form. The area of mathematics which uses line graphs and rules to explore the relationship between two variables is called linear modelling. A test car, for example, increasing its speed from 100 km/h to 200 km/h in 8 seconds with constant acceleration, could be modelled by the rule $s = 12.5t + 100$. This rule could then be used to calculate the speed at different times in the test run.

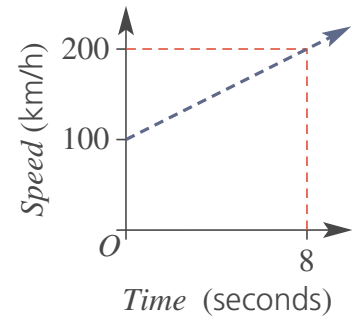

Lesson starter: The test car

The above graph describes the speed of a racing car over an 8-second period.

- Explain how the rule $s = 12.5t + 100$ for the graph is found by describing what the 100 means and what the 12.5 means.
- Why might negative values of t not be considered for the graph?
- How could you accurately calculate the speed at the 6.5 second mark?
- If the car continued to accelerate at the same rate, how could you accurately predict the car's speed at the 13.2 second mark?



Key ideas

- Many situations can often be modelled by using a linear rule or graph. The key elements of linear modelling include:
 - Finding the rule linking the two variables
 - Sketching a graph
 - Using the graph or rule to predict or estimate the value of one variable given the other
 - Finding the rate of change of one variable with respect to the other variable. This is the same as finding the gradient.
- On a set of axes the **dependent variable** goes on the vertical axis and the **independent variable** goes on the horizontal axis.
 - The dependent variable changes as a result of changes that occur in the independent variable.
 - If the variables are speed and time, then speed is on the vertical axis, since the speed reached depends on the time passed.
 - Time is usually on the horizontal axis.

Exercise 5J

Understanding

1–3

3

- 1 A person gets paid \$50 plus \$20 per hour. Decide which rule describes the relationship between the pay, $\$P$, and number of hours, n .
- A** $P = 50 + n$ **B** $P = 50 + 20n$ **C** $P = 50n + 20$ **D** $P = 20 + 50$
- 2 The amount of money in a bank account is \$1000 and it is increasing by \$100 per month.
- a** Find the amount of money in the account after:
- i** 2 months **ii** 5 months **iii** 12 months
- b** Write a rule for the amount of money, A dollars, after n months.
- 3 **a** Insert the word *independent* or *dependent* in the following.
- i** The _____ variable goes on the vertical axis.
- ii** The _____ variable goes on the horizontal axis.
- b** Choose the dependent variable in the following cases.
- i** The volume of water, V , in a tank t minutes after turning on the hose.
- ii** The height, h , of a tree t days after it was planted.
- iii** The amount of money earned from the sale of m items.

Hint: Which variable changes in response to changes in the other variable?



Fluency

4–6

4–7



Example 24 Applying linear relations

Netshare is an internet provider. It charges \$20 up front plus \$5 per week of use.

- a** Write a rule for the total cost, $\$C$, of using Netshare for t weeks.
- b** Sketch the graph of C versus t using $0 \leq t \leq 10$.
- c** What is the total cost when Netshare is used for 4 weeks?
- d** If the total cost was \$50, for how many weeks was Netshare used?

Solution

a $C = 20 + 5t$

- b** C -intercept is 20
At $t = 10$, $C = 20 + 5 \times (10) = 70$
 \therefore end point is $(10, 70)$

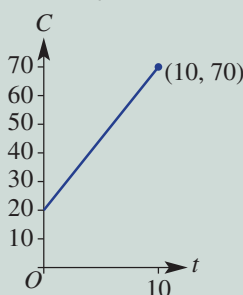

Explanation

A fixed amount of \$20 plus \$5 for each week. This is $5 \times t$.

The cost, C , is the dependent variable and so it goes on the vertical (y) axis.

Let $t = 0$ to find the C -intercept (this is the point on the vertical axis).

Letting $t = 10$ gives $C = 70$ and this gives the other endpoint.

Sketch the graph using the points $(0, 20)$ and $(10, 70)$.

Continued on next page

5J

$$\begin{aligned} \text{c } C &= 20 + 5t \\ &= 20 + 5 \times (4) \\ &= 40 \end{aligned}$$

The cost is \$40

$$\begin{aligned} \text{d } C &= 20 + 5t \\ 50 &= 20 + 5t \\ 30 &= 5t \\ \therefore t &= 6 \end{aligned}$$

Netshare was used for 6 weeks.

Substitute $t = 4$ into the rule.

Answer the question using the correct units.

Write the rule and substitute $C = 50$. Solve the resulting equation for t by subtracting 20 from both sides then dividing both sides by 5.

Answer the question in words.

Now you try

A gardener charges \$60 upfront plus \$30 per hour of work.

- Write a rule for the total cost, $\$C$, of hiring the gardener for n hours.
- Sketch the graph of C versus n using $0 \leq n \leq 6$.
- What is the total cost for a job that takes 3 hours?
- If the total cost was \$210, how many hours was the gardener hired for?

- A sales representative earns \$400 a week plus \$20 for each sale she makes.
 - Write a rule that gives the total weekly wage, $\$W$, if the sales representative makes x sales.
 - Draw a graph of W versus x using $0 \leq x \leq 40$.
 - How much does the sales representative earn if, in a particular week, she makes 12 sales?
 - If, in a particular week, the sales representative earns \$1000, how many sales did she make?
- A plumber charges a \$40 fee upfront per job, and \$50 for each hour he works.
 - Find a linear equation for the total charge, $\$C$, for n hours of work.
 - What will a 4-hour job cost?
 - If the plumber works on a job for two days and averages 6 hours per day, what will be the total cost?
- A catering company charges \$500 for the hire of a marquee (a giant tent), plus \$25 per guest.
 - Write a rule for the cost, $\$C$, of hiring a marquee and catering for n guests.
 - Draw a graph of C versus n for $0 \leq n \leq 100$.
 - How much would a party catering for 40 guests cost?
 - If a party cost \$2250, how many guests were catered for?
- The cost, $\$C$, of recording a music CD is \$300, plus \$120 per hour of studio time.
 - Write a rule for the cost, $\$C$, of recording a CD requiring t hours of studio time.
 - Draw a graph of C versus t for $0 \leq t \leq 10$.
 - How much does a recording using 6 hours of studio time cost?
 - If a recording cost \$660 to make, for how long was the studio used?

Hint: To sketch over $0 \leq x \leq 40$, find the endpoints; that is, the point where $x = 0$ and where $x = 40$.



Problem-solving and reasoning

8, 9

9–11

- 8 A petrol tank holds 66 litres of petrol. If it starts with 12 litres of petrol and the petrol pump fills it at 3 litres every 10 seconds, find:
- a linear equation for the amount of fuel (F litres) in the tank after t minutes
 - how long it will take to fill the tank.

Hint: Read units carefully. 3 L in 10 seconds equals 18 L in 1 minute.



- 9 A tank starts with 4000 L of water. Water from it is used at a rate of 20 L per minute.
- Write a rule for the volume, V litres, of water after t minutes.
 - Calculate the volume after 1.5 hours.
 - How long will it take for the tank to be emptied?
 - How long will it take for the tank to have only 500 L?

Hint: If the water is being used, think about what should be happening to the volume of water in the tank.



- 10 The rule for distance travelled, d km, over a given time, t hours, for a moving vehicle is given by $d = 50 + 80t$.
- What is the speed of the vehicle?
 - If the speed was actually 70 km per hour, how would this change the rule? Write the new rule.

- 11 The altitude, h metres, of a helicopter t seconds after it begins its descent is given by $h = 350 - 20t$.

- Use the rule to find or state:
 - the rate at which the helicopter's altitude is decreasing
 - the helicopter's initial height ($t = 0$)
 - how long it will take for the helicopter to reach the ground.
- If the rule was $h = 350 + 20t$, describe what the helicopter would be doing.

Hint: Altitude is the height above ground at which the helicopter is flying.



Where will they meet?

—

12

- 12 Car A heads out of town on the open highway travelling at an average speed of 65 km/h.
- Write a rule for the distance, d km, of the car from the town after t hours.
 - Sketch a graph of distance (d) vs time (t) for $0 \leq t \leq 5$.

At the same time as Car A leaves town, Car B sets out on the highway from the opposite direction, travelling towards the town. The rule for the distance, d km, of Car B from the town after t hours is given by $d = 350 - 75t$.

- How many kilometres from town does Car B begin?
- How long will it take for Car B to reach the town?
- Sketch the graph of the rule for Car B on the same axes that you used in part **b**.
- Using your graph, find:
 - how many hours into the journey the two cars will pass each other
 - how many kilometres out of town they will be when they pass each other.

5K Non-linear graphs

Learning intentions

- To know that non-linear rules produce graphs that are not straight lines
- To know the general form of a quadratic relation
- To know the shape of a parabola – the graph of a quadratic relation
- To know the basic features of a parabola: symmetry, intercepts and maximum or minimum turning point
- To be able to plot a parabola from a table of values

Key vocabulary: parabola, quadratic relation, turning point, axis of symmetry

So far, we have looked at linear relations and how they can be illustrated using straight line graphs.

There are also many situations and rules that produce graphs that are non-linear. These rules involve terms such as x^2 , 2^x , $\frac{1}{x}$ and so on.

One common non-linear graph is the parabola. A parabola can model the path of a ball through the air (e.g. a soccer ball after it is kicked), an object thrown from a window or the arch of a bridge. The parabola has many key features, which will be studied here.



→ Lesson starter: Finding features

Here are graphs of two types of non-linear relations, which are parabolas.

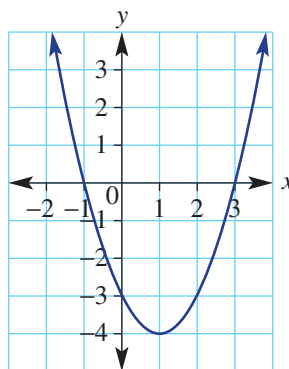
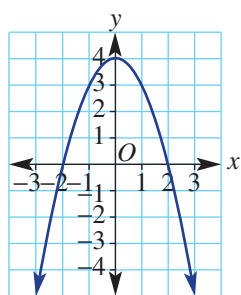

- With a partner, list what you consider to be the important features of each graph.
- Did your discussion include shape, intercepts and other key points?
- Relate the following list of words to one or both of the graphs.

symmetry	y -intercept	x -intercept
minimum	parabola	x -axis
turning point	positive	
- Decide which rule below matches each graph.

a $y = x^2 - 2x - 3$

b $y = 4 - x^2$

Key ideas

- The graph of a **quadratic relation** is called a **parabola**.
 - The basic quadratic rule is $y = x^2$ and has basic shape .
 - A quadratic relation has a general equation $y = ax^2 + bx + c$, where a , b and c are constants, with $a \neq 0$.
- A parabola is symmetrical about a line called the **axis of symmetry**, and has a minimum or maximum **turning point** (a point where the curve changes direction).

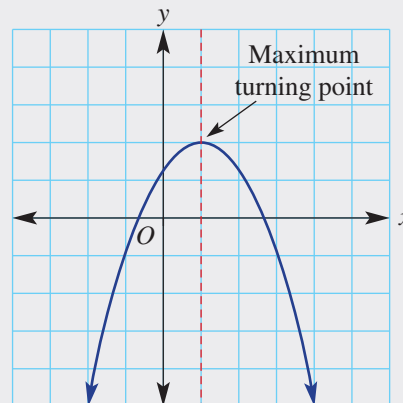
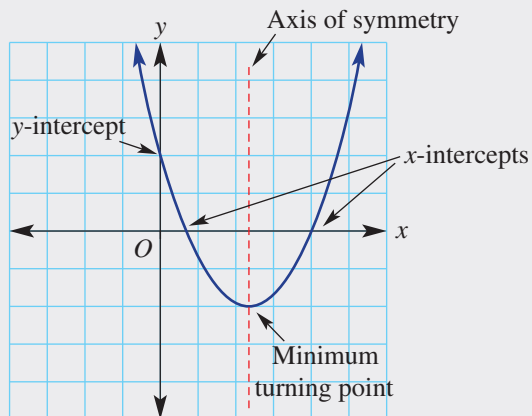

Exercise 5K

Understanding

1-3

2, 3

- 1 What is the name given to the graph of a quadratic relation?
- 2 State which of the following will produce a graph that is a parabola.

A $y = 3x^2$	B $y = x^2 - 4$	C $y = 2x + 3$
D $y = \frac{2}{x} + x^2$	E $y = 5 - x^2$	F $y = 4^x + 1$
- 3 For the parabola shown, give the coordinates of the:
 - a y-intercept
 - b x-intercepts
 - c turning point

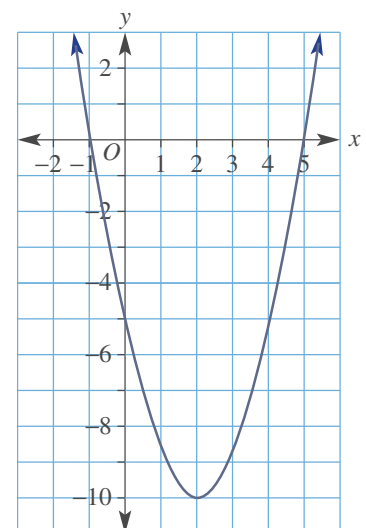



Example 25 Plotting a parabola

Complete the table of values shown and plot the points to sketch the following parabolas.

a $y = 2x^2$ **b** $y = -x^2 + 1$

x	-2	-1	0	1	2
y					

Solution

a

x	-2	-1	0	1	2
y	8	2	0	2	8

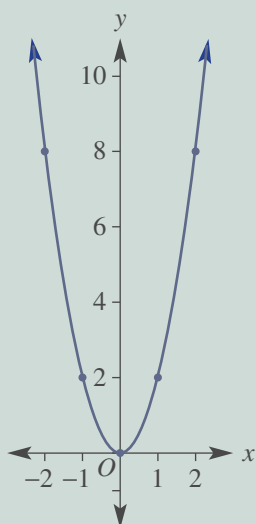

Explanation

Substitute each x value into the rule $y = 2x^2$.

For $x = 2$, $y = 2 \times (2)^2$

$$= 2 \times 4$$

$$= 8$$

For $x = -1$, $y = 2 \times (-1)^2$ Recall $(-1)^2 = -1 \times (-1) = 1$

$$= 2 \times 1$$

$$= 2$$

Plot points and join them to form a parabola.

Note that it has a minimum turning point.

b

x	-2	-1	0	1	2
y	-3	0	1	0	-3

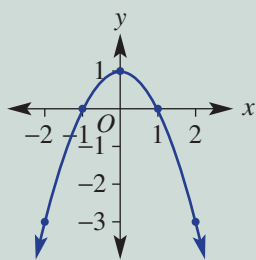

Substitute each x value into the rule $y = -x^2 + 1$.

For $x = 2$, $y = -(2)^2 + 1$ 2^2 is 4, so -2^2 is -4

$$= -4 + 1$$

$$= -3$$

For $x = -1$, $y = -(-1)^2 + 1$ $(-1)^2 = -1 \times (-1) = 1$

$$= -1 + 1$$

$$= 0$$

Plot points and join them to form a parabola with a maximum turning point.

Now you try

Complete the table of values shown and plot the points to sketch the following parabolas.

a $y = 4x^2$ **b** $y = -x^2 - 1$

x	-2	-1	0	1	2
y					

4 Complete the table of values shown and plot the points to sketch the following parabolas.

x	-2	-1	0	1	2
y					

a $y = 3x^2$

c $y = 2x^2 - 2$

e $y = -2x^2$

g $y = -2x^2 + 8$

b $y = x^2 + 2$

d $y = x^2 + 2x + 1$

f $y = -x^2 - 3$

h $y = -x^2 + 2x - 2$

5 Decide which of the quadratic rules fit the given graph:

$y = 4 - x^2$, $y = -x^2$, $y = x^2 - 1$, $y = x^2 - 4$.

a

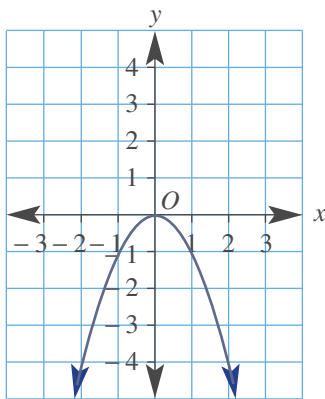

b

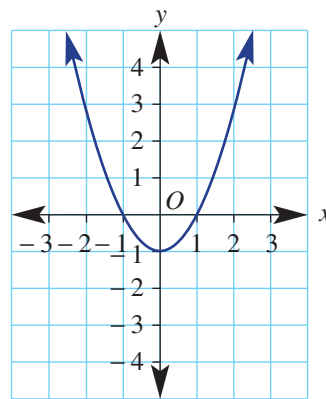

c

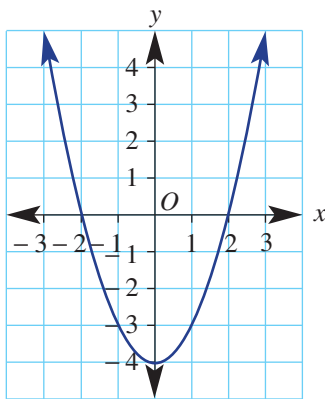

d

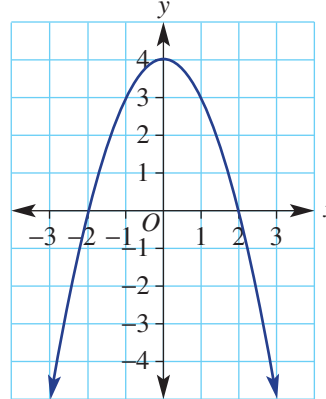

Problem-solving and reasoning

6, 7

6-8

6 Consider the four parabolas with rules shown below.

i $y = x^2 - 4$

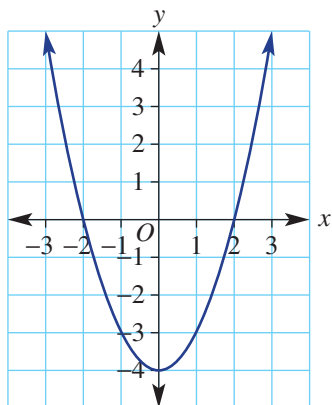

ii $y = x^2 + 2x - 1$

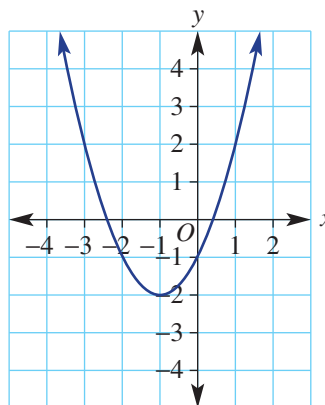

iii $y = -x^2 + 1$

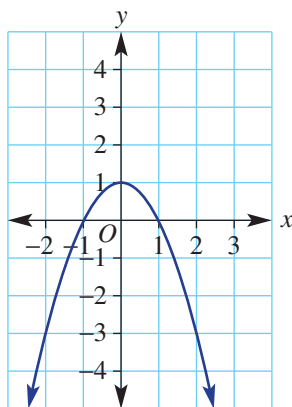

iv $y = -3x^2$

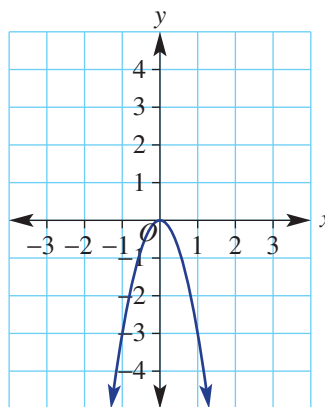

- a** For each graph, state whether it has a minimum turning point or a maximum turning point and give its coordinates.
b Given your answers to part **a**, what feature in the rule of your graph would be used to tell you if it has a maximum or minimum turning point?
c Draw in a line of symmetry (mirror line) on each graph.

Hint: Is the graph shape

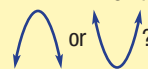

7 Match the following rules with the graphs.

a $y = 3x^2$

b $y = x^2 - 1$

c $y = x^2 + 1$

d $y = 3 - x^2$

e $y = -x^2$

A

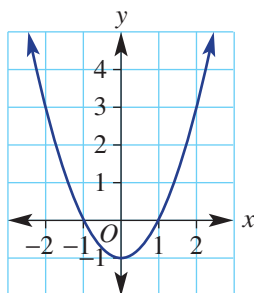

B

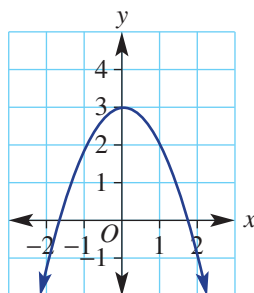

C

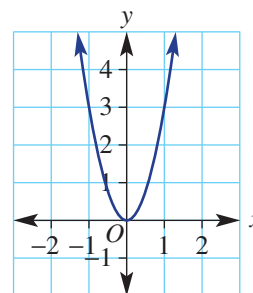

D

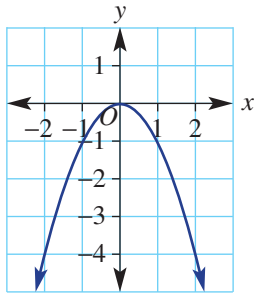

E

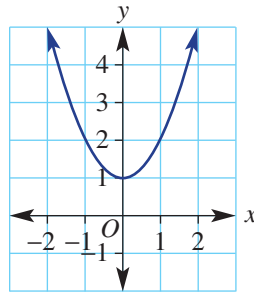

8 This graph shows the height of a cricket ball, y metres, as a function of time, t seconds.

- a i** At what times is the ball at a height of 9 m?
ii Why are there two different times?
- b i** At what time is the ball at its greatest height?
ii What is the greatest height the ball reaches?
iii After how many seconds does the ball hit the ground?

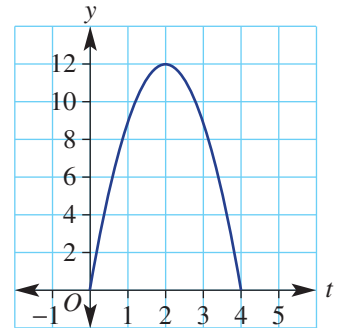

Increasing interest

9

9 This graph shows the amount of money in Yumi's bank account each month since the start of the year, as interest is added. The graph is neither linear nor parabolic, but instead exponential. These graphs are used to illustrate compounding growth.

- a** How much was in the account at the start of the year?
- b** Use the graph to find how much was in the account after:
- 1 month
 - 2 months
 - 3 months
- c** Does the account increase by the same amount each month?
- d** Find the percentage increase in the account from:
- the start to month 1
 - month 1 to month 2
 - month 2 to month 3
- e** What can you say about the percentage increase from month to month?
- f** Find the approximate amount that will be in the account after month 4.

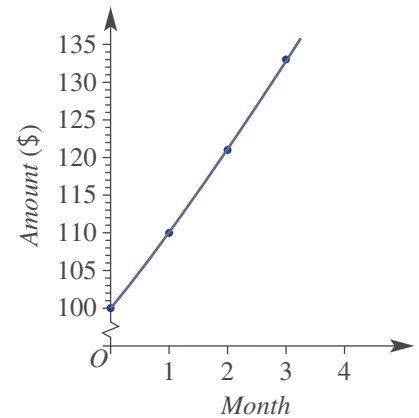



Maths@Work: Trading in foreign currencies

Many professions use linear relations to model aspects of their jobs. FOREX traders or currency traders use their knowledge of trends and future growth to buy and sell currencies from around the world.

It is the biggest market in the world. People often trade in shares, futures and overseas currencies from the privacy of their home.

Country	Unit	Rate 1	Rate 2
U.S.A.	1	7.27570	8.11720
JAPAN	1	0.06480	0.07250
CANADA	1	5.36340	6.02430
INDONESIA	1000	0.48450	0.70620
NEW ZEALAND	1	4.83290	5.55370
VIET NAM	1000	0.29640	0.43330
SWITZERLAND	1	7.20540	8.22780
UNITED ARAB	1	1.82280	
SOUTH AFRICA			

- 1 The currency of one country is directly proportional to the currency of another country. Each currency exchange can be written as an equation in the form $y = mx$. The top line of this table states that 1 euro (EUR) = 1.5687 Australian dollars (AUD). Writing this as an equation gives: $y = 1.5687 \times x$ where $x = \text{EUR}$, $y = \text{AUD}$.

	From (x : input currency)	To (y : output currency)	Exchange rate
i	The EURO (EUR)	Australian dollars (AUD)	1.5687
ii	British pounds (GBP)	AUD	2.0306
iii	USD	Chinese Yuan (CNY)	6.5181
iv	EUR	GBP	0.7725
v	AUD	EUR	0.6375
vi	AUD	United states dollar (USD)	0.7158
vii	AUD	Singapore dollar (SGD)	1.0038
viii	AUD	New Zealand dollar (NZD)	1.0753

Use the exchange rate table above to complete a table with these column headings. Work with four decimal places for the linear equation and three decimal places for y when $x = 10$ in the 'Two points' column.

x : input currency	y : output currency	Linear equation	Two points (0, $_$) and (10, $_$)

- 2 Use the information in your answer to Question 1 for the following tasks.
- For exchange rates **i** to **iv**, sketch each linear relation on a separate number plane. Label the currency on each axis and label each point where $x = 10$.
 - What feature of the straight line does the exchange rate represent in each graph?
 - For exchange rates **v** to **viii**, sketch each linear relation on the same number plane. Label each point where $x = 10$.
 - What do you notice about the slope of the line as the exchange rate increases?

Using technology

- 3 Currency rates fluctuate over time. Follow the Excel spreadsheet instructions below to graph a trendline and determine the trendline equation for the exchange rate of Australian dollars to Japanese yen.
- Enter the data from this table into an Excel spreadsheet.
 - Select both columns.
 - Choose Insert and Scatter graph and click on the icon of unconnected points.
 - Click on one of the graphed points, right click, and select 'Add trend line'.
 - From the trendline options that appear, select 'linear' and at the bottom of the callout tick 'display equation on chart'.
 - Label the graph.
 - Copy the trendline equation. Define the x and y for the trendline.
 - What does the gradient of this trendline tell us?
 - Use the trendline equation to predict the exchange rate for May 10.
 - If the exchange rate continues to follow this trend, how many Japanese yen would you expect to receive when exchanging \$1500 AUD on 15 May?
 - Give one reason why a currency trendline equation can't be relied on to make accurate predictions.

May	AUD to JPY
1	80.48545
2	80.98463
3	81.15554
4	82.53038
5	82.53038
6	83.17927
7	84.55183
8	84.55183



Running in a Triathlon

Jack, Levi and Max compete in a junior Triathlon event, first swimming 200 m, then cycling 12 km and finally running 1200 m.

Jack was the first to start the running leg and he runs at an average speed of 3 m/s. Levi runs at 3.5 m/s and Max runs at 4 m/s. However Max and Levi take longer to complete the swimming and cycling and start the run after Jack started. Can either of them overtake Jack and win the race?

For this task, d metres is the distance travelled by a runner and t seconds is the time in seconds after Jack starts running.

Present a report for the following tasks and ensure that you show clear mathematical workings, explanations and diagrams where appropriate.

Preliminary task

- Find the time, in seconds, taken to run 1200 m at an average speed of 2.4 m/s.
- Write the rule for distance d after t seconds when running at a speed of 2.4 m/s.
- A rule describing a different runner is given by: $d = 2.5t - 20$. Let $d = 1200$ and solve the equation to find this runner's finishing time.

Modelling task

The problem is to find the times of the first, second and third place runners and their time differences.

- Write down all the relevant information that will help solve this problem.
- Using a large sheet of graph paper or digital graphing software, prepare axes like those shown below. Draw and label a horizontal axis showing time t to 400 seconds and a vertical axis showing distance d to 1200 m.

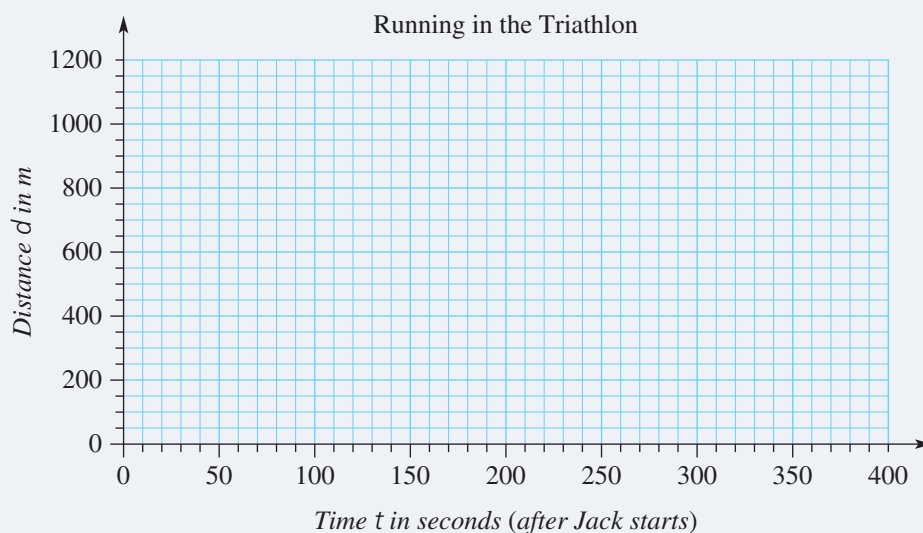

- Jack runs at an average speed of 3 m/s for the 1200 m.
 - How long, in seconds, does Jack take to run the 1200 m?
 - Write a rule for Jack's distance (d metres) in terms of time (t seconds).
 - Draw a line on the graph to represent Jack's run. Label this line: Jack.

- d** Levi starts running after Jack had started. Levi runs at 3.5 m/s and the rule describing Levi's distance d after t seconds is given by: $d = 3.5t - 175$.
- Let $d = 0$ and find t , Levi's starting time. Plot this point and label its coordinates.
 - Find Levi's distance when $t = 350$. Plot this point and label its coordinates.
 - Draw a line through these points extend it to 1200 m. Label this line: Levi.
- e** What occurs on the graph at $t = 350$? Explain what happens between Jack and Levi at 350 s.
- f** Max starts the running race behind Levi and Jack. Max runs at 4 m/s and the rule describing Max's distance d after t seconds is given by: $d = 4t - 300$.
- Let $d = 0$ and find t , Max's starting time. Plot this point and label its coordinates.
 - Find Max's distance when $t = 250$. Plot this point and label its coordinates.
 - Rule a line through these points and extend it to 1200 m. Label this line: Max.
- g** What occurs on the graph at $t = 250$? Explain what happens between Max and Levi at 250 seconds.
- h** Does Max also overtake Jack? If so, state the time and distance where this happens.
- From your graph determine who gets first, second and third place.
-
- j** Let $d = 1200$ in each equation and solve each for t to find the runner's finishing times, to the nearest second.
- k** By how many seconds was the first place runner ahead of the second runner and the third runner?
-
- l** Summarise your results and describe any key findings.

Evaluate
and
verify

Communicate

Extension question

A fourth runner, Elijah, started 80 seconds after Jack started and finished at the same time as Jack.

- a** Answer the following questions about the line on the graph that would show Elijah's run.
- State the coordinates of the start and end points that would be on Elijah's line.
 - Calculate the gradient of the line that joins these two points.
 - What feature of Elijah's running does this gradient represent?
 - The line equation is in the form: $d = mt + c$. Find the values of m and c and hence the equation of the line that would represent Elijah's run.



- 1 Matches are arranged by a student such that the first three diagrams in the pattern are:



How many matches are in the 50th diagram of the pattern?

- 2 The first three shapes in a pattern made with matchsticks are:

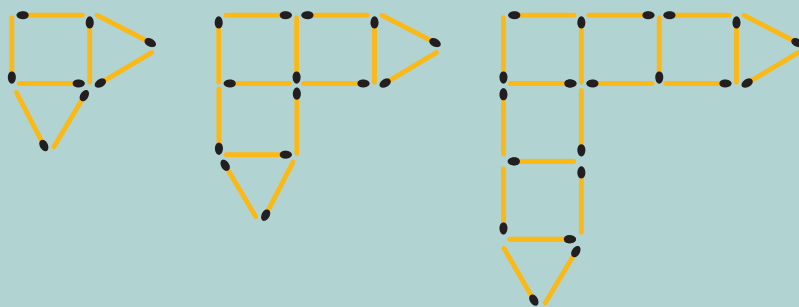

How many matchsticks make up the 100th shape?

- 3 A tank with 520 L of water begins to leak at a rate of 2 L per day. At the same time, a second tank is being filled at a rate of 1 L per hour starting at 0 L. How long does it take for the tanks to have the same volume?
- 4 The points $(-1, 4)$, $(4, 6)$, $(2, 7)$ and $(-3, 5)$ are the vertices of a parallelogram. Find the midpoints of its diagonals. What do you notice?
- 5 Prove that the triangle with vertices at the points $A(-1, 3)$, $B(0, -1)$ and $C(3, 2)$ is isosceles.

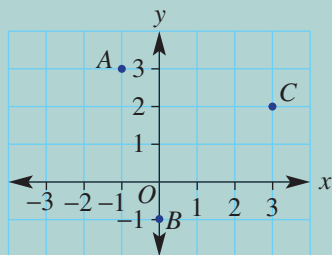

- 6 Bill takes 3 days to paint a house. Rashid takes 4 days to paint a house. Lucy takes 5 days to paint a house. How long would it take to paint a house (to the nearest hour) if all three of them worked together?



Direct proportion

$y = mx$ means y is directly proportional to x .
 $m = \text{gradient}$; the rate of change of y with respect to x .
 e.g. travelling at 60 km/h for t hours, distance $d = 60t$.

Gradient

This measures the slope of a line.

Positive
Negative
Zero
Undefined

Gradient $m = \frac{\text{rise}}{\text{run}}$

e.g. $m = \frac{4}{2} = 2$

Finding the equation of a line ★

Gradient–intercept form ($y = mx + c$)
 Require gradient and y -intercept or any other point to substitute.
 E.g.

$m = \frac{\text{rise}}{\text{run}} = \frac{2}{1} = 2$
 y -int is -2
 $\therefore y = 2x - 2$

Midpoint and length of line segment

Midpoint is halfway between segment endpoints.
 $M = \left(\frac{x_1 + x_2}{2}, \frac{y_1 + y_2}{2} \right)$
 E.g. midpoint of segment joining $(-1, 2)$ and $(3, 6)$
 $x = \frac{-1+3}{2} = 1$
 $y = \frac{2+6}{2} = 4$, i.e. $(1, 4)$

Length of segment
 Use Pythagoras' theorem $c^2 = a^2 + b^2$
 E.g.

$c^2 = 4^2 + 5^2$
 $c = \sqrt{41}$
 $c = 6.4$ (to 1 d.p.)

Linear modelling ★

Define variables to represent the problem and write a rule relating the two variables.

Straight line

$y = mx + c$

gradient m y -intercept c

In the form $ax + by = d$, rearrange to $y = mx + c$ form to read off gradient and y -intercept.

Lines with one intercept

Horizontal line $y = c$
 e.g. $y = 3$

Vertical line $x = b$
 e.g. $x = 2$

$y = mx$ passes through the origin, substitute $x = 1$ to find another point, e.g. $y = 3x$

x- and y-intercepts

x -intercept where line cuts x -axis
 y -intercept where line cuts y -axis

E.g. for $2x + 3y = 6$
 y -int ($x = 0$)
 $2(0) + 3y = 6$
 $3y = 6$
 $y = 2$
 y -int is 2

x -int ($y = 0$)
 $2x + 3(0) = 6$
 $2x = 6$
 $x = 3$
 x -int is 3

x -intercept has y -coordinate 0.
 y -intercept has x -coordinate 0.

Linear relations

Sketching linear graphs

Sketch with two points. Often we find the x -intercept ($y = 0$) and y -intercept ($x = 0$)
 E.g. $y = 2x - 4$
 y -int: $x = 0, y = 2(0) - 4 = -4$
 x -int: $y = 0, 0 = 2x - 4$
 $2x = 4$
 $x = 2$

Plot these points and join in a line.

Non-linear graphs

These include graphs of quadratic relations.

- graph shape: parabola
- equation form: $y = ax^2 + bx + c, a \neq 0$

turning point

A linear relation is made up of points (x, y) that form a straight line when plotted, e.g. $y = 2x + 1$

x	-2	-1	0	1	2
y	-3	-1	1	3	5

Chapter checklist

A version of this checklist that you can print out and complete can be downloaded from your Interactive Textbook.

5A

1 I can plot points to graph a straight line.

e.g. Complete the table of values below for the rule $y = -2x + 1$ and plot a graph.

x	-2	-1	0	1	2
y					

5A

2 I can decide whether a point is on a line.

e.g. Decide whether the point $(2, -1)$ is on the line with the given rules:

a $y = 2x - 3$ **b** $y = 3x - 7$

5B

3 I can identify x - and y -intercepts.

e.g. Read off the x -intercept and y -intercept from this table and graph

a

x	-2	-1	0	1	2
y	12	8	4	0	-4

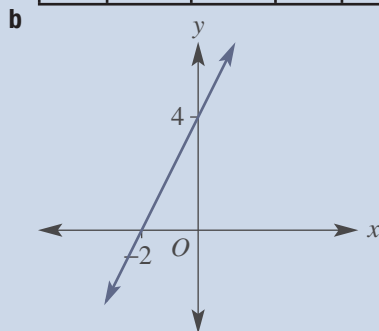

5B

4 I can find the y -intercept.

e.g. Find the y -intercept for the linear relations:

a $y = 3x - 4$ **b** $4x - 5y = 20$

5B

5 I can find the x -intercept.

e.g. Find the x -intercept for the linear relations:

a $y = 3x - 4$ **b** $4x - 5y = 20$

5C

6 I can sketch linear relations of the form $ax + by = d$ using intercepts.

e.g. Sketch the graph of $2x + 7y = 14$, showing the x - and y -intercepts

5C

7 I can sketch linear relations of the form $y = mx + c$ using intercepts.

e.g. Sketch the graph of $y = 3x - 9$ showing the x - and y -intercepts

5D

8 I can graph vertical and horizontal lines.

e.g. Sketch the graph of the following vertical and horizontal lines

a $y = -2$ **b** $x = 5$ **c** $y = 0$

5D

9 I can sketch lines that pass through the origin.

e.g. Sketch the graph of $y = 5x$





5D

10 I can find the equation of horizontal and vertical lines.

e.g. Give the equation of the following vertical and horizontal lines

a

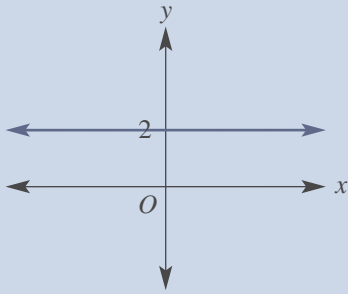

b

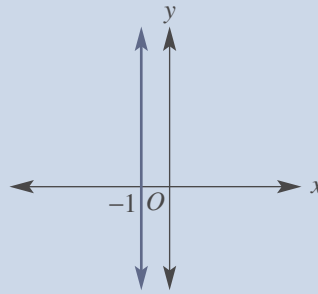

5E

11 I can find the gradient of a line.

e.g. For each graph, state whether the gradient is positive, negative, zero or undefined then find the gradient where possible.

a

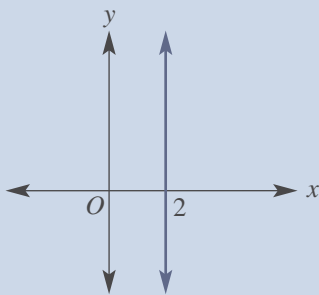

b

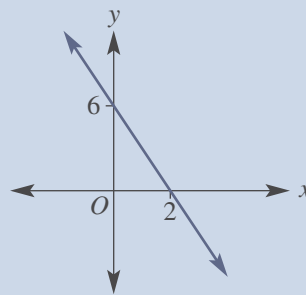

5E

12 I can find the gradient between two points.

e.g. Find the gradient (m) of the line joining the points: $A(-2, 3)$ and $B(1, 7)$

5F

13 I can form a direct proportion rule.

e.g. Write a rule linking the variables d km and t hours if I travelled 420 km in 7 hours.

5F

14 I can work with direct proportion.

e.g. A 400 L aquarium is filled with water. It takes 40 minutes to fill the tank.

a Draw a graph of volume (V litres) vs time (t minutes) using $0 \leq t \leq 40$.

b Find the gradient of the graph and form a rule for V .

c Use the rule for V to find the time to fill 250 L.

5G

15 I can state the gradient and y -intercept from $y = mx + c$.

e.g. State the gradient and the y -intercept for the graph of $y = 3x - 2$.

5G

16 I can rearrange linear equations into the form $y = mx + c$.

e.g. Rearrange these linear equations into the form $y = mx + c$:

a $3x + y = 4$ **b** $6x + 2y = 12$

5G

17 I can sketch linear graphs using the gradient and y -intercept.

e.g. Find the value of the gradient and y -intercept for these relations and sketch their graphs:

a $y = 4x - 3$ **b** $3x + 2y = 10$ (rearrange first)



5H

18 I can find the equation of a line given the y -intercept and another point.

e.g. Determine the equation of the straight line shown here.

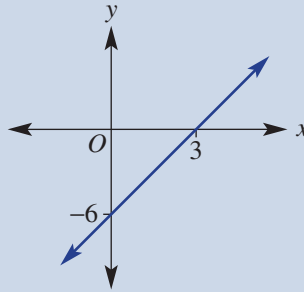

5H

19 I can find the equation of a line given the gradient and a point.

e.g. Find the equation of the line that has a gradient, m , of 2 and passes through the point $(3, -2)$.

5I

20 I can find the midpoint of a line segment.

e.g. Find the midpoint $M(x, y)$ of the line segment joining $(1, -1)$ and $(5, 6)$.

5I

21 I can find the length of a line segment.

e.g. Find the length of the segment joining $(-2, 1)$ and $(3, 5)$ correct to two decimal places.

5J

22 I can apply linear relations.

e.g. A wedding photographer charges a \$200 upfront fee plus \$80 per hour.

a Write a rule for the total cost, $\$C$, of hiring the photographer for t hours.

b Sketch the graph of C vs t using $0 \leq t \leq 6$.

c Determine the total cost if the photographer is hired for 4 hours, and how many hours the photographer is hired for if the cost is \$400.

5K

23 I can plot a parabola.

e.g. Complete the table of values shown and plot the points to sketch the following parabolas:

a $y = 3x^2$ **b** $y = -x^2 - 2$

x	-2	-1	0	1	2
y					



Short-answer questions

5A **1** Using $-2 \leq x \leq 3$, construct a table of values and plot a graph for $y = 2x - 3$.

5B **2** Read off the x - and y -intercepts from the table and graph.

a

x	-2	-1	0	1	2
y	0	2	4	6	8

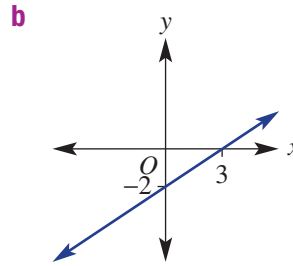

5C **3** Sketch the following linear graphs, labelling x - and y -intercepts.

a $y = 2x - 4$

b $y = 3x + 9$

c $y = -2x + 5$

d $y = -x + 4$

e $2x + 4y = 8$

f $4x - 2y = 10$

g $2x - y = 7$

h $-3x + 6y = 12$

5D **4** Sketch the following lines with one intercept and classify their gradient as positive, negative, zero or undefined.

a $y = 3$

b $y = -2$

c $x = -4$

d $x = 5$

e $y = 3x$

f $y = -2x$

5E **5** Find the gradient of the following lines.

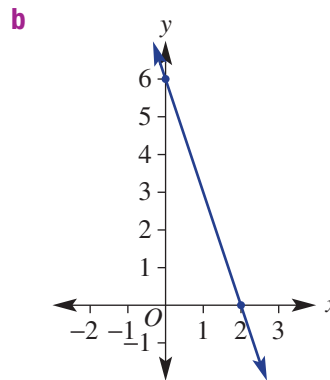
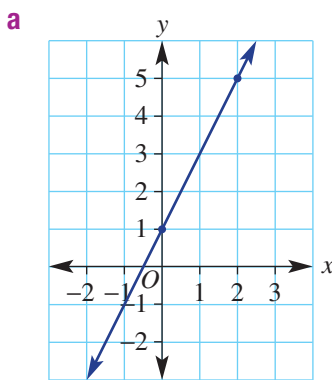

5E **6** Find the gradient of the line passing through these points.

a (3, 1) and (5, 5)

b (2, 5) and (4, 3)

c (-3, -2) and (1, 6)

d (-2, 6) and (1, -4)

5F **7** An empty swimming pool is being filled with water by a hose. It takes 4 hours to fill 8000 L.

a What is the rate at which water is poured into the pool?

b Draw a graph of volume (V litres) vs time (t hours) for $0 \leq t \leq 4$.

c By finding the gradient of your graph, give the rule for V in terms of t .

d Use your rule to find the time to fill 5000 L.



5G 8 For each of the following linear relations, state the value of the gradient and the y -intercept and then sketch using the gradient–intercept method.

a $y = 2x + 3$

b $y = -3x + 7$

5G 9 Rearrange the following equations into the form $y = mx + c$ and state the gradient and y -intercept.

a $2x + y = 6$

b $x + 2y = 4$

5H 10 Find the equations of these linear graphs in the form $y = mx + c$.



a

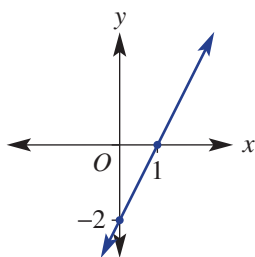

b

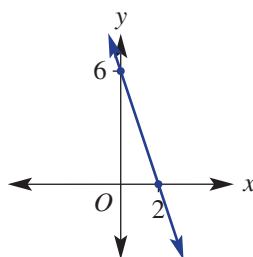

c

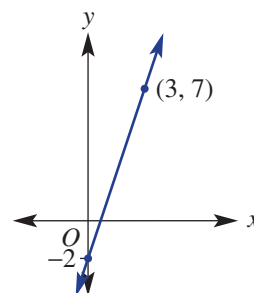

5H 11 Give the equation of the straight line that:



a has gradient 3 and passes through the point (1, 4)

b has gradient -2 and passes through the point (2, -1)

5I 12 For the line segment joining the following pairs of points, find:



i the midpoint

ii the length (to two decimal places)

a (2, 4) and (6, 8)

b (5, 2) and (10, 7)

c (-2 , 1) and (2, 7)

d (-5 , 7) and (-1 , -2)

5K 13 For the following relations, construct a table of values for $-2 \leq x \leq 2$ and plot the points on a graph.

a $y = 2x^2$

b $y = 4 - x^2$

Multiple-choice questions

5A 1 The point(s) on the Cartesian plane shown with an x -coordinate of 2 are:

A B only

B A only

C C, D and E

D B and D

E E and D

5B 2 The coordinates of the x -intercept of the graph of $2x + 4y = 12$ are:

A (4, 0)

B (0, 3)

C (6, 0)

D (2, 0)

E (0, 2)

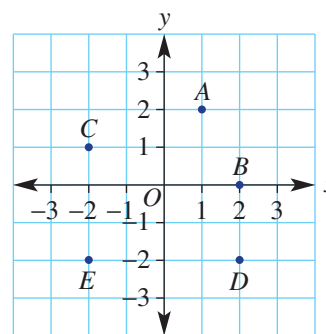

5C 3 The graph of $y = 3x - 6$ is represented by:

A

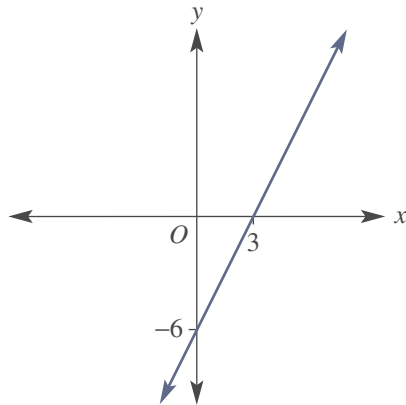

B

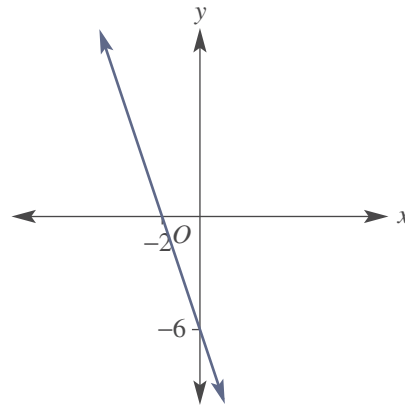

C

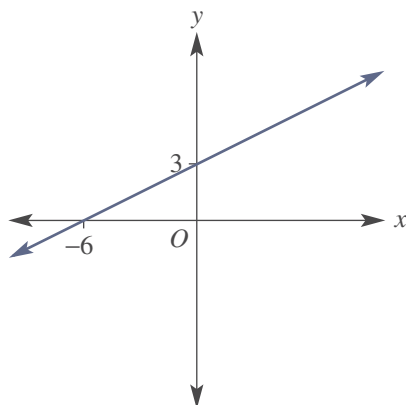

D

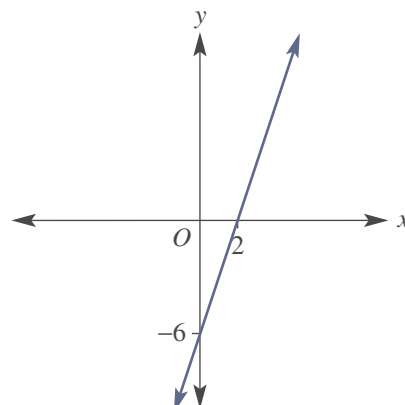

E

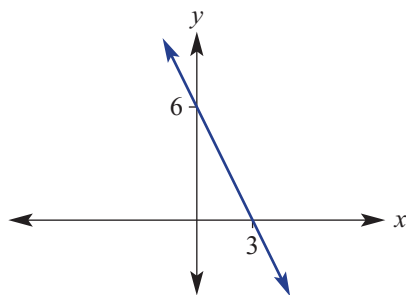

5C 4 The point that is not on the straight line $y = 2x - 1$ is:

A (1, 1)

B (0, -1)

C (3, 5)

D (-2, 7)

E (-1, -3)

5E 5 The gradient of the line joining the points (1, -2) and (5, 6) is:

A 2

B 1

C 3

D -1

E $\frac{1}{3}$

5D 6 The graph shown has equation:

A $y = x - 2$

B $y = -2x$

C $y = -2$

D $x = -2$

E $x + y = -2$

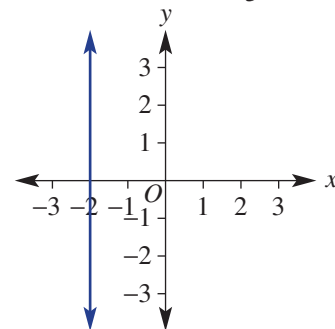

5H 7 A straight line has a gradient of -2 and passes through the point (0, 5). Its equation is:

A $2y = -2x + 10$

B $y = -2x + 5$

C $y = 5x - 2$

D $y - 2x = 5$

E $y = -2(x - 5)$



5H 8 The equation of the graph shown is:



A $y = x + 1$

B $y = \frac{1}{2}x + 4$

C $y = 2x + 1$

D $y = -2x - 1$

E $y = \frac{1}{2}x + 2$

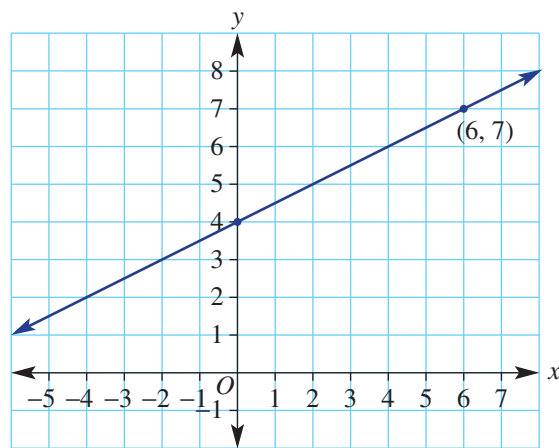

5I 9 The length of the line segment joining the points $A(1, 2)$ and $B(4, 6)$ is:

A 5

B $\frac{4}{3}$

C 7

D $\sqrt{5}$

E $\sqrt{2}$

5J 10 A satellite phone call costs a 20c connection fee plus 60c per minute. A rule to represent the cost, C cents, of a call lasting n minutes is:



A $C = 20n + 60$

B $n = 60C + 20$

C $C = 60n + 20$

D $n = 20C + 60$

E $20C + 60n = 1$

Extended-response questions



- 1 Justin is hiring a clown for his son's birthday party. The clown charges a booking fee of \$100 as well as \$50 per hour at the party.
- Write a rule for the cost (C dollars) of hiring the clown for t hours.
 - Sketch a graph of cost (C) vs time (t) for $0 \leq t \leq 5$.
 - How much will it cost to hire the clown for 4 hours?
 - At the end of the party, Justin writes out a cheque for \$225. How long was the clown at the party for?
- 2 Luca runs a marathon at a constant speed. The distance, d km, he has remaining in the marathon t hours after the start is given by $d = 42 - 14t$.
- Find the t - and d -intercepts for the rule and sketch its graph between these points.
 - What is the distance of the marathon?
 - How long does Luca take to run the marathon?
 - Find the gradient of the graph.
 - What speed is Luca running at?



Reviewing number

Short-answer questions

1 Evaluate the following.

a $\frac{3}{7} + \frac{1}{4}$

b $\frac{13}{10} - \frac{3}{10}$

c $2\frac{1}{4} + \frac{1}{2}$

d $2\frac{1}{3} - 1\frac{5}{9}$

2 Evaluate:

a $\frac{9}{10} \times \frac{5}{12}$

b $3\frac{3}{4} \div 2\frac{1}{12}$

3 Round the following to three decimal places.

a 4.1255

b 21.00241

c 0.0096

4 Divide \$800 into the following ratios.

a 1 : 4

b 2 : 3

c 7 : 1

5 Write these rates and ratios in simplest form.

a Prize money is shared between two people in the ratio 60 : 36.

b Jodie travels 165 km in 3 hours.

c 30 mL of rain falls in $1\frac{1}{4}$ hours.



6 A car averages 68 km/h on a journey. How far will it travel at this speed for 2 hours and 40 minutes? Round to one decimal place.

7 The height of a tree is directly proportional to its width. A tree that is 2 metres tall has a width of 0.6 metres. How tall is a tree with width 1.2 metres?

Multiple-choice questions

1 $7 \times (-5) + 3 \times (-4)$ is equal to:

A 23

B -47

C 47

D -23

E 420

2 $45.5 \div 9.5$, by first using rounding to one significant figure, gives:

A 4.9

B 5.35

C 5.4

D 5

E 4.95

3 \$450 is divided in the ratio 4 : 5. The value of the smaller portion is:

A \$210

B \$250

C \$90

D \$200

E \$220

4 Con runs 4.5 km in 20 minutes. His speed is:

A 1.5 km/h

B 1.5 km/min

C 13.5 km/h

D 90 km/h

E 22.5 km/h

5 $\frac{7}{10\,000} + \frac{13}{100}$ is equal to:

A 0.713

B 0.0713

C 0.1307

D 0.83

E 7.13

Extended-response questions

Thomas walks, on average, 6 km an hour. Phillip walks at an average speed of 8 km/h.

a How far does Thomas walk in 4 hours?

b Phillip starts at 8 a.m.

i If he stops at 9.45 a.m, how far has he walked?

ii What time will Phillip finish his walk if he walks twice as far as Thomas did in part **a**?

Financial mathematics

Short-answer questions

- Convert each of the following to a percentage.
 a 0.6 b $\frac{5}{16}$ c 2 kg out of 20 kg d 75c out of \$3
- Find:
 a 10% of \$96 b 85% of \$900 c $5\frac{1}{2}\%$ of \$200
- a Increase 80 m by 5%. b Decrease \$54 by 6%.
- Julie spends 20% of her day (24 hours) reading a novel. How many hours and minutes did she spend reading?
- Jamal earns a weekly retainer of \$400 plus 6% of the sales he makes. If he sells \$8200 worth of goods, how much will he earn for the week?
- Clive's salary is \$84 800 and the taxation rate for his salary is 26% for the amount above \$18 200, which is tax free. Calculate Clive's net income for the year.
- Sean invests \$800 at 6% p.a. for 18 months.
 a Calculate his simple interest.
 b What is the final balance on Sean's account after the interest has been paid?

Multiple-choice questions

- $2\frac{1}{2}\%$ is the same as:
 A 0.25 B $\frac{1}{40}$ C $\frac{25}{100}$ D 2.5 E $\frac{5}{2}$
- If cost price = \$36 and selling price = \$28.80, the percentage loss is:
 A 7.2% B 80% C 92.8% D 20% E 2%
- The simple interest earned on \$660 invested at 5% p.a. for $1\frac{1}{2}$ years is:
 A \$49.50 B \$40.50 C \$594 D \$33 E \$709.50
- A book that costs \$27 is discounted by 15%. The new price is:
 A \$20.25 B \$31.05 C \$4.05 D \$22.95 E \$25.20
- Anna is paid a normal rate of \$12.10 per hour. If in a week she works 6 hours at the normal rate, 2 hours at time and a half and 3 hours at double time. How much does she earn?
 A \$181.50 B \$145.20 C \$193.60 D \$175.45 E \$163.35

Extended-response questions

- Jill plans to trial a simple interest plan. Before investing her money she increases the amount in her account by 20% to \$21 000.
 a What was the original amount in her account?
 b She invests the \$21 000 for 4 years at a simple interest rate of 3% p.a. How much does she have in her account at the end of the four years?
 c She continues with the plan in part b and after a certain number of years has obtained \$5670 interest. For how many years has she had the money invested?
 d What percentage increase does this interest in part c represent on her initial investment?

Expressions and equations

Short-answer questions

1 Simplify the following.

a $2x + 6y - 4x + y$

b $-3m \times 5n$

c $\frac{6xy}{18x}$

2 Solve the following equations.

a $3x + 7 = 25$

b $\frac{x-1}{4} = 2$

c $4(2m + 3) = 15$

d $5a - 8 = 3a - 2$



3 Noah receives m dollars pocket money per week. His older brother Jake gets 1 dollar more than twice Noah's amount. If Jake receives \$15:

a write an equation to represent the problem using the variable m

b solve the equation in part **a** to determine how much Noah receives each week.



4 The formula $S = \frac{n}{2}(a + l)$ gives the sum, S , of a sequence of n numbers with first term a and last term l .

a Find the sum of the sequence of 10 terms 2, 5, 8, ..., 29.

b If a sequence of 8 terms has a sum of 88 and a first term equal to 4, use the formula to find the last term of this sequence.

Multiple-choice questions

1 The expression that represents 3 more than half a certain number, n , is:

A $\frac{1}{2}n + 1.5$

B $2n + 3$

C $\frac{3}{2}n$

D $\frac{n}{2} + 3$

E $\frac{n+3}{2}$

2 The simplified form of $5ab + 3a + 2ab - a$ is:

A $9ab$

B $10ab + 3a$

C $13ab - a$

D $7ab + 3$

E $7ab + 2a$

3 The expanded form of $-2(3m - 4)$ is:

A $-6m + 8$

B $-6m + 4$

C $-6m - 8$

D $-5m - 6$

E $5m + 8$

4 The solution to $\frac{d}{4} - 7 = 2$ is:

A $d = -20$

B $d = 15$

C $d = 36$

D $d = 1$

E $d = 30$



5 The formula $m = \sqrt{\frac{b-1}{a}}$, with $b = 9$ and $a = 2$, gives m equals:

A 3

B $\frac{3}{2}$

C 2

D $\sqrt{3}$

E $\frac{\sqrt{3}}{2}$

Extended-response questions



Chris and his brother Michael play basketball. In the last game, Chris scored 12 more points than Michael. Between them they scored 38 points. Let p be the number of points scored by Michael.

a Write an expression for the number of points scored by Chris.

b Write an equation involving the unknown, p , to represent the problem.

c Solve the equation to find the number of points scored by each of Chris and Michael.



Pythagoras' theorem and trigonometry

Short-answer questions

 1 Find the value of each pronumeral, correct to one decimal place.

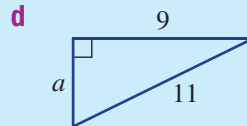
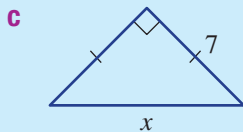
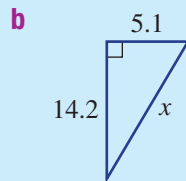
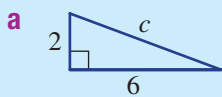

 2 Find the value of each pronumeral correct to one decimal place.

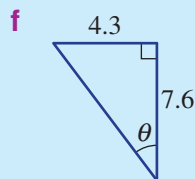
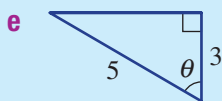
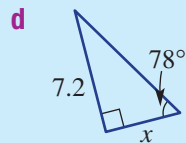
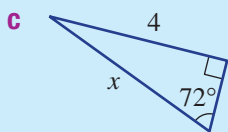
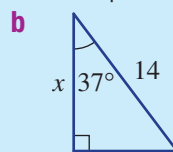
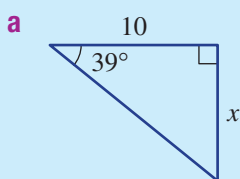

 3 A wire is to be connected from the edge of the top of a 28 m high building to the edge of the top of a 16 m high building. The buildings are 15 m apart.

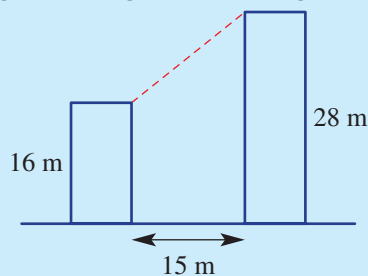

- a** What length of wire is required? Round to two decimal places.
b What is the angle of depression from the top of the taller building to the top of the smaller building? Round to one decimal place.

 4 For this diagram:

- a** use Pythagoras' theorem to find the value of x
b use trigonometry to find the value of y correct to two decimal places.

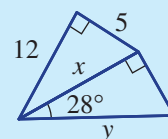

Multiple-choice questions

1 The length of the hypotenuse in this triangle is:

- A 11 cm B 13 cm C 14.8 cm
D 169 cm E $\frac{1}{\sqrt{119}}$ cm

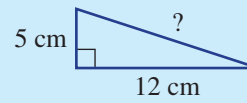

2 The value of x in the triangle shown is:

- A 3.9 B $\sqrt{113}$ C $\sqrt{57}$ D $\sqrt{15}$ E 2.7

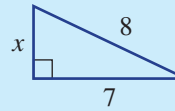

3 The value of x in the triangle shown is closest to:

- A 6.7 B 7.4 C 14.9
D 13.5 E 9.0

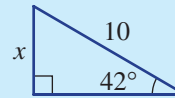

4 A correct ratio for this triangle is:

- A $\tan \theta = \frac{x}{y}$ B $\cos \theta = \frac{y}{z}$ C $\tan \theta = \frac{y}{x}$
D $\sin \theta = \frac{y}{x}$ E $\cos \theta = \frac{x}{y}$

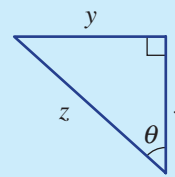

5 A 5-metre plank of wood is leaning up against a side of a building as shown. If the wood touches the ground 3 m from the base of the building, the angle the wood makes with the building is closest to:

- A 36.9° B 59° C 53.1° D 31° E 41.4°

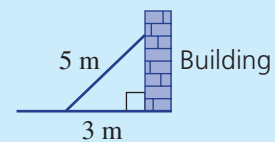

Extended-response questions



A skateboard ramp is constructed as shown.

- a Calculate the distance d metres up the ramp correct to two decimal places. Use Pythagoras' theorem.
b What is the angle of elevation (θ) between the ramp and the ground correct to one decimal place?
c If the skateboarder rides from one corner of the ramp diagonally to the other corner, what distance would be travelled? Round to one decimal place.

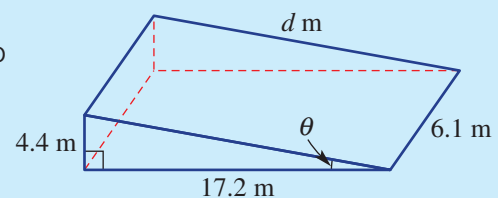

Linear relations

Short-answer questions

1 Sketch the following linear graphs labelling x - and y -intercepts.

a $y = 2x - 6$

b $3x + 4y = 24$

c $y = 4x$

2 Find the gradient of each of the following.

a The line passing through the points $(-1, 2)$ and $(2, 4)$

b The line passing through the points $(-2, 5)$ and $(1, -4)$

c The line with equation $y = -2x + 5$

d The line with equation $-4x + 3y = 9$



3 Give the equation of the following lines in gradient–intercept form.

a The line with the given graph

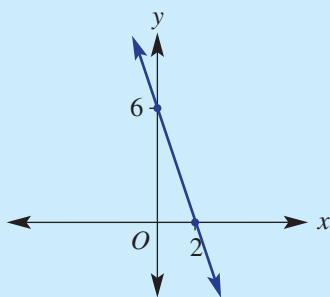

b The line with gradient 3 and passing through the point $(2, 5)$

4 Complete the table of values below for the rule $y = x^2 + 3$ and plot its graph.

x	-2	-1	0	1	2
y					

Multiple-choice questions

1 The x - and y -intercepts respectively for the graph shown are at:

A $(-2, 4)$ and $(4, -2)$

B $(0, 4)$ and $(-2, 0)$

C $(-2, 0)$ and $(0, 4)$

D $(4, 0)$ and $(0, -2)$

E $(2, 0)$ and $(0, -4)$

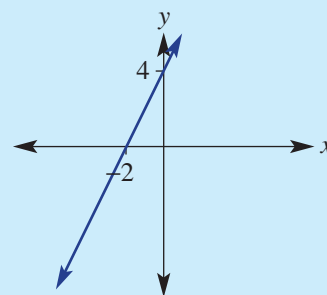

2 The graph shown has equation:

A $y = 3x$

B $y = 3$

C $y = x + 3$

D $x = 3$

E $x + y = 3$

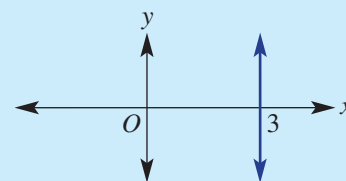

3 The line passing through the points $(-3, -1)$ and $(1, 1)$ has gradient:

- A $\frac{1}{2}$ B -3 C 1 D 2 E -2



4 If the point $(-1, 3)$ is on the line $y = 2x + c$, the value of c is:

- A 1 B 5 C -7 D -5 E -1



5 The midpoint and length to one decimal place of the line segment joining the points $(-2, 1)$ and $(4, 6)$ are:

- A $(1, 3.5)$ and 7.8 B $(3, 5)$ and 5.4 C $(3, 3.5)$ and 6.1
D $(1, 3.5)$ and 3.3 E $(3, 3.5)$ and 3.6

Extended-response questions



Doug works as a labourer. He is digging a trench and has 180 kg of soil to remove. He has taken 3 hours to remove 36 kg.

- What is the rate at which he is removing the soil?
- If he maintains this rate, write a rule for the amount of soil, S kg, remaining after t hours.
- Draw a graph of your rule.
- How long will it take to remove all of the soil?
- Doug is paid \$40 for the job plus \$25 per hour worked.
 - Write a rule for his pay P dollars for working h hours.
 - How much will he be paid to remove all the soil?



Chapter 6

Measurement

Essential mathematics: why measurement skills are important

It's hard to overstate the importance of measurement skills, which are found in almost every type of practical work, including the work of:

- bakers, boilermakers, bricklayers, builders, carpenters, carpet layers, concreters, cooks;
- engineers, farmers, forestry workers, furniture makers, glaziers, graphic artists;
- hairdressers, house painters, landscapers, machinists, mechanics, pipelayers, painters;
- plumbers, plasterers, sheet-metal workers, surveyors, tailors, tilers and welders.

To give just a few examples:

- Sports courts and athletics tracks have official dimensions applied around the world. An Olympic running track has 84.39 m for the straight sections and a 36.50 m radius for each semicircle.
- The rectangular prism that totally changed global cargo transport is the shipping container. The largest container ship (in 2019) can carry 23 756 containers.
- Cylinder surface area and volume calculations include for food cans, water storage tanks, fuel and milk tankers, and fuel station tanks (buried underground).



In this chapter

- 6A Length and perimeter
(Consolidating)
- 6B Circumference of a circle
(Consolidating)
- 6C Area (Consolidating)
- 6D Area of a circle
(Consolidating)
- 6E Composite shapes
- 6F Surface area of prisms
- 6G Surface area of a cylinder
- 6H Volume
- 6I Volume of a cylinder

Australian Curriculum

MEASUREMENT AND GEOMETRY

Using units of measurement

Calculate areas of composite shapes (ACMMG216)

Calculate the surface area and volume of cylinders and solve related problems (ACMMG217)

Solve problems involving the surface area and volume of right prisms (ACMMG218)

© Australian Curriculum, Assessment and Reporting Authority (ACARA)

Online resources

A host of additional online resources is included as part of your Interactive Textbook, including HOTmaths content, video demonstrations of all worked examples, auto-marked quizzes and much more.

1 Count the number of squares in these shapes to find the area.

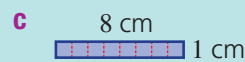
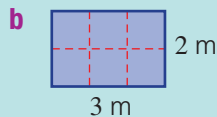
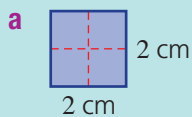

2 Find the distance (perimeter) around the shapes in Question 1.

3 Count the number of cubes in these solids to find the volume.

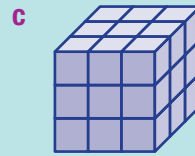
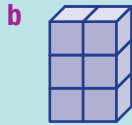

4 a Name the solid shown at right.

b What is the name of the shape (shaded) on top of the solid?

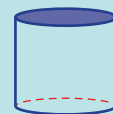

5 Calculate the following by moving the decimal point right (for \times) or left (for \div).

a 2.3×10

b 0.048×1000

c $270 \div 100$

d $52134 \div 10\,000$

e $0.0005 \times 100\,000$

f $72\,160 \div 1000$

6 Estimate the area (number of squares) in this oval.

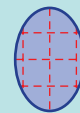

7 Convert the following to the units shown in the brackets. Remember: 1 km = 1000 m, 1 m = 100 cm and 1 cm = 10 mm.

a 3 cm (mm)

b 20 m (cm)

c 1.6 km (m)

d 23 mm (cm)

e 3167 m (km)

f 72 cm (m)

g 20 000 m (km)

h 0.03 km (m)

i 75.6 m (km)

8 Find the area of these basic shapes using the given formulas.

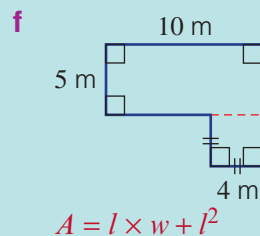
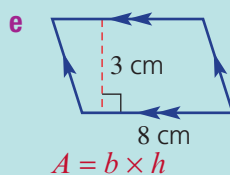
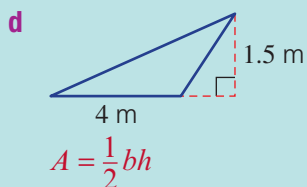
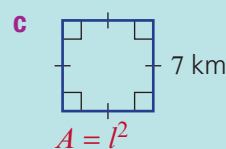
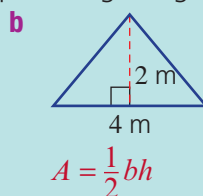
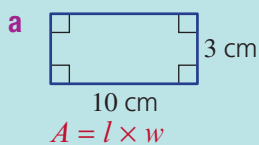

9 Find the circumference ($C = 2\pi r$) and area ($A = \pi r^2$) of this circle, rounding to two decimal places.

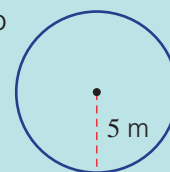

6A Length and perimeter

CONSOLIDATING

Learning intentions

- To review the metric units of length
- To be able to convert between metric units of length
- To be able to find the perimeter of a simple closed shape

Key vocabulary: perimeter, length

Measurement is the branch of mathematics that includes the consideration of length, area and volume. This includes units of measurement, perimeter, circumference, surface area, composite shapes and capacity.

We use measurement when we design buildings, water our gardens, control satellites, fill our cars with petrol or participate in school athletics days.



Lesson starter: Not enough information?

All the angles at each vertex in this shape are 90° and the two given lengths are 10 cm and 13 cm.

- Is there enough information to find the perimeter of the shape?
- If there is enough information, find the perimeter and discuss your method.

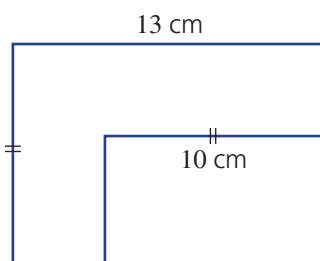

Key ideas

- Units of length in the metric system include kilometre (km), metre (m), centimetre (cm) and millimetre (mm)
- To convert between metric units of length, multiply or divide by the appropriate power of 10.

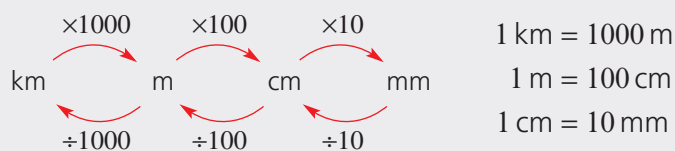

- **Perimeter** is the distance around the outside of a closed shape.
 - Sides with the same markings are of equal length

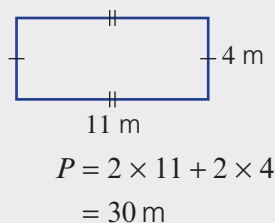
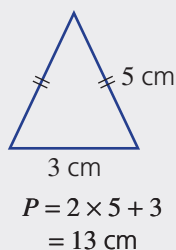

Exercise 6A

Understanding

1-3

3

- 1 Fill in the gaps on this flow chart.

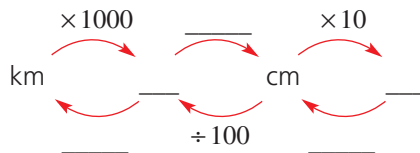

- 2 Choose from the words: *multiply*, *divide*, *add* or *subtract* to complete this sentence.

To find the perimeter of a shape you would _____ all the side lengths.

- 3 Write down the value of x in these diagrams.

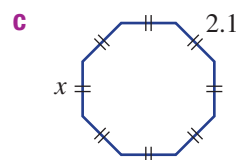
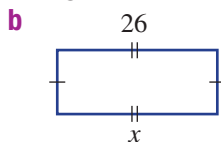
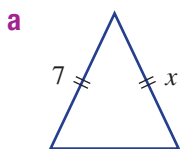

Fluency

4(½), 5, 6(½)

4(½), 6(½), 7



Example 1 Converting units of length

Convert to the units shown in the brackets.

a 5.41 cm (mm)

b 3200 m (km)

Solution

Explanation

a $5.41 \text{ cm} = 5.41 \times 10 \text{ mm}$
 $= 54.1 \text{ mm}$

1 cm = 10 mm and you are moving to a smaller unit, so multiply.
 Move the decimal point one place to the right.

b $3200 \text{ m} = 3200 \div 1000 \text{ km}$
 $= 3.2 \text{ km}$

1 km = 1000 m and you are moving to a larger unit, so divide.
 Move the decimal point three places to the left.

Now you try

Convert to the units shown in the brackets.

a 2.4 m (cm)

b 420 mm (cm)

- 4 Convert the following length measurements into the units given in the brackets.

a 5 cm (mm)

b 41 cm (mm)

c 2.8 m (cm)

d 0.4 m (cm)

e 4.6 km (m)

f 0.9 km (m)

g 521 mm (cm)

h 36 mm (cm)

i 240 cm (m)

j 83.7 cm (m)

k 7000 m (km)

l 2170 m (km)

Hint: Multiply when changing to a smaller unit and divide when changing to a larger unit.



- 5 A steel beam is 8.25 m long and 22.5 mm wide. Write down the length and the width of the beam in centimetres.



Example 2 Finding perimeters of simple shapes

Find the perimeter of each of the following shapes.

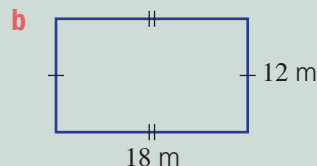
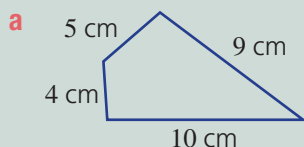

Solution

- a** $P = 10 + 9 + 5 + 4$
 $= 28 \text{ cm}$
- b** $P = 2 \times 12 + 2 \times 18$
 $= 24 + 36$
 $= 60 \text{ m}$

Explanation

To find the perimeter, add all the side lengths together.

Two lengths of 12 m and two lengths of 18 m.

Now you try

Find the perimeter of each of the following shapes.

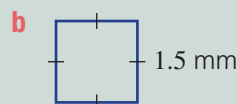
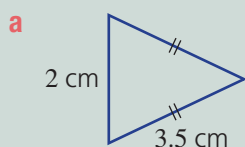

- 6 Find the perimeter of each of the following shapes.

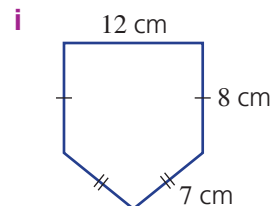
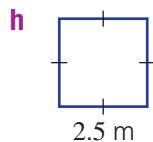
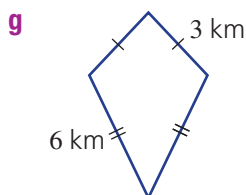
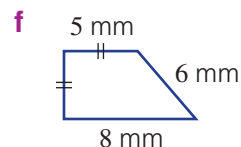
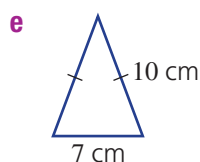
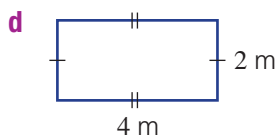
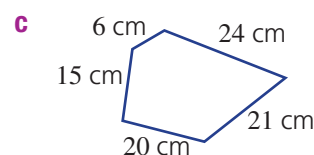
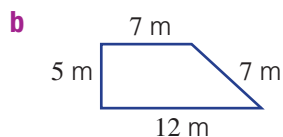
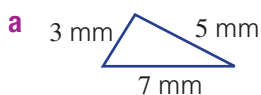

- 7 Find the unknown side length in these shapes with the given perimeters.

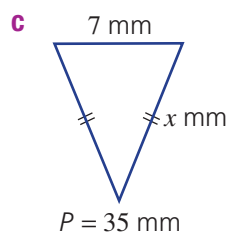
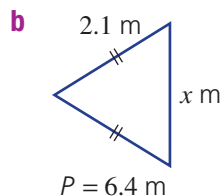
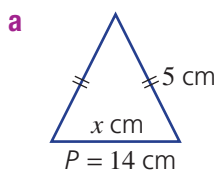

Hint: Use trial and error, if you like, to find the value of x .



Problem-solving and reasoning

8–10

9–12

8 Write down the values of the pronumerals in these shapes. All angles are 90° .

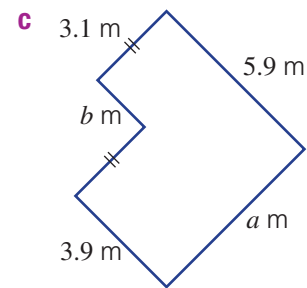
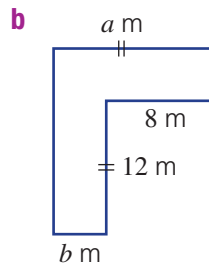
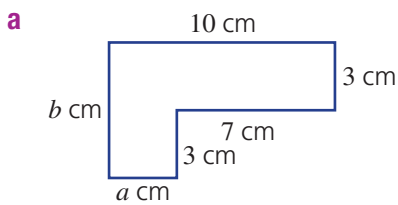

 **Example 3 Finding the perimeter of composite shapes**

Find the perimeter of this composite shape.

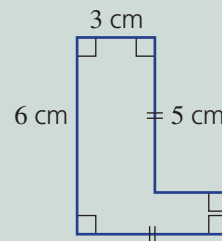
**Solution**

$$\begin{aligned} \text{Perimeter} &= (2 \times 5) + 6 + 3 + 2 + 1 \\ &= 22 \text{ cm} \end{aligned}$$

Explanation

Missing sides are:
 $5 \text{ cm} - 3 \text{ cm} = 2 \text{ cm}$
 $6 \text{ cm} - 5 \text{ cm} = 1 \text{ cm}$
 Alternatively:
 $2 \times 6 + 2 \times 5 = 22 \text{ cm}$

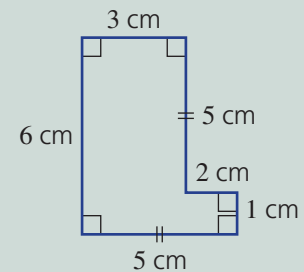
**Now you try**

Find the perimeter of this composite shape.

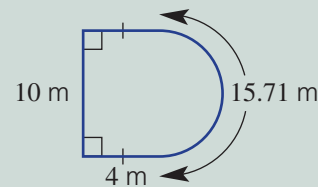

9 Find the perimeter of each of the following composite shapes.

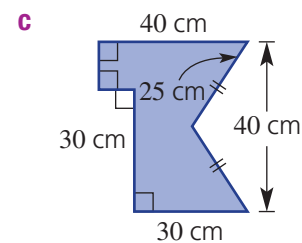
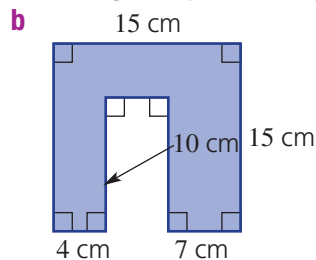
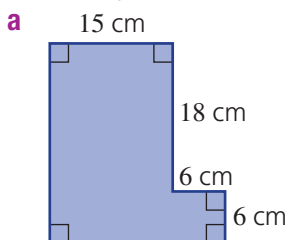

Hint: First label all the missing side lengths and then find the perimeter.



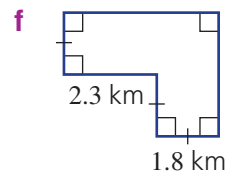
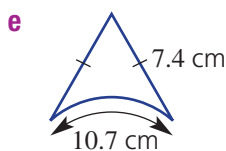
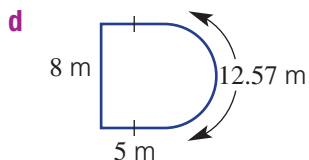

- 10** A lion cage is made up of five straight fence sections. Three sections are 20 m in length and the other two sections are 15.5 m and 32.5 m. Find the perimeter of the cage.



- 11** Convert the following measurements into the units given in the brackets.

- a** 8 m (mm) **b** 110 000 mm (m)
c 0.00001 km (cm) **d** 0.02 m (mm)
e 28 400 cm (km) **f** 62 743 000 mm (km)

Hint: In part **a**, first convert to cm and then to mm.



- 12** Find the perimeter of these shapes. All angles are right angles.

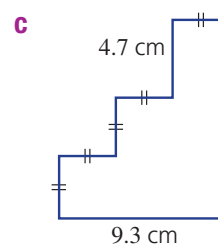
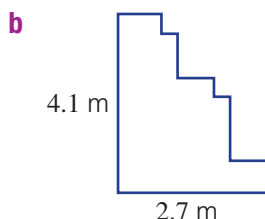
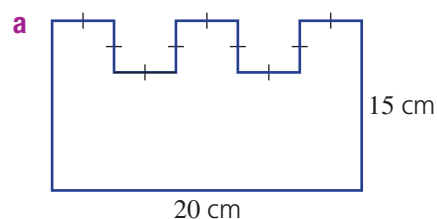

Picture framing

13, 14

- 13** A photo 12 cm wide and 20 cm long is surrounded with a picture frame 3 cm thick. Find the outside perimeter of the framed picture.
- 14** A square picture of side length 20 cm is inside a frame of width x cm.

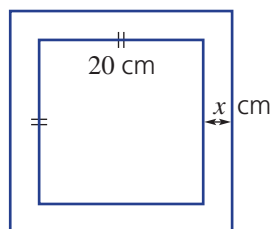

- a** Find the perimeter of the framed picture if:
i $x = 2$ **ii** $x = 3$ **iii** $x = 5$
- b** Write a rule for the perimeter, P , of the framed picture in terms of x .
- c** Use your rule to find the perimeter if $x = 3.7$.

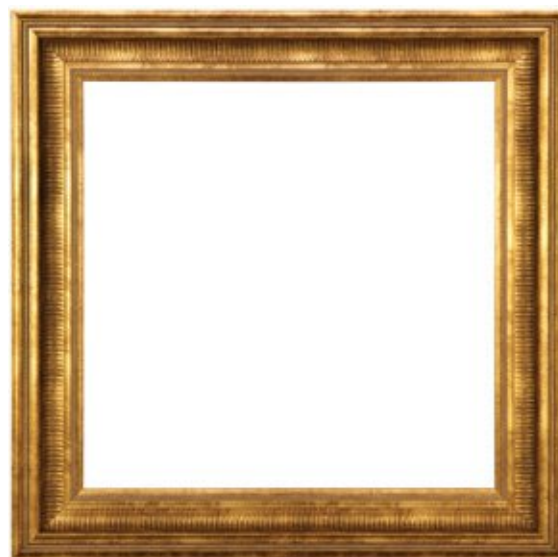

6B Circumference of a circle

CONSOLIDATING

Learning intentions

- To know the formula for the circumference of a circle
- To be able to find the circumference of a circle
- To be able to find the perimeter of semicircles and quadrants

Key vocabulary: circumference, pi, radius, diameter, circle, semicircle, quadrant

For thousands of years, mathematicians have known about a special number that links a circle's diameter to its circumference.

The Egyptians, Babylonians and ancient Indians knew about this special number, and thought its value was about 3.15.

Today we call this number pi (π) and know it to be 3.14159, correct to five decimal places.

An exact value of pi cannot be written down as a decimal, as it has an infinite number of decimal places with no pattern.

→ Lesson starter: Working with string

Use a pair of compasses, a ruler and a piece of string for this activity.

The table below contains some approximate circle measurements.

Circumference (C)	Diameter (d)	$C \div d$
18.8	6.0	
12.6	4.0	
...	...	
...	...	



- Copy the table, leaving two blank rows.
- Use your compasses to draw a circle, then measure its diameter using a ruler and its circumference using your string (try to be as accurate as possible). Add this information to the table.
- Do this again, with a different-sized circle.
- Calculate $C \div d$ in the third column for each of the four circles. What do you notice?
- What does this say about how to calculate the circumference of a circle if you know the diameter?

Key ideas

■ Features of a circle:

- **Diameter** (d) is the distance across the centre.
- **Radius** (r) is the distance from the centre to the circumference.
- $d = 2r$
- **Circumference** of a circle (the distance around the outside) is given by $C = 2\pi r$ or $C = \pi d$.
- Use $\frac{22}{7}$ or 3.14 to approximate π (**pi**), or use technology for more precise calculations.

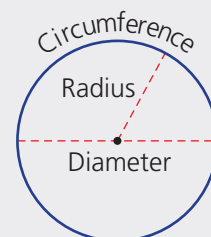

■ Special circle sectors:

- a half circle is called a **semicircle**
- a quarter circle is called a **quadrant**



Exercise 6B

Understanding

1–4

4

- 1 Name the features of a circle labelled on the circle shown.

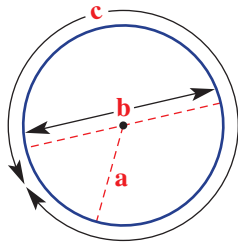

- 2 **a** What is the radius of a circle if its diameter is 5.6 cm?
b What is the diameter of a circle if its radius is 48 mm?
- 3 Write down the rule for the circumference of a circle using:
a r , the radius **b** d , the diameter
- 4 Determine the **fraction** of a circle shown in these sectors. Write the fraction in simplest form.

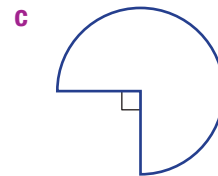
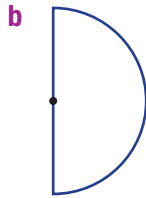
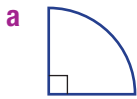

Fluency

5–7(½)

5–7(½)



Example 4 Finding the circumference of a circle

Find the circumference of this circle correct to two decimal places.

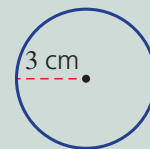

Solution

$$\begin{aligned} C &= 2\pi r \\ &= 2 \times \pi \times 3 \\ &= 6\pi \\ &= 18.85 \text{ cm (to 2 d.p.)} \end{aligned}$$

Explanation

Use the formula $C = 2\pi r$ or $C = \pi d$ and substitute $r = 3$ (or $d = 6$).

6π would be the exact answer and 18.85 is the rounded answer.

Now you try

Find the circumference of this circle correct to two decimal places.



6B



- 5 Find the circumference of these circles correct to two decimal places. Use a calculator for the value of π .

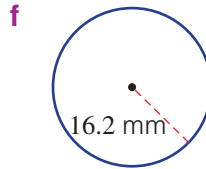
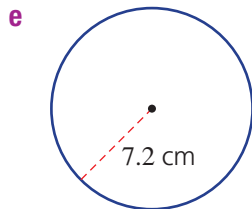
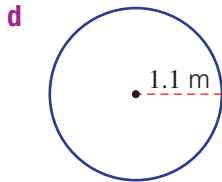
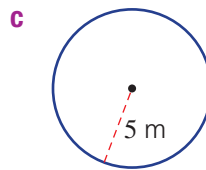
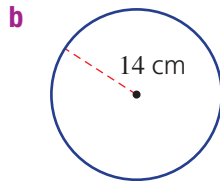
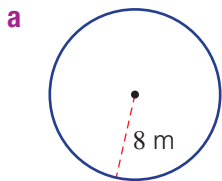

Hint: Write the rule $C = 2\pi r$, then substitute the radius length.



Example 5 Finding circumference using the diameter

Find the circumference of this circle, correct to two decimal places.

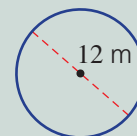

Solution

$$\begin{aligned} C &= \pi d \\ &= \pi \times 12 \\ &= 37.70 \text{ m (to 2 d.p.)} \end{aligned}$$

Explanation

Write the formula. $C = \pi d$ is preferred since d is given. Substitute $d = 12$ and multiply by π . Use a calculator and round. Note: 37.6991 rounds to 37.70 for two decimal places.

Now you try

Find the circumference of this circle, correct to two decimal places.

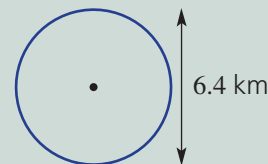

- 6 Find the circumference of these circles correct to two decimal places.

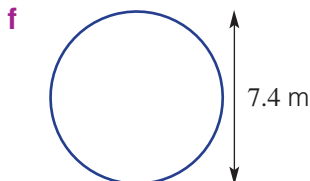
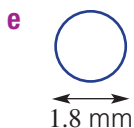
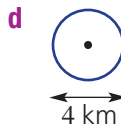
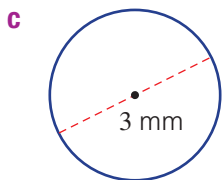
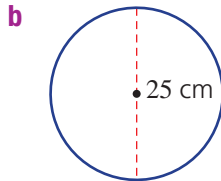
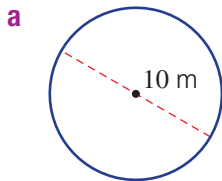

Hint: Write the rule $C = \pi d$ and then substitute the diameter length.



- 7 Find the circumference of these circles without a calculator using the given approximation of π .

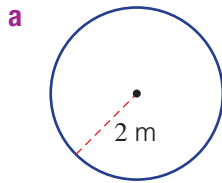

$$\pi = 3.14$$

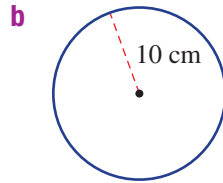

$$\pi = 3.14$$

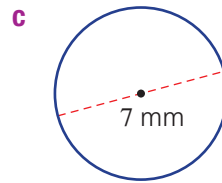

$$\pi = \frac{22}{7}$$

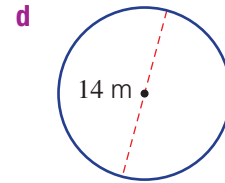

$$\pi = \frac{22}{7}$$

Problem-solving and reasoning

8(½), 9, 10

8, 10, 11

Example 6 Working with a semicircle or quadrant

Find the perimeter of this semicircle correct to two decimal places.

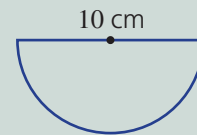

Solution

$$\begin{aligned} P &= \frac{1}{2} \times \pi d + 10 \\ &= \frac{1}{2} \times \pi \times 10 + 10 \\ &= 25.71 \text{ cm (to 2 d.p.)} \end{aligned}$$

Explanation

The perimeter consists of half the circumference of a circle (with diameter 10 cm) plus the 10 cm diameter across the top.

Now you try

Find the perimeter of this quadrant correct to two decimal places.

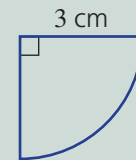

- 8 Find the perimeter of these sectors correct to two decimal places.

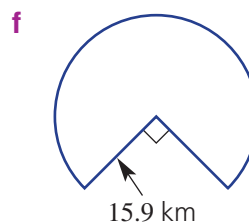
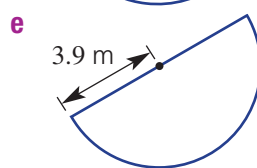
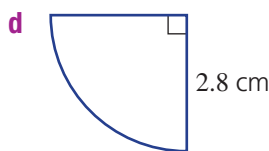
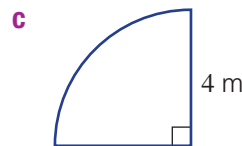
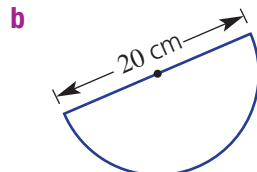
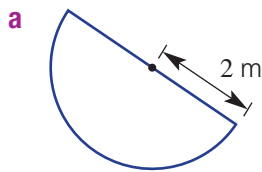

Hint: Decide what fraction of the circumference you want and don't forget to add the straight sides.



- 9 Find the distance around the outside of a circular pool of radius 4.5 m, correct to two decimal places.



6B



- 10 Find the length of string required to surround the circular trunk of a tree that has a diameter of 1.3 m, correct to one decimal place.
- 11 Find the perimeter of these shapes, correct to two decimal places.

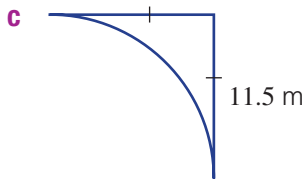
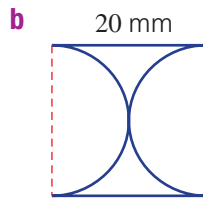
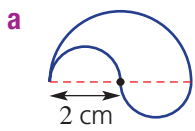

Hint: Two semicircles of the same size make a full circle. When finding the perimeter, imagine you are walking around the edge of the shape.



The rolling wheel

—

12



- 12 A wheel of radius 30 cm is rolled in a straight line.
- a Find the circumference of the wheel correct to two decimal places.
- b How far, correct to two decimal places, has the wheel rolled after completing:
- i 2 rotations? ii 10.5 rotations?
- c Can you find how many rotations would be required to cover at least 1 km in length? Round to the nearest whole number.

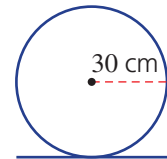

6C Area

CONSOLIDATING

Learning intentions

- To know the formulas for the area of common shapes
- To be able to convert metric units for area
- To be able to find the area of common shapes

Key vocabulary: area, triangle, square, rectangle, rhombus, parallelogram, trapezium, kite, perpendicular

For many common shapes, such as the parallelogram and trapezium, the rules for finding their area can be found using simple rectangles and triangles.

The parallelogram, for example, can be seen as a 'pushed over' rectangle. Its area can be calculated in the same way as a rectangle.

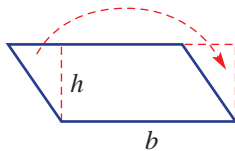

$$\text{So } A = l \times w = b \times h$$



→ Lesson starter: Build the formulas

From the introduction, you can see how the rule for the area of a parallelogram is given by $A = b \times h$.

Use the given diagrams to explain the rules for the areas of each shape.

- Triangle: $A = \frac{1}{2} b \times h$

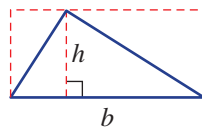

- Trapezium: $A = \frac{1}{2} (a + b)h$

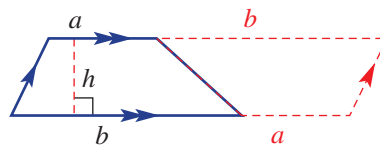

- Rhombus: $A = \frac{1}{2} xy$

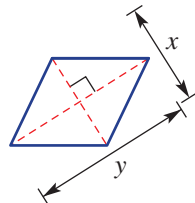

Key ideas

- Conversion of area units

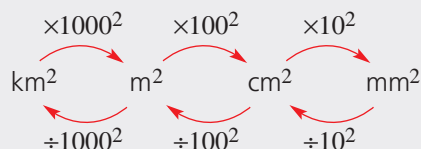

$$10^2 = 10 \times 10 = 100$$

$$100^2 = 100 \times 100 = 10\,000$$

$$1000^2 = 1000 \times 1000 = 1\,000\,000$$

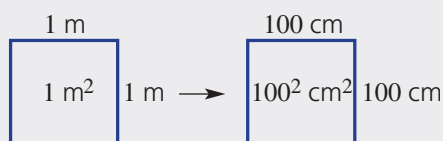

6C

- The **area** of a two-dimensional shape is a measure of the space enclosed within its boundaries.
 - The 'height' (h) in the formulas for the area of a triangle, parallelogram and trapezium must be **perpendicular** (at 90°) to the base.

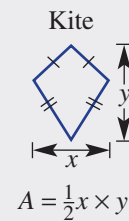
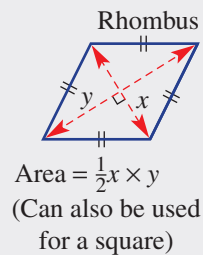
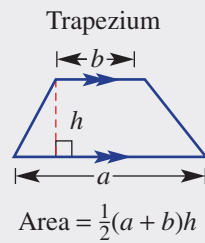
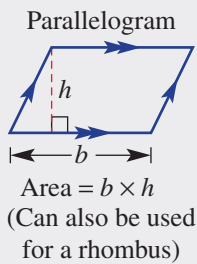
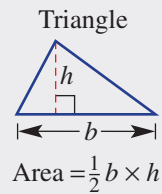
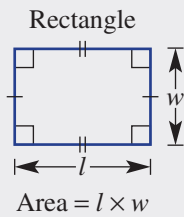
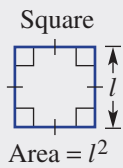

Exercise 6C

Understanding

1–3

3

- 1 Write the missing number.

a $1 \text{ cm}^2 = 10^2 \text{ mm}^2 = \underline{\hspace{2cm}} \text{ mm}^2$

b $1 \text{ m}^2 = 100^2 \text{ cm}^2 = \underline{\hspace{2cm}} \text{ cm}^2$

c $1 \text{ km}^2 = 1000^2 \text{ m}^2 = \underline{\hspace{2cm}} \text{ m}^2$

- 2 Count the number of squares to find the area of these shapes. Each square in each shape represents one square unit.

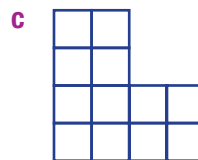
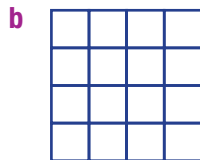
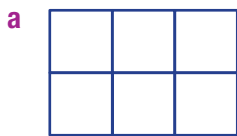

Hint: For parts d and e, note that each triangle is half of a rectangle.

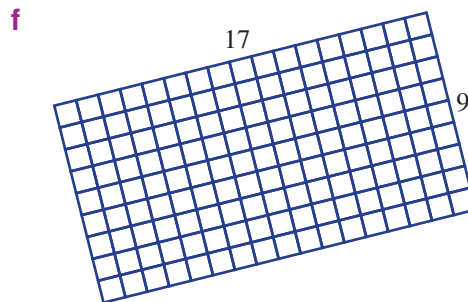
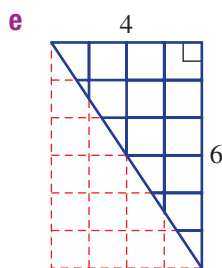
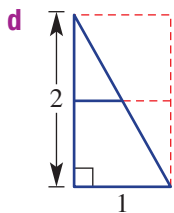

- 3 Name the shape that usually has the given area formula.

a $A = lw$

b $A = \frac{1}{2}xy$ (2 shapes)

c $A = \frac{1}{2}bh$

d $A = \frac{1}{2}(a + b)h$

e $A = bh$

f $A = l^2$

Fluency

4(½), 5, 6

4–6(½)



Example 7 Converting units of area

Convert the following area measurements into the units given in the brackets.

a 859 mm^2 (cm^2)

b 2.37 m^2 (cm^2)

Solution

Explanation

a $859 \text{ mm}^2 = 859 \div 10^2 \text{ cm}^2$
 $= 8.59 \text{ cm}^2$

cm^2 mm^2 $859.$
 $\div 10^2 = 100$

b $2.37 \text{ m}^2 = 2.37 \times 100^2 \text{ cm}^2$
 $= 23\,700 \text{ cm}^2$

$\times 100^2 = 10\,000$
 m^2 cm^2 2.3700

Now you try

Convert the following area measurements into the units given in the brackets.

a $32\,000 \text{ cm}^2$ (m^2)

b 0.4 km^2 (m^2)

4 Convert the following area measurements into the units given in the brackets.

a 2 cm^2 (mm^2)

b 0.4 cm^2 (mm^2)

c 500 mm^2 (cm^2)

d 310 mm^2 (cm^2)

e 2.1 m^2 (cm^2)

f 0.2 m^2 (cm^2)

g $210\,000 \text{ cm}^2$ (m^2)

h 3700 cm^2 (m^2)

i 0.001 km^2 (m^2)

j 4.3 km^2 (m^2)

k $3\,200\,000 \text{ m}^2$ (km^2)

l $39\,400 \text{ m}^2$ (km^2)

Hint: Multiply or divide by:
 $10^2 = 100$
 $100^2 = 10\,000$
 or $1000^2 = 1\,000\,000$



Example 8 Finding areas of rectangles, triangles and parallelograms

Find the area of each of the following plane figures.

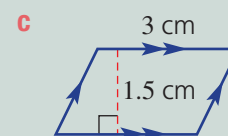
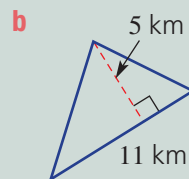
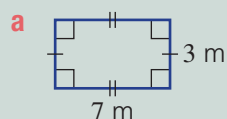

Solution

Explanation

a Area = $l \times w$
 $= 7 \times 3$
 $= 21 \text{ m}^2$

Use the area formula for a rectangle. Substitute $l = 7$ and $w = 3$. Include the correct units.

b Area = $\frac{1}{2} \times b \times h$
 $= \frac{1}{2} \times 11 \times 5$
 $= 27.5 \text{ km}^2$

Use the area formula for a triangle.

Substitute $b = 11$ and $h = 5$, where h is the height perpendicular (at 90°) to the base.

c Area = $b \times h$
 $= 3 \times 1.5$
 $= 4.5 \text{ cm}^2$

Use the area formula for a parallelogram.

Multiply the base length by the perpendicular height.

6C

Now you try

Find the area of each of the following plane figures.

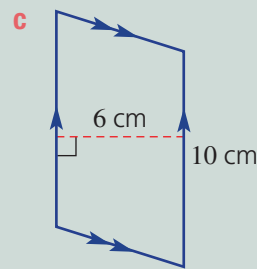
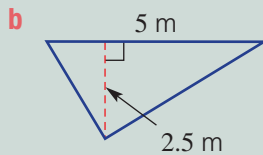
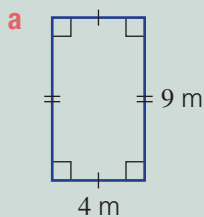

5 Find the area of each of the following plane figures.

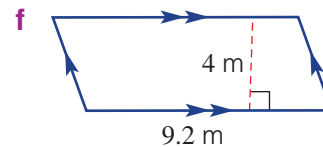
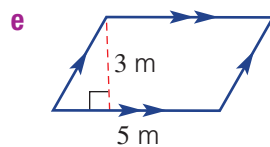
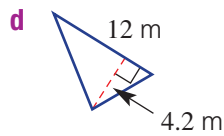
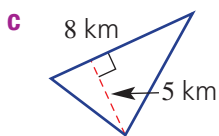
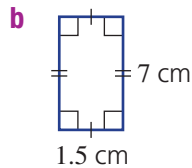
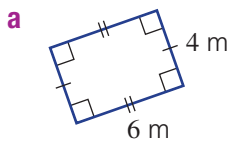

Hint: Choose from

$$A = l \times w,$$

$$A = \frac{1}{2} b \times h$$

$$\text{or } A = b \times h$$



Example 9 Finding areas of rhombuses and trapeziums

Find the area of each of the following plane figures.

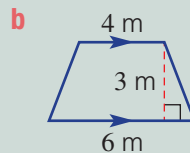
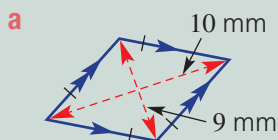

Solution

$$\begin{aligned} \text{a Area} &= \frac{1}{2} \times x \times y \\ &= \frac{1}{2} \times 10 \times 9 \\ &= 45 \text{ mm}^2 \end{aligned}$$

$$\begin{aligned} \text{b Area} &= \frac{1}{2} (a + b) \times h \\ &= \frac{1}{2} (4 + 6) \times 3 \\ &= 15 \text{ m}^2 \end{aligned}$$

Explanation

Use the area formula for a rhombus.
 x and y are the lengths of the diagonals.
 $\frac{1}{2} \times 10 \times 9 = 5 \times 9 = 45$

Use the area formula for a trapezium.

Substitute $a = 4$, $b = 6$ and $h = 3$.

Include the correct units.

Now you try

Find the area of each of the following plane figures.

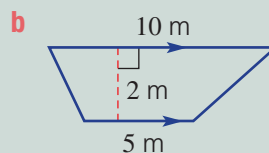
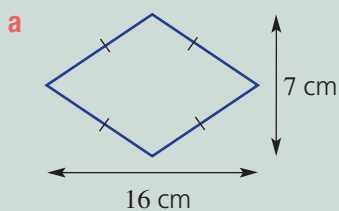



6 Find the area of each of the following plane figures.

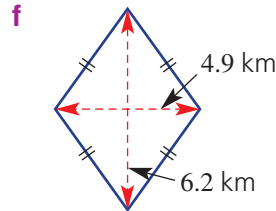
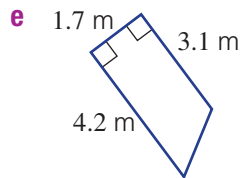
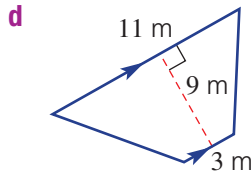
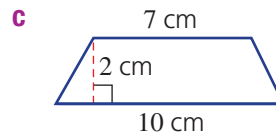
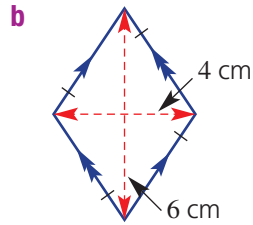
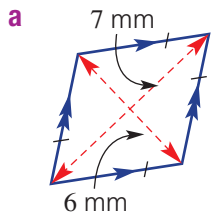

Hint: Choose from
 $A = \frac{1}{2}x \times y$ or
 $A = \frac{1}{2}(a+b) \times h$



Problem-solving and reasoning

7, 8, 9(½)

8–11

- 7 A piece of land has an area of one-half a square kilometre (0.5 km^2). How many square metres (m^2) is this?
- 8 A rectangular park covers an area of $175\,000 \text{ m}^2$. Give the area of the park in km^2 .



9 Find the area of each of the following mixed-plane figures.

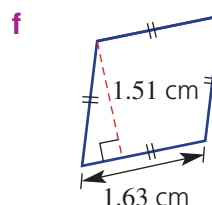
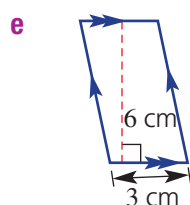
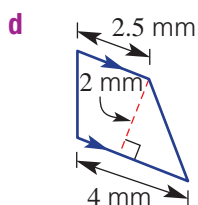
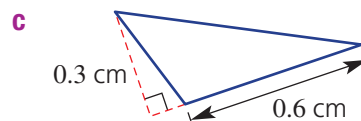
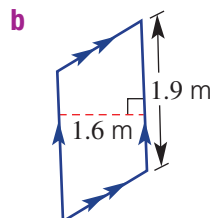
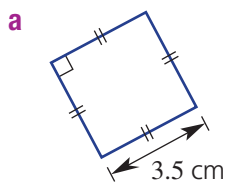

Hint: Choose from
 $A = l^2$, $A = b \times h$,
 $A = \frac{1}{2}b \times h$ or
 $A = \frac{1}{2}(a+b)h$



- 10 An old picture frame that was once square now leans to one side to form a rhombus. If the distances between pairs of opposite corners are 85 cm and 1.2 m, find the area inside the frame in m^2 .
- 11 Convert the following measurements into the units given in the brackets.
- a** 1.5 km^2 (cm^2) **b** 0.000005 m^2 (mm^2) **c** $75\,000 \text{ mm}^2$ (m^2)

6C



Windows

—

12

-  **12** Six square windows of side length 2 m are placed into a 12 m wide by 8.5 m rectangular high wall, as shown. The windows are positioned so that the vertical spacing between the windows and the wall edges are equal. The horizontal spacings are also equal.

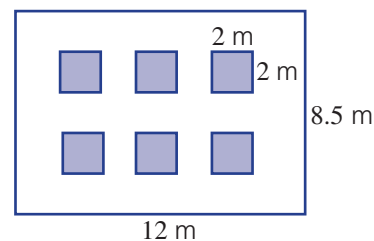

- a**
- Find the horizontal distance between the windows.
 - Find the vertical distance between the windows.
- b** Find the area of the wall, not including the window spaces.
- c** If the wall included 3 rows of 4 windows (instead of 2 rows of 3), would it be possible to space all the windows so that the horizontal and vertical spacings are the same? (Horizontal doesn't have to be the same as vertical.)



Using a calculator 6C: Measurement formulas

This activity can be found in the More Resources section of the Interactive Textbook in the form of a printable PDF.

6D Area of a circle

CONSOLIDATING

Learning intentions

- To know the formula for the area of a circle
- To be able to find the area of circles
- To be able to find the area of semicircles and quadrants

Key vocabulary: circle, sector, radius, diameter, semicircle, quadrant, pi

We know that the circumference of a circle is connected to the diameter by the special number pi (π).

Similarly, the area of a circle is also connected to pi. This time it is the product of pi and the square of the radius that gives the area; so, $A = \pi r^2$.

→ Lesson starter: How does a circle become a rectangle?

Consider a circle cut into small sectors, as shown, then rearranged to form a rectangular-style shape.

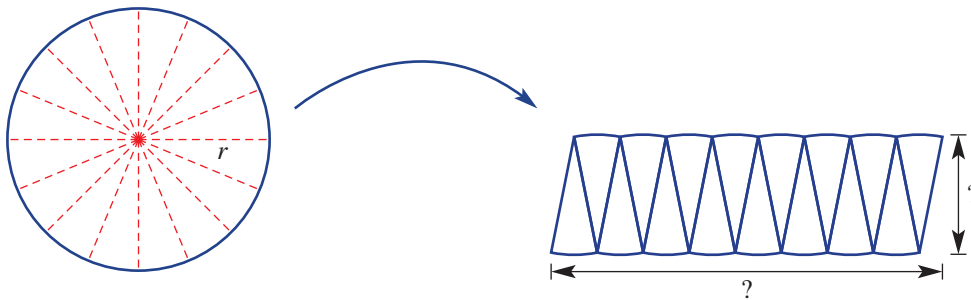

- Compared to the circle, what is the height of the rectangle close to?
- Compared to the circle, what is the length of the rectangle close to?
- What does this say about the area of the rectangle and hence the area of a circle?
- What could be done with the cutting up of sectors so that the rectangular arrangement is closer to a true rectangle?

Key ideas

- The area of a circle is given by $A = \pi r^2$.
 - If the diameter is given, halve it to find the radius.
 - $\pi r^2 = \pi \times r \times r$

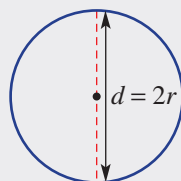
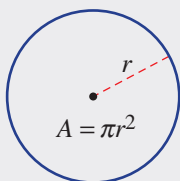

- For the area of a **semicircle** or **quadrant**, use the appropriate fraction.

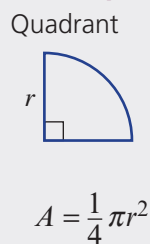
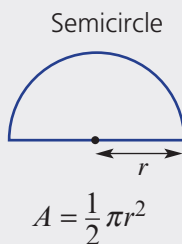

Exercise 6D

Understanding

1-3

3

1 What is the radius of these circles?

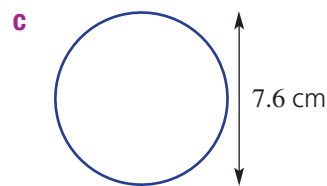
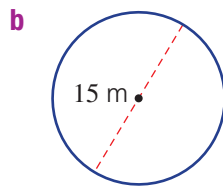
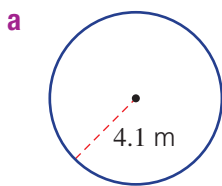

2 Which is the correct formula for the area of a circle?

A $A = \pi d^2$

B $A = \frac{1}{2} \pi r^2$

C $A = \pi r^2$

D $A = (\pi r)^2$

3 What fraction of a full circle is shown by these sectors?

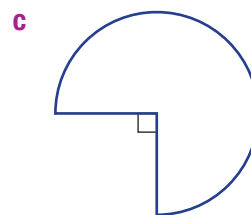
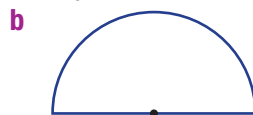

Fluency

4(1/2), 5

4(1/2), 5, 6



Example 10 Finding areas of circles

Find the area of this circle correct to two decimal places.

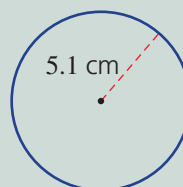

Solution

$$\begin{aligned} A &= \pi r^2 \\ &= \pi \times (5.1)^2 \\ &= 81.71 \text{ cm}^2 \text{ (to 2 d.p.)} \end{aligned}$$

Explanation

Write the rule and substitute $r = 5.1$.

81.7128 rounds to 81.71 since the third decimal place is 2.

Now you try

Find the area of this circle correct to two decimal places.

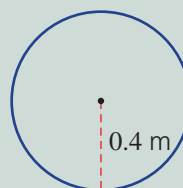



4 Find the area of these circles correct to two decimal places.

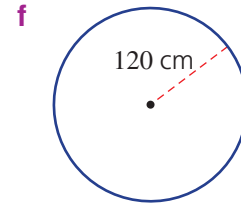
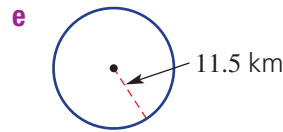
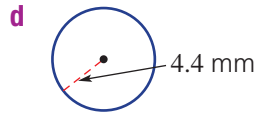
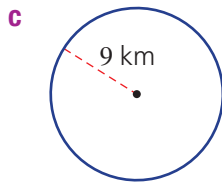
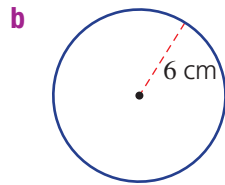
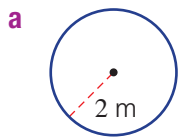

Hint: Substitute the radius into $A = \pi r^2$.



5 Find the area of these circles correct to two decimal places.

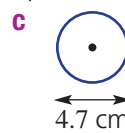
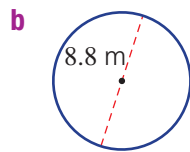
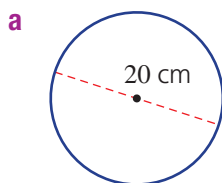

Hint: First work out the radius.



6 Find the area of these circles using the given value for pi (π). Round to two decimal places.

a $\pi = 3.14$

b $\pi = \frac{22}{7}$

c π (from calculator)

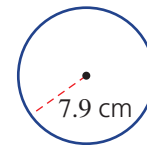

Problem-solving and reasoning

7–9

7, 9–11



Example 11 Finding the area of a quadrant or semicircle

Find the area of this quadrant correct to two decimal places.

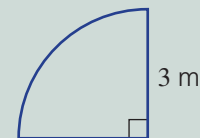

Solution

$$\begin{aligned} A &= \frac{1}{4} \times \pi r^2 \\ &= \frac{1}{4} \times \pi(3)^2 \\ &= 7.07 \text{ m}^2 \text{ (to 2 d.p.)} \end{aligned}$$

Explanation

A quadrant is one quarter of the area of a full circle.

Substitute $r = 3$ and evaluate.

Now you try

Find the area of this semicircle correct to two decimal places.

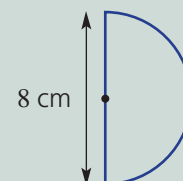

6D



7 Find the area of these sectors correct to two decimal places.

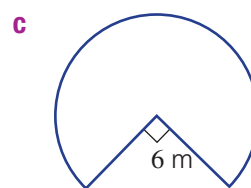
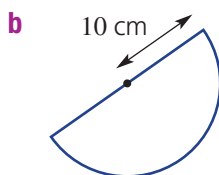

8 A pizza of radius 15 cm is divided into quarters. Find the area of each quarter correct to the nearest cm^2 .



9 A circular rug touches the edges of a square room of side length 4 m.

- a** What is the radius of the rug?
b Find the area of the rug correct to two decimal places.
c Find the area not covered by the rug correct to two decimal places.
d Find the percentage of the floor that is not covered by the rug, correct to one decimal place.

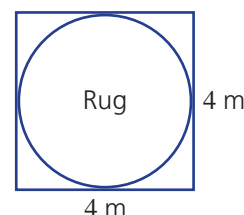

Hint:

$$\% \text{ non-rug area} = \frac{\text{non-rug area}}{\text{total area}} \times \frac{100}{1}$$



10 A pizza shop is considering increasing the diameter of its family pizza tray from 32 cm to 34 cm. Find the percentage increase in area, correct to two decimal places, from the 32 cm tray to the 34 cm tray.



11 You can rearrange $A = \pi r^2$ to give $r = \sqrt{\frac{A}{\pi}}$. Use this new rule to find the radius of a circle for these areas. Round to one decimal place where necessary.

a 10 cm^2

b 117.8 m^2

c $4\pi \text{ km}^2$



Tennis lights

—

12



12 A tennis court area is lit by 4 corner lights. The area close to each light is considered to be good (G) while the remaining area is lit satisfactorily (S). What percentage of the area is 'good'? Round to the nearest percent.

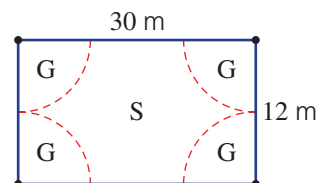

6E Composite shapes

Learning intentions

- To be able to recognise the basic shapes that make up a composite shape
- To be able to find the area of simple composite shapes

Key vocabulary: composite shape, area, perimeter

Composite shapes are made up of a number of simple shapes. You can find the perimeters and areas of composite shapes by first identifying the simple shapes and then using their perimeter and area formulas.

→ Lesson starter: A fraction of a circle plus a square

This diagram shows a fraction of a circle plus a square.

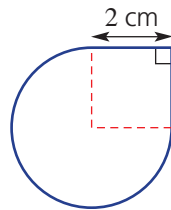

- How could you find the area and perimeter of the shape?
- See if you can write down a full solution for finding the area and perimeter of the shape.
- See if your teacher or another student can easily follow your solution.

Key ideas

- Composite shapes** are made up of more than one basic shape.
- Addition and/or subtraction can be used to find areas and perimeters of composite shapes.
 - Use addition
 - Use subtraction (for area)

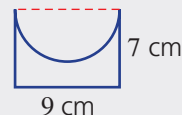
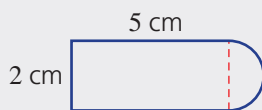

- The layout of the relevant mathematical working needs to make sense so that the reader of your work understands each step.

Exercise 6E

Understanding

1-3

3

- 1 Name the two different shapes that make up these composite shapes; e.g. square and semicircle.

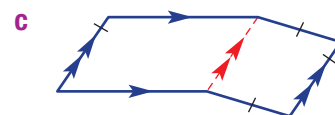
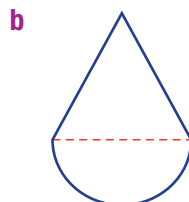

6E

2 What fraction of a circle would be considered when finding the perimeter of these shapes?

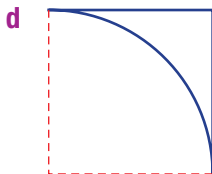
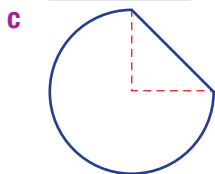
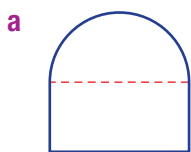

Hint: Choose from $\frac{1}{4}$, $\frac{1}{2}$ or $\frac{3}{4}$.



3 This composite shape includes a square and a quadrant ($\frac{1}{4}$ circle).

- a Find the area of the square.
 b Find the area of the quadrant correct to two decimal places.
 c Find the total area correct to two decimal places.

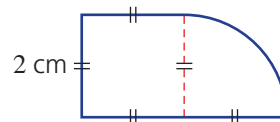

Fluency

4($\frac{1}{2}$), 54($\frac{1}{2}$), 5, 6($\frac{1}{2}$)

Example 12 Finding perimeters and areas of composite shapes

Find the perimeter and area of this composite shape, rounding answers to two decimal places.

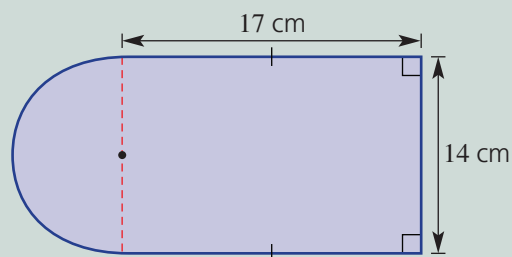

Solution

$$\begin{aligned} P &= 2 \times l + w + \frac{1}{2} \times \pi d \\ &= 2 \times 17 + 14 + \frac{1}{2} \times \pi \times 14 \\ &= 69.99 \text{ cm (to 2 d.p.)} \end{aligned}$$

$$\begin{aligned} \text{Area (rectangle)} &= l \times w \\ &= 17 \times 14 \\ &= 238 \text{ cm}^2 \end{aligned}$$

$$\begin{aligned} A \text{ (semicircle)} &= \frac{1}{2} \pi r^2 \\ &= \frac{1}{2} \times \pi \times 7^2 \\ &= 76.969 \dots \text{ cm}^2 \end{aligned}$$

$$\begin{aligned} \text{Total area} &= 238 + 76.969 \dots \\ &= 314.97 \text{ cm}^2 \text{ (to 2 d.p.)} \end{aligned}$$

Explanation

3 straight sides \square + semicircle arc \subset
 Recall that $C = \pi d$ (or $2\pi r$).
 Substitute $l = 17$, $w = 14$ and $d = 14$.
 Calculate and round to two decimal places.

The total area consists of a rectangle plus a semicircle.

$$\begin{array}{ccc} \begin{array}{c} \square \\ 17 \text{ cm} \\ 14 \text{ cm} \end{array} & + & \begin{array}{c} \text{semicircle} \\ 7 \text{ cm} \end{array} \\ A = l \times w & & A = \frac{1}{2} \pi r^2 \end{array}$$

Round to two decimal places.

Now you try

Find the perimeter and area of this composite shape.

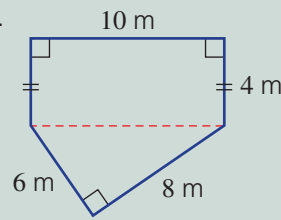

- 4 Find the perimeter and the area of each of these composite shapes, rounding answers to two decimal places where necessary.

Hint: First decide which two shapes you will be dealing with in each case.

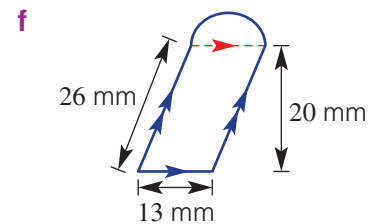
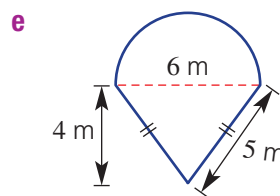
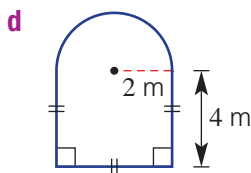
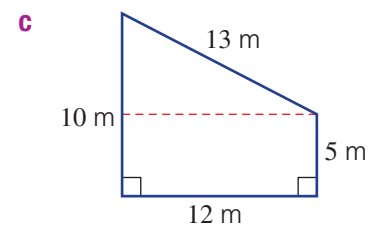
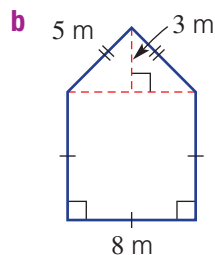
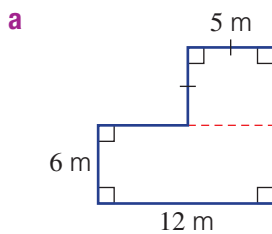
**Example 13 Finding more perimeters and areas**

This shape is a square with a quadrant (quarter circle) subtracted. Find its perimeter and area correct to two decimal places.

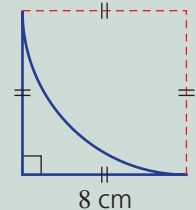
**Solution**

$$\begin{aligned} P &= 2 \times l + \frac{1}{4} \times 2\pi r \\ &= 2 \times 8 + \frac{1}{4} \times 2\pi \times 8 \\ &= 28.57 \text{ cm (to 2 d.p.)} \end{aligned}$$

$$\begin{aligned} A &= l^2 - \frac{1}{4} \times \pi r^2 \\ &= 8^2 - \frac{1}{4} \times \pi \times 8^2 \\ &= 13.73 \text{ cm}^2 \text{ (to 2 d.p.)} \end{aligned}$$

Explanation

Includes 2 sides and a quarter of the circumference of a circle of radius 8 cm.

Includes a square minus a quarter of the area of a circle of radius 8 cm.

6E

Now you try

This shape is a rectangle with a semicircle subtracted. Find its perimeter and area correct to two decimal places.

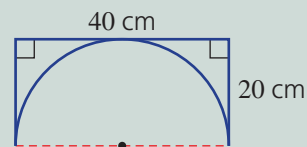

- 5 Find the perimeter and area of these shapes correct to two decimal places.

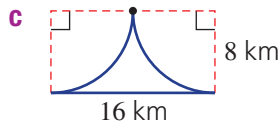
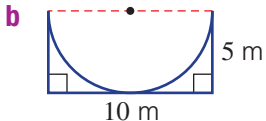
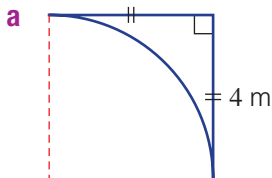

Hint: Use subtraction to find the area.



- 6 Find the area of the shaded part of these composite shapes.

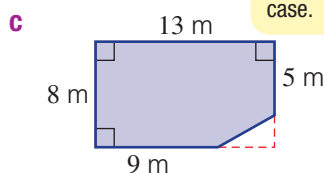
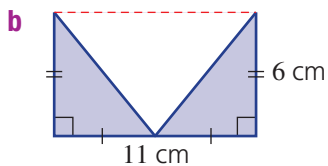
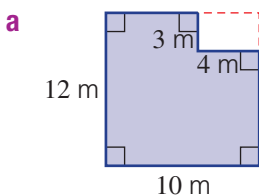

Hint: Use subtraction in each case.

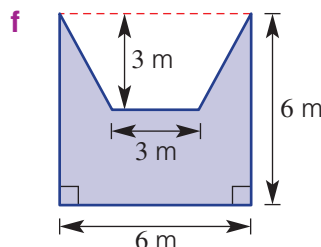
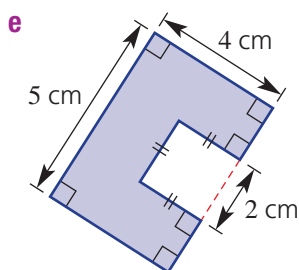
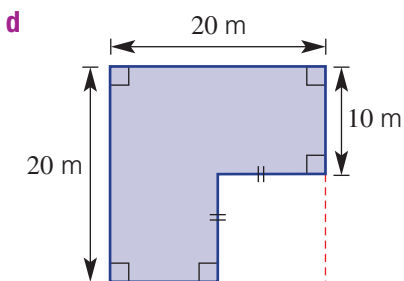

Problem-solving and reasoning

7, 8

8, 9(1/2), 10

- 7 An area of lawn is made up of a rectangle measuring 10 m by 15 m and a semicircle of radius 5 m. Find the total area of lawn correct to two decimal places.

- 8 Twenty circular pieces of pastry, each of diameter 4 cm, are cut from a rectangular layer of pastry 20 cm long and 16 cm wide. What is the area, correct to two decimal places, of pastry remaining after the 20 pieces are removed?



9 Find the area of the shaded region of each of the following shapes by subtracting the area of the clear shape from the total area. Round to two decimal places where necessary.

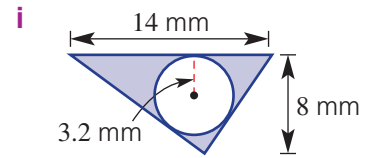
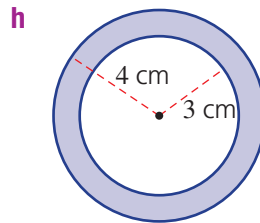
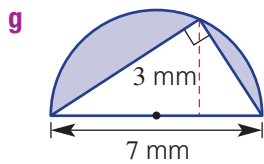
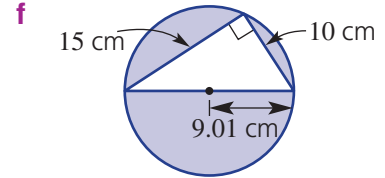
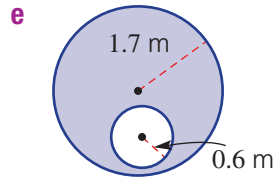
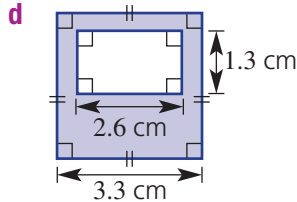
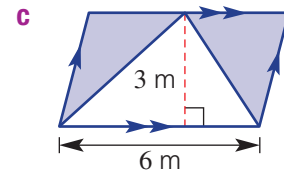
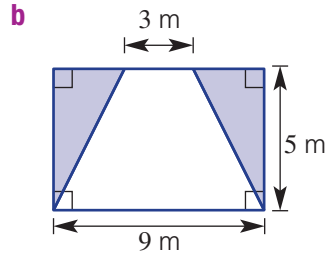
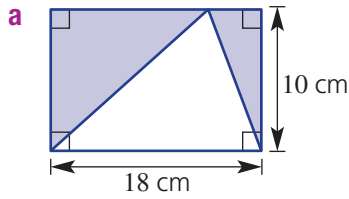

10 Find the area of each of the following composite shapes.

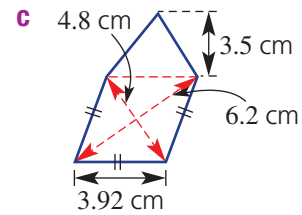
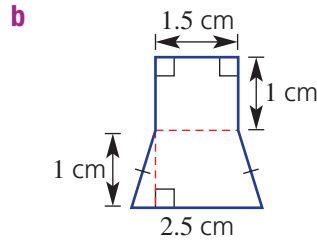
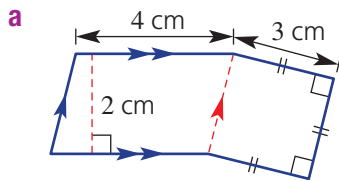

★ Circular challenges

11 Find the perimeter and the area of each of the following composite shapes correct to two decimal places where necessary.

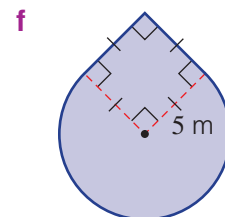
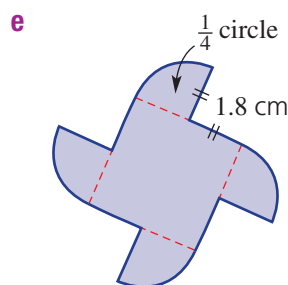
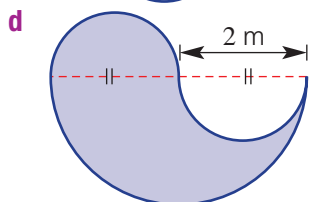
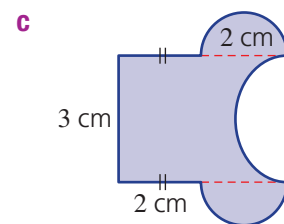
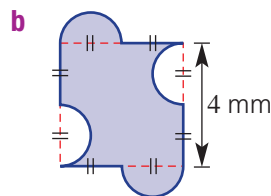
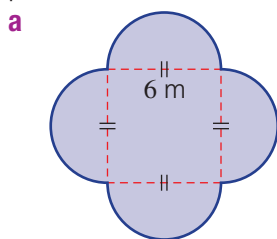

6F Surface area of prisms

Learning intentions

- To understand how the surface area of a solid can be represented using a net
- To be able to calculate the total surface area of a prism

Key vocabulary: total surface area, right prism, cross-section, uniform, net

Three-dimensional objects or solids have outside surfaces that together form the total surface area. Nets are very helpful for determining the number and shape of the surfaces of a three-dimensional object.

For this section we will deal with right prisms. A right prism has a uniform cross-section with two identical ends and the remaining sides are rectangles at right angles to the base and top.

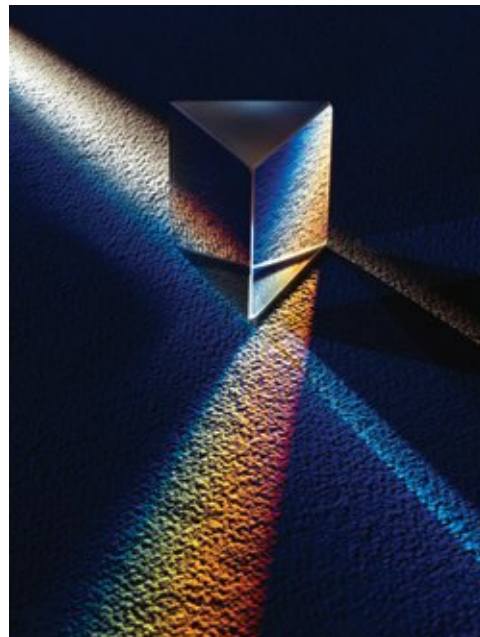
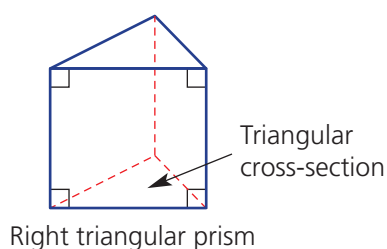

Lesson starter: Drawing prisms

Prisms are named by the shape of their cross-section.

- Try to draw as many different right prisms as you can.
- Describe the different types of shapes that make up the surface of your solids.
- Which solids are the most difficult to draw and why?

Key ideas

- The **total surface area** (TSA) of a solid is the sum of the areas of all the surfaces.
- A **net** is a two-dimensional illustration of all the surfaces of a solid.

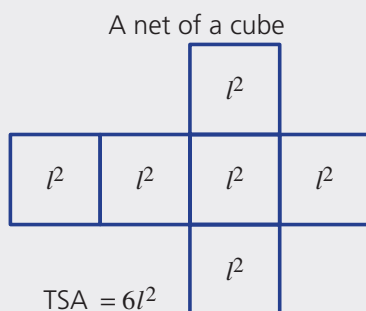
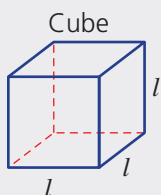

- A **right prism** is a solid with a **uniform** (constant) **cross-section** and with remaining sides as rectangles.
 - Prisms are named by the shape of their cross-section.

- The nets for a rectangular prism (cuboid) and triangular prism are shown here.

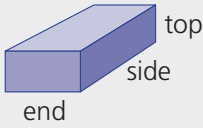
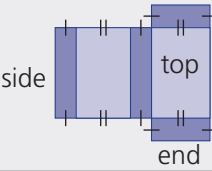
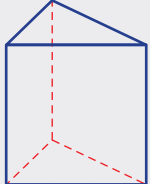
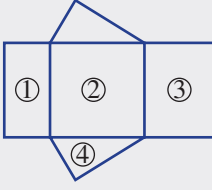
Solid	Net	TSA
Rectangular prism 		$TSA = 2 \times \text{top} + 2 \times \text{side} + 2 \times \text{end}$
Triangular prism 		$TSA = \text{area } \textcircled{1} + \text{area } \textcircled{2} + \text{area } \textcircled{3} + 2 \times \text{area } \textcircled{4}$

Exercise 6F

Understanding

1-3

3

- 1 How many faces do the following solids have?
- Rectangular prism
 - Cube
 - Triangular prism
- 2 Draw a suitable net for these prisms and name each solid.

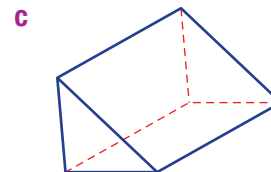
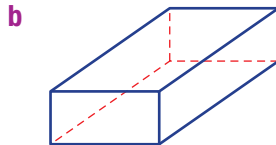
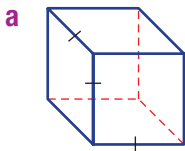

- 3 Copy and complete the working to find the surface area of these solids.

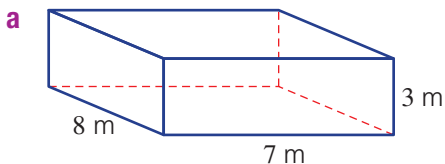

$$\begin{aligned}
 TSA &= 2 \times (8 \times 7) + 2 \times (8 \times \underline{\quad}) + 2 \times (\underline{\quad} \times \underline{\quad}) \\
 &= \underline{\quad} + \underline{\quad} + \underline{\quad} \\
 &= \underline{\quad} \text{ m}^2
 \end{aligned}$$

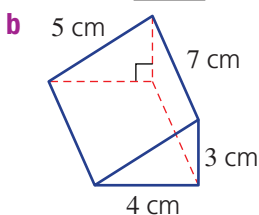

$$\begin{aligned}
 TSA &= 2 \times \frac{1}{2} \times 4 \times \underline{\quad} + 5 \times 7 + 4 \times \underline{\quad} + \underline{\quad} \times \underline{\quad} \\
 &= \underline{\quad} + \underline{\quad} + \underline{\quad} + \underline{\quad} \\
 &= \underline{\quad} \text{ cm}^2
 \end{aligned}$$

**Example 14 Finding a total surface area of a rectangular prism**

Find the total surface area of this rectangular prism.

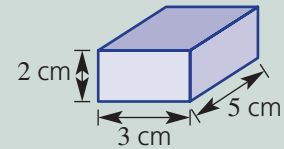
**Solution**

$$\begin{aligned} \text{TSA} &= 2 \times \text{top} + 2 \times \text{side} + 2 \times \text{end} \\ &= 2 \times (5 \times 3) + 2 \times (5 \times 2) + 2 \times (2 \times 3) \\ &= 30 + 20 + 12 \\ &= 62 \text{ cm}^2 \end{aligned}$$

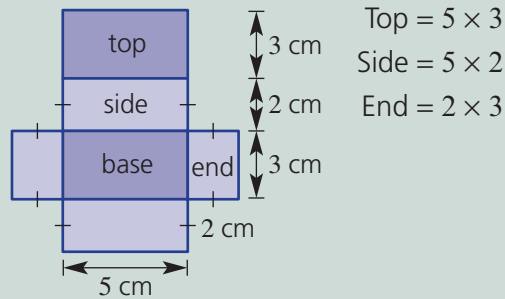
Explanation**Now you try**

Find the total surface area of this rectangular prism.

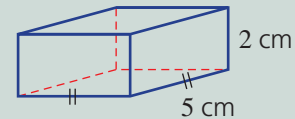

4 Find the surface area of the following rectangular prisms. Draw a net of the solid to help you.

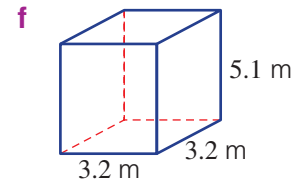
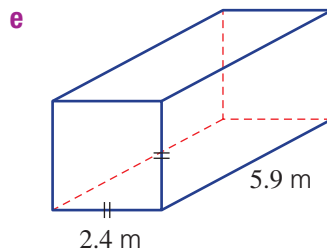
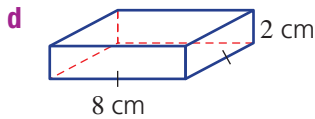
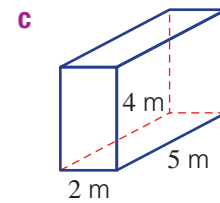
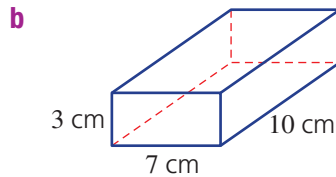
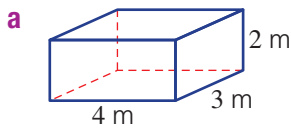

Hint: Add up all the pairs of rectangles using $A = l \times w$.

**Example 15 Finding the total surface area of a right triangular prism**

Find the total surface area of this triangular prism.

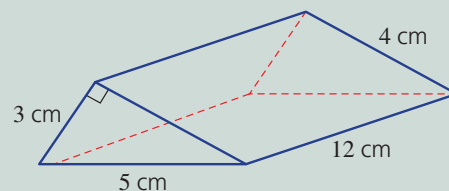

Solution

$$\begin{aligned}
 \text{TSA} &= \text{area } A + \text{area } B + \text{area } C + 2 \times \text{area } D \\
 &= 12 \times 4 + 12 \times 5 + 12 \times 3 + 2 \times \left(\frac{1}{2} \times 4 \times 3\right) \\
 &= 48 + 60 + 36 + 12 \\
 &= 156 \text{ cm}^2
 \end{aligned}$$

Explanation

Draw and label the surface area net.

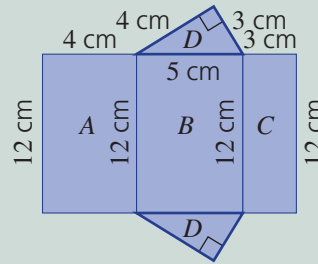

The surface is made up of three rectangles and two identical triangles. Use 3 cm and 4 cm for the base and height, respectively, of the triangles.

Now you try

Find the total surface area of this triangular prism.

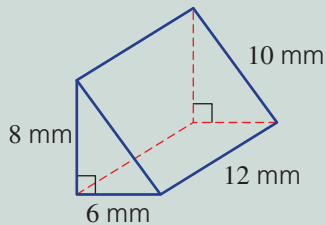

5 Find the surface area of each of the following triangular prisms.

a

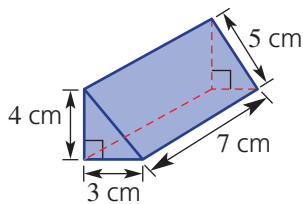

b

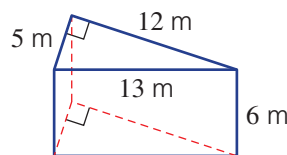

c

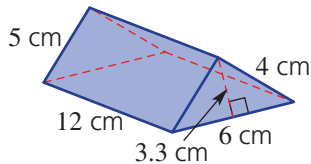

d

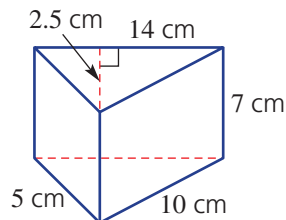

Hint: Each prism consists of three rectangles and two identical triangles.



6 Find the total surface area of a cube of side length 1 metre.

Problem-solving and reasoning

7, 8

8–10



7 A rectangular box is to be covered in material. How much is required to cover the entire box if it has the dimensions 1.3 m, 1.5 m and 1.9 m?



6F



- 8 Two wooden boxes, both with dimensions 80 cm, 1 m and 25 cm, are placed on the ground, one on top of the other, as shown. The entire outside surface, including the underside of the bottom box, is then painted. Find the area of the painted surface in cm^2 .

Hint: Only include the outside surfaces.

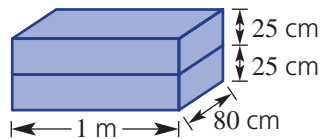

- 9 The four walls and roof of a barn (shown) are to be painted.
- Find the surface area of the barn, not including the floor.
 - If 1 litre of paint covers 10 m^2 , find how many litres are required to complete the job.

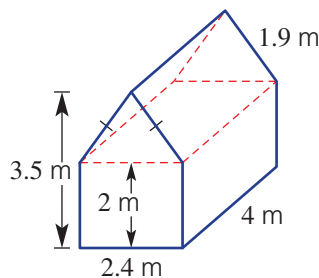

- 10 Cubes of side length one unit are stacked as shown.

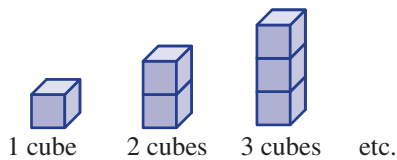

- a Complete this table.

Number of cubes (n)	1	2	3	4	5	6	7	8	9
Surface area (S)									

- Can you find the rule for the surface area (S) for n cubes stacked in this way? Write down the rule for S in terms of n .
- Use your rule to find the surface area if there are 100 cubes.

Hint: An example of a rule is $S = 2n + 5$, but this is not the rule for this question.



Pyramids

—



- 11 Pyramids consist of a base and a number of triangular faces. The TSA can be calculated by adding up all the face areas, similar to that of prisms. Remember that the area of a triangle is given by $A = \frac{1}{2}bh$. Find the surface area of each of these pyramids. Draw a net of the solid to help you.

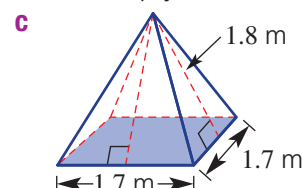
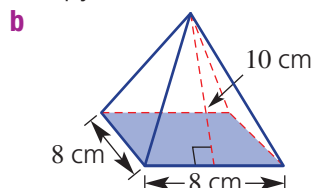
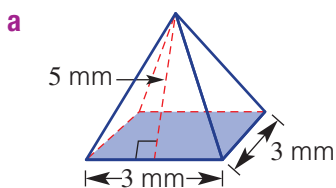

- 6A** 1 Find the perimeter of the following shapes.

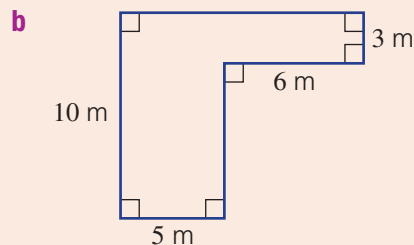
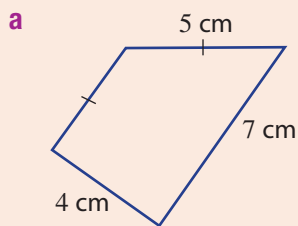

- 6B** 2 Find the circumference of these circles correct to two decimal places.

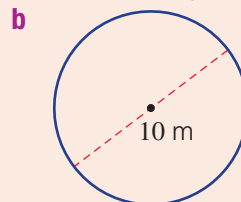
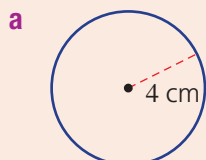

- 6A/6C** 3 Convert the following measurements into the units given in brackets.

- a** 824 cm (m)
- b** 30 cm (mm)
- c** 1.24 km (m)
- d** 3.6 m^2 (cm^2)
- e** 450 cm^2 (mm^2)
- f** 832 cm^2 (m^2)

- 6C** 4 Find the area of the following plane figures.

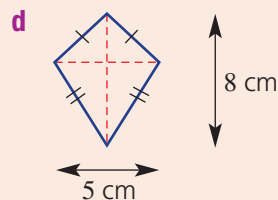
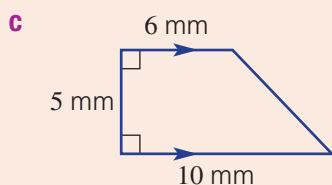
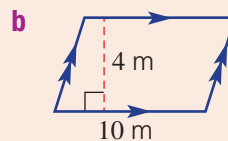
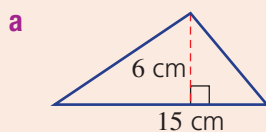

- 6D** 5 Find the area of the following circles correct to one decimal place.

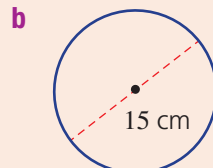
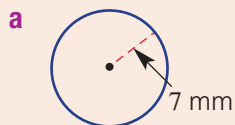

6B/6D



- 6 For the semicircle shown, find (correct to one decimal place):
 a its perimeter b its area

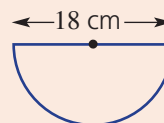

6E



- 7 For each of the composite shapes, find (correct to one decimal place where necessary):
 i its perimeter ii its area

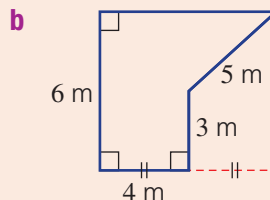
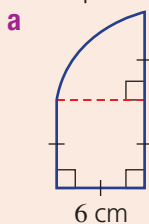

6F

- 8 Find the total surface area of these prisms.

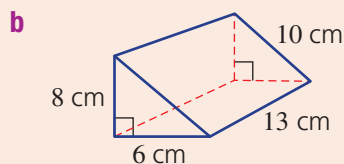
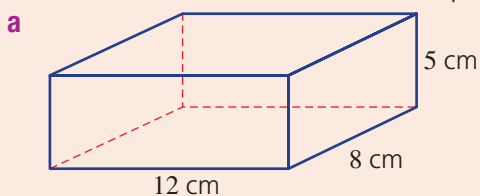

6G Surface area of a cylinder

Learning intentions

- To understand how the net of a cylinder can be drawn to show the total surface area
- To know the formula for the total surface area of a cylinder
- To be able to calculate the total surface area of a cylinder and simple cylindrical portions

Key vocabulary: cylinder, area, prism, circumference, net, congruent, cross-section

Like a rectangular prism, a cylinder has a uniform cross-section (a circle), but because it doesn't have rectangular sides, it isn't classified as a right prism.

A cylinder's total surface area can be found by considering the curved part as a rectangle with length $2\pi r$ (or πd) and height h .

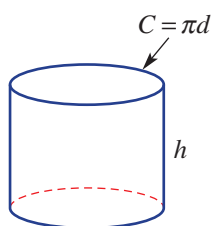

Lesson starter: Curved area

- Roll a piece of paper to form the curved surface of a cylinder.
- Do not stick the ends together, so that you can allow the paper to return to a flat surface.
- What shape is the paper when lying flat on a table?
- When curved to form the cylinder, what do the sides of the rectangle represent on the cylinder? How does this help to find the surface area of a cylinder?

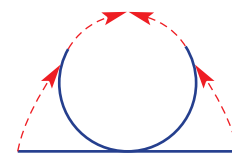

Key ideas

- A **cylinder** is a solid with two parallel, **congruent** circular faces connected by a curved surface.
- Surface area of a cylinder = 2 circles + rectangle

$$= 2 \times \pi r^2 + 2\pi r \times h$$

$$\therefore \text{TSA} = 2\pi r^2 + 2\pi r h$$

2 circular ends
Curved area

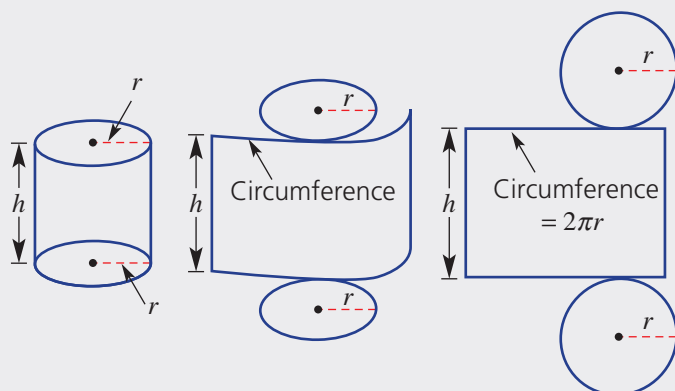

Exercise 6G

Understanding

1–4

4

- 1 The formula for the surface area of a cylinder is $TSA = 2\pi r^2 + 2\pi rh$.
- Which part of the formula works out the area of the curved surface?
 - Which part of the formula works out the area of the two ends?



- 2 Find the circumference of the circular end of these cylinders. Round to two decimal places.

Hint: Use $C = \pi d$ or $C = 2\pi r$.

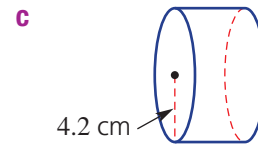
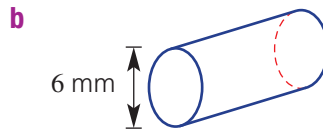
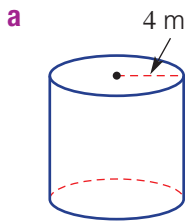

- 3 Draw a net suited to these cylinders. Label the sides using the given measurements.

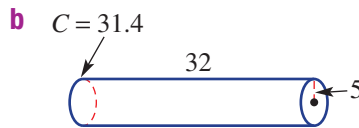
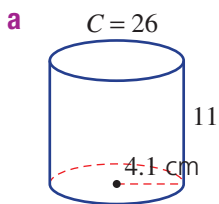

- 4 The curved surface of these cylinders is allowed to flatten out to form a rectangle. What would be the length and width of the rectangles? Round to two decimal places where necessary.

Hint: Length = $2\pi r$

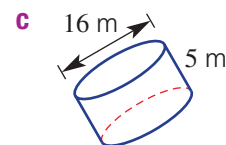
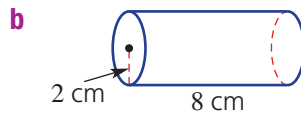
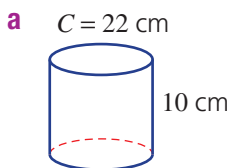

A rectangular piece of paper will cover the curved surface of a cylinder. The length of the piece of paper needed to fully cover the cylinder's curved surface will be the same as the height of the cylinder. The width of the paper will be the same as the circumference of the cylinder.

Fluency

5, 6

5, 7



Example 16 Finding the surface area of a cylinder

Find the surface area of this cylinder, rounding to two decimal places.

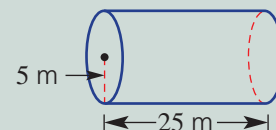

Solution

$$\begin{aligned}\text{Area of ends} &= 2 \times \pi r^2 \\ &= 2 \times \pi \times 5^2 \\ &= 50\pi \text{ m}^2\end{aligned}$$

$$\begin{aligned}\text{Area of rectangle} &= l \times w \\ &= 2\pi r \times h \\ &= 2\pi \times 5 \times 25 \\ &= 250\pi \text{ m}^2\end{aligned}$$

$$\begin{aligned}\text{TSA} &= 50\pi + 250\pi \\ &= 942.48 \text{ m}^2 \text{ (to 2 d.p.)}\end{aligned}$$

Explanation

The TSA consists of two circles ($2\pi r^2$) plus a rectangle where $l \times w = 2\pi r \times h$.

When adding to find the TSA, use your exact answers in your calculator for each part, then add to get the total surface area.

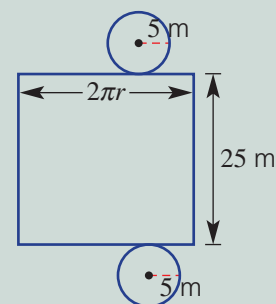

Now you try

Find the surface area of this cylinder, rounding to two decimal places.

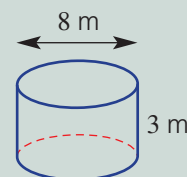

5 Find the surface area of these cylinders, rounding to two decimal places.

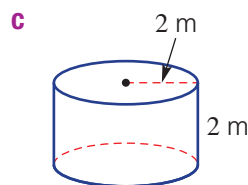
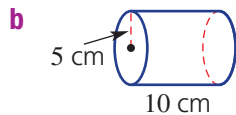
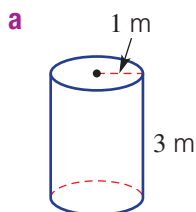

Hint: Draw a net to help:

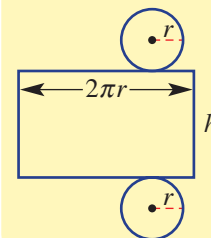

6 Find the surface area of these cylinders, rounding to one decimal place.

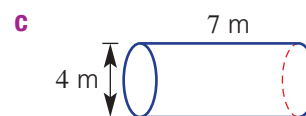
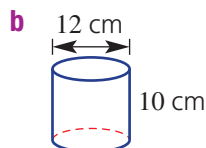
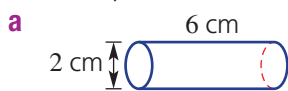

Hint: Remember that the radius of a circle is half the diameter.



6G



7 Find the area of the curved surface only for these cylinders, correct to two decimal places.

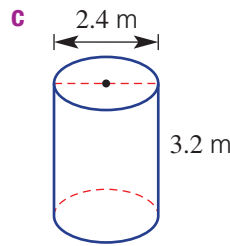
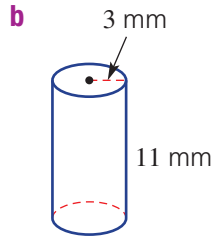
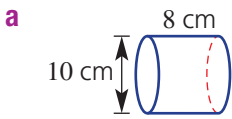

Hint: For the curved part only, use $A = 2\pi r \times h$.



Problem-solving and reasoning

8, 9(1/2)

9(1/2), 10, 11



8 Find the surface area of a cylindrical plastic container of height 18 cm and with a circle of radius 3 cm at each end, correct to two decimal places.



Example 17 Finding surface areas of cylindrical portions

Find the surface area of this half cylinder, rounding to two decimal places.

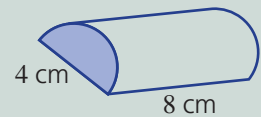

Solution

$$\begin{aligned} \text{Area (two semicircles)} &= \pi r^2 \\ &= \pi \times 2^2 \\ &= 4\pi \text{ cm}^2 \end{aligned}$$

$$\begin{aligned} \text{Area (rectangles)} &= 8 \times 4 + 8 \times \frac{1}{2} \times 2\pi \times 2 \\ &= 32 + 16\pi \text{ cm}^2 \end{aligned}$$

$$\begin{aligned} \text{TSA} &= 4\pi + 32 + 16\pi \\ &= 94.83 \text{ cm}^2 \text{ (to 2 d.p.)} \end{aligned}$$

Explanation

The two semicircles combine to form a full circle.

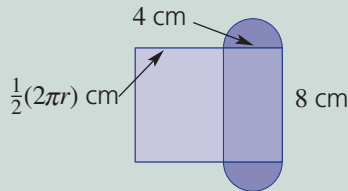

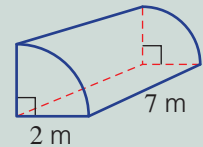

Now you try

Find the surface area of this quarter cylinder, rounding to two decimal places.

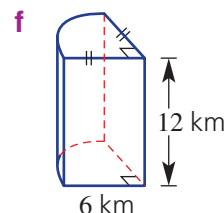
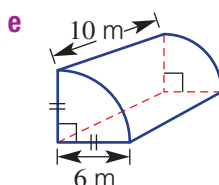
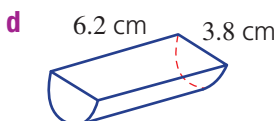
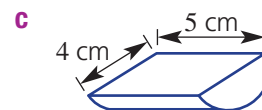
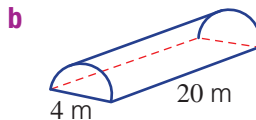
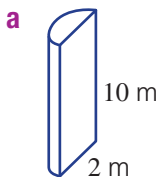

9 Find the surface area of these solids, rounding to two decimal places.



-  **10** A water trough is in the shape of a half cylinder. Its semicircular ends have diameter 40 cm and the trough length is 1 m. Find the outside surface area, in cm^2 , of the curved surface plus the two semicircular ends, correct to two decimal places.



- 11** A solid cylinder cut in half gives half the volume but not half the surface area. Explain why.



Roller revolutions

12

-  **12** A cylindrical roller is used to press crushed rock in preparation for a tennis court. The entire rectangular tennis court area is 30 m long and 15 m wide. The roller has a width of 1 m and diameter 60 cm.

- a** Find the surface area of the curved part of the roller, in cm^2 , correct to three decimal places.
- b** Find the area, in m^2 to two decimal places, of crushed rock that can be pressed after:
- i** 1 revolution **ii** 20 revolutions
- c** Find the minimum number of complete revolutions required to press the entire tennis court area.

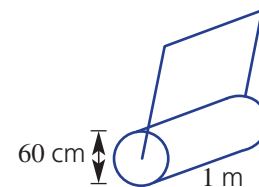

Hint: $1 \text{ m}^2 = 100 \times 100 \text{ cm}^2$



6H Volume

Learning intentions

- To be able to convert between metric units of volume
- To understand how the volume of a solid relates to its constant cross-section and height
- To know the common units for capacity
- To know the formula for the volume of a rectangular prism
- To be able to calculate the volume of a solid with a uniform cross-section

Key vocabulary: solid, volume, cross-section, uniform, prism, perpendicular, capacity, litres, millilitres

We use volume to describe the amount of space inside a three-dimensional object. We use metric units, such as:

- cubic kilometres for the volume of water in the sea
- cubic metres for the volume of concrete poured at a building site
- cubic centimetres for the volume of space occupied by this book
- cubic millimetres for the volume of metal in a pin.

Units for capacity (millilitres, litres, kilolitres and megalitres) are used for liquids and gases.

→ Lesson starter: Why length \times width \times height?

For most people, the first thing that often comes to mind when dealing with volume is length \times width \times height. But this rule only applies to finding the volume of rectangular prisms.

Let's look at a rectangular prism split into two layers.

- How many cubes sit on one layer?
- What is the area of the base? What do you notice?
- What is the height and how many layers are there?
- Why is the volume rule given by $V = lwh$ in this case?

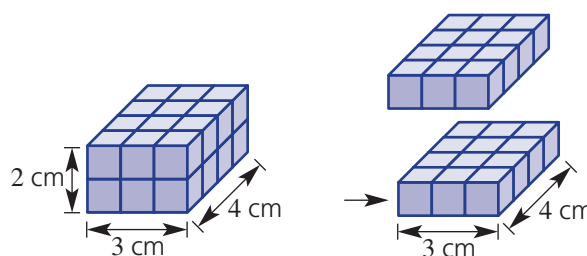

Key ideas

- **Volume** is the amount of three-dimensional space inside an object.
- Common metric units for volume include cubic kilometres (km^3), cubic metres (m^3), cubic centimetres (cm^3) and cubic millimetres (mm^3).

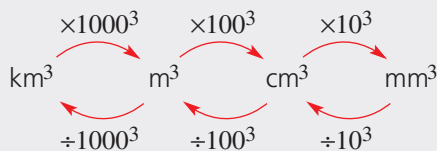

$$1000^3 = 1\,000\,000\,000$$

$$100^3 = 1\,000\,000$$

$$10^3 = 1000$$

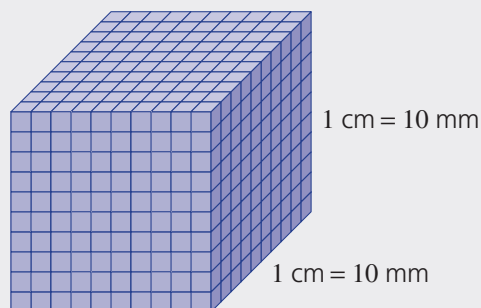

$$1\text{ cm} = 10\text{ mm}$$

$$1\text{ cm}^3 = 10 \times 10 \times 10\text{ mm}^3$$

$$= 10^3\text{ mm}^3$$

- **Capacity** is the amount of liquid a container can hold.
 - For capacity, common units include:
 - megalitres (ML) 1 ML = 1000 kL
 - kilolitres (kL) 1 kL = 1000 L
 - litres (L) 1 L = 1000 mL
 - millilitres (mL)
 - Also: $1 \text{ cm}^3 = 1 \text{ mL}$ so $1 \text{ L} = 1000 \text{ cm}^3$ and $1 \text{ m}^3 = 1000 \text{ L}$
- A **cross-section** is the plane figure formed when you slice a solid figure parallel to one of its surfaces.
 - Volume of solids with a uniform cross-section is equal to area of cross-section (A) multiplied by height (h).
 $V = A \times h$
 - The 'height' is the length of the edge that runs perpendicular to the cross-section in any solid.

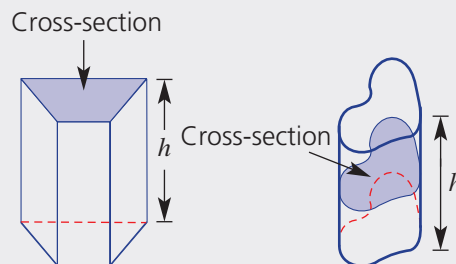

- Volume of a rectangular prism:

$$V = l \times w \times h$$

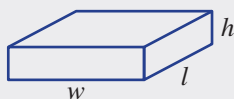

Exercise 6H

Understanding

1-3

3

- 1 What is the name given to the shape of the shaded cross-section of each of the following solids?

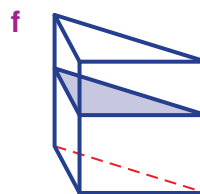
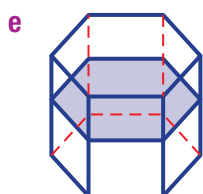
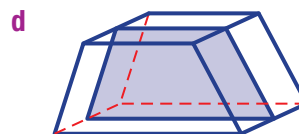
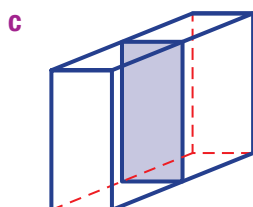
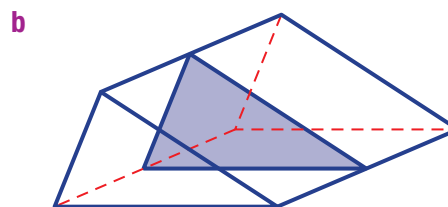
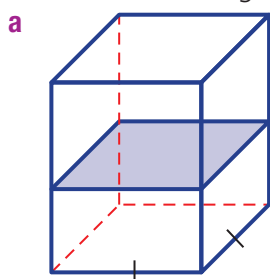

6H

- 2 Draw the cross-sectional shape for these prisms and state the given 'height' (perpendicular to the cross-section).

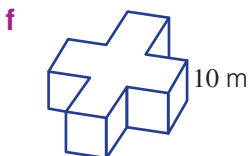
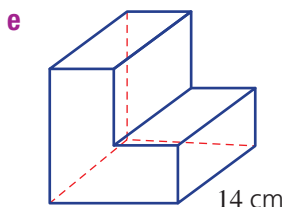
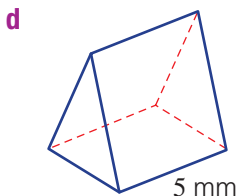
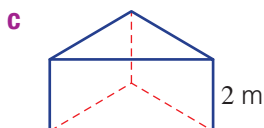
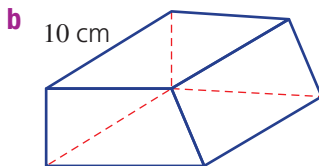
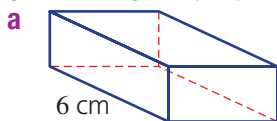

Hint: 'Perpendicular' means 'at a right angle (90°)'.



- 3 Write the missing number.

a The number of mm in 1 cm is _____.

b The number of mm^2 in 1 cm^2 _____.

c The number of mm^3 in 1 cm^3 is _____.

d There are _____ cm^3 in 1 m^3 .

e There are _____ m^3 in 1 km^3 .

f There are _____ mL in 1 L.

g There are _____ L in 1 kL.

h There is _____ cm^3 in 1 mL.

Fluency

4–5($\frac{1}{2}$), 6, 84–5($\frac{1}{2}$), 7, 8($\frac{1}{2}$), 9

Example 18 Converting units of volume

Convert the following volume measurements into the units given in the brackets.

a 2.5 m^3 (cm^3)

b 458 mm^3 (cm^3)

Solution

Explanation

$$\begin{aligned} \text{a } 2.5 \text{ m}^3 &= 2.5 \times 100^3 \text{ cm}^3 \\ &= 2\,500\,000 \text{ cm}^3 \end{aligned}$$

$$\begin{aligned} &\times 100^3 = 1\,000\,000 \\ &\text{m}^3 \quad \text{cm}^3 \quad 2.500000 \end{aligned}$$

$$\begin{aligned} \text{b } 458 \text{ mm}^3 &= 458 \div 10^3 \text{ cm}^3 \\ &= 0.458 \text{ cm}^3 \end{aligned}$$

$$\begin{aligned} &\text{cm}^3 \quad \text{mm}^3 \\ &\div 10^3 = 1000 \quad 458. \end{aligned}$$

Now you try

Convert the following volume measurements into the units given in the brackets.

a 0.6 cm^3 (mm^3)

b $4\,520\,000 \text{ cm}^3$ (m^3)

- 4 Convert the following volume measurements into the units given in brackets.

a 3 cm^3 (mm^3)

b 0.3 cm^3 (mm^3)

c 2000 mm^3 (cm^3)

d 0.001 m^3 (cm^3)

e 8.7 m^3 (cm^3)

f 5900 cm^3 (m^3)

g 0.00001 km^3 (m^3)

h $21\,700 \text{ m}^3$ (km^3)

i $430\,000 \text{ cm}^3$ (m^3)

Hint: $1 \text{ km}^3 = 1000^3 \text{ m}^3$
 $1 \text{ m}^3 = 100^3 \text{ cm}^3$
 $1 \text{ cm}^3 = 10^3 \text{ mm}^3$





Hint:
 1 ML = 1000 kL
 1 kL = 1000 L
 1 L = 1000 mL
 1 cm³ = 1 mL

- 5 Convert these units of capacity to the units given in brackets.
- | | | |
|---------------------------------|---------------------------------|-------------------------------|
| a 3 L (mL) | b 0.2 kL (L) | c 3500 mL (L) |
| d 0.021 L (mL) | e 37 000 L (kL) | f 42 900 kL (ML) |
| g 2 cm ³ (mL) | h 2 L (cm ³) | i 1 m ³ (L) |



Example 19 Finding the volume of a rectangular prism

Find the volume of this rectangular prism.

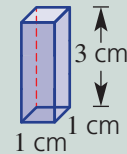

Solution

$$\begin{aligned}\text{Volume} &= l \times w \times h \\ &= 1 \times 1 \times 3 \\ &= 3 \text{ cm}^3\end{aligned}$$

Explanation

The solid is a rectangular prism.
 Length = 1 cm, width = 1 cm and height = 3 cm

Now you try

Find the volume of this rectangular prism.

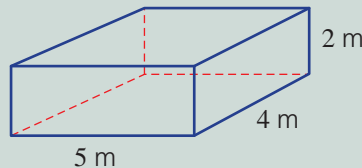

- 6 Find the volume of these three-dimensional rectangular prisms.

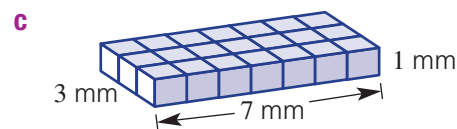
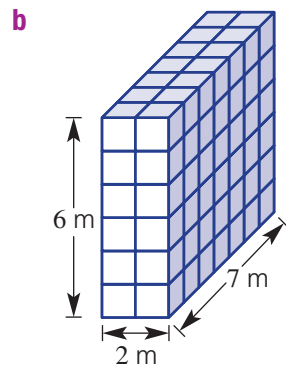
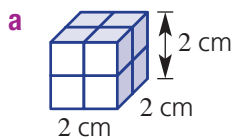

- 7 Find the volume of each of these rectangular prisms (cuboids).

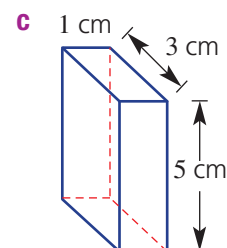
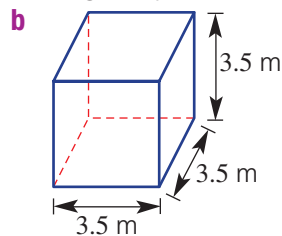
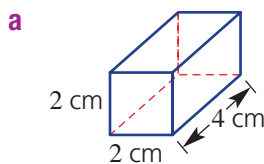

6H



8 Find the volume of each of these three-dimensional objects. The cross-sectional area has been given.

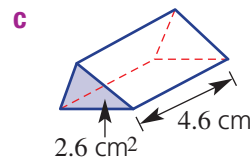
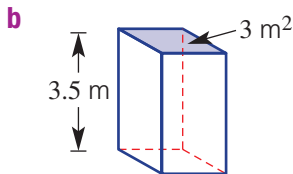
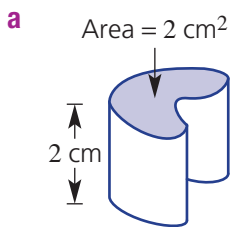

Hint: Simply use $V = A \times h$, since the area of the cross-section is given.

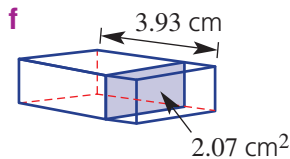
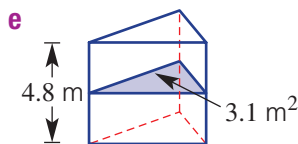
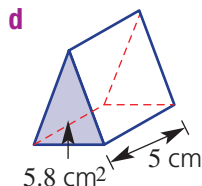

Example 20 Finding the volume of a triangular prism



Find the volume of this triangular prism.

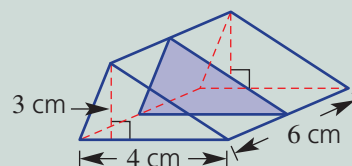

Solution

$$\begin{aligned} \text{Area of cross-section} &= \frac{1}{2} \times b \times h \\ &= \frac{1}{2} \times 4 \times 3 \\ &= 6 \text{ cm}^2 \end{aligned}$$

$$\begin{aligned} \text{Volume} &= \text{area of cross-section} \times \text{height} \\ &= 6 \times 4 \\ &= 24 \text{ cm}^3 \end{aligned}$$

Explanation

The cross-section is a triangle.

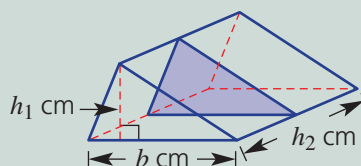

Now you try

Find the volume of this triangular prism.

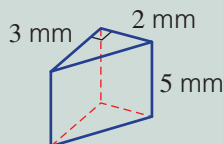

9 Find the volume of these prisms.

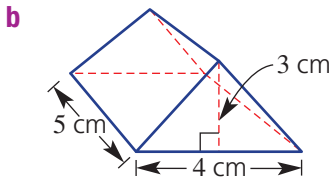
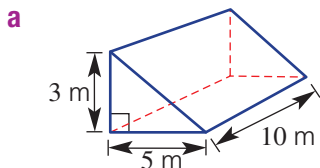

Hint: First find the area of the triangular cross-section.
 $A = \frac{1}{2}bh$

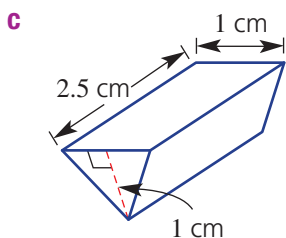

Problem-solving and reasoning

10, 11

11–13

- 10 A rectangular container is 10 cm wide, 20 cm long and 8 cm high. What is the capacity of the container in litres?

Hint: There are 1000 cm³ in 1 L.

- 11 25 L of water is poured into a rectangular fish tank which is 50 cm long, 20 cm wide and 20 cm high. Will it overflow?

- 12 Find the volume of these solids, converting your answer to litres.

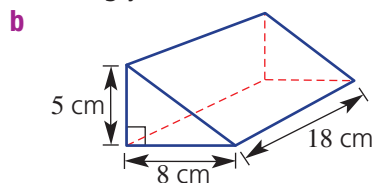
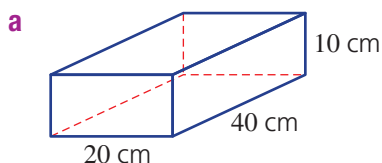

Hint: Area of a trapezium:

$$A = \frac{1}{2}(a + b)h$$

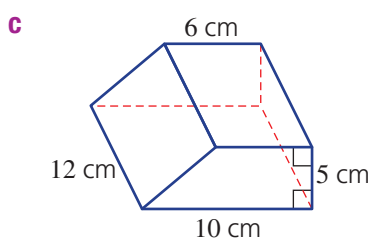

- 13 This diagram is a sketch of a new 25 m swimming pool to be installed in a school sports complex.

- a** Find the area of one side of the pool (shaded).

- b** Find the volume of the pool in litres.
Use 1 m³ = 1000 L.

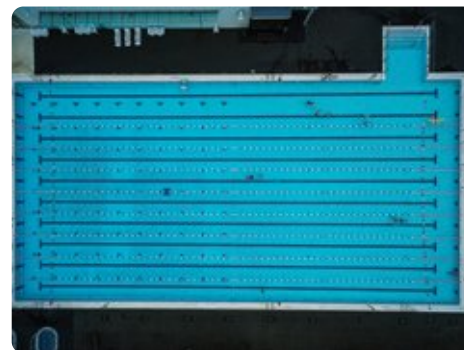
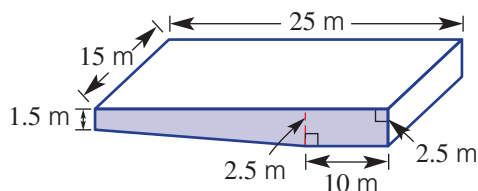

Volume of a pyramid

—

14

- 14 Someone tells you that the volume of a pyramid is half of the volume of a rectangular prism with the same base. Do you think this is true?
- a** Make an educated guess as to what fraction of the prism's volume is the pyramid's volume.
- b** Use the internet to find the actual answer to part **a**.
- c** Draw some pyramids and find their volume using the results from part **b**.

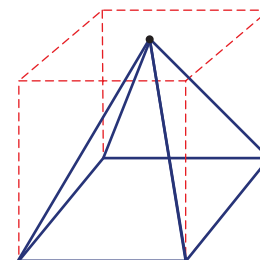

6I Volume of a cylinder

Learning intentions

- To know the formula for the volume of a cylinder
- To be able to find the volume of a cylinder
- To be able to find the capacity of a cylinder in litres

Key vocabulary: volume, cylinder, capacity, radius, diameter

A cylinder with its sides at right angles to its base is called a right cylinder. It has a uniform cross-section (a circle), so its volume can be calculated in a similar way to that of a prism. Cylindrical objects are often used to store gases and liquids, so working out the volume of a cylinder is an important measurement calculation.



→ Lesson starter: How is a cylinder like a prism?

Here is a cylinder and two prisms.

- What do they all have in common?
- Do you think you can work out the volume of the cylinder in the same way as for a prism? Why?
- What do you think the formula would be for the volume of a cylinder?

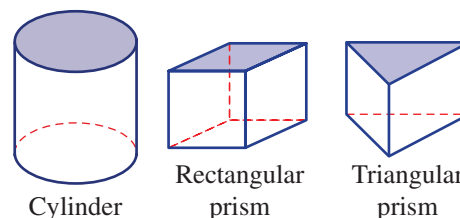

Key ideas

- The volume of a cylinder is given by $V = \pi r^2 \times h$ or $V = \pi r^2 h$
 - r is the radius of the circular ends
 - h is the length or distance between the circular ends

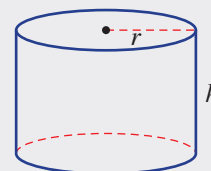

Exercise 6I

Understanding

1–3(½)

2–3(½)



- 1 Find the area of these circles correct to two decimal places.

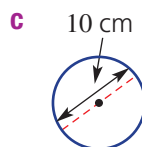
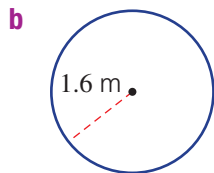
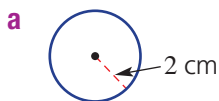

- 2 Convert the following into the units given in the brackets. Remember: $1 \text{ L} = 1000 \text{ cm}^3$ and $1 \text{ m}^3 = 1000 \text{ L}$.

a 2000 cm^3 (L)

b 4.3 cm^3 (mL)

c 3.7 L (cm^3)

d 1 m^3 (L)

e $38\,000 \text{ L}$ (m^3)

f 0.0002 m^3 (mL)

3 State the radius (r) and the height (h) of these cylinders.

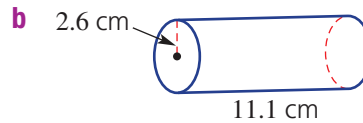
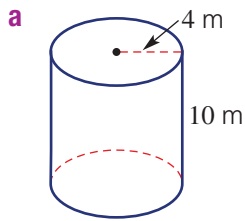

Hint: The height is perpendicular (at 90°) to the circular ends.

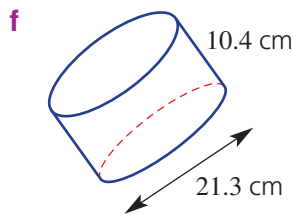
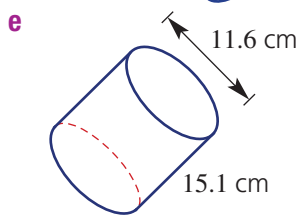
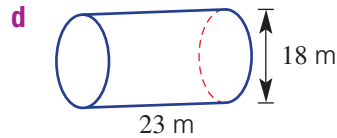
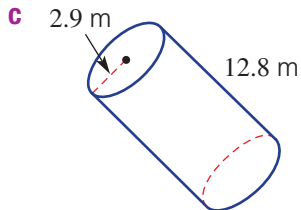

Fluency

4

4(1/2)



Example 21 Finding the volume of a cylinder

Find the volume of these cylinders correct to two decimal places.

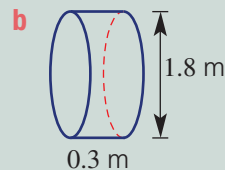
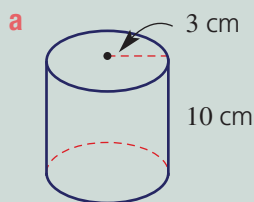

Solution

a $V = \pi r^2 h$
 $= \pi \times (3)^2 \times 10$
 $= 282.74 \text{ cm}^3$ (to 2 d.p.)

b $V = \pi r^2 h$
 $= \pi \times (0.9)^2 \times 0.3$
 $= 0.76 \text{ m}^3$ (to 2 d.p.)

Explanation

πr^2 gives the area of the circular cross-section and h is the distance between the ends. Substitute $r = 3$ and $h = 10$ into the rule.

The diameter is 1.8 m so $r = 0.9$ m. The distance between the ends is 0.3 m, so $h = 0.3$.

Now you try

Find the volume of these cylinders correct to two decimal places.

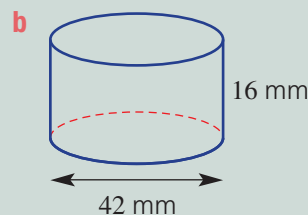
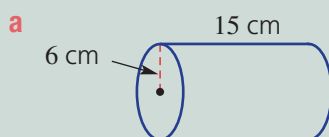

61



4 Find the volume of these cylinders correct to two decimal places.

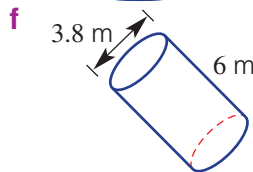
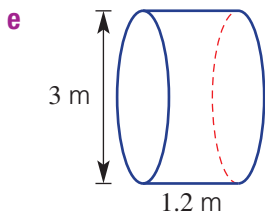
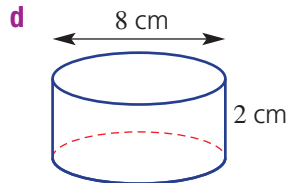
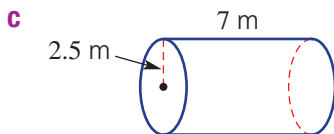
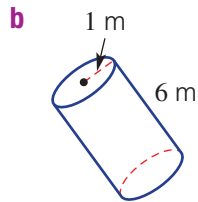
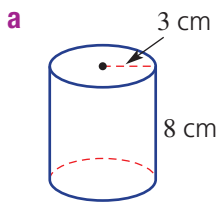

Hint: Substitute the values of r and h into $V = \pi r^2 h$. Note that $r = d \div 2$ for parts **d**, **e** and **f**.



Problem-solving and reasoning

5(½), 6, 7

5(½), 7–10



Example 22 Finding the capacity of a cylinder

Find the capacity, in litres, of a cylinder with radius 30 cm and height 90 cm. Round to the nearest litre.

Solution

$$\begin{aligned} V &= \pi r^2 h \\ &= \pi \times (30)^2 \times 90 \\ &= 254\,469 \text{ cm}^3 \\ &= 254 \text{ L (to nearest litre)} \end{aligned}$$

Explanation

Substitute $r = 30$ and $h = 90$.

There are 1000 cm^3 in 1 L, so divide by 1000 to convert to litres.

Now you try

Find the capacity, in litres, of a cylinder with diameter 20 cm and height 45 cm. Round to the nearest litre.





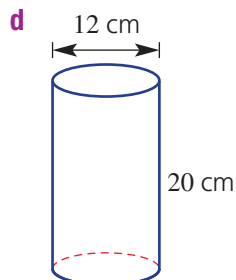
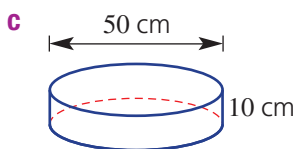
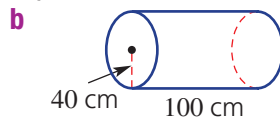
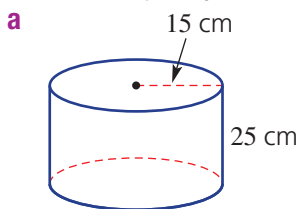

5 Find the capacity, in litres, of these cylinders. Round to the nearest litre.



Hint: First work out the volume in cm^3 and then use $1 \text{ L} = 1000 \text{ cm}^3$ to find the capacity in litres.



-  **6** A cylindrical storage drum has a radius of 0.5 m and a height of 2 m.
a Find its volume, in m^3 , correct to three decimal places.
b Find its volume, in L, correct to the nearest litre ($1 \text{ m}^3 = 1000 \text{ L}$).
-  **7** Which has a greater capacity: a 10 cm by 10 cm by 10 cm cube or a cylinder with radius 6 cm and height 10 cm?
-  **8** A cylindrical water tank has a radius of 2 m and a height of 2 m.
a Find its capacity, in m^3 , rounded to three decimal places.
b Find its capacity, in L, rounded to the nearest litre.
-  **9** How many litres of gas can a tanker carry if its tank is cylindrical with a 2 m diameter and is 12 m in length? Round to the nearest litre.

Hint:
 $1 \text{ m}^3 = 1000 \text{ L}$.



- 10** Draw a cylinder with its circumference equal to its height. Try to draw it to scale.



Cylinder portions

11

-  **11** Find the volume of these cylindrical portions correct to two decimal places.

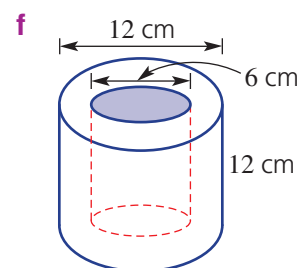
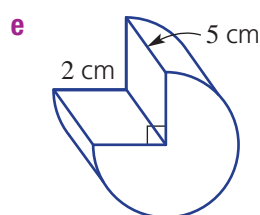
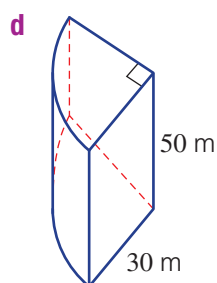
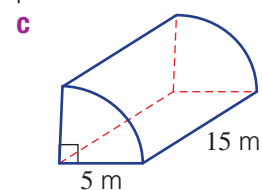
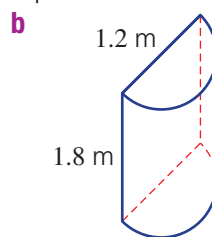
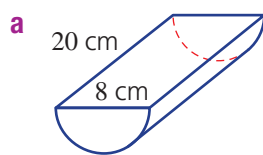



Maths@Work: Vegetable and fruit growers

The importance of farming in Australia can never be underestimated. From small scale gardens to commercial agriculture, farmers and their crops are essential for our food supply. Mathematics plays a major role in the profitable management of farms, including analysis of the optimum planting times, weather cycles, irrigation rates, pricing and production costs.

The issue of water usage and storage is very important in Australia. Farmers regularly measure soil moisture content to find out what is happening around the roots of crops. Irrigation is managed according to plant watering needs, rainfall and evaporation rates.



- Farmers need to be able to convert the volume of their dams from cubic metres (m^3) to megalitres (ML) by dividing by 1000.
 - Convert each of the following into ML.
 - 890 m^3
 - $60\,000 \text{ m}^3$
 - $800\,000 \text{ m}^3$
 - $380\,000 \text{ m}^3$
 - $190\,000\,000 \text{ m}^3$
 - Convert the following into cubic metres.
 - 9 ML
 - 1.2 ML
 - 120 ML
 - 0.98 ML
 - 12 000 ML
- The volume of a property dam is estimated with the formula, $\text{volume} = SA \times d \times 0.4$ where SA = the surface area of the top of the dam; d = maximum depth of the dam; and the factor of 0.4 allows for the dam's sloping sides.

Calculate the volume of the following farm dams.

 - Surface area = 600 m^2 , maximum depth 3 m
 - Surface area = 400 m^2 , maximum depth 2.5 m
 - Surface area = 800 m^2 , maximum depth 4 m
 - Surface area = 5000 m^2 , maximum depth 5 m
 - Surface area = $16\,000 \text{ m}^2$, maximum depth 6 m
- Concrete water storage tanks can be in the shape of cylinders. Calculate the capacity in litres and kilolitres for each water tank illustrated below. Recall that $1 \text{ m}^3 = 1000 \text{ L} = 1 \text{ kL}$.
 - Height 1.8 m, diameter 8.2 m
 - Height 1.5 m, diameter 5 m



Hint: Recall that the volume of a cylinder is $V = \pi r^2 h$.



Using technology

- 4 A soil moisture probe is a device that measures the percentage of water in soil.
- Maximum % of soil moisture is when soil is drenched.
 - Minimum % of soil moisture is when plants wilt.

The difference between these percentages is the percentage of soil water that a plant uses. The depth of watering needed for plants is measured in mm, like rainfall.

Plant watering depth = percentage moisture used by plant × root depth in mm

Set up the Excel spreadsheet below to calculate watering depth for the given plants.

Hint: Format columns B, C and D as 'percentage' and enter the decimal values in each cell; e.g. enter 0.43 for 43%.



	A	B	C	D	E	F
1	Calculation of watering depths for various plants					
2	Plant	Maximum moisture percentage	Minimum moisture percentage	Percentage moisture used by plant	Root depth in mm	Plant watering depth in mm
3	Onions	41%	37%		400	
4	Carrots	43%	38%		600	
5	Tomatoes	47%	43%		1200	
6	Apple trees	47%	41%		1500	
7	Banana trees	49%	38%		600	

- 5 Fruit trees can be micro-irrigated by dripping or spraying water in a circular area near the trunk. The volume of water required for each tree is calculated using the formula for volume of a cylinder:

$$V = \pi r^2 h = \pi r^2 \times \text{plant watering depth}$$

Note that an area of 1 m² covered by 1 mm of water = 1 L of water; hence area in m² multiplied by depth in mm gives volume in litres.

Set up the Excel spreadsheet shown below to calculate the litres of irrigation water required per 100 trees.

Hint: Use the plant watering depth values calculated in Question 4.



	A	B	C	D	E	F
1	Volume of irrigation water required for 100 trees					
2	Plant	Radius in m of micro-irrigation	Area of irrigation in m ²	Plant watering depth in mm	Litres of water per plant per irrigation	Litres of water per 100 trees
3	Apple trees	0.21				
4	Banana trees	0.32				

Pressing a new road

The construction of a new asphalt road involves pressing the surface with a roller. Two rollers are available, each with main roller wheels of varying diameter and width. The options are:

- Roller 1: Wheel diameter 1 metre and width 2 metres
- Roller 2: Wheel diameter 1.2 metres and width 2.5 metres.

The cost of hiring each roller depends on the number of revolutions in the following way:

- Roller 1: \$2.20 per revolution
- Roller 2: \$3 per revolution.

The rectangular section of road being built is 1 km long and 10 metres wide.

Present a report for the following tasks and ensure that you show clear mathematical workings and explanations where appropriate.

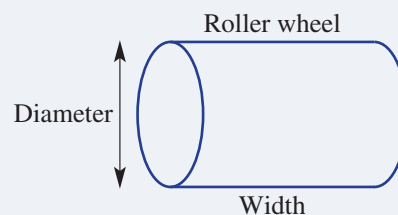

Preliminary task

- Write the formula for finding the curved surface area of a cylinder using the pronumerals r and h .
- What is the value of r and h for;
 - Roller 1
 - Roller 2
- For Roller 1 find,
 - the surface area of the roller wheel (the curved surface area only)
 - the area of ground pressed after 10 revolutions.
- Find the total surface area, in square metres, of a section of road which is 1 km long and 10 metres wide.
- How many rotations of the wheel would need to occur if roller 1 was to travel a single length of the 1 km length of road? Round to one decimal place.

Modelling task

The problem is to determine the cost of hiring each roller to press the entire 1 km stretch of road.

- Write down all the relevant information that will help solve this problem with the aid of diagrams.
-
- Using Roller 1 determine the total number of revolutions that the wheel needs to rotate if the entire 10 metre-wide road is to be pressed. Use the following assumptions.
 - It is not necessary to overlap one pressed strip with the next.
 - No revolutions are counted while the roller is manoeuvring into position at the start of each strip.
 - Calculate the cost of hiring Roller 1 to press the 1 km stretch of road.
 - Repeat parts **b** and **c** for Roller 2.
-
- Assume that each strip rolled must now overlap the previous pressed strip by 10 cm. Determine the total number of revolutions required for each of the two rollers under these conditions.
 - Compare and comment on the cost of hiring the rollers if:
 - no overlap is required between strips
 - a 10 cm overlap is required between strips.

- g** Summarise your results in a table like the one below, and decide which roller should be hired and why.

Roller	Surface area of 1 revolution	Number of revolutions needed for road with no overlap	Cost of hiring with no overlap	Number of revolutions needed for road with 10 cm overlap	Cost of hiring with 10 cm overlap
1					
2					

Extension question

- a** If the overlap is changed to 0.5 m instead, which roller is the cheapest to hire? Give reasons and show calculations.



- 1 These towers are made by stacking cubes. How many cubes are needed in each case?

a

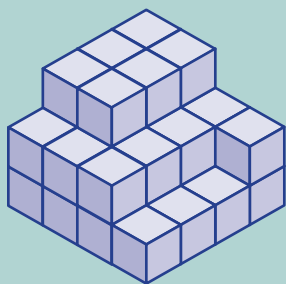

b

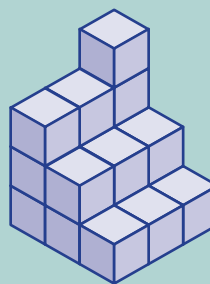

- 2 A large cube of side length 4 cm is painted then cut into 64 single 1 cm cubes. How many 1 cm cubes are not painted on any face?

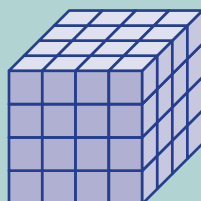

- 3 To the nearest metre, how far will a wheel of diameter 1 m travel after 100 revolutions?
- 4 A goat is tethered to the centre of one side of a shed with a 10 m length of rope. In what area of grass can the goat graze?

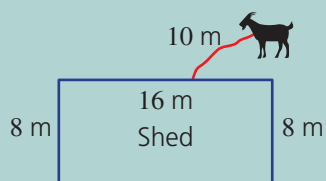

- 5 A circle of radius 10 cm has a hole cut out of its centre to form a ring. Find the radius of the hole if the remaining area is 50% of the original area. Round to one decimal place.

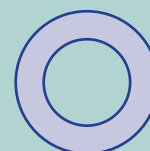

- 6 Here is one net for a cube. How many different nets are possible? Do not count nets that can be rotated or reflected (flipped) to give the same net.

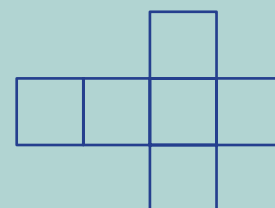

- 7 A 100 m^2 factory flat roof feeds all the water collected into a rainwater tank. If there is 1 mm of rainfall, how many litres of water go into the tank?

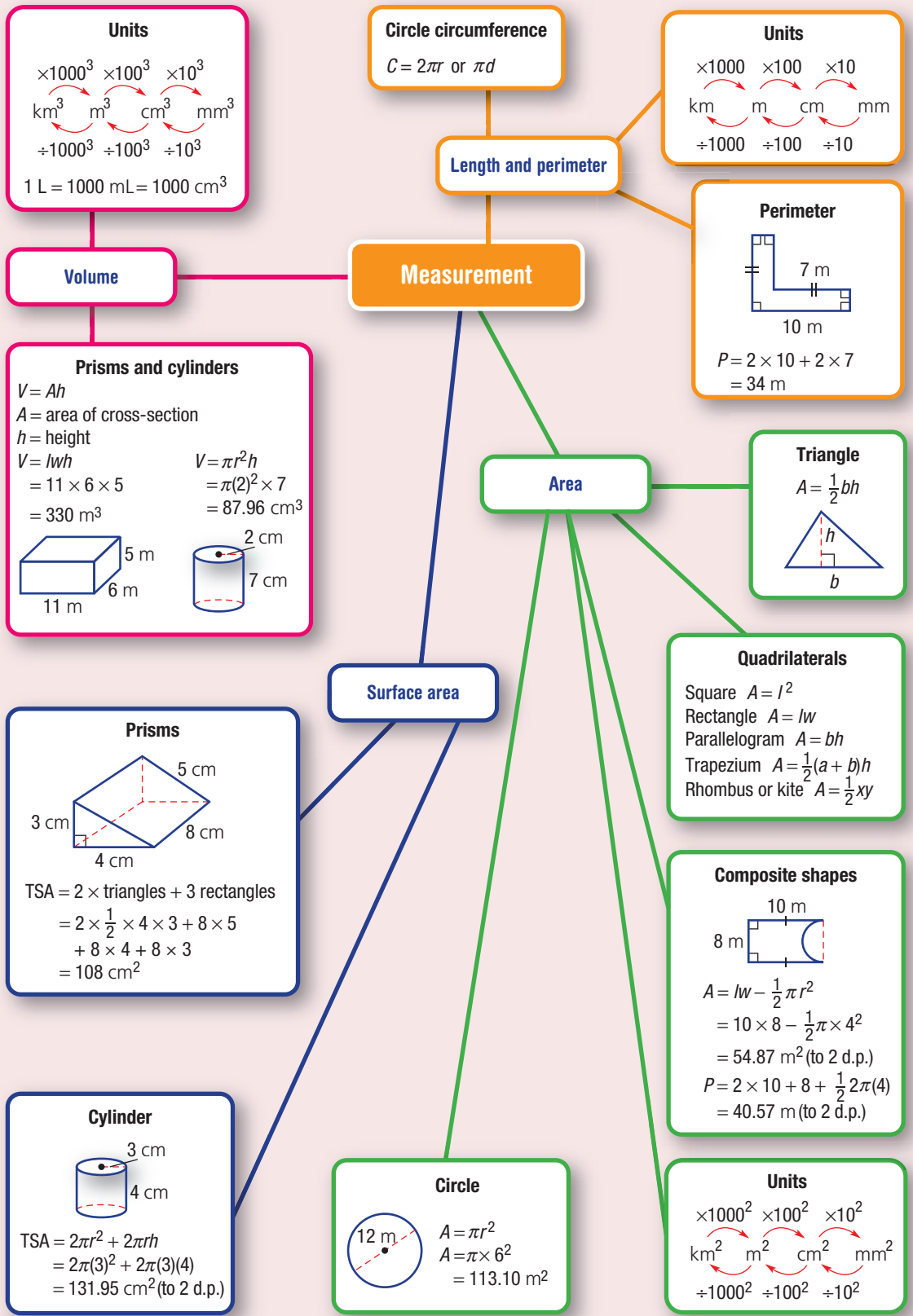

Chapter checklist

A version of this checklist that you can print out and complete can be downloaded from your Interactive Textbook.

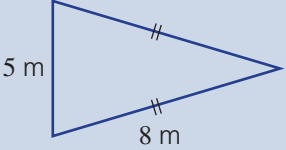
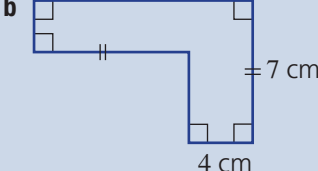
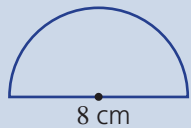
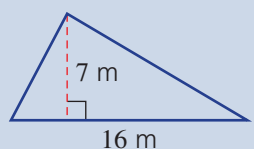
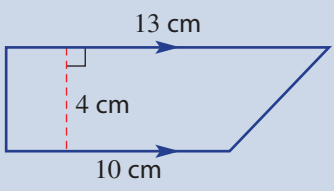
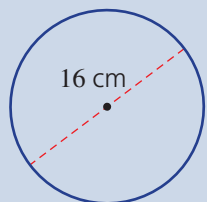
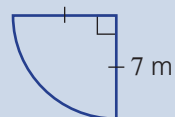
6A	<p>1 I can convert between metric units of length. e.g. Convert these measurements to the units shown in the brackets. a 9.2 cm (mm) b 61 000 cm (m)</p>	✓
6A	<p>2 I can find the perimeter of basic shapes including composite shapes. e.g. Find the perimeter of these shapes.</p> <p>a </p> <p>b </p>	
6B	<p>3 I can find the circumference of a circle. e.g. Find the circumference of a circle with a diameter of 5 m, correct to two decimal places.</p>	
6B	<p>4 I can find the perimeter of a semicircle or a quadrant. e.g. Find the perimeter of this semicircle correct to two decimal places.</p>	
6C	<p>5 I can convert between metric units of area. e.g. Convert these measurements to the units shown in the brackets. a 5.32 cm² (mm²) b 728 000 cm² (m²)</p>	
6C	<p>6 I can find the area of rectangles, triangles and parallelograms. e.g. Find the area of this triangle.</p>	
6C	<p>7 I can find the area of rhombuses and trapeziums. e.g. Find the area of this trapezium.</p>	
6D	<p>8 I can find the area of a circle. e.g. Find the area of this circle correct to two decimal places.</p>	
6D	<p>9 I can find the area of a quadrant or semicircle. e.g. Find the area of this quadrant correct to two decimal places.</p>	



Chapter checklist

6E

10 I can find the perimeter and area of simple composite shapes.

e.g. Find the perimeter and area of this composite shape correct to two decimal places.

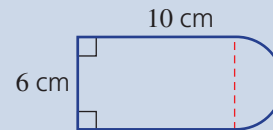

6F

11 I can find the total surface area of a rectangular prism.

e.g. Find the total surface area of this rectangular prism.

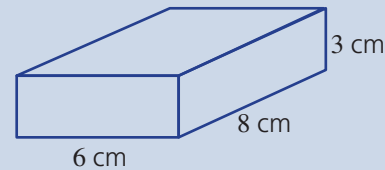

6F

12 I can find the total surface area of a triangular prism.

e.g. Find the total surface area of this triangular prism.

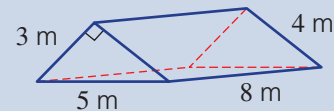

6G

13 I can find the total surface area of a cylinder.

e.g. Find the total surface area of this cylinder correct to two decimal places.

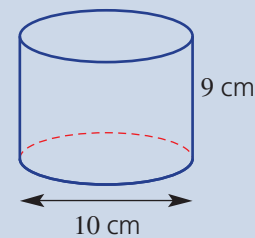

6G

14 I can find the total surface area of a cylindrical portion.

e.g. Find the total surface area of this half cylinder correct to two decimal places.

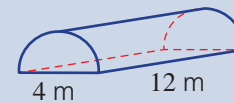

6H

15 I can convert between metric units of volume.

e.g. Convert these measurements to the units shown in the brackets.

a 0.003 m^3 (cm^3) **b** $640\,000 \text{ mm}^3$ (cm^3)

6H

16 I can find the volume of a rectangular prism.

e.g. Find the volume of this rectangular prism.

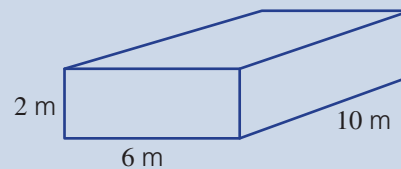

6H

17 I can find the volume of a triangular prism.

e.g. Find the volume of this triangular prism.

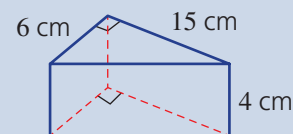

6I

18 I can find the volume of a cylinder.

e.g. Find the volume of this cylinder correct to two decimal places.

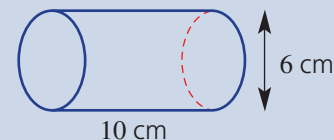

6I

19 I can find the capacity of a cylinder giving an answer in L or mL.

e.g. Find the volume of this cylinder in litres correct to the nearest litre.

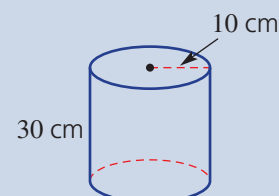

Short-answer questions

6A/6C/6H 1 Convert the following measurements into the units given in brackets.

a 3.8 m (cm)

b 1.27 km (m)

c 48 mm (cm)

d 273 mm² (cm²)

e 5.2 m² (cm²)

f 0.01 m³ (cm³)

g 53 100 mm³ (cm³)

h 3100 mL (L)

i 0.043 L (mL)

j 2.83 kL (L)

k 4000 cm³ (L)

l 1 m³ (L)

6A 2 Find the perimeter of each of the following shapes.

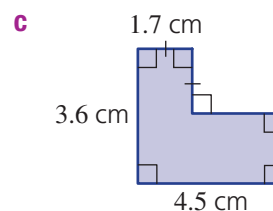
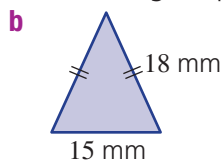
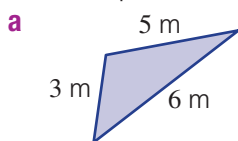

6C 3 Find the area of each of the following plane figures.

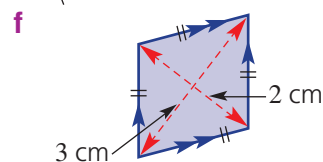
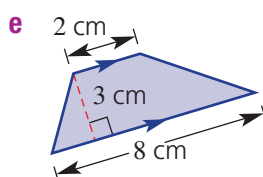
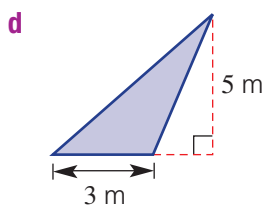
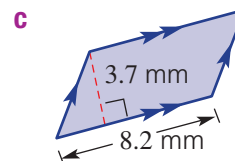
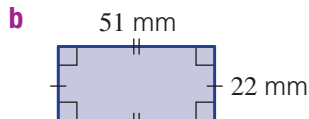
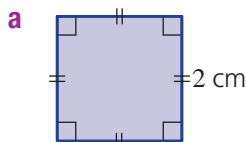

6E 4 Inside a rectangular lawn area of length 10.5 m and width 3.8 m, a new garden bed is to be constructed. The garden bed is to be the shape of a triangle with base 2 m and height 2.5 m. Find:



a the area of the garden bed

b the area of the lawn remaining around the garden bed.

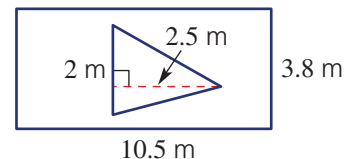

- 6B/6D** 5 Find the area and circumference/perimeter of each of the following shapes correct to two decimal places.

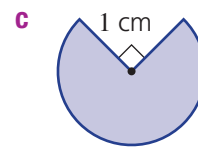
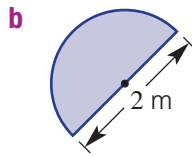
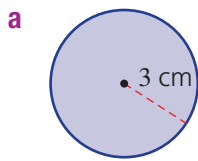

- 6E** 6 Find the perimeter and area of each of the following composite shapes correct to two decimal places.

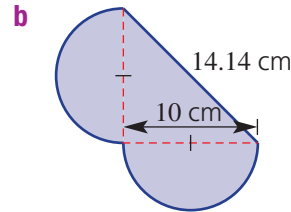
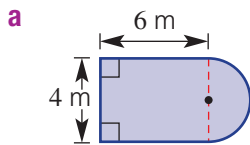

- 6F** 7 Find the total surface area of each of the following solid objects.

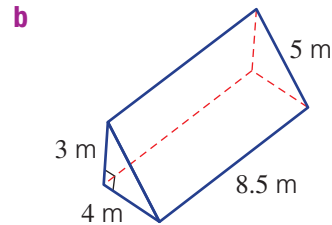
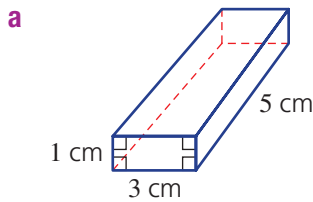

- 6G** 8 Find the total surface area of each of these cylinders, correct to two decimal places.

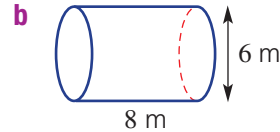
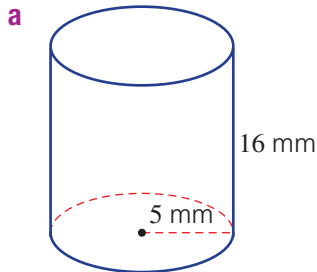

- 6H/6I** 9 Find the volume of each of these solid objects, rounding to two decimal places where necessary.

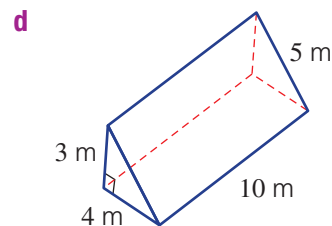
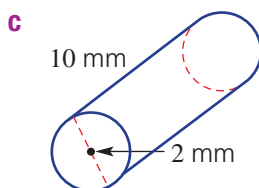
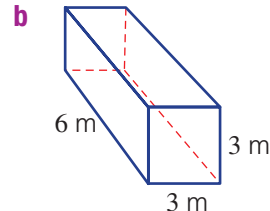
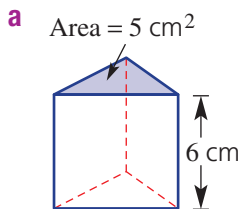

Multiple-choice questions

- 6A/6C** 1 If the area of a square field is 25 km^2 , the length of one of its sides is:
A 10 km **B** 5 km **C** 4 km **D** 50 km **E** 25 km

- 6C** 2 If $1 \text{ m}^2 = 100^2 \text{ cm}^2$, 2.7 m^2 is the same as:
A 270 cm^2 **B** 0.0027 km^2 **C** $27\,000 \text{ cm}^2$ **D** 2700 mm^2 **E** 27 cm^2

- 6A** 3 The perimeter of this shape is:
A 21 cm **B** 14 cm **C** 24 cm
D 20 cm **E** 22 cm

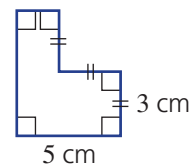

- 6C** 4 A parallelogram has area 10 m^2 and base 5 m. Using $A = bh$, its perpendicular height is:
A 50 m **B** 2 m **C** 50 m^2
D 2 m^2 **E** 0.5 m

- 6E** 5 This composite shape could be considered as a rectangle with an area in the shape of a square removed. The shape's area is:
A 16 km^2 **B** 12 km^2 **C** 20 km^2
D 24 km^2 **E** 6 km^2

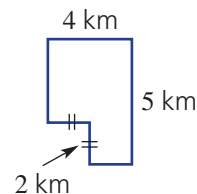

- 6B** 6 A semicircular goal area has diameter 20 m. Its perimeter, correct to the nearest metre, is:
A 41 m **B** 36 m **C** 83 m
D 51 m **E** 52 m

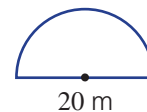

- 6F** 7 The surface area of the rectangular prism shown is:
A 30 m^2 **B** 62 m^2 **C** 31 m^2
D 60 m^2 **E** 100 m^2

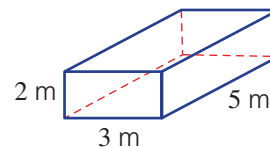

- 6G** 8 The area of the *curved surface only* of a cylinder with radius 5 mm and height 12 mm is closest to:
A 534 mm^2 **B** 94 mm^2 **C** 188 mm^2
D 754 mm^2 **E** 377 mm^2

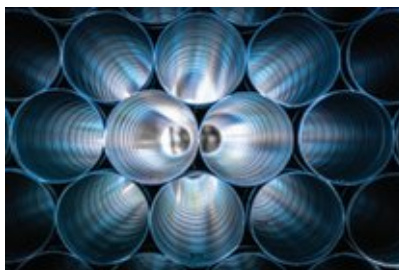
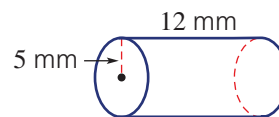

- 6H** 9 A prism's cross-sectional area is 100 m^2 . If its volume is 6500 m^3 , the prism's total height would be:
A 0.65 m **B** 650 000 m **C** 65 m **D** 6.5 m **E** 650 m

- 6I** 10 The volume of a cylinder with radius 3 cm and height 10 cm is closest to:
A 188 cm^2 **B** 251 cm **C** 141 cm^3 **D** 94 cm^3 **E** 283 cm^3



Extended-response questions

-  **1** A kindergarten teacher collects some blocks of wood for a painting activity. Each block is a rectangular prism, as shown.
- Find the volume of each block.
 - Find the total outside area to be painted for each block.
 - If the paint costs \$2.50 per 100 cm^2 , find the cost of painting 10 blocks.
 - Another wood block is a cylinder with radius 3 cm and height 9 cm. Compared to the rectangular block:
 - does it have a greater volume?
 - does it have a greater surface area?

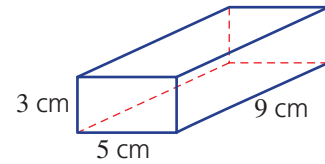

-  **2** An office receives five new desks with a bench shape made up of a rectangle and quarter circle as shown. The edge of the bench is lined with a rubber strip at a cost of \$2.50 per metre.
- Find the length of the rubber edging strip for one desk, correct to two decimal places.
 - Find the total cost of the rubber strip for the five desks. Round to the nearest dollar.
- The manufacturer claims that the desk top area space is more than 1.5 m^2 .
- Is the manufacturer's claim correct?

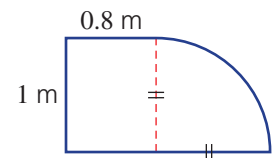

Chapter 7

Indices

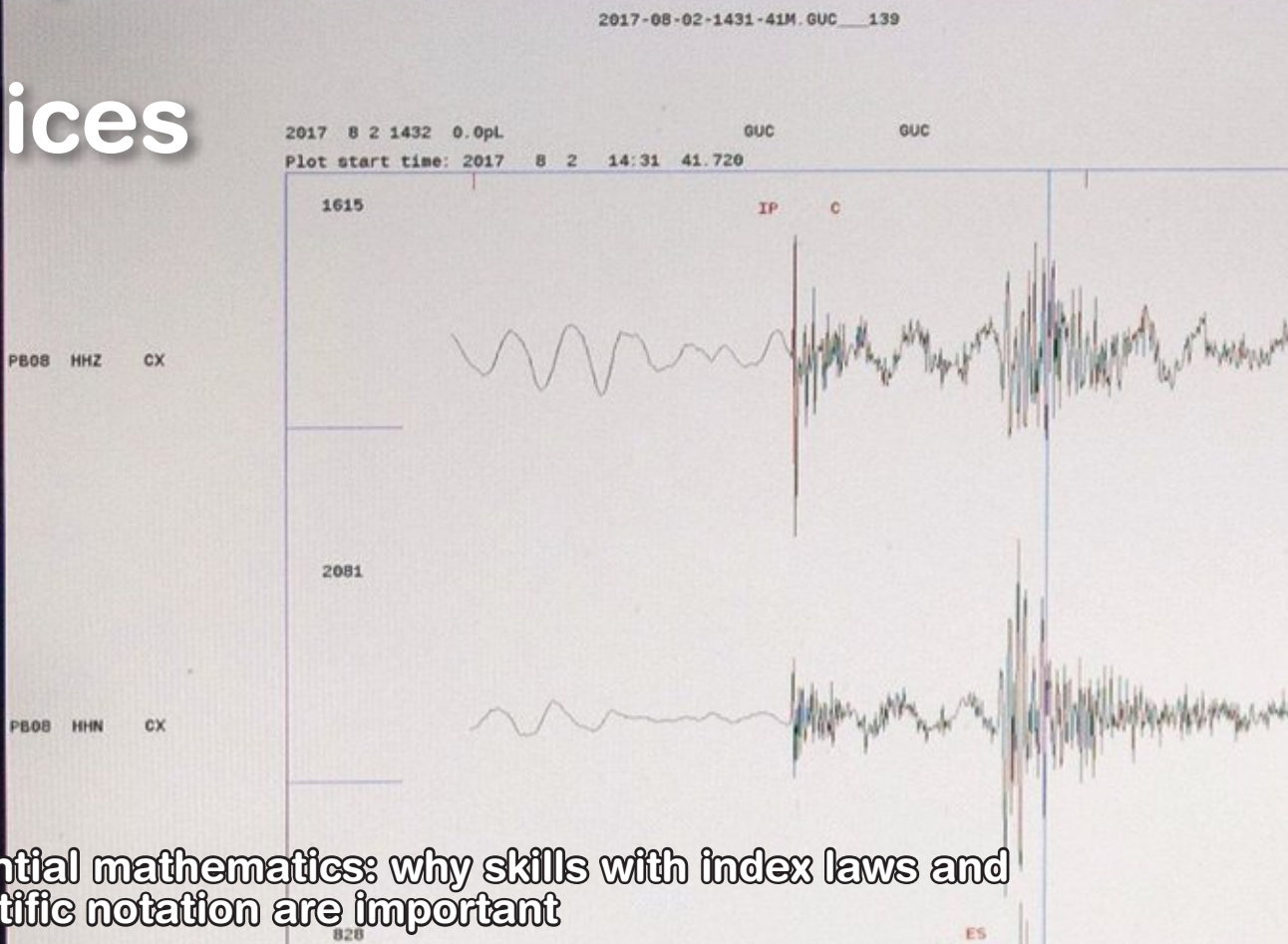

Essential mathematics: why skills with index laws and scientific notation are important

People who regularly use index laws and scientific notation include computer programmers, scientists, chemists, radiographers, financial planners, economists, astronomers, geologists and medical, electrical, sound and aerospace engineers.

Index laws and scientific notation are essential skills in numerous occupations, including when:

- scientists calculate the shaking intensity of earthquakes and the loudness of sound;
- food scientists predict the time for a food bacteria population to reach food-poisoning levels;
- accountants and financial advisors calculate the possible future values of an investment or the amount remaining of a debt;
- chemists determine the acidity of swimming pool water which needs enough chlorine to kill bacteria but must remain comfortable for the swimmers;
- sound engineers design music synthesisers that electronically reproduce the vibrations that make sound;
- medical scientists calculate the decay time of the radioactive isotopes that are injected for disease diagnosis.

In this chapter

- 7A Index notation (**Consolidating**)
- 7B Index laws 1 and 2
- 7C Index law 3 and the zero power
- 7D Index laws 4 and 5
- 7E Negative indices ★
- 7F Scientific notation
- 7G Scientific notation using significant figures

Australian Curriculum

NUMBER AND ALGEBRA

Real numbers

Apply index laws to numerical expressions with integer indices (ACMNA209)

Express numbers in scientific notation (ACMNA210)

Patterns and algebra

Extend and apply the index laws to variables, using positive integer indices and the zero index (ACMNA212)

MEASUREMENT AND GEOMETRY

Using units of measurement

Investigate very small and very large time scales and intervals (ACMMG219)

© Australian Curriculum, Assessment and Reporting Authority (ACARA)

Online resources

A host of additional online resources are included as part of your Interactive Textbook, including HOTmaths content, video demonstrations of all worked examples, auto-marked quizzes and much more.

1 Draw a factor tree for 36 and then write 36 as a product of prime factors.

- 2 a** List the factors of 24.
b List the factors of 45.
c List the prime factors of 24.
d List the prime factors of 45.

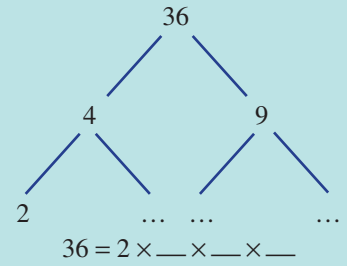

3 Write each of the following in index form (as a power; e.g. 6^4).

- a** $7 \times 7 \times 7$
b $5 \times 5 \times 2 \times 2 \times 2$
c $(3 \times 3 \times 3 \times 3) \div (3 \times 3)$
d $(4 \times 4 \times 4) \div (4 \times 4)$

4 Write each of the following as 2 raised to a single power.

- a** $2^2 \times 2$ **b** $2^4 \times 2^2$ **c** $2^3 \times 2^2$

5 Evaluate:

- a** 5^2 **b** 10^2 **c** 1^4 **d** 5^1 **e** 4^0

6 Write each of the following in expanded form and evaluate.

- a** 3×2^2 **b** 4×3^2 **c** 5×2^3 **d** 3×10^4

7 Simplify the following by removing brackets.

- a** $(3^2)^2$ **b** $(2^4)^3$ **c** $(-3)^2$

8 Write each of these fractions as decimals.

- a** $\frac{3}{1000}$ **b** $\frac{4}{100}$ **c** $\frac{2}{1\,000\,000}$ **d** $\frac{8}{10\,000}$

9 Round the following to two decimal places.

- a** 3.732 **b** 24.6174 **c** 18.3654 **d** 4.3971

10 State the place value of the 4 in each of these numbers.

- a** 246 **b** 0.0043 **c** 4 320 000 **d** 32.48

11 State the number of significant figures in each of the following.

- a** 23.102 **b** 30.05 **c** 0.0012 **d** 6001

12 Complete the following.

- a** $3.8 \times 10 =$ _____
b $2.31 \times 1000 =$ _____
c $17.2 \div 100 =$ _____
d $0.18 \div 100 =$ _____
e $3827 \div$ _____ $= 3.827$
f $6.49 \times$ _____ $= 64\,900$

7A Index notation

CONSOLIDATING

Learning intentions

- To understand index notation and know that it is a shorthand way of writing multiplication of the same base
- To be able to convert between expanded form and index form
- To be able to evaluate expressions given in index form
- To be able to express a number as a product of prime factors

Key vocabulary: index form, expanded form, power, exponent, base, index, prime, factor, substitution

When a product has the same number multiplied by itself over and over, index notation can be used to write a simpler expression. For example, $5 \times 5 \times 5$ can be written as 5^3 and $x \times x \times x \times x \times x$ can be written as x^5 . The expression 5^3 is a power and we can say '5 to the power of 3'. The 5 is called the base and the 3 is the index, power or exponent. Numbers written with indices are common in mathematics and can be applied to many types of problems.

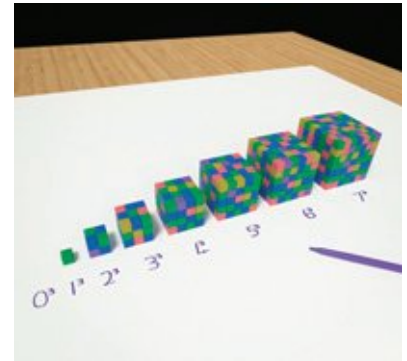

→ Lesson starter: Who has the most?

A person offers you one of two prizes.

- Which offer would you take?
- Try to calculate the final amount for prize B.
- How might you use index notation to help calculate the value of prize B?
- How can a calculator help to find the amount for prize B using the power button \square^{\square} ?



Key ideas

- When a number is multiplied by itself many times, that product can be written using **index form**. For example,

$$\begin{array}{c}
 \text{Expanded form} \quad \text{Index form} \\
 \underbrace{2 \times 2 \times 2 \times 2 \times 2}_{\text{Expanded form}} = \underbrace{2^5}_{\text{Index form}} = 32 \\
 \begin{array}{ccc}
 \text{base} & \text{index} & \text{basic numeral} \\
 \uparrow & \uparrow & \uparrow \\
 x \times x \times x \times x = x^4 & &
 \end{array} \\
 \begin{array}{cc}
 \text{base} & \text{index} \\
 \uparrow & \uparrow \\
 & &
 \end{array}
 \end{array}$$

- The **base** is the factor in the product.
- The **index** is the number of times the factor (base number) appears.
 - 2^5 reads '2 to the **power** of 5'.

7A

- Prime factorisation involves writing a number as a product of its prime factors.
 - A prime number has only two factors: 1 and itself.

Prime factorisation can be completed using a factor tree or repeated division.
For example,

Factor tree

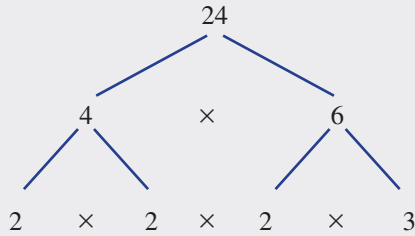

Repeated division

$$\begin{array}{r|l}
 2 & 24 \\
 2 & 12 \\
 2 & 6 \\
 3 & 3 \\
 & 1
 \end{array}$$

- To write 24 in prime factor form use indices: $24 = 2 \times 2 \times 2 \times 3$
 $= 2^3 \times 3$

- Note that $a^1 = a$. For example: $5^1 = 5$
 - 3^2 does *not* mean $3 \times 2 = 6$.

Exercise 7A

Understanding

1, 2–5(½)

1, 5

- a** The product $3 \times 3 \times 3 \times 3$ is called the _____ form of 81.

b 3^4 is called the _____ form of 81.

c 3^4 reads '3 to the _____ of 4'.

d In 3^4 the special name for the 3 is the _____ number.

e In 3^4 the special name for the 4 is the _____ number or _____.

f A _____ number has only two factors, itself and 1.

g Prime factorisation involves writing a number as a product of its _____ _____.
- Evaluate:

a 5^2	b 2^3	c 3^3	d $(-4)^2$
----------------	----------------	----------------	-------------------
- Write the number or pronumeral that is the base in these expressions.

a 3^7	b 6^4	c $(1.2)^5$	d $(-7)^3$
e $\left(\frac{2}{3}\right)^4$	f y^{10}	g w^6	h t^2
- Write the number that is the index in these expressions.

a 4^3	b 10^8	c $(-3)^7$	d $\left(\frac{1}{2}\right)^4$
e x^{11}	f $(xy)^{13}$	g $\left(\frac{x}{2}\right)^9$	h $(1.3x)^2$
- Write the prime factors of these numbers.

a 6	b 15	c 30	d 77
------------	-------------	-------------	-------------

Fluency

6–11(½)

6–11(½)



Example 1 Writing in expanded form

Write in expanded form:

a 5^4 **b** a^3 **c** $(xy)^4$ **d** $2a^3b^2$

Solution

Explanation

a $5^4 = 5 \times 5 \times 5 \times 5$

Factor 5 appears four times.

b $a^3 = a \times a \times a$

Factor a appears three times.

c $(xy)^4 = xy \times xy \times xy \times xy$

Factor xy appears four times.

d $2a^3b^2 = 2 \times a \times a \times a \times b \times b$

Factor a appears three times and factor b appears twice. Factor 2 only appears once.

Now you try

Write in expanded form:

a 6^3 **b** b^4 **c** $(mn)^2$ **d** $3x^2y$

6 Write each of the following in expanded form.

a 4^3 **b** 7^4 **c** 3^5 **d** 5^3
e a^4 **f** b^3 **g** x^3 **h** $(xp)^6$
i $(5a)^4$ **j** $(3y)^3$ **k** $4x^2y^5$ **l** $(pq)^2$
m $-3s^3t^2$ **n** $6x^3y^5$ **o** $5(yz)^6$ **p** $4(ab)^3$

Hint:

factor $\rightarrow a^5 \leftarrow$ number of repeats
 $a^5 = a \times a \times a \times a \times a$



Example 2 Expanding and evaluating

Write each of the following in expanded form and then evaluate.

a 5^3 **b** $(-2)^5$ **c** $\left(\frac{2}{5}\right)^3$

Solution

Explanation

a $5^3 = 5 \times 5 \times 5$
 $= 125$

Write in expanded form with 5 appearing three times and evaluate.

b $(-2)^5 = (-2) \times (-2) \times (-2) \times (-2) \times (-2)$
 $= -32$

Write in expanded form with -2 appearing five times and evaluate.

c $\left(\frac{2}{5}\right)^3 = \frac{2}{5} \times \frac{2}{5} \times \frac{2}{5}$
 $= \frac{8}{125}$

Write in expanded form.

Evaluate by multiplying numerators and denominators.

Now you try

Write each of the following in expanded form and then evaluate.

a 2^3 **b** $(-3)^3$ **c** $\left(\frac{3}{5}\right)^2$

7A

7 Write each of the following in expanded form and then evaluate.

a 6^2

b 2^4

c 3^5

d 12^1

e $(-2)^3$

f $(-1)^7$

g $(-3)^4$

h $(-5)^2$

i $\left(\frac{2}{3}\right)^3$

j $\left(\frac{3}{4}\right)^2$

k $\left(\frac{1}{6}\right)^3$

l $\left(\frac{5}{2}\right)^2$

m $\left(\frac{2}{-3}\right)^3$

n $\left(\frac{-3}{4}\right)^4$

o $\left(\frac{-1}{4}\right)^2$

p $\left(\frac{5}{-2}\right)^5$

Hint:

$-2 \times (-2) \times (-2)$

$= +4 \times (-2)$

$= -8$



Example 3 Writing in index form

Write each of the following in index form.

a $5 \times 5 \times 5 \times 5$

b $6 \times x \times x \times x \times x$

c $4 \times a \times 4 \times a \times 4 \times a$

Solution

Explanation

a $5 \times 5 \times 5 \times 5 = 5^4$

Factor 5 is repeated 4 times.

b $6 \times x \times x \times x \times x = 6x^4$

Factor x is repeated 4 times; 6 appears only once.

$$\begin{aligned} \text{c } 4 \times a \times 4 \times a \times 4 \times a \\ = 4 \times 4 \times 4 \times a \times a \times a \\ = 4^3 a^3 \end{aligned}$$

Group the factors of 4 together and the factors of a together.

Write in index form.

Now you try

Write each of the following in index form.

a $9 \times 9 \times 9$

b $2 \times a \times a$

c $11 \times b \times 11 \times b \times b$

8 Write each of the following in index form.

a $3 \times 3 \times 3$

b $8 \times 8 \times 8 \times 8 \times 8 \times 8$

c $y \times y$

d $3 \times x \times x \times x$

e $4 \times c \times c \times c \times c \times c$

f $5 \times 5 \times 5 \times d \times d$

g $x \times x \times y \times y \times y$

h $7 \times b \times 7 \times b \times 7$

Hint: The index is the number of times the factor appears.



Example 4 Writing in index form with fractions

Write each of the following in index form.

a $\frac{3}{4} \times \frac{3}{4} \times \frac{3}{4}$

b $\frac{3}{7} \times \frac{3}{7} \times \frac{4}{5} \times \frac{4}{5} \times \frac{4}{5}$

Solution

Explanation

a $\frac{3}{4} \times \frac{3}{4} \times \frac{3}{4} = \left(\frac{3}{4}\right)^3$

The fraction $\frac{3}{4}$ appears 3 times.

b $\frac{3}{7} \times \frac{3}{7} \times \frac{4}{5} \times \frac{4}{5} \times \frac{4}{5} = \left(\frac{3}{7}\right)^2 \times \left(\frac{4}{5}\right)^3$

$\frac{3}{7}$ appears twice and $\frac{4}{5}$ three times.

Now you try

Write each of the following in index form.

a $\frac{5}{7} \times \frac{5}{7} \times \frac{5}{7} \times \frac{5}{7}$

b $\frac{2}{5} \times \frac{4}{7} \times \frac{2}{5} \times \frac{4}{7} \times \frac{4}{7}$

9 Write each of the following in index form.

a $\frac{2}{3} \times \frac{2}{3} \times \frac{2}{3} \times \frac{2}{3}$

b $\frac{3}{5} \times \frac{3}{5} \times \frac{3}{5} \times \frac{3}{5} \times \frac{3}{5}$

c $\frac{4}{7} \times \frac{4}{7} \times \frac{1}{5} \times \frac{1}{5} \times \frac{1}{5} \times \frac{1}{5}$

d $\frac{7x}{9} \times \frac{7x}{9} \times \frac{y}{4} \times \frac{y}{4} \times \frac{y}{4}$

**Example 5 Writing in index form with a combination of pronumerals**

Write each of the following in index form.

a $8 \times a \times a \times 8 \times b \times b \times a \times b$

b $3a \times 2m \times 3a \times 2m$

c $4am(4am)(4am)$

Solution**Explanation**

a $8 \times a \times a \times 8 \times b \times b \times a \times b$
 $= 8 \times 8 \times a \times a \times a \times b \times b \times b$
 $= 8^2 a^3 b^3$

Group the numerals and like pronumerals and write in index form.

 $64a^3b^3$ or $64(ab)^3$ are alternative answers.

b $3a \times 2m \times 3a \times 2m$
 $= 2 \times 2 \times 3 \times 3 \times a \times a \times m \times m$
 $= 2^2 3^2 a^2 m^2$

Rearrange so like factors are grouped together and write in index form.

 $36a^2m^2$ or $36(am)^2$ are alternative answers.

c $4am(4am)(4am)$
 $= 4 \times 4 \times 4 \times a \times a \times a \times m \times m \times m$
 $= 4^3 a^3 m^3$

Rearrange and write in index form.

 $64a^3m^3$ or $64(am)^3$ are alternative answers.**Now you try**

Write each of the following in index form.

a $7 \times x \times x \times 7 \times y \times 7 \times x \times y$

b $2m \times 7s \times 2m \times 7s \times 2m$

c $3ab(3ab)(3ab)(3ab)$

10 Write each of the following in index form.

a $3 \times x \times y \times x \times 3 \times x \times 3 \times y$ **b** $3x \times 2y \times 3x \times 2y$

c $4d \times 2e \times 4d \times 2e$ **d** $6by(6by)(6y)$

e $3pq(3pq)(3pq)(3pq)$ **f** $7mn \times 7mn \times mn \times 7$

Hint: First rearrange the factors with numbers first, then form groups of like bases.



7A

Example 6 Finding the prime factor form

Express 48 as a product of prime factors in index form. Prime numbers are divisible only by 1 and themselves.

Solution

Tree diagram method

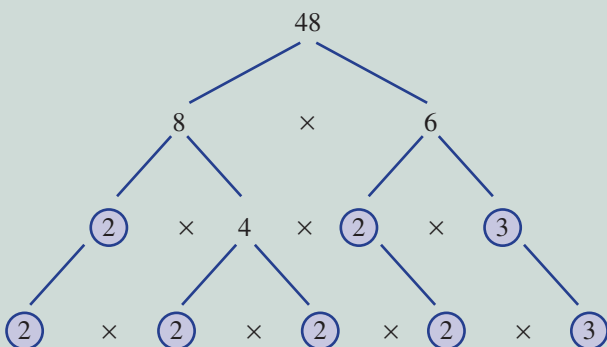

$$48 = 2 \times 2 \times 2 \times 2 \times 3$$

$$= 2^4 \times 3$$

Repeated division method

$$\begin{array}{r} 2 \overline{)48} \\ 2 \overline{)24} \\ 2 \overline{)12} \\ 2 \overline{)6} \\ 2 \overline{)3} \\ 3 \overline{)3} \\ \hline 1 \end{array}$$

$$48 = 2 \times 2 \times 2 \times 2 \times 3$$

$$= 2^4 \times 3$$

Explanation

Choose a pair of factors of 48; for example, 8 and 6.

Choose a pair of factors of 8; i.e. 2 and 4.

Choose a pair of factors of 6; i.e. 2 and 3.

Continue this process until the factors are all prime numbers.

Write the prime factors of 48.
Express in index notation.

Start by dividing by a prime number.

$$48 \div 2 = 24$$

$$24 \div 2 = 12$$

$$12 \div 2 = 6$$

$$6 \div 2 = 3$$

$$3 \div 3 = 1$$

Write prime factors in ascending order.

Express in index notation.

Now you try

Express 60 as a product of prime factors.

11 Express each of the following as a product of prime factors in index form.

a 10

b 8

c 144

d 75

e 147

f 500

Problem-solving and reasoning

12, 13

12–14(½)

12 Copy and fill in the missing numbers or symbols.

a $3 \times 3 \times a \times a \times a = 3^{\square} a^{\square}$

b $\square \times \square \times k \times k \times k = 5^2 k^{\square}$

c $\frac{2}{7} \times \frac{2}{7} \times \frac{2}{7} = \left(\frac{2}{7}\right)^{\square}$

d $3p^2q = 3 \times \square \times \square \times q$

e $(abc)^1 = a \square b \square c$

f $4ab^2 = \square \times (-2) \times \square \times \square \times b$



Example 7 Evaluating expressions in index form by using substitution

If $a = 5$, $b = 2$ and $c = -5$, evaluate these expressions.

a $(ab)^2$ **b** $\left(\frac{a}{c}\right)^3$ **c** $\left(\frac{b}{c}\right)^2$

Solution

Explanation

$$\begin{aligned} \mathbf{a} \quad (ab)^2 &= (5 \times 2)^2 \\ &= 10^2 \\ &= 10 \times 10 \\ &= 100 \end{aligned}$$

Replace a with 5 and b with 2. Include the \times sign. $5 \times 2 = 10$
Base of 10 appears twice.

$$\begin{aligned} \mathbf{b} \quad \left(\frac{a}{c}\right)^3 &= \left(\frac{5}{-5}\right)^3 \\ &= (-1)^3 \\ &= -1 \times (-1) \times (-1) \\ &= -1 \end{aligned}$$

Replace a with 5 and c with -5 .
 $5 \div (-5) = -1$
 $-1 \times (-1) = +1$, $+1 \times (-1) = -1$

$$\begin{aligned} \mathbf{c} \quad \left(\frac{b}{c}\right)^2 &= \left(\frac{2}{-5}\right)^2 \\ &= \frac{2}{-5} \times \frac{2}{-5} \\ &= \frac{4}{25} \end{aligned}$$

Replace b with 2 and c with -5 .
Write in expanded form.
 $2 \times 2 = 4$, $-5 \times (-5) = 25$

Now you try

If $a = 3$, $b = -2$ and $c = 7$, evaluate these expressions.

a $(ab)^2$ **b** $\left(\frac{b}{a}\right)^3$ **c** $ab^2 + ac$

13 If $a = 3$, $b = 2$ and $c = -3$, evaluate these expressions.

a $(ab)^2$ **b** $(bc)^3$ **c** $\left(\frac{a}{c}\right)^4$ **d** $\left(\frac{b}{c}\right)^3$
e $(abc)^1$ **f** $c^2 + ab$ **g** ab^2c **h** c^2ab^3

Hint:
 $abc = a \times b \times c$



14 Find the missing number.

a $3^{\square} = 81$ **b** $2^{\square} = 256$ **c** $\square^3 = 125$
d $\square^5 = 32$ **e** $\square^3 = -64$ **f** $\square^7 = -128$
g $\square^3 = \frac{1}{8}$ **h** $\left(\frac{2}{3}\right)^{\square} = \frac{16}{81}$ **i** $\left(\frac{\square}{4}\right)^3 = \frac{1}{64}$

Hint: For part **a**, ask 'How many times should 3 appear so that the product is 81?'



7A



Splitting cells

15



15 Certain bacteria cells split in 2 every 1 minute. New cells also continue splitting in the same way. So, after each minute, the number of bacteria cells has doubled.

- a Copy and complete this table showing the number of bacteria after each minute for 10 minutes.

Time in minutes	Number of bacteria	Number in index form
0	1	2^0
1	$1 \times 2 = 2$	2^1
2	$2 \times 2 = 4$	2^2
3	$2 \times 2 \times 2 = 8$	2^3

- b How long will it take for 1 cell to divide into:
 i 4 cells? ii 16 cells? iii 64 cells?
- c A single cell is set aside to divide for 24 minutes. Use index form to quickly find how many cells there will be after this time.



7B Index laws 1 and 2

Learning intentions

- To know the index laws for multiplication and division involving a common base
- To be able to apply the index laws for multiplication and division to simplify expressions

Key vocabulary: index law, base

When multiplying or dividing numbers with the same base, index laws can be used to simplify the expression.

Consider $5^{18} \times 5^{10}$:

$$\begin{aligned} \text{Using expanded form: } 5^{18} \times 5^{10} &= \overbrace{5 \times 5 \times 5 \times \dots \times 5}^{18 \text{ factors of } 5} \times \overbrace{5 \times 5 \times 5 \times \dots \times 5}^{10 \text{ factors of } 5} \\ &= \overbrace{5 \times 5 \times 5 \times \dots \times 5}^{18 + 10 \text{ factors of } 5} \\ &= 5^{18+10} \\ &= 5^{28} \end{aligned}$$

So the total number of factors of 5 is $18 + 10 = 28$.

$$\begin{aligned} \text{Also } 5^{18} \div 5^{10} &= \frac{\overbrace{5 \times 5 \times \dots \times 5}^{18 \text{ factors of } 5}}{\underbrace{\cancel{5} \times \dots \times \cancel{5} \times \cancel{5}}_{10 \text{ factors of } 5}} \\ &= 5^{18-10} \\ &= 5^8 \end{aligned}$$

So the total number of factors of 5 is $18 - 10 = 8$.

→ Lesson starter: Discovering laws 1 and 2

Consider the two expressions $2^3 \times 2^5$ and $6^8 \div 6^6$.

$$\begin{aligned} \text{Complete this working. } 2^3 \times 2^5 &= 2 \times \square \times \square \times 2 \times \square \times \square \times \square \times \square \\ &= 2^{\square} \end{aligned}$$

$$\begin{aligned} 6^8 \div 6^6 &= \frac{6 \times \square \times \square \times \square \times \square \times \square \times \square \times \square}{6 \times \square \times \square \times \square \times \square \times \square} \\ &= \frac{6 \times 6}{1} \\ &= 6^{\square} \end{aligned}$$

- What do you notice about the given expression and the answer in each case? Can you express this as a rule or law in words?
- Repeat the type of working given above and test your laws on these expressions.
 - $3^2 \times 3^7$
 - $4^{11} \div 4^8$

7B

Key ideas

- Index law 1:** $a^m \times a^n = a^{m+n}$
 - When multiplying terms with the same base, add the powers.
For example, $7^3 \times 7^2 = 7^{3+2} = 7^5$
- Index law 2:** $a^m \div a^n = \frac{a^m}{a^n} = a^{m-n}$
 - When dividing terms with the same base, subtract the powers.
For example, $8^5 \div 8^3 = \frac{8^5}{8^3} = 8^{5-3} = 8^2$

Exercise 7B

Understanding

1–4

4

1 Write the missing words.

- a** Index law 1 states that if you _____ two terms with the same _____ you _____ the powers.
b Index law 2 states that if you _____ two terms with the same _____ you _____ the powers.

2 Copy and complete to give an answer in index form.

a $3^2 \times 3^4 = 3 \times \square \times 3 \times \square \times \square \times \square$
 $= 3^\square$

b $k^3 \times k^2 = k \times \square \times \square \times \square \times \square$
 $= k^\square$

Hint: The index shows how many times the factor should appear.



3 Copy and complete to give an answer in index form.

a $5^5 \div 5^3 = \frac{5 \times \square \times \square \times \square \times \square}{5 \times \square \times \square}$
 $= 5^\square$

b $a^6 \div a^2 = \frac{a \times \square \times \square \times \square \times \square \times \square}{\square \times \square}$
 $= a^\square$

Hint: Show cancelling,
 e.g. $\frac{5 \times \cancel{5^1} \times \cancel{5^1}}{1 \times \cancel{5} \times \cancel{5^1}}$



4 Copy and complete.

a $6^5 \times 6^7 = 6^{\square+\square} = 6^\square$

b $a^{13} \times a^2 = a^{\square+\square} = a^\square$

c $5^{12} \div 5^4 = 5^{\square-\square} = 5^\square$

d $\frac{m^{16}}{m^2} = m^{\square-\square} = m^\square$

Hint: When dividing, subtract the indices.



Fluency

5–8(½)

5–8(½)



Example 8 Using laws 1 and 2 with a numerical base

Simplify, giving your answer in index form.

a $3^6 \times 3^4$ **b** $4^5 \times 4$ **c** $7^9 \div 7^5$ **d** $6^8 \div 6$

Solution

Explanation

a $3^6 \times 3^4 = 3^{6+4}$
 $= 3^{10}$

$$a^m \times a^n = a^{m+n}$$

Add powers: $6 + 4 = 10$. The base 3 is unchanged.

b $4^5 \times 4 = 4^{5+1}$
 $= 4^6$

$$4 = 4^1$$

Add powers: $5 + 1 = 6$. The base 4 is unchanged.

c $7^9 \div 7^5 = 7^{9-5}$
 $= 7^4$

$$a^m \div a^n = a^{m-n}$$

Subtract powers: $9 - 5 = 4$. The base 7 is unchanged.

d $6^8 \div 6 = 6^{8-1}$
 $= 6^7$

$$6 = 6^1$$

Subtract powers: $8 - 1 = 7$. The base 6 is unchanged.

Now you try

Simplify, giving your answer in index form.

a $2^4 \times 2^7$ **b** $7^5 \times 7$ **c** $11^{12} \div 11^4$ **d** $5^{10} \div 5$

5 Simplify, giving your answers in index form.

a $2^4 \times 2^3$

b $5^6 \times 5^3$

c $7^2 \times 7^4$

d $8^9 \times 8$

e $3^4 \times 3^4$

f $6^5 \times 6^9$

g $3^7 \div 3^4$

h $6^8 \div 6^3$

i $5^4 \div 5$

j $10^6 \div 10^5$

k $9^9 \div 9^6$

l $(-2)^5 \div (-2)^3$

Hint:
Remember: $8 = 8^1$ 

Example 9 Using index law 1

Simplify each of the following using the first index law.

a $x^4 \times x^5 \times x^2$

b $x^3 y^4 \times x^2 y$

Solution

Explanation

a $x^4 \times x^5 \times x^2 = x^{4+5+2}$
 $= x^{11}$

Use law 1 to add the indices, since all terms have base x .

b $x^3 y^4 \times x^2 y = x^3 x^2 y^4 y$
 $= x^{3+2} y^{4+1}$
 $= x^5 y^5$

Regroup so like bases are together. Use law 1 to add the indices corresponding to each different base.
Recall that $y = y^1$.

Now you try

Simplify each of the following using the first index law.

a $a^3 \times a \times a^4$

b $m^2 n^3 \times mn^4$

7B

- 6 Simplify each of the following using the first index law.
- | | | |
|------------------------------------|--------------------------------------|------------------------------------|
| a $x^4 \times x^3$ | b $a^6 \times a^3$ | c $t^5 \times t^3$ |
| d $y \times y^4$ | e $d^2 \times d$ | f $y^2 \times y \times y^4$ |
| g $b \times b^5 \times b^2$ | h $q^6 \times q^3 \times q^2$ | i $a^2m^2 \times a^3m^2$ |
| j $k^3p^2 \times k^2p$ | k $x^2y^3 \times x^4y^5$ | l $m^5e^3 \times m^2e$ |

Hint: Check that the bases are the same before adding the indices.



Example 10 Using index law 2

Simplify $x^{10} \div x^2$ using the second index law.

Solution

$$\begin{aligned} x^{10} \div x^2 &= x^{10-2} \\ &= x^8 \end{aligned}$$

Explanation

Use law 2 to subtract the indices: $10 - 2 = 8$.
The base x is unchanged.

Now you try

Simplify $y^{11} \div y^5$ using the second index law.

- 7 Simplify each of the following using the second index law.

a $a^6 \div a^4$	b $x^5 \div x^2$	c $\frac{q^{12}}{q^2}$	d $\frac{d^7}{d^6}$
e $\frac{b^{10}}{b^5}$	f $\frac{d^9}{d^4}$	g $\frac{a^{14}}{a^7}$	h $\frac{y^{15}}{y^7}$

Hint:
Recall: $\frac{q^{12}}{q^2} = q^{12} \div q^2$



Example 11 Simplifying using index law 1 or 2

Simplify each of the following using the first or second index law.

a $3m^4 \times 2m^5$	b $12y^7 \div (4y^3)$	c $\frac{8a^6b^3}{12a^2b^2}$
-----------------------------	------------------------------	-------------------------------------

Solution

$$\begin{aligned} \mathbf{a} \quad 3m^4 \times 2m^5 &= 3 \times 2 \times m^4 \times m^5 \\ &= 6 \times m^{4+5} \\ &= 6m^9 \end{aligned}$$

$$\begin{aligned} \mathbf{b} \quad 12y^7 \div (4y^3) &= \frac{12y^7}{4y^3} \\ &= 3y^{7-3} \\ &= 3y^4 \end{aligned}$$

$$\begin{aligned} \mathbf{c} \quad \frac{8a^6b^3}{12a^2b^2} &= \frac{8}{12} \times \frac{a^6}{a^2} \times \frac{b^3}{b^2} \\ &= \frac{2}{3}a^4b \text{ or } \frac{2a^4b}{3} \end{aligned}$$

Explanation

Regroup with numbers first then like bases together. Multiply the numbers then use law 1 to add the indices of the base m .

$12 \div 4 = 3$
Use law 2 to subtract indices.

$\frac{8}{12} = \frac{2}{3}$ in simplest form.

Use law 2 to subtract the indices for each different base: $6 - 2 = 4$, $3 - 2 = 1$.

Recall: $b = b^1$.

Now you try

Simplify each of the following using the first or second index law.

a $4a^2 \times 5a^3$

b $20b^8 \div (5b)^3$

c $\frac{6x^4y^2}{8x^2y}$

8 Simplify, using the first two index laws.

a $7x^3y^3 \times x^4y^2$

b $3x^7y^3 \times x^2y$

c $5x^3y^5 \times xy^4$

d $xy^4z \times 4xy$

e $3m^3 \times 5m^2$

f $4e^4f^2 \times 2e^2f^2$

g $5c^4d \times 4c^3d$

h $9yz^2 \times 2yz^5$

i $9m^3 \div (3m^2)$

j $14x^4 \div (2x)$

k $5y^4 \div y^2$

l $6a^6 \div (2a^5)$

m $\frac{36m^7}{12m^2}$

n $\frac{5w^2}{25w}$

o $\frac{4a^4}{20a^3}$

p $\frac{7x^5}{63x}$

q $\frac{16x^8y^6}{12x^2y^3}$

r $\frac{6s^6t^3}{14s^5t}$

s $\frac{8m^5n^4}{6m^4n^3}$

t $\frac{5x^2y}{xy}$

Hint: Rearrange first, and group numbers and like bases together.

**Problem-solving and reasoning**

9–10(½)

9–12(½)

**Example 12 Combining index laws 1 and 2**

Simplify each of the following using the first two index laws.

a $x^2 \times x^3 \div x^4$

b $\frac{2a^3b \times 8a^2b^3}{4a^4b^2}$

Solution

a $x^2 \times x^3 \div x^4 = x^5 \div x^4$
 $= x$

b $\frac{2a^3b \times 8a^2b^3}{4a^4b^2} = \frac{2 \times 8 \times a^3a^2 \times bb^3}{4 \times a^4 \times b^2}$
 $= \frac{16}{4} \times \frac{a^5}{a^4} \times \frac{b^4}{b^2}$
 $= 4 \times a \times b^2$
 $= 4ab^2$

ExplanationUse law 1 to add the indices for $x^2 \times x^3$.Use law 2 to subtract the indices for $x^5 \div x^4$.

Rearrange the question with numbers first, then like bases grouped together.

$2 \times 8 = 16, a^3a^2 = a^{3+2} = a^5, bb^3 = b^{1+3} = b^4$

$\frac{16}{4} = 4, \frac{a^5}{a^4} = a^{5-4} = a^1 = a, \frac{b^4}{b^2} = b^{4-2} = b^2$

Now you try

Simplify each of the following using the first two index laws.

a $a^3 \times a^6 \div a^8$

b $\frac{3m^3n^2 \times 4mn^3}{2m^2n^3}$

9 Simplify each of the following using the first two index laws.

a $b^5 \times b^2 \div b$

b $y^5 \times y^4 \div y^3$

c $c^4 \div c \times c^4$

d $x^4 \times x^2 \div x^5$

e $\frac{t^4 \times t^3}{t^6}$

f $\frac{p^2 \times p^7}{p^3}$

g $\frac{d^5 \times d^3}{d^2}$

h $\frac{x^9 \times x^2}{x}$

i $\frac{3x^3y^4 \times 8xy}{6x^2y^2}$

j $\frac{9b^4}{2g^3} \times \frac{4g^4}{3b^2}$

Hint: Write pronumerals in alphabetical order.



7B

10 Simplify each of the following.

a $\frac{m^4}{n^2} \times \frac{m}{n^3}$

b $\frac{x}{y} \times \frac{x^3}{y}$

c $\frac{a^4}{b^3} \times \frac{b^6}{a}$

d $\frac{12a}{3c^3} \times \frac{6a^4}{4c^4}$

e $\frac{3f^2 \times 8f^7}{4f^3}$

f $\frac{4x^2b \times 9x^3b^2}{3xb}$

11 Write the missing number.

a $2^7 \times 2^{\square} = 2^{19}$

b $6^{\square} \times 6^3 = 6^{11}$

c $11^6 \div 11^{\square} = 11^3$

d $19^{\square} \div 19^2 = 19$

e $x^6 \times x^{\square} = x^7$

f $a^{\square} \times a^2 = a^{20}$

g $b^{13} \div b^{\square} = b$

h $y^{\square} \div y^9 = y^2$

i $\square \times x^2 \times 3x^4 = 12x^6$

j $15y^4 \div (\square y^3) = y$

k $\square a^9 \div (4a) = \frac{a^8}{2}$

l $13b^6 \div (\square b^5) = \frac{b}{3}$

12 Evaluate without using a calculator.

a $7^7 \div 7^5$

b $10^6 \div 10^5$

c $13^{11} \div 13^9$

d $2^{20} \div 2^{17}$

e $101^5 \div 101^4$

f $200^{30} \div 200^{28}$

g $7 \times 31^{16} \div 31^{15}$

h $3 \times 50^{200} \div 50^{198}$

Hint: Simplify using index laws first.



Areas and index notation

13

13 a Write the area of each of these shapes using index notation.

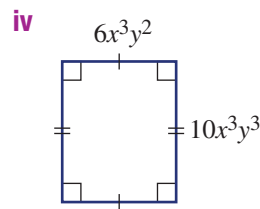
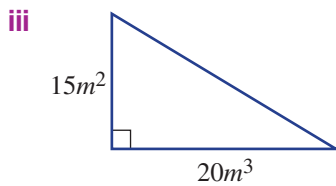
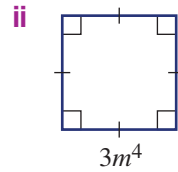
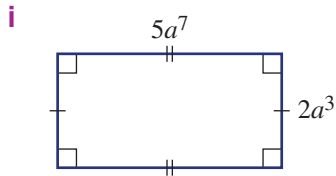

b Find the width of each of these shapes using index notation.

i Area = $24a^3m^2$

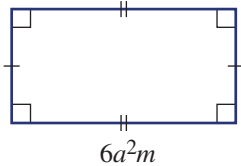

ii Area = $36x^2y^4$

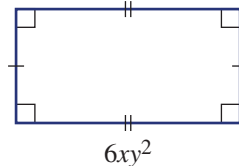

7C Index law 3 and the zero power

Learning intentions

- To know the index law for raising a power to another power
- To know the rule for the zero power
- To be able to simplify expressions using index laws 1, 2 and 3 and the zero power

Key vocabulary: index law, zero power

Sometimes we find that expressions already written in index form are raised to another power, such as $(2^3)^4$ or $(a^2)^5$.

Consider $(a^2)^5$.

$$\begin{aligned}(a^2)^5 &= \underbrace{a^2}_{a \times a} \times \underbrace{a^2}_{a \times a} \times \underbrace{a^2}_{a \times a} \times \underbrace{a^2}_{a \times a} \times \underbrace{a^2}_{a \times a} \\ &= a \times a \times a \times a \times a \times a \times a \times a \times a \times a \times a \\ &= a^{10}\end{aligned}$$

When a^2 appears 5 times there are a total of $5 \times 2 = 10$ factors of a . So when a^m appears n times, there will be a total of $m \times n = mn$ factors of a .

The power of 0 has a special property.

Consider $\frac{a^3}{a^3}$.

Simplify using expanded form: Simplify using index law 2:

$$\frac{a^3}{a^3} = \frac{\cancel{a}^1 \times \cancel{a}^1 \times \cancel{a}^1}{\cancel{a}_1 \times \cancel{a}_1 \times \cancel{a}_1} = 1$$

$$\frac{a^3}{a^3} = a^{3-3} = a^0$$

So $a^0 = 1$

Lesson starter: Discovering law 3 and the zero power

Use the expanded form of 5^3 to simplify $(5^3)^2$ as shown. $(5^3)^2 = 5 \times \square \times \square \times 5 \times \square \times \square = 5^\square$

- Repeat these steps to also simplify $(3^2)^4$ and $(x^4)^2$.
- What do you notice about the given expression and answer in each case? Can you express this as a law or rule in words?

Now copy and complete this table.

Index form	3^5	3^4	3^3	3^2	3^1	3^0
Basic numeral	243	81				

- What pattern do you notice in the basic numerals?
- What conclusion do you come to regarding 3^0 ?

7C

Key ideas

- Index law 3: $(a^m)^n = a^{m \times n} = a^{mn}$
 - When raising a term in index form to another power, retain the base and multiply the indices. For example: $(x^2)^3 = x^{2 \times 3} = x^6$.
 - A power outside brackets only applies to the expression inside those brackets. For example: $5(a^3)^2 = 5a^{3 \times 2} = 5a^6$.
- The **zero power**: $a^0 = 1$, where $a \neq 0$
 - Any term except 0 raised to the power of zero is 1. For example: $5^0 = 1$, $m^0 = 1$ and $(2a)^0 = 1$.

Exercise 7C

Understanding

1–4

4

1 Write the missing word or number in these sentences.

- a When raising a term or numbers in index form to another power, _____ the indices.
- b Any number (except 0) raised to the power 0 is equal to _____.

Hint: Choose from 0, 1, 2, *divide*, *add*, *subtract* or *multiply*.



2 Write the missing numbers in these tables.

a

Index form	2^6	2^5	2^4	2^3	2^2	2^1	2^0
Basic numeral	64	32					

b

Index form	4^5	4^4	4^3	4^2	4^1	4^0
Basic numeral	1024	256				

3 Copy and complete this working.

- a $(4^2)^3 = 4^2 \times 4^2 \times 4^2$
 $= (4 \times \square) \times (4 \times \square) \times (4 \times \square)$
 $= 4^\square$
- b $(12^3)^2 = 12^\square \times 12^\square$
 $= (12 \times \square \times \square) \times (12 \times \square \times \square)$
 $= 12^\square$
- c $(x^4)^2 = x^\square \times x^\square$
 $= (x \times \square \times \square \times \square) \times (x \times \square \times \square \times \square)$
 $= x^\square$
- d $(a^2)^5 = a^\square \times a^\square \times a^\square \times a^\square \times a^\square$
 $= (a \times \square) \times (a \times \square) \times (a \times \square) \times (a \times \square) \times (a \times \square)$
 $= a^\square$

4 Find the value of each of the following.

- a 6^0 b 21^0 c 2^0 d 1^0
- e $(3.7)^0$ f 582^0 g $\left(\frac{3}{4}\right)^0$ h 2760^0

Hint:
 $a^0 = 1$



Fluency

5–7(½)

5–9(½)



Example 13 Using index law 3

Apply index law 3 to simplify each of the following.

a $(x^5)^4$

b $3(y^5)^2$

Solution

Explanation

a $(x^5)^4 = x^{5 \times 4}$
 $= x^{20}$

Keep x as the base and multiply the indices.

b $3(y^5)^2 = 3y^{5 \times 2}$
 $= 3y^{10}$

Keep y and multiply the indices. The power of 2 is only applied to what is inside the brackets.

The 3 is unchanged.

Now you try

Apply index law 3 to simplify each of the following.

a $(a^3)^7$

b $2(b^2)^4$

- 5 Apply index law 3 to simplify each of the following. Leave your answers in index form.

a $(y^6)^2$

b $(m^3)^6$

c $(x^2)^5$

d $(b^3)^4$

e $(3^2)^3$

f $(4^3)^5$

g $(3^5)^6$

h $(7^5)^2$

i $5(m^8)^2$

j $4(q^7)^4$

k $-3(c^2)^5$

l $2(j^4)^6$

Hint: Keep the base. Multiply the indices.



Example 14 Using the zero power

Apply the zero power rule to evaluate each of the following.

a $(-3)^0$

b $3(5x)^0$

c $2y^0 - (3y)^0$

Solution

Explanation

a $(-3)^0 = 1$

Any number raised to the power of 0 is 1.

b $3(5x)^0 = 3 \times 1$
 $= 3$

Everything in the brackets is to the power of 0 so $(5x)^0$ is 1. The 3 is not to the power of 0.

c $2y^0 - (3y)^0 = 2 \times 1 - 1$
 $= 2 - 1$
 $= 1$

 $2y^0$ has no brackets so the power applies to the y only, so $2y^0 = 2 \times y^0 = 2 \times 1$ while $(3y)^0 = 1$.

Now you try

Apply the zero power rule to evaluate each of the following.

a $\left(\frac{2}{3}\right)^0$

b $2(7y)^0$

c $(6y)^0 + 2y^0$

7C

6 Evaluate each of the following.

a 5^0

b 9^0

c $(-6)^0$

d $(-3)^0$

Hint: Any number (except zero) raised to the power 0 equals 1.



e $(4)^0$

f $\left(\frac{3}{4}\right)^0$

g $\left(-\frac{1}{7}\right)^0$

h $(4y)^0$

i $5m^0$

j $-3p^0$

k $6x^0 - 2x^0$

l $-5n^0 - (8n)^0$

m $(3x^4)^0$

n $1^0 + 2^0 + 3^0$

o $3a^0 + (3a)^0$

p $100^0 - a^0$



Example 15 Combining index laws 1 and 3

Simplify $(x^2)^3 \times (x^3)^5$ by applying the various index laws.

Solution

$$\begin{aligned}(x^2)^3 \times (x^3)^5 &= x^{2 \times 3} \times x^{3 \times 5} \\ &= x^6 \times x^{15} \\ &= x^{21}\end{aligned}$$

Explanation

Use index law 3 to remove brackets first by multiplying indices. Then use index law 1 to add indices.

Now you try

Simplify $(a^3)^3 \times (a^2)^4$ by applying the varying index laws.

7 Simplify each of the following by combining various index laws.

a $4 \times (4^3)^2$

b $(3^4)^2 \times 3$

c $x \times (x^0)^5$

d $y^5 \times (y^2)^4$

e $b^5 \times (b^3)^3$

f $(a^2)^3 \times a^4$

g $(d^3)^4 \times (d^2)^6$

h $(y^2)^6 \times (y)^4$

i $z^4 \times (z^3)^2 \times (z^5)^3$

Hint: First remove brackets by multiplying indices. Remember that $4 = 4^1$.



Example 16 Combining index laws 2 and 3

Simplify $\frac{(m^3)^4}{m^7}$ by applying index laws.

Solution

$$\begin{aligned}\frac{(m^3)^4}{m^7} &= \frac{m^{3 \times 4}}{m^7} \\ &= \frac{m^{12}}{m^7} \\ &= m^5\end{aligned}$$

Explanation

Remove brackets by multiplying indices then simplify using index law 2.

$$12 - 7 = 5$$

Now you try

Simplify $\frac{a^8}{(a^2)^3}$ by applying index laws.

8 Simplify each of the following.

a $\frac{(b^2)^5}{b^4}$

b $\frac{(x^4)^3}{x^7}$

c $\frac{(y^3)^3}{y^3}$

d $7^8 \div (7^3)^2$

e $(4^2)^3 \div 4^5$

f $(3^6)^3 \div (3^5)^2$

g $(m^3)^6 \div (m^2)^9$

h $(y^5)^3 \div (y^6)^2$

i $(h^{11})^2 \div (h^5)^4$

Hint: First remove brackets by multiplying the powers.





Example 17 Combining index laws 1, 2 and zero power

Simplify $\frac{4x^2 \times 3x^3}{6x^5}$ by applying index laws.

Solution

$$\begin{aligned}\frac{4x^2 \times 3x^3}{6x^5} &= \frac{4 \times 3 \times x^2 \times x^3}{6x^5} \\ &= \frac{12x^5}{6x^5} \\ &= 2x^0 \\ &= 2 \times 1 \\ &= 2\end{aligned}$$

Explanation

Regroup, then simplify the numerator first by multiplying numbers and adding indices of base x . $12 \div 6 = 2$, and subtract indices: $5 - 5 = 0$

The zero power says $x^0 = 1$.

Now you try

Simplify $\frac{5y^4 \times 3y^2}{10y^6}$ by applying index laws.

9 Simplify each of the following using various index laws.

a $\frac{3x^4 \times 6x^8}{9x^{12}}$

b $\frac{5x^5 \times 4x^6}{2x^{10}}$

c $\frac{24(x^4)^4}{8(x^4)^2}$

d $\frac{4(d^4)^3 \times (e^4)^2}{8(d^2)^5 \times e^7}$

e $\frac{6(m^3)^2(n^5)^3}{15(m^5)^0(n^2)^7}$

f $\frac{2(a^3)^4(b^2)^6}{16(a^0)(b^6)^2}$

Hint: Remove brackets, then rearrange with numbers first and then like bases grouped together.



Problem-solving and reasoning

10

10, 11

10 If m and n are positive integers, in how many ways can $(a^m)^n = a^{16}$? Show each possibility.

11 Explain the error made in the following problems, then give the correct answer.

a $(a^4)^5 = a^9$

b $3(x^4)^2 = 9x^6$

c $(2x)^0 = 2$



Rabbits!

—

12



12 There are 100 rabbits on Mt Burrow at the start of the year 2015. The rule for the number of rabbits, N , after t years (from the start of the year 2015) is $N = 100 \times 2^t$.

a Find the number of rabbits at:

i $t = 2$ ii $t = 6$ iii $t = 0$

b Find the number of rabbits at the beginning of:

i 2018 ii 2022 iii 2025

c How many years will it take for the population to first rise to more than 500 000? Give a whole number of years.



7D Index laws 4 and 5

Learning intentions

- To know the index laws for removing brackets over multiplication and division
- To be able to expand and simplify expressions using index laws 4 and 5
- To be able to combine a range of index laws to simplify more complex expressions

Key vocabulary: index law

It is common to find expressions such as $(2x)^3$ and $\left(\frac{x}{3}\right)^4$ in mathematical problems. These are different to most of the expressions in previous sections. They contain more than one single number or pronumeral, connected by multiplication or division, raised to a power. These expressions can also be simplified using two index laws that remove the brackets.

Consider $(a \times b)^6$.

$$\begin{aligned} \text{Using expanded form: } (a \times b)^6 &= \overbrace{ab \times ab \times ab \times ab \times ab \times ab}^{\text{6 factors of } ab} \\ &= \overbrace{a \times a \times a \times a \times a \times a}^{\text{6 factors of } a} \times \overbrace{b \times b \times b \times b \times b \times b}^{\text{6 factors of } b} \\ &= a^6 \times b^6 \end{aligned}$$

So this becomes a product of 6 factors of a and 6 factors of b .

$$\begin{aligned} \text{Also, } \left(\frac{a}{b}\right)^6 &= \overbrace{\frac{a}{b} \times \frac{a}{b} \times \frac{a}{b} \times \frac{a}{b} \times \frac{a}{b} \times \frac{a}{b}}^{\text{6 factors of } \frac{a}{b}} \\ &= \frac{\overbrace{a \times a \times a \times a \times a \times a}^{\text{6 factors of } a}}{\overbrace{b \times b \times b \times b \times b \times b}^{\text{6 factors of } b}} \\ &= \frac{a^6}{b^6} \end{aligned}$$

So to remove the brackets we can raise each of a and b to the power 6.

➔ Lesson starter: Discovering laws 4 and 5

Use the expanded form of $(2x)^3$ and $\left(\frac{x}{3}\right)^4$ to help simplify the expressions.

$$\begin{aligned} (2x)^3 &= 2x \times \square \times \square \\ &= 2 \times 2 \times 2 \times \square \times \square \times \square \\ &= 2^{\square} \times \square^{\square} \end{aligned}$$

$$\begin{aligned} \left(\frac{x}{3}\right)^4 &= \frac{x}{3} \times \square \times \square \times \square \\ &= \frac{x \times \square \times \square \times \square}{3 \times \square \times \square \times \square} \\ &= \frac{\square^{\square}}{\square^{\square}} \end{aligned}$$

- Repeat these steps to also simplify the expressions $(3y)^4$ and $\left(\frac{x}{2}\right)^5$.
- What do you notice about the given expressions and the answer in each case? Can you express this as a rule or law in words?

Key ideas

- Index law 4: $(a \times b)^m = (ab)^m = a^m b^m$
 - If the product of two or more numbers is raised to the power of m , raise each number in the brackets to the power of m . For example: $(2x)^2 = 2^2 x^2 = 4x^2$.
- Index law 5: $\left(\frac{a}{b}\right)^m = \frac{a^m}{b^m}$ and $b \neq 0$
 - If the quotient of two numbers is raised to the power of m , raise each number in the brackets to the power of m . For example: $\left(\frac{y}{3}\right)^3 = \frac{y^3}{3^3} = \frac{y^3}{27}$.

Exercise 7D

Understanding

1–4

4

1 Copy and complete index laws 4 and 5.

a $(a \times b)^m = a^m \times \square$

b $\left(\frac{a}{b}\right)^m = \frac{a^m}{\square}$

2 Copy and complete this working.

$$\begin{aligned} \text{a } (ab)^4 &= ab \times \square \times \square \times \square \\ &= a \times \square \times \square \times \square \times b \times \square \times \square \times \square \\ &= a^4 \times \square \end{aligned}$$

$$\begin{aligned} \text{b } \left(\frac{x}{6}\right)^3 &= \frac{x}{6} \times \square \times \square \\ &= \frac{x \times \square \times \square}{6 \times \square \times \square} \\ &= \frac{x^3}{\square} \end{aligned}$$

3 Copy and complete these bracket expansions.

a $(xy)^5 = x^\square y^\square$

b $(2m)^3 = 2^\square m^\square$

c $(abc)^4 = a^4 b^\square c^\square$

d $\left(\frac{5}{k}\right)^3 = \frac{5^3}{k^\square}$

e $\left(\frac{a}{m}\right)^5 = \frac{a^\square}{m^\square}$

f $\left(\frac{2}{3}\right)^4 = \frac{2^\square}{3^\square} = \frac{16}{\square}$

Hint: Raise each number or pronumeral in the brackets to the power.



4 Copy and complete these bracket expansions.

a $6(ab)^2 = 6a^\square b^\square$

b $4(xy)^3 = \square x^\square y^\square$

$$\begin{aligned} \text{c } 7(2m)^2 &= 7 \times 2^\square m^\square \\ &= 7 \times \square \times m^2 \\ &= \square m^2 \end{aligned}$$

$$\begin{aligned} \text{d } 4(3ab)^2 &= \square \times 3^\square a^\square b^\square \\ &= 4 \times \square a^\square b^\square \\ &= \square a^\square b^\square \end{aligned}$$

Hint: The index outside the brackets only applies to the values inside the brackets.



Fluency

5–7(½)

5–7(½)



Example 18 Using index law 4

Expand each of the following using the fourth index law.

a $(3a)^2$

b $(9a^3)^2$

Solution

Explanation

$$\begin{aligned} \text{a } (3a)^2 &= 3^2 \times a^2 \\ &= 9a^2 \end{aligned}$$

Apply the power of 2 to each factor in the brackets.

Continued on next page

7D

$$\begin{aligned} \text{b } (9a^3)^2 &= 9^2(a^3)^2 \\ &= 81a^{3 \times 2} \\ &= 81a^6 \end{aligned}$$

Raise 9 and (a^3) to the power of 2.
 $9^2 = 9 \times 9 = 81$, $(a^3)^2 = a^{3 \times 2} = a^6$

Now you try

Expand each of the following using the fourth index law.

$$\text{a } (4x)^3 \qquad \text{b } (2y^4)^4$$

5 Expand each of the following using the fourth index law. Evaluate numbers raised to a power.

$$\begin{array}{llll} \text{a } (2x)^3 & \text{b } (5y)^2 & \text{c } (4a)^3 & \text{d } (3r)^2 \\ \text{e } (3b)^4 & \text{f } (7r)^3 & \text{g } (2h^2)^4 & \text{h } (5c^2)^4 \\ \text{i } (3a^2)^3 & \text{j } (7p^4)^2 & \text{k } (5m^3)^2 & \text{l } (3y^{10})^2 \end{array}$$

Hint: The index outside the brackets must be applied to each number or pronumeral inside the brackets.

**Example 19 Using index law 5**

Apply the fifth index law to the following.

$$\text{a } \left(\frac{x}{2}\right)^3 \qquad \text{b } \left(\frac{m^3}{5}\right)^2$$

Solution**Explanation**

$$\begin{aligned} \text{a } \left(\frac{x}{2}\right)^3 &= \frac{x^3}{2^3} \\ &= \frac{x^3}{8} \end{aligned}$$

Raise each factor in the brackets to the power of 3.

$$\begin{aligned} \text{b } \left(\frac{m^3}{5}\right)^2 &= \frac{(m^3)^2}{5^2} \\ &= \frac{m^{3 \times 2}}{5^2} \\ &= \frac{m^6}{25} \end{aligned}$$

Raise m^3 and 5 to the power of 2.
 $(m^3)^2 = m^{3 \times 2} = m^6$

Now you try

Apply the fifth index law to the following.

$$\text{a } \left(\frac{a}{b}\right)^2 \qquad \text{b } \left(\frac{3a}{b^2}\right)^3$$

6 Apply the fifth index law to expand the following. Evaluate numbers raised to a power.

$$\begin{array}{llll} \text{a } \left(\frac{p}{q}\right)^3 & \text{b } \left(\frac{x}{y}\right)^4 & \text{c } \left(\frac{4}{y}\right)^3 & \text{d } \left(\frac{5}{p^2}\right)^4 \\ \text{e } \left(\frac{2}{r^3}\right)^2 & \text{f } \left(\frac{s^3}{7}\right)^2 & \text{g } \left(\frac{7}{x^3}\right)^2 & \text{h } \left(\frac{w^4}{10}\right)^2 \\ \text{i } \left(\frac{a^2}{5}\right)^3 & \text{j } \left(\frac{m^2}{2}\right)^4 & \text{k } \left(\frac{2m}{n}\right)^5 & \text{l } \left(\frac{2a^2}{3}\right)^3 \end{array}$$

Hint: Recall:
 $4^3 = 4 \times 4 \times 4 = 64$





Example 20 Using index law 4 for more complex expressions

Expand each of the following using the fourth index law.

a $(-2x^3y)^4$

b $4(c^2d^3)^5$

Solution

Explanation

$$\begin{aligned} \mathbf{a} \quad (-2x^3y)^4 &= (-2)^4(x^3)^4y^4 \\ &= 16x^{12}y^4 \end{aligned}$$

Raise each value in the brackets to the power of 4.
Evaluate $(-2)^4 = -2 \times (-2) \times (-2) \times (-2)$ and simplify $(x^3)^4$ using law 3.

$$\begin{aligned} \mathbf{b} \quad 4(c^2d^3)^5 &= 4(c^2)^5(d^3)^5 \\ &= 4c^{10}d^{15} \end{aligned}$$

Raise each value in the brackets to the power of 5.
Note that the coefficient (4) is not raised to the power of 5 since it is not in the brackets. Simplify using index laws.

Now you try

Expand each of the following using the fourth index law.

a $(-4a^2b)^2$

b $6(a^3b^2)^4$

7 Expand each of the following using the fourth index law.

a $(2x^3y^2)^5$

b $9(p^2q^4)^3$

c $2(x^3y)^2$

d $(8t^2u^9v^4)^0$

e $(-3w^3y)^3$

f $-4(p^4qr)^2$

g $(-5s^7t)^2$

h $-(-2x^4yz^3)^3$

i $-3(-2ab^2)^3$

Hint: Powers only apply to numbers or pronumerals inside the brackets.



Problem-solving and reasoning

8(½)

8–9(½)



Example 21 Using index law 5 for more complex expressions

Apply the fifth index law to $\left(\frac{-2a^2}{3bc^3}\right)^4$.

Solution

Explanation

$$\begin{aligned} \left(\frac{-2a^2}{3bc^3}\right)^4 &= \frac{(-2)^4a^8}{3^4b^4c^{12}} \\ &= \frac{16a^8}{81b^4c^{12}} \end{aligned}$$

Raise each value in the brackets to the power of 4.
Evaluate $(-2)^4$ and 3^4 .

Now you try

Apply the fifth index law to $\left(\frac{-3x^2}{2yz^3}\right)^3$.

7D

8 Apply the fifth index law to expand the following. Evaluate numbers that are raised to a power.

a $\left(\frac{3n^3}{2m^4}\right)^3$

b $\left(\frac{-2r}{n}\right)^4$

c $\left(\frac{-3f}{2^3g^5}\right)^2$

d $\left(\frac{5w^4y}{2x^3}\right)^2$

e $\left(\frac{-3x}{2y^3g^5}\right)^2$

f $\left(\frac{3km^3}{4n^7}\right)^3$

g $-\left(\frac{-5w^4y}{2zx^3}\right)^2$

h $\left(-\frac{3x^2y^3}{2a^5b^3}\right)^2$



Example 22 Using a variety of index laws

Simplify each of the following by applying various index laws.

a $a(-2a^2b)^3$

b $\left(\frac{x^2y^3}{c}\right)^3 \times \left(\frac{xc}{y}\right)^4$

Solution

$$\begin{aligned} \text{a } a(-2a^2b)^3 &= a(-2)^3(a^2)^3b^3 \\ &= a \times (-8a^6b^3) \\ &= -8a^7b^3 \end{aligned}$$

Explanation

Apply the power 3 to the values inside the brackets.

$$(-2)^3 = -2 \times (-2) \times (-2) = -8$$

$$(a^2)^3 = a^{2 \times 3} = a^6$$

Combine powers with a common base:

$$a \times a^6 = a^{1+6} = a^7$$

$$\begin{aligned} \text{b } \left(\frac{x^2y^3}{c}\right)^3 \times \left(\frac{xc}{y}\right)^4 &= \frac{x^6y^9}{c^3} \times \frac{x^4c^4}{y^4} \\ &= \frac{x^{10}y^9c^4}{c^3y^4} \\ &= cx^{10}y^5 \end{aligned}$$

Raise each value in the brackets to the power. Multiply the numerators using law 1 then divide using law 2.

Write the answer in alphabetical order.

Now you try

Simplify each of the following by applying various index laws.

a $2(-3ab^2)^2$

b $\left(\frac{xy^2}{b}\right)^2 \times \left(\frac{b^2}{xy^4}\right)$

9 Simplify each of the following by applying the various index laws.

a $a(3b)^2$

b $a(3b^2)^3$

c $-3(2a^3b^4)^2a^2$

d $2(3x^2y^3)^3$

e $(-4b^2c^5d)^3$

f $a(2a)^3$

g $a(3a^2)^2$

h $5a^3(-2a^4b)^3$

i $-5(-2m^3pt^2)^5$

j $\left(\frac{-3x^2y^0}{5a^5b^3}\right)^3$

k $\left(\frac{a^3b}{c}\right)^3 \times \left(\frac{ac^4}{b}\right)^2$

l $\left(\frac{x^2z}{y}\right)^4 \times \left(\frac{xy^2}{z}\right)^3$

Hint: Remove brackets. Combine numerator. Divide for parts j to l.





Germinating seeds

—

10

- 10** The rule for the number of seeds germinating in a glass house over a two-week period is given by $N = \left(\frac{t}{2}\right)^3$, where N is the number of germinating seeds and t is the number of days.
- a** Find the number of germinating seeds after:
- i** 4 days
 - ii** 10 days
- b** Use index law 5 to rewrite the rule without brackets.
- c** Use your rule in part **b** to find the number of seeds germinating after:
- i** 6 days
 - ii** 4 days
- d** Find the number of days required to germinate:
- i** 64 seeds
 - ii** 1 seed



7E Negative indices

Learning intentions

- To know how negative indices can be equivalently expressed using positive indices
- To be able to express negative indices in terms of positive indices
- To be able to use the index laws with negative indices

Key vocabulary: negative, index/indices, positive

We know that $2^3 = 8$ and $2^0 = 1$ but what about 2^{-1} or 2^{-6} ? Numbers written in index form using negative indices also have meaning in mathematics.

Consider the expression $= \frac{a^2}{a^5}$

Method 1: Using law 2

$$\frac{a^2}{a^5} = a^{2-5}$$

$$= a^{-3} \text{ (from index law 2)}$$

Method 2: By cancelling

$$\frac{a^2}{a^5} = \frac{\overset{1}{a} \times \overset{1}{a}}{a \times a \times a \times \underset{1}{a} \times \underset{1}{a}}$$

$$= \frac{1}{a^3}$$

So we can see that $a^{-3} = \frac{1}{a^3}$

Lesson starter: Continuing the pattern

Explore the use of negative indices by completing this table.

Index form	2^4	2^3	2^2	2^1	2^0	2^{-1}	2^{-2}	2^{-3}
Whole number or fraction	16	8					$\frac{1}{4} = \frac{1}{2^2}$	

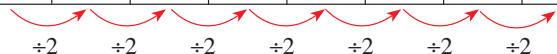

- What do you notice about the numbers with negative indices in the top row and the fractions in the second row?
- Can you describe this connection in words?
- What might be another way of writing 2^{-7} or 5^{-4} ?

Key ideas

- To express a negative index as a positive index use the following rules:

$$a^{-m} = \frac{1}{a^m} \text{ and } a^m = \frac{1}{a^{-m}}$$

a raised to the power $-m$ is equal to the reciprocal of a raised to the power m . ($a \neq 0$)

For example: $5^{-2} = \frac{1}{5^2}$, $\frac{1}{3^{-4}} = 3^4$.

- Recall: the reciprocal of $\frac{a}{b}$ is $\frac{b}{a}$.
- All the index laws also apply to expressions with negative indices.

Exercise 7E

Understanding

1-4

4

1 Write the following using positive indices. For example: $\frac{1}{8} = \frac{1}{2^3}$.

a $\frac{1}{4}$

b $\frac{1}{9}$

c $\frac{1}{125}$

d $\frac{1}{27}$

Hint: Write the denominator as a power of a prime number.



2 Copy and complete these tables.

a

Index form	3^4	3^3	3^2	3^1	3^0	3^{-1}	3^{-2}	3^{-3}
Whole number or fraction	81	27					$\frac{1}{9} = \frac{1}{3^2}$	

$\xrightarrow{+3}$ $\xrightarrow{+3}$ $\xrightarrow{+3}$ $\xrightarrow{+3}$ $\xrightarrow{+3}$ $\xrightarrow{+3}$ $\xrightarrow{+3}$

b

Index form	10^4	10^3	10^2	10^1	10^0	10^{-1}	10^{-2}	10^{-3}
Whole number or fraction	10 000							$\frac{1}{1000} = \frac{1}{10^3}$

$\xrightarrow{+10}$ $\xrightarrow{+10}$ $\xrightarrow{+10}$ $\xrightarrow{+10}$ $\xrightarrow{+10}$ $\xrightarrow{+10}$ $\xrightarrow{+10}$

3 Copy and complete each of the following.

a $10^{-4} = \frac{1}{10^\square}$

b $3^{-2} = \frac{1}{3^\square}$

c $7^{-3} = \frac{1}{7^\square}$

Hint:

$$a^{-m} = \frac{1}{a^m}$$

So $10^{-4} = \frac{1}{10^4}$



4 Copy and complete each of the following.

a $\frac{1}{3^{-4}} = 3^\square$

b $\frac{1}{7^{-6}} = 7^\square$

c $\frac{1}{8^{-3}} = 8^\square$

Hint:

$$\frac{1}{a^{-m}} = a^m$$

So $\frac{1}{3^{-4}} = 3^4$



Fluency

5-7(1/2)

5-8(1/2)



Example 23 Using $a^{-m} = \frac{1}{a^m}$

Rewrite the following using positive indices.

a 3^{-2}

b 5×4^{-3}

Solution

Explanation

a $3^{-2} = \frac{1}{3^2}$

Use $a^{-m} = \frac{1}{a^m}$.

$$\begin{aligned} \text{b } 5 \times 4^{-3} &= \frac{5}{1} \times \frac{1}{4^3} \\ &= \frac{5}{4^3} \end{aligned}$$

The 5 does not have a negative power so it remains unchanged.
 $4^{-3} = \frac{1}{4^3}$, $5 \times 1 = 5$, $1 \times 4^3 = 4^3$

Now you try

Rewrite the following using positive indices.

a 6^{-4}

b 7×2^{-4}

7E

- 5 Write each of the following with positive indices.
- a 5^{-2} b 7^{-4} c 8^{-3} d 3^{-5}
 e 9^{-2} f 10^{-3} g 4^{-5} h 2^{-3}
- 6 Rewrite the following with positive indices only.
- a 3×2^{-4} b 5×4^{-3} c 7×5^{-6}
 d 2×3^{-4} e 4×3^{-5} f 9×5^{-2}
 g 8×7^{-3} h 6×5^{-6} i 1×4^{-2}

Hint:

Remember: $a^{-m} = \frac{1}{a^m}$

So $5^{-2} = \frac{1}{5^2}$



Hint:

$$\textcircled{5} \times 2^{-3} = \frac{5}{2^3}$$

Don't change

Example 24 Using $\frac{1}{a^{-m}} = a^m$

Rewrite the following with positive indices.

a $\frac{1}{2^{-3}}$

b $\frac{7}{3^{-2}}$

Solution

Explanation

a $\frac{1}{2^{-3}} = 2^3$

Use $\frac{1}{a^{-m}} = a^m$.

b $\frac{7}{3^{-2}} = 7 \times \frac{1}{3^{-2}}$
 $= 7 \times 3^2$

The 7 remains unchanged.
 $\frac{1}{3^{-2}} = 3^2$

Now you try

Rewrite the following with positive indices.

a $\frac{1}{10^{-3}}$

b $\frac{5}{9^{-4}}$

- 7 Write each of the following with positive powers.

a $\frac{1}{2^{-4}}$

b $\frac{1}{3^{-2}}$

c $\frac{1}{4^{-3}}$

d $\frac{1}{6^{-5}}$

e $\frac{1}{5^{-3}}$

f $\frac{1}{8^{-5}}$

g $\frac{1}{7^{-3}}$

h $\frac{1}{9^{-4}}$

Hint:

Remember: $\frac{1}{a^{-m}} = a^m$

So $\frac{1}{2^{-4}} = 2^4$



- 8 Rewrite the following with positive indices only.

a $\frac{6}{4^{-3}}$

b $\frac{5}{8^{-2}}$

c $\frac{4}{7^{-5}}$

d $\frac{3}{2^{-5}}$

e $\frac{12}{5^{-4}}$

f $\frac{6}{10^{-3}}$

g $\frac{7}{9^{-4}}$

h $\frac{7}{10^{-6}}$

Hint:

Don't change

$$\textcircled{7} \frac{1}{3^{-4}} = 7 \times 3^4$$



Problem-solving and reasoning

9–10(½)

9–11(½), 12



Example 25 Changing to fractions

Rewrite 3×2^{-4} with a positive index and then as a fraction.**Solution**

$$\begin{aligned} 3 \times 2^{-4} &= 3 \times \frac{1}{2^4} \\ &= \frac{3}{2^4} \\ &= \frac{3}{16} \end{aligned}$$

Explanation

$$\begin{aligned} 2^{-4} &= \frac{1}{2^4} \\ 2^4 &= 2 \times 2 \times 2 \times 2 = 16 \end{aligned}$$

Now you tryRewrite 7×5^{-2} with a positive index and then as a fraction.

9 Rewrite each of these with positive indices and then as a fraction.

a 6×5^{-2}

b 2×3^{-2}

c 4×5^{-3}

d 6×7^{-1}

e 4×10^{-3}

f 2×10^{-1}

g 5×2^{-4}

h 4×5^{-1}

i 1×3^{-2}

Hint:

Remember: $5^1 = 5$

$$\begin{aligned} \text{So } 3 \times 5^{-1} &= 3 \times \frac{1}{5^1} \\ &= \frac{3}{5} \end{aligned}$$



Example 26 Changing to fractions and decimals

Rewrite 5×10^{-3} with a positive index and then as a fraction and a decimal.**Solution**

$$\begin{aligned} 5 \times 10^{-3} &= 5 \times \frac{1}{10^3} \\ &= \frac{5}{10^3} \\ &= \frac{5}{1000} \\ &= 0.005 \end{aligned}$$

Explanation

$$\begin{aligned} 10^{-3} &= \frac{1}{10^3} \\ 10^3 &= 10 \times 10 \times 10 = 1000 \\ 5 \text{ thousandths} &= 0.005 \end{aligned}$$

Now you tryRewrite 3×10^{-2} with a positive index and then as a fraction and a decimal.

10 Rewrite each of the following with positive indices and then as a fraction and a decimal.

a 2×10^{-3}

b 5×10^{-2}

c 7×10^{-1}

d 3×10^{-4}

e 5×10^{-4}

f 8×10^{-5}

g 2×10^{-6}

h 4×10^{-8}

Hint:

$\frac{1}{10} = 0.1, \frac{1}{100} = 0.01$

$\frac{1}{1000} = 0.001$

$\frac{1}{10000} = 0.0001$

$\frac{1}{100000} = 0.00001$



7E



Example 27 Evaluating without a calculator

Express using positive indices only, then evaluate without using a calculator.

a 3^{-4}

b $\frac{5}{3^{-2}}$

c $\left(\frac{2}{3}\right)^{-4}$

Solution

Explanation

$$\begin{aligned} \text{a } 3^{-4} &= \frac{1}{3^4} \\ &= \frac{1}{81} \end{aligned}$$

Express 3^{-4} as a positive power.
 $3^4 = 3 \times 3 \times 3 \times 3 = 81$

$$\begin{aligned} \text{b } \frac{5}{3^{-2}} &= 5 \times \frac{1}{3^{-2}} \\ &= 5 \times 3^2 \\ &= 5 \times 9 \\ &= 45 \end{aligned}$$

$$\begin{aligned} \frac{1}{3^{-2}} &= 3^2 \\ 3^2 &= 3 \times 3 = 9 \end{aligned}$$

$$\begin{aligned} \text{c } \left(\frac{2}{3}\right)^{-4} &= \frac{2^{-4}}{3^{-4}} \\ &= 2^{-4} \times \frac{1}{3^{-4}} \\ &= \frac{1}{2^4} \times 3^4 \\ &= \frac{3^4}{2^4} \\ &= \frac{81}{16} \end{aligned}$$

Apply the power to each numeral in the brackets using index law 5.

$$\frac{a}{b} = a \times \frac{1}{b}$$

$$2^{-4} = \frac{1}{2^4}, \frac{1}{3^{-4}} = 3^4$$

$$3^4 = 3 \times 3 \times 3 \times 3 = 81$$

$$2^4 = 2 \times 2 \times 2 \times 2 = 16$$

Give answer as an improper fraction.

Now you try

Express using positive indices only, then evaluate without using a calculator.

a 2^{-5}

b $\frac{2}{3^{-3}}$

c $\left(\frac{4}{5}\right)^{-2}$

11 Evaluate without the use of a calculator. Express in simplified form.

a 5^{-1}

b 3^{-2}

c 4×10^{-2}

d -5×10^{-3}

e $8 \times (2^2)^{-2}$

f $6^4 \times 6^{-6}$

g $8^{-7} \times (8^2)^3$

h $\frac{1}{8^{-1}}$

i $\frac{2}{2^{-3}}$

j $\frac{2^3}{2^{-3}}$

k $\left(\frac{3}{8}\right)^{-2}$

l $\left(\frac{4}{3}\right)^{-3}$

Hint: First write expressions using positive indices.



12 Describe the error made in these problems, then give the correct answer.

a $2x^{-2} = \frac{1}{2x^2}$

b $\frac{5}{a^4} = \frac{a^{-4}}{5}$

c $\frac{2}{(3b)^{-2}} = \frac{2b^2}{9}$



Kilograms and grams

—

13



13 a The mass of a small insect is 2^{-9} kg. How many grams is this? Round to two decimal places.

b The mass of an asteroid is 3^{20} kg. How many tonnes is this?

7A 1 Write the following in expanded form and evaluate parts **d–f**.

a b^4 **b** $2x^2y^3$ **c** $(3x)^3$ **d** 4^3 **e** $(-5)^4$ **f** $\left(\frac{3}{5}\right)^3$

7A 2 Write each of the following in index form.

a $5 \times 5 \times y \times y \times y \times y$
b $\frac{2}{3} \times \frac{2}{3} \times \frac{2}{3} \times \frac{5}{7} \times \frac{5}{7}$
c $4 \times a \times b \times 4 \times b \times b \times a \times b \times 4$

7A 3 Express the following as a product of their prime factors in index form.

a 45 **b** 120

7A 4 If $x = 3$, $y = 4$ and $z = -1$, evaluate these expressions.

a $(xz)^3$ **b** $\left(\frac{z}{y}\right)^2$ **c** $x(yz)^2$

7B 5 Simplify using the first two index laws; give your answer in index form.

a $4^3 \times 4^4$ **b** $9^6 \div 9^2$ **c** $x^5 \times x^3$
d $a^2b \times a^3b^4$ **e** $y^9 \div y^3$ **f** $18a^5 \div (6a^2)$
g $3mn^4 \times 4m^2n^3$ **h** $\frac{2x^5y^3}{4x^2y}$ **i** $\frac{-6a^3b^2}{3a^2b}$

7C 6 Apply index law 3 or the zero power rule to the following.

a $(x^4)^2$ **b** $5(y^3)^3$ **c** 4^0
d $(5m)^0$ **e** $(3x)^0 - 2x^0$ **f** $5(x^0)^3$

7B/7C 7 Combine index laws to simplify the following.

a $\frac{3m^2 \times 4m^3n^5}{m^4n^2}$ **b** $\frac{2(x^2)^3}{12x^4}$ **c** $\frac{(3a)^0 \times 4a^3b^2}{6ab^2}$

7D 8 Expand each of the following using the fourth and fifth index laws.

a $(2x)^2$ **b** $(2m^3)^4$ **c** $\left(\frac{x^2}{3}\right)^4$
d $4(-2ab^2)^3$ **e** $\left(\frac{3a^2}{5}\right)^3$ **f** $\left(\frac{-2a^2c}{7b^3}\right)^2$

7B/7C/7D 9 Combine index laws to simplify the following.

a $\frac{(4y^3)^2}{xy^2 \times 8(xy)^2}$ **b** $\left(\frac{3x^2}{4}\right)^3 \times \frac{2y^0}{x^4}$

7E 10 Rewrite the following with positive powers.

 **a** 5^{-2} **b** 3×4^{-4} **c** $\frac{1}{3^{-2}}$ **d** $\frac{5}{2^{-3}}$

7E 11 Evaluate the following without a calculator. Express part **d** as a decimal.

 **a** 9^{-2} **b** 5×2^{-2} **c** $\frac{6}{4^{-2}}$ **d** 6×10^{-4} **e** $\left(\frac{4}{5}\right)^{-3}$

7F Scientific notation

Learning intentions

- To know that scientific notation is a way of representing very large and very small numbers
- To know the form of numbers written in scientific notation
- To be able to express numbers using scientific notation and as a basic numeral

Key vocabulary: scientific notation, integer

It is common in practical situations to work with very large or very small numbers. For example, the number of cubic metres of concrete used to build the Hoover Dam in the United States was $3\,400\,000\text{ m}^3$. The mass of a molecule of water is $0.000000000000000000000000299$ grams. Numbers like this can be written more efficiently using powers of 10 with positive or negative indices. This is called scientific notation. The number is written using a number between 1 and 10 that is multiplied by a power of 10. This notation is also used to show very large and very small time intervals.



→ Lesson starter: Equal times

Work in pairs and help each other to complete this 'matching puzzle'.

For each time in the first column, find the equal time in the second column and in the third column.

Column 1	Column 2	Column 3
a 6 thousand seconds	6 000 000 s	6×10^2 s
b 6 millionths of a second	0.006 s	6×10^3 s
c 6 hundred seconds	0.06 s	6×10^6 s
d 6 million seconds	6000 s	6×10^{-2} s
e 6 thousandths of a second	0.000006 s	6×10^{-3} s
f 6 hundredths of a second	600 s	6×10^{-6} s

Key ideas

- Numbers written in **scientific notation** are expressed in the form $a \times 10^m$ where a is a number from 1 to less than 10 (or from greater than -10 to -1) and m is an integer.
 - To write numbers using scientific notation, place the decimal point after the first non-zero digit then multiply by a power of 10.
- Large numbers written in scientific notation will use positive powers of 10.
For example: 4 million years = 4 000 000 years

$$= 4 \times 1\,000\,000 \text{ years}$$

$$= 4 \times 10^6 \text{ years}$$

- Small numbers written in scientific notation will use negative powers of 10.
For example: 5 thousandths of a metre = 0.005 metres

$$= \frac{5}{1000} \text{ metres}$$

$$= \frac{5}{10^3} \text{ metres}$$

$$= 5 \times 10^{-3} \text{ metres}$$

Exercise 7F

Understanding

1–4

3, 4

- 1 Copy and complete this table. The first one has been done for you.

Scientific notation	Power of 10 expanded	Basic numeral
5×10^3	5×1000	5 000
3×10^4		
2×10^5		
7×10^2		
		70 000
		400 000

Hint: The power of 10 is equal to the number of zeros.



- 2 Copy and complete this table. The first one has been done for you.

Scientific notation	Positive power	Fraction	Basic numeral
2×10^{-4}	$\frac{2}{10^4}$	$\frac{2}{10\,000}$	0.0002
3×10^{-2}			
5×10^{-3}			
7×10^{-6}			
			0.009
			0.08

- 3 Which of the numbers 1000, 10 000 or 100 000 completes each equation?

- a** $6.2 \times \underline{\hspace{2cm}} = 62\,000$
b $9.41 \times \underline{\hspace{2cm}} = 9410$
c $1.03 \times \underline{\hspace{2cm}} = 103\,000$
d $3.2 \div \underline{\hspace{2cm}} = 0.0032$
e $5.16 \div \underline{\hspace{2cm}} = 0.0000516$
f $1.09 \div \underline{\hspace{2cm}} = 0.000109$

Hint: The number of zeros tells you how many places to move the decimal point.



- 4 If these numbers were written using scientific notation, would positive or negative indices be used?

- a** 2000
b 0.0004
c 19 300
d 0.00101431

Fluency

5–9(½)

5–9(½)

Example 28 Writing large numbers using scientific notation

Write 4 500 000 using scientific notation.

Solution

$$4\,500\,000 = 4.5 \times 10^6$$

Explanation

Place the decimal point after the first non-zero digit (4).

Multiply by 10^6 since decimal point has been moved six places to the left.**Now you try**

Write 71 000 using scientific notation.

5 Write the following using scientific notation.

a 40 000

b 2 300 000 000 000

c 16 000 000 000

d 7 200 000

e 3500

f 8 800 000

g 52 hundreds

h 3 million

i 21 thousands

Hint: Large numbers:
use 10 to a positive power.

Example 29 Writing small numbers using scientific notation

Write 0.0000004 using scientific notation.

Solution

$$0.0000004 = 4 \times 10^{-7}$$

ExplanationThe first non-zero digit is 4. Multiply by 10^{-7} since decimal point has been moved seven places to the right.**Now you try**

Write 0.0000275 using scientific notation.

6 Write the following using scientific notation.

a 0.000003

b 0.0004

c 0.00876

d 0.00000000073

e 0.00003

f 0.000000000125

g 0.00000000809

h 0.000000024

i 0.0000345

Hint: Small numbers:
use 10 to a negative power.

7 Write each of the following numbers using scientific notation.

a 6000

b 720 000

c 324.5

d 7869.03

e 8459.12

f 0.2

g 0.000328

h 0.00987

i 0.00001

j 460 100 000

k 17 467

l 128

Hint: Place the decimal
point after the first
non-zero digit.



Example 30 Writing basic numerals using positive powers

Express 9.34×10^6 as a basic numeral.

Solution

$$9.34 \times 10^6 = 9\,340\,000$$

Explanation

Move the decimal point six places to the right, so that the 9 increases in place value by six places from the units position to the millions position.

Now you try

Express 2.4×10^4 as a basic numeral.

- 8 Express each of the following as a basic numeral.
- | | | |
|-----------------------------|-----------------------------|--------------------------------|
| a 5.7×10^4 | b 3.6×10^6 | c 4.3×10^8 |
| d 3.21×10^7 | e 4.23×10^5 | f 9.04×10^{10} |
| g 1.97×10^8 | h 7.09×10^2 | i 6.357×10^5 |

Hint: Move the decimal point right to increase the place value of each digit.



Example 31 Writing basic numerals using negative powers

Express 4.71×10^{-6} as a basic numeral.

Solution

$$4.71 \times 10^{-6} = 0.00000471$$

Explanation

Move the decimal point six places to the left and insert zeros where necessary. The 4 decreases in place value by six places from the units position to the millionths position.

Now you try

Express 9.4×10^{-3} as a basic numeral.

- 9 Express each of the following as a basic numeral.
- | | | |
|--------------------------------|---------------------------------|--------------------------------|
| a 1.2×10^{-4} | b 4.6×10^{-6} | c 8×10^{-10} |
| d 3.52×10^{-5} | e 3.678×10^{-1} | f 1.23×10^{-7} |
| g 9×10^{-5} | h 5×10^{-2} | i 4×10^{-1} |

Hint: Move the decimal point left to decrease the place value of each digit.



Problem-solving and reasoning

10–11(½)

10–11(½), 12

- 10 Express each of the following approximate numbers using scientific notation.
- The mass of Earth is 6 000 000 000 000 000 000 000 kg.
 - The diameter of Earth is 40 000 000 m.
 - The diameter of a gold atom is 0.0000000001 m.
 - The radius of Earth's orbit around the Sun is 150 000 000 km.
 - The universal constant of gravitation is $0.0000000000667 \text{ Nm}^2/\text{kg}^2$.
 - The half-life of polonium-214 is 0.00015 seconds.
 - Uranium-238 has a half-life of 4 500 000 000 years.



7F

- 11 Express each of the following numbers as a basic numeral.
- Neptune is approximately 4.6×10^9 km from Earth.
 - A population of bacteria contained 8×10^{12} organisms.
 - Earth is approximately 3.84×10^5 km from the Moon.
 - A 50c coin is approximately 3.8×10^{-3} m thick.
 - The diameter of the nucleus of an atom is approximately 1×10^{-14} m.
 - The population of a city is 7.2×10^5 .

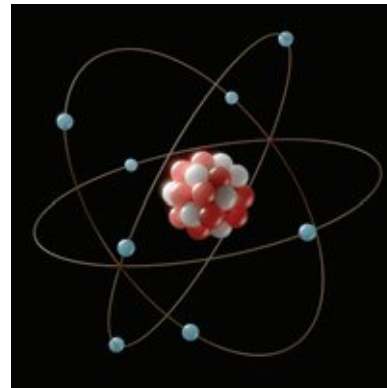

- 12 Write the answers to each of these problems using scientific notation.



- Two planets are 2.8×10^8 km and 1.9×10^9 km from their closest sun. What is the difference between these two distances?
- Two particles weigh 2.43×10^{-2} g and 3.04×10^{-3} g. Find the difference in their weights.



Scientific notation with numbers larger than 10

—

13

- 13 The number 47×10^4 is not written using scientific notation, since 47 is not a number between 1 and 10. The following shows how to convert to scientific notation.

$$\begin{aligned} 47 \times 10^4 &= 4.7 \times 10 \times 10^4 \\ &= 4.7 \times 10^5 \end{aligned}$$

Write these numbers using scientific notation.

- | | | | |
|------------------------------|-------------------------------|--------------------------------|----------------------------------|
| a 32×10^3 | b 41×10^5 | c 0.13×10^5 | d 0.092×10^3 |
| e 61×10^{-3} | f 424×10^{-2} | g 0.02×10^{-3} | h 0.0004×10^{-2} |



7G Scientific notation using significant figures

Learning intentions

- To know how significant figures are counted
- To be able to round to a given number of significant figures
- To be able to write a number using scientific notation correct to a given number of significant figures

Key vocabulary: scientific notation, significant figures

The number of digits used to record measurements depends on how accurately the measurements can be recorded. The volume of Earth, for example, has been calculated as $1\,083\,210\,000\,000\text{ km}^3$ using six significant figures and could be written using scientific notation as 1.08321×10^{12} . A more accurate calculation may include more non-zero digits in the last seven places.

The mass of a single oxygen molecule is known to be $0.000000000000000000000000053\text{ g}$. This shows two significant figures and is written using scientific notation as 5.3×10^{-26} .

On many calculators you will notice that very large or very small numbers are automatically converted to scientific notation using a certain number of significant figures. Numbers can also be entered into a calculator using scientific notation.



→ Lesson starter: Significant discussions

Work in pairs and sort these numbers into groups according to how many significant figures are in each number.

23	502	0.0018
7208	46	0.0001073
0.000907	1609	91
6182	6	0.0000741

Key ideas

- **Significant figures** are the important digits of a number which indicate how accurate it is.
- Significant figures are counted from left to right starting at the first non-zero digit. For example:
 - 38 041 shows five significant figures
 - 6.034 shows four significant figures
 - 0.0016 shows two significant figures
 - 0.00160 shows three significant figures.
- Zeros at the end of a number are counted for decimals (e.g. 0.00160) but not necessarily for whole numbers (e.g. 38 041 000).
- When using scientific notation, the first significant figure sits to the left of the decimal point. For example:
 - 3.217×10^4 shows four significant figures.
- Calculators can be used to work with scientific notation.
 - \boxed{E} or \boxed{EE} or \boxed{EXP} or $\boxed{\times 10^x}$ are common key names on calculators.
 - Pressing $2.37 \boxed{EE} 5$ gives 2.37×10^5 .
 - $2.37E5$ means 2.37×10^5 .

Exercise 7G

Understanding

1–4

3, 4

- 1 a Round each of these numbers to the nearest hundred.
 i 267 ii 32 740 iii 18 350
- b Round each of these numbers to the nearest tenth.
 i 0.063 ii 0.1902 iii 21.04
- c Round each of these numbers to the nearest thousand.
 i 267 540 ii 38 290 iii 4 060 990
- 2 Which of these numbers have two significant figures?
 62 100, 30 500, 42, 0.0071, 0.0805, 201 000

Hint:

Rounding rules:

Locate the first digit to the right of the required digit.

- Round down (leave it as it is) for a 4 or less
- Round up (increase by 1) for a 5 or more



- 3 Complete the tables, rounding each number to the given number of significant figures.

a 57 263

Significant figures	Rounded number
4	
3	57 300
2	
1	

b 0.0036612

Significant figures	Rounded number
4	
3	
2	
1	0.004

Hint: In 57 263, 6 is the fourth significant figure so round to the nearest 10 for four significant figures.



- 4 Are the following numbers written using scientific notation with three significant figures? (Yes or no)

a 4.21×10^4

b 32×10^{-3}

c 1800×10^6

d 0.04×10^2

e 1.89×10^{-10}

f 9.04×10^{-6}

Hint: The number to the left of the decimal point must be from 1 to less than 10.



Fluency

5–8(½)

5–9(½)

Example 32 Stating the number of significant figures

State the number of significant figures given in these numbers.

a 401

b 0.005012

c 3.2×10^7

Solution

Explanation

a Three significant figures

All three digits are significant.

b Four significant figures

Start counting at the first non-zero digit (5).

c Two significant figures

With scientific notation the first significant figure is to the left of the decimal point.

Now you try

State the number of significant figures given in these numbers.

a 7105

b 0.00016

c 4.21×10^{-2}

5 State the number of significant figures given in these numbers.

- a** 272 **b** 1007 **c** 30 101
d 19 **e** 0.0183 **f** 0.20
g 0.706 **h** 0.00109 **i** 4.21×10^3
j 2.905×10^{-2} **k** 1.07×10^{-6} **l** 5.90×10^5

Hint: Start counting from the first non-zero digit.



Example 33 Writing numbers using scientific notation and significant figures

Write these numbers using scientific notation and three significant figures.

- a** 2 183 000 **b** 0.0019482

Solution

Explanation

- a** $2\ 183\ 000 = 2.18 \times 10^6$ Put the decimal point after the first non-zero digit. The decimal point has moved six places so multiply by 10^6 . Round the third significant figure down (i.e. leave it as is) since the following digit (3) is less than 5.
- b** $0.0019482 = 1.95 \times 10^{-3}$ Move the decimal point three places to the right and multiply by 10^{-3} . Round the third significant figure up to 5 since the following digit (8) is greater than 4.

Now you try

Write these numbers using scientific notation and three significant figures.

- a** 472 000 **b** 0.00032

6 Write these numbers using scientific notation and three significant figures.

- a** 242 300 **b** 171 325 **c** 2829 **d** 3 247 000
e 0.00034276 **f** 0.006859 **g** 0.01463 **h** 0.001031
i 23.41 **j** 326.042 **k** 19.618 **l** 0.172046

7 Write each number using scientific notation, rounding to the number of significant figures given in the brackets.

- a** 47 760 (3) **b** 21 610 (2) **c** 4 833 160 (4)
d 37.16 (2) **e** 99.502 (3) **f** 0.014427 (4)
g 0.00201 (1) **h** 0.08516 (1) **i** 0.0001010 (1)

Hint: First round the number to the required number of significant figures.



Example 34 Using a calculator with scientific notation

Use a calculator to evaluate $3.67 \times 10^5 \times 23.6 \times 10^4$. Answer using scientific notation correct to four significant figures.

Solution

Explanation

- $3.67 \times 10^5 \times 23.6 \times 10^4$
 $= 8.661 \times 10^{10}$
- Use a calculator with an appropriate key sequence.
Write using scientific notation with four significant figures.
Look for a $\times 10^x$ or EXP button or similar.

Now you try

Use a calculator to evaluate $62.14 \times 10^2 \times 1.6 \times 10^4$. Answer using scientific notation correct to four significant figures.

7G



8 Use a calculator to evaluate each of the following. Write your answers using scientific notation correct to four significant figures.

a 4^{-6}

b 78^{-3}

c $(-7.3 \times 10^{-4})^{-5}$

d $\frac{3.185}{7 \times 10^4}$

e $2.13 \times 10^4 \times 9 \times 10^7$

f $5.671 \times 10^2 \times 3.518 \times 10^5$

g $9.419 \times 10^5 \times 4.08 \times 10^{-4}$

h $2.85 \times 10^{-9} \times 6.33 \times 10^{-3}$

i $12\,345^2$

j 87.14^8

k $\frac{1.83 \times 10^{26}}{4.5 \times 10^{22}}$

l $\frac{-4.7 \times 10^{-2} \times 6.18 \times 10^7}{3.2 \times 10^6}$



Example 35 Using a calculator with scientific notation and negative indices

Use a calculator to evaluate $7.6 \times 10^{-3} + \sqrt{2.4 \times 10^{-2}}$. Write your answer using scientific notation correct to four significant figures.

Solution

$$\begin{aligned} &7.6 \times 10^{-3} + \sqrt{2.4 \times 10^{-2}} \\ &= 0.1625 \text{ (to 4 sig. figs)} \\ &= 1.625 \times 10^{-1} \end{aligned}$$

Explanation

Use a calculator with an appropriate key sequence.

Write using scientific notation with a number between 1 and 10.

Now you try

Use a calculator to evaluate $\frac{\sqrt{5.1 \times 10^{-7}}}{4.32 \times 10^{-2}}$. Write your answer using scientific notation correct to four significant figures.



9 Use a calculator to evaluate each of the following. Write answers using scientific notation correct to five significant figures.

a $\sqrt{8756}$

b $\sqrt{634 \times 7.56 \times 10^7}$

c $8.6 \times 10^5 + \sqrt{2.8 \times 10^{-2}}$

d $-8.9 \times 10^{-4} + \sqrt{7.6 \times 10^{-3}}$

e $\frac{5.12 \times 10^{21} - 5.23 \times 10^{20}}{2 \times 10^6}$

f $\frac{8.942 \times 10^{47} - 6.713 \times 10^{44}}{2.5 \times 10^{19}}$

g $\frac{2 \times 10^7 + 3 \times 10^8}{5}$

h $\frac{4 \times 10^8 + 7 \times 10^9}{6}$

i $\frac{6.8 \times 10^{-8} + 7.5 \times 10^{27}}{4.1 \times 10^{27}}$

j $\frac{2.84 \times 10^{-6} - 2.71 \times 10^{-9}}{5.14 \times 10^{-6} + 7 \times 10^{-8}}$

Hint: For fraction calculations, insert brackets so that the numerator and denominator are calculated before division.



Problem-solving and reasoning

10, 11

10, 12, 13

- 10** The mass of Earth is approximately 6 000 000 000 000 000 000 kg. The mass of the Sun is 330 000 times the mass of Earth. Find the mass of the Sun. Express your answer using scientific notation correct to three significant figures.
- 11** The diameter of Earth is approximately 12 756 000 m. If the Sun's diameter is 109 times that of Earth, compute its diameter in kilometres. Express your answer using scientific notation correct to three significant figures.
- 12** Write these numbers from largest to smallest.
 2.41×10^6 , 24.2×10^5 , 0.239×10^7 , 2421×10^3 , 0.02×10^8
- 13** The following output is common on a number of different calculators and computers. Write down the number that you think they represent.
- | | | |
|--------------------|--------------------------|----------------------------|
| a 4.26E6 | b 9.1E-3 | c 5.04EE11 |
| d 1.931EE-1 | e $2.1 \wedge 06$ | f $6.14 \wedge -11$ |

Hint: First write each number using scientific notation.



Combining bacteria

—

14

- 14** A flask of type A bacteria contains 5.4×10^{12} cells and a flask of type B bacteria contains 4.6×10^8 cells. The two types of bacteria are combined in the same flask.
- a** How many bacterial cells are there now in the flask?
- b** If type A bacterial cells double every 8 hours, and type B bacterial cells triple every 8 hours, how many cells are in the flask after:
- i** 8 hours? **ii** one day?

Hint: Set up a table to show the number of each type of bacteria after every 8 hours.



Express your answers to part **b** using scientific notation correct to three significant figures.

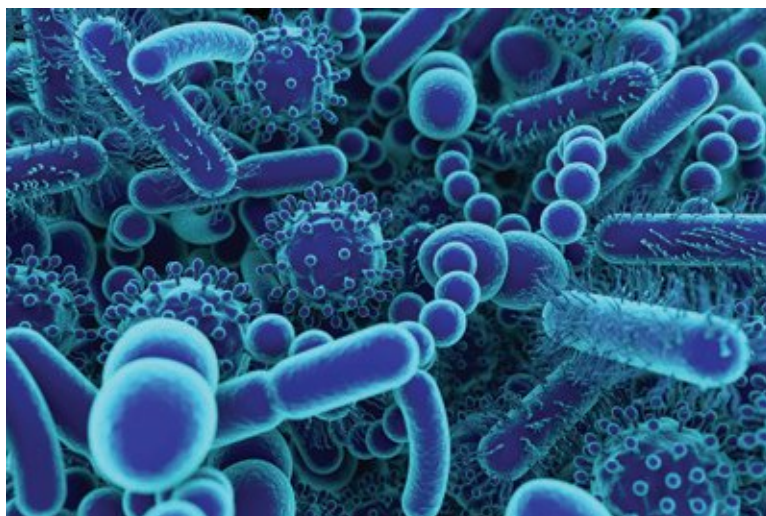



Maths@Work: Lab technician

Lab technicians work in laboratories supporting scientists by helping to carry out tests for research and to report their findings. Research can be done in medical, clinical and forensic labs as well as pharmaceutical and brand development labs.

Lab technicians require competent practical and technical skills as well as good communication skills, both verbal and written. An enquiring and analytical mind also helps. All these qualities are important in modern labs.

Mathematical skills are vital in this role. Determining growth rates of cultures can form part of a lab technician's work. Working in and with scientific notation is also required.



- Various types of cells each have different volumes and are measured in cubic micrometres (μm^3). Write the following volumes in μm^3 using scientific notation.
 - Red blood cell $100 \mu\text{m}^3$
 - Ear hair cell $4000 \mu\text{m}^3$
 - Lymphocyte $130 \mu\text{m}^3$
 - Beta cell $1000 \mu\text{m}^3$
 - Fat cell $600\,000 \mu\text{m}^3$
- The diameter of a human egg is $120 \mu\text{m}$. Recall that $1 \mu\text{m} = 1 \times 10^{-6} \text{ m}$.
 - Write this diameter in metres as a basic numeral.
 - Write this diameter in metres using scientific notation.
- The mass of one red blood cell is 1 picogram or 1×10^{-12} grams. Calculate the mass of these blood cell counts using grams and write the result using scientific notation.

a 2000 red blood cells	b 1 000 000 red blood cells
c 3×10^{12} red blood cells	
- A human being is said to be made up of $(3.7 \pm 0.8) \times 10^{13}$ cells.
 - What is the upper limit given here as a basic numeral?
 - What is the lower limit as a basic numeral?
- A half-life is the time taken for a quantity to halve in size. Write each of the following half-lives using scientific notation.
 - Carbon-14 has a half-life of 5700 years. (It is used by archaeologists to date historic objects.)
 - Uranium-238 has a half-life of 4 500 000 000 years.
 - Iodine-129 has a half-life of 15.7 million years.
 - Polonium-214 has a half-life of 150 microseconds (state the answer in seconds).

Hint:
1 microsecond = 1 millionth of a second.



- 6 Convert the half-lives in Question 5a, b and c into days using 365.25 days per year. State answers using scientific notation to three significant figures.
- 7 Yeast doubles every 90–120 minutes. Taking the median value, how long would it take for a food technician to grow 1 g of yeast to $\frac{1}{2}$ kg of yeast?
- 8 *E. coli* bacteria can double every 20–30 minutes. Using the median time, how many grams of *E. coli* has grown from 1 mg using the following times? Write each answer in scientific notation to three significant figures.
 - i 50 minutes
 - ii $8\frac{1}{3}$ hours
- 9 After each 'half-life' period, 1 g of radioactive isotope halves in quantity. List the 10 fractions of radioactive isotope remaining (in grams) after each of 10 half-lives. First list these fractions with positive powers of 2 and then with negative powers of 2.

Using technology

- 10 Radioactive isotopes have various medical applications.
 - a Set up the following spreadsheet to calculate quantities remaining after multiples of half-lives for the radioactive isotopes listed. Enter formulas in the shaded cells and format cells as 'number' to four decimal places.

	A	B	C	D	E	F	G
1	Calculation of time for multiple half-lives						
2				Quantity remaining in mg			
3	Application	Radioactive isotope	Initial quantity in mg	After 1 half-life	After 2 half-lives	After 4 half-lives	After 10 half-lives
4	Biochemical tracer	hydrogen-3	8				
5	Biomedical imaging	carbon-11	64.128				
6	Heart system tracer	sodium-24	24.73				
7	Red blood cell lifetime tracer	iron-59	7.86				
8	Radiation therapy for cancer	radium-226	4.25				

- b To help determine the correct dose, medical scientists need to calculate the length of time that a radioactive isotope lasts. Set up the following spreadsheet to calculate the total times for multiple half-lives. Enter formulas in the shaded cells and format cells as number to four decimal places.

	A	B	C	D	E	F	G	H
1	Calculation of time for multiple half-lives							
2			Half-life		Total time			
3	Application	Radioactive isotope	Value	Time unit	For 2 half-lives	For 4 half-lives	For 6 half-lives	For 10 half-lives
4	Biochemical tracer	hydrogen-3	12.32	hours				
5	Biomedical imaging	carbon-11	20.3	minutes				
6	Heart system tracer	sodium-24	14.951	hours				
7	Red blood cell lifetime tracer	iron-59	44.495	days				
8	Radiation therapy for cancer	radium-226	1600	years				

Rabbits and hares

The population of rabbits and hares in a particular part of the countryside are booming because fox numbers are low.

Present a report for the following tasks and ensure that you show clear mathematical workings, explanations and diagrams where appropriate.

Preliminary task

- a** A population of a certain colony of hares is modelled by the rule $P = 3^t$ where P is the population and t is in months. Find:
- the population after 6 months
 - the number of whole months for the population to reach at least 1000.
- b** A population of a certain colony of rabbits is modelled by the rule $P = 200 \times 2^t$ where P is the population and t is in months. Find:
- the population after 6 months
 - the number of whole months for the population to reach at least 20 000.

Modelling task

The problem is to determine the number of months required for the hare population to overtake the population of rabbits in a particular colony with the given data.

Time in months	0	1	2	3			
Month	Dec	Jan	Feb	Mar	Apr	May	June
Rabbit population	500	1000	2000	4000			
Hare population	1	4	16	64			

- Write down all the relevant information that will help solve this problem.
- Copy and extend the given table showing the population of rabbits and hares in the first 6 months.
- By what factor does the rabbit population increase each month?
- The rule for the population of rabbits is of the form $P = 500 \times ?^t$. State the missing number and re-write the rule for rabbits.
- By what factor does the hare population increase each month?
- The rule for the population of hares is of the form $P = ?^t$. State the missing number and rewrite the rule for hares.

- Use the rules outlined in parts **d** and **f** to confirm the population of:
 - rabbits initially (at $t = 0$)
 - rabbits after 6 months
 - hares after 6 months.
- Use the rules outlined in parts **d** and **f** to estimate the population of:
 - rabbits after 12 months
 - hares after 12 months
- Extend your table and use your rules to calculate the population numbers for the months from August to December.

Time in months	7					
Month	July	Aug	Sep	Oct	Nov	Dec
Rabbit population						
Hare population						

Formulate

Solve

- j** State the first month in which the hare population overtakes the population of rabbits.
- k** In which month is the hare population more than twice the rabbit population?
- l** In which month does the rabbit population exceed 1 million?

Evaluate
and
verify

- m** Summarise your results and describe any key findings.

Communicate

Extension question

A new population of 100 rabbits breed in a different part of the country. The population is modelled by the rule $P = 100 \times 4^t$ where t is in years from the beginning of 2021.

- a** What would you expect the population of rabbits be at the beginning of 2025?
- b** During what year will this rabbit population exceed:
 - i** 1 million
 - ii** 25 million?



- 1 A population of bacteria doubles every 5 minutes. What is this type of growth called? Solve this puzzle to find the answer.

Write the basic numeral for each of the following. Write the letter corresponding with each answer in the boxes below to form a word.

T $\frac{1}{10^3}$

L 2.15×10^3

I $\frac{9^5}{9^3}$

A 5×10^{-2}

O 2^{-2}

N 2^4

P $3^2 \times 2^2 - 3^0$

X $5^2 + 2^4 - 3^2 \times 4$

E $\frac{4^3}{8}$

<input type="text"/>	<input type="text"/>	<input type="text"/>	<input type="text"/>	<input type="text"/>	<input type="text"/>	<input type="text"/>	<input type="text"/>	<input type="text"/>	<input type="text"/>	<input type="text"/>
8	5	35	0.25	16	8	16	0.001	81	0.05	2150

- 2 Find the answer to these calculations without using a calculator:

a $2 \times 2 \times 2 \times 2 \times 2 \times 2 \times 2 \times 2 \times 2 \times 5 \times 5 \times 5 \times 5 \times 5 \times 5 \times 5 \times 5$

b $5 \times 5 \times 5 \times 5 \times 5 \times 4 \times 4 \times 4 \times 4 \times 4 \times 4 \times 5 \times 5 \times 5 \times 5 \times 5$

- 3 Show that this expression is equal to 1.

$$\frac{1}{2} \times \frac{a^2b}{3am} \times \frac{6a^3}{b^2} \times \frac{10(ab)^2}{2bm^3} \times \frac{m^4}{5a^6}$$

- 4 Insert brackets in this expression to make the given answer correct.

$$4a \times 3m^3 \times \left(\frac{a}{6m}\right)^2 = 3a^3m$$

- 5 Nick and Maddy have a big bag of 10-cent coins. They decide to make 30 piles of coins, starting with one coin in the first pile, then 2 coins in the second pile, 4 coins in the third pile, 8 in the fourth pile and so on, continuing to double the number of coins for each new pile. Given that each 10-cent coin is 2 mm thick, find the heights of the 1st, 5th, 10th, 15th, 20th, 25th and 30th piles and the value in dollars of each of these piles.
- 6 Each day that a bushfire burns in a National Park, the total area burnt is twice as big an area as the day before. If a National Park was totally burnt out in 15 days, on which day was the park only half burnt out?
- 7 It is thought that the game of chess was invented by an ancient Indian mathematician. The King was so pleased with the game that he offered the inventor any reward of his choice: rare jewels, bags of gold or even a large property.

To the King's surprise the Indian mathematician asked for some wheat! He asked for 1 grain for the first square of the chess board, 2 grains for the second square, 4 grains for the third square, 8 grains for the fourth square etc. continuing this way right up to the 64th square.

- a** If one grain of wheat weighs 2×10^{-8} tonnes, what weight of wheat would the inventor have received for the 64th square? Answer using scientific notation with three significant figures.
- b** How much money would this wheat be worth at the Australian price of \$275/tonne?

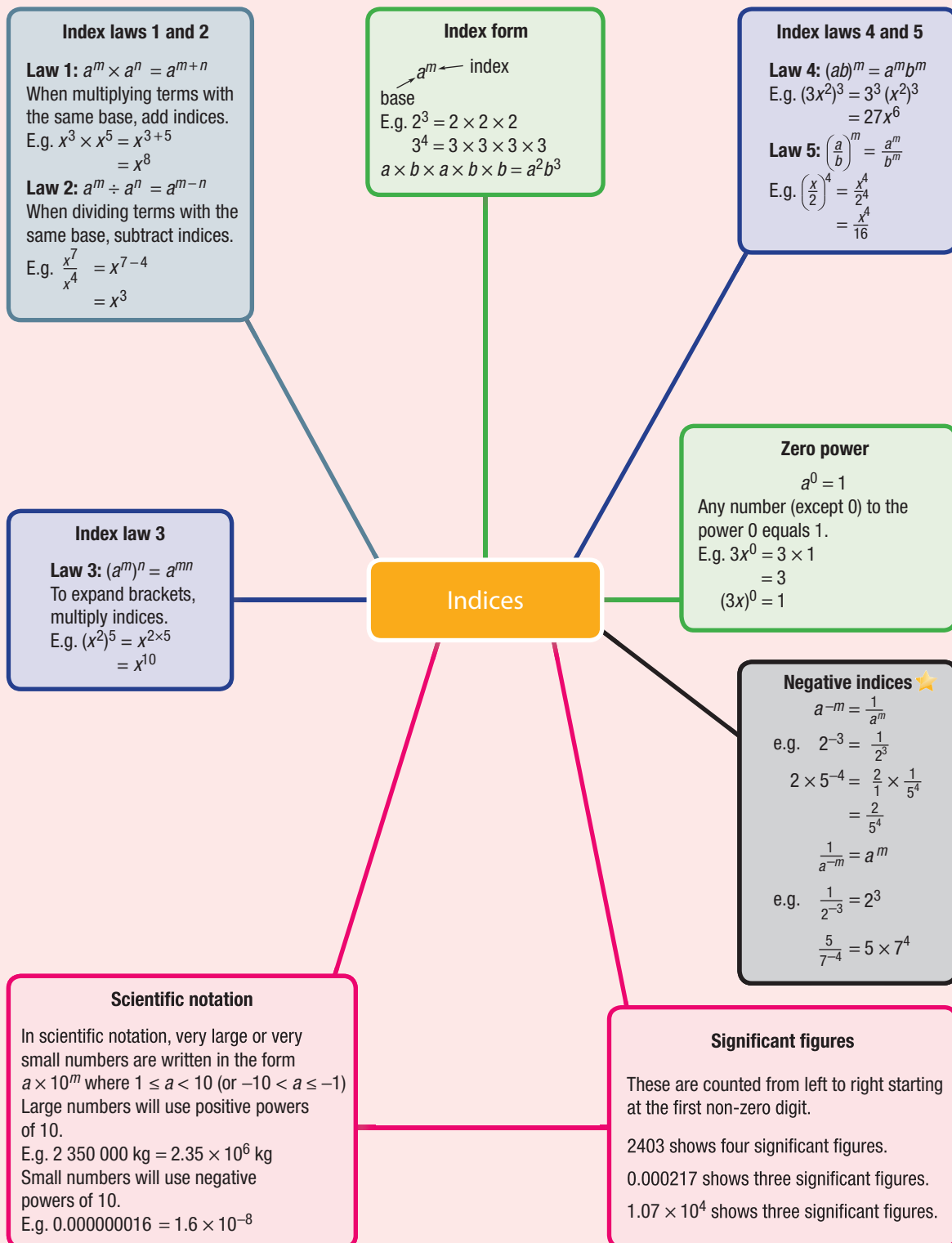

Chapter checklist

A version of this checklist that you can print out and complete can be downloaded from your Interactive Textbook.

		✓
7A	<p>1 I can write expressions in expanded form and simplify. e.g. Write the following in expanded form and simplify.</p> <p>a $(2ab)^3$ b $\left(\frac{2}{7}\right)^2$</p>	
7A	<p>2 I can write numbers and expressions using index form. e.g. Write the following in index form:</p> <p>a $\frac{7}{9} \times \frac{7}{9} \times \frac{7}{9} \times \frac{7}{9}$ b $2 \times a \times a \times b \times a \times b$</p>	
7A	<p>3 I can express a number as a product of its prime factors. e.g. Express 92 as a product of its prime factors.</p>	
7A	<p>4 I can evaluate expressions involving indices using substitution. e.g. If $a = 2$, $b = -3$ and $c = 11$, evaluate the following.</p> <p>a $(ab)^3$ b $\left(\frac{b}{c}\right)^2$</p>	
7B	<p>5 I can simplify expressions with numerical bases using index laws 1 and 2. e.g. Simplify, giving your answer in index form.</p> <p>a $4^3 \times 4^4$ b $7^5 \div 7$</p>	
7B	<p>6 I can use index law 1. e.g. Simplify the following using the first index law:</p> <p>a $a^3 \times a^7$ b $9x^2 \times 3x^3$</p>	
7B	<p>7 I can use index law 2. e.g. Simplify $y^6 \div y^2$ using the second index law.</p>	
7B	<p>8 I can combine index laws 1 and 2. e.g. Simplify: $\frac{3a^2b \times 4ab^3}{8a^2b^3}$.</p>	
7C	<p>9 I can simplify expressions containing the zero power. e.g. Evaluate using the zero power: $3^0 + 3a^0$</p>	
7C	<p>10 I can use index law 3. e.g. Simplify using the third index law: $5(x^3)^6$</p>	
7C	<p>11 I can combine index laws 1 to 3 and the zero power. e.g. Simplify the following</p> <p>a $(x^2)^3 \times (x^4)^2 \div x^{14}$ b $\frac{7a^3 \times 2a^4}{4a^5}$</p>	
7D	<p>12 I can use index laws 4 and 5 to simplify expressions. e.g. Simplify, using index laws.</p> <p>a $(2a^4)^3$ b $\left(\frac{-2b^2}{a^3}\right)^4$</p>	





7D	<p>13 I can combine index laws to simplify expressions. e.g. Simplify the following.</p> <p>a $x(-xy^2)^3$ b $\left(\frac{a^2b^3}{2}\right)^2 \times \frac{4}{(ab)^2}$</p>	✓
7E	<p>14 I can express negative indices in positive index form. e.g. Rewrite the following with positive indices only:</p> <p>a $4x^{-2}$ b $\frac{5}{2^{-3}}$</p>	
7E	<p>15 I can evaluate expressions involving negative indices. e.g. Write the following with a positive index and then as a fraction.</p> <p>a 5×2^{-3} b 4×10^{-2}</p>	
7F	<p>16 I can convert from scientific notation to a basic numeral. e.g. Write these numbers as a basic numeral:</p> <p>a 4.9×10^3 b 3.01×10^{-6}</p>	
7F	<p>17 I can write numbers using scientific notation. e.g. Write these numbers using scientific notation:</p> <p>a 27 000 b 0.0000375</p>	
7G	<p>18 I can write numbers using scientific notation and rounding to a given number of significant figures. e.g. Write these numbers in scientific notation using three significant figures:</p> <p>a 9 143 000 b 0.00032</p>	
7G	<p>19 I can use a calculator to evaluate expressions involving numbers expressed with scientific notation. e.g. Use a calculator to evaluate $\frac{\sqrt{5.3 \times 10^{-3}}}{8.32 \times 10^{-2}}$ and express your answer using four significant figures.</p>	

Short-answer questions

7A 1 Express each of the following in index form.

a $3 \times 3 \times 3 \times 3$

b $2 \times x \times x \times x \times y \times y$

c $3 \times a \times a \times a \times \frac{b}{a} \times b$

d $\frac{3}{5} \times \frac{3}{5} \times \frac{3}{5} \times \frac{1}{7} \times \frac{1}{7}$

7A 2 Write the following as a product of prime factors in index form.

a 45

b 300

7B 3 Simplify using index laws 1 and 2.

a $x^3 \times x^7$

b $2a^3b \times 6a^2b^5c$

c $3m^2n \times 8m^5n^3$

d $a^{12} \div a^3$

e $x^5y^3 \div (x^2y)$

f $\frac{5a^8b^3}{10a^6b}$

7C/7D 4 Simplify:

a $(m^2)^3$

b $(3a^4)^2$

c $(-2a^2b)^5$

d $3a^0b$

e $2(3m)^0$

f $\left(\frac{a^2}{3}\right)^3$

7E 5 Express each of the following with positive indices.

a 2^{-3}

b 3×4^{-5}

c 6×10^{-3}

d $\frac{1}{4^{-2}}$

e $\frac{6}{5^{-3}}$

f $\frac{2}{10^{-5}}$



7B/7C/7D 6 Use index laws to simplify each of the following.

a $\frac{k^5 \times k^3}{k^2}$

b $\frac{9a^4}{2m^3} \times \frac{4m^4}{3a^2}$

c $(a^2)^3 \times 4a^4$

d $(h^{12})^3 \div (h^4)^5$

e $\frac{4(a^3)^2(b^4)^3}{20a^0(b^2)^5}$

f $5(3p^2q)^2$

7F 7 Write each of the following numbers as a basic numeral to arrange in ascending order. $2.35, 0.007 \times 10^2, 0.0012, 3.22 \times 10^{-1}, 0.4, 35.4 \times 10^{-3}$.

7F 8 Write each of the following numbers as a basic numeral.

a 3.24×10^2

b 1.725×10^5

c 2.753×10^{-1}

d 1.49×10^{-3}

7G 9 Write each of the following values using scientific notation correct to three significant figures.

a The population of Australia in 2010 was approximately 22 475 056.

b The area of the USA is 9 629 091 km².

c The time taken for light to travel 1 metre (in a vacuum) is 0.000000003333564 seconds.

d The wavelength of ultraviolet light is 0.000000294 m.

7F 10 Write each of the following values using scientific notation in the units given in brackets. Note: 1 tonne = 1000 kg.

a 25 years (hours)

b 3 million years (months)

c 430 tonnes (kg)

d 5 tonnes (grams)

Multiple-choice questions

7B 1 $3x^7 \times 4x^4$ is equivalent to:

A $12x^7$

B $12x^{28}$

C $7x^{11}$

D $12x^{11}$

E $7x^3$

7C 2 $3(2y^2)^0$ simplifies to:

A 6

B 3

C $6y^2$

D 3y

E 12

7D 3 $(2x^2)^3$ expands to:

A $2x^5$

B $2x^6$

C $6x^6$

D $8x^5$

E $8x^6$

7B 4 $\frac{x^6y^2}{4x^2y}$ simplifies to:

- A $-4x^4y$ B $\frac{x^3y^2}{4}$ C $\frac{x^4y}{4}$ D $\frac{x^4y^2}{4}$ E $\frac{x^3y}{4}$

7D 5 $\left(\frac{2a}{k}\right)^3$ is equal to:

- A $\frac{2a^3}{k}$ B $\frac{2a^3}{k^3}$ C $\frac{6a^3}{k^3}$ D $\frac{8a^3}{k^3}$ E $\frac{6a}{3k}$

7D 6 $\left(\frac{5^2}{7^3}\right)^4$ is equal to:

- A $\frac{4 \times 5^2}{4 \times 7^3}$ B $\frac{5^8}{7^{12}}$ C $\frac{5^6}{7^3}$ D $\frac{5^8}{7^3}$ E $\frac{5^6}{7^7}$

7D 7 $5(2am^3)^3$ is equal to:

- A $30a^3m^9$ B $10a^3m^9$ C $40a^3m^6$ D $40a^3m^9$ E $10am^6$

7E 8 4×7^{-3} expressed with positive indices is:

- A 28^3 B 4^37^3 C $\frac{4}{7^3}$ D $\frac{-4}{7^3}$ E $\frac{1}{4 \times 7^3}$

7F 9 The weight of a cargo crate is 2.32×10^4 kg. In expanded form this weight in kilograms is:

- A 2 320 000 B 232 C 23 200 D 0.000232 E 2320

7G 10 0.00032761 using scientific notation rounded to three significant figures is:

- A 328×10^{-5} B 3.27×10^{-4} C 3.28×10^4 D 3.30×10^4 E 3.28×10^{-4}

Extended-response questions

1 Use a calculator to evaluate the following, giving your answer using scientific notation correct to two significant figures.



a $m_s \times m_e$ where m_s (mass of Sun) = 1.989×10^{30} kg and m_e (mass of Earth) = 5.98×10^{24} kg.

b The speed, v , in m/s of an object of mass $m = 2 \times 10^{-3}$ kg and kinetic energy

$$E = 1.88 \times 10^{-12} \text{ joules where } v = \sqrt{\frac{2E}{m}}$$

2 Use the table of Solar System data below to answer these questions. Express each answer using scientific notation rounded to three significant figures.



Approximate data for some planets in the Solar System			
Planet	Distance from the Sun in millions of km	Length (in Earth days) of one revolution around the Sun	Mass compared to Earth
Mercury	57.9	88.0	0.553
Venus	108.2	224.7	0.815
Earth	149.6	365.25	1.00
Mars	227.9	687.0	0.1074
Jupiter	778.3	4331	317 896
Saturn	1427	10 760	95 185

a Find the distance from the Sun, in km, for:

- i Mercury ii Earth iii Jupiter iv Saturn

b How many Earth years will have passed for these planets to complete one full revolution around the Sun?

- i Mercury ii Mars iii Saturn

c The mass of Earth is approximately 5.98×10^{24} kg. Determine the mass of:

- i Venus ii Mars iii Jupiter

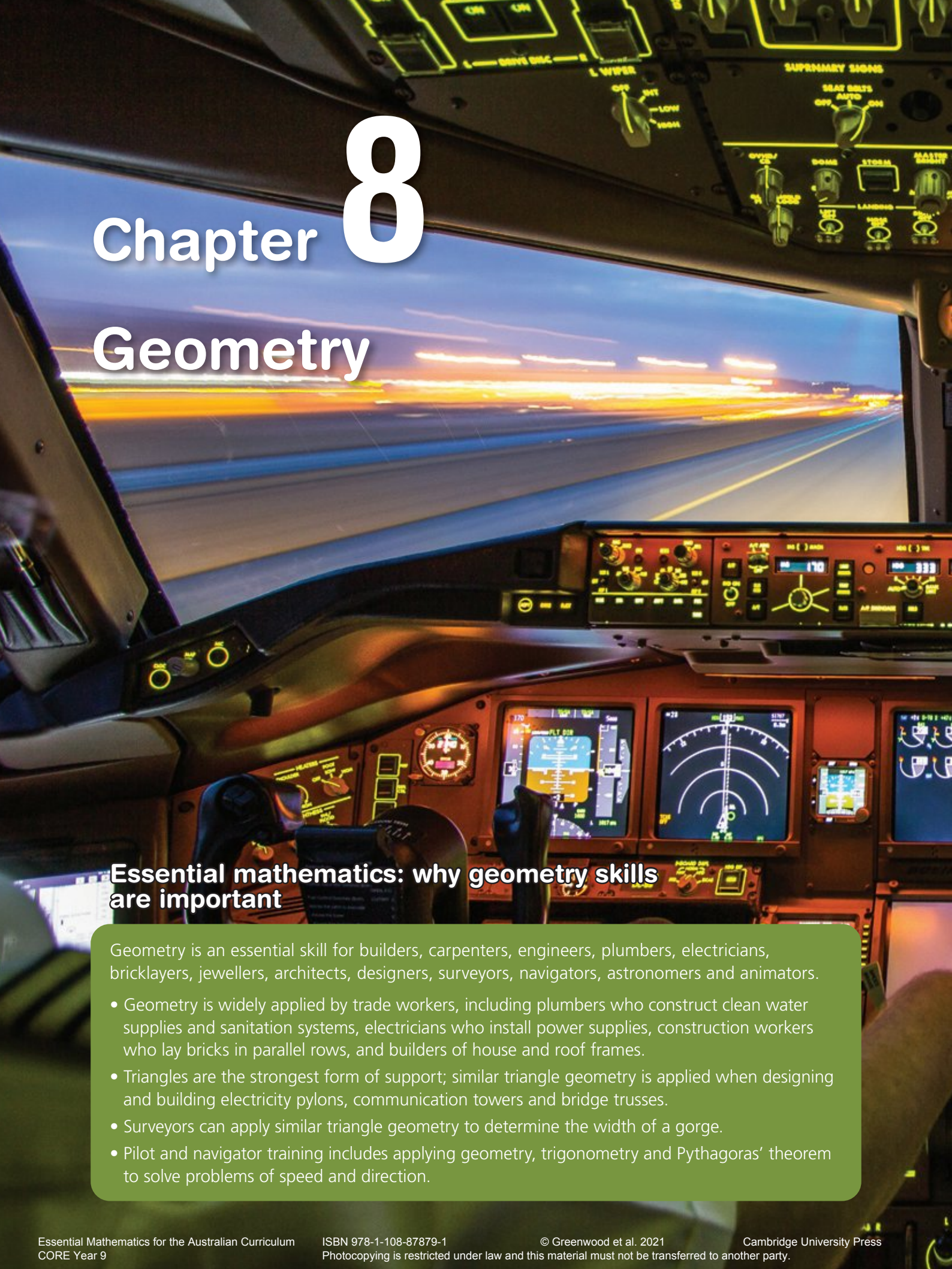

Chapter 8

Geometry

Essential mathematics: why geometry skills are important

Geometry is an essential skill for builders, carpenters, engineers, plumbers, electricians, bricklayers, jewellers, architects, designers, surveyors, navigators, astronomers and animators.

- Geometry is widely applied by trade workers, including plumbers who construct clean water supplies and sanitation systems, electricians who install power supplies, construction workers who lay bricks in parallel rows, and builders of house and roof frames.
- Triangles are the strongest form of support; similar triangle geometry is applied when designing and building electricity pylons, communication towers and bridge trusses.
- Surveyors can apply similar triangle geometry to determine the width of a gorge.
- Pilot and navigator training includes applying geometry, trigonometry and Pythagoras' theorem to solve problems of speed and direction.



In this chapter

- 8A Angles and triangles
(Consolidating)
- 8B Parallel lines (Consolidating)
- 8C Quadrilaterals (Consolidating)
- 8D Polygons ★
- 8E Congruent triangles
- 8F Enlargement and similar figures
- 8G Similar triangles
- 8H Applying similar triangles

Australian Curriculum

MEASUREMENT AND GEOMETRY

Geometric reasoning

Use the enlargement transformation to explain similarity and develop the conditions for triangles to be similar (ACMMG220)

Solve problems using ratio and scale factors in similar figures (ACMMG221)

© Australian Curriculum, Assessment and Reporting Authority (ACARA)

Online resources

A host of additional online resources is included as part of your Interactive Textbook, including HOTmaths content, video demonstrations of all worked examples, auto-marked quizzes and much more.

1 Name the following types of angles. Choose from *acute*, *right*, *obtuse*, *straight*, *reflex* or *revolution*.

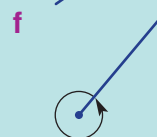
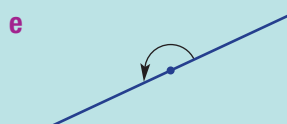
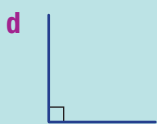
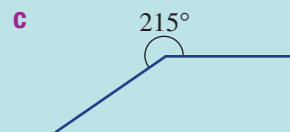
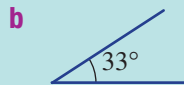
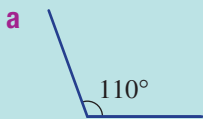

2 Find the value of a .

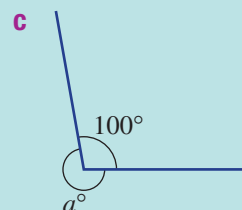
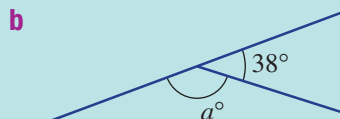
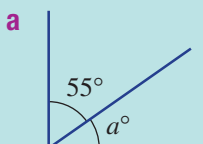

3 Identify the following triangles as *equilateral*, *isosceles* or *scalene*.

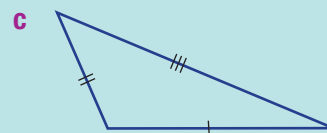
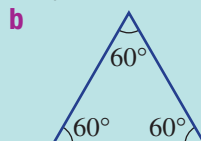
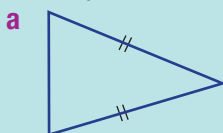

4 Identify the following as *right*, *acute* or *obtuse* triangles.

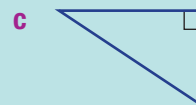

5 Find any missing angles in these triangles.

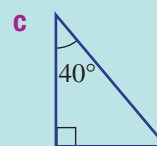
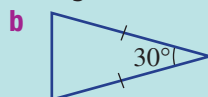
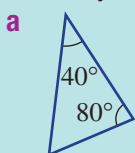

6 Of the six special quadrilaterals (square, rectangle, parallelogram, rhombus, kite and trapezium), which ones match the following descriptions?

a Two pairs of equal length sides

b Two pairs of parallel sides

c Equal length diagonals

7 Find the value of the pronumerals in each of the following.

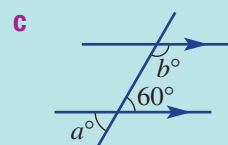
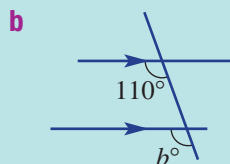
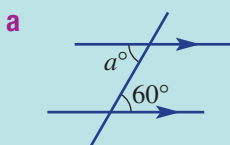

8 Name the following shapes.

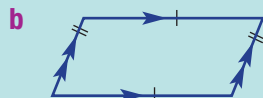
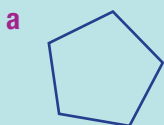

8A Angles and triangles

CONSOLIDATING

Learning intentions

- To review the various types of angles and triangles
- To know the special relationships between angles formed at a point
- To be able to find missing angles in simple geometric diagrams including angles at a point and triangles
- To be able to use the exterior angle theorem for a triangle

Key vocabulary: line, line segment, angle, complementary, supplementary, revolution, vertically opposite, acute, right, obtuse, reflex, straight, angle sum, scalene, isosceles, equilateral, exterior angle, triangle

When looking at a building or structure, we see angles formed where two lines meet. We also see triangles being used for their strength and rigidity. Angles associated with triangles and with lines that meet at a point will be revised in this section.



→ Lesson starter: Exterior angle discovery

Here is a triangle with one side extended to form the exterior angle $\angle BCD$ with size c° .

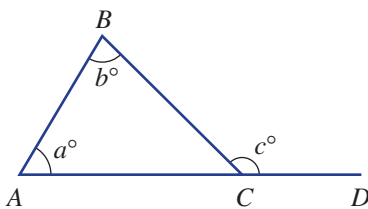

- 1 If $a = 50$ and $b = 85$, find $\angle ACB$. Then find $\angle BCD$. What do you notice?
- 2 Repeat for $a = 60$ and $b = 95$. What do you notice?
- 3 What is the relationship between a, b and c ? This is called the exterior angle theorem.

Key ideas

- When two lines or line segments meet at a point, an **angle** is formed.

- This angle (shown here) is named $\angle A$ or $\angle BAC$ or $\angle CAB$
- The size of the angle is a° .
- A common tool used for measuring an angle is a protractor.

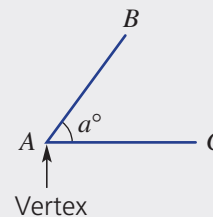

- Angle types

- **Acute:** between 0° and 90°
- **Right:** 90°
- **Obtuse:** between 90° and 180°
- **Straight:** 180°
- **Reflex:** between 180° and 360°
- **Revolution:** 360°

- Angles at a point

- **Complementary** (sum to 90°)

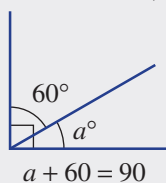

- **Supplementary** (sum to 180°)

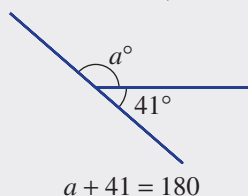



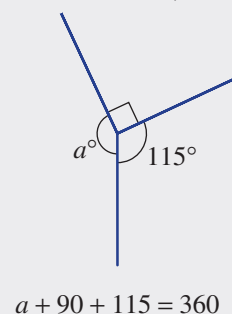

- **Revolution** (sum to 360°)

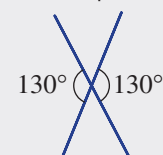

- **Vertically opposite** (are equal)

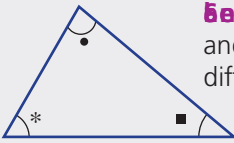

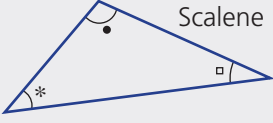
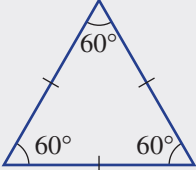
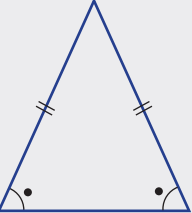
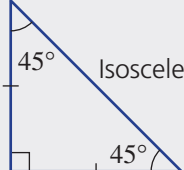
Types of triangles

Acute-angled (all angles $< 90^\circ$)	Right-angled (includes a 90° angle)	Obtuse-angled (one angle $> 90^\circ$)
 <p>Scalene (all sides and angles are different sizes)</p>	 <p>Scalene</p>	 <p>Scalene</p>
 <p>Equilateral (all angles 60° and all sides equal)</p>  <p>Isosceles (two angles equal and two sides equal)</p>	 <p>Isosceles</p>	 <p>Isosceles</p>

- The sum of the angles in a triangle (**angle sum**) is 180° .

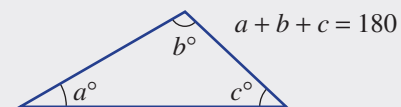

- An **exterior angle** is formed by extending one side of a shape.

- Exterior angle theorem of a triangle: The exterior angle of a triangle is equal to the sum of the two opposite interior angles.

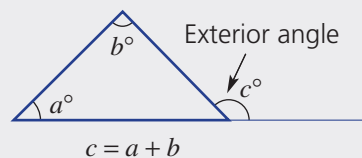

Exercise 8A

Understanding

1–3

2, 3

- 1 Choose a word or number to complete each sentence.

- a** A 90° angle is called a ____ angle. **b** A ____ angle is called a straight angle.
c A 360° angle is called a _____. **d** ____ angles are between 90° and 180° .
e ____ angles are between 0° and 90° . **f** Reflex angles are between ____ and 360° .
g Complementary angles sum to _____. **h** ____ angles sum to 180° .
i The three angles in a triangle sum to _____. **j** Vertically opposite angles are _____.

- 2 What type of triangle has:

- a** a pair of equal length sides? **b** one obtuse angle?
c all angles 60° ? **d** one pair of equal angles?
e all angles acute? **f** all sides of different length?
g one right angle? **h** two 45° angles?

- 3 Estimate the size of each of the following angles and use your protractor to determine an accurate measurement.

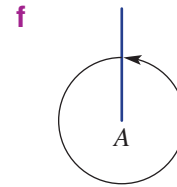
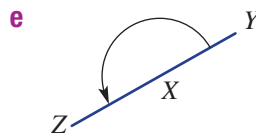
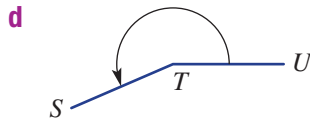
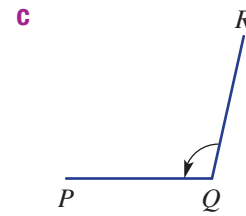
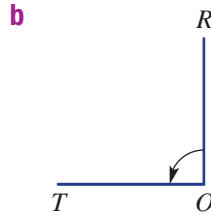
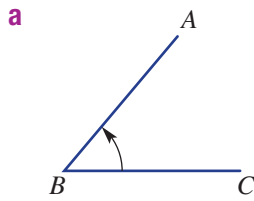

Fluency

4(½), 5, 6(½)

4–6(½)



Example 1 Finding supplementary and complementary angles

For the angle 47° , determine the:

a supplementary angle

b complementary angle

Solution

a $180^\circ - 47^\circ = 133^\circ$

b $90^\circ - 47^\circ = 43^\circ$

Explanation

Supplementary angles sum to 180° .

Complementary angles sum to 90° .

Now you try

For the angle 74° , determine the:

a supplementary angle

b complementary angle

- 4 For each of the following angles determine:

i the supplementary angle

ii the complementary angle

a 55°

b 31°

c 74°

d 10°

e 89°

f 22°

g 38°

h 65°

i 47°

j 77°

- 5 Find the value of a in these diagrams.

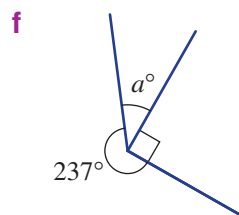
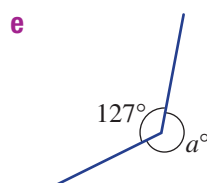
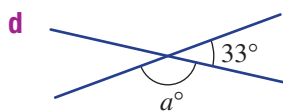
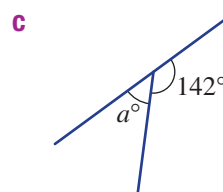
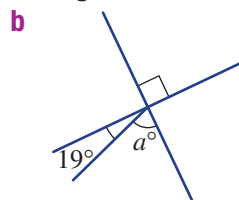
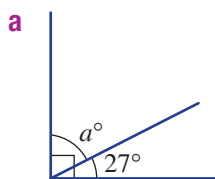

Hint:

- Supplementary angles add to 180° .
- Complementary angles add to 90° .



Hint:

- A straight angle is 180° .
- A revolution is 360° .



8A

Example 2 Finding unknown angles in triangles

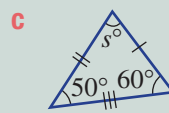
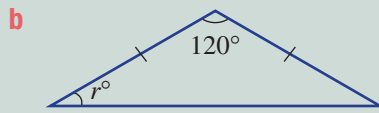
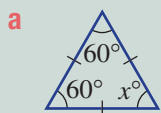

Name the types of triangles shown here. Determine the values of the pronumerals.

**Solution**

a Equilateral triangle
 $x = 60$

b Obtuse isosceles triangle
 $2r + 120 = 180$
 $2r = 60$
 $r = 30$

c Acute scalene triangle
 $s + 50 + 60 = 180$
 $s + 110 = 180$
 $s = 70$

Explanation

All sides are equal, therefore all angles are equal.

One angle is more than 90° and two sides are equal.

Angles in a triangle add to 180° and since it is isosceles the two base angles are equal. Subtract 120 from both sides and then divide both sides by 2.

All angles are less than 90° and all sides are of different length.

Angles in a triangle add to 180° . Simplify and solve for s .

Now you try

Name the types of triangles shown here. Determine the values of the pronumerals.

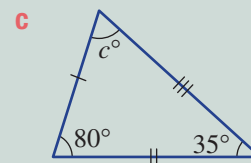
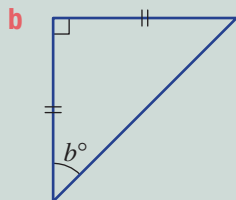
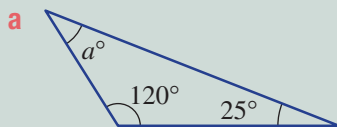

6 Name the types of triangles shown here. Determine the values of the pronumerals.

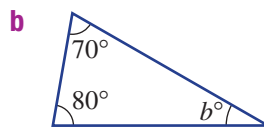
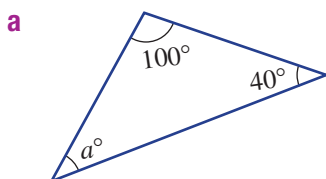

Hint: The angle sum of a triangle is 180° .

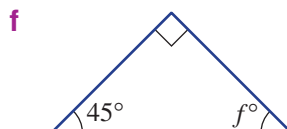
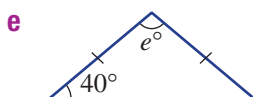
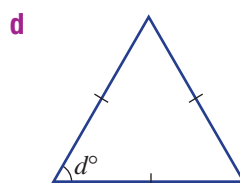
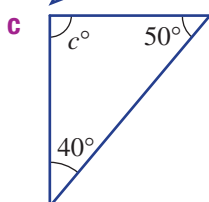

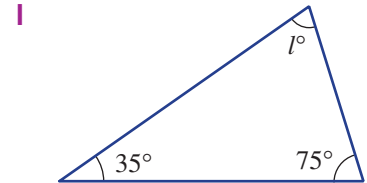
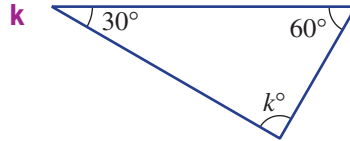
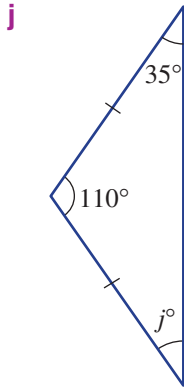
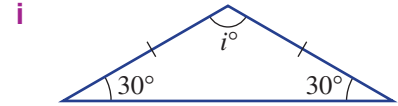
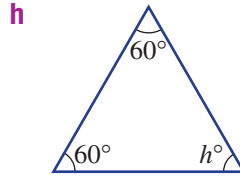
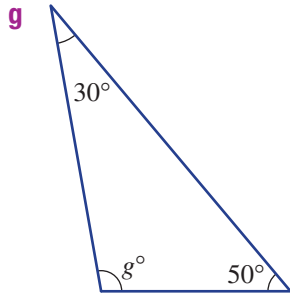

Problem-solving and reasoning

7, 8

7-8(½), 9

7 For each diagram:

- i** name the angle shown (e.g. $\angle ABC$)
- ii** state the type of angle given
- iii** estimate the size of the angle
- iv** measure the angle using a protractor.

Hint: When naming an angle, put the letter at the vertex in the middle.

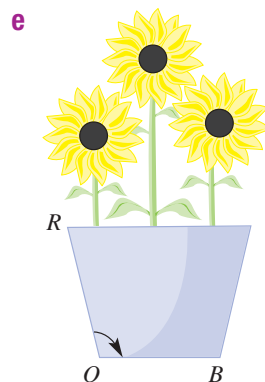
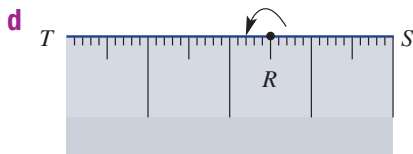
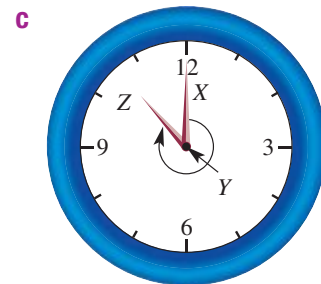
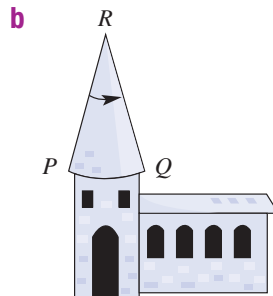
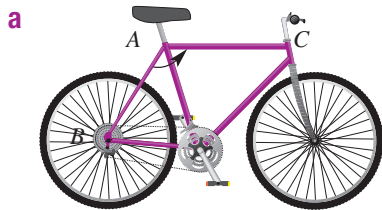
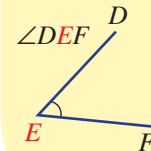

8A

Example 3 Finding angles outside a triangle



Find the value of each pronumeral. Give reasons for your answers.

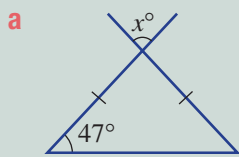

Solution

a $x + 47 + 47 = 180$ (angle sum)
 $x + 94 = 180$
 $x = 86$

b Let a be the unknown angle.
 $a + 90 + 55 = 180$ (angle sum)
 $a = 35$
 $y + 35 = 180$
 $y = 145$

Alternative method: $y = 90 + 55$
 $= 145$



Explanation

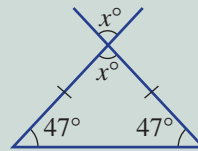

Note the isosceles triangle and vertically opposite angles and mark in those angles. Angles in a triangle add to 180° and vertically opposite angles are equal. Simplify and solve for x .

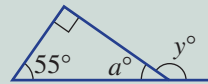

Angles in a straight line are supplementary (sum to 180°).

Alternatively, use the exterior angle theorem which says that the exterior angle is equal to the sum of the two opposite interior angles.

Now you try

Find the value of each pronumeral. Give reasons for your answers.

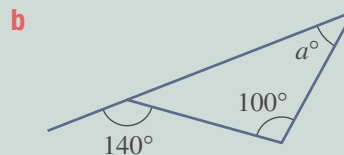
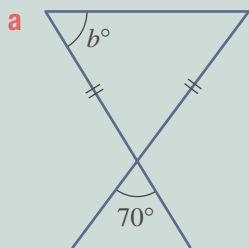

8 Find the value of each pronumeral.

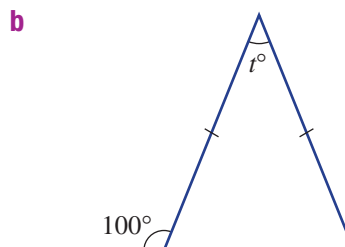
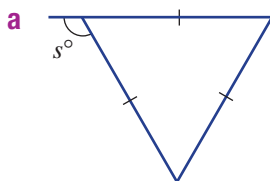

Hint: If you can't find the value of the pronumeral straight away, try finding one of the other unknown angles.



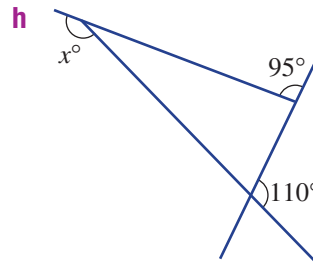
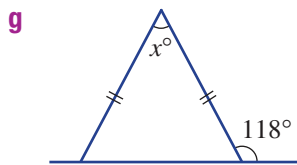
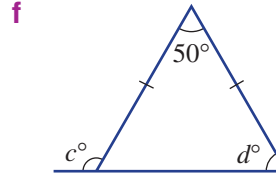
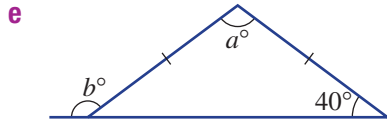
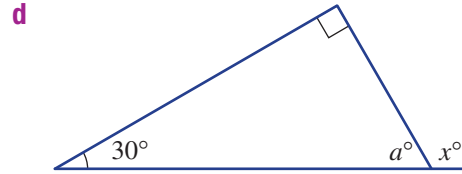
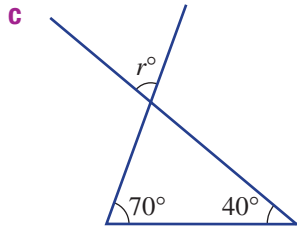

- 9 Explain why $\angle OAB$ is 32° in this circle if O marks the centre of the circle.

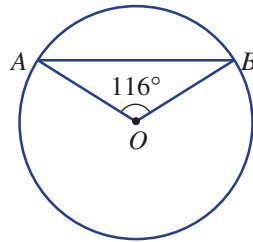

Analogue geometry

—

10, 11

- 10 Calculate how many degrees the minute hand of a clock rotates in:

- a** 1 hour **b** $\frac{1}{4}$ of an hour **c** 10 minutes **d** 15 minutes
e 72 minutes **f** 1 minute **g** 2 hours **h** 1 day

- 11 Find the non-reflex angle between the hour and minute hands at these times. Remember to consider how the hour hand moves between each whole number. For example, at 9.30, the hour hand is halfway between the 9 and 10.

- a** 3 p.m. **b** 5 a.m.
c 6:30 p.m. **d** 11:30 p.m.
e 3:45 a.m. **f** 1:20 a.m.
g 4:55 a.m. **h** 2:42 a.m.



8B Parallel lines

CONSOLIDATING

Learning intentions

- To know the special pairs of angles formed when a transversal cuts two other lines
- To know the relationship between pairs of angles formed when a pair of parallel lines is cut by a transversal
- To be able to calculate unknown angles associated with parallel lines

Key vocabulary: parallel, transversal, corresponding, alternate, cointerior, vertically opposite, supplementary

When two lines are crossed by a third line, called a transversal, many special pairs of angles are formed. If the two original lines are parallel, then the pairs of angles are either equal or they add to 180° .

→ Lesson starter: Are they parallel?

Here are three diagrams that show a transversal crossing two other lines.

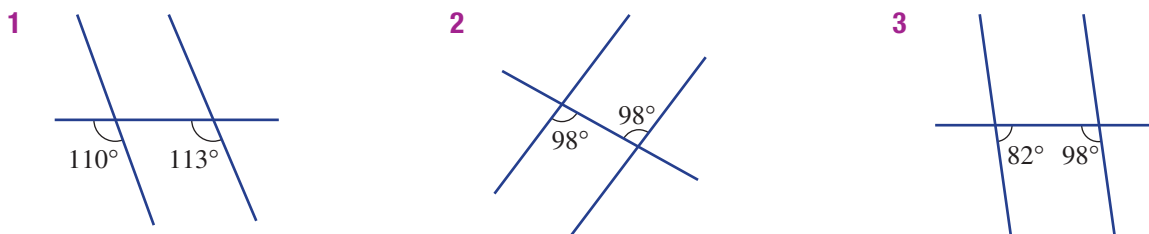

Decide whether each diagram contains a pair of parallel lines. Give reasons for your answer.

Key ideas

- Parallel lines point in the same direction.
 - Arrows indicate that lines are parallel.
- A **transversal** is a line crossing two or more other lines.

Special pairs of angles	Non-parallel lines	Parallel lines
Corresponding angles <ul style="list-style-type: none"> • If lines are parallel, corresponding angles are equal. 		
Alternate angles <ul style="list-style-type: none"> • If lines are parallel, alternate angles are equal. 		
Cointerior angles <ul style="list-style-type: none"> • If lines are parallel, cointerior angles are supplementary (sum to 180°). 		

Exercise 8B

Understanding

1, 2

2

1 Decide whether the pair of marked angles are corresponding, alternate or cointerior.

a

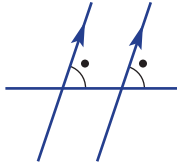

b

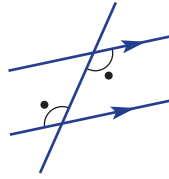

c

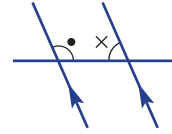

d

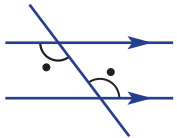

e

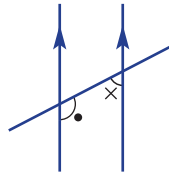

f

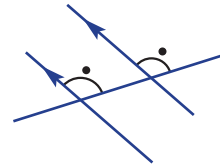

2 Use the word *equal* or *supplementary* to complete these sentences.

- a If two lines are parallel, corresponding angles are _____.
 b If two lines are parallel, alternate angles are _____.
 c If two lines are parallel, cointerior angles are _____.

Hint: Supplementary angles add to 180° .



Fluency

3–4(½), 5

3–5(½)



Example 4 Deciding whether lines are parallel

Decide whether each diagram contains a pair of parallel lines. Give a reason.

a

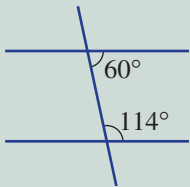

b

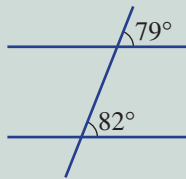

c

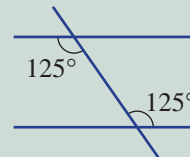

Solution

- a No. The two cointerior angles do not add to 180° .
 b No. The two corresponding angles are not equal.
 c Yes. The two alternate angles are equal.

Explanation

$$60^\circ + 114^\circ = 174^\circ \neq 180^\circ$$

$$79^\circ \neq 82^\circ$$

If alternate angles are equal then the lines are parallel.

Now you try

Decide whether each diagram contains a pair of parallel lines. Give a reason.

a

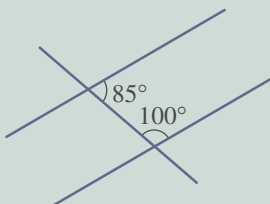

b

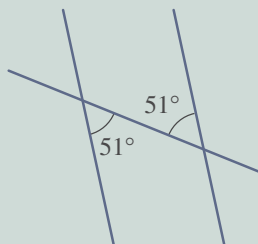

c

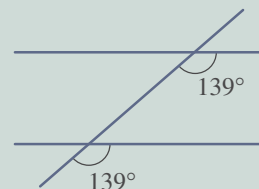

8B

3 Decide if each diagram contains a pair of parallel lines. Give a reason.

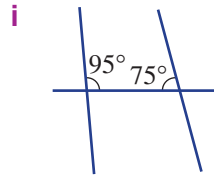
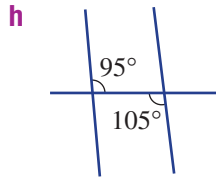
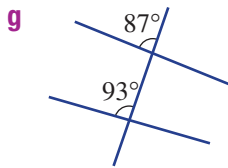
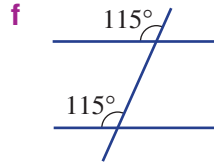
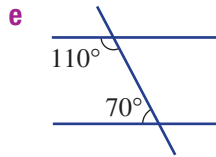
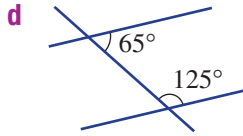
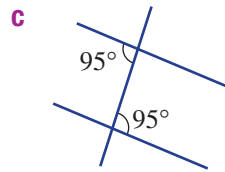
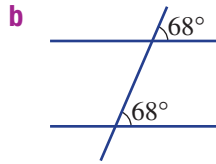
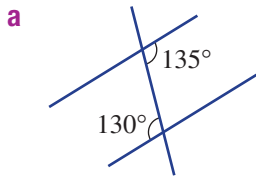

Hint: The reasons why lines could be parallel include:

- Corresponding angles are equal.
- Alternate angles are equal.
- Cointerior angles add to 180° (are supplementary).



Example 5 Finding angles in parallel lines

Find the value of each of the pronumerals. Give reasons for your answers.

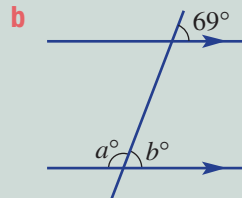
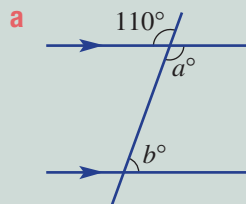

Solution

a $a = 110$ (vertically opposite angles)

$$b + 110 = 180 \text{ (cointerior angles in parallel lines)}$$

$$b = 70$$

b $b = 69$ (corresponding angles in parallel lines)

$$a + 69 = 180 \text{ (supplementary angles)}$$

$$a = 111$$

Explanation

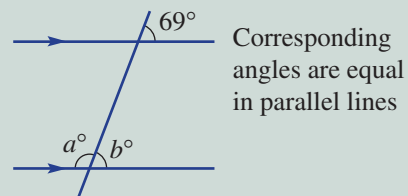
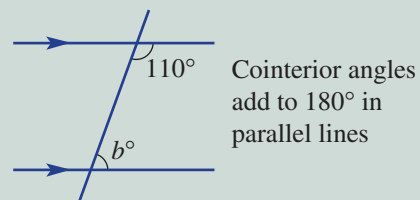
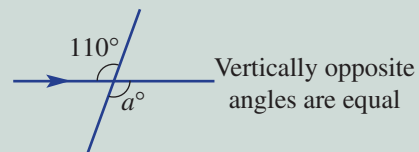

Supplementary angles add to 180° so $a + b = 180$.

Now you try

Find the value of each of the pronumerals. Give reasons for your answers.

a

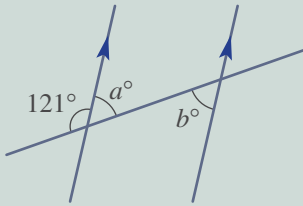

b

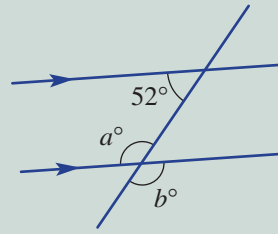

4 Find the values of the pronumerals. Give a reason for each answer.

a

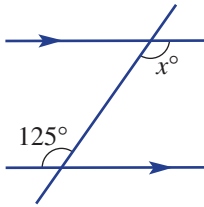

b

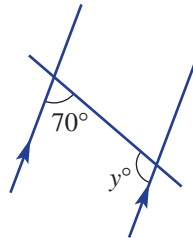

Hint: For part a, $x = 125$.
Reason: Alternate angles in parallel lines. Other reasons include corresponding angles in parallel lines or cointerior angles in parallel lines.



c

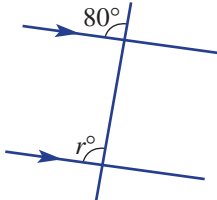

d

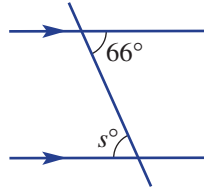

e

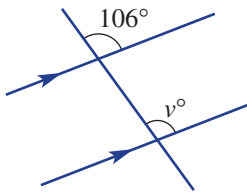

f

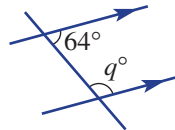

5 Find the value of each pronumeral. Give reasons for your answers.

a

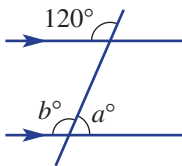

b

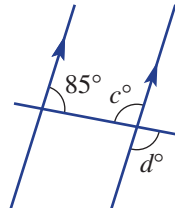

c

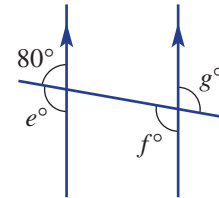

d

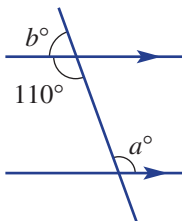

e

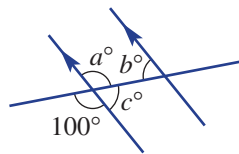

f

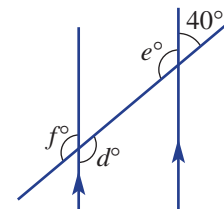

Problem-solving and reasoning

6, 7

7, 8

- 6 Two pairs of train tracks meet at 40° , as shown. Find the value of a, b, c, d and e .

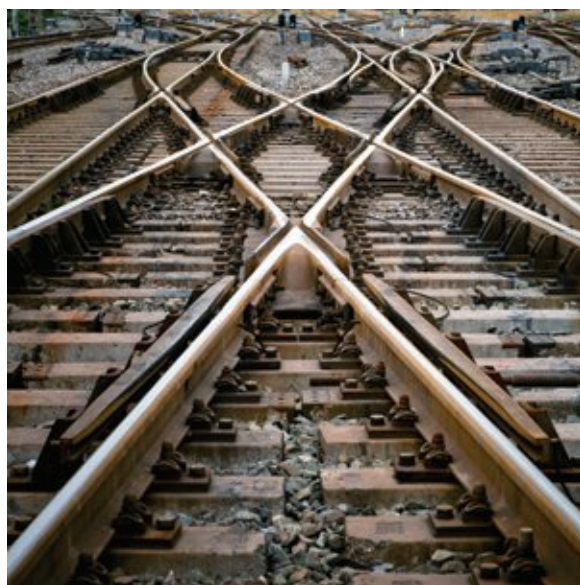
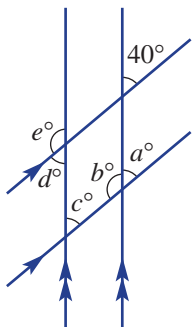

- 7 Find the value of each pronumeral.

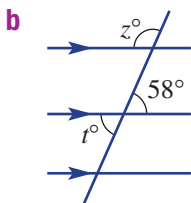
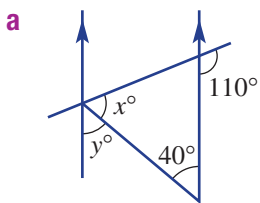

Hint: Look for pairs of angles inside parallel lines. Mark in all known missing angles to help find the value of the pronumeral.

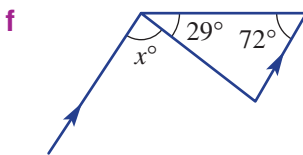
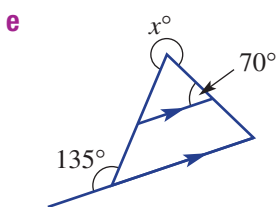
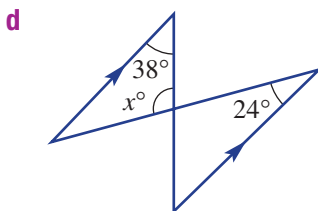
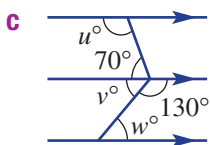

- 8 Find the value of x .

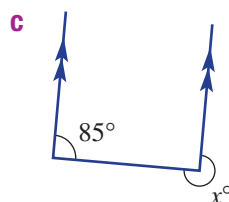
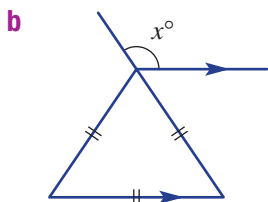
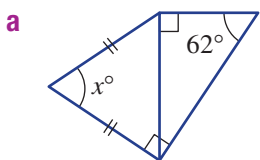

Hint: Use all the given information to mark in any missing angles.





Add a new line to help

9

- 9 Sometimes you can add a third parallel line to a diagram to help you find an angle. For example, to find $\angle ABC$ in this diagram you can draw a parallel line through B , then find the two alternate angles (30° and 70°). So $\angle ABC = 30^\circ + 70^\circ = 100^\circ$.

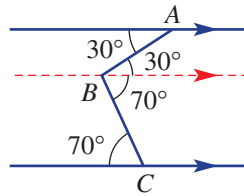

Add a third parallel line to help find $\angle ABC$ in these diagrams.

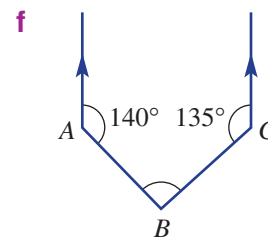
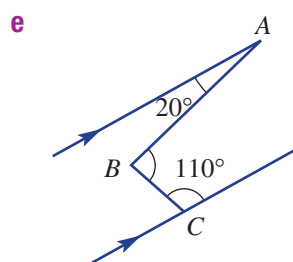
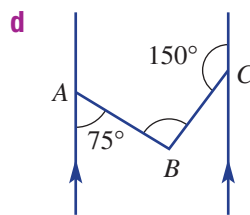
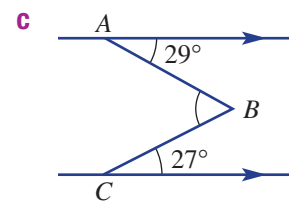
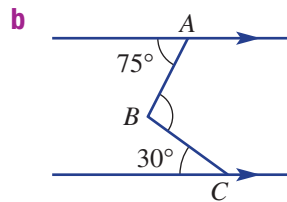
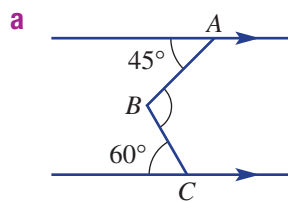

8C Quadrilaterals

CONSOLIDATING

Learning intentions

- To know the properties of special quadrilaterals
- To know the angle sum of a quadrilateral
- To be able to calculate unknown angles inside a quadrilateral

Key vocabulary: quadrilateral, parallelogram, square, rectangle, rhombus, trapezium, kite, diagonal, parallel

Quadrilaterals are polygons with four straight sides. They include six special shapes, four of which are types of parallelograms. Like triangles, they have a special angle sum. This sum is the same for all types of quadrilaterals.



→ Lesson starter: What is a parallelogram?

A parallelogram is a four-sided shape made from two pairs of parallel lines.

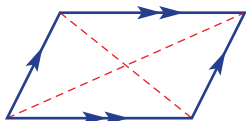

- What are some properties of a parallelogram?
- Do you think the following shapes are parallelograms?
 - Rectangle
 - Kite
 - Rhombus
 - Square
 - Trapezium
- Discuss the properties of each of the special quadrilaterals. Consider side lengths, the lengths of diagonals and the interior angles.

Key ideas

- **Quadrilaterals** are four-sided plane figures with straight sides.
- **Parallelograms** are quadrilaterals with two pairs of parallel sides.

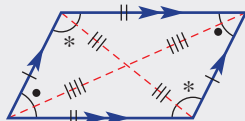

They include:

- **Rectangle**

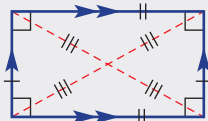

- **Rhombus**

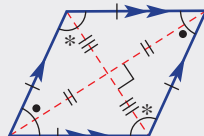

- **Square**

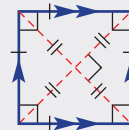

The red dashed lines are called the **diagonals**.

- The kite and trapezium are also special quadrilaterals.

- Kite**

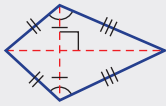

- Trapezium**

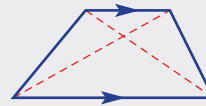

- The angle sum of a quadrilateral is 360° .

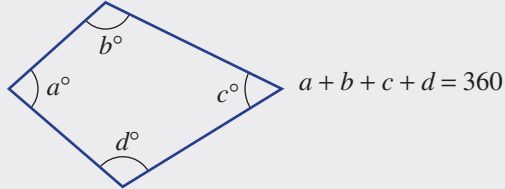

- Supplementary cointerior angles add to 180° .

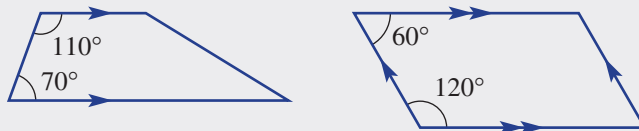

Exercise 8C

Understanding

1–3

3

- Name the six special quadrilaterals.
- A parallelogram has two pairs of parallel sides. Decide whether the following are parallelograms.

a Rhombus	b Kite	c Rectangle
d Square	e Trapezium	
- Write the word to complete these sentences.
 - A parallelogram has two pairs of _____ sides.
 - The diagonals in a rhombus intersect at _____ angles.
 - A quadrilateral with one pair of parallel sides is called a _____.
 - The diagonals in a rectangle are _____ in length.

Fluency

4, 5–6(½)

4, 5–6(½)



Example 6 Working with properties of quadrilaterals

Name all the types of quadrilaterals that have these properties.

- Equal length diagonals
- Diagonals intersecting at right angles

Solution

Explanation

- Rectangle and square

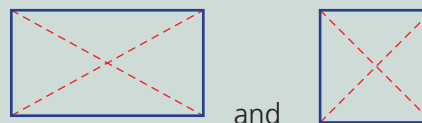

and

- Rhombus, square and kite

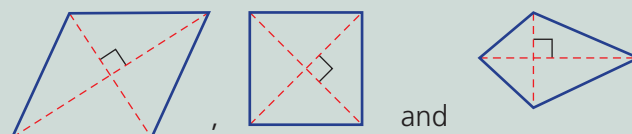

and

Continued on next page

8C

Now you try

Name all the types of quadrilaterals that have these properties.

- a** Equal opposite side lengths **b** Exactly one pair of equal opposite angles.

4 List all the quadrilaterals that have these properties.

- a** 2 pairs of equal length sides
b All interior angles 90°
c Diagonals of equal length
d Diagonals intersecting at right angles
e 1 pair of parallel sides
f Diagonals of different length

Hint: Refer to the diagrams in the Key Ideas for help.



Example 7 Finding angles in quadrilaterals

Find the value of the pronumeral in this quadrilateral.

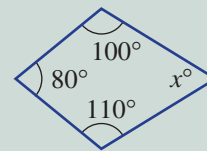
**Solution**

$$\begin{aligned}x + 80 + 100 + 110 &= 360 \\x + 290 &= 360 \\x &= 70\end{aligned}$$

Explanation

The angles in a quadrilateral add to 360° .
Simplify and solve for x .

Now you try

Find the value of the pronumeral in this quadrilateral.

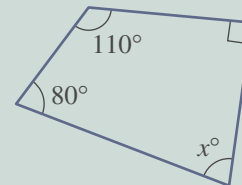

5 Find the value of the pronumeral x in these quadrilaterals.

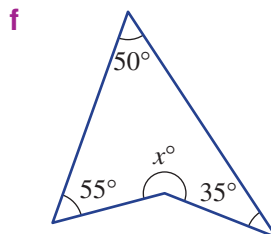
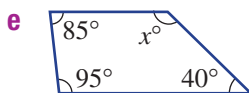
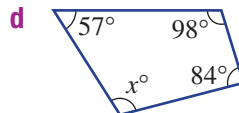
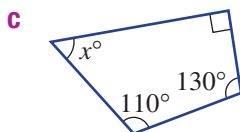
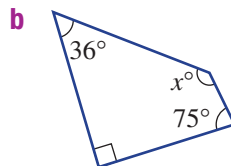
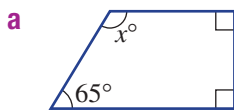

Hint: Use the angle sum of a quadrilateral, which is 360° .





Example 8 Finding angles in special quadrilaterals

Find the value of the pronumeral in this kite and trapezium.

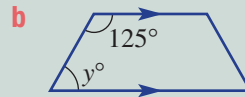
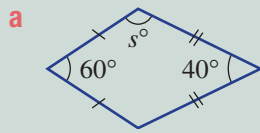

Solution

a

$$2s + 60 + 40 = 360$$

$$2s + 100 = 360$$

$$2s = 260$$

$$s = 130$$

b

$$y + 125 = 180$$

$$y = 55$$

Explanation

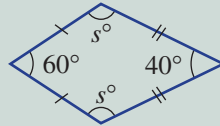

The angles in a quadrilateral add to 360° and the opposite angles (s°) are equal in a kite.

Cointerior angles inside parallel lines are supplementary (add to 180°).

Now you try

Find the value of the pronumeral in this kite and trapezium.

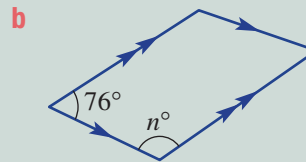
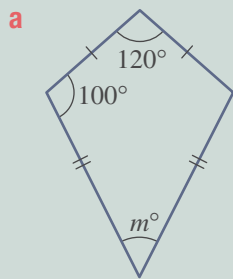

6 Find the value of the pronumerals.

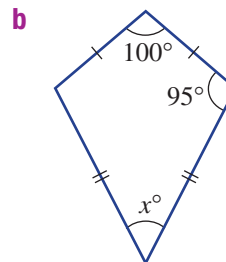
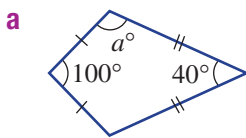

Hint: Remember: A kite has one pair of equal opposite angles. Cointerior angles inside parallel lines are supplementary (add to 180°).

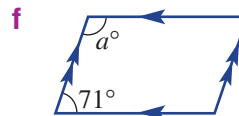
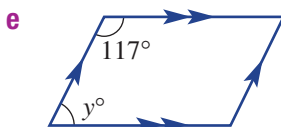
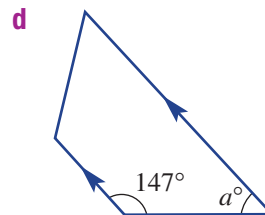
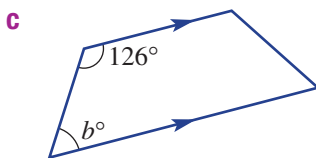

Problem-solving and reasoning

7, 8

7, 9, 10

- 7 Decide whether it is possible to draw a quadrilateral with:
- 1 interior reflex angle
 - 2 interior reflex angles
 - 3 acute angles
 - 4 acute angles
- 8 A shopping centre's floor is a quadrilateral with one 120° angle and two 90° angles. What is the size of the fourth angle?
- 9 Explain why a rectangle, square and rhombus are all parallelograms.
- 10 These quadrilaterals include exterior angles. Find the value of x in each.

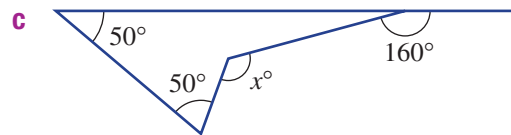
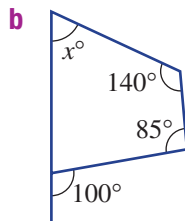
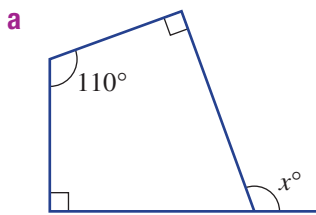
Quad x challenge

—

11

- 11 Find the value of x in these diagrams.

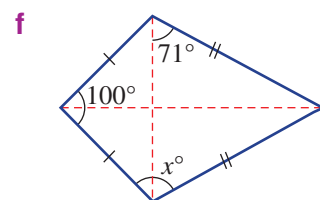
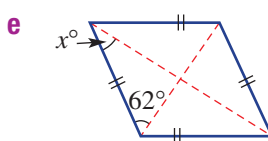
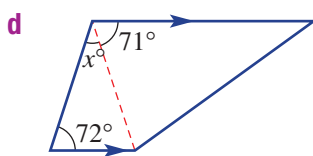
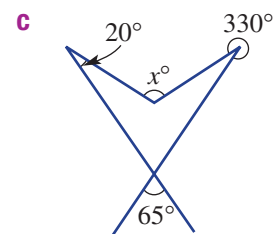
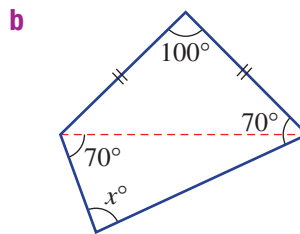
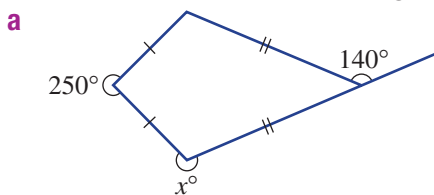

8D Polygons

Learning intentions

- To know the rule for the angle sum of a polygon
- To be able to calculate unknown angles inside a polygon
- To be able to calculate the interior angle of regular polygons

Key vocabulary: polygon, regular polygon, convex, non-convex

Closed two-dimensional shapes with straight sides are called polygons. They are classified by their number of sides. We have already studied triangles (3 sides) and quadrilaterals (4 sides), which have been classified further by their special properties. The properties of other polygons will be studied here.

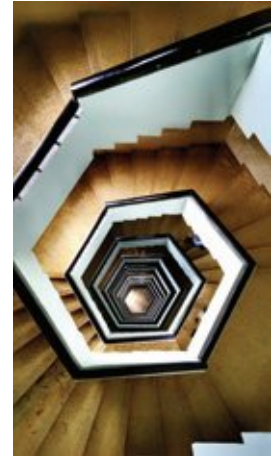

Lesson starter: Can you draw a polygon?

Use your knowledge of polygons to draw each of the following shapes.

- a convex quadrilateral (all angles less than 180°)
- a non-convex pentagon (at least one angle greater than 180°)
- a regular hexagon (all sides and all angles equal)

Key ideas

- A **polygon** is a closed two-dimensional shape with straight sides.
- **Convex** polygons have all interior angles less than 180° . A **non-convex** polygon has at least one interior angle greater than 180° .

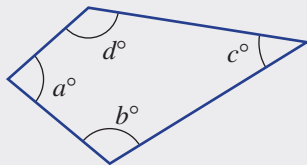

Convex quadrilateral

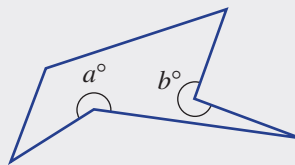

Non-convex hexagon

- The sum of the interior angles, S , in a polygon with n sides is given by $S = 180(n - 2)$

Polygon	Number of sides	Angle sum
Triangle	3	180°
Quadrilateral	4	360°
Pentagon	5	540°
Hexagon	6	720°
Heptagon	7	900°
Octagon	8	1080°
Nonagon	9	1260°
Decagon	10	1440°
Undecagon	11	1620°
Dodecagon	12	1800°
n -gon	n	$180(n-2)^\circ$

8D

- **Regular polygons** have equal length sides and equal interior angles.

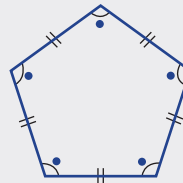

A regular pentagon

Exercise 8D

Understanding

1–4

4

- 1 Write the missing word/rule.

- a A _____ has 6 sides.
- b A _____ polygon has equal sides and equal angles.
- c A _____ polygon has at least one reflex angle.
- d The rule for the angle sum of a polygon is $S =$ _____.

- 2 How many sides do these polygons have?

- a Pentagon
- b Heptagon
- c Quadrilateral
- d Undecagon
- e Nonagon
- f Dodecagon

Hint: Refer to the Key Ideas for help.



- 3 Use $S = 180(n - 2)$ to find the angle sum, S , of these polygons. n is the number of sides.

- a Hexagon
- b Octagon
- c Undecagon
- d Heptagon

- 4 Name each of these shapes as convex or non-convex, and write their polygon name.

a

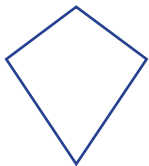

b



c

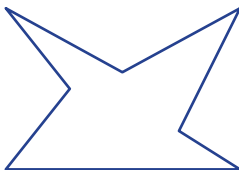

d

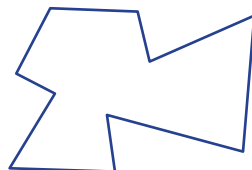

Hint: A convex polygon has all internal angles less than 180° .



Fluency

5-7(1/2)

5-7(1/2)

5 Find the value of x using the given angle sum.

a

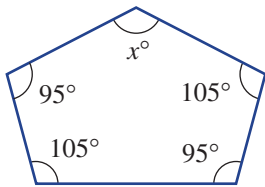
Angle sum = 540°

b

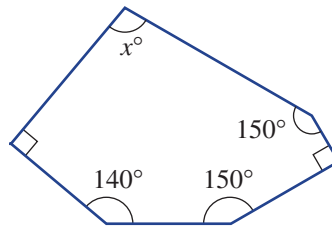
Angle sum = 720°

c

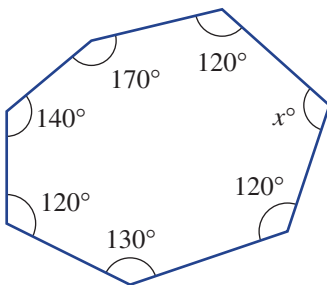
Angle sum = 900°

d

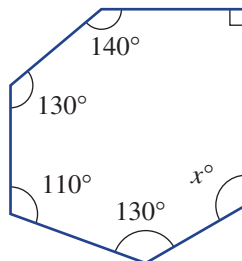
Angle sum = 720°

Hint: All the angles must sum to the given angle sum.



Example 9 Finding angles in polygons

Find the angle sum using $S = 180(n - 2)$, then find the value of a .

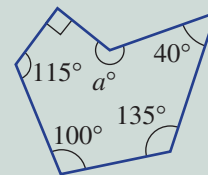

Solution

$$\begin{aligned} n &= 6 \text{ and } S = 180(n - 2) \\ &= 180(6 - 2) \\ &= 180 \times 4 \\ &= 720 \end{aligned}$$

$$\begin{aligned} a + 90 + 115 + 100 + 135 + 40 &= 720 \\ a + 480 &= 720 \\ a &= 240 \end{aligned}$$

Explanation

The shape is a hexagon with 6 sides so $n = 6$.

The sum of all angles is 720° . Simplify and solve for a .

Now you try

Find the angle sum using $S = 180(n - 2)$, then find the value of a .

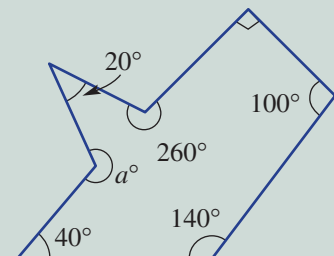

8D



6 For each polygon find the angle sum using $S = 180(n - 2)$. Then find the value of a .

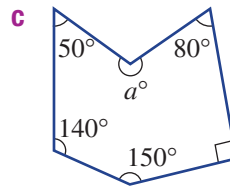
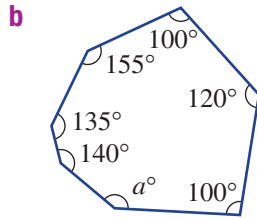
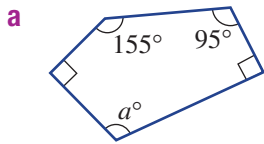

Hint: First find the angle sum using $S = 180(n - 2)$, where n is the number of sides.

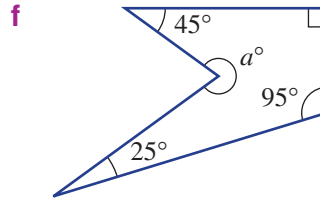
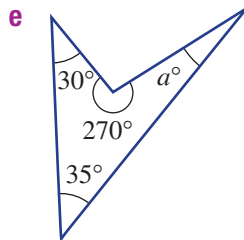
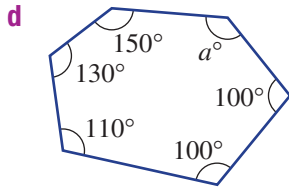

Example 10 Working with regular polygons

Find the size of an interior angle of a regular octagon.

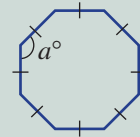

Solution

$$\begin{aligned} n &= 8 \text{ and } S = 180(n - 2) \\ &= 180(8 - 2) \\ &= 1080 \\ a &= 1080 \div 8 \\ &= 135 \end{aligned}$$

Explanation

The regular octagon has 8 sides so use $n = 8$.

Each interior angle in a regular polygon is equal so divide by 8 to get a single angle.

Now you try

Find the size of an interior angle of a regular decagon.

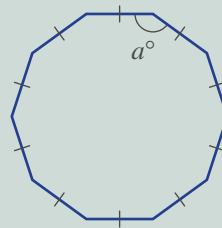

7 Find the size of an interior angle of these regular polygons. Round to two decimal places in part e.

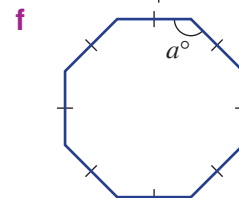
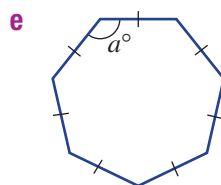
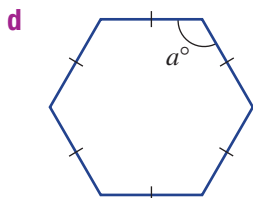
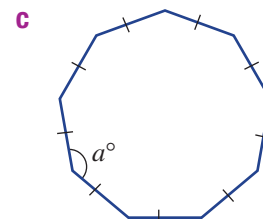
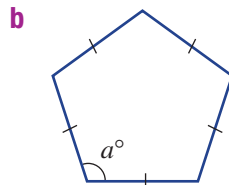
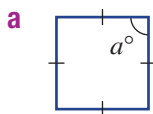

Problem-solving and reasoning

8, 9

8–10

- 8 Calculate the number of sides if a polygon has the given angle sum.
Suggestion: Use the rule $S = 180(n - 2)$.
- a 2520° b 4140° c $18\,000^\circ$
- 9 Decide whether the following are possible. If so, make a drawing.
- a A hexagon with all angles equal but not all sides equal.
b A hexagon with all sides equal but not all angles equal.

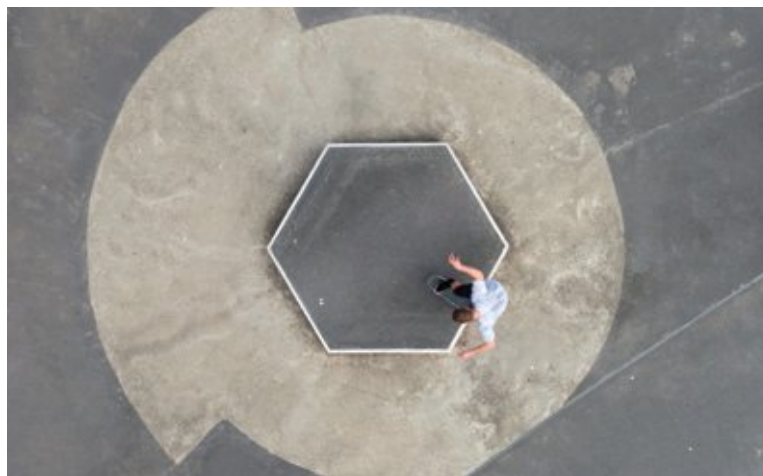

- 10 These polygons include exterior angles. Find the value of x in each.

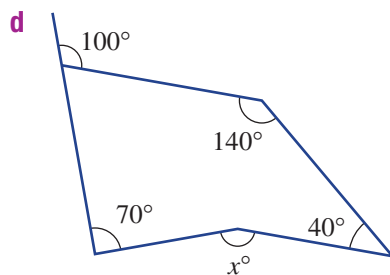
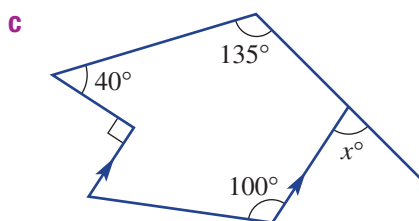
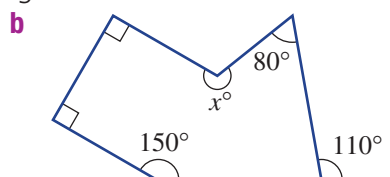
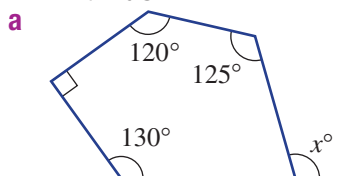

Hint: The interior angle sum will first need to be calculated.



Maximum reflex

—

11

- 11 Recall that a non-convex polygon has at least one reflex interior angle.
- a Use drawings to decide whether the following are possible.
- i A quadrilateral with 2 reflex angles.
ii A pentagon with 2 reflex angles
iii A hexagon with 4 reflex angles
- b What is the maximum number of interior reflex angles possible for these polygons?
- i Quadrilateral ii Pentagon iii Octagon
- c Write a rule for the maximum number of interior reflex angles for a polygon with n sides.

8E Congruent triangles

Learning intentions

- To understand the four tests for congruence of triangles
- To be able to recognise a pair of congruent triangles using one of the four tests
- To be able to find unknowns in a pair of congruent triangles

Key vocabulary: congruent/congruent figures, corresponding sides, corresponding angles, congruence statement

Congruent shapes and objects have the same shape and size. Their matching angles are equal and their matching sides have the same length.

It is possible to determine whether or not two triangles are congruent by using four tests, which we call SSS, SAS, AAS and RHS.

Lesson starter: Constructing congruent triangles

For this task you will need a ruler, pencil and protractor. (You might also use compasses.) Divide these constructions up equally among the members of the class. Each group is to draw one of the following triangles, with the given properties.

- 1 Triangle ABC with $AB = 8$ cm, $AC = 5$ cm and $BC = 4$ cm
- 2 Triangle DEF with $DE = 7$ cm, $DF = 6$ cm and $\angle EDF = 40^\circ$
- 3 Triangle GHI with $GH = 6$ cm, $\angle IGH = 50^\circ$ and $\angle IHG = 50^\circ$
- 4 Triangle JKL with $\angle JKL = 90^\circ$, $JL = 5$ cm and $KL = 4$ cm
 - Compare all triangles with the vertices ABC . What do you notice? What does this say about two triangles that have three pairs of equal side lengths?
 - Compare all triangles with the vertices DEF . What do you notice? What does this say about two triangles that have two pairs of equal side lengths and the included angles equal?
 - Compare all triangles with the vertices GHI . What do you notice? What does this say about two triangles that have two equal corresponding angles and one corresponding equal length side?
 - Compare all triangles with the vertices JKL . What do you notice? What does this say about two triangles that have one right angle, the hypotenuse and one other corresponding equal length side?



The Petronas Twin Towers in Kuala Lumpur look congruent.

Key ideas

- **Congruent figures** have the same shape and size.

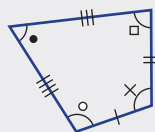
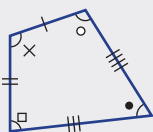

- If triangle ABC ($\triangle ABC$) is congruent to triangle DEF ($\triangle DEF$), we write $\triangle ABC \equiv \triangle DEF$. This is called a **congruence statement**.
 - Letters are usually written in matching order.

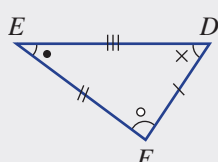
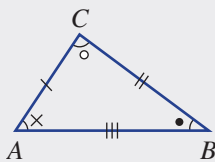

Corresponding sides	Corresponding angles
$AB = DE$	$\angle A = \angle D$
$BC = EF$	$\angle B = \angle E$
$AC = DF$	$\angle C = \angle F$

- **Corresponding sides** are opposite equal corresponding angles.

■ Tests for triangle congruence:

- Side, Side, Side (SSS)
Three pairs of corresponding sides are equal.



- Angle, Angle, Side (AAS)
Two angles and any pair of corresponding sides are equal.

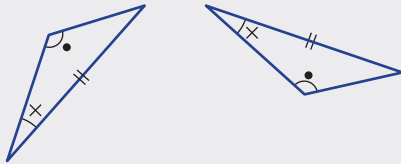

- Side, Angle, Side (SAS)
Two pairs of corresponding sides and the included angle are equal.

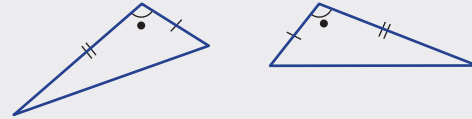

- Right angle, Hypotenuse, Side (RHS)
A right angle, the hypotenuse and one other pair of corresponding sides are equal.

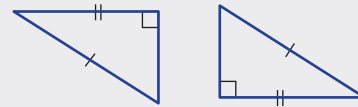

Exercise 8E

Understanding

1–3

2, 3(½)

- 1 These two triangles are congruent.

- a Name the point on $\triangle XYZ$ that matches:

- point B
- point A
- point C

- b Name the side on $\triangle XYZ$ that corresponds to (matches):

- AB
- AC
- BC

- c Name the angle in $\triangle ABC$ that corresponds to (matches):

- $\angle X$
- $\angle Y$
- $\angle Z$

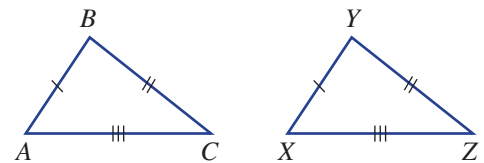

- 2 Copy and complete the sentences below.

- Congruent figures are exactly the same shape and _____.
- If triangle ABC is congruent to triangle STU then we write $\triangle ABC \equiv$ _____.
- The short names of the four congruence tests for triangles are SSS, _____, _____ and _____.

- 3 Write a congruence statement if:

- triangle ABC is congruent to triangle FGH
- triangle DEF is congruent to triangle STU

Hint: Example: $\triangle DEF \equiv \triangle GHI$





Example 11 Choosing a congruence test

Which congruence test (SSS, SAS, AAS or RHS) would be used to show that these pairs of triangles are congruent?

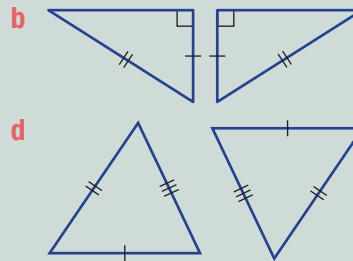
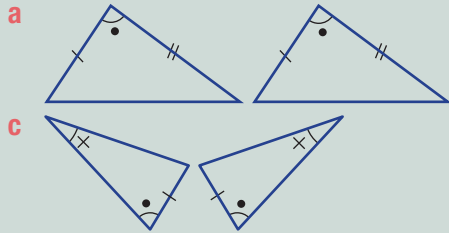

Solution

- a** SAS
b RHS
c AAS
d SSS

Explanation

- Two pairs of corresponding sides and the included angle are equal.
 A right angle, hypotenuse and one pair of corresponding sides are equal.
 Two angles and a pair of corresponding sides are equal.
 Three pairs of corresponding sides are equal.

Now you try

Which congruence test (SSS, SAS, AAS or RHS) would be used to show that these pairs of triangles are congruent?

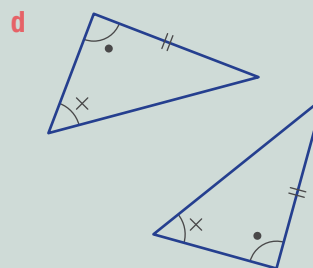
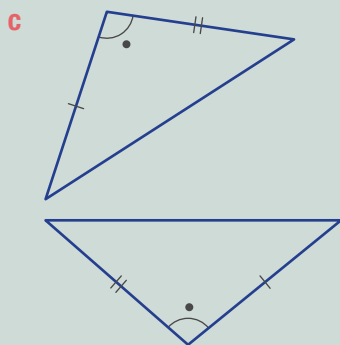
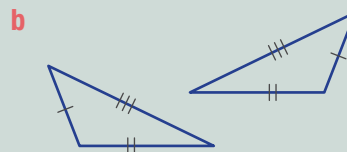
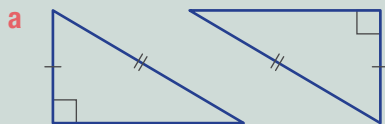

- 4 Which congruence test (SSS, SAS, AAS or RHS) would be used to show that these pairs of triangles are congruent?

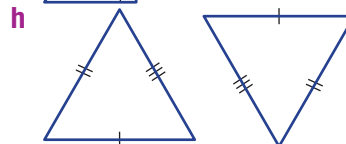
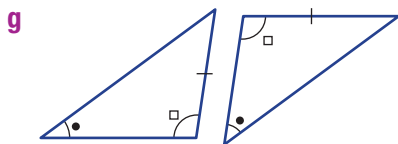
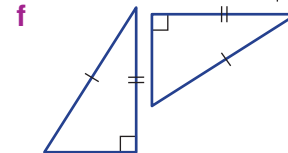
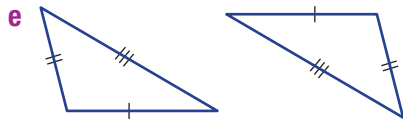
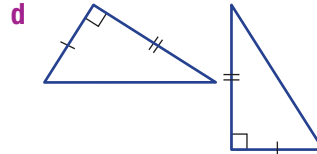
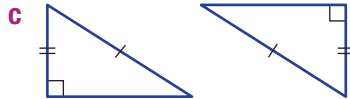
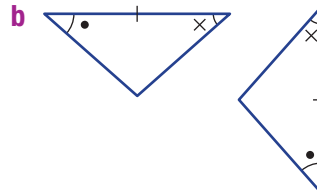
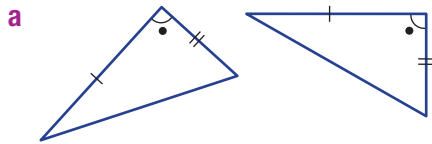

Hint: Choose SSS for three matching sides, SAS for two matching sides and the included angle, AAS for two equal angles and one matching side or RHS for a right angle, hypotenuse and one other matching side.



Example 12 Finding missing side lengths and angles using congruence

Find the values of the pronumerals in these pairs of congruent triangles.

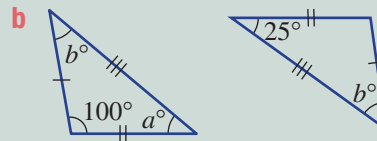
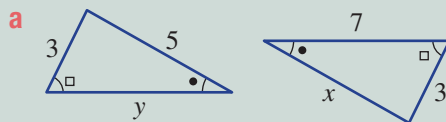

Solution

a $x = 5$

$y = 7$

b $a = 25$

$$b = 180 - 100 - 25 \\ = 55$$

Explanation

The side of length x and the side of length 5 are in corresponding positions (opposite the \square).

The longest side on both triangles must be equal.

The angle marked a° corresponds to the 25° angle in the other triangle.

The sum of three angles in a triangle is 180° .

Now you try

Find the values of the pronumerals in these pairs of congruent triangles.

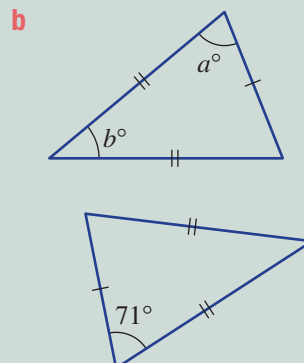
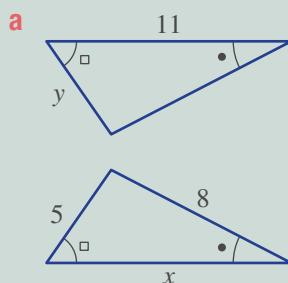

8E

5 Find the values of the pronumerals in these pairs of congruent triangles.

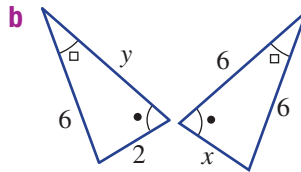
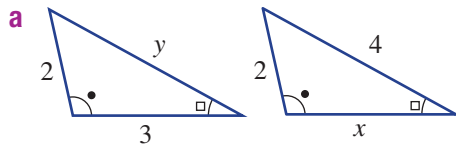

Hint: You already know they are congruent!

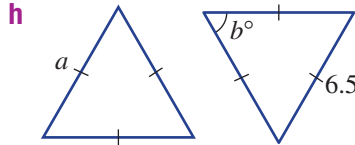
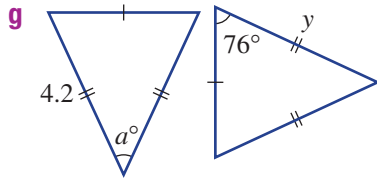
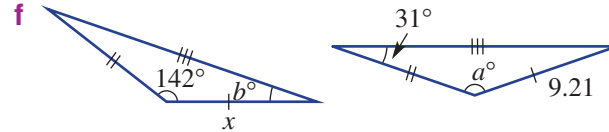
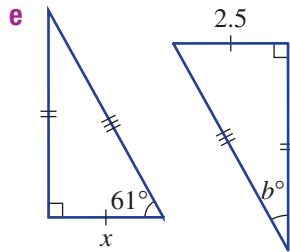
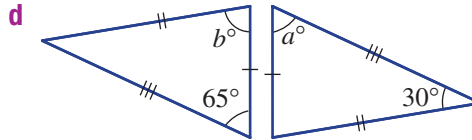
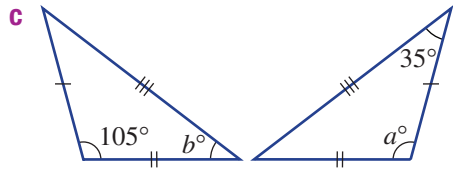

Problem-solving and reasoning

6-8

7-10

6 Measurements were taken for three matching triangular tiles and are shown here.

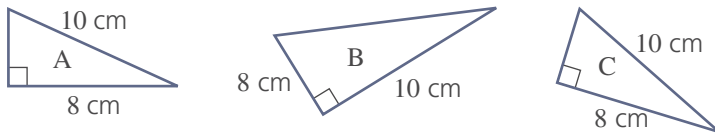

- a Which two triangles are congruent?
- b What reason (SSS, SAS, AAS, RHS) is used to explain their congruence?

7 For each set of three triangles, choose the two that are congruent. Give a reason (SSS, SAS, AAS or RHS) and write a congruence statement (e.g. $\triangle ABC \equiv \triangle FGH$).

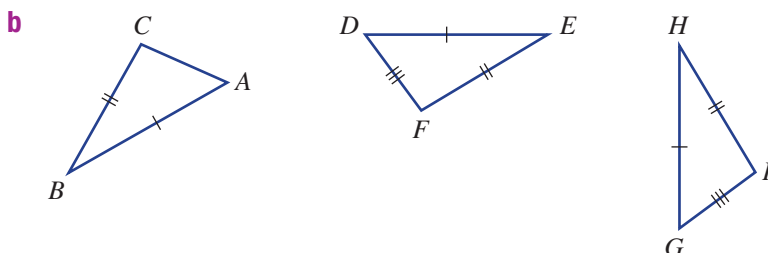
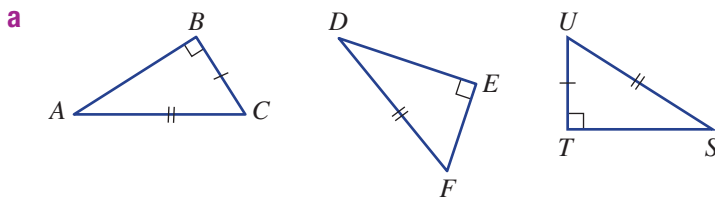

Hint: Write matching vertices in the same order.



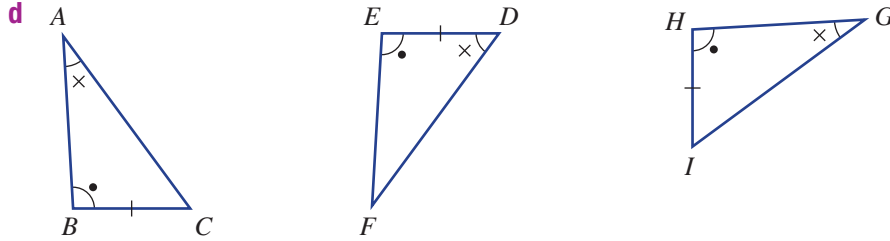
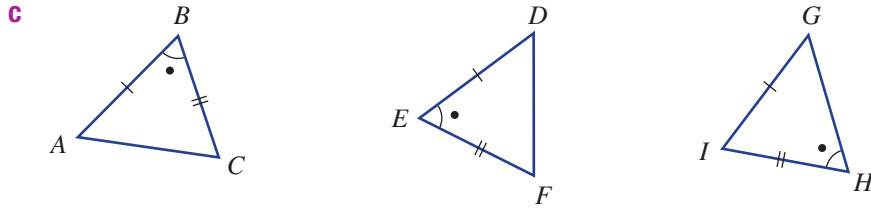

8 Explain why RHS is not the first reason you would use to explain why these two triangles are congruent.



9 Are all triangles with three pairs of equal corresponding angles congruent? Explain why or why not.

Hint: Draw examples to justify your decision.



- 10 $ABCD$ is a parallelogram.
a Give the reason why $\triangle ABC \cong \triangle CDA$.
b What does this say about $\angle B$ and $\angle D$?

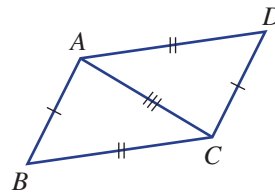

Fishing for congruence

—

11

11 Identify all pairs of congruent triangles from those below by writing a congruence statement. Angles with the same mark are equal.

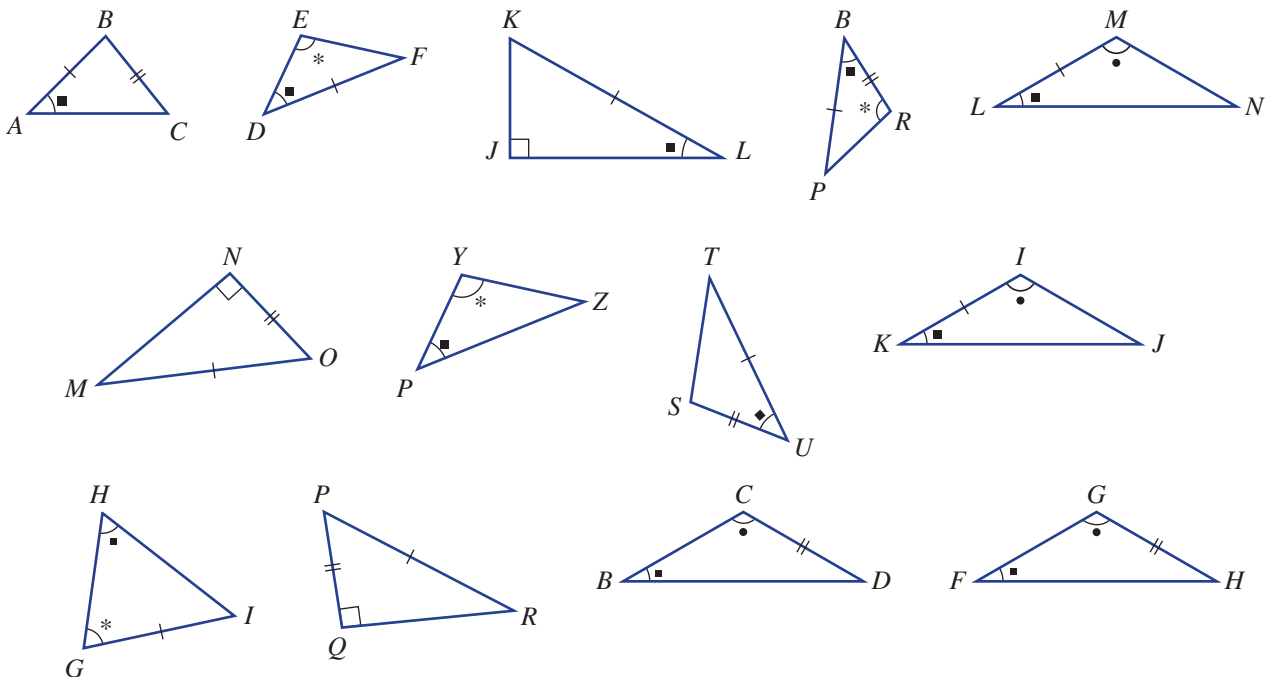

8A

1 For the angle 63° , determine the:

a complementary angle

b supplementary angle

8A

2 Name the types of triangles shown and find the value of each pronumeral. Part c includes an exterior angle.

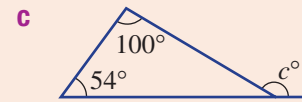
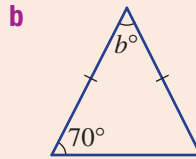
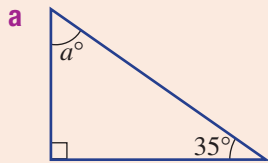

8B

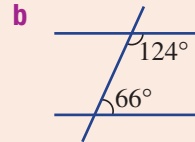
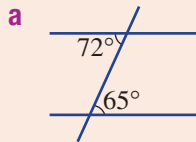
3 Explain why the pairs of lines shown below are *not* parallel.

8B

4 Find the values of the pronumerals in the parallel lines below. Give reasons for your answers.

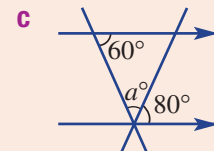
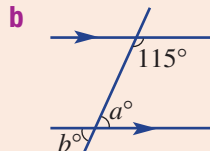
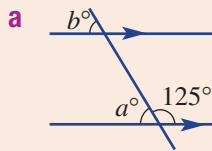

8C

5 Find the values of the pronumerals in these quadrilaterals and name the type of quadrilateral in parts b and c.

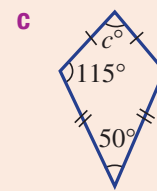
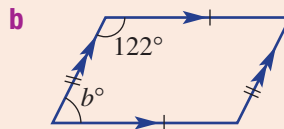
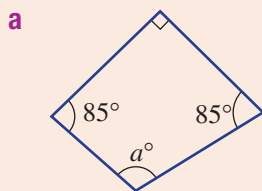

8D

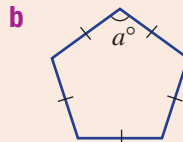
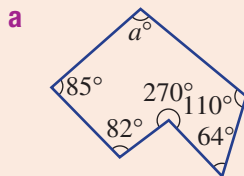
6 Find the angle sum of each of the following polygons using $S = 180(n - 2)$ and then find the value of a . The polygon in part b is a regular polygon.

8E

7 Which congruence test (SSS, SAS, AAS or RHS) would be used to show that these pairs of triangles are congruent?

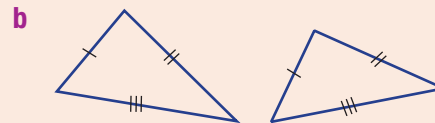
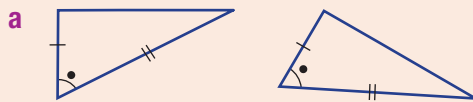

8E

8 Find the value of the pronumerals in this pair of congruent triangles.

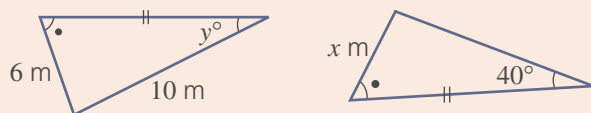

8F Enlargement and similar figures

Learning intentions

- To know that enlargement of a figure produces a similar figure
- To be able to recognise that two shapes are similar
- To be able to construct a similar figure using the enlargement transformation
- To be able to calculate a scale factor for similar figures
- To be able to find missing angles and side lengths in similar figures

Key vocabulary: similar figures, enlargement, scale factor, ratio, corresponding sides, corresponding angles, image

Whenever we look at a map, TV screen, microscope, model, movie screen or computer document we are looking at similar figures.

Similar figures have the same shape but not necessarily the same size. If two figures are similar then one of them can be enlarged or reduced so that it is identical (congruent) to the other. If a figure is enlarged by a scale factor greater than 1, the image will be larger than the original. If the scale factor is between 0 and 1, the image will be smaller.



→ Lesson starter: Are they similar?

Here are three quadrilaterals, not drawn to scale.

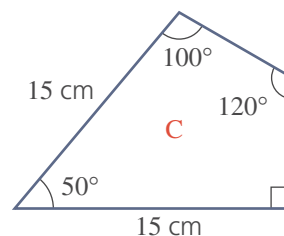
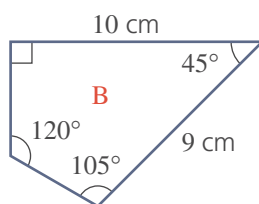
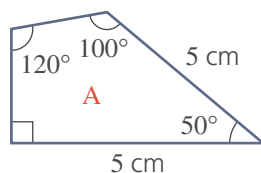

- Which pair of quadrilaterals do you think are similar?
- Why do you think they are similar? Discuss your reasons.
- Give reasons why the other quadrilateral is not similar.

Key ideas

- **Enlargement** is a transformation that involves the increase or decrease in size of an object.
 - The 'shape' of the object is unchanged.
 - Enlargement uses a centre of enlargement and an enlargement factor or **scale factor**.
 - The scale factor is the number by which you multiply each side length to enlarge or reduce the size of a shape.
 - The **image** of a point A can be labelled as A' .

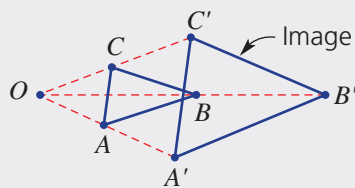

- Two figures are **similar** if one can be enlarged to be congruent to the other. They are of the same shape but not the same size.
 - Corresponding angles are equal.
 - Pairs of corresponding sides are in the same proportion or ratio.

8F

- The **scale factor** = $\frac{\text{image length}}{\text{original length}}$
- The symbols $|||$ and \sim are used to describe similarity.
 - For example, $ABCD ||| EFGH$ or $ABCD \sim EFGH$
 - The letters are usually written in matching order.
 - Scale factor = $\frac{EF}{AB} = \frac{10}{5} = 2$
 - The scale factor will be the same for all matching pairs of sides.

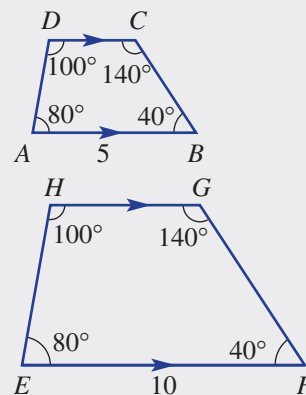

Exercise 8F

Understanding

1–4

1, 2, 4

- Write the missing word or symbol.
 - Scale factor = $\frac{\text{_____ length}}{\text{original length}}$
 - Similar shapes are the same _____ but different size.
 - If $ABCD$ is similar to $EFGH$, then we write $ABCD$ _____ $EFGH$.
- The two figures below are similar.
 - Name the angle in the larger figure that corresponds to (matches) $\angle A$.
 - Name the angle in the smaller figure that corresponds to $\angle I$.
 - Name the side in the larger figure that corresponds to BC .
 - Name the side in the smaller figure that corresponds to FJ .
 - Use FG and AB to find the scale factor.

Hint: For part e, use
scale factor = $\frac{\text{image length}}{\text{original length}}$

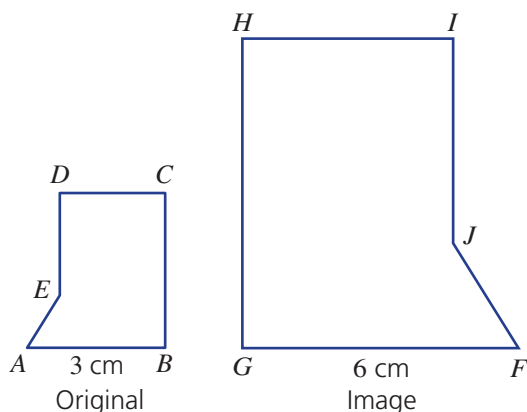

- This diagram shows $\triangle ABC$ enlarged to give the image $\triangle A'B'C'$.
 - Measure the lengths OA and OA' . What do you notice?
 - Measure the lengths OB and OB' . What do you notice?
 - Measure the lengths OC and OC' . What do you notice?
 - What is the scale factor?
 - Is $A'B'$ twice the length of AB ? Measure to check.

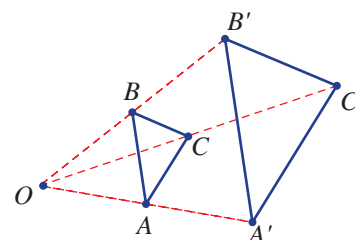

- 4 This diagram shows rectangle $ABCD$ enlarged (in this case reduced) to rectangle $A'B'C'D'$.

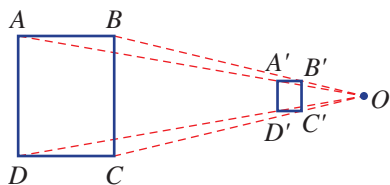

- Measure the lengths OA and OA' . What do you notice?
- Measure the lengths OD and OD' . What do you notice?
- What is the scale factor?
- Compare the lengths AD and $A'D'$. Is $A'D'$ one quarter of the length of AD ?

Fluency

5, 6

5(½), 6, 7



Example 13 Using the scale factor

These figures are similar.

- Find the scale factor.
- Find the value of x .
- Find the value of y .

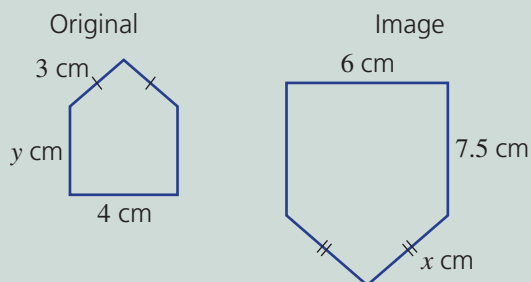

Solution

a Scale factor = $\frac{6}{4} = 1.5$

b $x = 3 \times 1.5$
 $= 4.5$

c $y \times 1.5 = 7.5$
 $y = 7.5 \div 1.5$
 $= 5$

Explanation

Choose two corresponding sides and use
scale factor = $\frac{\text{image length}}{\text{original length}}$

Multiply by the scale factor to get the length of the side on the larger image.

When y is multiplied by the scale factor it gives a length of 7.5 on the image. Divide by 1.5 to solve for y .

Now you try

These figures are similar.

- Find the scale factor.
- Find the value of x .
- Find the value of y .

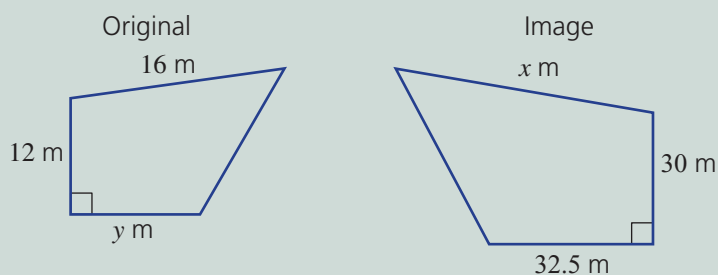

8F



5 Each of the pairs of figures shown here are similar. For each pair:

- Find the scale factor.
- Find the value of x .
- Find the value of y .

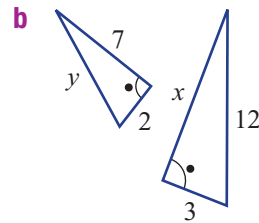
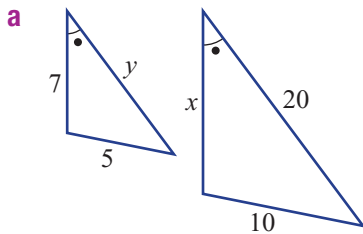

Hint: Scale factor = $\frac{\text{larger}}{\text{smaller}}$
Make sure you choose a matching pair of sides.

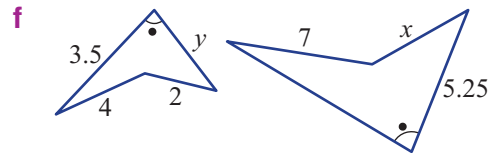
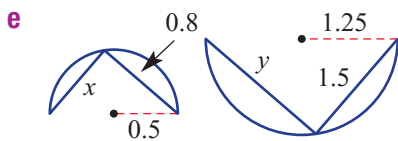
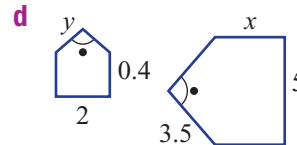
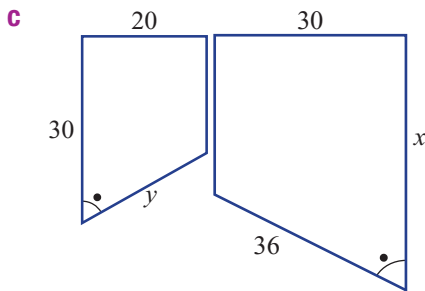

Example 14 Enlarging figures

Copy the given diagram using plenty of space, and use the given centre of enlargement (O) and these scale factors to enlarge $\triangle ABC$.

- Scale factor $\frac{1}{2}$
- Scale factor 3

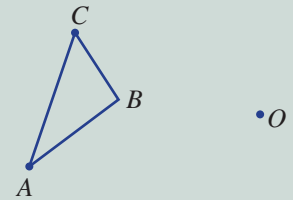

Solution

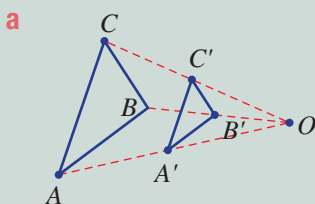

Explanation

Connect dashed lines between O and the vertices A , B and C .

Since the scale factor is $\frac{1}{2}$, place A' so that OA' is half of OA .

Repeat for B' and C' . Join vertices A' , B' and C' .

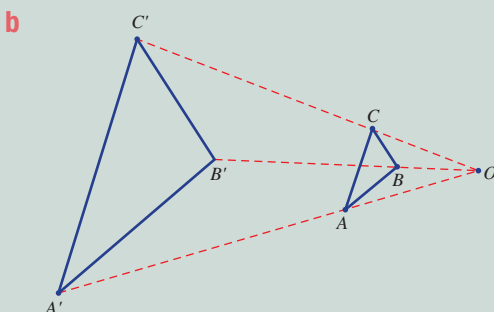

Draw dashed lines from O through A , B and C . Place A' so that OA' is 3 times OA . Repeat for B' and C' and form $\triangle A'B'C'$.

Now you try

Copy the given diagram using plenty of space, and use the given centre of enlargement (O) and these scale factors to enlarge $\triangle ABC$.

- a** Scale factor 2
b Scale factor $\frac{1}{2}$

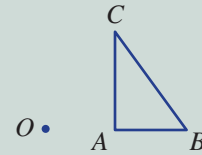

6 Copy the given diagram, leaving plenty of space around it. Use the given centre of enlargement (O) and given scale factors to enlarge $\triangle ABC$.

- a** Scale factor $\frac{1}{3}$
b Scale factor 2

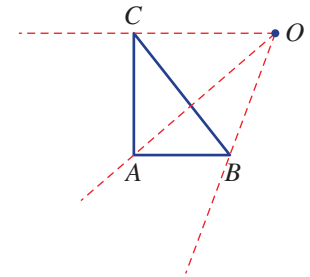

7 This diagram includes a square with centre O and vertices $ABCD$.

- a** Copy the diagram, leaving plenty of space around it.
b Enlarge square $ABCD$ by these scale factors and draw the image. Use O as the centre of enlargement.
i $\frac{1}{2}$ **ii** 1.5

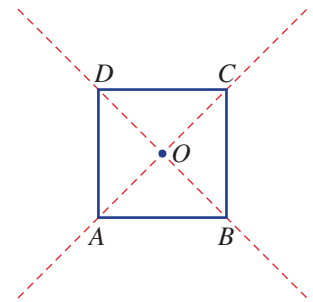
**Problem-solving and reasoning**

8, 9

10, 11

- 8** A square is enlarged by a scale factor of 4.
a Are the internal angles the same for both the original and the image?
b If the side length of the original square was 2 cm, what would be the side length of the image square?
c If the side length of the image square was 100 cm, what would be the side length of the original square?

Original

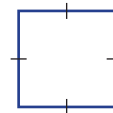

Image

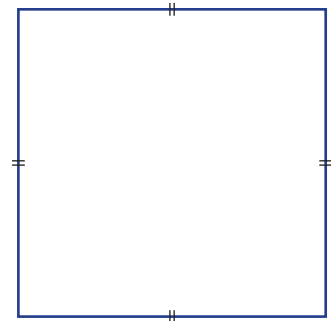

- 9** A photo of a sunflower is enlarged by a scale factor of 2. If the larger flower has a diameter of 7.4 cm, what is the diameter of the smaller flower?



8F

10 These diagrams show a shape and its image after enlargement. For each part, find:

- the scale factor
- the coordinates (x, y) of the centre of enlargement

a

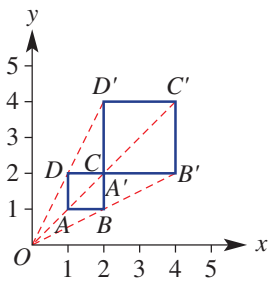

b

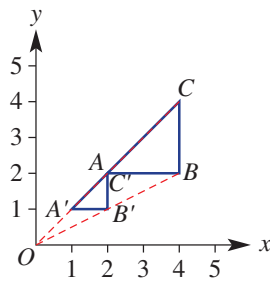

c

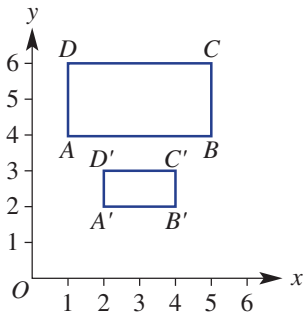

d

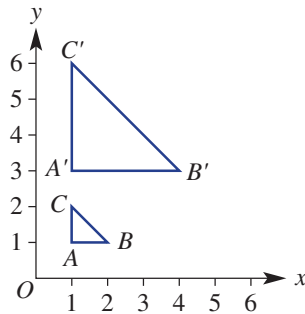

Hint: For parts c and d, first draw dashed red lines connecting A with A' etc.



11 Explain why:

- any two squares are similar
- any two equilateral triangles are similar
- any two rectangles are not necessarily similar
- any two isosceles triangles are not necessarily similar



Actual lengths from drawings and maps

—

12, 13

12 The container of this truck is 12.7 m long.

- Measure the length of the container on the truck in the drawing.
- Measure the height of the container on the truck in the drawing.
- Estimate the actual height of the container on the truck.

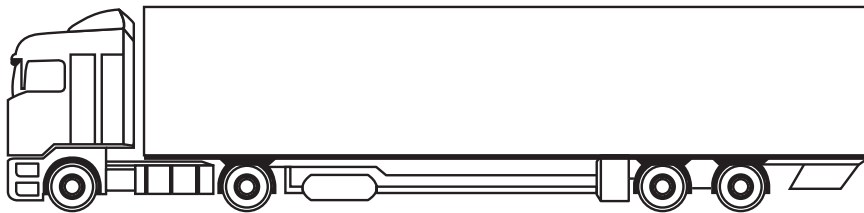

13 A map has a scale ratio of 1 : 50 000.

- What length on the ground is represented by 2 cm on the map?
- What length on the map is represented by 12 km on the ground?



8G Similar triangles

Learning intentions

- To understand the four tests for similarity of triangles
- To be able to recognise a pair of similar triangles using one of the four tests
- To be able to calculate and use the scale factor to find an unknown length

Key vocabulary: similar, scale factor, ratio, corresponding sides, corresponding angles, hypotenuse

As with congruent triangles, there are mathematical tests that can be used to see if two triangles are similar. Once we know that two triangles are similar, we can work out any missing angles and lengths.

Lesson starter: Why are AA and AAA the same test for triangles?

If all three angles are the same inside two triangles then we know that the triangles are similar. Here are a pair of triangles.

- Do you think they are similar?
- What is the missing angle in each triangle?
- Can you explain why the AA test is the same as AAA?

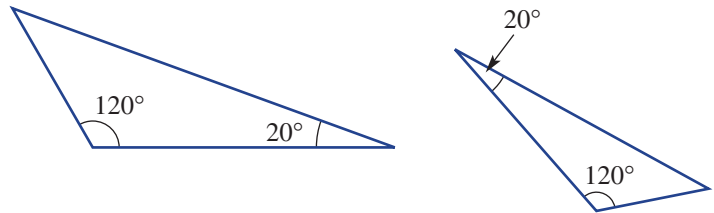

Key ideas

- Two triangles are similar if:
 - corresponding angles are equal
 - corresponding sides are in proportion (the same ratio).
- The similarity statement for two similar triangles $\triangle ABC$ and $\triangle DEF$ is:
 - $\triangle ABC \parallel\parallel \triangle DEF$ or
 - $\triangle ABC \sim \triangle DEF$
- Tests for similar triangles (not to be confused with the congruence tests for triangles):

- Side, Side, Side (SSS):
All three pairs of corresponding sides are in the same ratio.

$$\frac{12}{6} = \frac{8}{4} = \frac{14}{7}$$

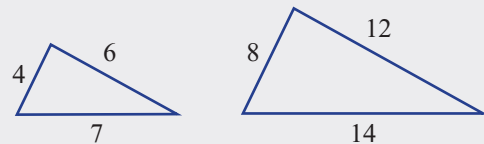

- Side, Angle, Side (SAS):
Two pairs of corresponding sides are in the same ratio and the included angles are equal.

$$\frac{22}{11} = \frac{10}{5}$$

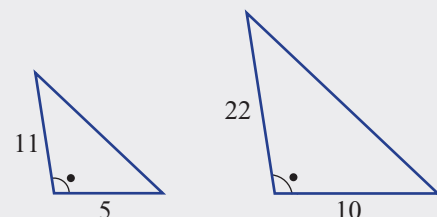

- Angle, Angle, Angle (AAA or AA):
All three corresponding angles are equal (If there are two equal pairs then the third pair must be equal.)

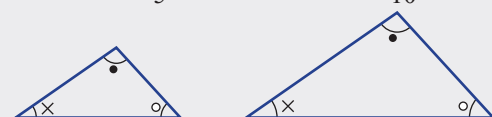

- Right angle, Hypotenuse, Side (RHS):
The hypotenuses of right-angled triangles and another corresponding pair of sides are in the same ratio.

$$\frac{15}{5} = \frac{6}{2}$$

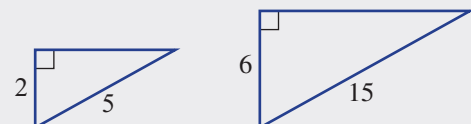

Exercise 8G

Understanding

1, 2

2

1 Copy and complete the following sentences.

- The abbreviated tests for similar triangles are SSS, ____, ____, and ____.
- Similar figures have the same _____ but are not necessarily the same _____.
- $\triangle ABC$ is a _____ (*line, triangle or quadrilateral*).
- If $\triangle ABC \parallel \triangle DEF$, then $\triangle ABC$ is _____ to $\triangle DEF$.

2 These two triangles are similar.

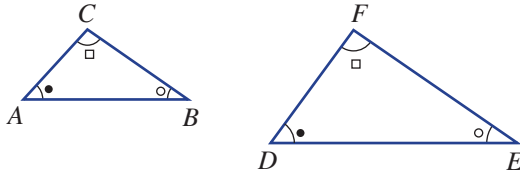

- Which vertex on $\triangle DEF$ corresponds to (matches) vertex B on $\triangle ABC$?
- Which vertex on $\triangle ABC$ corresponds to (matches) vertex F on $\triangle DEF$?
- Which side on $\triangle DEF$ corresponds to (matches) side AC on $\triangle ABC$?
- Which side on $\triangle ABC$ corresponds to (matches) side EF on $\triangle DEF$?
- Which angle on $\triangle ABC$ corresponds to (matches) $\angle D$ on $\triangle DEF$?
- Which angle on $\triangle DEF$ corresponds to (matches) $\angle B$ on $\triangle ABC$?

Fluency

3, 4(½), 5, 6

3–4(½), 6, 7



Example 15 Choosing a similarity test for triangles

Choose the similarity test that proves that these pairs of triangles are similar.

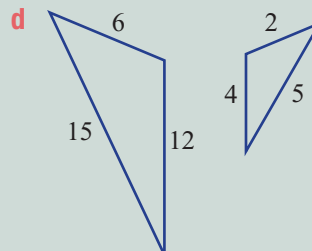
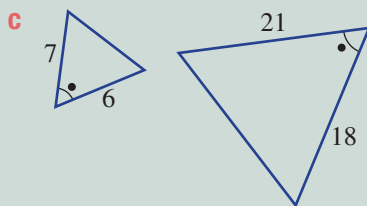
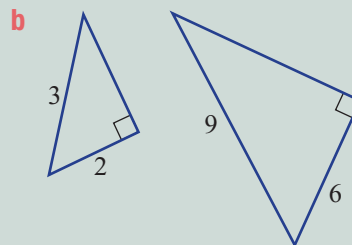
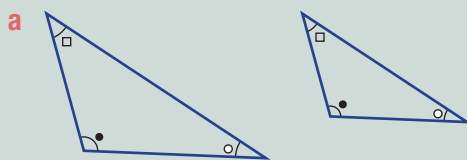

Solution

- AAA
- RHS

Explanation

Three pairs of angles are equal.

Both are right-angled triangles and the hypotenuses and another pair of sides are in the same ratio $\left(\frac{9}{3} = \frac{6}{2}\right)$.

c SAS

Two pairs of corresponding sides are in the same ratio $\left(\frac{21}{7} = \frac{18}{6}\right)$ and the included angles are equal.

d SSS

Three pairs of corresponding sides are in the same ratio $\left(\frac{15}{5} = \frac{12}{4} = \frac{6}{2}\right)$.

Now you try

Choose the similarity test that proves that these pairs of triangles are similar.

a

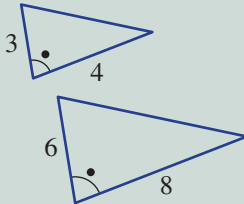

b

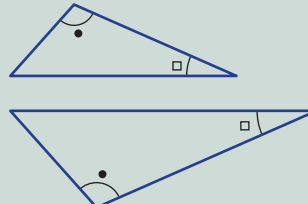

c

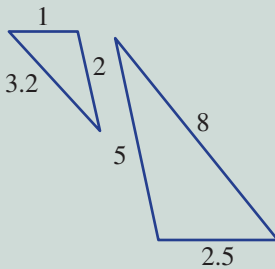

d

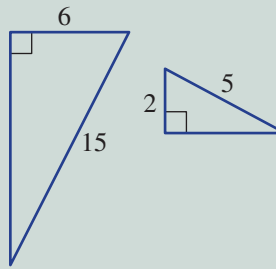

3 Choose the similarity test which proves that these pairs of triangles are similar.

a

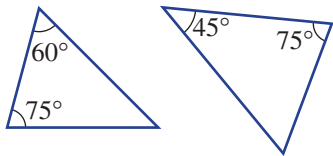

b

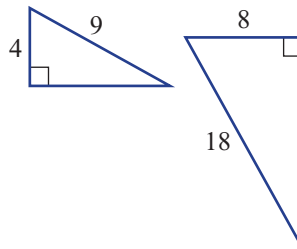

Hint: Choose from SSS, SAS, AAA or RHS.



c

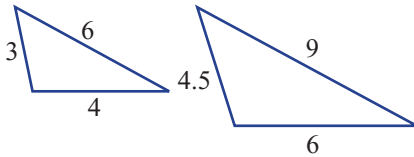

d

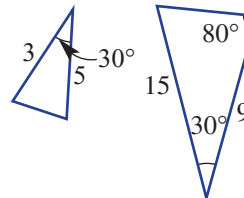

e

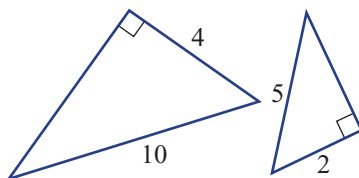

f

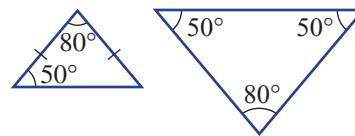

g

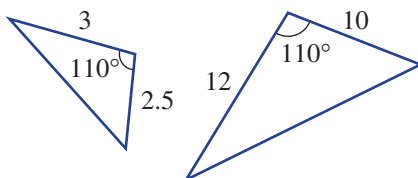

h

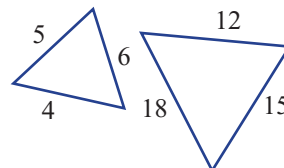

8G

4 Write similarity statements for these pairs of similar triangles. Write letters in matching order.

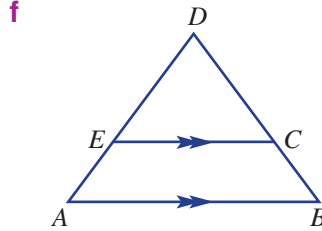
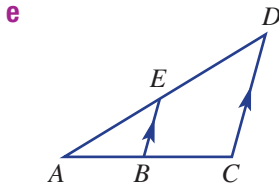
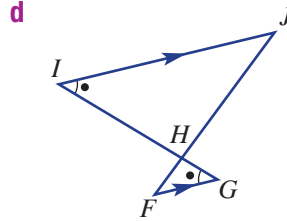
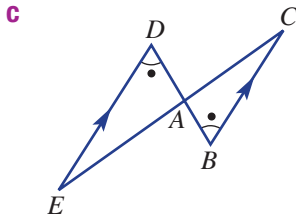
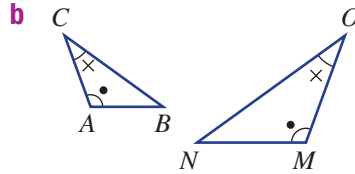
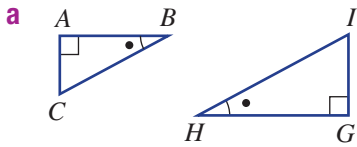

Hint: Here is an example of a similarity statement:
 $\triangle ABC \sim \triangle DEF$



Hint: For parts **e** and **f**, use angles in parallel lines.



5 What is the scale factor of this pair of similar triangles that enlarges $\triangle ABC$ to $\triangle DEF$?

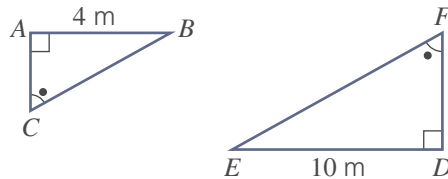

Example 16 Finding a missing length using similarity

For this pair of triangles:

- give a reason (SSS, SAS, AAA or RHS) why the two triangles are similar
- find the scale factor
- find the value of x

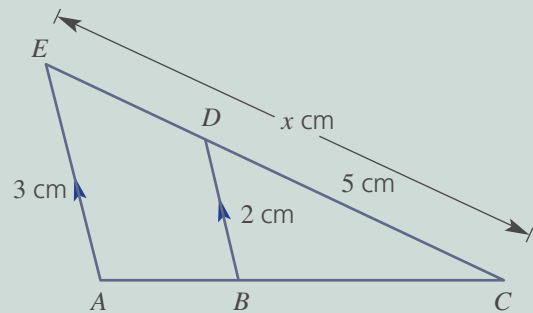

Solution

- AAA or just AA.
- Scale factor = $\frac{3}{2} = 1.5$.
- $x = 5 \times 1.5$
 $= 7.5$

Explanation

$\angle EAC = \angle DBC$ since AE is parallel to BD and $\angle C$ is common to both triangles. (Also $\angle AEC = \angle BDC$ since AE is parallel to BD).

$$\frac{AE}{BD} = \frac{3}{2}$$

Multiply CD by the scale factor to find the length of the corresponding length CE .

Now you try

For this pair of triangles:

- a give a reason (SSS, SAS, AAA or RHS) why the two triangles are similar
- b find the scale factor
- c find the value of x

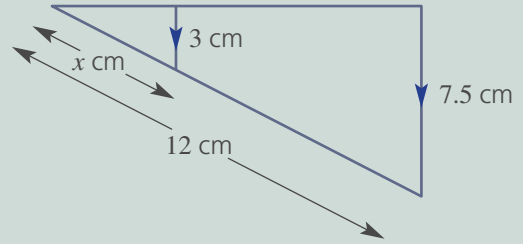

- 6 For this pair of triangles:
 - a give a reason (SSS, SAS, AAA or RHS) why the two triangles are similar
 - b find the scale factor
 - c find the value of x

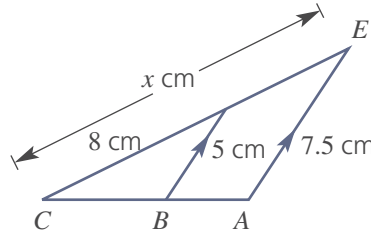

Hint: To use SSS, SAS or RHS, you need more than one pair of matching sides.



- 7 For this pair of triangles:
 - a give a reason (SSS, SAS, AAA or RHS) why the two triangles are similar
 - b find the scale factor
 - c find the value of x

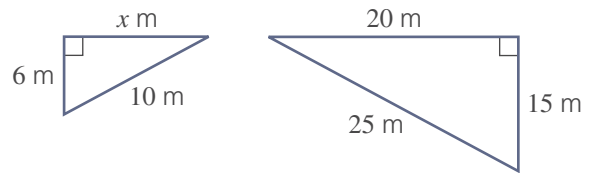

Problem-solving and reasoning

8, 9

8-11

- 8 Two people create a shadow in the Sun, as shown. What is the height of the taller person?

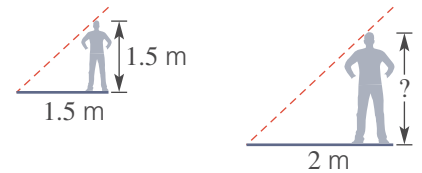

- 9 Name the triangle that is not similar to the other two in each group of three triangles.

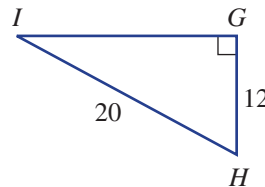
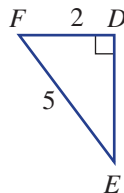
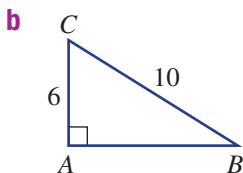
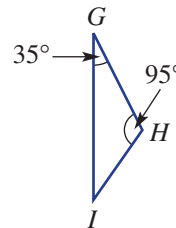
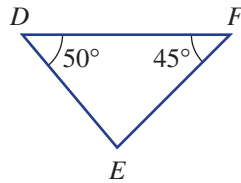
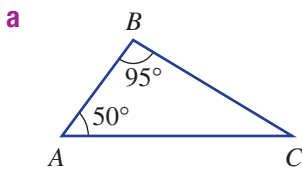

Hint: Name a triangle like this: $\triangle ABC$ or $\triangle STU$.



8G

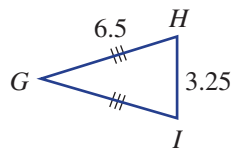
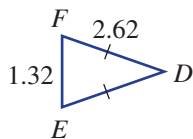
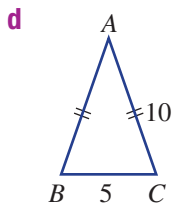
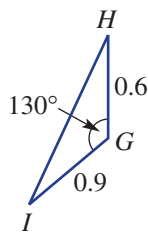
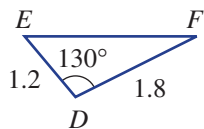
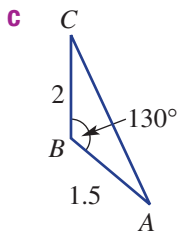

10 For each pair of similar triangles:

- i give a reason (SSS, SAS, AAA or RHS) why the two triangles are similar
- ii find the value of x

Hint: Consider angle properties in parallel lines.

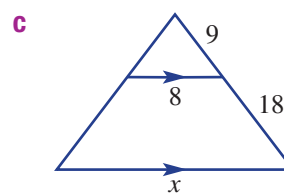
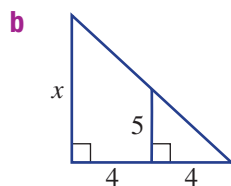
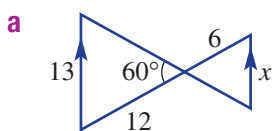

11 Give reasons why these two triangles are similar.

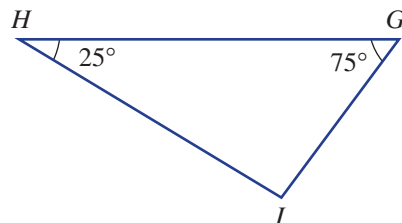
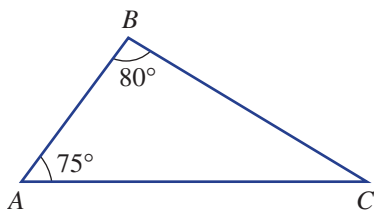

Area ratio

12 Consider these three similar triangles (not drawn to scale).

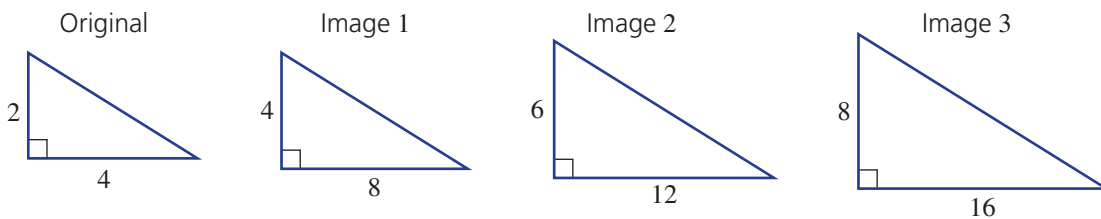

a Complete this table, comparing each image to the original.

Triangle	Original	Image 1	Image 2	Image 3
Length scale factor	1	2		
Area	4	16		
Area scale factor	1			

- b What do you notice about the area scale factor compared to the length scale factor?
- c What would be the area scale factor if the length scale factor is:
 - i 10?
 - ii 20?
 - iii 100?

8H Applying similar triangles

Learning intentions

- To be able to identify a pair of similar triangles in a given context
- To be able to give a reason why two triangles are similar
- To be able to calculate and use the scale factor to find an unknown length in a real situation

Key vocabulary: similar figures, scale factor

Similar triangles can be used in many mathematical and practical problems. If two triangles are proved to be similar then the properties of similar triangles can be used to find unknown lengths or angles. The approximate height of a tall object, or the width of a projected image, can be found using similar triangles.



→ Lesson starter: How high is it?

A 1 m vertical stick gives a shadow 80 cm long. At the same time, a tall tree has a shadow 24 m long.

- How can AAA be used to explain the two similar triangles?
- What is the scale factor?
- What is the height of the tree?

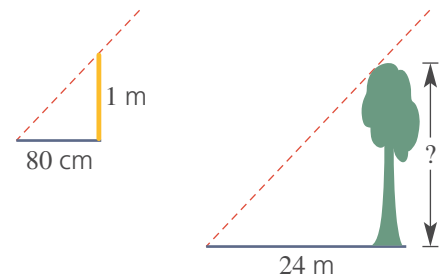

Key ideas

- To apply similarity in practical problems involving triangles:
 - Prove that two triangles are similar by stating one of the tests: SSS, SAS, AAA or RHS.
 - Find a scale factor.
 - Find the value of any unknowns.

Exercise 8H

Understanding

1–3

3

- Here are two triangles.
 - How many pairs of equal matching angles are given?
 - Which test (SSS, SAS, AAA or RHS) explains why they are similar?
 - What is the scale factor if the smaller triangle is enlarged to the size of the larger triangle?
 - Find the value of x .

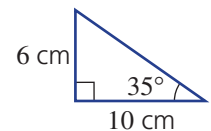
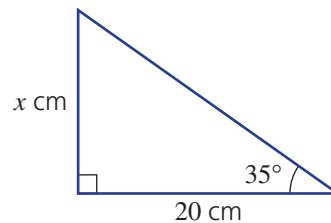

- In this diagram, name the angle that is common to both $\triangle ACE$ and $\triangle BCD$.

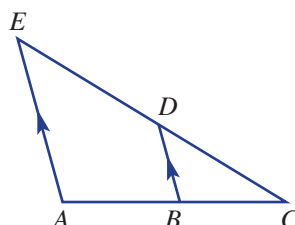

Hint: You can name the angle like this: $\angle S$.



8H

- 3 In this diagram:
- name the pair of vertically opposite angles
 - name the two pairs of equal alternate angles

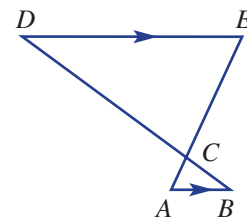

Fluency

4-7

5-8

- 4 Two similar triangles are created by cables supporting a yacht's mast.
- Find a scale factor for the two triangles.
 - Find the height of the mast.

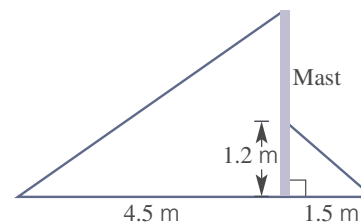

Example 17 Applying similarity

Chris' shadow is 1.2 m long while a 1 m vertical stick has a shadow 0.8 m long.

- Give a reason why the two triangles are similar.
- Determine Chris' height.

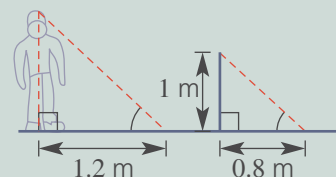

Solution

- a All angles are the same (AAA).

- b $\text{Scale factor} = \frac{1.2}{0.8} = 1.5$
 $\therefore \text{Chris' height} = 1 \times 1.5$
 $= 1.5 \text{ m}$

Explanation

The Sun's rays will pass over Chris and the stick and hit the ground at approximately the same angle.

First find the scale factor.

Multiply the height of the stick by the scale factor to find Chris' height.

Now you try

Two ladders lean against a vertical wall at the same angle as shown. The distances that the base of the ladders are from the wall are 3 m and 6 m.

- Give a reason why the two triangles are similar.
- Find how high the longer ladder reaches up the wall if the shorter ladder reaches up 5 m.

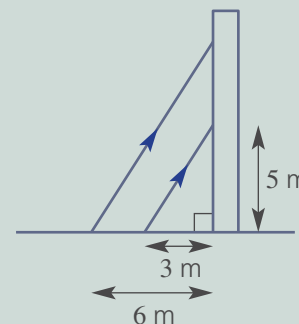

- 5 A tree's shadow is 20 m long while a 2 m vertical stick has a shadow 1 m long.
- Give a reason why the two triangles contained within the objects and their shadows are similar.
 - Find the height of the tree.

Hint: Construct a diagram as in Example 17.



- 6 John stands 6 m from a lamp post and casts a 2 m shadow. The shadow from the pole and from John end at the same place. If John is 1.5 m tall, what is the height of the lamp post?
- 7 Two cables support a steel pole at the same angle as shown. The two cables are 4 m and 10 m in length and the shorter cable reaches 3 m up the pole.
- Give a reason why the two triangles are similar.
 - Find the height of the pole.

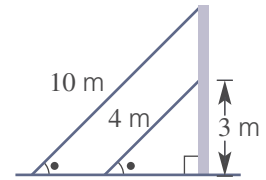

- 8 Ali is at the beach and decides to estimate how far an exposed rock is from the seashore. He places four pegs in the sand as shown, and measures the distance between them.
- Why do you think Ali has placed the four pegs in the way that is shown in the diagram?
 - Are the two triangles similar? Which test (SSS, SAS, AAA or RHS) could be used?
 - How far is the rock from the beach?

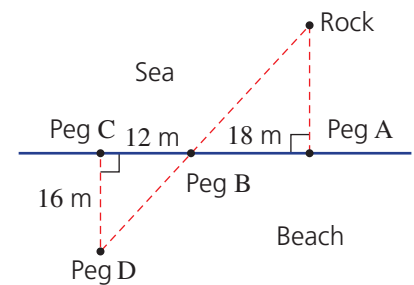

Problem-solving and reasoning

9, 10

9, 11

- 9 A deep chasm has a large rock (R) sitting on its side, as shown. Find the width of the chasm.

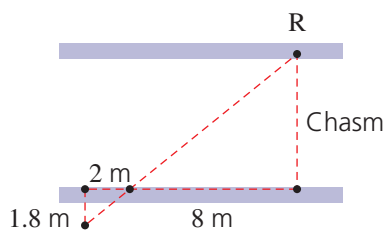

Hint: Don't forget to find the scale factor.



- 10 Joanne wishes to determine the width of the river shown without crossing it. She places four pegs as shown. Calculate the river's width.

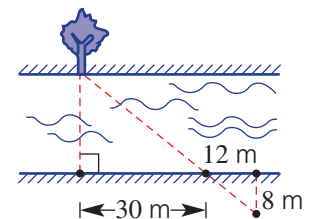

8H

- 11 A person 1.8 m tall stands in front of a light that sits on the floor. The person casts a shadow on the wall behind them.

a Find how tall the shadow will be if the distance between the wall and the light is:

- i 4 m
- ii 10 m
- iii 3 m

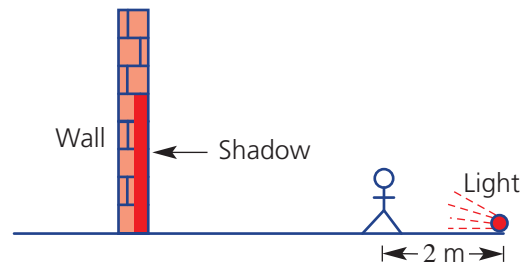

- b How tall will the shadow be if the distance between the wall and the person is:

- i 4 m?
- ii 5 m?

c Find the distance from the wall to the person if the shadow is:

- i 5.4 m
- ii 7.2 m



Visual challenge

12, 13

- 12 Find the length AB in this diagram if the two triangles are similar.

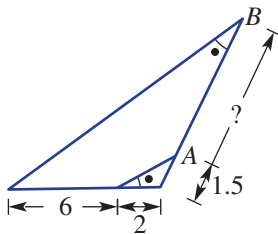

Hint: Remember to line up corresponding sides for the scale factor.



- 13 In this diagram, AC is perpendicular (at right angles) to BD and $\triangle ABD$ is right-angled.

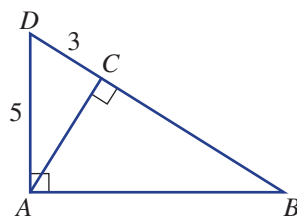

- a How many similar triangles are there?
- b Find the lengths:
- i BD
 - ii AC
 - iii AB



Maths@Work: Animator

Animators are creative people who use their skills to hand-draw, model or computer-generate images to create animated effects.

While animators are artistic, many other skills are necessary to excel in this field. Animators must be patient, have an eye for detail, and be able to work in groups as well as independently. They need excellent communication skills and IT skills.

Geometry and linear programming are important in this field as they allow the animator to illustrate how an image can be rotated and shifted. Similarity and congruency of objects are used to ensure consistency between scenes.

Animating is not just restricted to the movies. Computer and console computer games, television series, advertising and even corporate training organisations often directly employ or out-source animators.



1 Being able to accurately copy drawings by hand is a skill used in some forms of animation. Use your knowledge of angles and proportion to carefully copy these logos into your workbook.

a



b



c

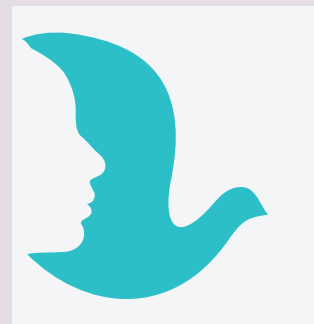

2 Using graph paper, enlarge each of the following logos by a factor of two.

a

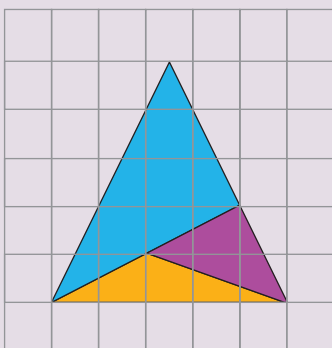

b

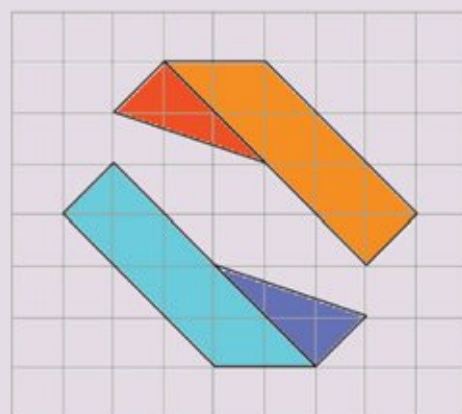

- 3 How many pairs of congruent triangles are in the symmetrical logo below?
Can you see any pairs of similar triangles?

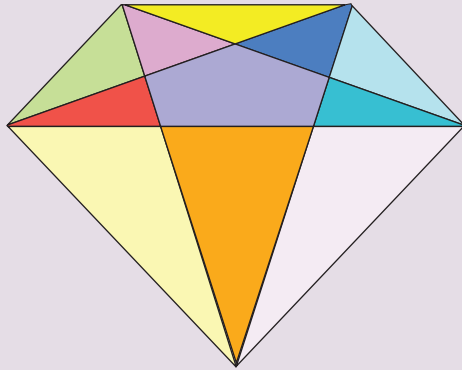

- 4 Compare each of the following figures and state how each has been rotated relative to the preceding one. You will need to use a protractor.

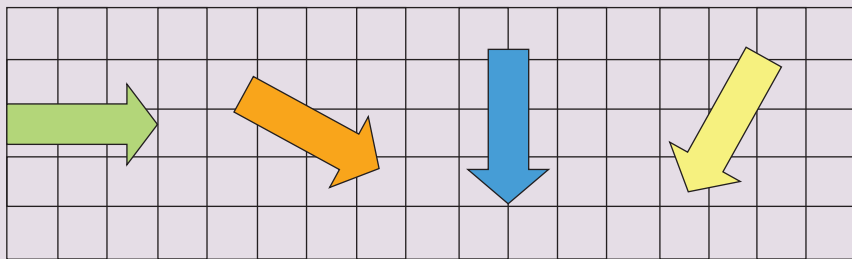

Using technology

- 5 Animators enjoy creating original designs. Use computer drawing software, such as Geometer's Sketchpad, to design a geometrical logo from the initials of your name. Some ideas for 'D and W' logos are shown below, but your design can be original if you wish.



Ocean Ironman

The organisers of an ocean ironman event want to estimate the distance from the beach to a floating buoy in the sea. Flags are placed on the beach by the organisers in an effort to create similar triangles as shown.

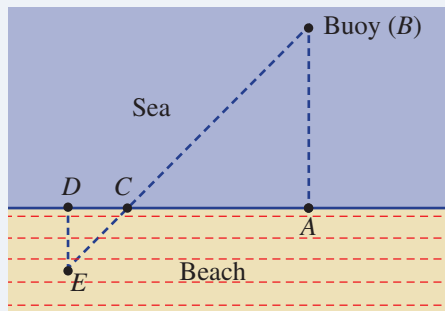

The flag positions are at A , C , D and E and the line segments AB and DE are assumed to be at right angles with AD at the beach.

Present a report for the following tasks and ensure that you show clear mathematical workings and explanations where appropriate.

Preliminary task

Once the flags are in position one of the organisers measures the following;

- $AC = 200$ metres
 - $CD = 5$ metres
 - $DE = 4$ metres
- a Find the scale factor between the two similar triangles.
 - b Hence, estimate the distance from the beach to the buoy (distance AB).

Modelling task

The problem is to determine the distance between the beach and the buoy using similar triangles.

- a Write down all the relevant information that will help solve this problem, and illustrate using diagrams.
- b Explain why the positions of the flags placed by the organisers produce a pair of similar triangles. (That is, triangle DCE is similar to triangle ACB).

- c Two more attempts at positioning flags and measuring distances are undertaken by the organisers.

Jimmy's placement:

- $AC = 360$ metres
- $CD = 8$ metres
- $DE = 3$ metres.

Olivia's placement:

- $AC = 90$ metres
- $CD = 5$ metres
- $DE = 8$ metres.

- i Use Jimmy's model to estimate the distance between the beach and the buoy.
- ii Use Olivia's model to estimate the distance between the beach and the buoy.

- d Another organiser attempts to place the flags such that:
- $AC = 100$ metres
 - $CD = 50$ centimetres
 - $DE = 1.2$ metres.

Do you think that arranging the flags in this way is a good idea? Explain why.

- e If the actual distance from the beach to the buoy is 200 metres, determine an arrangement for the flags that would deliver the correct distance. Illustrate with a diagram including the measurements.

- f Summarise your results in a table.

	AC	CD	DE	AB
PERSON 1	200	5	4	
JIMMY				
OLIVIA				
PERSON 4				

Comment on any findings and recommendations.

Extension questions

- a Another way to arrange the flags is to use the model shown here. Using this model, identify the pair of similar triangles and explain why they are similar.
- b Using the following measurements, estimate the distance from the beach to the buoy.
- $AC = 100$ metres
 - $AE = 60$ metres
 - $DE = 140$ metres
- c Compare the two models studied in this task using the different diagrams. Do you have a preferred model? Explain why.

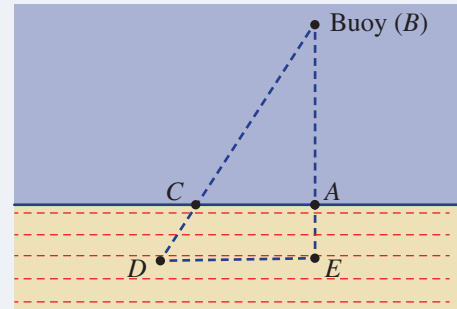

- Use 12 matchsticks to make 6 equilateral triangles.
- Find the value of a in the diagram.

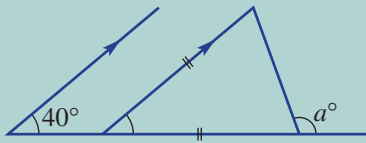

- How many acute angles are there in this diagram?

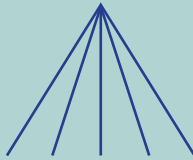

- A circle is divided using chords (one chord is shown here, giving two regions). What is the maximum number of regions that can be formed if the circle is divided with 4 chords?

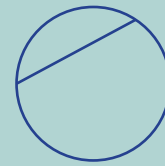

- Explore (using dynamic geometry) where the points A , B and C should be on the sides of $\triangle DEF$ so that the perimeter of $\triangle ABC$ is a minimum.

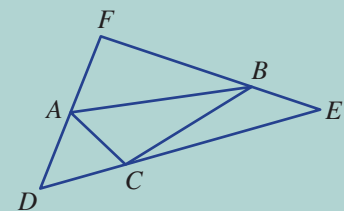

- The Sierpinski triangle shown is a mathematically generated pattern. It is created by repeatedly enlarging triangles by a factor of $\frac{1}{2}$. The steps are:

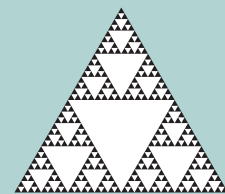

- Start with an equilateral triangle, as in figure 1.
- Enlarge the triangle by a factor of $\frac{1}{2}$.
- Arrange three copies of the image, as in figure 2.
- Continue repeating steps 2 and 3 with each triangle.

- Make a large copy of figures 1 to 3 and then draw the next two figures in the pattern.
- If the original triangle (figure 1) had side length l , what is the side length of the smallest triangle in:

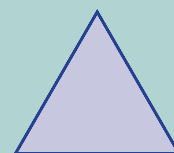

Figure 1

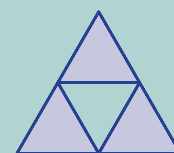

Figure 2

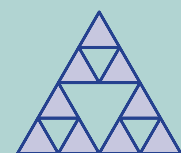
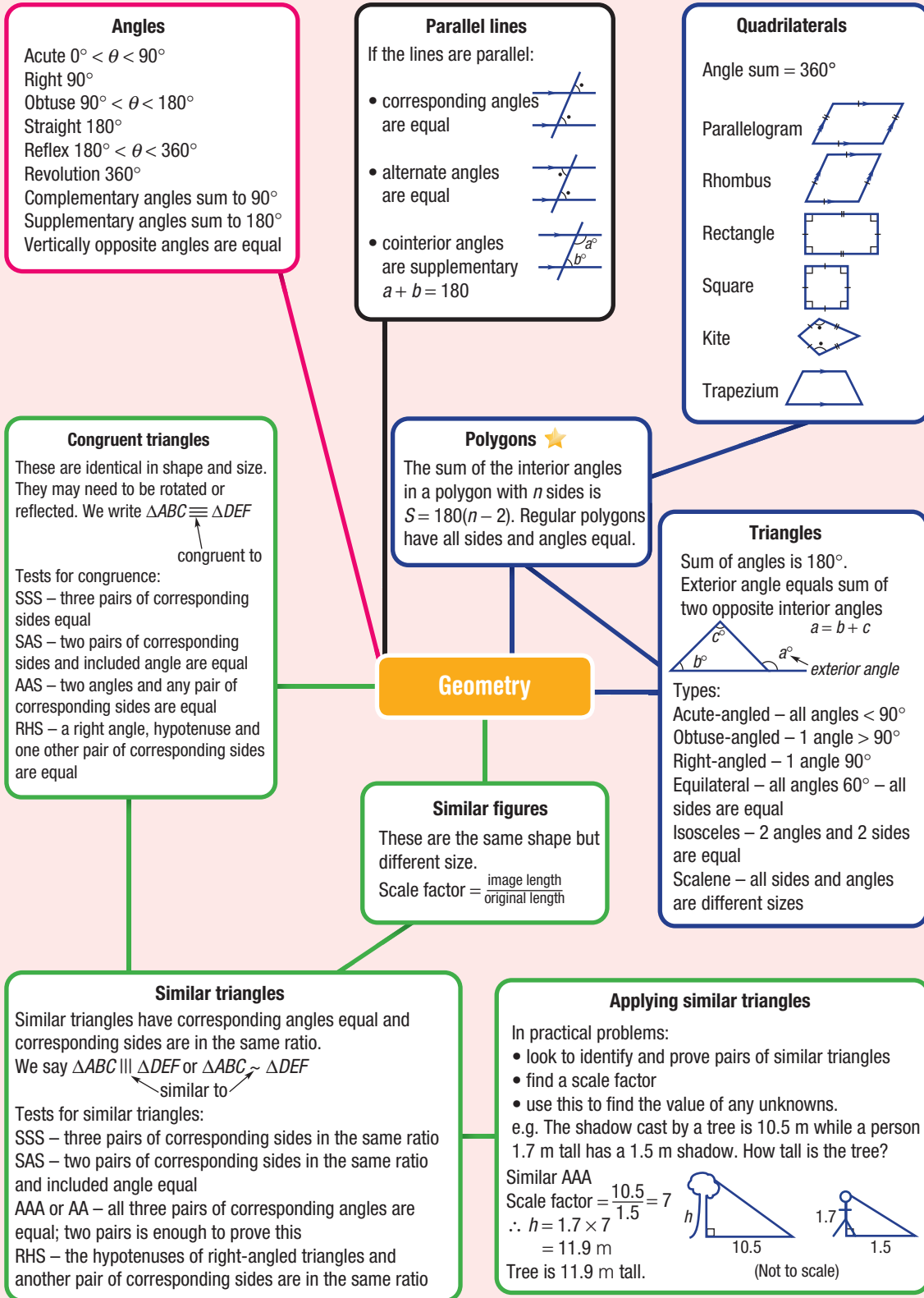

Figure 3

- figure 2?
 - figure 3?
 - figure 8 (assuming figure 8 is the 8th diagram in the pattern)?
- What fraction of the area is shaded in:
 - figure 2?
 - figure 3?
 - figure 6 (assuming figure 6 is the 6th diagram in the pattern)?
 - The Sierpinski triangle is one where the process of enlargement and copying is continued forever. What is the shaded area of a Sierpinski triangle?



Chapter checklist

A version of this checklist that you can print out and complete can be downloaded from your Interactive Textbook.

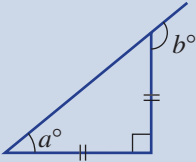
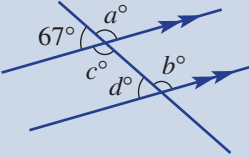
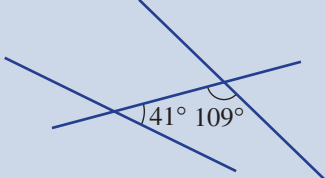
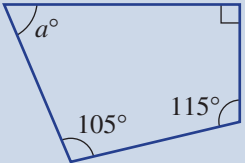
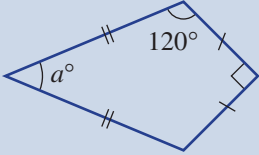
	✓
<p>8A 1 I can find supplementary and complementary angles. e.g. State the supplementary and complementary angle to 25°.</p>	
<p>8A 2 I can name triangles and find the size of unknown angles. e.g. Name the type of triangle in this diagram and find the values of the pronumerals.</p> 	
<p>8B 3 I can find unknown angles in parallel lines. e.g. Find the values of the pronumerals in this diagram and give a reason.</p> 	
<p>8B 4 I can explain why two lines are parallel. e.g. Decide, with reasons, whether the given pair of lines are parallel.</p> 	
<p>8C 5 I can identify properties of various quadrilaterals. e.g. Name the special quadrilaterals which have diagonals which intersect at 90°.</p>	
<p>8C 6 I can find an unknown angle in a quadrilateral. e.g. Find the value of a in this quadrilateral.</p> 	
<p>8C 7 I can find an unknown angle in a special quadrilateral. e.g. Find the value of a in this kite.</p> 	

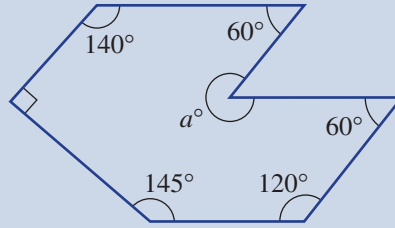

8D

8 I can find an angle sum of a polygon and an unknown angle in a polygon.e.g. Find the value of a in this heptagon after finding the angle sum.

8D

9 I can find the internal angle in a regular polygon.

e.g. Find the size of an internal angle inside a regular octagon.

8E

10 I can choose a test and write a congruence statement for a pair of congruent triangles.

e.g. Write a congruence statement and choose a test to prove congruence for this pair of triangles.

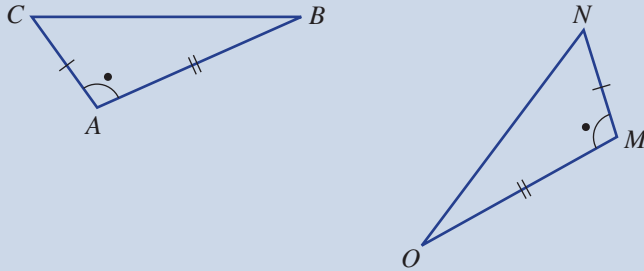

8E

11 I can find missing side lengths and angles in congruent triangles.

e.g. Find the value of the pronumerals given the following pair of congruent triangles.

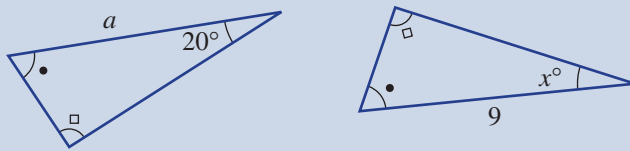

8F

12 I can find the scale factor for a pair of similar figures and find the length of unknown sides.

e.g. Find the scale factor for these similar figures then find the value of the pronumerals.

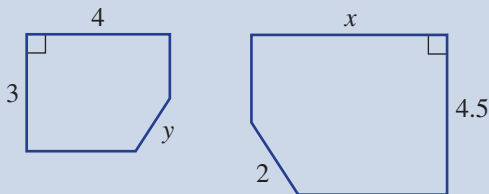

8F

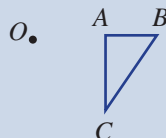
13 I can draw a similar figure using the enlargement transformation and a given scale factor.e.g. Copy the given diagram and enlarge the given shape using the centre of enlargement (O) and the scale factors of 3 and also $\frac{1}{2}$.



8G

- 14 I can recognise when two triangles are similar using one of the four tests.**
e.g. Give the reason why these triangles are similar.



8G

- 15 I can find a scale factor and use this to find an unknown length.**
e.g. If the given pair of triangles is known to be similar, find the value of x .

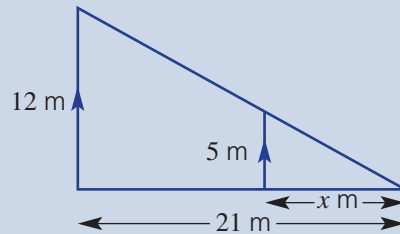

8H

- 16 I can identify similar triangles in a real context and use a scale factor to find an unknown length.**
e.g. A tree's shadow is 20 m long and a 4 m high vertical stick has a 5 m shadow at the same time of day.
- Use a diagram to form a pair of similar triangles and give a reason why they are similar.
 - Use the scale factor to find the height of the tree.

Short-answer questions

8A 1 Find the value of the pronumerals.

a

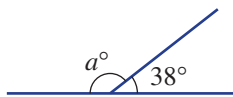

b

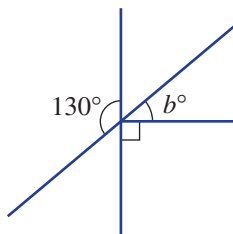

c

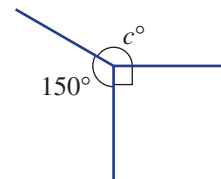

8A 2 Name the following triangles and find the value of the pronumerals.

a

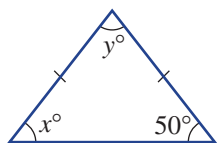

b

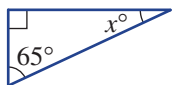

c

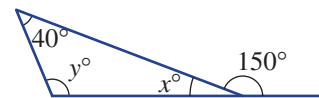

8B 3 Decide whether the following contain a pair of parallel lines. Give a reason.

a

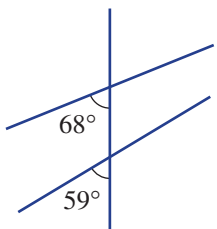

b

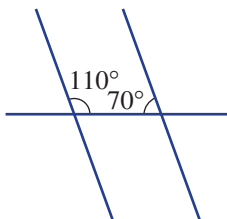

c

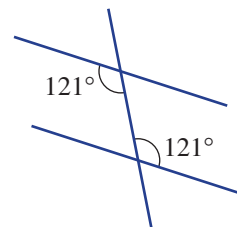

8B 4 State the values of the pronumerals.

a

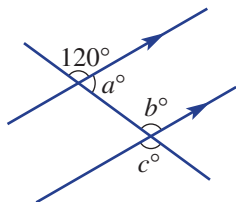

b

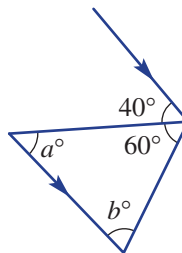

c

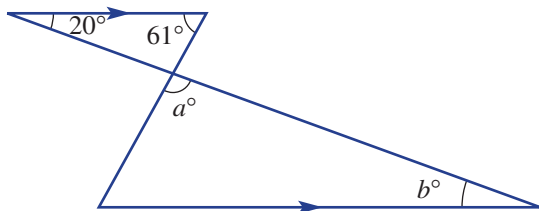

8C 5 Name the quadrilaterals that have:

- a equal length diagonals
- b diagonals intersecting at right angles
- c two pairs of equal length sides

8C 6 Find the value of each pronumeral in the following quadrilaterals.

a

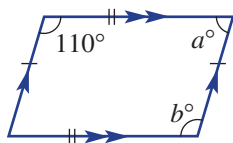

b

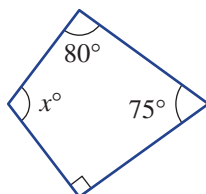

c

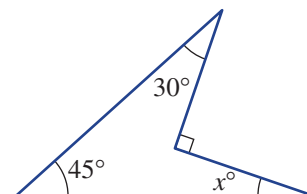

- 8D** **7** Find the value of the pronumeral in these polygons. Use $S = 180(n - 2)$ for the angle sum.

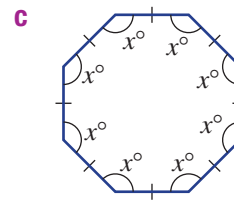
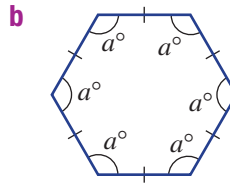
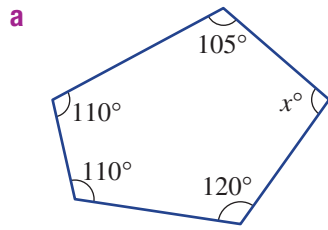

- 8E** **8** Determine whether each pair of triangles is congruent. If congruent, give the abbreviated reason (SSS, SAS, AAS or RHS) and state the value of any pronumerals.

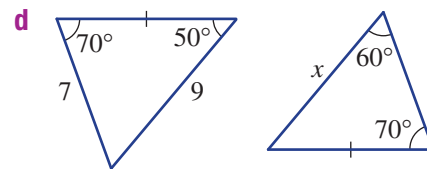
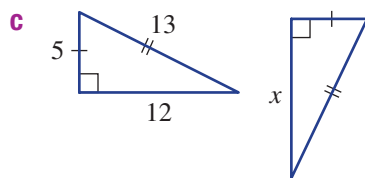
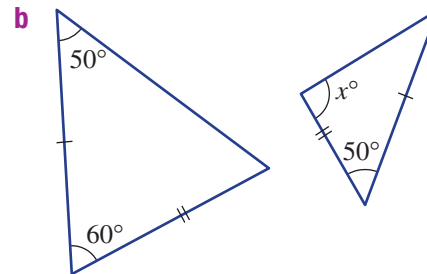
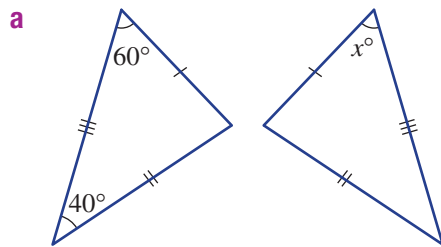

- 8F** **9** Copy the given diagram using plenty of space. Using the centre of enlargement (O) and a scale factor of 3, enlarge $\triangle ABC$.

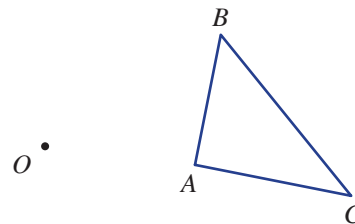

- 8G** **10** Determine whether the following pairs of triangles are similar, and state the similarity test (SSS, SAS, AAS or RHS) that proves this.

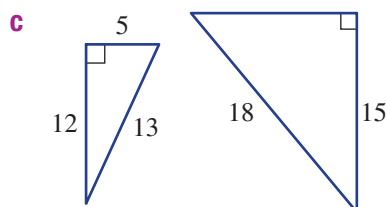
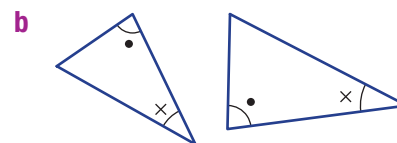
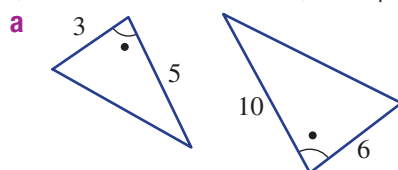

8G 11 For the following pairs of similar triangles, find the value of x .

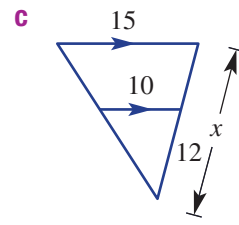
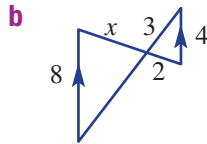
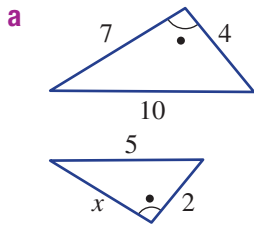

8H 12 A conveyor belt loading luggage onto a plane is 12 m long. A vertical support 1.6 m high is placed under the belt. It is 4 m along the conveyor belt, as shown in the diagram.



- a** Find the scale factor for the two similar triangles.
b Find the height (AE) of the luggage door above the ground.

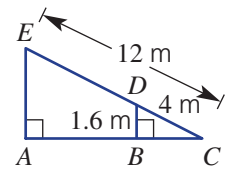

Multiple-choice questions

8A 1 The angle that is supplementary to an angle of 55° is:

- A** 35° **B** 55° **C** 95° **D** 125° **E** 305°

8B 2 What is the value of x if AB is parallel to CD ?

- A** 110 **B** 70 **C** 20
D 130 **E** 120

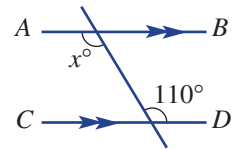

8A 3 If two angles in a triangle are 30° and 80° , then the third angle is:

- A** 110° **B** 70° **C** 90° **D** 80° **E** 30°

8B 4 The values of x and y in the diagram are:

- A** $x = 35, y = 85$
B $x = 45, y = 45$
C $x = 50, y = 60$
D $x = 55, y = 65$
E $x = 65, y = 55$

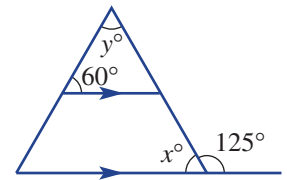

8D 5 Using $S = 180 \times (n - 2)$, the sum of the interior angles in a hexagon is:

- A** 1078° **B** 360° **C** 720° **D** 900° **E** 540°



8C 6 The quadrilateral with all sides equal, two pairs of opposite parallel sides and no right angles is:

- A** a kite **B** a trapezium **C** a parallelogram
D a rhombus **E** a square

8C 7 The value of a in the diagram is:

- A** 45
B 310
C 75
D 60
E 50

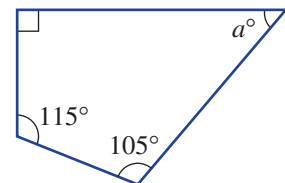

8E 8 The abbreviated reason for congruence in the two triangles shown is:

- A** AA **B** SAS **C** SSS
D AAS **E** RHS

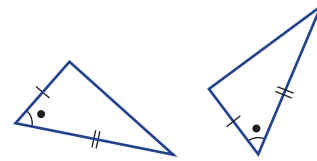

8F 9 The scale factor in the two similar figures shown that enlarges the original figure to its image is:

- A** $\frac{2}{3}$ **B** 2 **C** 1.2
D 1.5 **E** 0.5

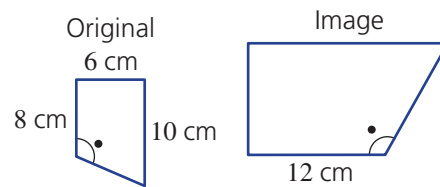

8G 10 The value of x in the diagram is:

- A** 6 **B** 9 **C** 10
D 8 **E** 7.5

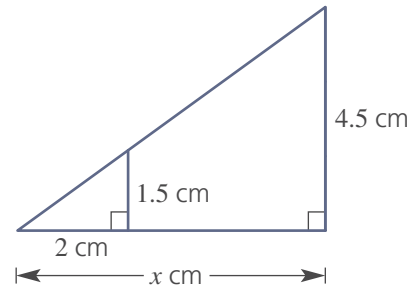

Extended-response questions

- 1 In this complicated diagram there are two triangles and one quadrilateral.
- Name the types of triangles.
 - Find the values of the pronumerals in alphabetical order. Give a reason at each step.

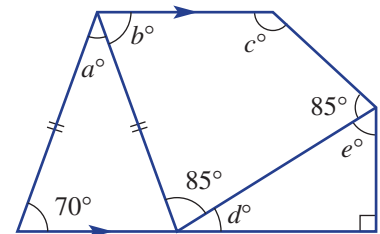

- 2 A buoy (E) is floating in the sea at some unknown distance from the beach, as shown. The points A , B , C and D are measured and marked out on the beach, as shown.



- Name the angle that is vertically opposite to $\angle ACB$.
- Explain, with reasons, why $\triangle ABC \cong \triangle EDC$.
- Find the distance from the buoy to the beach (ED) to one decimal place.

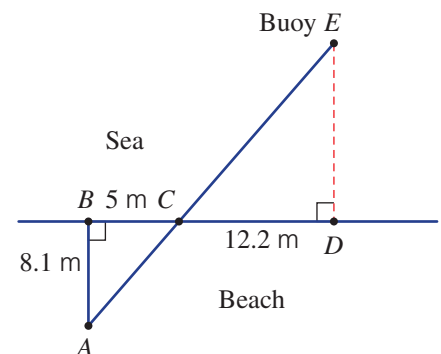



Chapter 9

Algebraic techniques

Essential mathematics: why skills with algebra are important

Algebra skills are essential when applying formulas in business, the professions and the trades, such as the air-conditioning, aviation, construction, electrical, electronic, manufacturing, mechanic, mechanical, metal working, plumbing, retail and welding trades.

- Apprenticeship training for the electrical trades involves using many formulas requiring algebraic techniques including fractions. Nurses use algebraic techniques including fractions to determine medical dosage amounts and intravenous fluid quantities.
- Financial mathematical analysis is a key to success for businesses. Algebraic skills are required to apply formulas that calculate the financial aspects of a business, including expenses, revenue, losses, profits, GST, wages, tax amounts, insurance and any loan repayments.
- Examples of small businesses that require financial analysis include hairdressers, bakers, cake makers, café or food truck owners, dog groomers, fashion designers, florists, food delivery services, personal fitness trainers and numerous technology start-ups.

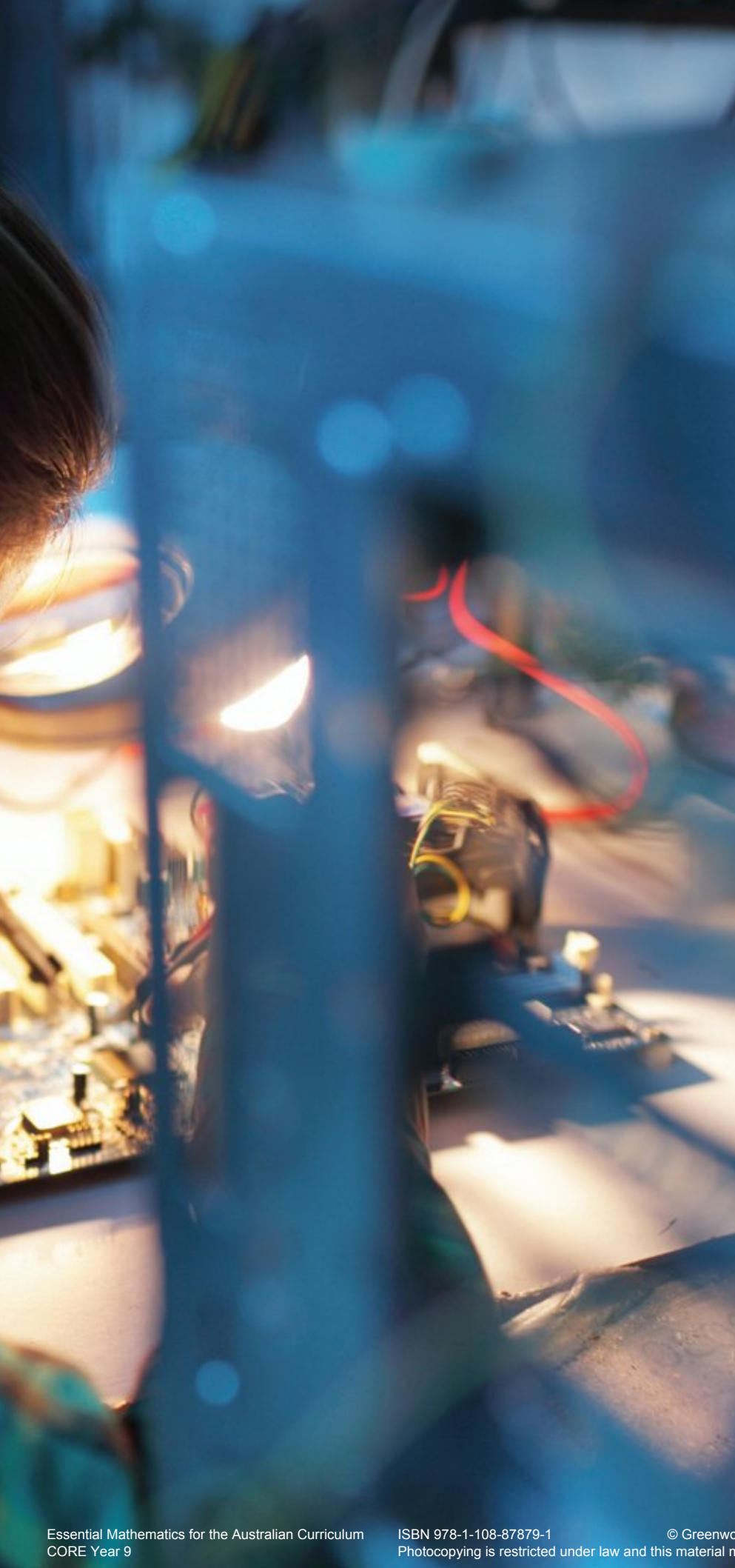

In this chapter

- 9A Reviewing algebra
(Consolidating)
- 9B Expanding binomial products
- 9C Expanding perfect squares
- 9D Forming a difference of perfect squares
- 9E Factorising algebraic expressions
- 9F Simplifying algebraic fractions: multiplication and division ★
- 9G Simplifying algebraic fractions: addition and subtraction ★

Australian Curriculum

NUMBER AND ALGEBRA

Patterns and algebra

Apply the distributive law to the expansion of algebraic expressions, including binomials, and collect like terms where appropriate (ACMNA213)

© Australian Curriculum, Assessment and Reporting Authority (ACARA)

Online resources

A host of additional online resources is included as part of your Interactive Textbook, including HOTmaths content, video demonstrations of all worked examples, auto-marked quizzes and much more.

- 1 Write down the coefficient of x in these expressions.
- a** $4x - 1$ **b** $3y + 6x$ **c** $3xy - 2x$ **d** $-4x^2 - 7x$
- 2 What is the constant term in these expressions?
- a** $5 - 2x$ **b** $-16a + 2$
c $5xy - 2x + 1$ **d** $101x - 6$
- 3 Evaluate the following if $a = 2$ and $b = -5$.
- a** ab **b** $-3b + 1$ **c** $4 - b + a$ **d** $5a^2b$
e $\sqrt{a^2}$ **f** $2b^2 - a$ **g** $5 - b^2$ **h** $a^2b - 2b^2$
- 4 Expand the following using $a(b + c) = ab + ac$.
- a** $2(x + 3)$ **b** $3(a - 5)$ **c** $4x(3 - 2y)$ **d** $-3(2b - 1)$
- 5 Write down the highest common factor of:
- a** 4 and 6 **b** 12 and 18 **c** $2x$ and $4x$
d $3xy$ and $9y$ **e** $10x$ and $15x^2$ **f** $3a^2b$ and $4ab^2$
- 6 Factorise by taking out the highest common factor.
- a** $2a + 6$ **b** $3x + 12y$ **c** $5x^2 - 15x$ **d** $4m - 6mn$
- 7 Add or subtract these fractions. You will need a common denominator for parts **c** and **d**.
- a** $\frac{3}{7} + \frac{2}{7}$ **b** $\frac{4}{9} - \frac{5}{9}$ **c** $\frac{1}{2} + \frac{2}{3}$ **d** $\frac{3}{8} - \frac{1}{2}$
- 8 Multiply or divide these fractions.
- a** $\frac{2}{3} \times \frac{4}{5}$ **b** $\frac{3}{4} \times \frac{2}{3}$ **c** $\frac{7}{14} \times \frac{2}{3}$ **d** $\frac{6}{11} \times \frac{22}{12}$
e $\frac{2}{3} \div \frac{1}{3}$ **f** $\frac{7}{8} \div \frac{14}{24}$ **g** $\frac{3}{2} \div \frac{4}{3}$ **h** $\frac{7}{9} \div \frac{4}{3}$
- 9 Expand and simplify.
- a** $3(x - 1) + 5$ **b** $4(1 - x) + 5x$ **c** $-2(5 + x) - x$
- 10 Write two expressions for the area of this rectangle, one with brackets and one without.

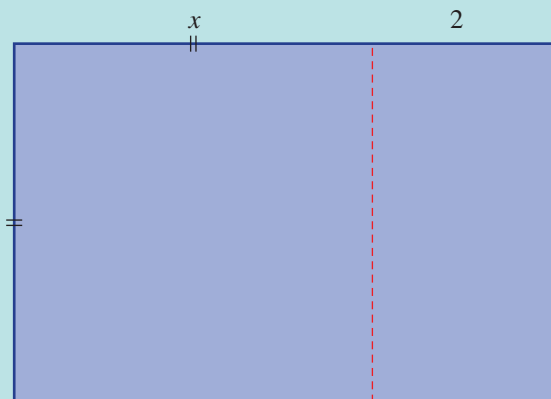

9A Reviewing algebra

CONSOLIDATING

Learning intentions

- To know the names of the parts of an algebraic expression
- To be able to form algebraic expressions from simple word phrases
- To know that only like terms can be combined under addition and subtraction
- To be able to simplify algebraic expressions using the four operations: +, −, × and ÷
- To be able to expand expressions involving brackets
- To be able to evaluate expressions by substituting given values

Key vocabulary: expression, pronumeral, variable, term, like terms, constant term, coefficient, distributive law, evaluate

A high level of skill in algebra is required to solve more complex mathematical problems. Skills include adding, subtracting, multiplying and dividing algebraic expressions, as well as expanding and factorising expressions.

In this section we will review some basic concepts in algebra.

→ Lesson starter: Vocab review

Consider the expression $3x^2 + 4xy - 2 - xy$.

- How many terms are given in the expression?
- What letters are used as pronumerals?
- What is the coefficient of x^2 ?
- What is the constant term?
- Are there any like terms?
- Can the expression be simplified? If so, how?
- What would be the value of the expression if $x = 2$ and $y = -1$?

Key ideas

- An **expression** is a combination of numbers and pronumerals connected by mathematical operations.
 - A **term** is part of an expression with numbers and pronumerals connected only by multiplication and division
 - A **coefficient** is the number part in front of a term
 - A **constant term** is a term that does not contain any pronumerals
 - This is an example of a 3-term expression

$$7y^2 + 2xy - 4$$

- **Like terms** have the same pronumeral part.
 - They can be collected using addition and subtraction.
For example: $5a - 7a = -2a$ and $3xy^2 + 2y^2x = 5xy^2$
- For multiplication and division, the symbols × and ÷ are not usually shown.
For example: $(-3 \times a \times b) \times (2 \times b) = -3ab \times 2b = -6ab^2$

$$14a^2b \div (7ab) = \frac{14a^2b}{7ab} = 2a$$

- The **distributive law** is used to expand brackets.

For example: $-3(x - 2) = -3x + 6$

$$4x + 2(1 - x) = 4x + 2 - 2x = 2x + 2$$

- To evaluate an expression, substitute a value for each pronumeral and simplify.
For example: if $a = 2$ and $b = -3$ then

$$\begin{aligned} b^2 - a &= (-3)^2 - 2 \\ &= 9 - 2 \\ &= 7 \end{aligned}$$

Exercise 9A

Understanding

1–3

3

- Write expressions for each of the following.
 - The cost of:
 - x movie passes at \$11 each
 - n apples at 50 cents each
 - The number of tickets purchased for:
 - x adults and y children
 - b boys and g girls
 - The cost of hiring an electrician for n hours if the callout fee is \$50 and the cost of labour is \$60 per hour
- Consider the expression $5x - 2xy - y^2 - 7$.
 - What is the coefficient of x ?
 - What is the coefficient of xy ?
 - What is the constant term?
 - Are there any like terms?
 - Evaluate the expression if $x = 1$ and $y = 2$.
 - Evaluate the expression if $x = 2$ and $y = -1$.
- Write expressions for the following.
 - The sum of 5 and $2x$.
 - 7 less than $4a$.
 - 1 less than the square of y .
 - The product of x and z .
 - The sum of the squares of a and b .
 - The square root of 8 more than x .

Hint: Remember to include the negative sign in the coefficient of xy .



Hint: 'Product' means multiply.



Fluency

4–6(½)

4–6(½)

Example 1 Collecting like terms

Collect like terms to simplify the following.

a $5y - x + 2y$

b $4a^2b + ab - ba^2$

Solution

Explanation

a $5y - x + 2y = 7y - x$

$5y$ and $2y$ are like terms.

b $4a^2b + ab - ba^2 = 3a^2b + ab$

$4a^2b$ and ba^2 (or a^2b) are like terms and $4 - 1 = 3$.

Now you try

Collect like terms to simplify the following.

a $7m + 2n - 5m - 3n$

b $2x^2y - xy - 4yx^2$

4 Simplify by collecting like terms.

a $3a - 4a$

b $4x + 7x$

c $6ab + 2ab$

d $5xy - 9xy$

e $3a - 1 - 2a$

f $7y + 2x - 11y$

g $5x - y - 3y + x$

h $ab + ba$

i $a^2b - 5a^2b - 3$

j $11xy - 14yx$

k $10r^2a + 2ar^2$

l $9st^2 - st - 8t^2s$

Hint: Only collect 'like' terms.
Note that $ab = ba$.**Example 2 Multiplying and dividing terms**

Simplify these expressions.

a $-4a \times 2ab$

b $21a^2b \div (3abc)$

Solution

a $-4a \times 2ab = -8a^2b$

Explanation

$-4 \times 2 = -8$ and $a \times a = a^2$

b $21a^2b \div (3abc) = \frac{21a^2b}{3abc}$
 $= \frac{7a}{c}$

Write as a fraction then cancel where possible.

Note: $\frac{a^2}{a} = \frac{a \times a^1}{a^1} = a$

Now you try

Simplify these expressions.

a $5xy \times (-3y)$

b $6a^2b \div (12ab)$

5 Simplify the following.

a $5 \times 3x$

b $7a \times 2$

c $-4x \times 2y$

d $6a \times (-7a)$

e $-3ab \times b$

f $-6a^2b \times 2b$

g $4x \div 2$

h $7a \div a$

i $12a \div (4a)$

j $22a^2 \div (11a)$

k $40a \div (4a^2)$

l $100x^2y \div (25xy)$

m $\frac{7ab^2}{7b}$

n $\frac{48a^2bc}{16abc^2}$

o $\frac{12xy}{36xy^2}$

**Example 3 Expanding brackets**

Use the distributive law to expand and simplify:

a $-x(2 + x)$

b $4x - 2(x - 1)$

Solution

a $-x(2 + x) = -2x - x^2$

Explanation

$-x \times 2 = -2x$ and $-x \times x = -x^2$

b $4x - 2(x - 1) = 4x - 2x + 2$
 $= 2x + 2$

First expand the brackets then collect like terms.
Note: $-2 \times (-1) = 2$, not -2 .

9A

Now you try

Use the distributive law to expand and simplify:

a $-3(x+2)$

b $-4x(1-x) + 2x^2$

6 Use the distributive law to expand and simplify:

a $3(x+2)$

b $2(4+x)$

c $-3(x+4)$

d $-6(x+1)$

e $-2(x-3)$

f $-x(x+1)$

g $-3y(2-3y)$

h $-7a(a-b)$

i $3+2(x-1)$

j $3x+4(1-x)$

k $3(x+1)-7x$

l $4(x+2)-2(x+1)$

m $7(x-3)-3(x-4)$

n $-4(1-x)-21x+1$

o $-6(2-x)-7(4-x)$

p $-2(3-x)-(5-x)$

Hint: Remember: a negative times a negative is a positive.



Problem-solving and reasoning

7, 8(½), 9

8(½), 9–11

7 For these shapes, write expressions for **i** perimeter and **ii** area.

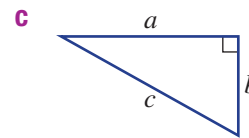
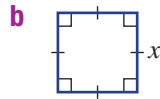
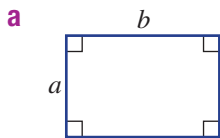

8 Evaluate the following if $a = 3$, $b = -2$ and $c = -4$.

a $2a+b$

b abc

c $2a \div (3b)$

d $-3c+b$

e a^2+b^2

f $c^2 \div b$

g $\frac{a^2+c^2}{2}$

h $\frac{a-c}{7}$

i $\frac{1}{a}(b+c)$

j a^3-b^3

k $2b^3-c$

l $\sqrt{a^2+b^2}$

Hint: Substitute pronumeral values and work out the answer.



9 You can hire a sports car for an upfront fee of \$100 plus \$80 per hour after that.

a What is the cost of hiring a sports car for:

i 2 hours?

ii 9 hours?

b Write an expression for the cost of hiring a sports car for n hours.



10 Find the area of these shapes in expanded form. All angles are 90° .

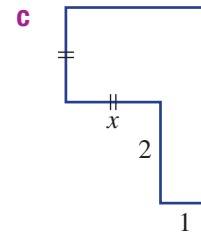
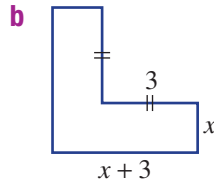
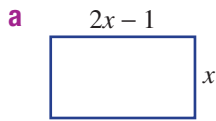

11 Identify the errors, then correct to find the answer.

a $-3(x - 1)$
 $= -3x - 3$

b $\frac{3ab}{6b} = 2a$

c $\frac{4a}{2a^2} = 2a$

d $3(x + 2) - 3(x - 1)$
 $= 3x + 6 - 3x - 3$
 $= 3$



Jake vs Lucas

12

12 Jake and Lucas operate separate computer consulting services.

- Jake charges \$60 per hour.
- Lucas charges a \$40 callout fee plus \$50 per hour after that.

a What is the cost of hiring Jake for:

- i 2 hours? ii 10 hours?

b What is the cost of hiring Lucas for:

- i 2 hours? ii 10 hours?

c Write an expression for the cost of hiring Jake for n hours.

d Write an expression for the cost of hiring Lucas for n hours.

e After what time is the cost of hiring Jake or Lucas the same?



9B Expanding binomial products

Learning intentions

- To understand the distributive law for expanding binomial products
- To be able to expand and simplify binomial products

Key vocabulary: binomial product, distributive law, expand

A binomial is an expression with two terms such as $x + 5$ or $x^2 + 3$. You will recall from the previous section that we looked at the product of a single term with a binomial expression; e.g. $2(x - 3)$ or $x(3x - 1)$.

The product of two binomial expressions can also be expanded using the distributive law. This involves multiplying every term in one expression by every term in the other expression.



Expanding the product of two expressions can be applied to problems involving the expansion of rectangular areas, such as a farmer's paddocks.

Lesson starter: Rectangular expansions

If $(x + 1)$ and $(x + 2)$ are the side lengths of a rectangle as shown, the total area can be found as an expression in two different ways.

- Write an expression for the total area of the rectangle using length = $(x + 2)$ and width = $(x + 1)$.
- Now find the area of each of the four parts of the rectangle and combine to give an expression for the total area.
- Compare your two expressions above and complete this equation:

$$(x + 2)(\quad) = x^2 + \quad + \quad.$$

- Can you explain a method for expanding the left-hand side to give the right-hand side?

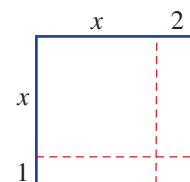

Key ideas

- A binomial is an expression with two terms.
- Expanding **binomial products** uses the distributive law.

$$\begin{aligned}(a + b)(c + d) &= a(c + d) + b(c + d) \\ &= ac + ad + bc + bd\end{aligned}$$

- Diagrammatically

$$(a + b)(c + d) = ac + ad + bc + bd$$

$$\begin{aligned}\text{For example: } (x + 3)(x + 5) &= x^2 + 5x + x + 5 \\ &= x^2 + 6x + 5\end{aligned}$$

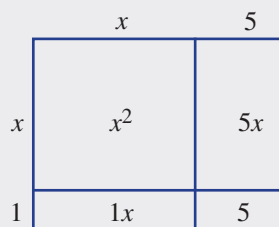
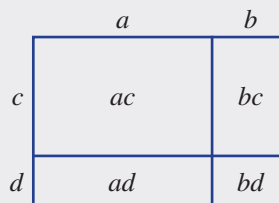

Exercise 9B

Understanding

1–3

2, 3

- 1 The given diagram shows the area $(x+2)(x+3)$.
- a** Write down an expression for the area of each of the four regions inside the rectangle.
- b** Copy and complete: $(x+2)(x+3) = \underline{\hspace{2cm}} + 3x + \underline{\hspace{2cm}} + 6$
 $= \underline{\hspace{2cm}} + 5x + \underline{\hspace{2cm}}$

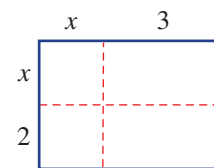

- 2 The given diagram shows the area $(2x+3)(x+1)$.
- a** Write down an expression for the area of each of the four regions inside the rectangle.
- b** Copy and complete: $(2x+3)(\underline{\hspace{2cm}}) = 2x^2 + \underline{\hspace{2cm}} + 3x + \underline{\hspace{2cm}}$
 $= \underline{\hspace{2cm}} + \underline{\hspace{2cm}} + \underline{\hspace{2cm}}$

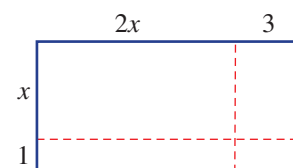

- 3 Copy and complete these expansions
- a** $(x+1)(x+5) = \underline{\hspace{2cm}} + 5x + \underline{\hspace{2cm}} + 5$
 $= \underline{\hspace{2cm}} + 6x + \underline{\hspace{2cm}}$
- b** $(x-3)(x+2) = \underline{\hspace{2cm}} + \underline{\hspace{2cm}} - 3x - \underline{\hspace{2cm}}$
 $= \underline{\hspace{2cm}} - x - \underline{\hspace{2cm}}$
- c** $(3x-2)(7x+2) = \underline{\hspace{2cm}} + 6x - \underline{\hspace{2cm}} - \underline{\hspace{2cm}}$
 $= \underline{\hspace{2cm}} - \underline{\hspace{2cm}} - \underline{\hspace{2cm}}$
- d** $(4x-1)(3x-4) = \underline{\hspace{2cm}} - \underline{\hspace{2cm}} - 3x + \underline{\hspace{2cm}}$
 $= \underline{\hspace{2cm}} - 19x + \underline{\hspace{2cm}}$

Hint: The product is negative if there are opposite signs (+, -) or (-, +) and positive if they are the same sign (+, +) or (-, -).



Fluency

4–5(1/2)

4–5(1/2)



Example 4 Expanding binomial products

Expand $(x+3)(x+5)$.

Solution

$$\begin{aligned} (x+3)(x+5) &= x^2 + 5x + 3x + 15 \\ &= x^2 + 8x + 15 \end{aligned}$$

Explanation

Use the distributive law to expand the brackets and then collect the like terms $5x$ and $3x$.

Now you try

Expand $(x+2)(x+9)$.

- 4 Expand the following.
- a** $(x+2)(x+5)$ **b** $(b+3)(b+4)$ **c** $(t+8)(t+7)$
d $(p+6)(p+6)$ **e** $(x+9)(x+6)$ **f** $(d+15)(d+4)$
g $(a+1)(a+7)$ **h** $(y+10)(y+2)$ **i** $(m+4)(m+12)$

Hint: First expand with the distributive law then collect the two like terms.



9B

Example 5 Expanding binomial products involving subtraction signs

Expand the following.

a $(x - 4)(x + 7)$

b $(2x - 1)(x - 6)$

c $(5x - 2)(3x + 7)$

Solution**Explanation**

$$\begin{aligned} \mathbf{a} \quad (x - 4)(x + 7) &= x^2 + 7x - 4x - 28 \\ &= x^2 + 3x - 28 \end{aligned}$$

After expanding to get the four terms, collect the like terms $7x$ and $-4x$.Note: $x \times 7 = 7x$ and $-4 \times x = -4x$.

$$\begin{aligned} \mathbf{b} \quad (2x - 1)(x - 6) &= 2x^2 - 12x - x + 6 \\ &= 2x^2 - 13x + 6 \end{aligned}$$

Remember: $2x \times x = 2x^2$ and $-1 \times (-6) = 6$.

$$\begin{aligned} \mathbf{c} \quad (5x - 2)(3x + 7) &= 15x^2 + 35x - 6x - 14 \\ &= 15x^2 + 29x - 14 \end{aligned}$$

Recall: $5x \times 3x = 5 \times 3 \times x \times x = 15x^2$.**Now you try**

Expand the following.

a $(x + 3)(x - 6)$

b $(3x - 2)(x - 4)$

c $(6x + 5)(3x - 4)$

5 Expand the following.

a $(x + 3)(x - 4)$

b $(x + 5)(x - 2)$

c $(x + 4)(x - 8)$

d $(x - 6)(x + 2)$

e $(x - 1)(x + 10)$

f $(x - 7)(x + 9)$

g $(x - 2)(x + 7)$

h $(x - 1)(x - 2)$

i $(x - 4)(x - 5)$

j $(4x + 3)(2x + 5)$

k $(3x + 2)(2x + 1)$

l $(3x + 1)(5x + 4)$

m $(2x - 3)(3x + 5)$

n $(8x - 3)(3x + 4)$

o $(3x - 2)(2x + 1)$

p $(5x + 2)(2x - 7)$

q $(2x + 3)(3x - 2)$

r $(4x + 1)(4x - 5)$

s $(3x - 2)(6x - 5)$

t $(5x - 2)(3x - 1)$

u $(7x - 3)(3x - 4)$

Hint: First expand with the distributive law then collect the two like terms.



Problem-solving and reasoning

6–8, 9(½)

7–11

6 A 10 m by 7 m rectangular factory shed is expanded by x metres on two sides.**a** Write expressions for:

- i** the new length of the shed (horizontal length)
- ii** the new width of the shed (vertical length)

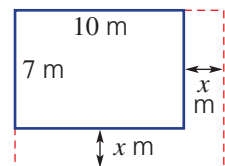
b Using your results from part **a**, expand brackets to find an expression for the new total area.**c** What would be the new area if $x = 2$?**7** A rectangular room in a house with dimensions 4 m by 5 m is to be extended. Both the length and width are to be increased by x m.**a** Find an expanded expression for the area of the new room.

- b i** If $x = 3$, find the area of the new room.
- ii** By how much has the area increased?

Hint: First label the length and width of the new room.

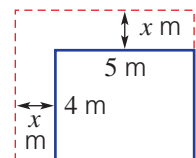

- 8 A rectangular trampoline of length 3 m and width 2 m is to be surrounded by padding of width x metres.

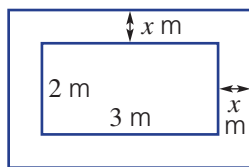

- a Write expressions for:
 i the total length of the trampoline and padding
 ii the total width of the trampoline and padding
 b Find an expression for the total area by expanding brackets.
 c What would be the total area if $x = 1$?

Hint: Don't forget to count the x on both sides.



- 9 Write the missing terms in these expansions.

a $(x + 2)(x + \underline{\quad}) = x^2 + 5x + 6$

b $(x + \underline{\quad})(x + 5) = x^2 + 7x + 10$

c $(x + 1)(x + \underline{\quad}) = x^2 + 7x + \underline{\quad}$

d $(x + \underline{\quad})(x + 9) = x^2 + 11x + \underline{\quad}$

e $(x + 3)(x - \underline{\quad}) = x^2 + x - \underline{\quad}$

f $(x - 5)(x + \underline{\quad}) = x^2 - 2x - \underline{\quad}$

- 10 Expand these binomial products.

a $(a + b)(a + c)$

b $(a - b)(a + c)$

c $(b - a)(a + c)$

d $(2x + y)(x - 2y)$

e $(2a + b)(a - b)$

f $(3x - y)(2x + y)$

- 11 A picture frame 5 cm wide has a length that is twice the width, x cm.

- a Find an expression for the total area of the frame and picture.
 b Find an expression in expanded form for the area of the picture only.

Hint: Length of picture = $2x - 5 - 5 = 2x - 10$

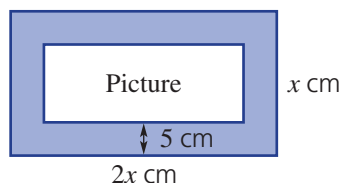

Paving the pool

—

12

- 12 The outside edge of a path around a rectangular swimming pool is 15 m long and 10 m wide. The path is x metres wide.

- a Write expressions for:
 i the length of the pool
 ii the width of the pool
 b Find an expression for the area of the pool in expanded form.
 c Find the area of the pool if $x = 2$.
 d What value of x makes the pool area 50 m^2 ? Use trial and error.

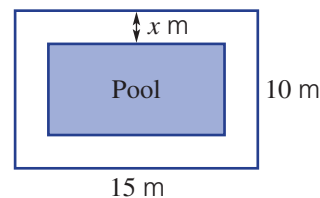

9C Expanding perfect squares

Learning intentions

- To be able to recognise a perfect square
- To understand that expressions that are perfect squares can be expanded
- To be able to expand and simplify perfect squares

Key vocabulary: perfect square, distributive law, expand

A special type of binomial product involves perfect squares. Examples of perfect squares are $2^2 = 4$, $15^2 = 225$, x^2 and $(a + b)^2$. To expand $(a + b)^2$ we multiply $(a + b)$ by $(a + b)$ and use the distributive law:

$$\begin{aligned}(a + b)^2 &= (a + b)(a + b) \\ &= \overbrace{a(a + b)} + \overbrace{b(a + b)} \\ &= a^2 + ab + ba + b^2 \\ &= a^2 + 2ab + b^2\end{aligned}$$

A similar result is obtained for the square of $(a - b)$:

$$\begin{aligned}(a - b)^2 &= (a - b)(a - b) \\ &= \overbrace{a(a - b)} - \overbrace{b(a - b)} \\ &= a^2 - ab - ba + b^2 \\ &= a^2 - 2ab + b^2\end{aligned}$$

→ Lesson starter: Seeing the pattern

Using $(a + b)(c + d) = ac + ad + bc + bd$, expand and simplify the binomial products below.

$$(x + 1)(x + 1) = x^2 + x + x + 1 \qquad (x - 5)(x - 5) =$$

$$=$$

$$(x + 3)(x + 3) = \qquad (x - 7)(x - 7) =$$

$$=$$

- Describe the patterns you see in the expansions above.
- Generalise your observations by completing the following expansions.

$$\begin{aligned}(a + b)(a + b) &= a^2 + \underline{\quad} + \underline{\quad} + \underline{\quad} & (a - b)(a - b) &= \\ &= a^2 + \underline{\quad} + \underline{\quad} & &= \end{aligned}$$

Key ideas

- $3^2 = 9$, a^2 , $(2y)^2$, $(x - 1)^2$ and $(3 - 2y)^2$ are all examples of **perfect squares**. They are expressions that can be written as a single square.
- Expanding perfect squares:

$$\begin{aligned}(a + b)^2 &= (a + b)(a + b) \\ &= \overbrace{a(a + b)} + \overbrace{b(a + b)} \\ &= a^2 + ab + ba + b^2 \\ &= a^2 + 2ab + b^2\end{aligned}$$

$$\begin{aligned}(a - b)^2 &= (a - b)(a - b) \\ &= \overbrace{a(a - b)} - \overbrace{b(a - b)} \\ &= a^2 - ab - ba + b^2 \\ &= a^2 - 2ab + b^2\end{aligned}$$

Exercise 9C

Understanding

1-3

3

- 1 The side lengths of this square are $(x + 3)$ units.
- a** What are the areas of each of the four regions? Write expressions each time.
- b** Add up all the area expressions to find an expression for the total area.

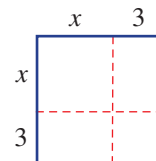

c Complete the following: $(x + 3)(x + 3) = x^2 + 3x + \underline{\quad} + \underline{\quad}$
 $= x^2 + 6x + \underline{\quad}$

- 2 Complete these expansions.

a $(x + 4)(x + 4) = x^2 + 4x + \underline{\quad} + \underline{\quad}$
 $= \underline{\hspace{2cm}}$

b $(x + 5)(x + 5) = x^2 + 5x + \underline{\quad} + \underline{\quad}$
 $= \underline{\hspace{2cm}}$

c $(x - 2)(x - 2) = x^2 - 2x - \underline{\quad} + \underline{\quad}$
 $= \underline{\hspace{2cm}}$

d $(x - 7)(x - 7) = x^2 - 7x - \underline{\quad} + \underline{\quad}$
 $= \underline{\hspace{2cm}}$

Hint: Expand using the distributive law:
 $(a + b)(c + d) = ac + ad + bc + bd$



- 3 **a** Substitute the given value of b into $x^2 + 2bx + b^2$ and simplify.

i $b = 3$

ii $b = 11$

- b** Substitute the given value of b into $x^2 - 2bx + b^2$ and simplify.

i $b = 2$

ii $b = 9$

Fluency

4-5(1/2)

4-6(1/2)



Example 6 Expanding perfect squares

Expand each of the following.

a $(x + 3)^2$

Solution

a $(x + 3)^2 = (x + 3)(x + 3)$
 $= x^2 + 3x + 3x + 9$
 $= x^2 + 6x + 9$

Alternative solution:

$(x + 3)^2 = x^2 + 2 \times x \times 3 + 3^2$
 $= x^2 + 6x + 9$

b $(x - 2)^2$

Explanation

Write in expanded form.
 Use the distributive law.
 Collect like terms.

Expand using $(a + b)^2 = a^2 + 2ab + b^2$,
 where $a = x$ and $b = 3$.

b $(x - 2)^2 = (x - 2)(x - 2)$
 $= x^2 - 2x - 2x + 4$
 $= x^2 - 4x + 4$

Alternative solution:

$(x - 2)^2 = x^2 - 2 \times x \times 2 + 2^2$
 $= x^2 - 4x + 4$

Write in expanded form.
 Use the distributive law.
 Collect like terms.

Expand using $(a - b)^2 = a^2 - 2ab + b^2$
 where $a = x$ and $b = 2$.

Now you try

Expand each of the following.

a $(x + 8)^2$

b $(x - 5)^2$

- 8 A child at pre-school cuts off a strip of width x cm from two sides of a square piece of paper of side length 10 cm.
- Write an expression for the new side length of the remaining paper.
 - Find the area of the new piece of paper in expanded form.
 - Use your result to find the new area if:
 - $x = 2$
 - $x = 6$
 - What value of x makes the new area one quarter of the original?

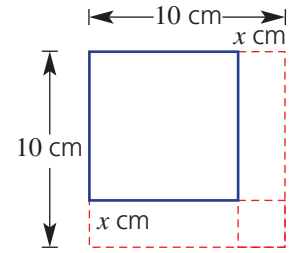

- 9 A square piece of tin of side length 20 cm has four squares of side length x cm removed from each corner. The sides are folded up to form a tray. The centre square forms the tray base.
- Write an expression for the side length of the base of the tray.
 - Write an expression for the area of the base of the tray. Expand your answer.
 - Find the area of the tray base if $x = 3$.
 - Find the volume of the tray if $x = 3$.

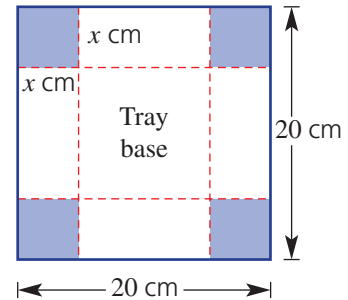

Hint: For part **d**, what is the height of the tray?



- 10 A square of side length b is removed from a square of side length a .
- Using subtraction, write down an expression for the remaining area.
 - Write expressions for the area of the regions in expanded form:
 - A
 - B
 - C
 - Add all the expressions from part **b** to see if you get your answer from part **a**.

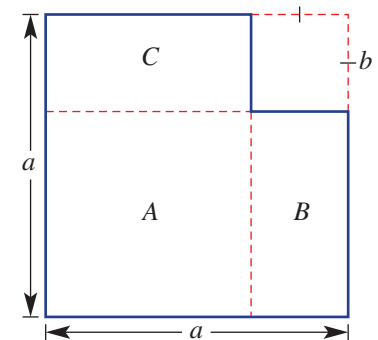

Arranging tennis courts

—

11

- 11 Four tennis courts are arranged as shown, with a square storage space in the centre. Each court area has the same dimensions, $a \times b$.
- Write an expression for the side length of the total area.
 - Write an expression for the area of the total area.
 - Write an expression for the side length of the inside storage space.
 - Write an expression for the area of the storage space in expanded form.
 - Subtract your answer to part **d** from your answer to part **b** to find the area of the four courts.
 - Find the area of one court. Does your answer confirm that your answer to part **e** is correct?

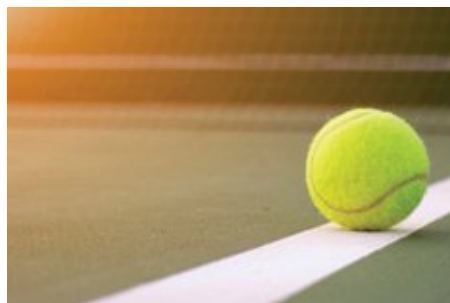
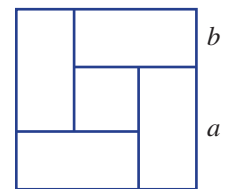

9D Forming a difference of perfect squares

Learning intentions

- To understand how a difference of perfect squares is formed
- To be able to expand and simplify to form a difference of perfect squares

Key vocabulary: difference of perfect squares, distributive law, expand

Another type of expansion deals with the product of the sum and difference of the same two terms. The result is the difference of two perfect squares:

$$\begin{aligned}(a+b)(a-b) &= a(a-b) + b(a-b) \quad \text{or} \quad (a+b)(a-b) = a^2 - ab + ba - b^2 \\ &= a^2 - ab + ba - b^2 & &= a^2 - b^2 \\ &= a^2 - b^2\end{aligned}$$

→ Lesson starter: How is 16×14 a difference of perfect squares?

Using the fact that $15^2 = 225$, follow these steps to show how 16×14 can be calculated mentally using a difference of perfect squares.

- $16 \times 14 = (15 + \underline{\quad}) \times (15 - \underline{\quad})$ Rewrite.
 $= 15^2 - \underline{\quad} + \underline{\quad} - \underline{\quad}$ Expand.
 $= \underline{\quad} - 1$ Simplify.
 $= \underline{\quad}$ Evaluate.
- Now try this technique on 17×13 and 19×21 .

Key ideas

- A **difference of perfect squares** (DOPS) is formed when one square is subtracted from another.
- This is formed when $(a+b)(a-b)$ is expanded and simplified.

$$\begin{aligned}(a+b)(a-b) &= a^2 - ab + ba - b^2 \\ &= a^2 - b^2\end{aligned}$$

$(a-b)(a+b)$ also expands to $a^2 - b^2$
The result is a difference of two perfect squares.

Exercise 9D

Understanding

1-3

2, 3

- Why do the two middle terms in an expansion of $(x+a)(x-a)$ (i.e. $x^2 + ax - xa - a^2$) cancel out?
- Decide whether each of the following shows a single perfect square or a difference of perfect squares.
 - 4^2
 - $7^2 - 3^2$
 - $a^2 - b^2$
 - x^2
- Complete these expansions.

a $(x+4)(x-4) = x^2 - 4x + \underline{\quad} - \underline{\quad}$
 $= \underline{\quad}$

b $(2x-1)(2x+1) = 4x^2 + \underline{\quad} - \underline{\quad} - \underline{\quad}$
 $= \underline{\quad}$

Hint:

$$\begin{aligned}(a+b)(a-b) &= a^2 - ab + ab - b^2 \\ &= a^2 - b^2\end{aligned}$$



Fluency

4-5(1/2)

4-5(1/2)



Example 8 Forming a difference of perfect squares

Expand and simplify the following.

a $(x + 2)(x - 2)$

b $(x - 7)(x + 7)$

Solution**Explanation**

$$\begin{aligned} \mathbf{a} \quad (x + 2)(x - 2) &= x^2 - \cancel{2x} + \cancel{2x} - 4 \\ &= x^2 - 4 \end{aligned}$$

Expand using the distributive law.
 $-2x + 2x = 0$.

Alternate solution:

$$\begin{aligned} (x + 2)(x - 2) &= (x)^2 - (2)^2 \\ &= x^2 - 4 \end{aligned}$$

 $(a + b)(a - b) = a^2 - b^2$. Here $a = x$ and $b = 2$.

$$\begin{aligned} \mathbf{b} \quad (x - 7)(x + 7) &= x^2 + 7x - 7x - 49 \\ &= x^2 - 49 \end{aligned}$$

Expand, then note that $7x - 7x = 0$.

Alternate solution:

$$\begin{aligned} (x - 7)(x + 7) &= (x)^2 - (7)^2 \\ &= x^2 - 49 \end{aligned}$$

 $(a - b)(a + b) = a^2 - b^2$, with $a = x$ and $b = 7$.
Now you try

Expand and simplify the following.

a $(x + 5)(x - 5)$

b $(x - 15)(x + 15)$

4 Expand and simplify the following to form a difference of perfect squares.

a $(x + 1)(x - 1)$

b $(x + 3)(x - 3)$

c $(x + 8)(x - 8)$

d $(x + 4)(x - 4)$

e $(x + 12)(x - 12)$

f $(x + 11)(x - 11)$

g $(x - 9)(x + 9)$

h $(x - 5)(x + 5)$

i $(x - 6)(x + 6)$

j $(5 - x)(5 + x)$

k $(2 - x)(2 + x)$

l $(7 - x)(7 + x)$

Hint: Recall:

$(a + b)(a - b) = a^2 - b^2$



Example 9 Forming more differences of perfect squares

Expand and simplify $(3x - 2y)(3x + 2y)$.**Solution****Explanation**

$$\begin{aligned} (3x - 2y)(3x + 2y) &= 9x^2 + \cancel{6xy} - \cancel{6xy} - 4y^2 \\ &= 9x^2 - 4y^2 \end{aligned}$$

Expand using the distributive law.
 $6xy - 6xy = 0$.

Alternate solution:

$$\begin{aligned} (3x - 2y)(3x + 2y) &= (3x)^2 - (2y)^2 \\ &= 9x^2 - 4y^2 \end{aligned}$$

 $(a + b)(a - b) = a^2 - b^2$, with $a = 3x$ and $b = 2y$ here. Recall that $(3x)^2 = 3x \times 3x$.
Now you tryExpand and simplify $(12x - 5y)(12x + 5y)$.

9D

5 Expand and simplify the following.

a $(3x - 2)(3x + 2)$

c $(4x - 3)(4x + 3)$

e $(9x - 5y)(9x + 5y)$

g $(8x + 2y)(8x - 2y)$

i $(7x - 5y)(7x + 5y)$

k $(8x - 3y)(8x + 3y)$

b $(5x - 4)(5x + 4)$

d $(7x - 3y)(7x + 3y)$

f $(11x - y)(11x + y)$

h $(10x - 9y)(10x + 9y)$

j $(6x - 11y)(6x + 11y)$

l $(9x - 4y)(9x + 4y)$

Hint:
 $(3x)^2 = 3x \times 3x$
 $= 9x^2$



Problem-solving and reasoning

6(½), 7

6(½), 8

6 To calculate 21×19 , here is a method using the difference of perfect squares.

$$21 \times 19 = (20 + 1)(20 - 1)$$

$$= 20^2 - 1^2$$

$$= 400 - 1$$

$$= 399$$

Use this technique to evaluate the following (mentally if you can).

a 31×29 (Note: $30^2 = 900$)

c 26×24 (Note: $25^2 = 625$)

e 22×18 (Use $20^2 = 400$)

g 35×25 (Use $30^2 = 900$)

b 41×39 (Note: $40^2 = 1600$)

d 51×49 (Note: $50^2 = 2500$)

f 23×17 (Use $20^2 = 400$)

h 54×46 (Use $50^2 = 2500$)

7 Lara is x years old and her two best friends are $(x - 2)$ and $(x + 2)$ years old.

a Write an expression for:

i the square of Lara's age

ii the product of the ages of Lara's best friends

b Are the answers from parts **a i** and **ii** equal? If not, by how much do they differ?

Hint: Expand in part **a ii**.



8 A square of side length x has one side reduced by 1 unit and the other increased by 1 unit.

a Find an expanded expression for the area of the resulting rectangle.

b Is the area of the original square the same as the area of the resulting rectangle? Explain why/why not.

Hint: Determine expressions for the length and width of the rectangle first.



Classroom renovation

—

9

9 A square classroom is to be shortened on the south side by 3 m and extended on the east side by 3 m. The original side length of the classroom was x m.

a Write expressions for:

i the original area of the classroom

ii the new length of the classroom

iii the new width of the classroom

b Expand to find an expression for the new area of the classroom.

c Is the new area the same as the original area? If not, by how much do they differ?

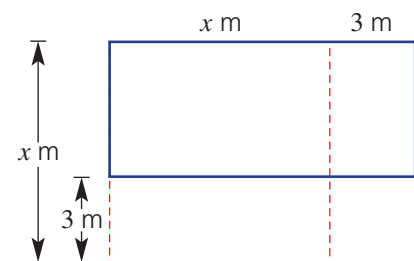

9E Factorising algebraic expressions

Learning intentions

- To understand that factorising and expanding are reverse processes
- To be able to identify the highest common factor
- To know the form of a factorised expression
- To be able to factorise algebraic expressions involving a common factor

Key vocabulary: highest common factor, factorise

The process of factorisation is a key step in the simplification of many algebraic expressions and in the solution of equations. It is the reverse process of expansion and involves writing an expression as a product of its factors.

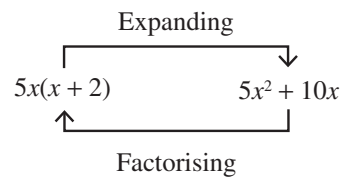

→ Lesson starter: Factorised areas

Here is a rectangle of length $(x + 3)$ and width x .

- Write an expression for the total area using the given length and width.
- Write an expression for the total area by adding up the area of the two smaller regions.
- Are your two expressions equivalent? How could you work from your second expression (expanded) to the first expression (factorised)?

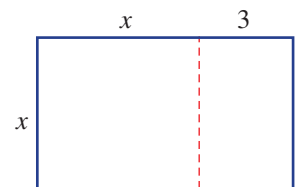

Key ideas

- To **factorise** means to write an expression as a product of its factors.
- When factorising expressions with common factors, take out the highest common factor (HCF). The HCF could be:
 - a number
For example: $2x + 10 = 2(x + 5)$
 - a pronumeral
For example: $x^2 + 5x = x(x + 5)$
 - the product of numbers and pronumerals
For example: $2x^2 + 10x = 2x(x + 5)$
- A factorised expression can be checked by using expansion.
 - For example: $2x(x + 5) = 2x^2 + 10x$.

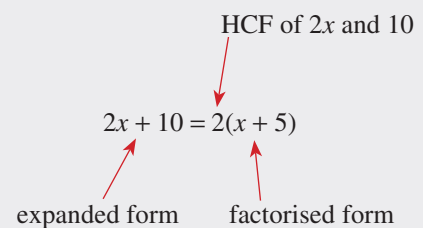

Exercise 9E

Understanding

1–3

3

- 1 Write down the highest common factor (HCF) of these pairs of numbers.
- a** 8, 12 **b** 10, 20 **c** 5, 60 **d** 24, 30
- 2 Write down the missing factor.
- a** $5 \times \underline{\quad} = 5x$
b $7 \times \underline{\quad} = 7x$
c $2a \times \underline{\quad} = 2a^2$
d $5a \times \underline{\quad} = 10a^2$
e $\underline{\quad} \times 3y = -6y^2$
f $\underline{\quad} \times 12x = -36x^2$
- 3 **a** Write down the missing factor in each part.
- i** $\underline{\quad}(x^2 + 2x) = 6x^2 + 12x$
ii $\underline{\quad}(2x + 4) = 6x^2 + 12x$
iii $\underline{\quad}(x + 2) = 6x^2 + 12x$
- b** Which equation above uses the HCF of $6x^2$ and $12x$?

Fluency

4–6(½)

4–6(½)



Example 10 Finding the highest common factor (HCF)

Determine the HCF of the following.

a $6a$ and $8ab$

b $3x^2$ and $6xy$

Solution

Explanation

a HCF of $6a$ and $8ab$ is $2a$

HCF of 6 and 8 is 2.
 HCF of a and ab is a .

b HCF of $3x^2$ and $6xy$ is $3x$

HCF of 3 and 6 is 3.
 HCF of x^2 and xy is x .

Now you try

Determine the HCF of the following.

a $10ab$ and $5b$

b $7xy^2$ and $21xy$

- 4 Determine the HCF of the following.
- a** $6x$ and $14xy$ **b** $12a$ and $18a$ **c** $10m$ and 4
d $12y$ and 8 **e** $15t$ and $6s$ **f** 15 and p
g $9x$ and $24xy$ **h** $6n$ and $21mn$ **i** $10y$ and $2y$
j $8x^2$ and $14x$ **k** $4x^2y$ and $18xy$ **l** $5ab^2$ and $15a^2b$

Hint: HCF stands for highest common factor.



**Example 11 Factorising expressions**

Factorise the following.

a $4x + 12$

b $10y - 25y^2$

Solution**Explanation**

a $4x + 12 = 4(x + 3)$

4 is the HCF of $4x$ and 12 .
Place 4 in front of the brackets
and divide each term by 4:
 $4x \div 4 = x$ and $12 \div 4 = 3$.
Check your answer using expansion.

b $10y - 25y^2 = 5y(2 - 5y)$

The HCF of $10y$ and $25y^2$ is $5y$. Place $5y$ in front
of the brackets and divide each term by $5y$.

Now you try

Factorise the following.

a $15a + 20$

b $2x^2 - 6x$

5 Factorise the following.

a $7x + 7$

b $3x + 3$

c $4x - 4$

d $5x - 5$

e $4 + 8y$

f $10 + 5a$

g $3 - 9b$

h $6 - 2x$

i $12a + 3b$

j $6m + 6n$

k $10x - 8y$

l $4a - 20b$

m $x^2 + 2x$

n $a^2 - 4a$

o $y^2 - 7y$

p $x - x^2$

q $3p^2 + 3p$

r $8x - 8x^2$

s $4b^2 + 12b$

t $6y - 10y^2$

Hint: Always take out the highest
common factor (HCF).

**Example 12 Taking out the common negative sign**Factorise $-8x^2 - 12x$.**Solution****Explanation**

$$-8x^2 - 12x = -4x(2x + 3)$$

The HCF of the terms is $-4x$, including the
common negative. Place the factor in front of
the brackets and divide each term by $-4x$.
Note: $-8x^2 \div (-4x) = 2x$ and $-12x \div (-4x) = 3$.

Now you tryFactorise $-11a - 22a^2$.**6** Factorise the following by including the negative sign in the common factor.

a $-8x - 4$

b $-4x - 2$

c $-10x - 5y$

d $-7a - 14b$

e $-9x - 12$

f $-6y - 8$

g $-10x - 15y$

h $-4m - 20n$

i $-3x^2 - 18x$

j $-8x^2 - 12x$

k $-16y^2 - 6y$

l $-5a^2 - 10a$

Hint: Take a negative factor out
of both terms.



Problem-solving and reasoning

7, 8(½)

8(½), 9–11

7 Write the missing number or expression.

a $3x + 9 = \underline{\hspace{1cm}}(x + 3)$

b $xy + x = x(\underline{\hspace{1cm}} + 1)$

c $a^2 - a = \underline{\hspace{1cm}}(a - 1)$

d $5xy + 10x = \underline{\hspace{1cm}}(y + 2)$

e $-7a - 14 = \underline{\hspace{1cm}}(a + 2)$

f $-24a^2 - 36a = \underline{\hspace{1cm}}(2a + 3)$

8 Write down the perimeter of these shapes in factorised form.

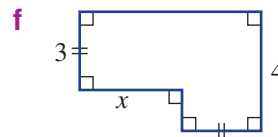
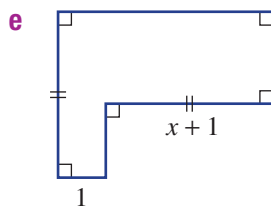
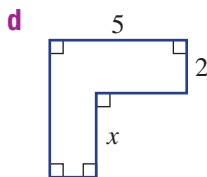
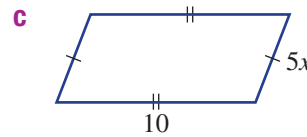
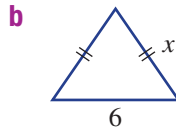
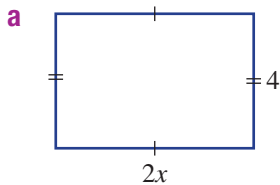

Hint: First find an expression for the perimeter, then factorise it.

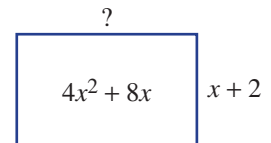
9 The expression for the area of a rectangle is $(4x^2 + 8x)$. Find an expression for its width if the length is $(x + 2)$.10 The height, in metres, of a ball thrown in the air is given by $5t - t^2$, where t is the time in seconds.

a Write an expression for the ball's height in factorised form.

b Find the ball's height at these times:

i $t = 0$

ii $t = 2$

iii $t = 4$

c How long does it take for the ball's height to return to 0 metres? Use trial and error if required.

11 $7 \times 9 + 7 \times 3$ can be evaluated by first factorising to $7(9 + 3)$. This gives $7 \times 12 = 84$. Use a similar technique to evaluate the following.

a $9 \times 2 + 9 \times 5$

b $6 \times 3 + 6 \times 9$

c $-2 \times 4 - 2 \times 6$

d $-5 \times 8 - 5 \times 6$

e $23 \times 5 - 23 \times 2$

f $63 \times 11 - 63 \times 8$



Further factorisation

—

12, 13

12 Common factors can also be removed from expressions with more than two terms.

For example: $2x^2 + 6x + 10xy = 2x(x + 3 + 5y)$

Factorise these expressions by taking out the HCF.

a $3a^2 + 9a + 12$

b $5z^2 - 10z + zy$

c $x^2 - 2xy + x^2y$

d $4by - 2b + 6b^2$

e $-12xy - 8yz - 20xyz$

f $3ab + 4ab^2 + 6a^2b$

13 You can factorise some expressions by taking out a binomial factor.

For example: $3(x - 2) + x(x - 2) = (x - 2)(3 + x)$

Factorise the following by taking out a binomial common factor.

a $4(x + 3) + x(x + 3)$

b $3(x + 1) + x(x + 1)$

c $7(m - 3) + m(m - 3)$

d $x(x - 7) + 2(x - 7)$

e $8(a + 4) - a(a + 4)$

f $5(x + 1) - x(x + 1)$

g $y(y + 3) - 2(y + 3)$

h $a(x + 2) - x(x + 2)$

i $t(2t + 5) + 3(2t + 5)$

j $m(5m - 2) + 4(5m - 2)$

k $y(4y - 1) - (4y - 1)$

l $(7 - 3x) + x(7 - 3x)$

Hint: $x - 2$ is the common factor.



- 9A** 1 Simplify the following.
- a** $3x - 2y + 5x - 4y$ **b** $3ab^2 - ab + 4ab^2$
c $4a \times 5ab$ **d** $\frac{3xy^2}{9xy}$
- 9A** 2 Expand and simplify the following.
- a** $3(x - 4)$ **b** $2y(3y + 5)$ **c** $5 - 2(3x + 1)$
- 9B** 3 Expand the following binomial products.
- a** $(x + 4)(x + 6)$ **b** $(x + 3)(x - 2)$
c $(2x - 3)(x + 4)$ **d** $(3x - 2)(2x - 5)$
- 9C** 4 Expand the following perfect squares.
- a** $(x + 6)^2$ **b** $(x - 8)^2$ **c** $(3x + 7)^2$ **d** $(5 - x)^2$

- 9B/9C** 5 Find the area of these figures in expanded form.

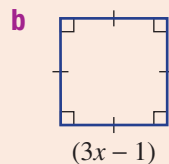
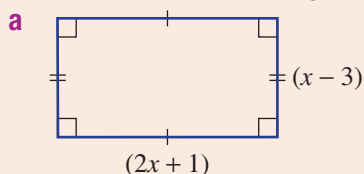

- 9D** 6 Expand and simplify the following.
- a** $(x + 10)(x - 10)$ **b** $(x - 1)(x + 1)$
c $(3x + 2)(3x - 2)$ **d** $(4x - 5y)(4x + 5y)$

- 9C/9D** 7 Expand and simplify $(x + 1)^2 - (x + 1)(x - 1)$.

- 9E** 8 Determine the HCF of the following.
- a** $8x$ and 12 **b** $6a$ and $15a$
c $5ab$ and $10ab^2$ **d** $12x^2$ and $9x$

- 9E** 9 Factorise the following. Take a negative factor out in parts **e** and **f**.
- a** $6x + 12$ **b** $15y - 20$ **c** $8ab + 20a$
d $4x^2 - 2x$ **e** $-10x - 5$ **f** $-4x^2 - 10x$

- 9E** 10 Give the perimeter of these shapes in factorised form

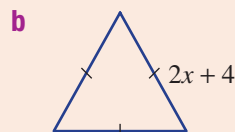
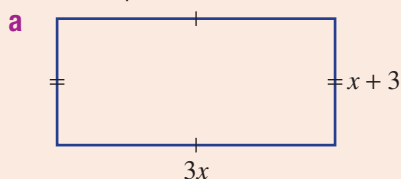

9F Simplifying algebraic fractions: multiplication and division

Learning intentions

- To know that expressions must be factorised before common factors can be cancelled
- To be able to simplify algebraic fractions by cancelling common factors
- To be able to multiply and divide algebraic fractions

Key vocabulary: algebraic fraction, common factor, factorise, numerator, denominator, reciprocal

Fractions such as $\frac{4}{6}$ and $\frac{24}{16}$ can be simplified by cancelling common factors. This is also true of algebraic fractions such as $\frac{3x}{6}$, $\frac{5a^2}{10a}$ and $\frac{2x+4}{2}$.

 **Lesson starter: Does $\frac{2x+6^3}{2^1} = 2x+3$?**

For the expression $\frac{2x+6}{2}$, a student attempts to cancel the 6 with the 2 in the denominator.

They write $\frac{2x+6^3}{2^1} = 2x+3$.

- Is this a correct method?
- Substitute $x = 1$ into the left hand side and then the right hand side. Are they equal?
- Can you show a correct method? Does it involve factorisation?

Key ideas

- Simplify **algebraic fractions** by cancelling **common factors**

$$\frac{3^1x}{6^2} = \frac{x}{2} \quad \frac{5a^2}{3a} = \frac{5a}{3} \quad \frac{2x+4}{2} = \frac{2^1(x+2)}{2^1} = x+2$$

- This is an incorrect cancellation: $\frac{2x+4^2}{2^1} = 2x+2$

- To multiply algebraic fractions, first cancel any numerator with any denominator.

$$\frac{2^1x^1}{5_1} \times \frac{15^3}{4_2x^1y} = \frac{1 \times 3}{1 \times 2y} = \frac{3}{2y}$$

- To divide algebraic fractions, multiply by the reciprocal of the fraction following the division sign.

- The **reciprocal** of $\frac{a}{b} = \frac{b}{a}$.

$$\frac{3x}{4} \div \frac{9}{8y} = \frac{3^1x}{4_1} \times \frac{8^2y}{9^3} = \frac{2xy}{3}$$

Exercise 9F

Understanding

1-3

3

1 Cancel to simplify these fractions.

a $\frac{4}{2}$

b $\frac{4x}{2}$

c $\frac{4(x+2)}{2}$

d $\frac{4(x-1)}{2}$

2 Write down the reciprocal of these fractions.

a $\frac{2}{3}$

b $\frac{4}{3}$

c $\frac{7x}{2}$

d $\frac{5}{4a^2}$

e 7

f $6x$

Hint:
Recall: $7 = \frac{7}{1}$ for part e.



3 Divide these simple fractions.

a $\frac{2}{3} \div \frac{3}{4}$

b $\frac{7}{8} \div \frac{3}{4}$

c $\frac{6}{7} \div \frac{4}{7}$

d $\frac{5}{14} \div \frac{10}{7}$

e $\frac{21}{4} \div \frac{7}{8}$

f $\frac{4}{9} \div \frac{4}{9}$

Hint:

- Copy the first fraction.
- Change the \div to \times .
- Flip over the second fraction.



Fluency

4-7(1/2)

4-7(1/2)



Example 13 Cancelling common factors

Simplify by cancelling common factors.

a $\frac{7x}{21}$

b $\frac{5(x+2)(x-1)}{x+2}$

Solution

a $\frac{\cancel{7}^1 x}{\cancel{21}_3} = \frac{x}{3}$

Explanation

The HCF of 7 and 21 is 7.

b $\frac{5\cancel{(x+2)}^1(x-1)}{\cancel{x+2}^1} = 5(x-1)$

Treat $(x+2)$ as a common factor to both the numerator and denominator.

Now you try

Simplify by cancelling common factors.

a $\frac{-2ab^2}{4b}$

b $\frac{-3(x-2)(x+7)}{3(x-2)}$

4 Simplify by cancelling common factors.

a $\frac{4x}{8}$

b $\frac{8x}{16}$

c $\frac{-4ab}{12}$

d $\frac{7a}{14b}$

e $\frac{4(x-1)}{4}$

f $\frac{-6(2x+1)}{3}$

g $\frac{-7x}{21x}$

h $\frac{4a^2}{40a}$

i $\frac{3(x+2)}{x+2}$

j $\frac{-2(x-7)}{x-7}$

k $\frac{5(x+3)}{10(x+3)}$

l $\frac{-16(x-14)}{24(x-14)}$

m $\frac{(x+2)(x-4)}{x+2}$

n $\frac{2(x-1)(x+3)}{x+3}$

o $\frac{-4(x+2)(x-5)}{2(x-5)}$

p $\frac{-7(x+1)(x-9)}{7(x+1)(x-9)}$

9F



Example 14 Simplifying by factorising

Simplify these fractions by factorising first.

a $\frac{2x+6}{2}$

b $\frac{-3x-9}{x+3}$

Solution

Explanation

$$\begin{aligned} \text{a } \frac{2x+6}{2} &= \frac{2^1(x+3)}{2^1} \\ &= x+3 \end{aligned}$$

First factorise the numerator, then cancel the 2.

$$\begin{aligned} \text{b } \frac{-3x-9}{x+3} &= \frac{-3(x+3)^1}{x+3^1} \\ &= -3 \end{aligned}$$

-3 is common to both -3x and -9. (x + 3) can now be cancelled.

Now you try

Simplify these fractions by factorising first.

a $\frac{5a-30}{5}$

b $\frac{-7x-14}{x+2}$

5 Simplify these fractions by factorising first.

a $\frac{4x+8}{4}$

b $\frac{2x-6}{2}$

c $\frac{3x-12}{3}$

d $\frac{3}{3x+3}$

e $\frac{-7}{14x+21}$

f $\frac{5a}{15a-10}$

g $\frac{2x+8}{x+4}$

h $\frac{7x+14}{x+2}$

i $\frac{-5x-15}{x+3}$

j $\frac{-4x-10}{2x+5}$

k $\frac{18+12x}{3+2x}$

l $\frac{-25-15x}{5+3x}$

Hint: First factorise the numerator or denominator, then cancel.



Example 15 Multiplying algebraic fractions

Simplify these products.

a $\frac{3x}{4} \times \frac{8}{9x}$

b $\frac{4(x+1)}{3} \times \frac{12}{x+1}$

Solution

Explanation

$$\begin{aligned} \text{a } \frac{3x^1}{4^1} \times \frac{8^2}{9x^3} &= \frac{1 \times 2}{1 \times 3} \\ &= \frac{2}{3} \end{aligned}$$

Cancel common factors from any numerator to any denominator, then multiply.

$$\begin{aligned} \text{b } \frac{4(x+1)^1}{3^1} \times \frac{12^4}{x+1^1} &= \frac{4 \times 4}{1 \times 1} \\ &= 16 \end{aligned}$$

Cancel all common factors before multiplying.

Now you try

Simplify these products.

a $\frac{2a^2}{3} \times \frac{9}{a}$

b $\frac{3x-1}{5} \times \frac{20}{6x-2}$

6 Simplify these products.

a $\frac{4x}{5} \times \frac{10}{8x}$

b $\frac{3x}{7} \times \frac{7}{6x}$

c $\frac{15a}{4} \times \frac{8}{25}$

d $\frac{16}{3a} \times \frac{9}{32}$

e $\frac{4y^2}{3} \times \frac{7x}{4y}$

f $\frac{8}{3x} \times \frac{5x^2}{16}$

g $\frac{2(x-1)}{3} \times \frac{6}{x-1}$

h $\frac{5(2x+1)}{4} \times \frac{4}{2x+1}$

i $\frac{3(x-7)}{7} \times \frac{21}{2(x-7)}$

j $\frac{x-3}{4} \times \frac{x+1}{x-3}$

k $\frac{3x+7}{x-2} \times \frac{x-2}{3x+7}$

l $\frac{5(x-2)}{3(x+7)} \times \frac{3(x+6)}{10(x-2)}$

Hint: Remember to cancel first before multiplying.

**Example 16 Dividing algebraic fractions**

Simplify the following.

a $\frac{3x}{4} \div \frac{6}{7}$

b $\frac{5(x+1)}{6} \div \frac{2(x+1)}{9}$

Solution

a
$$\frac{3x}{4} \div \frac{6}{7} = \frac{3^1 x}{4} \times \frac{7}{6^2}$$
$$= \frac{7x}{8}$$

b
$$\frac{5(x+1)}{6} \div \frac{2(x+1)}{9} = \frac{5(x+1)^1}{6^2} \times \frac{9^3}{2(x+1)^1}$$
$$= \frac{15}{4}$$

Explanation

Multiply by the reciprocal of the second fraction. Cancel before multiplying.

Invert the second fraction and multiply.

Cancel before multiplying.

Now you try

Simplify the following.

a $\frac{-2x}{3} \div \frac{4}{9}$

b $\frac{2}{3(4a-1)} \div \frac{5}{4a-1}$

7 Simplify the following.

a $\frac{2x}{3} \div \frac{4}{7}$

b $\frac{5x}{4} \div \frac{15}{8}$

c $\frac{-3a}{4} \div \frac{2a}{7}$

d $\frac{-6a}{7} \div \frac{12}{7a}$

e $\frac{4(x+1)}{3} \div \frac{2(x+1)}{9}$

f $\frac{2(x-1)}{5} \div \frac{3(x-1)}{10}$

g $\frac{11(x+4)}{x+1} \div \frac{x+4}{x+1}$

h $\frac{-3(2x-1)}{2x+1} \div \frac{2(2x-1)}{2x+1}$

i $\frac{-7(4x+3)}{2x-7} \div \frac{14(4x+3)}{2x-4}$

Hint: Multiply by the reciprocal of the fraction following the division sign.



Problem-solving and reasoning

8–9(½)

8–10(½)

8 Find the error in these problems and then find the correct answer.

a $\frac{2x+2^1}{2^1} = 2x+1$

b $\frac{-3x-6}{3} = \frac{-3(x-2)}{3}$

$= -(x-2)$

c $\frac{2x}{3} \div \frac{4x}{9} = \frac{8x^2}{27}$

d $\frac{x+2^1}{3^1} \times \frac{6^2x}{2^1} = 2x^2+1$

9 Simplify the following.

a $\frac{2x+4}{3} \times \frac{6}{x+2}$

b $\frac{5x-15}{7} \times \frac{7}{x-3}$

c $\frac{-6x-12}{x} \times \frac{3x}{x+2}$

d $\frac{5x-5}{2} \div \frac{x-1}{6}$

e $\frac{-17x-34}{x+1} \div \frac{x+2}{2x+2}$

f $\frac{-7x+14}{3x+2} \div \frac{2-x}{6x+4}$

Hint: Factorise expressions before cancelling; e.g. $2x+4$ can be written as $2(x+2)$.



10 We know that $\frac{a^2}{a}$ cancels to $\frac{a}{1} = a$. Similarly, $\frac{(x+1)^2}{x+1} = \frac{(x+1)\cancel{(x+1)}}{\cancel{x+1}} = x+1$. Use this idea to cancel the following.

a $\frac{(x+3)^2}{x+3}$

b $\frac{(2x-1)^2}{2x-1}$

c $\frac{-5(x-3)^2}{x-3}$

d $\frac{-2(x-4)}{6(x-4)^2}$



The negative 1 factor

—

11

11 Note that $3-2x = -1(2x-3)$. Use this idea to cancel the following.

a $\frac{3-2x}{2x-3}$

b $\frac{5-7x}{7x-5}$

c $\frac{4(2-x)}{3(x-2)}$

d $\frac{-2(x-5)}{5-x}$

e $\frac{2-x}{(x-2)^2}$

f $\frac{16(x-6)^2}{4(6-x)}$

9G Simplifying algebraic fractions: addition and subtraction

Learning intentions

- To know that the steps for adding and subtracting algebraic fractions are the same as for numerical fractions
- To be able to find the lowest common denominator of fractions
- To be able to add and subtract algebraic fractions

Key vocabulary: lowest common denominator, equivalent fraction, algebraic fraction, numerator, denominator

The process required for adding or subtracting algebraic fractions is similar to that used for fractions without pronumerals.

To simplify $\frac{2}{3} + \frac{4}{5}$, for example, you would find the lowest common multiple of the denominators (15) then express each fraction with this denominator. Adding the numerators completes the task.

Lesson starter: Compare the working

Here is the working for the simplification of the sum of a pair of numerical fractions and the sum of a pair of algebraic fractions.

$$\begin{aligned}\frac{2}{5} + \frac{3}{4} &= \frac{8}{20} + \frac{15}{20} \\ &= \frac{8+15}{20} \\ &= \frac{23}{20}\end{aligned}$$

$$\begin{aligned}\frac{2x}{5} + \frac{3x}{4} &= \frac{8x}{20} + \frac{15x}{20} \\ &= \frac{8x+15x}{20} \\ &= \frac{23x}{20}\end{aligned}$$

- What steps taken to simplify the algebraic fractions were the same as those used for the numerical fractions?
- Write down the steps required to add (or subtract) algebraic fractions.

Key ideas

- To add or subtract algebraic fractions:
 - determine the lowest common denominator (LCD)
 - express each fraction using the LCD
 - add or subtract the numerators.

$$\begin{aligned}\frac{2x}{3} - \frac{x}{5} &= \frac{10x}{15} - \frac{3x}{15} \\ &= \frac{10x-3x}{15} \\ &= \frac{7x}{15}\end{aligned}$$

Exercise 9G

Understanding

1–4

3, 4

1 Find the lowest common multiple (LCM) of these pairs of numbers.

a (6, 8)

b (3, 5)

c (11, 13)

d (12, 18)

2 Evaluate:

a $\frac{1}{2} + \frac{1}{3}$

b $\frac{3}{5} + \frac{1}{4}$

c $\frac{7}{8} + \frac{3}{4}$

d $\frac{9}{10} - \frac{1}{5}$

e $\frac{2}{3} - \frac{4}{5}$

f $\frac{11}{12} - \frac{5}{6}$

Hint: First find the LCM. Recall that the LCM of 8 and 4 is 8, not 32.



9G

3 Write equivalent fractions by stating the missing expression.

a $\frac{2x}{5} = \frac{\square}{10}$

b $\frac{7x}{3} = \frac{\square}{9}$

c $\frac{x+1}{4} = \frac{\square(x+1)}{12}$

d $\frac{3x+5}{11} = \frac{\square(3x+5)}{22}$

e $\frac{4}{x} = \frac{\square}{2x}$

f $\frac{30}{x+1} = \frac{\square}{3(x+1)}$

4 Copy and complete these simplifications.

a $\frac{x}{4} + \frac{2x}{3} = \frac{\square}{12} + \frac{\square}{12} = \frac{\square}{12}$

b $\frac{5x}{7} - \frac{2x}{5} = \frac{\square}{35} - \frac{\square}{35} = \frac{\square}{35}$

Hint: Remember to multiply the numerator by the same number that you multiplied the denominator.



Fluency

5, 6(½)

5, 6–7(½)

5 Write down the LCD for these pairs of fractions.

a $\frac{x}{3}, \frac{2x}{5}$

b $\frac{3x}{7}, \frac{x}{2}$

c $\frac{-5x}{4}, \frac{x}{8}$

d $\frac{2x}{3}, \frac{-5x}{6}$

e $\frac{7x}{10}, \frac{-3x}{5}$



Example 17 Adding and subtracting with a numeral in the denominator

Simplify:

a $\frac{7x}{3} + \frac{x}{6}$

b $\frac{x}{4} - \frac{2x}{5}$

Solution

$$\begin{aligned} \text{a } \frac{7x}{3} + \frac{x}{6} &= \frac{7x \times 2}{3 \times 2} + \frac{x}{6} \\ &= \frac{14x}{6} + \frac{x}{6} \\ &= \frac{14x + x}{6} \\ &= \frac{15x}{6} \\ &= \frac{5x}{2} \end{aligned}$$

$$\begin{aligned} \text{b } \frac{x}{4} - \frac{2x}{5} &= \frac{5x}{20} - \frac{8x}{20} \\ &= \frac{5x - 8x}{20} \\ &= -\frac{3x}{20} \end{aligned}$$

Explanation

Note that the LCM of 3 and 6 is 6, not $3 \times 6 = 18$.

For $\frac{7x}{3}$, multiply the numerator and denominator by 2. $\frac{x}{6}$ already has a denominator of 6. $\frac{15}{6} = \frac{5}{2}$ after cancelling.

Determine the LCM of 4 and 5; i.e. 20. Express each fraction as an equivalent fraction with a denominator of 20. $2x \times 4 = 8x$. Then subtract numerators.

Now you try

Simplify:

a $\frac{2a}{5} + \frac{3a}{10}$

b $\frac{7x}{8} - \frac{2x}{3}$

6 Simplify:

a $\frac{x}{7} + \frac{x}{2}$

b $\frac{x}{3} + \frac{x}{15}$

c $\frac{x}{4} - \frac{x}{8}$

d $\frac{x}{9} + \frac{x}{5}$

e $\frac{y}{7} - \frac{y}{8}$

f $\frac{a}{2} + \frac{a}{11}$

g $\frac{b}{3} - \frac{b}{9}$

h $\frac{m}{3} - \frac{m}{6}$

i $\frac{m}{6} + \frac{3m}{4}$

j $\frac{a}{4} + \frac{2a}{7}$

k $\frac{2x}{5} + \frac{x}{10}$

l $\frac{p}{9} - \frac{3p}{7}$

m $\frac{b}{2} - \frac{7b}{9}$

n $\frac{9y}{8} + \frac{2y}{5}$

o $\frac{4x}{7} - \frac{x}{5}$

p $\frac{3x}{4} - \frac{x}{3}$

Hint:

The LCM of 7 and 2 is 14, so

write $\frac{x}{7} + \frac{x}{2} = \frac{2x}{14} + \frac{7x}{14}$

$$= \frac{2x + 7x}{14}$$

$$= \frac{9x}{14}$$

**Example 18 Adding more algebraic fractions**Simplify: $\frac{x+3}{2} + \frac{x-2}{5}$ **Solution**

$$\begin{aligned} \frac{(x+3)}{2} + \frac{(x-2)}{5} &= \frac{5(x+3)}{10} + \frac{2(x-2)}{10} \\ &= \frac{5x+15+2x-4}{10} \\ &= \frac{7x+11}{10} \end{aligned}$$

Explanation

The LCM of 2 and 5 is 10. Write as equivalent fractions with denominator 10.
Expand the brackets and simplify the numerator by adding and collecting like terms.

Now you trySimplify: $\frac{x-3}{4} + \frac{x-2}{3}$

7 Simplify:

a $\frac{x+1}{2} + \frac{x+3}{5}$

b $\frac{x+3}{3} + \frac{x-4}{4}$

c $\frac{a-2}{7} + \frac{a-5}{8}$

d $\frac{y+4}{5} + \frac{y-3}{6}$

e $\frac{m-4}{8} + \frac{m+6}{5}$

f $\frac{x-2}{12} + \frac{x-3}{8}$

g $\frac{2b-3}{6} + \frac{b+2}{8}$

h $\frac{3x+8}{6} + \frac{2x-4}{3}$

i $\frac{2y-5}{7} + \frac{3y+2}{14}$

j $\frac{2t-1}{8} + \frac{t-2}{16}$

k $\frac{4-x}{3} + \frac{2-x}{7}$

l $\frac{2m-1}{4} + \frac{m-3}{6}$

Hint: Remember to include brackets when multiplying a numeral by these binomial numerators.

**Problem-solving and reasoning**

8, 9

9–11

8 A student thinks that the LCD to use when simplifying $\frac{x}{2} + \frac{3x}{4}$ is 8.

a Complete the simplification using a common denominator of 8.

b Now complete the simplification using the actual LCD of 4.

c How does your working for parts a and b compare? Which method is preferable and why?

9G

9 Find and describe the error in each set of working. Then give the correct answer.

a $\frac{4x}{5} - \frac{x}{3} = \frac{3x}{2}$

b $\frac{x+1}{5} + \frac{x}{2} = \frac{2x+1}{10} + \frac{5x}{10}$
 $= \frac{7x+1}{10}$

10 Simplify:

a $\frac{3}{x} + \frac{5}{2x}$

b $\frac{7}{3x} - \frac{2}{x}$

c $\frac{7}{4x} - \frac{5}{2x}$

d $\frac{4}{3x} + \frac{2}{9x}$

Hint: Your common denominator will contain x .
The LCM of x and $2x$ is $2x$.



11 Simplify by first finding the LCD:

a $\frac{2x}{5} - \frac{3x}{2} - \frac{x}{3}$

b $\frac{x}{4} - \frac{2x}{3} + \frac{5x}{6}$

c $\frac{5x}{8} - \frac{5x}{6} + \frac{3x}{4}$

d $\frac{x+1}{4} + \frac{2x-1}{3} - \frac{x}{5}$

e $\frac{2x-1}{3} - \frac{2x}{7} + \frac{x-3}{6}$

f $\frac{1-2x}{5} - \frac{3x}{8} + \frac{3x+1}{2}$

Hint: Choose a common denominator that works for all three fractions.



The missing algebraic fractions

—

12

12 Find the missing algebraic fraction. The fraction should be in simplest form.

a $\frac{x}{2} + \frac{\square}{\square} = \frac{5x}{6}$

b $\frac{\square}{\square} + \frac{x}{4} = \frac{3x}{8}$

c $\frac{2x}{5} + \frac{\square}{\square} = \frac{9x}{10}$

d $\frac{2x}{3} - \frac{\square}{\square} = \frac{7x}{15}$

e $\frac{\square}{\square} - \frac{x}{3} = \frac{5x}{9}$

f $\frac{2x}{3} - \frac{\square}{\square} = \frac{5x}{12}$



Maths@Work: Automotive technology

The automotive industry is now more technically complex with the increased use of computer technology in cars. Training for automotive trades requires students to have mechanical ability as well as problem-solving and mathematical skills.

The machinists and technicians constructing and installing parts must have an eye for detail and excellent measurement skills.

Formulas are widely used in all trades to calculate quantities such as area, volume and maximum loads and friction. The universal tool for simplifying such formulas is algebra.



1 Write the algebraic formula for the total surface area (TSA) of each solid below using the given pronumerals. Simplify each formula by taking out any common factors.

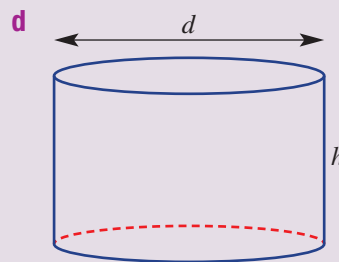
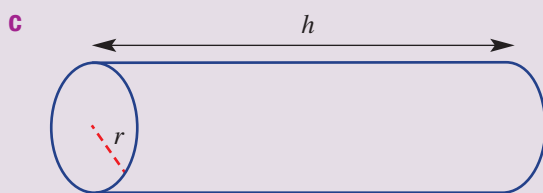
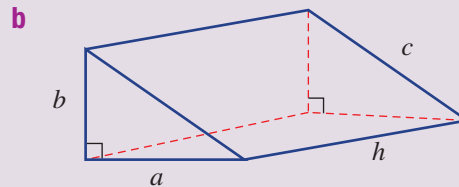
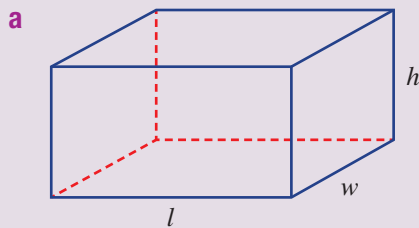

2 Match each of the following volume formulae to one of the solids shown in Question 1.

- i** $V = \pi r^2 h$
- ii** $V = lwh$
- iii** $V = \frac{1}{2}abh$
- iv** $V = \frac{\pi d^2 h}{4}$

- 3 The cross-sectional area of a pipe is used when calculating the weight of a given length of pipe. To simplify the area formula, the algebraic difference of perfect squares (DOPS) rule is used.

a Copy and complete this procedure.

$$\begin{aligned}
 \text{Area of cross-section} &= \pi R^2 - \square \\
 &= \pi(\square - r^2) \\
 &= \pi\left(\frac{\square}{2^2} - \frac{d^2}{2^2}\right) \\
 &= \frac{\pi}{4}(D^2 - \square) \\
 &= \frac{\pi}{4}(D + d)(\square - \square)
 \end{aligned}$$

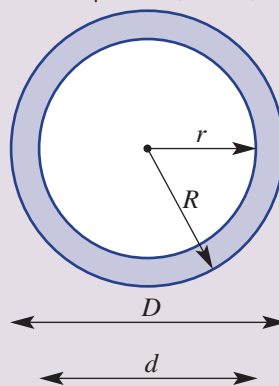

- b Use the above formula to calculate the exact area of cross-section, as a multiple of π , given the following diameters of various pipes.

- i $D = 40$ mm and $d = 36$ mm
- ii $D = 32$ mm and $d = 30$ mm
- iii $D = 2.7$ cm and $d = 2.3$ cm
- iv $D = 6.5$ cm and $r = 5.5$ cm

Using technology

- 4 The approximate weight of a length of pipe can be determined by this formula:

$$\begin{aligned}
 \text{weight} &= \text{cross-section area (cm}^2\text{)} \times \text{length (cm)} \\
 &\quad \times \text{density (g/cm}^3\text{)}
 \end{aligned}$$

Develop the Excel spreadsheet shown below to calculate the weights of various lengths of pipe. Enter appropriate formulas into the shaded cells.

	A	B	C	D	E	F	G	H
1	Weight of pipe lengths							
2						100		
3	Pipe material	Outer diameter in cm	Inner diameter in cm	Area of cross-section in cm ²	Density in g/cm ³	Length in cm	Weight in g	Weight in kg
4	Poly pipe a	4.3	3.7		0.955			
5	Poly pipe b	12.5	11.9		0.955			
6	Poly pipe c	31.5	28.5		0.955			
7	Copper pipe a	1.2	1		8.94			
8	Copper pipe b	2	1.9		8.94			
9	Copper pipe c	5	4.8		8.94			
10	Steel pipe a	4.8	4.4		7.85			
11	Steel pipe b	6	5		7.85			
12	Steel pipe c	16.5	15.5		7.85			

Hint: When entering the formula for cross-sectional area use $\text{pi}()$ for π . Link all the length cells' formulae to cell F2 by using \$ signs, i.e. = \$F\$2. Format area and weight cells to 'number' with two decimal places.



- a Find the difference in kg/m between copper pipe c and steel pipe b.
- b Find the difference in weight between 3.5 m of poly pipe a and 3.5 m of steel pipe a.
- c Find the difference in weight between 2.75 m of poly pipe c and 5 m of steel pipe c.

Square castle moats

Moats were constructed around castles to help protect its occupants from invaders. A square castle of side length 40 metres is to be surrounded by a square moat of a certain width as shown.

Present a report for the following tasks and ensure that you show clear mathematical workings, explanations and diagrams where appropriate.

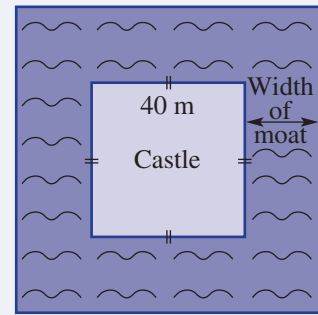

Preliminary task

- Find the area of land occupied by the square castle of side 40-metres.
- If the width of the moat is 10 metres, find the surface area of the water in the moat.
- Find the outside perimeter of the moat if the width of the moat is 8.5 metres.

Modelling task

The problem is to determine a width for the moat so that the surface area of water is at least 10 times the area of the castle.

- Write down all the relevant information that will help solve this problem with the aid of a diagram.
- If the width of the moat is x metres, find expressions in terms of x for the following:
 - the perimeter of the outside of the moat
 - the total area occupied by the moat and the castle.

- Use your expressions from part **b** to show that the area occupied by the moat, not including the castle, can be written in the form $4x(40 + x)$.
- Using the expression from part **c**, find the area occupied by the moat for the following values of x .
 - 10
 - 40
 - 50
- For each value of x in part **d**, calculate the value of $\frac{\text{Moat area}}{\text{Castle area}}$.
- Using trial and error, determine the **smallest integer** value of x such that the area of the moat is at least 10 times the area of the castle.

- Assuming that the lord of the castle wants the area of the moat to be as close as possible to 10 times the area of the castle, investigate if this is possible using non-integer values of x to one decimal place.

- Summarise your results using a table like the one below and describe any key findings.

Moat width x metres					
Area of moat in m^2					
Area of castle in m^2					
$\frac{\text{Moat area}}{\text{Castle area}}$					

Extension questions

- a** Instead, the lord wants to build a square castle of side length x metres inside a square lake of side length 50 metres.
- Draw a labelled diagram showing the square castle within the square moat.
 - Show that the remaining lake area forming the moat is given by the expression $(50 + x)(50 - x)$.
 - Calculate the value of $\frac{\text{Moat area}}{\text{Castle area}}$ to one decimal place, when:
 - $x = 13$
 - $x = 17$
 - Determine the smallest integer width of the castle that delivers a moat area which is at least 10 times the area of the castle.



1 'You use me when dividing fractions.' Simplify each expression, then match the answers to the letters to solve the riddle.

P	L	C	R						
$-2x \times 3x$	$(x+1)(x-1)$	$\frac{2x-6}{2}$	$\frac{5x^2}{10x}$						
O	A	E	I						
$\frac{x}{2} - \frac{x}{3}$	$\frac{x+3}{2} \times \frac{6}{x+3}$	$\frac{2x}{3} \div \frac{4}{9}$	$7ab - 6ba$						
<input type="checkbox"/>	<input type="checkbox"/>	<input type="checkbox"/>	<input type="checkbox"/>	<input type="checkbox"/>	<input type="checkbox"/>	<input type="checkbox"/>	<input type="checkbox"/>	<input type="checkbox"/>	<input type="checkbox"/>
$\frac{x}{2}$	$\frac{3x}{2}$	$x-3$	ab	$-6x^2$	$\frac{x}{2}$	$\frac{x}{6}$	$x-3$	3	x^2-1

2 A square framed photograph has side length 20 cm and frame width x cm.

- a Find an expanded expression for the area of the picture.
- b What value of x makes the picture $\frac{1}{4}$ of the total area?

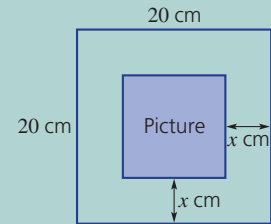

3 Write an expression that gives the total number of dots required for the n th diagram.

a		b	
$n=1$	$n=2$	$n=1$	$n=2$
$n=1$	$n=2$	$n=3$	$n=3$

4 Simplify these algebraic fractions. Don't be fooled by the double negative.

a $\frac{x+1}{3} - \frac{x-2}{4}$ b $\frac{3x-4}{5} - \frac{4x-2}{3}$

- 5 a The difference between the squares of two consecutive numbers is 97. What are the two numbers?
 - b The difference between the squares of two consecutive odd numbers is 136. What are the two numbers?
 - c The difference between the squares of two consecutive multiples of 3 is 81. What are the two numbers?
- 6 In a race over 4 km, Ryan ran at a constant speed. Sophie ran the first 2 km at a speed 1 km/h faster than Ryan. She ran the second 2 km at a speed 1 km/h slower than Ryan. Who won the race?

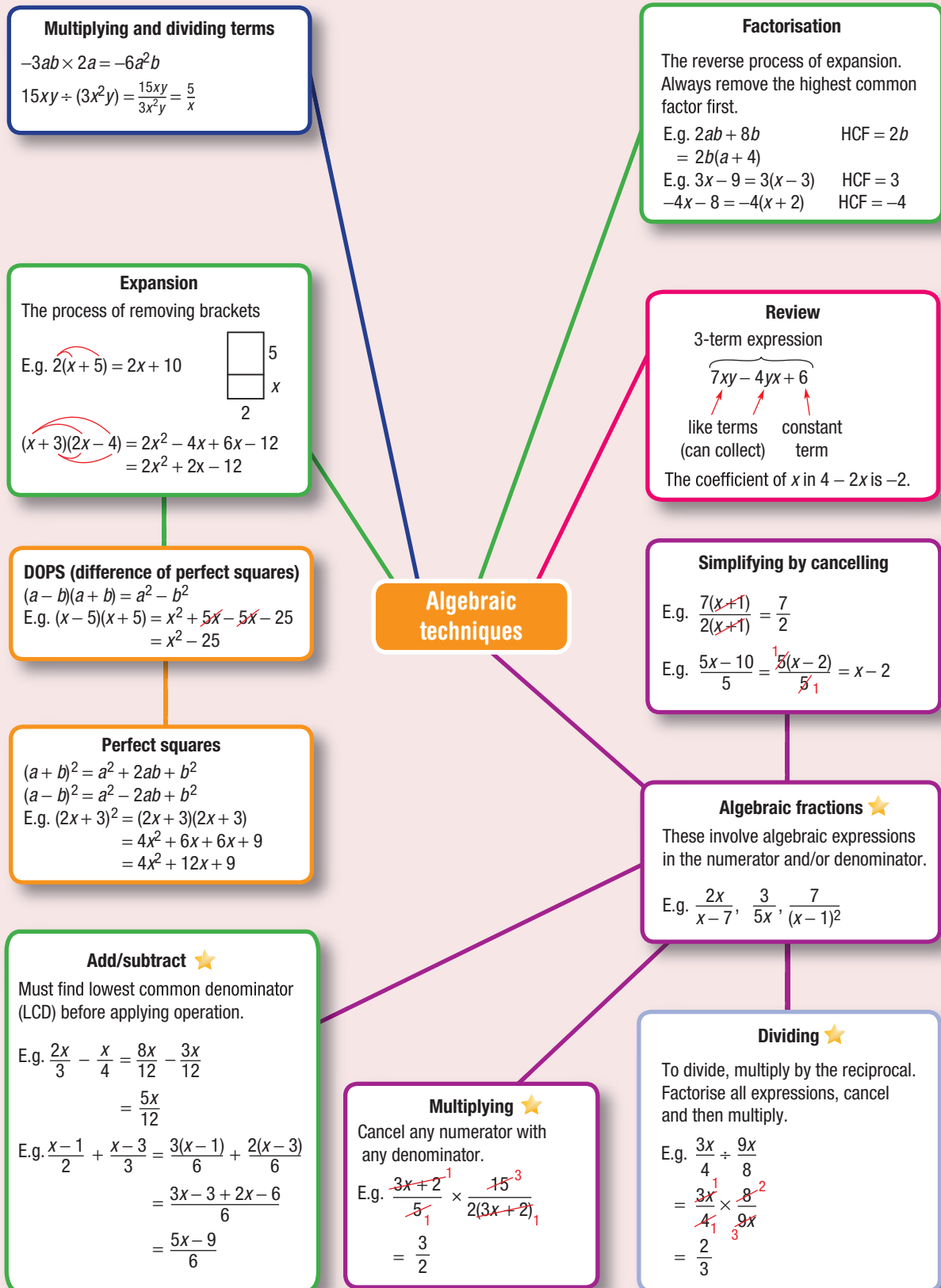



Chapter checklist

A version of this checklist that you can print out and complete can be downloaded from your Interactive Textbook.

9A	1 I can identify and collect like terms. e.g. Simplify: a $4a^2 - ab - 2a^2 + 1$ b $5x^2y - xy - 6yx^2$	✓
9A	2 I can evaluate an algebraic expression using substitution. e.g. If $x = 2$ and $y = -5$, evaluate $y^2 - xy$.	
9A	3 I can multiply and divide algebraic terms. e.g. Simplify: a $2ab \times 7a$ b $8xy \div (24x)$	
9A	4 I can expand expressions with brackets. e.g. Expand the following: a $-3(x - 2)$ b $-2a(4a - 5)$	
9B	5 I can expand binomial products. e.g. Expand: a $(x - 3)(2x + 5)$ b $(3x - 7)(2x - 5)$	
9C	6 I can expand perfect squares. e.g. Expand: a $(x + 7)^2$ b $(4x - 3)^2$	
9D	7 I can expand to form a difference of perfect squares. e.g. Expand: a $(x - 4)(x + 4)$ b $(3x + 5)(3x - 5)$	
9E	8 I can determine the HCF. e.g. Determine the HCF of the terms $6xy$ and $18xy^2$.	
9E	9 I can factorise expressions with common factors. e.g. Factorise the following: a $5a + 15$ b $11x^2 - 33xy$ c $-14mn - 7m$ (including common negative)	
9F	10 I can simplify algebraic fractions. e.g. Simplify this fraction by factorising first: $\frac{2x - 4}{x - 2}$.	
9F	11 I can multiply algebraic fractions. e.g. Simplify $\frac{x + 3}{6} \times \frac{9}{x + 3}$.	
9F	12 I can divide algebraic fractions. e.g. Simplify $\frac{5(x + 2)}{8} \div \frac{10(x + 2)}{4}$.	
9G	13 I can add and subtract simple algebraic fractions. e.g. Simplify: a $\frac{2x}{5} - \frac{3x}{10}$ b $\frac{x - 3}{4} + \frac{2x - 5}{3}$	

Short-answer questions

- 9A 1** Simplify these expressions.
a $3x \times 2x$ **b** $-3ab \times 6b$ **c** $7ab \div (14a)$ **d** $-40x^2y \div (10xy)$
- 9A 2** Expand the following.
a $3(x-4)$ **b** $-2(x+6)$ **c** $-x(x-1)$ **d** $-4x(2x-3)$
- 9A 3** Collect like terms to simplify.
a $5x-1+2x$ **b** $7ab-2ba$ **c** $4a^2b-7a^2b$ **d** $5x^2-xy+3x^2$
- 9B 4** Expand the following binomial products.
a $(x-3)(x+4)$ **b** $(x-7)(x-2)$ **c** $(2x-3)(3x+2)$ **d** $(x-1)(3x+4)$
- 9C/9D 5** Expand the following.
a $(x+3)^2$ **b** $(x-4)^2$ **c** $(3x-2)^2$
d $(x-5)(x+5)$ **e** $(7-x)(7+x)$ **f** $(11x-4)(11x+4)$
- 9E 6** Write the following in fully factorised form by removing the highest common factor.
a $4a+12b$ **b** $-3-9x$ **c** x^2+x
d $6x-9x^2$ **e** $-5x^2y-10xy$ **f** $11a^2b-33ab$
- 9F 7** Simplify the following.
a $\frac{3(x-1)}{6}$ **b** $\frac{(x+1)(x-3)}{x-3}$ **c** $\frac{3x+12}{3}$
 **d** $\frac{-5x-15}{10}$ **e** $\frac{2x-16}{3x-24}$ **f** $\frac{2(x+2)(x-1)}{x+2}$
- 9F 8** Simplify the following algebraic fractions by first factorising and cancelling where possible.
a $\frac{3}{2x} \times \frac{x}{6}$ **b** $\frac{7a^2}{x+1} \times \frac{x+1}{14a}$ **c** $\frac{x(x-4)}{8(x+1)} \times \frac{4(x+1)}{x}$
 **d** $\frac{3a}{5} \div \frac{9}{10}$ **e** $\frac{2(x-1)}{3} \div \frac{x-1}{6}$ **f** $\frac{2x}{5x+20} \div \frac{x}{x+4}$
- 9G 9** Simplify the following by first finding the lowest common denominator.
a $\frac{x}{4} + \frac{2x}{3}$ **b** $\frac{5x}{6} - \frac{7x}{8}$ **c** $\frac{3a}{4} - \frac{a}{2}$
 **d** $\frac{x}{2} + \frac{x-1}{3}$ **e** $\frac{2x-3}{4} + \frac{x+1}{3}$ **f** $\frac{x-1}{6} + \frac{x+3}{8}$

Multiple-choice questions

- 9A 1** The constant term in the expression $2x^2 - 3$ is:
A 3 **B** 2 **C** -2 **D** $2x^2$ **E** -3
- 9A 2** The expanded form of $-2(x+3)$ is:
A $2x+6$ **B** $-2x-3$ **C** $-2x-6$ **D** $-2x+6$ **E** $-2x+3$
- 9A 3** $x^2 - 2xy + 2yx$ is equal to:
A xy **B** x^2 **C** $x^2 - 4xy$ **D** 0 **E** $4xy$
- 9A 4** $-3ab \times 4b$ is equal to:
A $-7ab^2$ **B** $-12ab^2$ **C** $-7a^2b$ **D** $-12a^2b$ **E** $12ab^2$
- 9B 5** $(x-3)(x-4)$ expands to:
A 12 **B** x^2+12 **C** $x^2-7x+12$ **D** x^2-x-12 **E** $x^2+7x-12$

- 9B** **6** $(2x - 1)(x + 5)$ in expanded and simplified form is:
A $2x^2 + 9x - 5$ **B** $x^2 + 11x - 5$ **C** $4x^2 - 5$ **D** $3x^2 - 2x + 5$ **E** $2x^2 + 4x - 5$
- 9C** **7** $(3a + 2b)^2$ is equivalent to:
A $9a^2 + 6ab + 4b^2$ **B** $9a^2 + 4b^2$ **C** $3a^2 + 6ab + 2b^2$
D $3a^2 + 12ab + 2b^2$ **E** $9a^2 + 12ab + 4b^2$
- 9F** **8** $\frac{5x}{3} \div \frac{15x}{12}$ is equal to:
A $\frac{4}{3}$ **B** $\frac{4x}{3}$ **C** $\frac{4}{3x}$ **D** $\frac{25x^2}{12}$ **E** $\frac{25x}{12}$
- 9G** **9** $\frac{4x}{3} - \frac{2x}{9}$ is equal to:
A $\frac{10x}{27}$ **B** $\frac{30x}{9}$ **C** $\frac{2x}{9}$ **D** $\frac{2x}{3}$ **E** $\frac{10x}{9}$
- 9G** **10** $\frac{x+2}{5} + \frac{2x-1}{3}$ written as a single fraction is:
A $\frac{11x+1}{15}$ **B** $\frac{11x+9}{8}$ **C** $\frac{3x+1}{8}$ **D** $\frac{11x+7}{15}$ **E** $\frac{13x+1}{15}$

Extended-response questions

- 1** A pig pen for a small farm is being redesigned. It is originally a square of side length x m.
- In the planning, the length is initially kept as x m. The width is altered such that the area of the pen is $(x^2 + 3x)$ square metres. What is the new width? (Consider factorising.)
 - Instead, it is decided that the original length will be increased by 1 metre and the original width will be decreased by 1 metre.
 - What effect does this have on the perimeter of the pig pen compared with the original size?
 - Work out an expression for the new area of the pig pen in expanded form. How does this compare to the original area?
 - For the pig pen described in part **b**:
 - what would be the area if $x = 2$?
 - what value of x gives an area of 15 m^2 ? Use trial and error.
- 2** The security tower for a palace is on a small square piece of land 20 m by 20 m. It has a moat of width x metres the whole way around it, as shown.
- State the area of the piece of land.
 - Give an expression for the side length of the combined moat and land.
 - Find an expression, in expanded form, for the entire area occupied by the moat and the land.
 - Use your answers to parts **a** and **b** to give an expression for the area occupied by the moat alone. Answer in factorised form.
 - Use trial and error to find the value of x such that the area of the moat alone is 500 m^2 .

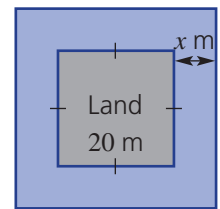
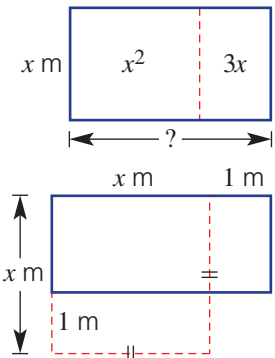

Chapter 10

Statistics and probability

Essential mathematics: why skills in statistics and probability are important

Statistical measures, displays and probabilities are essential for making sense of huge amounts of data. Statistics and probability are widely used for planning, including by farmers, sports clubs, businesses, medical researchers, governments, insurance and marketing agents.

- Weather forecast probabilities of rain, storms, wind strengths, temperatures, fires, floods and droughts are important for planning by emergency services, air traffic control, farmers and holiday makers.
- Venn diagrams and arrays help analyse data, such as for the number of people who smoke, die of cancer or both; and the number of vehicle accidents caused by speed, alcohol or both.
- Car insurance premiums are based on past proportions of accidents with drivers of various ages. Hence car insurance is a lot more expensive for car owners aged under 25.



In this chapter

- 10A Review of probability (**Consolidating**)
- 10B Venn diagrams and two-way tables
- 10C Using arrays for two-step experiments
- 10D Tree diagrams
- 10E Experimental probability
- 10F Summarising data: range and measures of centre
- 10G Interpreting data from tables and graphs
- 10H Stem-and-leaf plots
- 10I Grouped data

Australian Curriculum

STATISTICS AND PROBABILITY

Chance

List all outcomes for two-step chance experiments, both with and without replacement using tree diagrams or arrays. Assign probabilities to outcomes and determine probabilities for events (ACMSP225)

Calculate relative frequencies from given or collected data to estimate probabilities of events involving 'and' or 'or' (ACMSP226)

Investigate reports of surveys in digital media and elsewhere for information on how data were obtained to estimate population means and medians (ACMSP227)

Data representation and interpretation

Identify everyday questions and issues involving at least one numerical and at least one categorical variable, and collect data directly and from secondary sources (ACMSP228)

Construct back-to-back stem-and-leaf plots and histograms and describe data, using terms including 'skewed', 'symmetric' and 'bi-modal' (ACMSP282)

Compare data displays using mean, median and range to describe and interpret numerical data sets in terms of location (centre) and spread (ACMSP283)

© Australian Curriculum, Assessment and Reporting Authority (ACARA)

Online resources

A host of additional online resources are included as part of your Interactive Textbook, including HOTmaths content, video demonstrations of all worked examples, auto-marked quizzes and much more.

1 Write as decimals:

a $\frac{1}{10}$

b $\frac{2}{8}$

c 30%

d 85%

e 23.7%

2 Express in simplest form:

a $\frac{4}{8}$

b $\frac{7}{21}$

c $\frac{20}{30}$

d $\frac{100}{100}$

e $\frac{0}{4}$

f $\frac{12}{144}$

g $\frac{36}{72}$

h $\frac{36}{58}$

i $\frac{72}{108}$

j $\frac{2}{7}$

3 A six-sided die is tossed.

a List the possible outcomes.

b How many of the outcomes are:

i even?

ii less than 3?

iii less than or equal to 3?

iv at least 2?

v not a 6?

vi not odd?

4 From the group of the first 10 integers $\{1, 2, \dots, 10\}$, how many of the numbers are:

a odd?

b less than 8?

c greater than or equal to 5?

d no more than 7?

e prime?

f not prime?

5 Several cards were randomly selected from a pack of playing cards. The suit of each card was noted, the card was replaced and the pack was shuffled. The frequency of each suit is shown in the column graph.

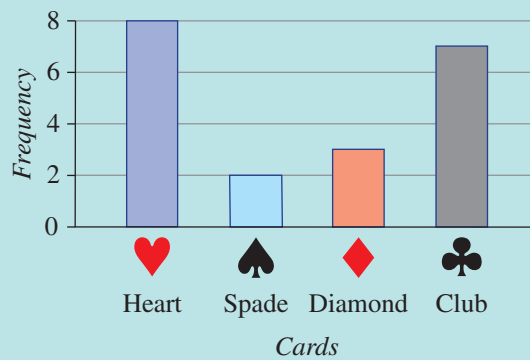

a How many times was a heart selected?

b How many times was a card selected in total?

c In what fraction of the trials was a diamond selected?

6 Consider this simple data set: 1, 2, 3, 5, 5, 7, 8, 10, 13.

a State the number of scores, n .

b Find the mean (the sum of scores divided by n).

c Find the median (the middle value).

d Find the mode (the most common value).

e Find the range (the difference between the highest and lowest value).

f Find the probability of randomly selecting:

i a 5

ii a number that is not 5

iii a number that is no more than 5

10A Review of probability

CONSOLIDATING

Learning intentions

- To understand the concept of chance and how to describe it numerically
- To be able to interpret the language of probability
- To be able to find the probability of an event for equally likely outcomes

Key vocabulary: probability, experiment, sample space, outcome, event, complement, chance

The mathematics used to calculate chance is called probability. We use it to compare the number of favourable outcomes to the total number of outcomes. This shows us how likely it is that the favourable event will occur. The probability of an event occurring is a number between 0 and 1. An impossible event has a probability of 0. An event that is certain to occur has a probability of 1.

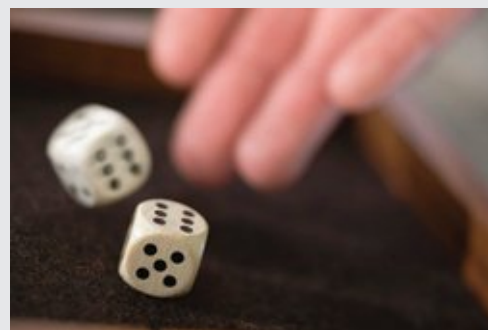

We can use probability to find the likelihood of rolling a particular total score with two dice.

→ Lesson starter: Events and probabilities

As a class group, write down and discuss at least three events that have the following chance of occurring.

- impossible chance
- very low chance
- medium to low chance
- even (50 : 50) chance
- medium to high chance
- very high chance
- certain chance

For each decimal marked on the number line below, choose the probability description from the list above that best matches it.

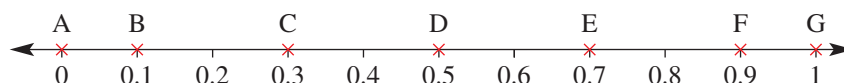

Key ideas

- A random **experiment** has various possible **outcomes** that occur without interference.
- An outcome is a possible result from a **chance** experiment.
- The **sample space** is the list of all possible outcomes of an experiment.
- An **event** is a collection of outcomes resulting from an experiment.
For example, rolling a die is a random experiment with six possible outcomes: 1, 2, 3, 4, 5 and 6.
The event 'rolling a number greater than 4' includes the outcomes 5 and 6.
The event 'rolling a number at least 4' includes the outcomes 4, 5 and 6.
- **Probability** is a measure of the likelihood that an event will occur.
- The probability of an event where all outcomes are equally likely is given by:

$$\text{Pr}(\text{Event}) = \frac{\text{Number of outcomes where event occurs}}{\text{Total number of outcomes}}$$
- Probabilities are numbers between 0 and 1 and can be written as a decimal, fraction or percentage.
For example: 0.55 or $\frac{11}{20}$ or 55%

10A

- For all events, $0 \leq \text{Pr}(\text{Event}) \leq 1$.

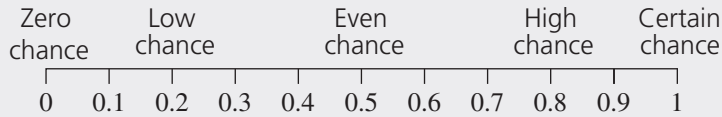

- The **complement** of event A is written A' (or not A). A' is the event that A does not occur.
 $\text{Pr}(A') = 1 - \text{Pr}(A)$ or $\text{Pr}(\text{not } A) = 1 - \text{Pr}(A)$

Exercise 10A

Understanding

1-4

3,4

- Write the missing words in each statement.
 - The _____ is the list of all possible outcomes in an experiment.
 - An _____ is a collection of the outcomes from an experiment.
 - Pr stands for _____.
 - An _____ event has a probability of 0, an event that is _____ to occur has a probability of 1.
 - An event with probability of 0.5 has _____ or 50 : 50 chance of occurring.
 - The _____ of an event, A, is the event where A does not occur.

- Jim believes that there is a 1 in 4 chance that the flower on his prized rose will bloom tomorrow.

- Write the chance '1 in 4' as:
 - a fraction
 - a decimal
 - a percentage
- Draw a number line from 0 to 1 and mark the level of chance described by Jim.

Hint: '1 in 4' means $\frac{1}{4}$.



Hint: Percentage $\div 100 =$ decimal



- Copy and complete this table.

	Percentage	Decimal	Fraction	Number line
a	50%	0.5	$\frac{1}{2}$	
b	25%			
c			$\frac{3}{4}$	
d				

- Ten people make the following guesses of the chance that they will get a salary bonus this year.

$0.7, \frac{2}{5}, 0.9, \frac{1}{3}, 2 \text{ in } 3, \frac{3}{7}, 1 \text{ in } 4, 0.28, \frac{2}{9}, 0.15$

Order their chances from lowest to highest.

Hint: First write each chance as a decimal.



Fluency

5(½), 6–9

5–7(½), 8, 9(½)



Example 1 Finding probabilities of events

This spinner has five equally divided sections.

- List the sample space using the different numbers.
- Find $\Pr(3)$.
- Find $\Pr(\text{not a } 3)$.
- Find $\Pr(\text{a } 3 \text{ or a } 7)$.
- Find $\Pr(\text{a number that is at least a } 3)$.

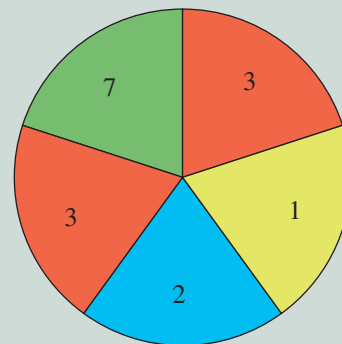

Solution

a $\{1, 2, 3, 7\}$

Explanation

Use set brackets, $\{\}$, and list all the possible outcomes in any order.

b $\Pr(3) = \frac{2}{5}$ or 0.4

$$\Pr(3) = \frac{\text{number of sections labelled } 3}{\text{number of equal sections}}$$

c $\Pr(\text{not a } 3) = 1 - \Pr(3)$
 $= 1 - \frac{2}{5}$ or $1 - 0.4$
 $= \frac{3}{5}$ or 0.6

'Not a 3' is the complementary event of obtaining a 3.

Alternatively, count the number of sectors that are not 3.

d $\Pr(\text{a } 3 \text{ or a } 7) = \frac{2}{5} + \frac{1}{5}$
 $= \frac{3}{5}$

There are two 3s and one 7 in the five sections.

e $\Pr(\text{at least a } 3) = \frac{3}{5}$

Three of the sections have the numbers 3 or 7, which are at least 3; i.e. 3 or more.

Now you try

This spinner has six equally divided sections.

- List the sample space using the different numbers.
- Find $\Pr(2)$.
- Find $\Pr(\text{not a } 1)$.
- Find $\Pr(\text{a } 2 \text{ or a } 3)$.
- Find $\Pr(\text{a number which is at most } 2)$.

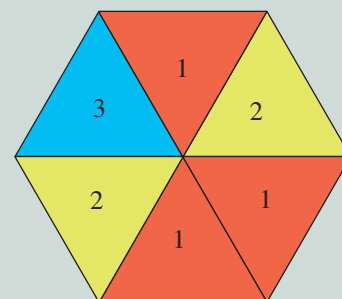

10A

5 The spinners below have equally divided sections. Complete the following for each spinner. Write all probabilities as simplified fractions.

- i List the sample space using the given numbers.
- ii Find $\text{Pr}(2)$.
- iii Find $\text{Pr}(\text{not a } 2)$.
- iv Find $\text{Pr}(\text{a } 2 \text{ or a } 3)$.
- v Find $\text{Pr}(\text{a number which is at least a } 2)$.

Hint: $\text{Pr}(\text{event})$ means 'find the probability of the event'. 'At least 2' means '2 or more'.



a



b

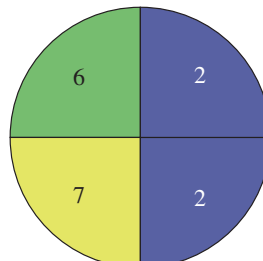

c

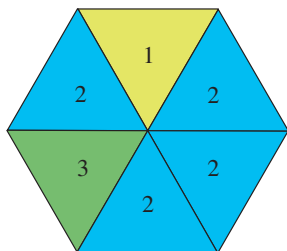

d

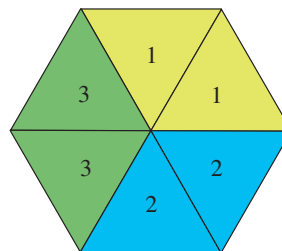

e

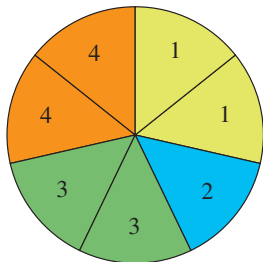

f

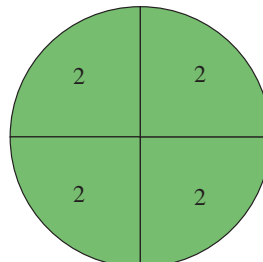

6 Find the probability of obtaining a blue ball if a ball is selected at random from a box that contains:

- a 4 blue balls and 4 red balls
- b 3 blue balls and 5 red balls
- c 1 blue ball, 3 red balls and 2 white balls
- d 8 blue balls, 15 black balls and 9 green balls
- e 15 blue balls only
- f 5 yellow balls and 2 green balls

Hint: $\text{Pr}(\text{blue}) = \frac{\text{number of blue balls}}{\text{total number of balls}}$



7 Find the probability of *not* selecting a blue ball if a ball is selected at random from a box containing the balls described in Question 6, parts a to f, above.

Hint: $\text{Pr}(\text{not blue}) = 1 - \text{Pr}(\text{blue})$



8 If a swimming pool has eight lanes and each of eight swimmers has an equal chance of being placed in lane 1, find the probability that a particular swimmer:

- a will swim in lane 1
- b will not swim in lane 1



Example 2 Choosing letters from a word

A letter is randomly chosen from the word PROBABILITY. Find the following probabilities.

- | | |
|---------------------------|---------------------------------|
| a Pr(L) | b Pr(not L) |
| c Pr(vowel) | d Pr(consonant) |
| e Pr(vowel or a B) | f Pr(vowel or consonant) |

Solution

Explanation

- | | |
|---|---|
| a $\Pr(L) = \frac{1}{11}$ | One of the 11 letters is an L. |
| b $\Pr(\text{not } L) = 1 - \frac{1}{11}$
$= \frac{10}{11}$ | The event 'not L' is the complement of the event selecting an L. Complementary events sum to 1. $\Pr(\text{not } L) = 1 - \Pr(L)$. |
| c $\Pr(\text{vowel}) = \frac{4}{11}$ | The vowels of the alphabet are A, E, I, O and U. There are 4 vowels in PROBABILITY: O, A and two letter Is. |
| d $\Pr(\text{consonant}) = 1 - \frac{4}{11}$
$= \frac{7}{11}$ | The events 'vowel' and 'consonant' are complementary.
Alternatively, the other 7 letters are consonants; thus $\frac{7}{11}$. |
| e $\Pr(\text{vowel or a B}) = \frac{6}{11}$ | There are 4 vowels and 2 letter Bs. |
| f $\Pr(\text{vowel or consonant}) = 1$ | This event includes all possible outcomes, since a letter is either a vowel or a consonant. |

Now you try

A letter is chosen from the word EXPERIMENT. Find the following probabilities.

- | | |
|-----------------------------|---|
| a Pr(M) | b Pr(not an E) |
| c Pr(vowel) | d Pr(consonant) |
| e Pr(E or consonant) | f Pr(letter from the first half of the alphabet) |

9 A letter is chosen at random from the word ALPHABET. Find the following probabilities.

- | | |
|------------------------|---|
| a Pr(L) | b Pr(A) |
| c Pr(A or L) | d Pr(vowel) |
| e Pr(consonant) | f Pr(vowel or consonant) |
| g Pr(Z) | h Pr(A or Z) |
| i Pr(not an A) | j Pr(letter from the first half of the alphabet) |

Hint: Recall that vowels are A, E, I, O and U.



Problem-solving and reasoning

10, 11

11–13

- 10 The school captain is to be chosen at random from four candidates. Two are girls (Hayley and Alisa) and two are boys (Rocco and Stuart).

- a List the sample space.
 b Find the probability that the school captain will be:
 i Hayley
 ii male
 iii neither Stuart nor Alisa

Hint: The sample space is a list of the possible students.



- 11 A card is drawn at random from a pack of 52 playing cards. Find the probability that the selected card will be:

- a the queen of diamonds b an ace
 c a red king d a red card
 e a jack or a queen f any card except a 2
 g any card except a jack or a black queen h not a black ace

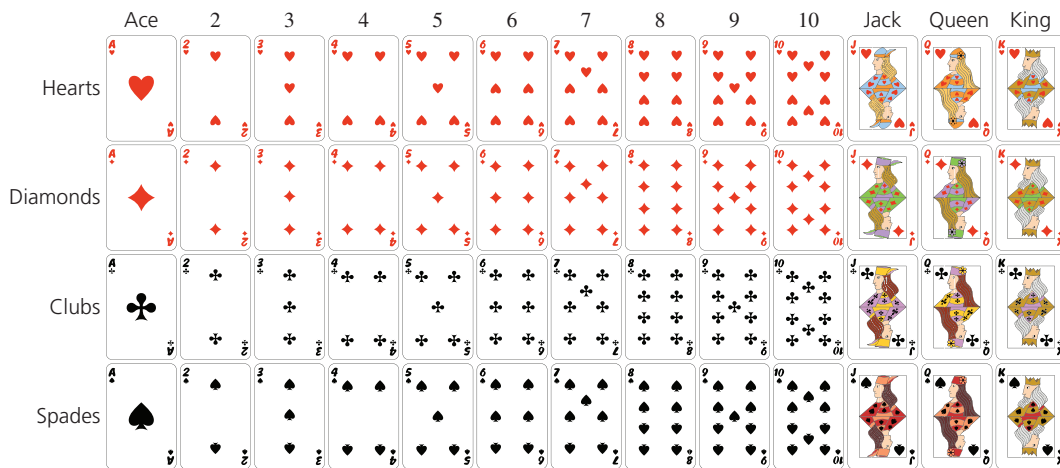

- 12 A six-sided die is tossed and the upper-most face is observed and recorded. Find the following probabilities.

- a $\text{Pr}(6)$ b $\text{Pr}(3)$
 c $\text{Pr}(\text{not a } 3)$ d $\text{Pr}(1 \text{ or } 2)$
 e $\text{Pr}(\text{a number less than } 5)$ f $\text{Pr}(\text{even number or odd number})$
 g $\text{Pr}(\text{square number})$ h $\text{Pr}(\text{not a prime number})$
 i $\text{Pr}(\text{a number greater than } 1)$

Hint: 'Less than 5' means that 5 is not included. Square numbers are $1^2 = 1$, $2^2 = 4$, $3^2 = 9$ etc.



- 13 A letter is chosen at random from the word PROBABILITY. Find the probability that the letter will be:

- a a B
 b not a B
 c a vowel
 d not a vowel
 e a consonant
 f a letter belonging to one of the first five letters in the alphabet
 g a letter from the word RABBIT
 h a letter that is not in the word RABBIT



Faulty CD player

—

14

- 14** A CD contains eight tracks. The time length for each track is shown in the table on the right.

Track	Time (minutes)
1	3
2	4
3	4
4	5
5	4
6	3
7	4
8	4

The CD is placed in a faulty CD player, which begins playing randomly at an unknown place somewhere on the CD, not necessarily at the beginning of a track.

- a** Find the total number of minutes of music available on the CD.
- b** Find the probability that the CD player will begin playing somewhere on track 1.
- c** Find the probability that the CD player will begin somewhere on:
- i** track 2
 - ii** track 3
 - iii** a track that is 4 minutes long
 - iv** track 4
 - v** track 7 or 8
 - vi** a track that is not 4 minutes long



10B Venn diagrams and two-way tables

Learning intentions

- To understand how Venn diagrams and two-way tables are used to show how the sample space is distributed among events
- To be able to use a Venn diagram to display the distribution of two sets
- To be able to fill out a two-way table either from a problem or from a Venn diagram
- To be able to use a Venn diagram or two-way table to calculate probabilities of events

Key vocabulary: Venn diagram, two-way table, probability

When the results of an experiment involve overlapping categories it can be very helpful to organise the information into a Venn diagram or two-way table. Probabilities can easily be calculated from these types of diagrams.

→ Lesson starter: Solving puzzles

Work with a partner to find the answer to each puzzle. For Puzzles 1 – 4, draw some Venn diagrams, like the ones shown, to help you. For Puzzle 5, use a two-way table.

Puzzle 1

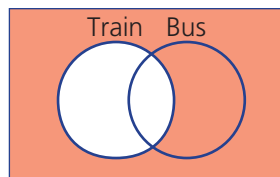

12 students travel to school by bus only and 10 students don't travel by either bus or train.

- How many students don't travel by train?

Puzzle 2

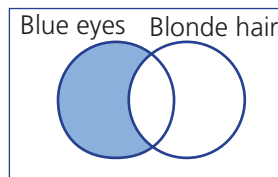

14 students in total have blue eyes, and of these students 5 have both blue eyes and blonde hair.

- How many have blue eyes but not blonde hair?

Puzzle 3

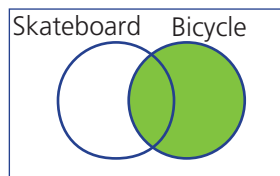

11 students own a bicycle only and 4 students own both a skateboard and a bicycle.

- How many students in total own a bicycle?

Puzzle 4

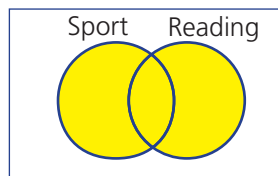

12 students in total like sport, 14 students in total like reading, and 9 students like both sport and reading.

- How many students altogether like either sport or reading or both?

Puzzle 5

A survey of 40 students found that a total of 22 play basketball, 9 play both volleyball and basketball and 6 do not play either basketball or volleyball.

- How many basketball players don't play volleyball?
- How many students in total don't play volleyball?
- How many students in total do play volleyball?

	Basketball	Not Basketball	Total
Volleyball			
Not Volleyball			
Total			

Key ideas

- A **Venn diagram** and a **two-way table** help to organise outcomes into different categories. This example shows the types of computers owned by 100 people.

Venn diagram

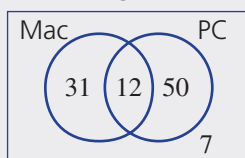

Two-way table

	Mac	No Mac	Total
PC	12	50	62
No PC	31	7	38
Total	43	57	100

These diagrams show, for example, that:

- 12 people own both a Mac and a PC
- 62 people own a PC
- 57 people do not own a Mac
- $\Pr(\text{Mac}) = \frac{43}{100}$
- $\Pr(\text{only Mac}) = \frac{31}{100}$
- $\Pr(\text{Mac or PC}) = \frac{93}{100}$
- $\Pr(\text{Mac and PC}) = \frac{12}{100} = \frac{3}{25}$

Exercise 10B

Understanding

1-4

3, 4

- 1 This Venn diagram shows the number of people who enjoy riding and running.

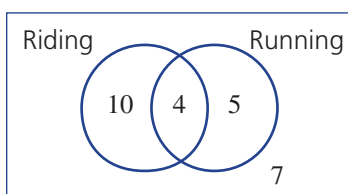

- a** How many people in total are represented by this Venn diagram?
- b** Find how many people enjoy:
- riding only
 - riding (in total)
 - running only
 - running (in total)
 - both riding and running
 - neither riding nor running
 - riding or running or both?
- c** How many people do not enjoy:
- riding?
 - running?

Hint: 'Riding only' does not include the overlapping section.



10B

2 Each statement is about the shaded area in the Venn diagram. State the missing number in each statement.

a _____ people in total like pineapple.

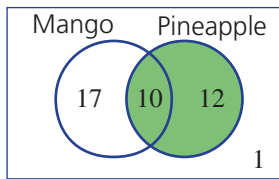

b _____ people like pineapple only.

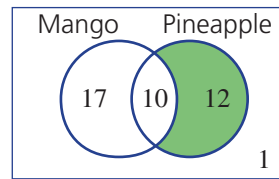

c _____ people like both pineapple and mango.

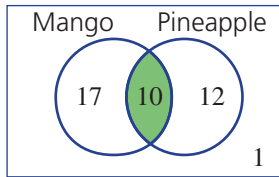

d _____ people like pineapple or mango or both.

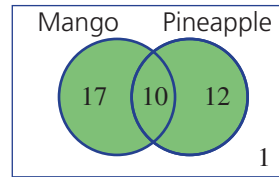

e _____ people don't like mango.

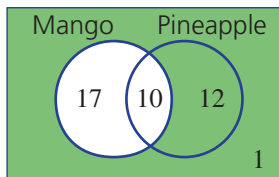

f _____ person likes neither mango nor pineapple.

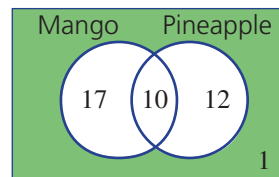

3 Match the diagrams A, B, C or D with the given description.

- a own a cat
- b own a cat only
- c own both a cat and a dog
- d own a cat or a dog or both

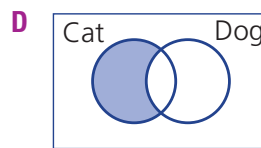
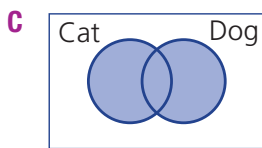
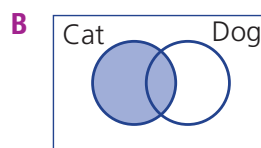
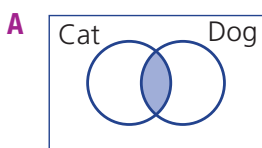

Hint: 'Both a cat and a dog' is where the circles overlap.



4 Fill in the missing numbers in these two-way tables.

a

	A	Not A	Total
B	7	8	
Not B		1	
Total	10		

b

	A	Not A	Total
B	2		7
Not B		4	
Total			20

Hint: Start with the column or row that has two numbers in it.



Fluency

5–8

5–9



Example 3 Constructing a Venn diagram

A survey of 30 people found that 21 like AFL and 12 like soccer. Also, 7 people like both AFL and soccer and 4 like neither AFL nor soccer.

- a** Construct a Venn diagram for the survey results.
- b** How many people:
- like AFL or soccer?
 - do not like soccer?
 - like only AFL?
- c** If one of the 30 people was randomly selected, find:
- $\Pr(\text{like AFL and soccer})$
 - $\Pr(\text{like neither AFL nor soccer})$
 - $\Pr(\text{like only soccer})$

Solution

Explanation

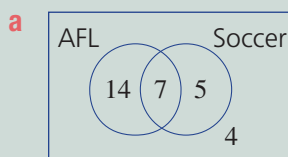

Place the appropriate number in each category. Place the 7 in the overlap first, then ensure that:

- the total that like AFL is 21 ($14 + 7 = 21$).
- the total that like soccer is 12 ($5 + 7 = 12$).

The 4 people that like neither are placed outside the circles.

- b i** 26 like AFL or soccer or both
- ii** $30 - 12 = 18$ don't like soccer
- iii** 14 like AFL but not soccer

The total number of people who like AFL, soccer or both is $14 + 7 + 5 = 26$.

12 like soccer, so 18 do not.

21 like AFL but 7 of these also like soccer.

c i $\Pr(\text{like AFL and soccer}) = \frac{7}{30}$

7 out of 30 people like AFL and soccer.

ii $\Pr(\text{like neither AFL nor soccer})$

The 4 people who like neither AFL nor soccer sit outside both categories.

$$= \frac{4}{30}$$

$$= \frac{2}{15}$$

iii $\Pr(\text{like soccer only})$

5 people like soccer but not AFL.

$$= \frac{5}{30}$$

$$= \frac{1}{6}$$

Continued on next page

Now you try

A survey of 50 people found that 25 watch live TV and 32 people watch streamed shows. Also 14 people watch both live TV and streamed shows and 7 watch neither.

- a** Construct a Venn diagram for the survey results.
- b** How many people:
- watch live TV or streamed shows?
 - do not watch live TV?
 - watch only streamed shows?
- c** If one of the 50 people was randomly selected, find:
- $\Pr(\text{watch live TV and streamed shows})$
 - $\Pr(\text{watch neither live TV nor streamed shows})$
 - $\Pr(\text{watch only live TV})$

- 5** In a class of 30 students, 22 carried a phone and 9 carried an iPad. Three carried both a phone and an iPad and 2 students carried neither.

- a** Copy and complete this Venn diagram.

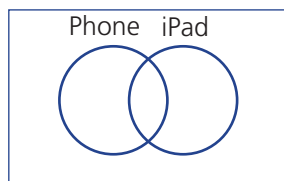

- b** How many students:
- carried a phone or an iPad (includes carrying both)?
 - do not carry an iPad?
 - carry only an iPad?
- c** If one of the 30 students was selected at random, find the following probabilities.
- $\Pr(\text{carry a phone and an iPad})$
 - $\Pr(\text{carry neither a phone nor an iPad})$
 - $\Pr(\text{carry only a phone})$



- 6** Match each diagram with the correct statement.

- Not A
- A or B
- A and B
- B
- B only
- Neither A nor B

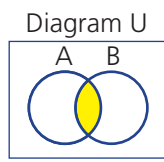
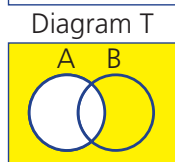
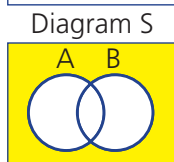
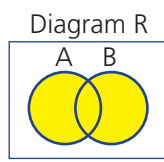
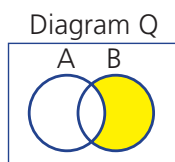
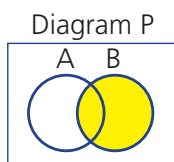

Hint: Start by writing a number in the overlapping section. '22 with a phone' is the total for the phone circle, including the overlap.



Hint: 'A or B' means 'either A or B or both'. 'A and B' means 'both A and B'.



7 For each Venn diagram, find the following probabilities.

- i Pr(A)
 iii Pr(not B)
 v Pr(A or B)
 ii Pr(A only)
 iv Pr(A and B)
 vi Pr(neither A nor B)

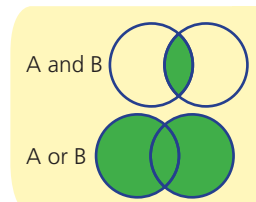
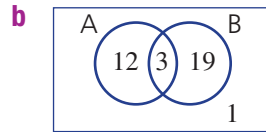
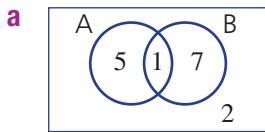

Hint: First calculate the total number in each sample.



Example 4 Constructing a two-way table

At a car yard, 24 cars are tested for fuel economy. Eighteen of the cars run on petrol, 8 cars run on gas and 3 cars can run on both petrol and gas.

- a Illustrate the situation using a two-way table.
 b How many of the cars:
 i do not run on gas?
 ii run on neither petrol nor gas?
 c Find the probability that a randomly selected car:
 i runs on gas
 ii runs on only gas
 iii runs on gas or petrol

Solution

a

	Gas	Not gas	Total
Petrol	3	15	18
Not petrol	5	1	6
Total	8	16	24

Explanation

Set up a table as shown and enter the numbers (in black) from the given information.

Fill in the remaining numbers (in red) ensuring that each column and row adds to the correct total.

b i 16

The total at the base of the 'Not gas' column is 16.

ii 1

The number at the intersection of the 'Not gas' column and the 'Not petrol' row is 1.

c i $\Pr(\text{gas}) = \frac{8}{24}$
 $= \frac{1}{3}$

8 cars in total run on gas out of the 24 cars.

ii $\Pr(\text{only gas}) = \frac{5}{24}$

Of the 8 cars that run on gas, 5 of them do not also run on petrol.

iii $\Pr(\text{gas or petrol}) = \frac{15+5+3}{24}$
 $= \frac{23}{24}$

Of the 24 cars, some run on petrol only (15), some run on gas only (5) and some run on gas and petrol (3).

Continued on next page

10B

Now you try

Of 100 clothing items in a small shop, 65 contained natural fibres, 45 contained artificial fibres and 20 contained both types of fibres.

- a** Illustrate the situation using a two-way table.
- b** How many items:
- do not have artificial fibres?
 - have neither type of fibre?
- c** Find the probability that a randomly selected item:
- has natural fibres
 - has only natural fibres
 - has artificial or natural fibres

- 8** Of 50 desserts served at a restaurant one evening, 25 were served with ice cream, 21 were served with cream and 5 were served with both cream and ice cream.

Hint: 25 is the total for the ice cream row.



- a** Copy and complete this two-way table.

	Cream	Not cream	Total
Ice cream			
Not ice cream			
Total			

- b** How many of the desserts:
- did not have cream?
 - had neither cream nor ice cream?
- c** Find the probability that a chosen dessert:
- had cream
 - had only cream
 - had cream or ice cream



- 9** Find the following probabilities using each of the given tables. First copy and complete each two-way table.

- i** $\Pr(A)$ **ii** $\Pr(\text{not } A)$ **iii** $\Pr(A \text{ and } B)$
iv $\Pr(A \text{ or } B)$ **v** $\Pr(B \text{ only})$ **vi** $\Pr(\text{neither } A \text{ nor } B)$

Hint: 'Neither A nor B' is the same as 'Not A and Not B'.



a

	A	Not A	Total
B	3	1	
Not B	2		4
Total			

b

	A	Not A	Total
B		4	15
Not B	6		
Total			26

Problem-solving and reasoning

10–12

11–14

- 10 For each two-way table, fill in the missing numbers then transfer the information to a Venn diagram.

a

	A	Not A	Total
B	2		8
Not B			
Total		7	12

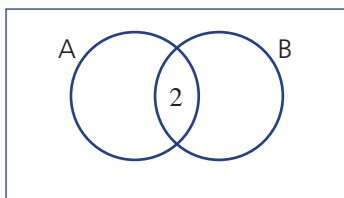

b

	A	Not A	Total
B		4	
Not B	9		13
Total	12		

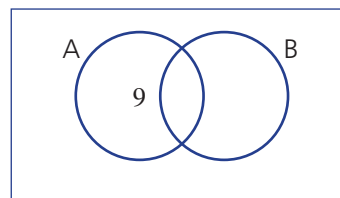

- 11 In a group of 17 people, 13 rented their house, 6 rented a car and 3 did not rent either a car or their house.

- a** Draw a Venn diagram, showing circles for 'Rents house' and 'Rents car'.
b How many people rented both a car and their house?
c Find the probability that one of them rented only a car.

Hint: 14 people will be in the circles, but $13 + 6 = 19$. How many must be in the overlap?



- 12 One hundred citizens were surveyed regarding their use of water in their garden. Of these, 23 said that they used tank water, 48 said that they used tap water and 41 said that they did not use water on their garden at all.

- a** Copy and complete this two-way table.

	Tank water	Not tank water	Total
Tap water			
Not tap water			
Total			

- b** How many people used both tank and tap water?
c What is the probability that one of the people uses only tap water?
d What is the probability that one of the people uses tap water or tank water?



10B

- 13** All members of a ski club enjoy either skiing and/or snowboarding.
Seven enjoy only snowboarding, 16 enjoy skiing and 4 enjoy both snowboarding and skiing.
- Copy and complete the Venn diagram shown.
 - How many people are in the club?
 - If a person from the club is randomly selected, what is the probability of choosing a snowboarder?
 - If a person is randomly selected out of the group that likes skiing, what is the probability of choosing a snowboarder?
 - What is the probability of choosing a skier out of the group that likes snowboarding?
- 14** Of a group of 30 cats, 24 like either tinned or dry food or both, 10 like only dry food and 5 like both tinned and dry food.
- Find the probability that a selected cat likes only tinned food.
 - Out of the group of cats that eat dry food, what is the probability of selecting a cat that also likes tinned food?

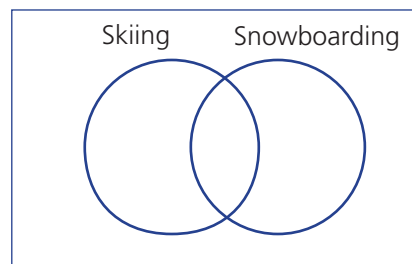

Hint: For part **d**, what fraction of skiers also like snowboarding?



Hint: Use a Venn diagram to record the information.



Numbers challenge

15

- 15** One hundred people were surveyed and it was found that 55 were males and 30 were doctors. The number of male doctors was 17. Copy and complete this Venn diagram and then determine the number of people in each question below.
- The number who are neither male nor a doctor
 - The number who are not males
 - The number who are not doctors
 - The number who are male but not a doctor
 - The number who are a doctor but not male
 - The number who are female and a doctor
 - The number who are female or a doctor

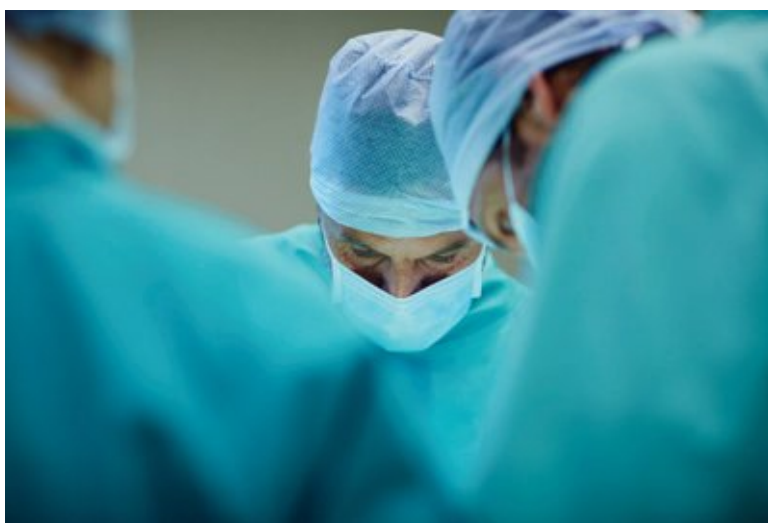
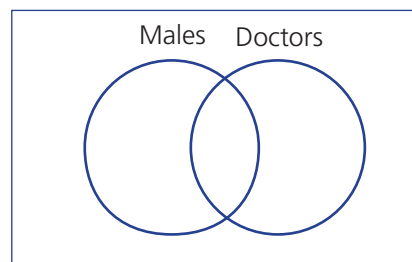

10C Using arrays for two-step experiments

Learning intentions

- To know how to list the sample space of a two-step experiment in an array/table
- To understand the difference between experiments carried out with replacement and without replacement
- To be able to construct arrays for two-step experiments with and without replacement and find associated probabilities

Key vocabulary: array, with replacement, without replacement, two-step experiment, sample space

Sometimes an experiment consists of two steps, such as tossing a single coin twice or rolling two dice. Or perhaps a card is pulled from a hat and then a spinner is spun. We can use tables to list the sample space for such experiments.

→ Lesson starter: The maths cup

This activity can be run in small groups or as a class.

- Draw the table below on the whiteboard. Each student should also have a copy.
- Each student selects one horse as their 'own' (choose a winner!).
- Students take turns to roll 2 dice and state the sum of the uppermost faces of the dice.
- The total of each roll refers to the horse number. When its number is rolled, that horse moves another 100 m towards the finish line. A cross is placed in the cell to show the move.
- The winning horse is the first to reach the finish at 1000 m.
- Keep rolling the dice until first, second and third places are decided.



	Horse	100 m	200 m	300 m	400 m	500 m	600 m	700 m	800 m	900 m	1000 m
1	SCRATCHED										
2	Greased Lightning										
3	Flying Eagle										
4	Quick Stix										
5	Break a Leg										
6	Slow and Steady										
7	The Donkey										
8	The Wombat										
9	Tooting Tortoise										
10	Ripper Racer										
11	Speedy Gonzo										
12	Pharaoh										

→ Discussion questions

- Do you think that the horse that won your maths cup race would always win?
- In this game, do all the horses have the same chance of winning?
- Why is Horse 1 scratched?
- When two dice are thrown, what are all the possible outcomes for the sum of the two uppermost faces?
- What are the horse numbers that are highly likely to win this race?
- What are the horse numbers that are unlikely to win this race?

10C

Key ideas

- An **array** (or table) can be used to list the sample space for experiments involving two steps.
- When listing outcomes, it is important to be consistent with the order for each outcome. For example: the outcome (heads, tails) is different from the outcome (tails, heads). So when two coins are tossed, the Coin 1 outcome is written first in each cell of the table.

		Coin 2	
		H	T
Coin 1	H	HH	HT
	T	TH	TT

The sample space is shown in the central part of the table; i.e. {HH, HT, TH, TT}.

- The probability is still given by:

$$\Pr(\text{Event}) = \frac{\text{number of outcomes where the event occurs}}{\text{total number of possible outcomes}}$$

For example, when two coins are tossed, $\Pr(\text{a tail and a head}) = \frac{2}{4} = \frac{1}{2}$

- Some experiments are conducted **without replacement**, which means that each individual trial outcome cannot be achieved again.

For example: Two letters are chosen from the word CAT. 'Without replacement' means that the first letter chosen is removed and it is not possible to choose it again.

		With replacement			Without replacement			
		2nd			2nd			
		C	A	T	C	A	T	
1st	C	(C, C)	(C, A)	(C, T)	×	(C, A)	(C, T)	
	A	(A, C)	(A, A)	(A, T)	(A, C)	×	(A, T)	
	T	(T, C)	(T, A)	(T, T)	(T, C)	(T, A)	×	

9 outcomes 6 outcomes

Exercise 10C

Understanding

1–4

3, 4

- 1 A letter is chosen from the word HI and a letter is chosen from the word BYE. Copy and complete this table to show the sample space.

		B	Y	E
H	HB			
I				

Hint: Write 'H' in each cell of the top row. Write 'B' in each cell of the first column.



- 2 A coin and a four-sided die are tossed.
- a Copy and complete this table to show the sample space.

	1	2	3	4
H				
T				

Hint: The sample space is all the outcomes in the central part of the table.



- b How many outcomes are in the sample space?
 c What is the probability of tossing a 'H3'?
 d What is the probability of tossing a 'T2'?

- 3 A coin is flipped and then a spinner with numbers 1 to 5 is spun. The possible outcomes are listed in the table below.

	1	2	3	4	5
H	H1	H2	H3	H4	H5
T	T1	T2	T3	T4	T5

- a How many outcomes are possible?
 b List the four outcomes in which an even number is displayed on the spinner.
 c Hence, state the probability that an even number is displayed.
 d List the outcomes for which the coin shows tails and the spinner shows an odd number.
 e What is $\Pr(\text{T, odd number})$?
- 4 Two coins are tossed and the four possible outcomes are shown below.

		20-cent coin	
		H	T
50-cent coin	H	HH	HT
	T	TH	TT

Hint: The same face means either two heads or two tails.



- a What is the probability that the 50-cent coin will be heads and the 20-cent coin will be tails?
 b For which outcomes are the two coins displaying the same face?
 c What is the probability of the two coins displaying the same face?

Fluency

5, 6

5-7



Example 5 Using a table for two-step experiments

A spinner with the numbers 1, 2 and 3 is spun, and then a card is chosen at random from cards containing the letters of ATHS.

- a Draw a table to list the sample space of this experiment.
 b How many outcomes does the experiment have?
 c Find the probability of the combination 2S.
 d Find the probability of an odd number being spun and the letter H being chosen.

Solution

Explanation

a

	A	T	H	S
1	1A	1T	1H	1S
2	2A	2T	2H	2S
3	3A	3T	3H	3S

The sample space of the spinner (1, 2, 3) is put into the left column.

The sample space of the cards (A, T, H, S) is put into the top row.

- b There are 12 outcomes.

The table has $4 \times 3 = 12$ items in it.

c $\Pr(2S) = \frac{1}{12}$

All 12 outcomes are equally likely. Spinning 2 and choosing an S is one of the 12 outcomes.

d $\Pr(\text{odd, H}) = \frac{2}{12} = \frac{1}{6}$

Possible outcomes are 1H and 3H, so probability = $2 \div 12$.

Continued on next page

Now you try

A coin is flipped and an 8-sided die is rolled.

- Draw a table to list the sample space of this experiment.
- How many outcomes does the experiment have?
- Find the probability of the outcome H7.
- Find the probability of obtaining a tail and a number less than 4.

- 5 A coin is flipped and then a regular die is rolled.
- Copy and complete this table to list the sample space for this experiment.
 - How many possible outcomes are there?
 - Find the probability of the pair H3.
 - Find the probability of 'heads' on the coin with an odd number on the die.

	1	2	3	4	5	6
H						
T						

- 6 A letter is chosen from the word LINE and another is chosen from the word RIDE.
- Copy and complete this table to list the sample space.

	R	I	D	E
L				
I				
N				
E				

- How many possible outcomes are there?
- Find $\Pr(N, R)$; i.e. the probability that N is chosen from LINE and R is chosen from RIDE.
- Find $\Pr(L, D)$.
- Find the probability that two vowels are chosen.
- Find the probability that two consonants are chosen.
- Find the probability that the two letters chosen are the same.

Hint: Recall that the vowels are A, E, I, O and U.



- 7 The spinners shown below are each spun.

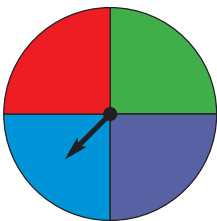

Spinner 1

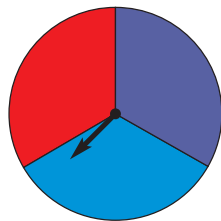

Spinner 2

- Copy and complete this table to list the sample space. Use R for red, P for purple and so on.

		Spinner 2		
		R	P	B
Spinner 1	R			
	P			
	G			
	B			

Hint: List the colour from spinner 1 first in each cell.



- Find the probability that spinner 1 will display red and spinner 2 will display blue.
- Find the probability that both spinners will display red.
- What is the probability that one of the spinners displays red and the other displays blue?
- What is the probability that both spinners display the same colour?

Problem-solving and reasoning

8–10

8, 10, 11

- 8 Two dice are rolled for a board game. The numbers showing are then added together to get a number between 2 and 12.

		Die 1					
		1	2	3	4	5	6
Die 2	1						
	2						
	3						
	4						
	5						
	6						

Hint: Write the sum in each cell. For example, for (1, 1), write 2.



- Copy and complete a table like the one above to show the sample space. State the number of outcomes.
- Find the probability that the two dice add to 5.
- Find the probability that the two dice add to an even number.
- What is the most likely sum to occur?
- What are the two least likely sums to occur between 2 and 12?



- 9 In Rosemary's left pocket she has two orange marbles and one white marble. In her right pocket she has a yellow marble, a white marble and 3 blue marbles. She chooses a marble at random from each pocket.
- Draw a table to describe the sample space.
 - Find the probability that she will choose an orange marble and a yellow marble.
 - What is the probability that she chooses a white marble and a yellow marble?
 - What is the probability that she chooses a white marble and an orange marble?
 - Find the probability that a white and a blue marble are selected.
 - What is the probability that the two marbles selected are the same colour?

Hint: The left-pocket outcomes are W, O, O.



10C



Example 6 Finding the sample space for events without replacement

The letters **T** **R** **E** **K** are written on cards. A letter is chosen and not replaced so that this letter is now unavailable. Then a second letter is chosen.

- In a table, list the outcomes from choosing two letters without replacement.
- Find the probability that the two letters chosen are (E, R), in that order.
- Find the probability of obtaining an outcome with an E in it.

Solution

a

		1st choice			
		T	R	E	K
2nd choice	T	×	(R, T)	(E, T)	(K, T)
	R	(T, R)	×	(E, R)	(K, R)
	E	(T, E)	(R, E)	×	(K, E)
	K	(T, K)	(R, K)	(E, K)	×

Explanation

List all the outcomes, writing the '1st choice' letter first in each cell. Note that the same letter cannot be chosen twice.

b $\Pr(E, R) = \frac{1}{12}$

Without replacement there are 12 outcomes.

c $\Pr(\text{includes E}) = \frac{6}{12} = \frac{1}{2}$

6 of the 12 outcomes contain an E.

Now you try

Two digits are selected from the set {3, 5, 6} without replacement.

- Draw a table to list the sample space.
- Find the probability that the outcome (5, 6) will be the result.
- Find the probability that (5, 6) or (6, 5) will be the result.

- 10** Two letters are chosen from the word *DOG* *without replacement*.

- a** Complete the given table.

		1st		
		D	O	G
2nd	D	×	(O, D)	(G, D)
	O		×	
	G			×

- Find the probability of obtaining the (G, D) outcome.
- Find the probability of obtaining an outcome with an O in it.

Hint: 'Without replacement' means the first letter chosen is removed, so it is not possible to choose it again.



- 11 Two digits are selected *without replacement* from the set $\{1, 2, 3, 4\}$.
- Draw a table to show the sample space.
 - Find:
 - $\text{Pr}(1, 2)$
 - $\text{Pr}(4, 3)$
 - Find the probability that:
 - both numbers will be at least 3
 - the outcome will contain a 1 or a 4
 - the outcome will contain a 1 and a 4
 - the outcome will not contain a 3

Hint: Remember that doubles such as $(1, 1)$, $(2, 2)$ etc. are not allowed.



Hint: 'At least 3' includes 3.



Game show

12

- 12 A wheel is spun during a game show to determine the prize money, and then a six-sided die is rolled. The prize money shown on the wheel is multiplied by the number on the die to give the total winnings.
- What is the probability that a contestant will win \$6000?
 - What is the probability that they win more than \$11 000?

Hint: Draw a table to show all outcomes. List the prize in brackets under each outcome.

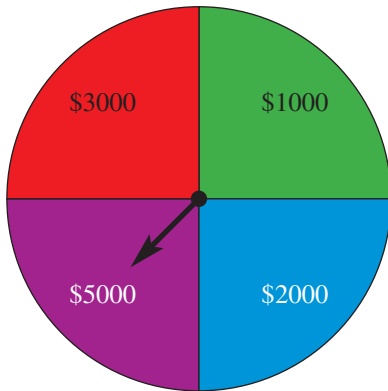

10D Tree diagrams

Learning intentions

- To know how to use a tree diagram to list the sample space from experiments with two or more steps
- To be able to construct the sample space using tree diagrams for experiments with replacement and those without replacement
- To be able to use a tree diagram to find the probability of certain events

Key vocabulary: tree diagram, with replacement, without replacement, sample space

When two coins are flipped, we can draw a table to list the sample space. Yet if three coins are flipped, then we would need a three-dimensional table to list all outcomes. Imagine trying to find probabilities when five coins are flipped!

Another tool that mathematicians use for probability is the tree diagram. This tree diagram describes the four outcomes when two coins are flipped.

It is important to be able to read a tree diagram correctly. The first row (HH) represents the outcome where the first coin flipped was heads and the second coin flipped was heads. The third row (TH) represents the outcome where the first coin was tails and the second was heads.

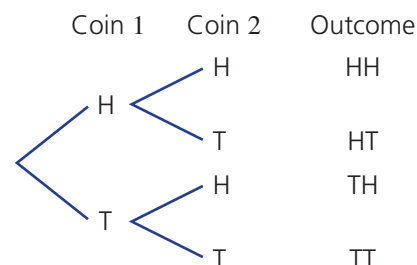

→ Lesson starter: Coin puzzle

If two coins are flipped, rank these outcomes from most likely to least likely:

- Exactly two heads are obtained.
- Exactly one head and exactly one tail are obtained.
- At least one coin shows tails.
- Three tails are shown.

How might the order change if three coins are flipped? Compare your answers with other students.

Key ideas

- **Tree diagrams** are diagrams used to list the sample space for multistage experiments with two or more steps.

- The outcomes for each stage of the experiment are listed vertically and each stage is connected with branches.

For example:

Tossing a coin 3 times (with replacement)

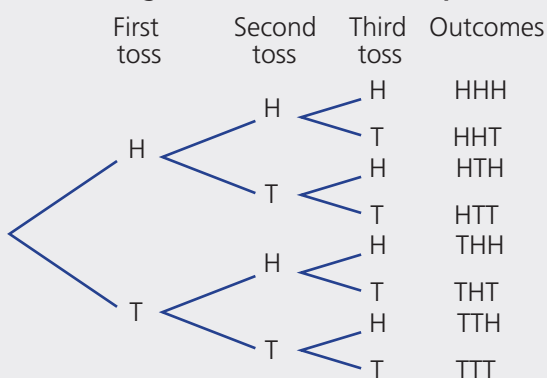

Selecting 2 letters from {A, B, C} (without replacement)

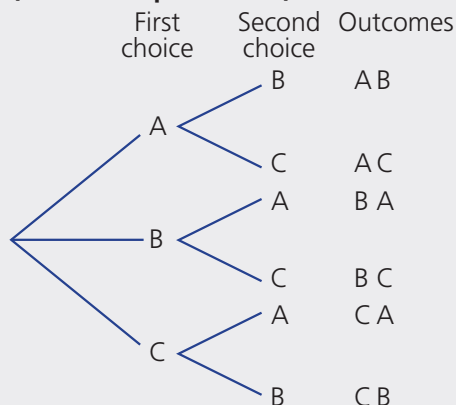

In these examples, each set of branches produces outcomes that are all equally likely. Tree diagrams can also be used where all outcomes are not equally likely.

Exercise 10D

Understanding

1-3

1, 3

- 1 These two tree diagrams show the selection of two letters from the word CAT.

A

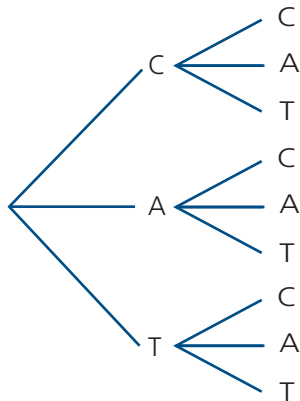

B

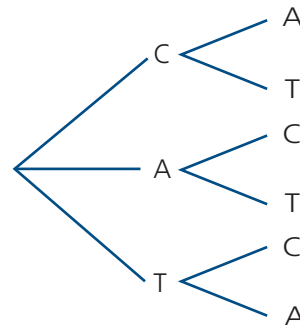

- a Which tree diagram shows selection 'with replacement'?
b Which tree diagram shows selection 'without replacement'?

- 2 The letters S, K and Y are written on cards and placed in a hat. Two letters are randomly selected one at a time.

- a Write the missing word or number from each statement about this event.

- i 'With _____' means the first letter is returned to the hat before the second letter is selected.
ii When the first letter chosen is replaced, there are still _____ letters to choose from for the second letter.

- b Copy and complete this tree diagram for selecting two letters *with replacement*.

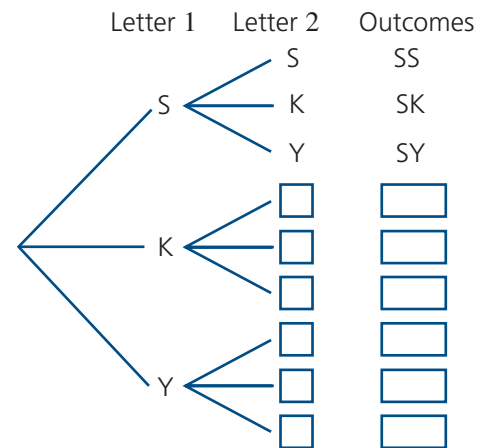

- 3 The letters T, W and O are written on cards and placed in a container. One letter is randomly selected and not returned to the container. A second letter is then selected.

- a Write the missing word or number from each statement about this event.

- i _____ means the first letter chosen is placed aside and the second letter is selected from the remaining letters.
ii Since the first letter chosen is not replaced, there will be only _____ letters to choose from for the second letter.

- b Complete the tree diagram for selecting two letters *without replacement* from the letters T, W and O.

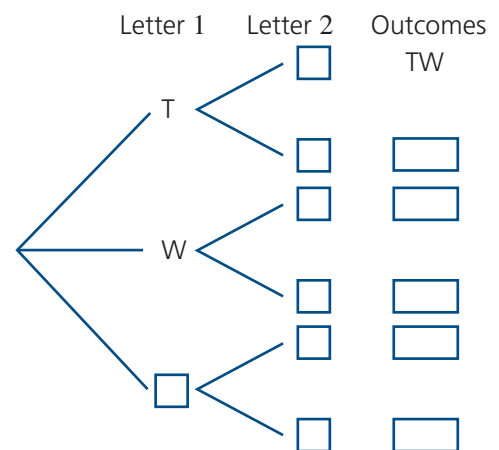



Example 7 Constructing a tree diagram

An experiment involves tossing two coins.

- a** Complete a tree diagram to show all possible outcomes.
b What is the total number of outcomes?
c Find the probability of tossing:
- i** two tails **ii** one tail **iii** at least one head

Solution

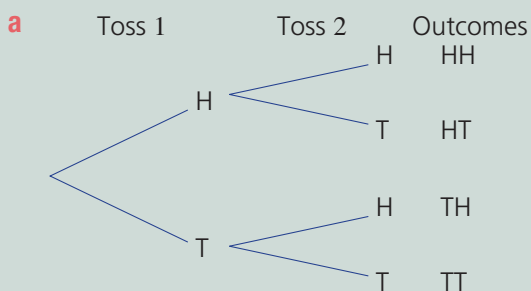

Explanation

Tree diagram shows two coin tosses one after the other, resulting in $2 \times 2 = 4$ outcomes.

- b** The total number of outcomes is 4.

There are four possibilities in the outcomes column.

c i $\Pr(\text{TT}) = \frac{1}{4}$

One out of the four outcomes is TT.

ii $\Pr(\text{1 tail}) = \frac{2}{4} = \frac{1}{2}$

Two outcomes have one tail: {HT, TH}

iii $\Pr(\text{at least 1 head}) = \frac{3}{4}$

Three outcomes have at least one head: {HH, HT, TH}

Now you try

An experiment involves tossing two 4-sided dice.

- a** Complete a tree diagram to show all possible outcomes.
b What is the total number of outcomes?
c Find the probability of tossing:
- i** two 3's **ii** one 4 **iii** at most one 2

- 4** A coin is tossed twice.
- a** Complete this tree diagram to show all the possible outcomes.
b What is the total number of outcomes?
c Find the probability of obtaining:
- i** two heads
ii exactly one head
iii at least one head
iv at least one tail

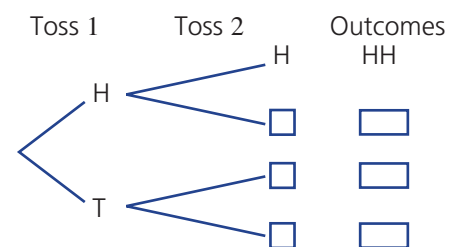

Hint: 'At least one' means one or two in this case.



- 5 A spinner with numbers 1, 2 and 3 is spun twice.
- Draw a tree diagram and list the outcomes.
 - Find $\text{Pr}(1 \text{ then } 1)$.
 - Find $\text{Pr}(1 \text{ then } 2)$.
 - Find $\text{Pr}(1 \text{ and } 2 \text{ spun in either order})$.
 - Find $\text{Pr}(\text{both show the same number})$.
 - Find $\text{Pr}(\text{numbers add to } 4)$.

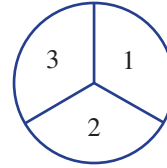

Hint: Tree diagram headings: 'First spin', 'Second spin', 'Outcomes'.



Example 8 Constructing a tree diagram without replacement

Two people are selected without replacement from a group of three: Annabel (A), Brodie (B) and Chris (C).

- List all the possible combinations for the selection using a tree diagram.
- Find the probability that the selection will contain:
 - Annabel and Brodie
 - Chris
 - Chris or Brodie

Solution

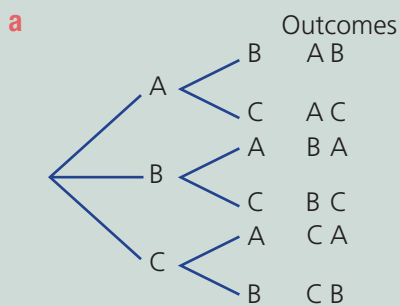

Explanation

On the first choice there are three options (A, B or C) but on the second choice there are only two remaining.

b i $\text{Pr}(\text{Annabel and Brodie}) = \frac{2}{6}$
 $= \frac{1}{3}$

2 of the 6 outcomes contain Annabel and Brodie (AB) and (BA).

ii $\text{Pr}(\text{Chris}) = \frac{4}{6}$
 $= \frac{2}{3}$

4 out of the 6 outcomes contain Chris.

iii $\text{Pr}(\text{Chris or Brodie}) = \frac{6}{6}$
 $= 1$

All of the outcomes contain at least one of Chris or Brodie.

Now you try

A drawer contains two red and one blue sock. Two socks are selected at random without replacement.

- List all the possible combinations for the selection using a tree diagram.
- Find the probability that the selection will contain:
 - two red socks
 - two socks of different colour
 - at least one red sock.

10D

- 6 Two people are selected without replacement from a group of three: Donna (D), Elle (E) and Fernando (F).
- List all the possible combinations for the selection using a tree diagram.
 - Find the probability that the selection will contain:
 - Donna and Elle
 - Fernando
 - Fernando or Elle

Hint: The combinations are the outcomes.



- 7 A drawer contains 2 red socks (R), 1 blue sock (B) and 1 yellow sock (Y) and two socks are selected at random without replacement.
- Complete this tree diagram.
 - Find the probability of obtaining:
 - a red sock and a blue sock
 - two red socks
 - any pair of socks of the same colour
 - any pair of socks of different colour

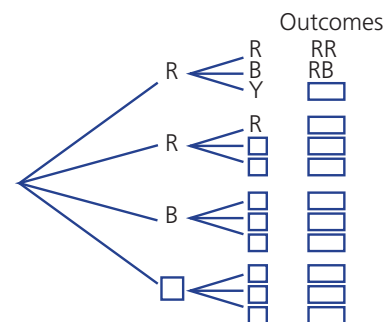

Problem-solving and reasoning

8

8, 9

- 8 A coin is tossed three times.
- Draw a tree diagram and list the outcomes.
 - Find $\text{Pr}(3 \text{ tails})$.
 - Find $\text{Pr}(2 \text{ tails then } 1 \text{ head})$.
 - Find $\text{Pr}(2 \text{ tails and } 1 \text{ head, in any order})$.
 - Which is more likely: getting exactly 3 tails or getting exactly 2 tails?
- 9 There are three bottles of white wine and two bottles of red wine on a shelf in a cellar. It is too dark to read the labels so two bottles are randomly selected, one at a time. Find the probability that:
- two bottles of different colour wine are selected
 - two bottles of the same colour wine are selected
 - one or more bottles of red wine are selected

Hint: Use headings: 'Coin 1', 'Coin 2', 'Coin 3', 'Outcomes'.



Hint: Draw a tree diagram using the 'without replacement' method.



Selecting matching clothes

—

10

- 10 A man randomly selects a tie from his collection of one green and two red ties. He selects a shirt from a collection of one red and two white. He then selects either a red or black hat. Use a tree diagram to help find the probability that the man selects a tie, shirt and hat according to the following descriptions:
- a red tie, red shirt and black hat
 - all three items red
 - one item red
 - two items red
 - at least two items red
 - a green hat
 - a green tie and a black hat
 - a green tie or a black hat
 - not a red item
 - a red tie or white shirt or black hat



10E Experimental probability

Learning intentions

- To understand how experimental probability is calculated
- To be able to calculate experimental probability
- To be able to calculate the expected number of occurrences given the experimental probability

Key vocabulary: expected number of occurrences, experimental probability, experiment, favourable outcome, survey

The sample space is used to calculate theoretical probability. Experimental probability, however, is calculated from the results of a survey, an experiment or a simulation. A larger number of trials make experimental probability calculations more accurate. Experimental probability is used to predict an expected number of results.



Fishermen use experimental data to decide on the bait, place and time of day that gives the highest probability of catching a fish.

→ Lesson starter: Newspaper theories

A tabloid newspaper reports that of 10 people interviewed in the street, 5 had a dose of the flu. At a similar time a medical student tested 100 people and found that 21 had the flu.

- What is the experimental probability of having the flu, according to the newspaper's survey?
- What is the experimental probability of having the flu, according to the medical student's results?
- Which of the two sets of results would be most reliable and why? Discuss the reasons.
- Using the results from the medical student, how many people would you expect to have the flu in a group of 1000, and why?

Key ideas

- **Experimental probability** is calculated using the results of an experiment or **survey**.
 - Experimental probability is a relative frequency calculated from a number of repeated trials.

$$\text{Experimental probability} = \frac{\text{number of times the outcome occurs}}{\text{total number of trials in the experiment}}$$

- The **expected number of occurrences** is the expected number of favourable outcomes from an experiment.
 - Expected number of occurrences = probability \times number of trials

Exercise 10E

Understanding

1, 2

2

- Insert the word *experimental*, *theoretical* or *expected* to complete each statement.
 - _____ probability is calculated from the results of an experiment or survey.
 - _____ probability is calculated from the sample space of an event.
 - When a coin is tossed, there are 2 possible equally likely outcomes. So the _____ probability of obtaining a head is $\frac{1}{2}$.
 - Jayce tossed a coin 20 times and obtained a head 12 times. So the _____ probability of obtaining a head was $\frac{12}{20} = \frac{3}{5}$.
 - A survey found that 3 out of every 5 students have a sister. Out of 1000 students, the _____ number of students with a sister would be $\frac{3}{5} \times 1000 = 600$.
- Write the experimental probability from each set of results listed here.
 - Out of 20 people surveyed, 18 preferred cereal for breakfast.
 - 50 students were surveyed and it was found that 40 had pets.
 - There were 25 boys and 20 girls at the school bus stop one afternoon. If one child is selected from those at the bus stop, state the experimental probability that the child is a boy.

Hint: In part c, first find the total number of students at the bus stop.



Fluency

3–7

4–8



Example 9 Using experimental probability

Kris plays rugby and has a record of kicking a goal from a penalty kick 4 times out of every 7 attempts.

- State the experimental probability for Kris to achieve a penalty goal.
- Calculate the expected number of goals from 28 penalty kicks that Kris takes.

Solution

Explanation

- | | | |
|---|--|--|
| a | $\text{Pr}(\text{goal}) = \frac{4}{7}$ | Experimentally, we know that Kris can kick 4 goals out of every 7 kicks. |
| b | Expected number = $\frac{4}{7} \times 28 = 16$ goals | Expected number = probability \times number of trials |

Now you try

In the last 10 school days Mia caught the correct bus in the morning 8 times.

- State the experimental probability of Mia catching the correct bus in the morning on the next school day.
- Calculate the expected number of times Mia will catch the correct morning bus in the next 50 school days.

- 3 Ashleigh has found that she can shoot a basketball through the hoop 4 times out of 10 from the '3 point' area.
- State the experimental probability for Ashleigh to shoot a basketball through the hoop from the '3 point' area.
 - Calculate the expected number of times the ball would go through the hoop from 100 shots Ashleigh makes from the '3 point' area.

- 4 The experimental probability of Jess hitting a bullseye on a dartboard is 0.05 (or $\frac{5}{100}$). How many bullseyes would you expect Jess to get if he threw the following number of darts?

- 100 darts
- 200 darts
- 1000 darts
- 80 darts

Hint: Expected number
= probability
× number of trials



- 5 A bus company surveyed a random selection of 90 people in one suburb. They found that 35 of these people regularly used a bus service from that suburb to the centre of the city.
- State the experimental probability for a person in that suburb to regularly use a bus service from that suburb to the city.
 - If there are 2700 residents in that suburb, find the expected number who would regularly use a bus service from that suburb to the city.



Example 10 Finding the experimental probability

A box contains an unknown number of coloured balls and a ball is drawn from the box and then replaced. The procedure is repeated 100 times and the colour of the ball drawn is recorded each time. Twenty-five red balls were recorded.

- Find the experimental probability for selecting a red ball.
- Find the expected number of red balls if the box contained 500 balls in total.

Solution

$$\begin{aligned} \text{a } \Pr(\text{red balls}) &= \frac{25}{100} \\ &= 0.25 \end{aligned}$$

$$\begin{aligned} \text{b } \text{Expected number of red balls in 500} \\ &= 0.25 \times 500 \\ &= 125 \end{aligned}$$

Explanation

$$\Pr(\text{red balls}) = \frac{\text{number of red balls drawn}}{\text{total number of balls drawn}}$$

There are 25 red balls and 100 balls in total.

$$\begin{aligned} \text{Expected number of occurrences} \\ &= \text{probability} \times \text{number of trials} \end{aligned}$$

Now you try

120 people were surveyed and asked if they had contracted the flu in the last 12 months. 25 responded Yes, 90 responded No and the remainder responded Not sure.

- Find the experimental probability that a person contracted the flu in the last 12 months.
- Find the expected number of people who contracted the flu in the last 12 months if 960 people are surveyed.

10E

- 6 A bag contains an unknown number of counters. A counter is selected from the bag and then replaced. The procedure is repeated 100 times and the colour of the counter is recorded each time. Sixty of the counters drawn were blue.
- a** Find the experimental probability for selecting a blue counter.
- b** Find the expected number of blue counters if the bag contained:
- i** 100 counters **ii** 200 counters **iii** 600 counters
- 7 In an experiment involving 200 people chosen at random, 175 people said that they owned a home computer.
- a** Calculate the experimental probability of choosing a person who owns a home computer.
- b** Find the expected number of people who would own a home computer in the following group sizes:
- i** 400 people **ii** 5000 people **iii** 40 people
- 8 By calculating the experimental probability, estimate the chance that each of the following events will occur.
- a** Nat will walk to work today, given that she walked to work five times in the last 75 working days.
- b** Mike will win the next game of cards if, in the last 80 games, he has won 32.
- c** Brett will hit the bullseye on the dartboard with his next attempt if, in the last 120 attempts, he was successful 22 times.

Hint: Experimental probability

$$= \frac{\text{number of blue counters}}{\text{total number of counters selected}}$$



Hint: Expected number

$$= \text{probability} \times \text{number of trials}$$



Problem-solving and reasoning

9–11

10–13

- 9 This table shows the results of three different surveys of people in Perth about their use of public transport (PT).

Survey	Number who use PT	Survey size	Experimental probability
A	2	10	$\frac{2}{10} = 0.2$
B	5	20	_____
C	30	100	_____

Hint: A large survey size makes experimental probability calculations more accurate.



- a** What are the two missing numbers in the experimental probability list?
- b** Which survey should be used to estimate the probability that a person uses public transport and why?
- 10 The results of tossing a drawing pin and observing how many times the pin lands with the spike pointing up are shown in the table. Results are recorded at different stages of the experiment.

Number of throws	Frequency (spike up)	Experimental probability
1	1	1.00
5	2	0.40
10	5	0.50
20	9	0.45
50	18	0.36
100	41	0.41



Experimental probability shows that the chance of a drawing pin landing spike-up or spike-down is not 50 : 50.

Which experimental probability would you choose to best represent the probability that the pin will land spike up? Why?

- 11 A six-sided die is rolled 120 times. State how many times you would expect the following events to occur?
- a a 6
 - b a 1 or a 2
 - c a number less than 4
 - d a number which is at least 5

Hint: Use the theoretical probability to calculate the expected numbers.



- 12 The colour of cars along a highway was noted over a short period of time and summarised in this frequency table.

Colour	White	Silver	Blue	Green
Frequency	7	4	5	4



- a How many cars had their colour recorded?
- b Find the experimental probability that a car's colour is:
 - i blue
 - ii white
- c If the colour of 100 cars was recorded, find the expected number of:
 - i blue cars
 - ii green cars
 - iii blue or green cars

- 13 A spinner is divided into three regions not necessarily of equal size. The regions are numbered 1, 2 and 3 and the spinner is spun 50 times. The table shows the results.

Number	1	2	3
Frequency	26	11	13

- a Find the experimental probability of obtaining:
 - i a 1
 - ii at least a 2
 - iii a 1 or a 3
- b Based on these results, how many 3s would you expect if the spinner is spun 300 times?
- c In fact, the spinner is divided up using simple and common fractions. Draw and label how you think the spinner regions are divided up.

Hint: The angles of the spinner regions are multiples of 90° .



Different-shaped dart boards

—

14



- 14 One hundred darts are randomly thrown at the given dartboards. No darts miss the dartboard entirely. How many darts do you expect to hit the blue shaded region? Give reasons.

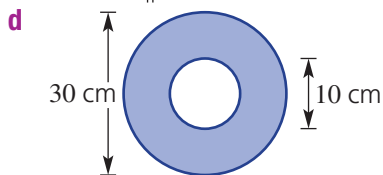
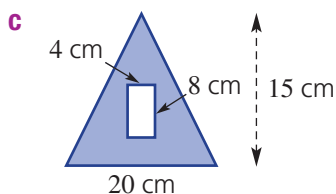
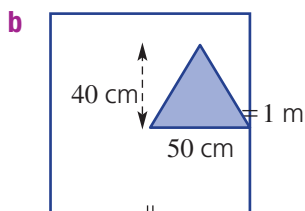
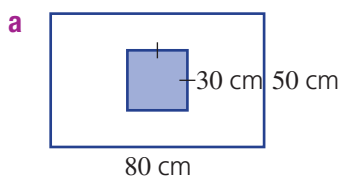

Hint: First find the proportion of the entire dartboard taken up by each blue region.



10F Summarising data: range and measures of centre

Learning intentions

- To know that measures of centre are used to summarise a data set
- To be able to find the mean, median, mode and range of a set of data
- To know how the median is found for data sets with an odd or even number of values
- To understand that an outlier is a value much smaller or larger than the rest of the data

Key vocabulary: mode, mean, range, median, outlier, bimodal

Statistics involves collecting and summarising data. It also involves drawing conclusions and making predictions. The type and amount of product stocked on supermarket shelves, for example, is determined by the sales statistics and other measures such as average cost and price range.

Lesson starter: Game purchase

Arathi purchases 7 computer games at a sale. 3 games cost \$20 each, 2 games cost \$30, 1 game costs \$50 and the last game cost \$200.

- Recall and discuss the meaning of the words mean, median and mode.
- Can you work out the mean, median or mode for the cost of Arathi's games?
- Which of the mean, median or mode gives the best 'average' for the cost of Arathi's games?
- Why is the mean greater than the median in this case?

Key ideas

Mean \bar{x}

The mean, \bar{x} , of a set of numbers is given by

$$\bar{x} = \frac{\text{sum of all the values}}{\text{number of scores}}$$

$$\begin{aligned} \text{For example, mean} &= \frac{6 + 7 + 10 + 12 + 13}{5} \\ &= 9.6 \end{aligned}$$

Median

The median is the middle value if the data is placed in order.

- If there are two middle values, the median is calculated as the mean of these two values.

odd number of values	even number of values
<div style="display: flex; justify-content: space-around; align-items: center;"> <div style="border: 1px solid black; padding: 2px 5px;">1</div> <div style="border: 1px solid black; padding: 2px 5px;">3</div> <div style="border: 1px solid black; padding: 2px 5px;">5</div> <div style="border: 1px solid black; padding: 2px 5px; border-radius: 50%;"><u>5</u></div> <div style="border: 1px solid black; padding: 2px 5px;">6</div> <div style="border: 1px solid black; padding: 2px 5px;">7</div> <div style="border: 1px solid black; padding: 2px 5px;">10</div> </div> <p style="text-align: center; margin-top: 5px;">median</p>	<div style="display: flex; justify-content: space-around; align-items: center;"> <div style="border: 1px solid black; padding: 2px 5px;">13</div> <div style="border: 1px solid black; padding: 2px 5px;">17</div> <div style="border: 1px solid black; padding: 2px 5px;">17</div> <div style="border: 1px solid black; padding: 2px 5px;">20</div> <div style="border: 1px solid black; padding: 2px 5px;">21</div> <div style="border: 1px solid black; padding: 2px 5px;">27</div> <div style="border: 1px solid black; padding: 2px 5px;">27</div> <div style="border: 1px solid black; padding: 2px 5px;">28</div> </div> <div style="text-align: center; margin-top: 5px;"> $\frac{20 + 21}{2} = 20.5$ median </div>

- The **mode** is the most common value.
 - There can be more than one mode.
 - If there are two modes, we say that the data set is **bimodal**.
- An **outlier** is a score that is much larger or smaller than the rest of the data.
- The **range** is the difference between the highest and lowest values.
 Range = maximum value – minimum value

Exercise 10F

Understanding

1–5

1–5

- 1 a** To calculate the _____, you add up all the values and divide by the number of values.
b Find the mean of these data sets (round each answer to one decimal place).
i 3 6 8 10 12
ii 6 8 4 12 9 11 16 13
- 2 a** The mode is the most _____ value.
b State the mode of these data sets.
i 1 2 2 2 4 5 6
ii 1 4 8 8 9 10 10 10 12
- 3 a** The median is the _____ value when the scores are listed in order.
b Find the median of these data sets.
i 1 3 5 6 8
ii 4 5 7 9 10 11
- 4 a** The _____ is the difference between the highest and lowest values.
b Find the range of these data sets.
i 3 6 7 12 15 24
ii 5 12 14 18 23 27
- 5 a** An _____ is a score that is much larger or smaller than the rest of the data.
b For each of these data sets, if there is an outlier, state its value.
i 2 4 5 4 6 2 3 36
ii 21 25 3 27 28 24 29 30

Hint: First find the sum of the scores, then divide by the number of scores. Mean = $\frac{39}{5}$



Hint: Range = highest value – lowest value



Fluency

6(½), 7, 8

6(½), 7–9



Example 11 Finding measures of centre

For the given data sets, find the following:

- i** the mean **ii** the median **iii** the mode **iv** the range

a 5 2 4 10 6 1 2 9 6

b 17 13 26 15 9 10

Solution

a i Mean = $\frac{45}{9}$
= 5

5 + 2 + 4 + 10 + 6 + 1 + 2 + 9 + 6 = 45
Find the sum of all the numbers and divide by the number of values.

ii 1 2 2 4 (5) 6 6 9 10
Median = 5

First, order the data.

The median is the middle value.

iii Mode = 2 and 6

The data set is bimodal since there are two numbers with the highest frequency.

iv Range = 10 – 1
= 9

The range is the highest score minus the lowest score.

Continued on next page

10F

$$\begin{aligned} \text{b i Mean} &= \frac{90}{6} \\ &= 15 \end{aligned}$$

$$17 + 13 + 26 + 15 + 9 + 10 = 90$$

There are 6 values.

$$\text{ii } 9 \ 10 \ 13 \ 15 \ 17 \ 26$$

14

First, order the data.

Since there are two values in the middle, find the mean of them.

$$\begin{aligned} \text{Median} &= \frac{13 + 15}{2} \\ &= 14 \end{aligned}$$

iii No mode

None of the values are repeated so there is no mode.

$$\begin{aligned} \text{iv Range} &= 26 - 9 \\ &= 17 \end{aligned}$$

The highest score is 26 and the lowest score is 9.

Now you try

For the given data sets, find the following:

i the mean

ii the median

iii the mode

iv the range

a 8 4 2 7 7 3 4 7 3

b -4 2 0 1 -1 0 3 5



6 For the given data sets, find:

i the mean

ii the median

iii the mode

iv the range

a 7 2 3 8 5 9 8

b 6 13 5 4 16 10 3 5 10

c 12 9 2 5 8 7 2 3

d 10 17 5 16 4 14

e 3.5 2.1 4.0 8.3 2.1

f 0.7 3 2.9 10.4 6 7.2 1.3 8.5

g 6 0 -3 8 2 -3 9 5

h 3 -7 2 3 -2 -3 4

Hint: Recall that to subtract a negative, you add a positive; e.g. $7 - (-2) = 7 + 2 = 9$.



7 These data sets include an outlier. Calculate the mean and the median and write down the outlier. Include the outlier in your calculations.

a 5 7 7 8 12 33

b 2 40 42 45 47

c 1.3 1.1 1.0 1.7 1.5 1.6 -1.1 1.5

d -58 -60 -59 -4 -64

Hint: An outlier is much larger or smaller than the other scores.



8 Decide whether the following data sets are bimodal.

a 2 7 9 5 6 2 8 7 4

b 1 6 2 3 3 1 5 4 1 9

c 10 15 12 11 18 13 9 16 17

d 23 25 26 23 19 24 28 26 27

Hint: Bimodal means that there are two modes.





- 9 This ordered data set shows the number of fish Daniel caught in the 12 weekends that he went fishing during the year.

1 2 3 4 4 5 6 7 7 9 11 13

- Find the range.
- Find the median.
- Find the mean.
- Find the mode.

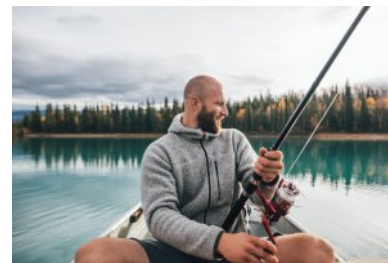

Problem-solving and reasoning

10–12

11–13



- 10 In three running races, Paula recorded the times 25.1 seconds, 24.8 seconds and 24.1 seconds.

- What is the mean time of the races? Round to two decimal places.
- Find the median time.



- 11 This is a data set of six house prices in Darwin.

\$324 000 \$289 000 \$431 000 \$295 000 \$385 000 \$1 700 000

- Which price would be considered the outlier?
- If the outlier was removed from the data set, by how much would the median change? (First work out the original median house price.)
- If the outlier was removed from the data set, by how much would the mean change, to the nearest dollar? (First work out the original mean house price.)

Hint: To find the median, list the prices in order, then find the middle value.



Example 12 Finding a data value for a required mean

The hours a shop assistant spends cleaning the store in eight successive weeks are:
8, 9, 12, 10, 10, 8, 5, 10

- Calculate the mean for this set of data.
- Determine the number of hours that needs to be added to this data to make the mean equal to 10.

Solution

Explanation

$$\begin{aligned} \text{a Mean} &= \frac{72}{8} \\ &= 9 \end{aligned}$$

$8 + 9 + 12 + 10 + 10 + 8 + 5 + 10 = 72$.
Sum of the 8 data values is 72.

- b Let a be the new score.

$$\text{Require } \frac{72 + a}{8 + 1} = 10$$

$$\frac{72 + a}{9} = 10$$

$$72 + a = 90$$

$$a = 18$$

$72 + a$ is the total of the new data and $8 + 1$ is the new total number of scores. Set this equal to the required mean of 10.

Solve for a .

9 scores have a mean of 10, so the sum of the scores = $9 \times 10 = 90$.

The new score would need to be 18.

Write the answer.

Now you try

Amanda received scores of 85, 91, 94 and 78 on her last four maths tests.

- Calculate the mean for this set of data.
- Determine the score that needs to be added to this data to make the mean equal to 89.

10F



- 12 A netball player scored the following number of goals in her 10 most recent games:

15 14 16 14 15 12 16 17 16 15

- What is her mean score?
- What number of goals does she need to score in the next game for the mean of her scores to be 16?



- 13 Stevie obtained the following scores on her first five Maths tests: 92 89 94 82 93

- What is her mean test score?
- If there is one more test left to complete, and she wants to achieve an average of at least 85, what is the lowest score Stevie can obtain for her final test?



Aiming for an A

—

14



- 14 A school gives grades in Mathematics each semester according to this table. Raj has scored the following results for four topics this semester, and has one topic to go: 75 68 85 79

- What is Raj's mean score so far?
- What grade will Raj get for the semester if his fifth score is:
 - 50?
 - 68?
 - 94?
- Find the maximum average score Raj can receive for the semester. Is it possible for him to get an A+?
- Find the least score that Raj needs in his fifth topic for him to receive an average of:
 - B+
 - A

Average score	Grade
90–100	A+
80–	A
70–	B+
60–	B
50–	C+
0–	C



Using a calculator 10F: Finding measures of centre

The activity can be found in the More Resources section of the Interactive Textbook in the form of a printable PDF.

10A

- 1 This spinner has six equally divided sections.
- a** List the sample space using the given numbers.
- b** Find:
- i** $\Pr(4)$ **ii** $\Pr(\text{not a } 4)$
iii $\Pr(4 \text{ or a } 5)$ **iv** $\Pr(\text{at most } 5)$



10A

- 2 A letter is randomly chosen from the word PROGRESS. Find the following probabilities.
- a** $\Pr(G)$ **b** $\Pr(S)$ **c** $\Pr(\text{not } S)$
d $\Pr(\text{vowel})$ **e** $\Pr(S \text{ or } R)$

10B

- 3 **a** Complete the following two-way table.

	A	Not A	Total
B	4		
Not B		7	11
Total		12	

- b** Use your two-way table to find the following probabilities.
- i** $\Pr(A)$ **ii** $\Pr(A \text{ and } B)$ **iii** $\Pr(B \text{ only})$ **iv** $\Pr(A \text{ or } B)$

10B

- 4 A survey of 20 people found that 8 people attended fitness classes and 12 people ran for fitness. 5 of these people did both.
- a** Construct a Venn diagram for the survey results.
- b** How many people:
- i** do not run?
ii run or attend a fitness class?
iii only attend a fitness class?
- c** If one of the 20 people was randomly selected, find:
- i** $\Pr(\text{run and attend a class})$
ii $\Pr(\text{neither run nor attend a class})$
iii $\Pr(\text{only run})$
- d** Turn your Venn diagram into a two-way table.

10C

- 5 A coin is tossed and then a 4-sided die is rolled.
- a** Copy and complete the table to list the sample space of this experiment.

	1	2	3	4
H				
T				

- b** How many possible outcomes are there?
- c** Find the probability of:
- i** the combination H4
ii tails on the coin and a factor of 6 on the die

10G Interpreting data from tables and graphs

Learning intentions

- To know the common types of statistical graphs including those that are skewed or symmetrical
- To be able to interpret common types of statistical graphs
- To be able to recognise when a graph may be misleading or drawn to give a false impression

Key vocabulary: histogram, dot plot, pie chart, symmetrical data, skewed data, mean, median, mode, range

In our everyday lives, it is important to be able to understand many forms of information. Data that is presented in a table or a graph is much easier to interpret than a long list of data. The headings in a table add detail and graphs give a visual comparison between values or categories.

Lesson starter: An unfair comparison

Each pair of graphs below shows the same data. Identify which one of the pair is misleading and discuss the reasons why.

Graph A1

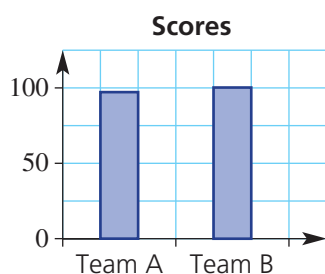

Graph A2

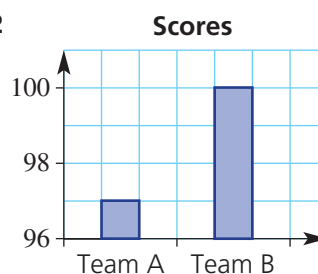

Graph B1

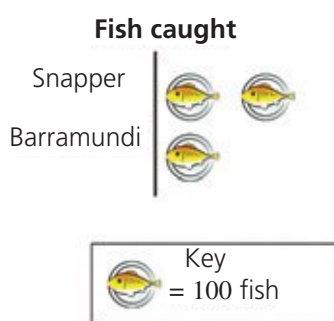

Graph B2

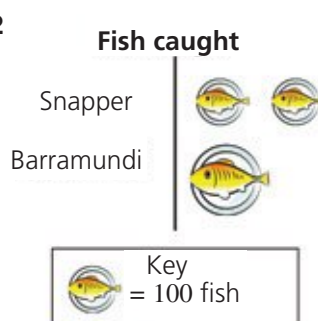

Graph C1

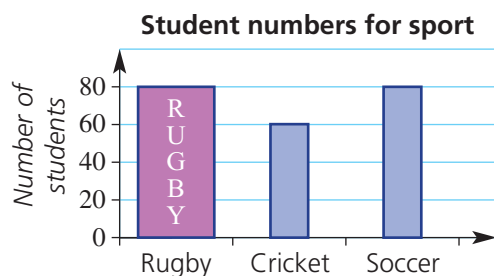

Graph C2

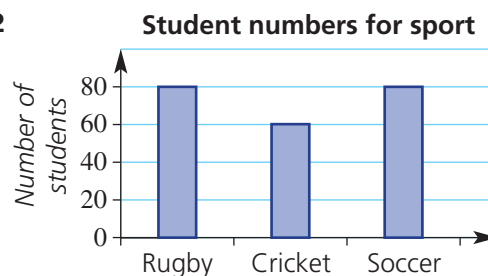

Key ideas

- Graphs can be presented in different forms. Some common examples are:

Histogram

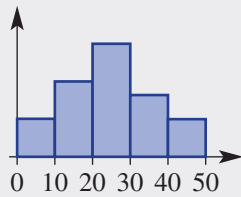

Column graph

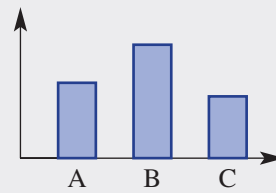

Dot plot



Pie chart

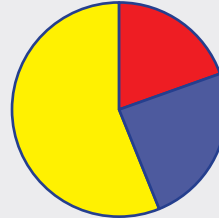

- The titles, scales and column heights or sector angles tell us something about the data that is used to make the graphs.
- Misleading graphs give a false impression about data.
 - When only part of the scale is shown, the difference between results may be exaggerated.
 - If one column has a different size or colour, it may appear to have greater value than the other columns.
 - When pictograph symbols are not the same size, the larger symbol appears to have a higher value.
 - A measure of centre can be misleading if it is not a fair representation of the centre of the data values.

For example, for the data in the graph below, the mean wage of \$850 is actually larger than all other wages except the outlier of \$2000. So the median (middle) wage of \$620 is a better representation of the 'average' wage in this case.

Weekly wages for a small business

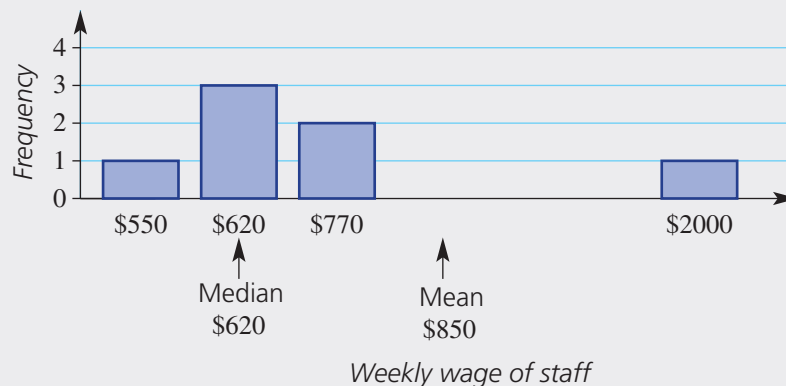

- Graphs can help to determine if data is symmetrical or skewed.

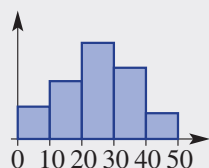
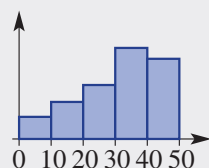
Symmetrical**Skewed**

- Symmetrical data** will appear like the data has a mirror line at its centre.
- Skewed data** will have values bunched to one side of the middle.

Exercise 10G

Understanding

1–3

2, 3

- Which of the following are not examples of graphs?
dot plot, mean, column graph, pie chart, range and histogram.
- Which of the following graphs is symmetrical and which is skewed?

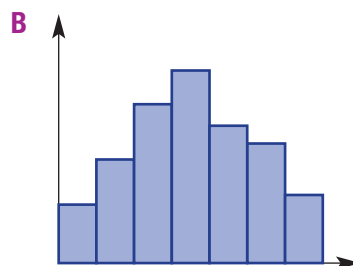
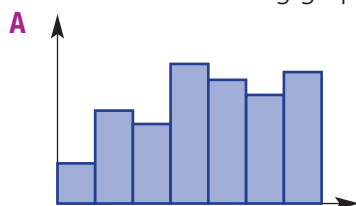

- Which of the two graphs might a newspaper use if it wanted to give the impression that the Panthers beat the Jaguars by a large margin? Give a reason.

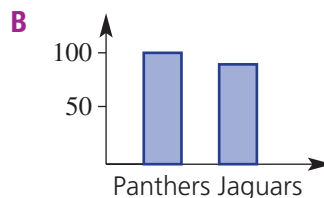
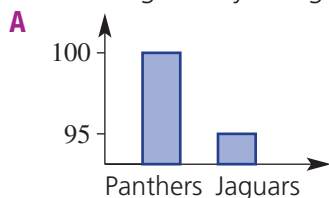

Fluency

4–6, 8, 9

4, 6, 7, 9, 10



Example 13 Interpreting histograms or column graphs

This column graph shows the results of a spelling test out of 10.

- How many results are shown in this histogram?
- List the results in ascending order.
- Calculate the mean.
- Calculate the median.
- What is the range of results from this test?
- Is this data skewed or symmetrical?
- What proportion of results is greater than or equal to 7?

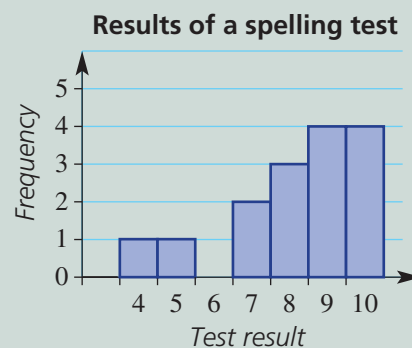

Continued on next page

Solution

a $1 + 1 + 2 + 3 + 4 + 4 = 15$

b 4, 5, 7, 7, 8, 8, 8, 9, 9, 9, 9, 10, 10, 10, 10

c Mean = $\frac{123}{15}$
= 8.2

d Median = 9

e Range = $10 - 4$
= 6

f Skewed

g $\frac{13}{15}$

Explanation

The frequency shows how many times each score occurred.

Add the frequency values to find the total number of scores.

1 lot of 4, 1 lot of 5, 2 lots of 7, 3 lots of 8, 4 lots of 9, 4 lots of 10.

$$4 + 5 + 7 + 7 + 8 + 8 + 8 + 9 + 9 + 9 + 9 + 10 + 10 + 10 + 10 = 123$$

The 8th score is the middle score.

The range is the highest score minus the lowest score.

Results are bunched to the higher scores.

13 scores are greater than or equal to 7 out of a total of 15 scores.

Now you try

This pie chart shows the proportion of households in a particular town that have a type of pet. There are 500 households in the town.

- a** How many of the households owned:
- i** dogs? **ii** cats? **iii** other?
- b** How many more households own cats compared to dogs?
- c** What is the sector angle for cats?

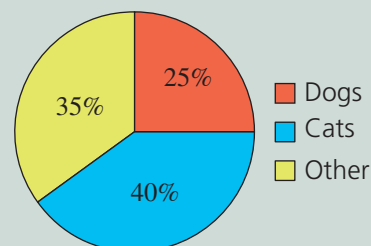

- 4** This graph shows the results of a number of maths tests out of 10.



- a** How many results are shown in this graph?
- b** List the results in ascending order.
- c** Calculate the mean.
- d** Calculate the median.
- e** What is the range of results from this test?
- f** Is this data skewed or symmetrical?
- g** What proportion (fraction) of results is greater than or equal to 8?

Results of a maths test

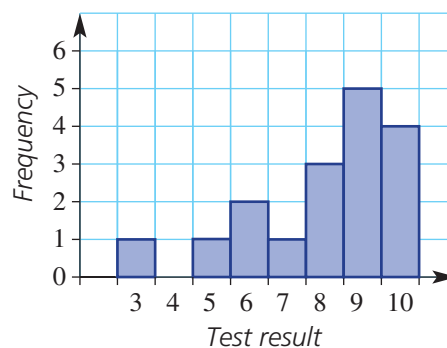



- 5 This dot plot shows the heights, in cm, of the students in a Year 9 class.

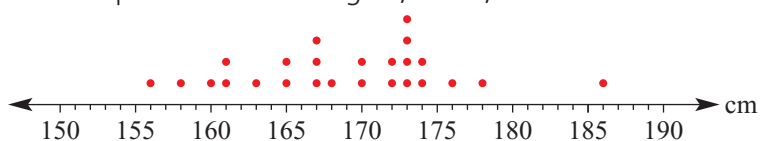

Hint: Each dot represents a student.



- How many students have their heights recorded on this dot plot?
- What is the range of heights?
- What is the mode of these heights?
- What is the median height for this class?
- What is the mean height for this class?
- What value is the outlier?



- 6 This pie chart shows the proportions of deaths in Australia from diseases caused by smoking.

Deaths from smoking-related diseases

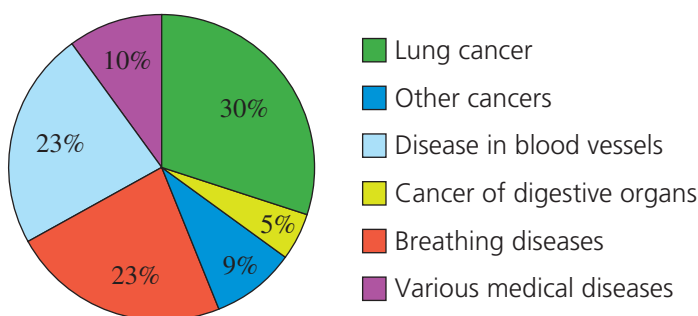

Around 15 000 Australians in total die from smoking-related illness per year.

- What is the total percentage of smoking deaths caused by cancer?
- How many Australian smokers die of cancer in a year?
- How many Australian smokers die of cancer each day? Round to the nearest whole number.
- How many Australian smokers die from various breathing diseases each day? Round to one decimal place.
- Calculate the sector angle for lung cancer. Recall that 100% represents 360° .

Hint: Number of deaths

$$= \frac{\text{percentage}}{100} \times \text{total deaths}$$

$$\text{Sector angle} = \text{percentage} \times 360^\circ$$



- 7 The following table shows tide times and heights in December for Yamba, on the NSW north coast. The tide heights shown are **red for low tide** and **blue for high tide**. The times are in 24-hour time.

Saturday 17		Sunday 18		Monday 19		Tuesday 20		Wednesday 21	
Time	Height	Time	Height	Time	Height	Time	Height	Time	Height
0038	1.14	0145	1.18	0255	1.26	0401	1.37	0502	1.49
0619	0.45	0729	0.49	0847	0.50	1008	0.46	1123	0.38
1243	1.42	1340	1.34	1445	1.26	1556	1.21	1703	1.18
1925	0.29	2018	0.29	2115	0.28	2211	0.26	2307	0.22

Write all time answers in both 24-hour time and 12-hour time.

- How high is the second high tide on Saturday 17 December?
- What time is the first low tide on Monday 19 December?
- How much later in the morning is the low tide on Tuesday 20 December than the low tide on Monday 19 December?
- What is the difference in height between the two high tides on Wednesday 21 December?
- How long is it between the two high tides on Sunday 18 December?

Hint: 1520 in 24-hour time is 3.20 p.m. in 12-hour time.



10G



- 8 The following is a table of life expectancy estimates for people in various countries.

Life expectancy in years			
Country	Overall average	Male	Female
Japan	83	79	86
Switzerland	82	80	84
Australia	81	79	84
Malaysia	74	72	77
Vietnam	74	72	77
Indonesia	71	69	73
Papua New Guinea	57	55	60
South Africa	49	49	50
Mozambique	39	38	39

- How many years more do Australian males expect to live compared to Mozambique males?
- How many years more do Australian females expect to live compared to Papua New Guinea females?
- If the overall world average of life expectancy is 67 years, how far above the average is Japan's overall average life expectancy?
- Find the increase in life expectancy between Indonesian males and Australian males. Now calculate this increase as a percentage of Indonesian male life expectancy. Round to one decimal place.



- 9 The line graphs below show the mean monthly minimum and maximum temperatures and also the monthly rainfall in mm for Hobart.

The temperature values are read from the scale on the left and the rainfall values are read from the scale on the right. For example, in January the mean maximum temperature is 22°C and the rainfall is 44 mm.

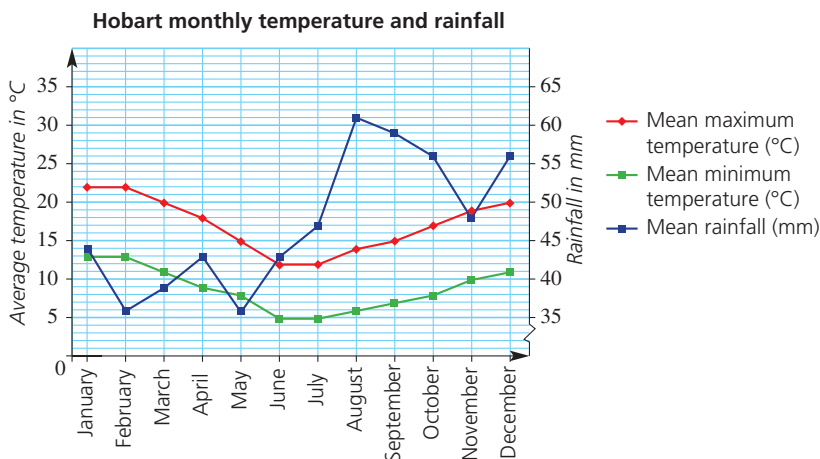

- What was the mean maximum temperature in April?
- What was the rainfall in April?
- What was the mean minimum temperature in July?
- What was the rainfall in July?
- During what months was the mean maximum temperature greater than 19°C ?
- During what months was the rainfall less than 40 mm per month?
- Which were the wettest two months in Hobart?
- What was the temperature range in December?



- 10 The following graph shows impact speeds (reaction time and distance travelled while braking) for cars when driving at various speeds on a dry road.

Hint: Reaction time is shown by the purple bar, braking time is shown by the orange bar.

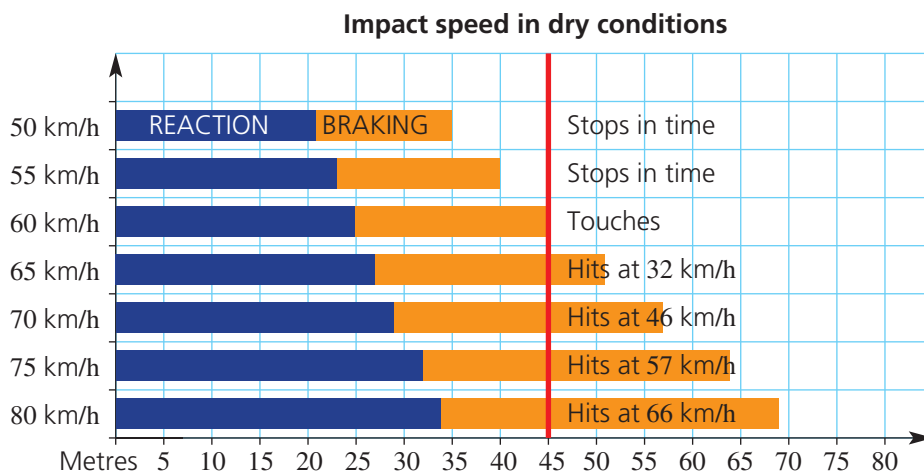

- The red line on the graph represents an object or person in front of the braking car. How far in front of the car is the object or person at the start of the driver's reaction time?
- How many metres are travelled during *reaction time* when driving at 60 km/h?
- How many metres are travelled during *braking time* when driving at 60 km/h?
- How much distance is needed, overall, to stop when driving at 80 km/h?
- By how much does the braking distance increase when driving at 80 km/h compared to 50 km/h?

Problem-solving and reasoning

11, 12

11, 13, 14

- 11 Here are two column graphs, each showing the same results of a survey that asked people which TV channel they preferred.

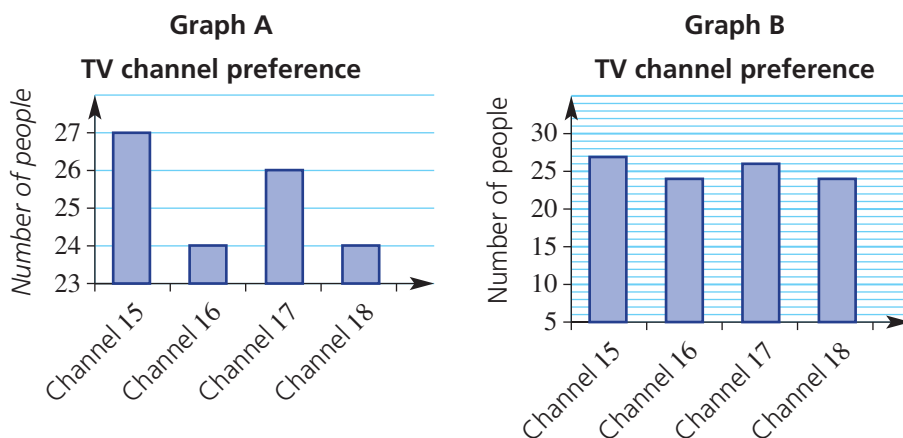

- From Graph A, write down how many viewers preferred each channel.
- Which graph could be titled 'Channel 15 is clearly most popular'?
- Which graph could be titled 'All TV channels have similar popularity'?
- What is the difference between the two graphs?
- Which graph is misleading, and why?

10G

12 This column graph shows the number of sales for one month of four popular breakfast cereals. The height of each column represents the sales.

- List the breakfast cereals in order of sales.
- Did Yum-crunch have more sales than the other cereals?
- List 3 changes that have been made to the Yum-crunch column to make it look like it has better sales than any of the other cereals.
- How should the columns be drawn so the graph is not misleading?

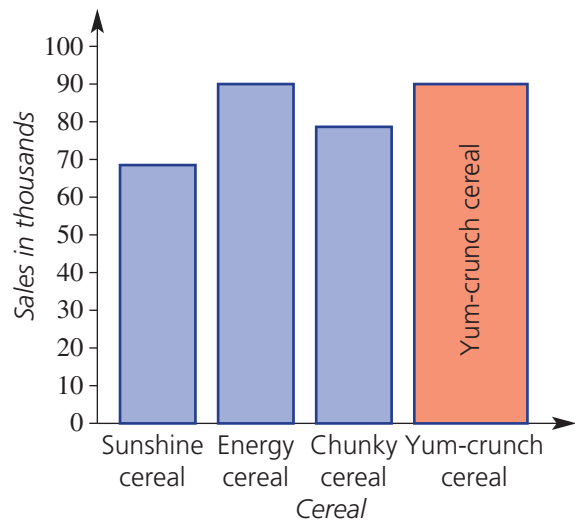

13 This pictograph shows the number of TV viewers for the final matches of various sports.

Size of TV audience for finals matches

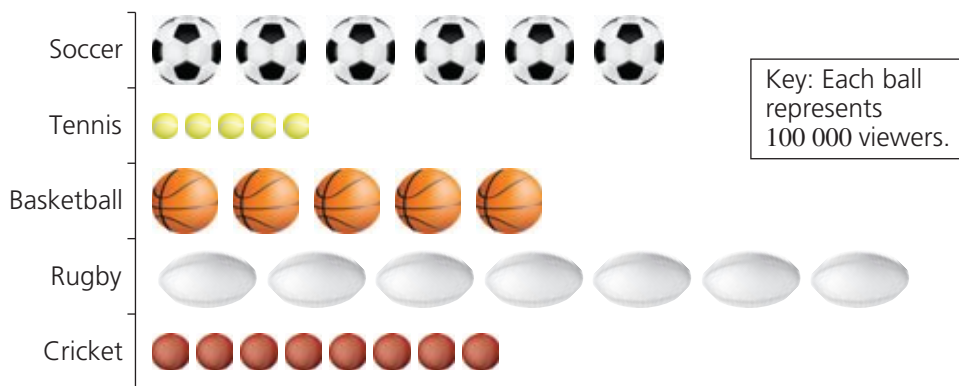

- Which sport *appears* to have had the greatest TV audience?
- List the sports in order, according to their *length* on the pictograph.
- Using the key, determine the audience sizes for the rugby and soccer finals.
- Which sport actually had the largest TV audience? What was the size of its audience?
- List the sports in order according to the audience size calculated using the key.
- In what way is this graph misleading?
- How should a pictograph be drawn so it is not misleading?





- 14 This column graph shows the price of some houses that were sold during one November in a Sydney suburb.

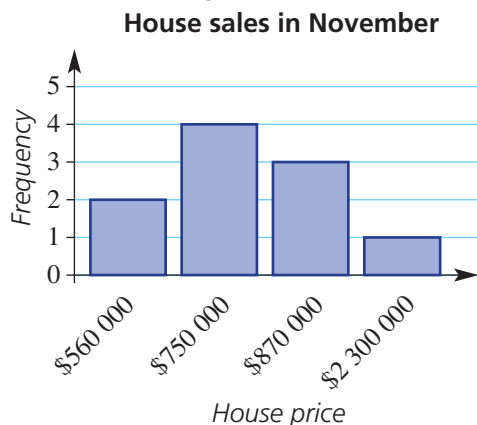

- How many house sales are shown in this column graph?
- List the price of each house in ascending order.
- Find the mean house price.
- Find the median house price.
- A newspaper headline read 'House prices now average over \$900 000'. Is this 'average' referring to the mean or median price?
- What proportion of house prices were less than the mean value?
- Do you think the mean or the median would better represent the 'average' house price? Give a reason for your answer.



Viewing distance for TV

—

15

- 15 a Draw a line graph showing the Minimum and Maximum viewing distances for each TV screen size. Include a key.

TV screen size (length of diagonal in inches)	Maximum viewing distance (cm)	Minimum viewing distance (cm)
26	200	100
30	220	120
34	260	130
42	320	160
47	360	180
50	380	200
55	420	220
60	470	230
65	490	250

- If a lounge chair is 1.5 m in front of the TV, which sizes of TV would be suitable?
- If a lounge chair is 3 m in front of the TV, which sizes of TV would be suitable?

10H Stem-and-leaf plots

Learning intentions

- To be able to construct and interpret a stem-and-leaf plot
- To be able to construct and interpret a back-to-back stem-and-leaf plot
- To be able to interpret the shape of a stem-and-leaf plot to describe the distribution of the data as symmetrical or skewed

Key vocabulary: stem-and-leaf plot, symmetrical data, skewed data, back-to-back stem-and-leaf plot

Stem-and-leaf plots (or stem plots) are commonly used to display a single data set or two related data sets. They help to show how the data is distributed. They retain all the individual data elements so no detail is lost. The median and mode can be easily read from a stem-and-leaf plot because all the data sits in order.

→ Lesson starter: Ships vs Chops

At a school, Ms Ships' class and Mr Chops' class sit the same exam. The scores are displayed using this back-to-back stem-and-leaf plot. Discuss the following.

- Which class had the most students?
- What were the lowest and highest scores from each class?
- What were the median scores from each class?
- Which class could be described as symmetrical and which as skewed?
- Which class had the better results?

Leaf Ms Ships' class	Stem	Leaf Mr Chops' class
3 1	5	0 1 1 3 5 7
8 8 7 5	6	2 3 5 5 7 9 9
6 4 4 2 1	7	8 9 9
7 4 3	8	0 3
6	9	1

7 | 8 means 78



Key ideas

- A **stem-and-leaf plot** uses a stem number and leaf number to represent data.
 - The data is shown in two parts: a stem and a leaf.
 - The 'key' tells you how the plot is to be read.

Ordered stem-and-leaf plot

Stem	Leaf
1	2 6
2	2 3 4 7
3	1 2 4 7 8 9
4	2 3 4 5 8
5	7 9

The leaf numbers are written in order.

A Key is added to show the place value of the stems and leaves.

2 | 4 means 24 people

- **Back-to-back stem-and-leaf plots** can be used to compare two sets of data. The stem is drawn in the middle, with the leaves on either side.

Scores for the last 30 football games

	Winning scores		Losing scores
81 lowest winning score		7	4 5 8 8 9
	1	8	0 0 3 3 6 7
	7 5	9	1 2 3 6
Symmetrical data	8 4 4 1	10	3 9
	9 5 0	11	1
	3 1	12	

10 | 9 means 109

111 highest losing score

Skewed data

- **Symmetrical data** will produce a graph that is symmetrical about the centre.
- **Skewed data** will produce a graph that includes data bunched to one side of the centre.

Exercise 10H

Understanding

1-3

3

- 1 List the statistical data that would produce these stem-and-leaf plots. Use the key to help.

a

Stem	Leaf
3	5 7
4	1 3 8

3 | 1 means 3.1

b

Stem	Leaf
5	2
6	0 1 7
7	3 5

6 | 3 means 63

Hint: The same stem goes with each leaf along each row.



10H

- 2 This stem-and-leaf plot shows the number of minutes Alexis spoke on her phone for a number of calls.

Stem	Leaf
0	8
1	5 9
2	1 1 3 7
3	4 5

2 | 1 means 21 minutes

- a How many calls are represented by the stem-and-leaf plot?
 b What is the length of the:
 i shortest phone call?
 ii longest phone call?
 c What is the mode (the most common) call time?
 d What is the median call time (middle value)?
- 3 This back-to-back stem-and-leaf plot shows the thickness of tyre tread on a selection of cars from the city and country.

City		Country
8 7 3 1 0 0 0	0	6 8 8 9
8 6 3 1 0	1	0 4 5 5 6 9
	2	3 4 4

1 | 3 means 13 mm

- a How many car tyres were tested altogether?
 b What was the smallest tyre tread thickness in:
 i the city?
 ii the country?
 c What was the largest tyre tread thickness in:
 i the city?
 ii the country?
 d Find the median tyre tread thickness for tyres in:
 i the city
 ii the country
 e Is the distribution of tread thickness for city cars more symmetrical or skewed?
 f Is the distribution of tread thickness for country cars more symmetrical or skewed?



Hint: Count the leaves to find the number of calls.



Hint: 06 is written just as 6.



Hint: Skewed distributions are not symmetrical.



Fluency

4(1/2), 5, 6

4(1/2), 6, 7



Example 14 Constructing and using a stem-and-leaf plot

For this set of data:

0.3 2.5 4.1 3.7 2.0 3.3 4.8 3.3 4.6 0.1 4.1 7.5 1.4 2.4
 5.7 2.3 3.4 3.0 2.3 4.1 6.3 1.0 5.8 4.4 0.1 6.8 5.2 1.0

- a Organise the data into an ordered stem-and-leaf plot.
 b Find the median.
 c Find the mode.
 d Describe the data as symmetrical or skewed.

Solution

Stem	Leaf
0	1 1 3
1	0 0 4
2	0 3 3 4 5
3	0 3 3 4 7
4	1 1 1 4 6 8
5	2 7 8
6	3 8
7	5

3 | 4 means 3.4

Explanation

The minimum is 0.1 and the maximum is 7.5 so stems range from 0 to 7.

Place leaves in order from smallest to largest. Some numbers appear more than once; e.g. two instances of 0.1 means that the leaf 1 appears twice: 0.1, 0.1, ...

$$\begin{aligned} \text{b Median} &= \frac{3.3 + 3.4}{2} \\ &= 3.35 \end{aligned}$$

There are 28 data values. The median is the average of the two middle values (the 14th and 15th values).

c Mode is 4.1.

The most common value is 4.1.

d Data is approximately symmetrical.

The distribution of numbers is approximately symmetrical about the stem containing the median.

Now you try

For this set of data:

24 37 52 16 11 29 13 26
34 42 9 29 21 35 46 50

- Organise the data into an ordered stem-and-leaf plot.
- Find the median.
- Find the mode.
- Describe the data as symmetrical or skewed.

- 4 For each of the following data sets:
- organise the data into an ordered stem-and-leaf plot
 - find the median
 - find the mode
 - describe the data as symmetrical or skewed

a 41 33 28 24 19 32 54 35
19 23 32 26 28 26 28

b 31 33 23 35 15 23 48 50 35 42 45 15 21
51 31 34 23 42 50 26 30 45 37 39 45

c 34.5 34.9 33.7 34.5 35.8 33.8 34.3 35.2 37.0 34.7
35.2 34.4 35.5 36.5 36.1 33.3 35.4 32.0 36.3 34.8

d 167 159 159 193 161 164 167 157 158 175 177 185
177 202 185 187 159 189 167 159 173 198 200

Hint: Draft version: Enter the leaves in the same order as in the question.
Final version: Rewrite the stem-and-leaf plot with leaves in order. Remember to include the key.



Hint: In part d, use 16 as the stem for 167.



10H

- 5 The number of vacant rooms in a motel each week over a 20-week period is shown below.
- 12 8 11 10 21 12 6 11 12 16
14 22 5 15 20 6 17 8 14 9
- Draw a stem-and-leaf plot of this data.
 - In how many weeks were there fewer than 12 vacant rooms?
 - Find the median number of vacant rooms.



Example 15 Constructing back-to-back stem-and-leaf plots

A shop owner has two jeans shops. The daily sales in each shop over a 16-day period are monitored and recorded as follows.

Shop A

3 12 12 13 14 14 15 15 21 22 24 24 24 26 27 28

Shop B

4 6 6 7 7 8 9 9 10 12 13 14 14 16 17 27

- Draw a back-to-back stem-and-leaf plot.
- Compare and comment on differences between the sales made by the two shops.

Solution

Explanation

Shop A		Shop B
3	0	4 6 6 7 7 8 9 9
5 5 4 4 3 2 2	1	0 2 3 4 4 6 7
8 7 6 4 4 4 2 1	2	7
1 3 means 13		

The data for each shop is already ordered. Stems are in intervals of 10. Record leaf digits for Shop A on the left and Shop B on the right, ordered from the middle to the outside.

- Shop A sales are generally between 12 and 28, with one low value of 3. Shop B sales are generally between 4 and 17, with one high value of 27. Shop A has a lot more high values than Shop B. Shop B has more low values than Shop A.

Look at both sides of the plot for the highest and lowest values and whether there are a few or many of the small and large numbers.

Now you try

At a school, two reading classes in year 6 read books for homework one night. The number of pages read by the students are recorded as follows.

Class A 21 36 19 15 19 31 17 24 29
Class B 3 16 14 20 11 18 12 13

- Draw a back-to-back stem-and-leaf plot.
- Compare and comment on the differences between the amount of reading completed by the different class groups.



- 6 For each of the following sets of data:
- Draw a back-to-back stem-and-leaf plot.
 - State the smallest and largest value in each set and compare the numbers of small and large values in each set.

a Set A: 46 32 40 43 45 47 53
33 48 39 43 54 40 54

Set B: 48 49 31 40 43 47 48
44 46 53 44 41 49 51

b Set A: 0.7 0.8 1.4 8.8 9.1 2.6 3.2 0.3 1.7 1.9 2.5 4.1 4.3 3.3 3.4
3.6 3.9 3.9 4.7 1.6 0.4 5.3 5.7 2.1 2.3 1.9 5.2 6.1 6.2 8.3

Set B: 0.1 0.9 0.6 1.3 0.9 0.1 0.3 2.5 0.6 3.4 4.8 5.2 8.8 4.7 5.3
2.6 1.5 1.8 3.9 1.9 0.1 0.2 1.2 3.3 2.1 4.3 5.7 6.1 6.2 8.3

Hint: Order the leaves with the smallest on the inside and largest on the outside. State whether each set has a few or many of the small numbers and large numbers.

- 7 a Draw a back-to-back stem-and-leaf plot for the final scores of St Kilda and Collingwood in the 24 AFL games given here.

St Kilda: 126 68 78 90 87 118
88 125 111 117 82 82
80 66 84 138 109 113
122 80 94 83 106 68

Collingwood: 104 80 127 88 103 95
78 118 89 82 103 115
98 77 119 91 71 70
63 89 103 97 72 68

- In what percentage of their games did each team score more than 100 points?
- Comment on the symmetry of the distribution of the scores for each team.
- Which team has scores that are more consistent?
Which team has more higher scores?

Hint: Percentage = fraction $\times 100$



Problem-solving and reasoning

8, 9

8–10

- 8 This stem-and-leaf plot shows the time taken, in seconds, by Helena to run 100 m in her last 25 races.

Stem	Leaf
14	9
15	4 5 6 6 7 7 7 8 9
16	0 0 1 1 2 2 3 4 4 5 5 7 7
17	2

14 | 9 means 14.9 seconds

- Find Helena's median time.
- What is the difference between the slowest and fastest time?
- If in her 26th race her time was 14.8 seconds and this was added to the stem-and-leaf plot, would her median time change? If so, by how much?

10H

- 9 Two brands of batteries were tested to determine their lifetime in hours. The data below shows the lifetime of 20 batteries of each brand.

Brand A: 7.3 8.2 8.4 8.5 8.7 8.8 8.9 9.0 9.1 9.2
9.3 9.4 9.4 9.5 9.5 9.6 9.7 9.8 9.9 9.9

Brand B: 7.2 7.3 7.4 7.5 7.6 7.8 7.9 7.9 8.0 8.1
8.3 9.0 9.1 9.2 9.3 9.4 9.5 9.6 9.8 9.8

Hint: The stems will be the 'units' value and each leaf the 'tenths' value.



- a Draw a back-to-back stem-and-leaf plot for this data.
b How many batteries from each brand lasted more than 9 hours?
c Which brand shows the best performance?

- 10 Find the median if all the data in each back-to-back stem-and-leaf plot was combined.

a

5	3	8 9
9 7 7 1	4	0 2 2 3 6 8
8 6 5 2 2	5	3 3 7 9
7 4 0	6	1 4
4 2 means 42		

Hint: First combine each back-to-back plot into just one stem-and-leaf plot.



b

3	16	0 3 3 6 7 9
9 6 6 1	17	0 1 1 4 8 8
8 7 5 5 4 0	18	2 2 6 7
2	19	0 1
16 3 means 16.3		



Birth weights and smoking

11

- 11 The back-to-back stem-and-leaf plot below shows the birth weight in kilograms of babies born to mothers who do or don't smoke.

Birth weight of babies

Smoking mothers		Non-smoking mothers
4 3 2 2	2	4
9 9 8 7 6 6 5 5	2*	8 9
4 3 2 1 1 1 0 0 0	3	0 0 1 2 2 3
6 5 5	3*	5 5 5 6 6 7 7 8
1	4	
	4*	5 5 6
2 4 means 2.4 kg		
2* 5 means 2.5 kg		



- a What percentage of babies born to smoking mothers have a birth weight of less than 3 kg?
b What percentage of babies born to non-smoking mothers have a birth weight of less than 3 kg?
c Compare and comment on the differences between the birth weights of babies born to mothers who smoke and those born to mothers who don't smoke.

101 Grouped data

Learning intentions

- To be able to construct a frequency table from a set of data including a percentage frequency column
- To be able to construct and analyse a histogram or percentage frequency histogram

Key vocabulary: frequency table, percentage frequency histogram, histogram, class interval

For some data, especially large sets, it makes sense to group the data and then record the frequency for each group to produce a frequency table. For numerical data, a graph generated from a frequency table gives a histogram. Like a stem-and-leaf plot, a histogram shows how the data is distributed across the full range of values. A histogram, for example, is used to display the level of exposure of the pixels in an image in digital photography. It uses many narrow columns to show how the light values are distributed across the scale from black to white.



→ Lesson starter: Baggage check

This histogram shows the distribution of the weight of a number of bags checked at an airport.

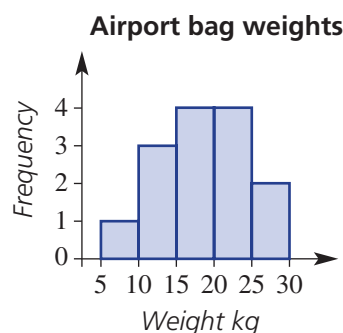

- How many bags had a weight in the range 10–15 kg?
- How many bags were checked in total?
- Is it possible to determine the exact mean, median or mode of the weight of the bags by looking at the histogram? Discuss.
- Describe the distribution of checked bag weights for the given graph.

Key ideas

- A **frequency table** shows the number of values within a set of categories or **class intervals**.
- Grouped numerical data can be illustrated using a **histogram**.
 - The height of a column corresponds to the frequency of values in that class interval.
 - There are usually no gaps between columns.
 - The scales are evenly spread, with each bar spreading across the boundaries of the class interval.
 - A **percentage frequency histogram** shows the frequencies as percentages of the total.
- Like a stem-and-leaf plot, a histogram shows whether the data is skewed or symmetrical.

Frequency table

Class interval	Frequency	Percentage frequency
60–	3	12
65–	4	16
70–	6	24
75–	8	32
80–85	4	16
Total	25	100

70– includes numbers from 70 to less than 75.

Frequency histogram

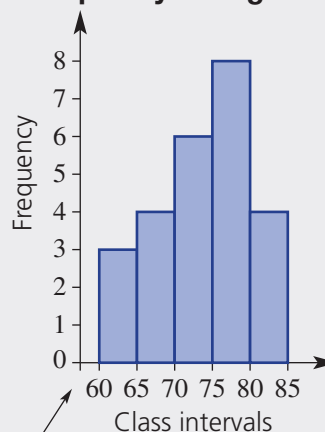

This gap may be used when the intervals do not start at zero.

Percentage frequency histogram

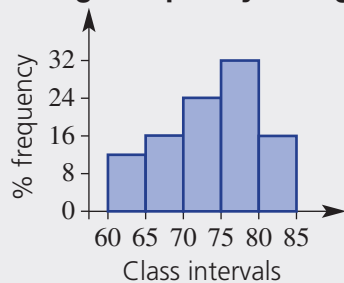

Exercise 10I

Understanding

1–4

4

- 1 Write the missing word for each of these statements.
 - a A group of scores such as 10 – 15 kg is called a _____.
 - b A _____ table shows the class intervals and the number of values in each class interval.
 - c A column graph that shows frequencies and scores is called a _____.
 - d A _____ histogram shows each frequency as a percentage of the total number of scores.

- 2 Write the total number of scores in each of these displays.

a

Class interval	Frequency
0–	3
5–	5
10–	8
15–	4

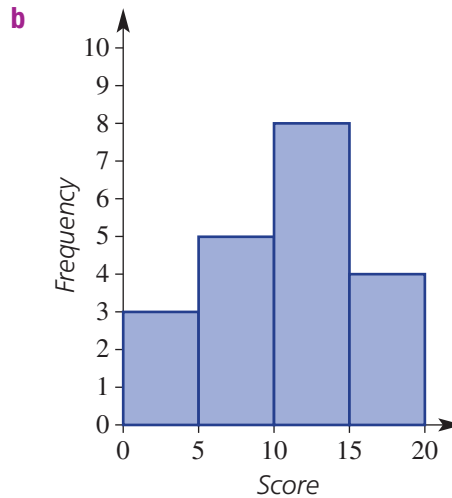

Hint: The sum of the frequencies equals the number of scores.



- 3 The frequency histogram below shows the number of years for which the number of international visitors to South Australia was within a given range for the decade from 2000 to 2009.



Hint: The frequency shows the number of years.



- a** How many years in the decade were there less than 330 000 international visitors?
b Which range of visitor numbers had the highest frequency?

- 4 Some Year 9 students selected a sample of textbooks from the library and recorded the number of pages in each book. The frequency histogram below shows their results.

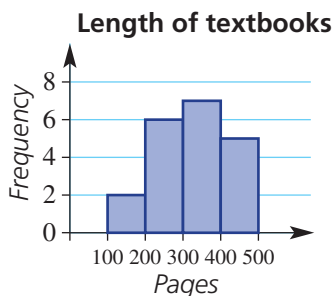

- a** How many textbooks had between 100 and 200 pages?
b How many textbooks were selected from the library?
c What percentage of textbooks had between:
i 200 and 300 pages? **ii** 200 and 400 pages?

Hint: The frequency shows the number of textbooks.
 Percentage = $\frac{\text{frequency}}{\text{total}} \times 100$





Example 16 Constructing frequency tables and histograms

The data below shows the number of hamburgers sold each hour by a 24-hour fast-food store during a 50-hour period.

1 10 18 14 20 11 19 10 17 21
 5 16 7 15 21 15 10 22 11 18
 12 12 3 12 8 12 6 5 14 14
 14 4 9 15 17 19 6 24 16 17
 14 11 17 18 19 19 19 18 18 20

- a** Set up and complete a grouped frequency table, using class intervals 0–, 5–, 10–, etc. Include a percentage frequency column.
- b** Construct a frequency histogram.
- c** For how many hours did the fast-food store sell:
- i** fewer than 10 hamburgers? **ii** at least 15 hamburgers?

Solution

a

Class interval	Frequency	Percentage frequency
0–	3	6
5–	7	14
10–	15	30
15–	19	38
20–24	6	12
Total	50	100

Explanation

Create class intervals of 5 from 0 up to 25, since 24 is the maximum number. Record the number of data values in each interval in the frequency column. Convert to a percentage by dividing by the total (50) and multiplying by 100.

b **Hamburger sales**

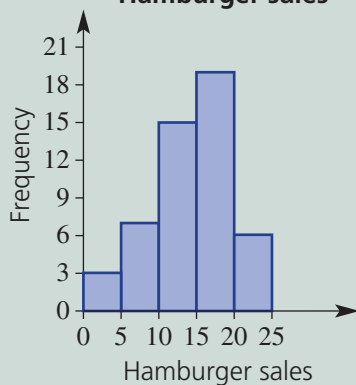

Create a frequency histogram with frequency on the vertical axis and the class intervals on the horizontal axis. The height of the column shows the frequency of that interval.

c i $3 + 7 = 10$ hours

Fewer than 10 hamburgers covers the 0–4 and 5–9 intervals.

ii $19 + 6 = 25$ hours

At least 15 hamburgers covers the 15–19 and 20–24 intervals.

Now you try

The data below shows the number of cars sold each month at a large city car yard.

18 26 31 12 52 46
38 19 24 40 57 54

- Set up and complete a grouped frequency table, using class intervals 0–, 5–, 10–, etc. Include a percentage frequency column.
- Construct a frequency histogram.
- For how many months did the car yard sell more than 50 cars?
- What percentage of months were less than 20 cars sold?

- 5** The data below shows the number of ice creams sold from an ice cream van over a 50-day period.

0 5 0 35 14 15 18 21 21 36 45 2 8
2 2 3 17 3 7 28 35 7 21 3 46 47
1 1 3 9 35 22 7 18 36 3 9 2
11 37 37 45 11 12 14 17 22 1 2 2

- Set up and complete a grouped frequency table using class intervals 0–, 10–, 20– etc. Include a percentage frequency column.
- Construct a frequency histogram.
- How many days did the ice cream van sell:
 - fewer than 20 ice creams?
 - at least 30 ice creams?
- What percentage of days were 20 or more ice creams sold?

Hint: The interval '0–' means scores from 0 to 9.



Hint: 'Fewer than 20' doesn't include 20. 'At least 30' includes 30.



- 6** The data below shows the mark out of 100 on the Science exam for 60 Year 9 students.

50 67 68 89 82 81 50 50 89 52 60 82 52 60 87
89 71 73 75 83 86 50 52 71 80 95 87 87 87 74
60 60 61 63 63 65 82 86 96 88 50 94 87 64 64
72 71 72 88 86 89 69 71 80 89 92 89 89 60 83

- Set up and complete a grouped frequency table, using class intervals 50–, 60–, 70– etc. Include a percentage frequency column.
- Construct a frequency histogram.
- How many marks were less than 70 out of 100?
 - What percentage of marks were at least 70 out of 100?

Hint: The frequency for '50–' will be the number of scores from 50 to 59.



- 7** The number of goals kicked by a country footballer in each of his last 30 football matches is given below.

8 9 3 6 12 14 8 3 4 5 2 5 6 4 13
8 9 12 11 7 12 14 10 9 8 12 10 11 4 5

- Organise the data into a grouped frequency table using class intervals of 0–2, 3–5 etc.
- Draw a frequency histogram for the data.
- In how many games did the player kick fewer than six goals?
- In how many games did he kick more than 11 goals?

Hint: The frequency for '0–2' will be the number of scores that are 0, 1 or 2. Label the horizontal scale 0, 3, 6, 9 etc.



- 8 Which one of these histograms illustrates a symmetrical data set and which one shows a skewed data set?

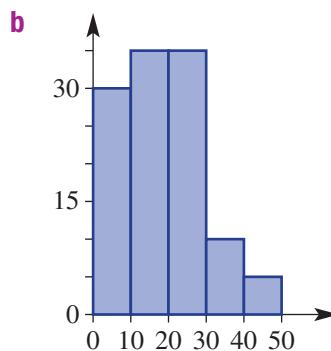
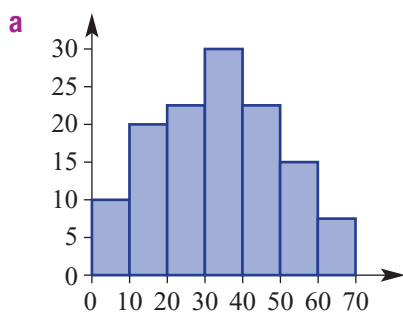

Hint: Skewed data is bunched either below or above the middle.



Problem-solving and reasoning

9–11

9, 11, 12

- 9 Write down the missing numbers in these frequency tables; i.e. find the values of the pronumerals.

a

Class interval	Frequency	Percentage frequency
0–4	1	10
5–9	3	c
10–14	4	d
a –19	b	e
Total	10	f

b

Class interval	Frequency	Percentage frequency
40–	20	20
a –	28	b
60–	12	c
70–	d	40
Total	100	e

- 10** The data below shows the length of overseas phone calls (in minutes) made by a particular household over a six-week period.

1.5 1 1.5 1 4.8 4 4 10.1 9.5 1 3
 8 5.9 6 6.4 7 3.5 3.1 3.6 3 4.2 4.3
 4 12.5 10.2 10.3 4.5 4.5 3.4 3.5 3.5 5 3.5
 3.6 4.5 4.5 12 11 12 14 14 12 13 10.8
 12.1 2.4 3.8 4.2 5.6 10.8 11.2 9.3 9.2 8.7 8.5

Hint: Percentage = $\frac{\text{frequency}}{\text{total}} \times 100$



What percentage of phone calls were more than 3 minutes in length? Answer to one decimal place.

- 11** This percentage frequency histogram shows the heights of office towers in a city.

- a** What percentage of office towers have the following heights?

- i** between 50 m and 100 m
- ii** less than 150 m
- iii** no more than 200 m
- iv** at least 100 m
- v** between 100 m and 150 m or greater than 200 m

- b** If the city had 100 office towers, how many would have a height of:

- i** between 100 m and 150 m?
- ii** at least 150 m?

- c** If the city had 40 office towers, how many would have a height of:

- i** between 0 m and 50 m?
- ii** no more than 150 m?

Hint: In parts **b** and **c**,
number of office towers =
percentage \times total

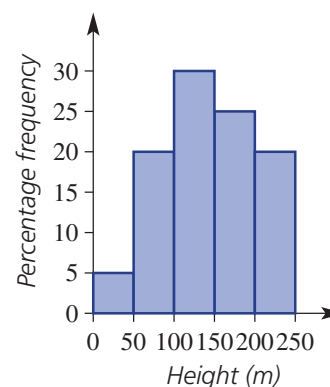

- 12 Two students show different histograms for the same set of data.

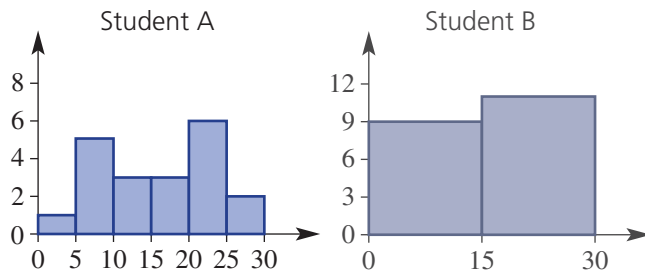

Hint: A histogram that shows a lot of detail is more useful.



- a Which histogram is more useful in helping to analyse the data?
 b What would you advise student B to do differently when constructing the histogram?



The distribution of weekly wages

—

13

- 13 The data below shows the weekly wages of 50 people in dollars.

400 500 552 455 420 424 325 204 860 894 464 379 563
 940 384 370 356 345 380 720 540 654 678 628 656 670
 740 750 730 766 760 700 700 768 608 576 890 920 874
 450 674 725 612 605 600 548 670 230 725 860

- a What is the minimum weekly wage and the maximum weekly wage?
 b i Organise the data into about 10 class intervals: 200–, 300– etc.
 ii Draw a frequency histogram for the data.
 c i Organise the data into about five class intervals.
 ii Draw a frequency histogram for the data.
 d Discuss the shapes of the two graphs. Which graph represents the data better and why?



Using a calculator 10I: Graphing grouped data

The activity can be found in the More Resources section of the Interactive Textbook in the form of a printable PDF.





Maths@Work: Personal trainer

Personal training is a growing trend in our society. Personal trainers, while being fit themselves, must have an understanding of mathematics. The mathematics involved in personal training includes calculations of body mass index (BMI) using body mass and weight, calories and kilojoules, business-related mathematics and clients' pulse rates.



- Calculate the mean pulse rate (measured in beats per minute, bpm) for each of the following clients, over their first five training sessions. Round to a whole number of bpm.
 - 85, 92, 86, 90, 88
 - 78, 90, 79, 82, 91
 - 98, 100, 102, 94, 98
 - 120, 122, 134, 116, 104
- The resting heart rate of a person aged from 6 to 15 is 70 bpm to 100 bpm. Decide if each of the following children aged between 6 and 15 years has a healthy resting heart rate.
 - Ella 88 bpm
 - Caleb 102 bpm
 - Whitney 72 bpm
 - Mia 120 bpm
 - Kevin 92 bpm
- As a personal trainer, monitoring a client's resting pulse rate over time is important. Luke's resting pulse rates are displayed in the following stem-and-leaf plot. Find the mean, mode, median and range to one decimal place of Luke's resting heart rates for the month of February.

Resting heart rate in bpm

Stem	Leaf
7	8 9
8	2 4 4 6 7 8 8
9	0 0 0 1 3 4 5 5 8 8 9
10	4 5 6 6 7 9
11	0 3

8|4 means 84

- 4 A personal trainer needs to be able to compare resting pulse rates to pulse rates after exercise. Look at the back-to-back stem-and-leaf plot below for Luke, and find the mean, mode and median bpm after exercise and compare to Question 3.

Heart rate in bpm

Leaf (after exercise)	Stem	Leaf (resting)
8 6 4	7	8 9
6 6 5	8	2 4 4 6 7 8 8
9 8 8 8 8 7 6	9	0 0 0 1 3 4 5 5 8 8 9
6 6 5 4	10	4 5 6 6 7 9
8 6 2	11	0 3
7 6 6 5 4	12	
3 2 2	13	

Using technology

- 5 Wal, a personal fitness trainer, keeps a monthly record of the PBs (personal best times) for his clients. One popular routine is performing the following three exercises:
- 20 step-ups
 - 10 burpees
 - 10 squats.

Here is a list of PBs, in seconds, for Wal’s clients when doing this routine one October.

94 63 103 84 98 89 73 105 85 115
 77 96 87 107 64 90 88 102 91 78
 99 119 82 76 82 71 83 80 92 117

Enter these 30 times into a graphics calculator and construct a histogram using interval widths of 10, starting with 60 seconds.

Note: Refer to the PDF in the More Resources section of the Interactive Textbook, which has instructions for graphing grouped data using a graphics calculator.



The missing data

Gregory is a marine biologist and is collecting and analysing data regarding shark and dolphin numbers in a particular area of the Great Barrier Reef.

He collects data for 14 consecutive days, but unfortunately two pieces of data (D_1 and D_2) are lost due to a computer glitch as shown in the table below.

Day	1	2	3	4	5	6	7	8	9	10	11	12	13	14
Sharks	15	12	4	D_1	15	11	19	5	1	10	12	6	24	11
Dolphins	4	7	2	3	2	6	4	2	D_2	4	7	2	4	6

Present a report for the following tasks and ensure that you show clear mathematical workings and explanations where appropriate.

Preliminary task

- If Gregory assumes that $D_1 = 10$, find the following:
 - The mean and median number of sharks recorded, correct to one decimal place where necessary.
 - The range for the number of sharks recorded over the two weeks.
- If Gregory assumes that $D_2 = 5$, find the following:
 - The mean and median number of dolphins recorded, correct to one decimal place where necessary.
 - The range for the number of dolphins recorded over the two weeks.
- Which set of data for the two species (sharks or dolphins) appears to be more inconsistent and spread out?

Modelling task

The problem is to determine the possible of D_1 and D_2 so that Gregory can complete the report based on the statistics he can remember.

- Write down all the relevant information that will help solve this problem, and illustrate using diagrams.
-
- Gregory seems to remember that the range for the number of dolphins was 7. Determine the value of D_2 assuming Gregory remembers the range correctly.
 - From his memory, Gregory thought that the mean number of sharks over the 14 day period was approximately 12. Based on this value, determine the likely value of D_1 .
 - From his memory, Gregory thought that the mean number of dolphins over the 14-day period was approximately 5. Based on this value, determine the likely value of D_2 .
 - If the median number of sharks was 11, find the possible value(s) of D_1 .



- f** If in fact the mean number of dolphins over the 14-day period was 4 after rounding to the nearest integer, find all possible values of D_2 .
- g** If the mean of the first 7 days was the same as the mean of the next 7 days for the dolphin data collected, determine the value of D_2 .
- h** Is it possible for the mean of the first 7 days to be the same as the mean of the next 7 days for the shark data collected? Give reasons.
- i** Summarise your results, showing the calculations that lead to each possible value of D_1 and D_2 and decide which values you believe are mostly likely to represent the missing data.

Evaluate
and
verify

Communicate

Extension questions

- a** Draw a dot plot for each species and decide on a set of likely values for D_1 and D_2
- b** Decide if it is possible for the median of either set of data to be anything other than an integer. If so, determine the values of D_1 and D_2 to allow this to happen.
- c** Estimate the probability on any given day the shark numbers exceed 12 at the area of the reef Gregory is studying?



- 1 One coin says to another coin: *How does my face appear?*

Answer these questions for each scenario, then match the letter in bold to the answers listed below to find the answer to the riddle.

2 coins are tossed 12 times

$$\Pr(\text{HH}) = \mathbf{D}$$

$$\Pr(\text{HT or TH}) = \mathbf{I}$$

$$\text{Expected number of TT} = \mathbf{R}$$

$$\text{Expected number of one or more Tails} = \mathbf{T}$$

1 die is tossed 12 times

$$\Pr(5) = \mathbf{A}$$

$$\Pr(\text{greater than 2}) = \mathbf{N}$$

$$\text{Expected number of 6s} = \mathbf{S}$$

Choosing one letter from the word PUZZLES

$$\Pr(Z) = \mathbf{M}$$

$$\Pr(\text{consonant}) = \mathbf{O}$$

		,								
$\frac{1}{2}$	9	2	3	$\frac{1}{6}$	$\frac{2}{3}$	$\frac{1}{4}$	$\frac{5}{7}$	$\frac{2}{7}$		

- 2 Match each description (1–5) with the most suitable diagram (A–E). Note: There is only one description for each diagram.

- 1 Don't own an iPhone
- 2 Own an iPhone only
- 3 Own both an iPod and an iPhone
- 4 Own an iPod or an iPhone or both
- 5 Own an iPod

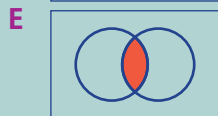
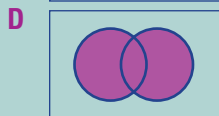
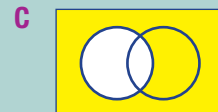
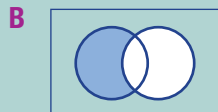
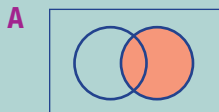

- 3 In a class of 28, each student owns a cat or a dog or both. If 18 students own cats and 16 students own dogs, how many students own both a cat and a dog?
- 4 Write down the set of five positive integers that has a mean of 5, a mode of 8 and a range of 6.
- 5 A 6-sided die and a 10-sided die are tossed simultaneously. What total sums have the highest chance of occurring? (A total sum means the sum of the two uppermost faces.)
- 6 Michael needs to deliver parcels to three places (A, B and C, in order) in the city. This diagram shows the different ways that he can travel.

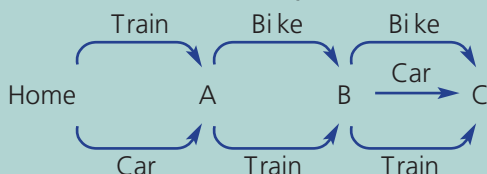

- a Draw a tree diagram showing all the possible combinations of transportation.
- b What is the total number of possible outcomes?
- c Find the probability that Michael will use a different transport each time.

Statistics and probability

Two-step experiments
 These can be represented by tables or tree diagrams. They involve more than one step and can occur with or without replacement.
 E.g. a bag contains 2 blue counters and 1 green, 2 are selected at random.
 (I) Table with replacement.

	Pick 1			
	b	b	g	
Pick 2	b	bb	bb	gb
	b	bb	bb	gb
	g	bg	bg	gg

Sample space of 9 outcomes
 $\Pr(2 \text{ of same colour}) = \frac{5}{9}$

(II) Tree without replacement

```

    Pick 1   Pick 2
    /  \   /  \
   b    g b    g
  /  \  /  \
 b    g b    g
/  \  /  \
b    g b    g

```

6 outcomes
 $\Pr(2 \text{ of same colour}) = \frac{2}{6} = \frac{1}{3}$

Venn diagrams and two-way tables
 These organise data from two or more categories

Venn diagram

	A	Not A	Totals
B	7	3	10
Not B	5	6	11
Totals	12	9	21

i.e. 6 in neither category, 7 in both categories
 $\Pr(A) = \frac{12}{21} = \frac{4}{7}$
 $\Pr(B \text{ only}) = \frac{3}{21} = \frac{1}{7}$

Probability review
 The sample space is the list of all possible outcomes of an experiment.
 For all possible outcomes:
 $\Pr(\text{event}) = \frac{\text{number of outcomes where event occurs}}{\text{total number of outcomes}}$
 E.g. roll a normal six-sided die
 $\Pr(>4) = \frac{2}{6} = \frac{1}{3}$
 $0 \leq \Pr(\text{event}) \leq 1$
 $\Pr(\text{not } A) = 1 - \Pr(A)$

Stem-and-leaf plots
 These display all the data values using a stem and a leaf.
 An ordered back-to-back stem-and-leaf plot.

	Leaf	Stem	Leaf	
skewed	9 8 7 2	1	0 3	symmetrical
	7 4 3 3	2	2 2 4	
	5 2 1	3	3 6 7 8	
	7	4	4 5 9	
	0	5	0	
	3 5			

means 35
 key

Experimental probability
 This is calculated from results of an experiment or survey.
 $\text{Experimental probability} = \frac{\text{number of times event occurs}}{\text{total number of trials}}$
 Expected number = probability \times number of occurrences

Measure of spread
 Range = maximum value – minimum value

Summarising data: Measures of centre
 Mode is the most common value (there can be more than one). Two modes means data is bimodal.
 $\text{Mean} = \frac{\text{sum of all values}}{\text{number of values}}$
 Median is the middle value of data that is ordered.

odd data set	even data set
2 4 <u>7</u> 10 12	2 4 6 <u>10</u> 15 18
median	median

$\text{median} = \frac{6+10}{2}$

An outlier is a value that is not near the rest of the data.

Grouped data
 Data values can be grouped into class intervals, e.g. 0–4, 5–9 etc. and recorded in a frequency table.
 The frequency or percentage frequency of each interval can be recorded in a histogram.

Frequency table

Class interval	Frequency	Percentage frequency
0–	10	20
5–	20	40
10–	5	10
15–20	15	30
Total	50	100

Frequency histogram

Chapter checklist

A version of this checklist that you can print out and complete can be downloaded from your Interactive Textbook.

10A	<p>1 I can calculate a probability from experiments with equally likely outcomes. e.g. A letter is chosen from the word COMPLEMENT. Find the probability that the letter is:</p> <p>a an E b not a vowel c an E or a consonant</p>	✓
10B	<p>2 I can use a Venn diagram to calculate probabilities. e.g. From a group of 30 tennis players, 16 do a slice backhand, 18 do a top-spin backhand and 6 do both types of backhand. Illustrate this information in a Venn diagram and</p> <p>a state the number of tennis players who do a slice backhand only b find the probability that a randomly selected tennis player does a slice or a top-spin backhand.</p>	
10B	<p>3 I can use a two-way table to calculate probabilities. e.g. From a group of 20 single car owners, 15 have a car which runs on petrol, 7 have a car which runs on electricity and 4 people have a car which runs on both types of fuel. Illustrate this information using a two-way table and</p> <p>a find the number of people who have a car that runs on neither type of fuel b find the probability that a randomly selected car owner has a car which runs on petrol only.</p>	
10C	<p>4 I can construct an array (table) for a two-step experiment with replacement. e.g. A fair 4-sided die is rolled twice. List all the outcomes (the sum total from the two dice) using a table and find:</p> <p>a Pr(a double) b Pr(sum of at least 5) c Pr(sum not equal to 7).</p>	
10C	<p>5 I can construct an array (table) for a two-step experiment without replacement. e.g. Two letters are chosen from the word KEY, without replacement. Construct a table to list the sample space and find the probability of:</p> <p>a obtaining the outcome (K, E) b selecting an E or a Y in any order.</p>	
10D	<p>6 I can construct and use a tree diagram to find probabilities for multistage experiments with replacement. e.g. Two marbles are selected from a container including 2 clear and 2 coloured marbles. Two marbles are randomly chosen with replacement. Represent the selections using a tree diagram that shows all possible outcomes. Find the probability of selecting:</p> <p>a one clear marble b at least one coloured marble.</p>	
10D	<p>7 I can construct and use a tree diagram to find probabilities for multistage experiments without replacement. e.g. A box contains 2 dark and 3 white chocolates. Draw a tree diagram to show the outcomes and probabilities of the selection of two chocolates without replacement. Find the probability of selecting:</p> <p>a one white b at least one dark chocolate.</p>	
10E	<p>8 I can find an experimental probability and expected number of occurrences. e.g. 40 people were surveyed regarding their main mode of transport to work. 25 said <i>Public transport</i>, 10 said <i>Drive</i> and 5 said <i>Walk</i>. Find:</p> <p>a the experimental probability that a person drives to work b the expected number of people who use public transport from a group of 1000.</p>	
10F	<p>9 I can find the mean, median, mode and range of a simple data set. e.g. For the data sets: 3, 4, 5, 2, 3, 3, 1 and 12, 21, 21, 25, 18, 14 find:</p> <p>a the mean b median c mode d range</p>	





10F

10 I can solve problems associated with data means.

e.g. Hilbert received 78, 59, 66 and 69 on his previous four maths tests. What is his current average and what does he need to score in his next test to raise his average to 70?

10G

11 I can interpret a common statistical graph.

e.g. This column graph shows how many goals four teams scored in a round of soccer.

- a** How many goals did the Blues score?
b What was the mean and median score for the four teams?
c What combined percentage of the goals were scored by the Reds and the Blues?

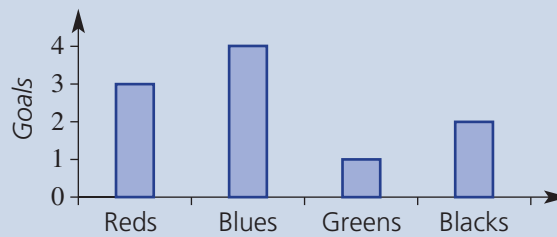

10G

12 I can decide if a graph may be misleading.

e.g. The following two graphs shows the two-party preferred position of the Labor and Liberal parties after an election. Which one provides a misleading margin of difference and why?

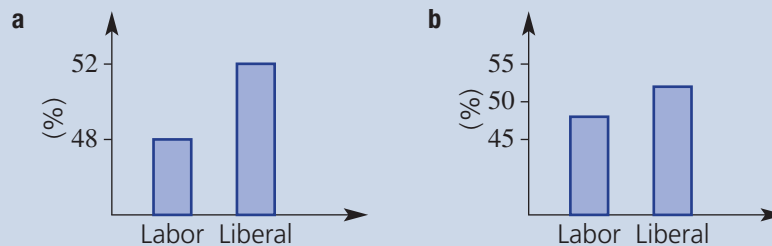

10H

13 I can construct a stem-and-leaf plot from a data set and calculate summary statistics.

e.g. For this data set construct a stem-and-leaf plot and find the mode and median.
 26 19 32 42 49 16 35 29 22 25 26 37 15 28

10H

14 I can construct a back-to-back stem-and-leaf plot and compare the two data sets.

e.g. The total games scores of two tennis teams for a season of 9 matches is recorded as follows.

Team A

31 45 69 40 76 55 49 12 28

Team B

23 34 16 29 27 12 25 29 31

Construct an ordered back-to-back stem-and-leaf plot and compare and comment on the differences between the performance of the two teams.

10I

15 I can construct and analyse a frequency table and a histogram.

e.g. The age of 20 tagged sea turtles is recorded as follows.

45 63 79 66 38 97 82 44 59 31

58 62 69 53 85 93 85 77 62 41

Organise the data into a frequency table, using class intervals of 10, and include a percentage frequency column. Construct a frequency histogram and a percentage frequency histogram and determine the percentage of turtles older than 50 years.

Short-answer questions

- 10A 1** Determine the probability of each of the following.
- Rolling more than 2 on a normal six-sided die
 - Selecting a vowel from the word EDUCATION
 - Selecting a pink or white jelly bean from a packet containing 4 pink, 2 white and 4 black jelly beans

- 10B 2** From a survey of 50 people, 30 have the newspaper delivered, 25 read it online, 10 do both and 5 do neither.

- Construct a Venn diagram for the survey results.
- How many people only read the newspaper online?
- If one of the 50 people were randomly selected, find:
 - Pr(have paper delivered and read it online)
 - Pr(don't have it delivered)
 - Pr(only read it online)



- 10B 3 a** Copy and complete this two-way table.

	A	Not A	Total
B		16	
Not B	8		20
Total	17		

- b** Convert the information into a Venn diagram, as shown.



- c** Find the following.
- Pr(not B)
 - Pr(both A and B)
 - number of 'A only'
 - number in either A or B or both A and B

- 10C 4** A spinner with equal areas of red, green and blue is spun and a four-sided die numbered 1 to 4 is rolled.

- Complete a table like the one shown and state the number of outcomes in the sample space.
- Find the probability that:
 - the outcome is red and an even number
 - the outcome is a blue 4 or a green 4
 - the outcome does not involve blue

		Die			
		1	2	3	4
Spinner	red	(red, 1)	(red, 2)		
	green				
	blue				

- 10D 5** Libby randomly selects two coins from her pocket *without replacement*. Her pocket contains a \$1 coin and two 10-cent coins.
- List all the possible combinations using a tree diagram.
 - If a chocolate bar costs \$1.10, find the probability that she can hand over the two coins to pay for it.

- 10E 6** A quality controller records the frequency of the types of chocolates from a sample of 120 off its production line.

Centre	Soft	Hard	Nut
Frequency	50	22	48

- a** What is the experimental probability of randomly selecting a nut centre?
b In a box of 24 chocolates, how many would be expected to have a non-soft centre?

- 10F 7** Claudia records the number of emails she receives each weekday for two weeks as follows.



30 31 33 23 29 31 21 15 24 23

Find:

- a** the mean
b the median
c the mode
d the range

- 10H 8** Two mobile phone salespeople are both aiming for a promotion to be the new assistant store manager. The best salesperson over a 15-week period will achieve the promotion. The number of mobile phones they sold each week is recorded below.



Employee 1: 21 34 40 38 46 36 23 51 35 25 39 19 35 53 45

Employee 2: 37 32 29 41 24 17 28 20 37 48 42 38 17 40 45

- a** Draw an ordered back-to-back stem-and-leaf plot for the data.
b For each employee, find:
i the median number of sales
ii the mean number of sales
c By comparing the two sets of data, state, with reasons, who you think should get the promotion.
d Describe each employee's data as approximately symmetrical or skewed.

- 10I 9** The data below represents the finish times, in minutes, of 25 competitors in a local car rally race.

134 147 162 164 145 159 151 143 136 155 163 157 168

171 152 128 144 161 158 136 178 152 167 154 161

- a** Record the above data in a frequency table in class intervals of 120–, 130– etc. Include a percentage frequency column.
b Construct a frequency histogram.
c Determine:
i the number of competitors that finished in less than 140 minutes
ii the percentage of competitors that finished between 130 and 160 minutes

- 10G 10** This column graph shows the value of some of the boats that were badly damaged in cyclone Yasi in North Queensland in 2011.



- a** Find the mean and median boat value.
b Do you think the mean or the median would better represent the 'average' of these boat values? Give a reason for your answer.

Value of boats damaged in cyclone

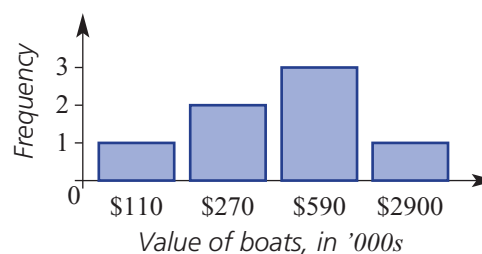

Multiple-choice questions

10A 1 A letter is randomly chosen from the word XYLOPHONE. The probability that it is an O is:

- A** $\frac{1}{8}$ **B** $\frac{2}{9}$ **C** $\frac{1}{4}$ **D** $\frac{1}{9}$ **E** $\frac{1}{3}$

10B 2 The values of x and y in the two-way table are:

- A** $x = 12, y = 8$ **B** $x = 12, y = 11$
C $x = 16, y = 4$ **D** $x = 10, y = 1$
E $x = 14, y = 6$

	A	Not A	Total
B		5	9
Not B	8	y	
Total	x		25

10B 3

- Which shaded region represents both A and B?
- Which shaded region represents A only?
- Which shaded region represents A or B or both?
- Which shaded region represents the complement of B and not A?

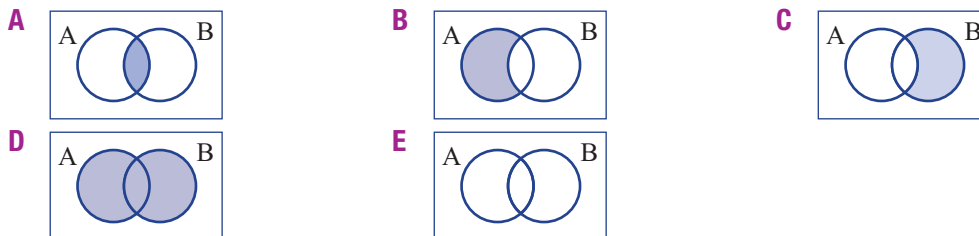

10D 4 A bag contains 2 green balls and 1 red ball. Two balls are randomly selected *without replacement*. Using a tree diagram, the probability of selecting one of each colour is:

- A** $\frac{1}{2}$ **B** $\frac{2}{3}$ **C** $\frac{5}{6}$ **D** $\frac{1}{3}$ **E** $\frac{3}{4}$

10E 5 From rolling a biased die, a class finds an experimental probability of 0.3 of rolling a 5. From 500 rolls of the die, the expected number of 5s would be:

- A** 300 **B** 167 **C** 180 **D** 150 **E** 210

10H 6 i The median of the data in this stem-and-leaf plot is:

- A** 74 **B** 71 **C** 86
D 65 **E** 70

ii The range of the data in the stem-and-leaf plot is:

- A** 3 **B** 8 **C** 33
D 86 **E** 14

Stem	Leaf
5	3 5 8
6	1 4 7
7	0 2 4 7 9
8	2 6 6
7 4	means 74

10F 7 If Jacob achieved scores of 12, 9, 7 and 12 on his last four language vocabulary tests, what score must he get on the fifth test to have a mean of 11?

- A** 16 **B** 14 **C** 11 **D** 13 **E** 15

10I 8 This frequency histogram shows the times of finishers in a fun run. The percentage of competitors that finished in better than 40 minutes was:

- A** 55% **B** 85% **C** 50%
D 62.5% **E** 60%

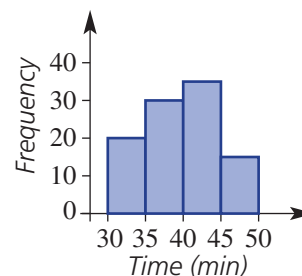

Extended-response questions

- 1 The local Sunday market has a number of fundraising activities.
- a For \$1 you can spin a spinner numbered 1–5 twice. If you spin two even numbers you receive \$2 (your dollar back plus an extra dollar), if you spin two odd numbers you receive your dollar back and for any other result you lose your dollar.
- i Complete the table shown to list the sample space.

		First spin				
		1	2	3	4	5
Second spin	1	(1, 1)	(2, 1)			
	2					
	3					
	4					
	5					

- ii What is the probability of losing your dollar (i.e. spinning one odd and one even number)?
- iii What is the probability of making a dollar profit (i.e. spinning two even numbers)?
- iv In 50 attempts, how many times would you expect to lose your dollar?
- v If you start with \$100 and have 100 attempts, how much money would you expect to end up with?
- b Forty-five people were surveyed as they walked through the market as to whether they bought a sausage and/or a drink from the sausage sizzle. Twenty-five people bought a sausage and 30 people bought a drink, with 15 buying both.
- i Construct a Venn diagram to represent this information.
- ii How many people bought neither a drink nor a sausage?
- iii How many people bought a sausage only?
- iv If a person was randomly selected from the 45, what is the probability they bought a drink but not a sausage?
- v Find \Pr (didn't buy a sausage).



- 2 The delay time (in minutes) of the flight departure of the same evening flight of two rival airlines was recorded over 30 consecutive days. The data is shown below.

Airline A 2 11 6 14 18 1 7 4 12 14 9 2 13 4 19
13 17 3 52 24 19 12 14 0 7 13 18 1 23 8

Airline B 6 12 9 22 2 15 10 5 10 19 5 12 7 11 18
21 15 10 4 10 7 18 1 18 8 25 4 22 19 26

- a Copy and complete this ordered back-to-back stem-and-leaf plot for the data. Use 2 lines for each stem, starting with '0' for leaves 0 – 4, and then '0*' for leaves 5 – 9 etc.
- b Does the data for airline A appear to have any outliers (numbers not near the majority of data elements)?
- c By removing any outliers listed in part b, find the following for each airline, rounding to one decimal place where necessary.
- i the median
- ii the mean
- d Airline A reports that half its flights for that month had a delay time of less than 10 minutes. Is this claim correct? Explain.

Airline A		Airline B
	0	
	0*	
	1	
	1*	
	2	
	2*	
	3	
	3*	
	4	
	4*	
	5	
	1 2 means 12	
	1* 5 means 15	

Measurement

Short-answer questions



1 Find the area of these basic shapes.

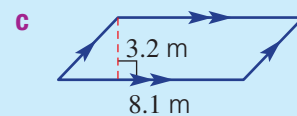
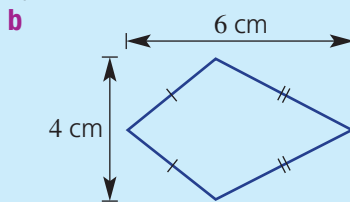
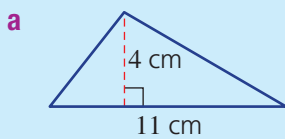

2 Find the circumference and area of these circles, correct to two decimal places.

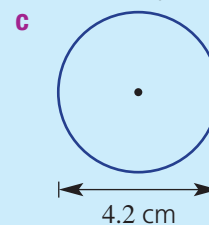
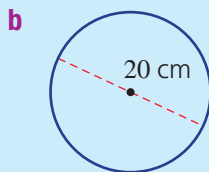
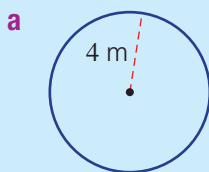

3 Find the area of each of the figures below. Round to two decimal places where necessary.

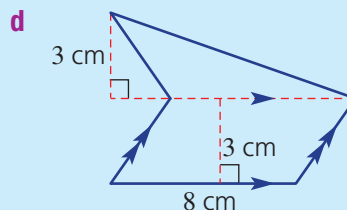
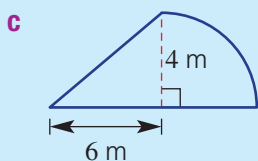
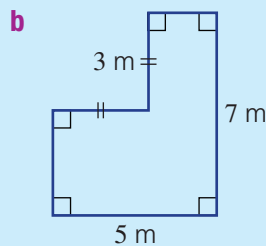
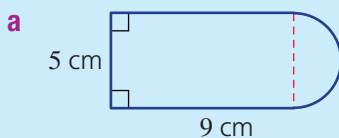

4 Find the total surface area of these solid objects. Round to two decimal places where necessary.

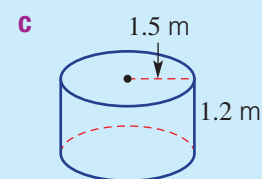
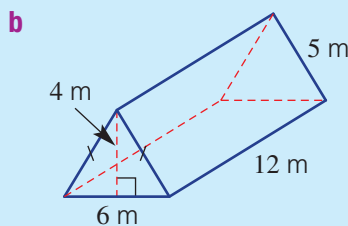
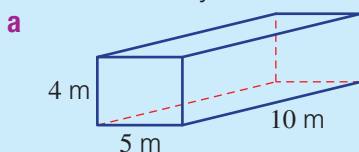

5 Find the volume of these solids. Round to two decimal places for part **c**.

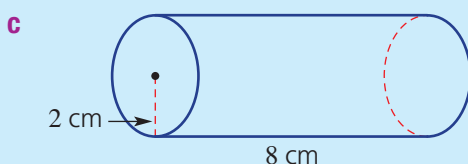
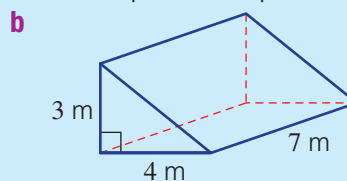
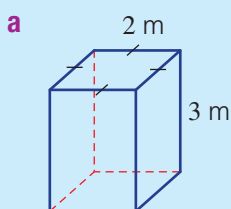

Multiple-choice questions

1 The perimeter and area of this triangle, respectively, are:

- A** 48 cm, 24 m² **B** 68 cm, 80 cm²
C 24 cm, 24 cm² **D** 24 cm, 12 cm³
E 24 cm, 48 cm²

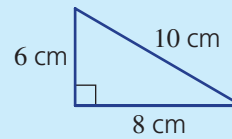

2 The circumference and area for this circle, correct to two decimal places, respectively, are:

- A** 37.70 m, 18.85 m² **B** 9.42 m, 56.55 m²
C 18.85 m, 28.27 m² **D** 18.85 m, 18.85 m²
E 9.42 m, 28.27 m²

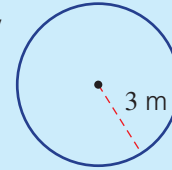

3 420 cm² is equal to:

- A** 4.2 m² **B** 0.42 m² **C** 42 000 m² **D** 0.042 m² **E** 0.0042 m²



4 The perimeter and area of the figure shown, respectively, are:

- A** 20.2 m, 22.42 m² **B** 24.8 m, 22.42 m²
C 24.8 m, 25.15 m² **D** 20.2 m, 25.15 m²
E 21.6 m, 24.63 m²

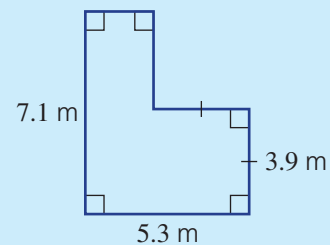

5 The volume of the cylinder shown is closest to:

- A** 703.7 cm³ **B** 351.9 cm³
C 2814.9 cm³ **D** 452.4 cm³
E 1105.8 cm³

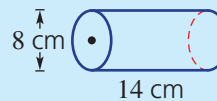

Extended-response question

A pond is to be built inside a rectangular garden, as shown.



- a** Find the area of the pond, correct to two decimal places.
b What is the area of the garden, not including the pond?
c The pond is to be surrounded by a low wall that costs \$50 per metre. What will it cost to build this wall? Round to the nearest dollar.

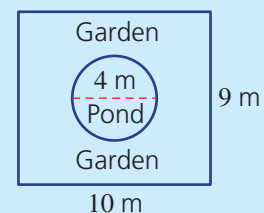

Indices

Short-answer questions

1 Use index laws to simplify the following.

a $5p^2q \times 3pq$ **b** $\frac{9a^6b^3}{18a^4b^2}$ **c** $(-3x^4y^2)^2 \times 6xy^2$ **d** $-3x^0 + (5x)^0$

 2 Write each of the following using positive indices and then write as a basic numeral.

a $\frac{3}{4^{-2}}$ **b** 4×10^{-3}

3 Write these numbers as basic numerals.

a 2.4×10^3 **b** 1.08×10^6 **c** 7.1×10^{-3} **d** 2.06×10^{-5}

4 Write these numbers using scientific notation.

a 60 300 **b** 2 700 000 **c** 0.004 **d** 0.000703

 5 Convert these numbers to the units given in brackets. Write your answer using scientific notation using three significant figures.

a 30.71 g (kg) **b** 4236 tonnes (kg)
c 3.4 hours (seconds) **d** 235 seconds (years)

Multiple-choice questions

1 $3a^2b^3 \times 4ab^2$ is equivalent to:

A $12a^2b^6$ **B** $7a^3b^5$ **C** $12a^3b^5$ **D** $12a^4b^5$ **E** $7a^2b^6$

2 $\left(\frac{2x}{5}\right)^3$ is equivalent to:

A $\frac{6x^3}{5}$ **B** $\frac{8x^3}{125}$ **C** $\frac{2x^3}{5}$ **D** $\frac{2x^4}{15}$ **E** $\frac{2x^3}{125}$

 3 4^{-2} can be expressed as:

A $\frac{1}{4^{-2}}$ **B** $\frac{1}{8}$ **C** -16 **D** $\frac{1}{16}$ **E** -8

4 3×10^{-4} written with positive indices is:

A -3×10^4 **B** $\frac{1}{3 \times 10^4}$ **C** $\frac{-3}{10^4}$ **D** $\frac{1}{3 \times 10^{-4}}$ **E** $\frac{3}{10^4}$

5 0.00371 in scientific notation is:

A 0.371×10^{-3} **B** 3.7×10^{-2} **C** 3.71×10^{-3} **D** 3.71×10^3 **E** 371×10^3

Extended-response question

The average human body contains about 74 billion cells. (Note: 1 billion = 1 thousand million)

a Write this number of cells:

- i** as a basic numeral
- ii** using scientific notation

-  **b** If the population of a particular city is 2.521×10^6 , how many human cells are there in the city? Give your answer using scientific notation correct to three significant figures.
- c** If the average human weighs 64.5 kilograms, what is the average mass of one cell in grams? Give your answer using scientific notation correct to three significant figures.

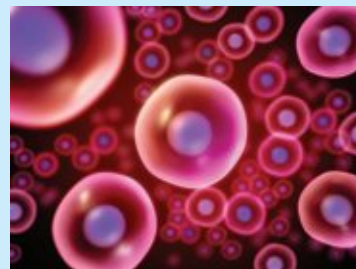

Geometry

Short-answer questions

★ 1 State the angle sums for these shapes.

- A Triangle
- B Quadrilateral
- C Pentagon
- D Heptagon
- E Octagon
- F Decagon

2 Find the value of each pronumeral in the following.

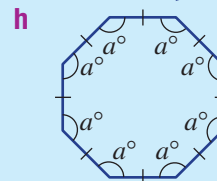
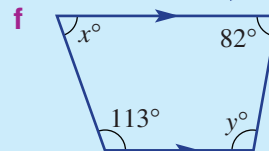
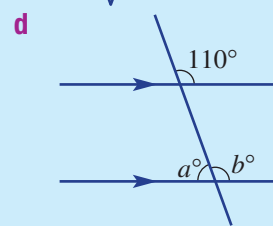
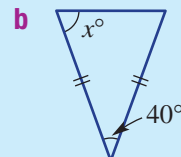
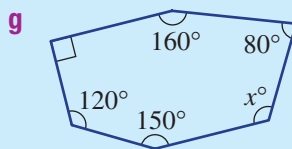
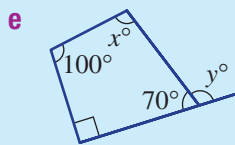
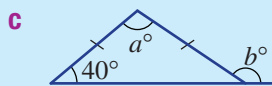
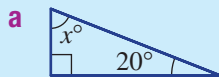

3 The two given triangles are similar.

- a Are they congruent? Give a reason.
- b Write a congruence statement.
- c Which side on $\triangle ABC$ corresponds to side DE on $\triangle DEF$?

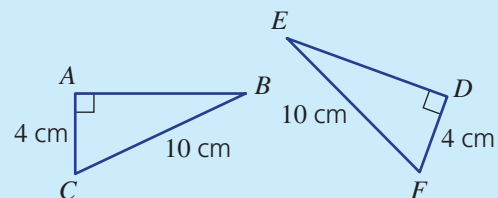

4 For the given pair of triangles (not to scale):

- a give a reason (SSS, SAS, AAA or RHS) why they are similar
- b find the scale factor

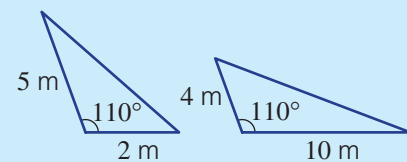

5 For this pair of triangles:

- a give a reason why the two triangles are similar
- b find the value of x

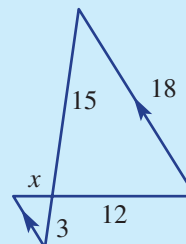

Multiple-choice questions

- 1 The supplementary angle to 55° is:
A 55° **B** 35° **C** 125° **D** 135° **E** 70°
- 2 A quadrilateral with all four sides equal and opposite sides parallel is best described by a:
A parallelogram **B** rhombus **C** rectangle
D trapezium **E** kite
- 3 The size of the interior angle in a regular pentagon with angle sum 540° is:
A 108° **B** 120° **C** 96° **D** 28° **E** 115°
- 4 The test that proves congruence in these two triangles is:
A SAS **B** RHS **C** AAA
D SSS **E** AAS

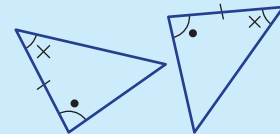

- 5 What is the scale factor that enlarges shape 1 to shape 2 in these similar figures, and what is the value of x ?
A 2 and $x = 8$ **B** 2.5 and $x = 7.5$
C 3.33 and $x = 13.33$ **D** 2.5 and $x = 12.5$
E 2 and $x = 6$

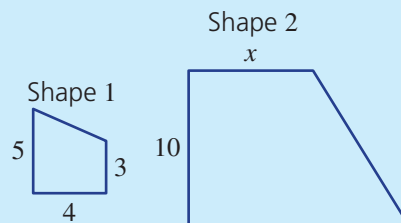

Extended-response question



A vertical wall is being supported by a piece of timber that touches the ground 10 metres from the base of the wall. A vertical metal support 4.5 m high is placed under the timber support 4 m from the wall.

- a** Give a reason why $\triangle ABD \parallel \triangle ECD$.
b What is the length DC ?
c What is the scale factor for the two triangles formed by the timber and support?
d Find how far the timber reaches up the wall.
e How far above the ground is the point halfway along the timber support?

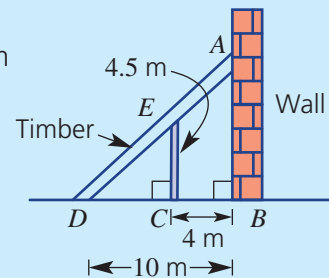

Algebraic techniques

Short-answer questions

- 1 Expand these expressions.
- | | | |
|-------------------------|-------------------------|-----------------------|
| a $-3(x+2)$ | b $x(1-x)$ | c $(x+1)(x-1)$ |
| d $(x-4)^2$ | e $(5x-2)(5x+2)$ | f $(3x-4)^2$ |
| g $(4x-1)(2x+3)$ | h $5x-3(x-1)$ | i $(2-x)^2$ |
- 2 Simplify these expressions.
- | | | |
|-------------------------------|-----------------------------|-----------------------------|
| a $-3x \times 2yx$ | b $7a \times 6ab^2$ | c $4ab \div (8b)$ |
| d $-6x^2y \div (xy^2)$ | e $a^2b \div (ab^2)$ | f $2xy \div (4xy^2)$ |

3 Find the area of the following shapes in expanded form.

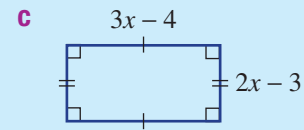
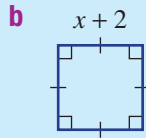
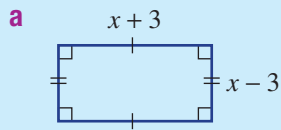

4 Factorise the following.

a $3x - 12$

b $-7x - 14$

c $5x^2 + 2x$

d $14x^2 - 21x$

5 Simplify these expressions.

a $\frac{5x^2}{3} \times \frac{9}{10x}$

b $\frac{x-1}{2} \times \frac{3}{2(x-1)}$

c $\frac{4x-8}{x-2}$

d $\frac{-6x^2 - x}{6x+1}$

e $\frac{4x}{3} \div \frac{8x}{9}$

f $\frac{3(x-2)}{5a} \div \frac{x(x-2)}{15a^2}$



6 Simplify these algebraic fractions.

a $\frac{x}{3} - \frac{x}{4}$

b $\frac{5x}{4} + \frac{7x}{5}$

c $\frac{x+1}{2} + \frac{x}{5}$

d $\frac{2x-1}{5} + \frac{x+2}{3}$

Multiple-choice questions

1 $-3(x-4)$ is equal to:

A $-3x+7$

B $-3x+4$

C $-3x-4$

D $-3x-12$

E $-3x+12$

2 The expanded form of $(x+4)(3x-2)$ is:

A $3x^2+12x-8$

B $4x^2+14x-8$

C $3x^2+12x-10$

D $3x^2-8$

E $3x^2+10x-8$

3 $(2x-1)^2$ expands to:

A $4x^2-4x+1$

B $2x^2-2x-1$

C $2x^2-4x+1$

D $4x^2-2x+1$

E $4x^2-1$



4 $\frac{2x-6}{2}$ simplifies to:

A $2x-3$

B $x-3$

C $2x-4$

D $x-6$

E $x-4$



5 $\frac{x+1}{3} + \frac{x}{4}$ simplifies to:

A $\frac{7x+1}{12}$

B $\frac{7x+4}{7}$

C $\frac{5x+4}{7}$

D $\frac{7x+4}{12}$

E $\frac{5x-3}{8}$

Extended-response question

A room that is 10 metres long and 8 metres wide has a rectangular rug in the middle of it that leaves a border, x metres wide, all the way around it as shown.

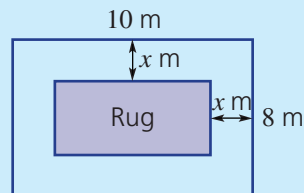

- Write expressions for the length and the width of the rug.
- Write an expression for the area of the rug in expanded form.
- What is the area of the rug when $x = 1$?

Statistics and probability

Short-answer questions

- 1** In a survey of 30 people, 18 people drink coffee during the day, 14 people drink tea and 8 people drink both. Let C be the set of people who drink coffee and T the set of people who drink tea.
- Construct a Venn diagram for the survey results.
 - Find:
 - the number who drink either coffee or tea or both
 - the number who do not drink tea
 - If one of the 30 people was randomly selected, find:
 - $\Pr(\text{drinks neither coffee nor tea})$
 - $\Pr(C \text{ only})$
- 2** A coin and a four-sided die are tossed.
- Draw a table to show the sample space.
 - How many outcomes are in the sample space?
 - What is the probability of tossing T4?
 - What is the probability of tossing tails and an odd number?
- 3** A spinner has equal areas for the colours blue, orange and yellow. It is spun twice.
- Draw a tree diagram and list the outcomes.
 - Find the probability of orange then blue.
 - Find the probability that both outcomes are the same colour.
 - Find the probability that blue and yellow show in any order.
- 4** Two ice creams are randomly selected without replacement from a box containing one vanilla (V), two strawberry (S) and one chocolate (C) flavoured ice creams.
- Draw a tree diagram to show each of the possible outcomes.
 - What is the probability of selecting:
 - a vanilla and a strawberry flavoured ice cream?
 - two strawberry flavoured ice creams?
 - no vanilla-flavoured ice creams?
- 5** The data below shows the number of aces served by a player in each of their grand slam tennis matches for the year.

15 22 11 17 25 25 12 31 26 18 32 11 25 32 13 10

- Construct a stem-and-leaf plot for the data.
- From the stem-and-leaf plot, find the mode and median number of aces.
- Is the data symmetrical or skewed?



- 6** The frequency table shows the number of visitors, in intervals of 50, to a theme park each day in April.
- Complete the frequency table shown. Round to one decimal place where necessary.
 - Construct a frequency histogram.
 - On how many days were there fewer than 100 visitors?
 - What percentage of days had between 50 and 199 visitors?

Class interval	Frequency	Percentage frequency
0–	2	
50–	4	
100–	5	
150–	9	
200–		
250–	3	
Total	30	

Multiple-choice questions

1 The probability of rolling a number less than five on a normal six-sided die is:

- A $\frac{1}{3}$ B 4 C $\frac{1}{2}$ D $\frac{2}{3}$ E 3

2 From the two-way table, Pr(both A and B) is:

- A $\frac{1}{5}$ B 4 C $\frac{9}{20}$ D $\frac{1}{4}$ E 16

	A	Not A	Total
B		7	
Not B	5		
Total		11	20

3 In a bag of 40 marbles, 28 are blue.

a The probability of selecting a blue marble is:

- A 0.28 B 0.4 C 0.7 D 0.54 E 0.75

b If a marble is selected 50 times *with replacement*, the number of blue marbles you would expect to select is:

- A 28 B 38 C 70 D 35 E 40

4 The median, mean and range of the data set
12 3 1 6 10 1 5 18 11 15
are respectively:

- A 5.5, 8.2, 1 – 18 B 8, 8.2, 17 C 5.5, 8, 17 D 8, 8.2, 1 – 18 E 8, 74.5, 18

5 The median of this stem-and-leaf plot is:

- A 55 B 67 C 7 D 69 E 4

Stem	Leaf
5	1 3 5 5 5 5
6	2 4 5 6 7 7 9
7	1 3 4 8 9
8	3 4
9	1 2 6

5 | 1 means 51

Extended-response question

A game at the school fair involves randomly selecting a green ball and a red ball, each numbered 1, 2 or 3.

- a List the outcomes in a table.
b What is the probability of getting an odd and an even number?
c Participants win \$1 when they draw each ball showing the same number.

- i What is the probability of winning \$1?
ii If someone wins six times, how many games are they likely to have played?



- d The ages of those playing the game in the first hour are recorded and are shown below.
12 16 7 24 28 9 11 17 18 18 37 9 40 16 32 42 14
i Approximately 50% of the participants are below what age?
ii If this data is used as a model for the 120 participants throughout the day, how many would be expected to be aged less than 30?



A

Acute angle Between 0 and 90 degrees

Adjacent (side) In a right-angled triangle, the side adjacent to (next to) the unknown angle

Algebraic fraction A fraction including pronumerals

Algorithm A sequence of steps that, when followed, lead to the solution of a problem

Alternate angles A pair of angles lying on opposite sides of a transversal but inside two other lines

Angle The difference in direction between two lines

Angle of depression The angle of your line of sight from the horizontal when looking down at an object

Angle of elevation The angle of your line of sight from the horizontal when looking up at an object

Angle sum The total measure of the angles in a plane figure

Area A measure of surface in square units

Array A rectangular table for listing outcomes

Average The central value of a data set

Axis of symmetry A vertical line that divides a parabola into two symmetrical halves

B

Back-to-back stem-and-leaf plot A visual representation of two sets of data that groups the scores and lists them in order horizontally on either side of the stem

Base A number or pronumeral that is being raised to a power

Bimodal A data set with two modes

Binomial product The product of two binomial expressions

C

Capacity The amount of liquid a container can hold

Cartesian plane A plane on which every point is related to a pair of numbers called coordinates

Chance The probability of an event occurring

Circle A simple round shape with a centre and radius

Circumference The curved boundary of a circle

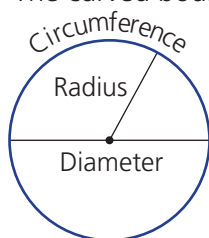

Class interval A numerical interval for grouped data

Coefficient A numeral multiplied by a pronumeral

Cointerior angles A pair of angles lying between two lines on the same side of a transversal

Column graph A graph that uses columns to compare data in categories

Commission The proportion of a sales amount earned by an employee

Common factor A number/expression which divides into two or more expressions

Complement A set of outcomes containing the elements that are not in another given set

Complementary angles Angles that sum to 90 degrees

Composite shape A complex shape made up of two or more basic shapes

Congruence statement A statement linking the vertices of congruent figures

Congruent figures Figures that are exactly the same size and shape

Constant term The part of an equation or expression without any pronumerals

Convex (polygon) A polygon with all interior angles less than 180 degrees

Coordinate pair (coordinates) An ordered pair written in the form (x, y) that states the location of a point on the Cartesian plane

Corresponding angles A pair of angles sitting in similar positions after a transversal cuts two or more lines

Corresponding sides Sides that are in the same position in two or more shapes

Cosine The ratio of the length of the adjacent side to the length of the hypotenuse

Cost price The price at which goods have been bought by a retailer

Critical digit The digit that determines whether you round the previous digit up or down

Cross-section The plane figure formed when you slice a solid figure parallel to one of its surfaces

Cube (number) The product of a number multiplied by itself twice

Cylinder A solid with a uniform circular cross-section

D

Decimal A number expressed using a system of counting based on the number ten: Three-fifths as a decimal is 0.6

Decimal places The number of digits to the right of the decimal point

Deductions Amounts of money taken from gross income

Denominator Parts in the whole. The part of a fraction that sits below the dividing line.

Dependent variable The value that changes in response to changes made in the independent variable

Diagonal A line segment across a shape joining two vertices

Diameter A line passing through the centre of a circle with its end points on the circumference

Difference of perfect squares When one square term is subtracted from another

Direct proportion The relationship between two quantities that increase or decrease at the same rate

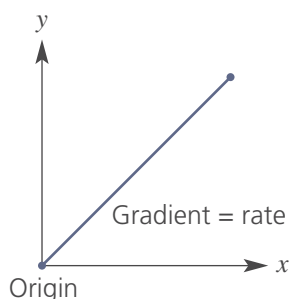

Discount An amount subtracted from a price

Distributive law Adding numbers in brackets, *then* multiplying the total, gives the same answer as multiplying each number in the brackets separately first, *then* adding the products

Dot plot A statistical graph which uses dots piled vertically to illustrate frequency

Double time A pay rate of overtime that is 2 times the normal hourly rate

E

Endpoints The coordinates of the points at the end of an interval

Enlargement A transformation that changes the size of a figure without changing its shape

Equation A statement that two expressions have the same value

Equilateral triangle A triangle with three equal sides and all angles 60 degrees

Equivalent equations Two equations that produce the same solution

Equivalent fractions Fractions with the same value

Evaluate To work out the numerical value

Event Outcomes resulting from an experiment

Expand Remove grouping symbols (such as brackets)

Expanded form An expression without brackets

Expected number of occurrences The expected number of favourable outcomes from an experiment

Experiment A situation involving chance or probability trials

Experimental probability Probability based on measuring the outcomes of trials

Exponent A number that shows how many times another number (the base) is to be multiplied by itself. Also called the Index or power.

Expression A collection of mathematical terms containing no equals sign

Exterior angle The angle formed between the extended side and the adjacent side of a polygon

F

Factor A number or expression that divides in without a remainder

Factorise To write an expression as a product

Favourable outcome An outcome that is desired from an experiment

Formula A rule for finding the value of one quantity given the values of others

Fraction A number that results from dividing one whole number by another

Frequency table A table summarising data by showing all possible scores from lowest to highest in one column, and the frequency of each score in another column

G

Gradient The steepness of a straight line or interval

Gradient–intercept form The equation of a straight line, written with y as the subject of the equation

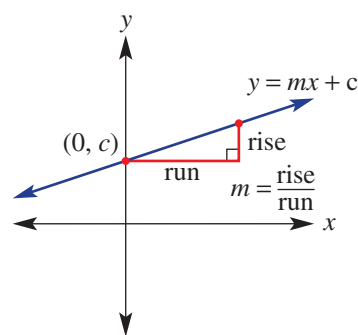

Gross income Total income before any deductions are made

H

Highest common factor (HCF) The largest number/expression which divides into two or more expressions

Histogram A special type of column graph with no gaps between the columns

Horizontal Parallel to the ground, at right angles to the vertical

Hypotenuse The longest side of a right-angled triangle

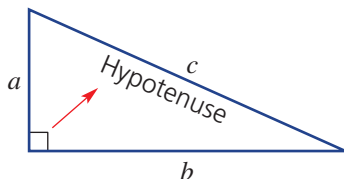

I

Image The resulting figure after a transformation

Improper fraction A fraction where the numerator is larger than or equal to the denominator

Income tax An amount paid to the government by people earning an income

Independent variable The value that is deliberately controlled when collecting data

Index The number of times a factor is repeated under multiplication

Index form A method of writing numbers that are multiplied by themselves

Index law A mathematical law which is true for expressions involving indices

Integer A number in the infinite set $\{\dots, -3, -2, -1, 0, 1, 2, 3, \dots\}$

Inverse Opposite in relation to something. The inverse of addition is subtraction.

Inverse cosine The angle of which the cosine ratio is given

Inverse sine The angle of which the sine ratio is given

Inverse tangent The angle of which the tangent ratio is given

Irrational number A real number that cannot be expressed as a fraction

Isosceles triangle A triangle with a pair of equal sides and a pair of equal angles

K

Kite A quadrilateral with two pairs of adjacent equal sides

L

Length A measure of distance

Like terms Terms with the exact same pronumerals including powers

Line A continuous set of points without breadth or thickness

Line segment A section of a straight line

Linear relation A set of ordered pairs that give a straight line

Litres (L) A unit of capacity where $1 \text{ L} = 1000 \text{ mL} = 1000 \text{ cubic centimetres}$

Loss The amount of money lost by selling something for less than its cost

Lowest common denominator (LCD) The lowest common multiple of the denominators of a set of fractions

M

Mark-up An amount added by the retailer to the cost price of goods

Mean (\bar{x}) The average value of the scores in a set of data

Median The middle score (or mean of two middle scores) when a set of data is arranged in order

Midpoint The point on a line segment that is an equal distance from each of the end points of the segment

Millilitres (mL) A unit of capacity where $1 \text{ L} = 1000 \text{ mL}$

Mixed number A combination of a whole number and a fraction

Mode The most frequently occurring value in a set of data

N

Negative To be less than zero

Net A diagram showing how the plane faces of a solid are joined to each other

Net income Income that remains after deductions have been made

Non-convex (polygon) A polygon with at least one reflex angle

Numerator Parts of the whole. The part of a fraction that sits above the dividing line.

O

Obtuse angles Between 90 and 180 degrees

Opposite (side) In a right-angled triangle, the side opposite the unknown angle

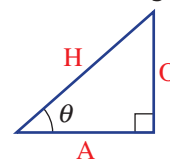

Origin The point (0, 0) where the x - and y -axes of the Cartesian plane intersect

Outcome One of the possibilities resulting from a chance experiment

Outlier Any value that is much larger or much smaller than the rest of the data in a set

Overtime Time worked in addition to normal working hours

P

Parabola A smooth U-shaped curve

Parallel Lines that are side by side and always have the same distance between them

Parallelogram A quadrilateral with two pairs of parallel sides

Per annum (p.a.) Annually; that is, per year

Percentage A number expressed as a part of 100

Percentage frequency histogram A special type of histogram that shows the frequencies of the data as percentages of the total

Perfect square An algebraic expression that can be written as a single square

Perimeter The total distance (length) around the outside of a figure

Perpendicular To be at right angles (90 degrees)

Pi A special number (3.14159...) which connects a circle's radius with its circumference and area

Pie chart A circular graph showing sectors which represent statistical categories

Polygon A two-dimensional shape where three or more straight lines are joined together to form a closed figure

Positive To be greater than zero

Power An expression that includes an index

Prime A number with two factors

Principal An amount of money invested in or loaned to a person or organisation

Prism A solid with a uniform cross-section and the remaining sides parallelograms

Probability A measure of the likelihood that an event will occur

Profit The amount of money made by selling something for more than its cost

Pronumeral A letter or symbol used to represent a number (also called a variable)

Proper fraction A fraction where the numerator is smaller than the denominator

Pythagoras' theorem In a right-angled triangle, the square of the hypotenuse is equal to the sum of the squares on the other two sides

Q

Quadrant A quarter circle or one quarter of a Cartesian plane

Quadratic relation An equation with a squared term but no term with a higher power

Quadrilateral A four-sided plane figure with straight sides

R

Radius The distance from the centre of a circle to its outside edge

Range The difference between the highest score and the lowest score in a set of data

Rate The number of units of one quantity for each single unit of another quantity

Ratio A way of comparing quantities of the same unit, separated by a colon

Rational number A real number that can be expressed as a fraction

Real numbers Any positive or negative number or zero

Reciprocal An inverted fraction

Rectangle A parallelogram with two pairs of equal sides and all angles 90 degrees

Recurring decimal A decimal with an infinite repeating pattern

Reflex angle Between 180 and 360 degrees

Regular polygon A polygon with all sides equal and all angles equal

Repayment An amount paid to a financial institution at regular intervals to repay a loan, with interest included

Retainer A set weekly or monthly fee paid to an employee

Revolution 360 degrees

Rhombus A parallelogram with four equal sides

Right-angled Containing an angle of 90°

Right prism A solid with a uniform cross-section, and remaining sides are rectangles

Rise The change in value in the vertical direction

Run The change in value in the horizontal direction from left to right

S

Salary A fixed agreed yearly amount that an employee earns

Sample space The list of all the possible outcomes of an event

Scale factor The number by which you multiply each side length to enlarge or reduce the size of a shape

Scalene triangle A triangle with three different side lengths

Scientific notation A method used to express very large and very small numbers

Sector A portion of a circle formed by an arc and two radii

Selling price The price for which a retailer sells goods to a buyer

Semicircle Half a circle

Significant figure A digit that indicates how accurate a number is

Similar figures Figures of the same shape but not the same size

Simple interest The percentage rate per year that is paid on a loan or investment amount

Sine The ratio of the length of the opposite side to the length of the hypotenuse

Skewed data Scores in a set of data that are unevenly distributed around either side of the mean and the median

Solid A three-dimensional shape with volume

Solution The answer

Solve To find the answer

Square (geometry) A parallelogram with four equal sides and all angles 90 degrees

Square (number) A number multiplied by itself

Square root The number that when squared produces the number under the square root sign

Straight angle 180 degrees

Stem-and-leaf plot A visual representation of data that groups the scores in a set of data and lists them in order horizontally

Subject The pronumeral that is alone on the left hand side (LHS) in an equation or formula

Substitute To replace pronumerals with numerical values

Substitution To replace a pronumeral with a number

Supplementary angles Angles that sum to 180 degrees

Surd An irrational number expressed using a radical sign (root)

Survey A set of questions or other activity designed to collect data

Symmetrical data A distribution of data that is balanced on either side of the mean and the median

T

Tangent The ratio of the length of the opposite side to the length of the adjacent side

Taxable income Gross income minus tax deductions

Term A combination of numbers and pronumerals connected with only multiplication and division

Time and a half A pay rate of overtime that is 1.5 times the normal hourly rate

Total surface area The number of square units needed to cover the outside of a solid

Transpose To rearrange a formula to make a different variable the subject

Transversal A line that cuts two or more lines

Trapezium A quadrilateral with one pair of parallel sides

Tree diagram A diagram used to show all the possibilities when several different options are available

Triangle A three-sided shape

Trigonometric ratio The ratios that relate the sides and angles of right-angled triangles

Turning point The point at which a curve changes direction

Two-step experiment A multi-stage experiment involving two steps

Two-way table A table used to organise, display and compare two sets of outcomes

U

Uniform With a constant cross-section

Unitary method A way of solving a problem by reducing one of the units to 1

V

Variable An unknown, which can take on any value

Venn diagram A diagram using overlapping circles to organise and show two or more sets of outcomes

Vertical Such that the top is directly above the bottom, at right angles to the horizontal

Vertically opposite Equal angles opposite at a point formed by intersecting lines

Volume The amount of three-dimensional space inside an object

W

Wage Earnings paid to an employee based on an hourly rate

With replacement Selecting items and replacing them before the next selection

Without replacement Selecting items and not replacing them before the next selection

X

x -axis The horizontal axis of the Cartesian plane

x -coordinate The first coordinate of an ordered pair, describing the horizontal position from the origin

x -intercept The point at which a line or curve cuts the x -axis

Y

y -axis The vertical axis of the Cartesian plane

y -coordinate The second coordinate of an ordered pair, describing the vertical position from the origin

y -intercept The point at which a line or curve cuts the y -axis

Answers

Chapter 1

Warm-up quiz

1 Addition: **a** Sum, **b** Total, **i** Add, **l** More than
 Subtraction: **c** Less than, **g** Take away, **h** Difference, **k** Minus
 Multiplication: **d** Lots of, **e** Product, **j** Times
 Division: **f** Into, **m** Quotient

- 2 **a** 4 **b** 32 **c** 4 **d** 52 **e** 74
 f 5 **g** 9 **h** 40
- 3 **a** 56 **b** 100 **c** 0 **d** 133 **e** 63
 f 80 **g** 1020 **h** 53
- 4 **a** -12 **b** -3 **c** 3 **d** 0
 e -1 **f** -1 **g** 0 **h** -12
- 5 **a** 3 **b** 3 **c** - **d** +
- 6 **a** 26 073 260 **b** 26 073 300 **c** 26 073 000
 d 26 000 000
- 7 **a** 50 **b** 5 **c** 5000
 d $\frac{5}{10}$ **e** $\frac{5}{100}$ **f** $\frac{5}{1000}$
- 8 **a** 2.654, 2.645, 2.564, 2.465
 b 0.654, 0.564, 0.456, 0.0456
- 9 **a** 7.99 **b** 10.11 **c** 7.11
- 10 **a** 1.4 **b** 0.06 **c** 3.68
 d 16.38 **e** 3.7 **f** 180
- 11 **a** 34.5 **b** 374 000
 c 0.03754 **d** 0.000037754
- 12 **a** 6 **b** 12 **c** 30 **d** 1
- 13 **a** 15 **b** 12 **c** 10
- 14 **a** $\frac{5}{7}$ **b** $1\frac{1}{4}$ **c** 8 **d** $\frac{3}{8}$

1A _____

Now you try

Example 1

a -3 **b** -10

Example 2

4

Example 3

-8

Exercise 1A

- 1 **a** iii **b** v **c** iv **d** i **e** ii
 2 **a** iv **b** ii **c** v **d** i **e** iii
 3 **a** T **b** T **c** F
 4 **a** -2 **b** 2 **c** -3 **d** 4 **e** -4
 f -5 **g** -2 **h** 0 **i** -6

- 5 **a** 3 **b** 2 **c** 1 **d** 0 **e** -1
 f -9 **g** -1 **h** -17 **i** -10 **j** 9
 k -2 **l** 11 **m** -7 **n** -18 **o** -1
- 6 **a** 5 **b** 20 **c** -20 **d** 0 **e** -7
 f 6 **g** -24 **h** 5 **i** -15
- 7 **a** 4 **b** -4 **c** -4 **d** -9 **e** -32
 f -38 **g** -189 **h** -24 **i** -18 **j** 0
 k -805 **l** -57 **m** -167 **n** 142 **o** -804
- 8 **a** -2 **b** 4 **c** 13 **d** 9
 e 24 **f** 0 **g** -28 **h** -81
 i 180 **j** 2 **k** -3 **l** 240
 m 755 **n** 94 **o** 10
- 9 **a** -27 **b** -3 **c** 10 **d** 26 **e** 0
 f -24 **g** -91 **h** 125
- 10 **a** 2 **b** 11 **c** -3
 d -1 **e** -7 **f** 11
- 11 **a** -8 **b** 4 **c** 13 **d** 124
 e -19 **f** 0 **g** -22 **h** 98
 i -26
- 12 -12°C

13 **a**

-8	6	-4
2	-2	-6
0	-10	4

b Example answer (other answers are possible):

2	-13	8
5	-1	-7
-10	11	-4

c

5	-2	7	3
0	10	-3	6
-1	4	2	8
9	1	7	-4

1B _____

Now you try

Example 4

a 32 **b** -35

Example 5

a 64 **b** -27

Example 6

a -5 **b** 4

Example 7

12

Exercise 1B

- 1 a Positive b Negative c Positive
 d Negative e Negative
- 2 a Negative b Negative c Negative
 d Positive e Positive f Positive
- 3 a T b F c T
- 4 a -48 b -20 c -72 d 72
 e 45 f -90 g -600 h 81
 i -144 j -143 k -143 l -34
 m 72 n 90 o -108
- 5 a 36 b 64 c 144 d 9 e 100
 f 169 g -8 h -1 i -64
- 6 a -9 b 6 c 10 d -10
 e 3 f 5 g 2 h -1
 i -8 j 25 k -104 l 5
 m -37 n -214 o 13
- 7 a 16 b -26 c -12 d -14
 e -20 f -28 g -72 h -8
 i -90 j 10 k -24 l -18
 m 9 n -26
- 8 a 7 b -32 c -20 d -4 e -1 f 6
 g -9 h -5 i -15
- 9 -5 and 2
- 10 a 12 and -12 b 8 and -8 c 100 and -100
- 11 Two negatives with \times and \div produce a positive.
- 12 a Positive b Positive c Negative
 d Positive e Negative f Positive
- 13 a -2 b -38 c -8 d 27 e 1
 f 24 g 21 h 0

1C

Now you try

Example 8

- a 107.39 b 0.03 c 2.80

Example 9

- a 3500 b 1800 c 0.0023

Example 10

10, reasonable as real answer is 9.5

Exercise 1C

- 1 a 3 b 1 c 2 d 0
 2 a 2 b 4 c 1 d 4
- 3 a Down b Up c Up
- 4 a 32 100 b 432 c 5.89
 d 0.443 e 0.00197
- 5 a 17.96 b 11.08 c 72.99 d 47.86
 e 63.93 f 23.81 g 804.53 h 500.57
 i 821.27 j 5810.25 k 1005.00
 l 2650.00
- 6 a 2400 b 35 000 c 0.060 d 34
 e 110 000 f 0.0025 g 2.1 h 0.71
 i 4700 j 59 000 k 0.46 l 1.1
- 7 a 1.46, 1.5 b 0.09, 0.094 c 23.71, 24
 d 0.01, 0.0078 e 100.47, 100
- 8 a 7 b 73 c 130 d 36 200
- 9 a 30 000 b 200 c 0.05 d 0.0006
 e 5000 f 900 g 0.9 h 0.0003 i 1
- 10 a 3600, 3693 b 760, 759.4
 c 4000, 4127.16 d 3000, 3523.78
 e 0, 0.72216 f 4, 0.716245
 g 0.12, 0.1186 h 0.02, 0.02254
 i 0.2, 0.2
- 11 a A: 54.3, B: 53.8, 0.5 b A: 54.28, B: 53.79, 0.49
 c A: 54, B: 54, 0 d A: 50, B: 50, 0
- 12 0.143 tonnes

- 13 As magnesium in this case would be zero if rounded to two decimal places rather than two significant figures
- 14 2.14999 is closer to 2.1 correct to one decimal place, \therefore round down
- 15 a i 8 ii 1 iii 8
 b 0.1428571428571
 c i 4 ii 2 iii 8
- 16 Teacher to check

1D

Now you try

Example 11

$\frac{5}{8}$, 0.32 and $-\sqrt{25}$ are rational numbers

Example 12

- a $3\frac{2}{5}$ b $\frac{9}{4}$

Example 13

2.3125

Example 14

0.41 $\dot{6}$

Example 15

- a $\frac{9}{20}$ b $3\frac{9}{40}$

Example 16

$\frac{4}{9} > \frac{5}{12}$

Exercise 1D

- 1 a T b F c T d T
- 2 a Proper b Mixed number
 c Improper d Proper
- 3 a $\frac{7}{10}$ b $\frac{3}{10}$ c $\frac{3}{2}$ d $\frac{7}{3}$
- 4 a, b, c, d, e, f, g, i, k
- 5 a i $2\frac{2}{5}$ ii $2\frac{5}{6}$ iii $5\frac{3}{4}$ iv $1\frac{1}{8}$
 b i $\frac{16}{5}$ ii $\frac{44}{7}$ iii $\frac{24}{5}$ iv $\frac{83}{8}$
- 6 a 2.75 b 0.35 c 3.4 d 1.875
 e 2.625 f 3.8 g 2.3125 h 0.25
- 7 a 0.27 b 0.7 c 1.285714 d 0.58 $\dot{3}$
 e 1. $\dot{1}$ f 3.8 $\dot{3}$ g 7.2 $\dot{6}$ h 2.6 $\dot{3}$
- 8 a $\frac{7}{20}$ b $\frac{3}{50}$ c $3\frac{7}{10}$ d $\frac{14}{25}$
 e $1\frac{7}{100}$ f $\frac{3}{40}$ g $3\frac{8}{25}$ h $7\frac{3}{8}$
- i $2\frac{1}{200}$ j $10\frac{11}{250}$ k $6\frac{9}{20}$ l $2\frac{101}{1000}$
- 9 a $\frac{5}{6}$ b $\frac{13}{20}$ c $\frac{7}{10}$ d $\frac{5}{12}$
 e $\frac{7}{16}$ f $\frac{11}{14}$ g $\frac{19}{30}$ h $\frac{11}{27}$
- 10 a $\frac{9}{20}$ b $\frac{3}{20}$ c $\frac{32}{45}$ d $\frac{23}{75}$
- 11 a $\frac{11}{6}, \frac{7}{3}$ b $\frac{2}{5}, \frac{2}{15}$ c $\frac{11}{12}, 1$ d $\frac{5}{7}, \frac{11}{14}$
- 12 Weather forecast
- 13 a $\frac{3}{5}$ b $\frac{5}{9}$ c $\frac{8}{13}$ d $\frac{23}{31}$

14 a 31, 32 b 36, 37, 38, ..., 55 c 4, 5
 15 a $\frac{8}{9}$ b $1\frac{2}{9}$ c $\frac{81}{99} = \frac{9}{11}$ d $3\frac{43}{99}$

1E _____

Now you try

Example 17

a $1\frac{1}{7}$ b $\frac{2}{5}$

Example 18

$\frac{19}{21}$

Example 19

a $4\frac{3}{8}$ b $\frac{8}{15}$

Exercise 1E

1 a 12 b 6 c 15 d 49 e 15
 f 35

2 a T b F

3 a $\frac{3}{10} + \frac{4}{10} = \frac{7}{10}$ b $\frac{4}{8} - \frac{3}{8} = \frac{1}{8}$ c $1\frac{2}{4} + \frac{1}{4} = 1\frac{3}{4}$

4 a 6 b 63 c 30 d 8 e 33
 f 60

5 a $\frac{3}{5}$ b $\frac{5}{8}$ c $\frac{7}{10}$ d $\frac{4}{7}$

e $\frac{5}{17}$ f $\frac{1}{5}$ g $\frac{10}{6} = 1\frac{2}{3}$ h $\frac{10}{8} = 1\frac{1}{4}$

i $\frac{7}{5} = 1\frac{2}{5}$ j $1\frac{4}{5}$ k $2\frac{1}{3}$ l $\frac{1}{2}$

m $\frac{2}{5}$ n $4\frac{1}{2}$ o $1\frac{2}{5}$ p $6\frac{1}{2}$

6 a $\frac{5}{8}$ b $\frac{1}{3}$ c $\frac{1}{2}$ d $\frac{1}{2}$

e $\frac{9}{10}$ f $\frac{7}{12}$ g $\frac{7}{10}$ h $\frac{3}{20}$

i $\frac{11}{24}$ j $1\frac{1}{6}$ k $1\frac{8}{21}$ l $\frac{17}{24}$

m $\frac{11}{36}$ n $\frac{4}{7}$ o $\frac{19}{100}$ p $\frac{19}{90}$

7 a $3\frac{5}{6}$ b $\frac{7}{12}$ c $2\frac{4}{5}$ d $2\frac{7}{12}$

e $6\frac{3}{4}$ f $3\frac{5}{6}$ g $\frac{1}{8}$ h $1\frac{5}{12}$

i $1\frac{7}{10}$ j $\frac{11}{12}$ k $4\frac{7}{10}$ l $1\frac{7}{12}$

8 $\frac{7}{8}$ tonnes

9 $5\frac{29}{56}$ tonnes

10 a $4\frac{19}{20}$ litres b 33

11 $\frac{1}{20}$

12 $\frac{5}{6}$, problem is the use of negatives in the method, since $\frac{1}{3} < \frac{1}{2}$

13 a i $\frac{1}{8} + \frac{3}{4}$ ii $\frac{2}{3} - \frac{5}{12}$ iii $\frac{5}{6} - \frac{1}{2}$

b $\frac{1}{2} + \frac{2}{3} + \frac{5}{6} = 2$

Progress quiz

1 a -8 b -14 c 25 d 8 e 4

f -3

2 a 42 b -60 c -8 d 8 e -64

f 81

3 a -9 b 19 c -7

4 a i 24.19 ii -6.14 iii 7.60

b i 3.3 ii 240

iii 7900 iv 0.0079

5 a 100, 121 b 89.8, 93.17302

6 a 0.625 b 3.32 c 0.583 d $2.\overline{63}$

7 a $\frac{4}{5}$ b $\frac{9}{25}$ c $\frac{1}{250}$ d $4\frac{41}{200}$

8 $\frac{3}{8}, \frac{5}{12}, \frac{11}{24}$

9 a $\frac{5}{8}$ b $\frac{2}{21}$ c $3\frac{11}{20}$ d $1\frac{9}{20}$

10 $3\frac{7}{12}$

1F _____

Now you try

Example 20

a $\frac{12}{35}$ b $\frac{5}{18}$

Example 21

$4\frac{1}{5}$

Example 22

a $\frac{3}{2}$ or $1\frac{1}{2}$ b $\frac{9}{5}$ or $1\frac{4}{5}$

Exercise 1F

1 a T b F c T

2 a 12 b 4 c 12 d 180

3 a $\frac{4}{3}$ b 7 c $\frac{1}{6}$ d $\frac{3}{5}$

4 a $\frac{3}{20}$ b $\frac{4}{15}$ c $\frac{15}{28}$ d $\frac{1}{6}$ e $\frac{1}{20}$ f $\frac{2}{27}$

g $\frac{10}{17}$ h $\frac{3}{7}$ i $\frac{2}{5}$ j $\frac{2}{3}$ k $\frac{2}{5}$ l $\frac{4}{5}$

m $\frac{3}{4}$ n $\frac{2}{3}$ o $\frac{2}{9}$ p $\frac{3}{16}$

5 a $\frac{1}{2}$ b $1\frac{1}{4}$ c $2\frac{1}{10}$ d 2 e $4\frac{1}{5}$

f $\frac{6}{7}$ g $6\frac{1}{4}$ h 4 i $2\frac{11}{12}$ j 6

6 a $\frac{20}{21}$ b $1\frac{1}{8}$ c $\frac{45}{56}$ d $\frac{27}{28}$

e $1\frac{1}{3}$ f $1\frac{1}{2}$ g 6 h $\frac{7}{8}$

i 18 j 9 k $\frac{1}{10}$ l $\frac{4}{27}$

7 a $3\frac{1}{3}$ b 4 c $\frac{1}{6}$ d $1\frac{1}{2}$ e $\frac{7}{8}$ f 27

8 a \$10 b \$3.50 c \$6 d \$18 e \$6400 f 90c

9 a $\frac{2}{7}$ b $\frac{8}{15}$ c 16

10 $\frac{3}{12}$ hour = 15 minutes

11 160 km

12 90 minutes each

- 13 a i 0.5 ii 0.2 iii 0.16129...
 iv 0.6 v -1
 b 3.39
 c 25
 d Numbers greater than zero but less than one
 e 1
 f 0

1G

Now you try

Example 23

5:3

Example 24

- a 25:16 b 26:15

Example 25

7:40

Example 26

\$350

Exercise 1G

- 1 a No b Yes c Yes d No

2	a	1:3	1:4
	b	2:3	2:5
	c	1:2	1:3

- 3 a 5:1 b 1:2 c 2:1 d 10:1
 e 5:16
- 4 a 1:5 b 2:5 c 4:5 d 1:10
 e 5:6 f 1:3 g 3:1 h 2:3
 i 4:3 j 4:1 k 1:2 l 3:1
 m 5:14 n 1:2:4 o 3:6:2
- 5 a 1:2 b 3:41 c 5:32 d 1:3
 e 1:5 f 10:3 g 40:1 h 1500:1
 i 20:7
- 6 a 3:4 b 8:3 c 9:20 d 45:28
 e 3:14 f 22:39
- 7 a 1:10 b 1:5 c 2:3 d 7:8
 e 25:4 f 1:4 g 1:4 h 24:5
 i 4:20:5 j 4:3:10 k 5:72 l 3:10:40
- 8 a \$100, \$400 b \$16, \$20
 c 24 kg, 64 kg d \$56, \$40
 e \$200, \$300 f 750 g, 1250 g
 g \$70, \$30 h \$300, \$300
 i \$14, \$49, \$7 j 336 g, 84 g
- 9 126 g
- 10 120
- 11 \$3000, \$1200, \$1800 respectively
- 12 108 L
- 13 Amy: \$2400, Belinda: \$3600, Candice: \$1200, Diane: \$4800
- 14 a i 100 mL ii 200 mL
 b i 250 mL ii 270 mL
 c i 300 mL ii 1:4
 d i 1:3 ii 7:19
 iii 26:97 iv 21:52
 e Jug 3 and 4

1H

Now you try

Example 27

- a \$30/h b 1200 revs/min

Example 28

- a 60 km/h b 4 hours 10 minutes

Example 29

The 3 L is cheaper

Example 30

1.6 L

Exercise 1H

- 1 a 60 km/h b \$84/h c 60 km/h
 2 a \$4 b \$3 c \$2.50
 3 a 10 m/s b 60 km/h c 14 km/h
 4 a \$84 b \$21 c \$126
 5 a \$28/h b \$50/h c 6 kg/min
 d \$7/kg e 4 runs/over f 89 pts/game
 g 19 cm/y h 14 m/s i 92 beats/min
 j 8 mL/s
 6 a 70 km/h b 15 km/h c 4 km/h
 d 54 km/h e 80 km/h
 7 a 13 hours b 16 hours 15 minutes
 8 a 3 kg deal b Red delicious c 2.4 L d 0.7 GB
 9 a i 130 words ii 325 words iii 3900 words
 b i 44 g ii 220 g
 c \$20 000
 d \$180
- 10 a 55 km b $16\frac{1}{2}$ km c $5\frac{1}{2}$ km
- 11 a Coffee A: \$3.60, coffee B: \$3.90. Therefore, coffee A is the best buy.
 b Pasta A: \$1.25, pasta B: \$0.94. Therefore, pasta B is the best buy.
 c Cereal A: \$0.37, cereal B: \$0.40. Therefore, cereal A is the best buy.
- 12 a 40 sheep/h b 220 sheep c 25 hours
- 13 a 1 080 000 000 km/h b 36 000 000 km
 c $8\frac{5}{18}$ min
- 14 a Yes b No c Yes d Yes e Yes
- 15 a
- | | | | | | | | | | |
|----------------|---|----|----|----|----|-----|-----|-----|-----|
| Time in hours | 0 | 1 | 2 | 3 | 4 | 5 | 6 | 7 | 8 |
| Distance in km | 0 | 20 | 40 | 60 | 80 | 100 | 120 | 140 | 160 |

b 20 km/h

c, e

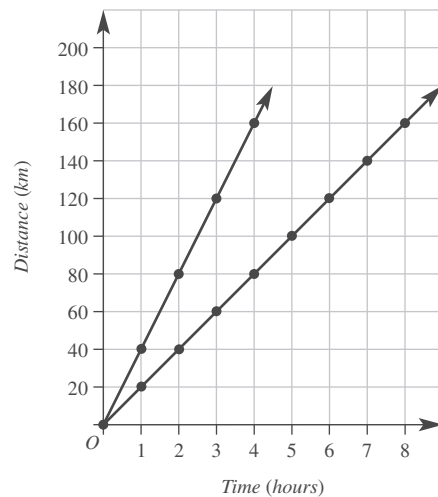

d Straight line, speed was constant

Maths@Work: Cooks and chefs

- 1 a 3:4 b 9 egg whites c 5 egg whites
 d 20 servings e 216 g f 45 g

- 2 a 3 loaves b 6 cartons
 c 3:5 d 1350 grams e 6:5
 f Recipe for 1 large loaf of banana bread:
 3 cups of plain flour
 1½ cups sugar
 1 teaspoon of bicarb of soda
 375 grams of melted butter
 3 eggs
 3 $\frac{1}{3}$ mashed bananas
- 3 a i 2:1 ii 1:25 iii 2:1
 b 8 eggs
 c 2 $\frac{1}{2}$ cups
- 4 3.5
- 5 a i 150 mL oil ii 2.5 cups flour
 iii 250 g chocolate
 b i 4 eggs ii 8 tablespoons apple sauce
 iii 640 g brown sugar

Puzzles and games

- 1 $1 + 2 + 3 + 4 + 5 + 6 + 7 + (8 \times 9) = 100$
 2 48 ways

3

1.	2.	3.	
9	2	5	3
4.		5.	6.
3	5	5	6
7.	8.	9.	
9	9	2	4
10.			
1	2	8	0

- 4 a i $1 + 2 + 3 = 6$ ii $28(1 + 2 + 4 + 7 + 14 = 28)$
 iii $1 + 2 + 4 + 8 + 16 + 31 + 62 + 124 + 248 = 496$
 b i
-
- 6 10 15 21
- ii 28, 36
 c i 0, 1, 1, 2, 3, 5, 8, 13, 21, 34
 ii $-21, 13, -8, 5, -3, 2, -1, 1, 0, 1, \dots, \therefore -21, -8, -3, -1$

Short-answer questions

- 1 a 8 b -45 c 270
 d -64 e 6 f 8
- 2 a 21.5 b 29 100 c 0.153 d 0.00241
- 3 a 14.98 b 0.71 c 2.00
- 4 a 2.125 b 0.8 $\dot{3}$ c 1.857142
- 5 a $\frac{3}{4}$ b $1\frac{3}{5}$ c $2\frac{11}{20}$
- 6 a $\frac{4}{3}$ b $\frac{5}{1} = 5$ c $\frac{1}{8}$ d $\frac{7}{9}$
- 7 a $\frac{1}{2}$ b $2\frac{1}{6}$ c $\frac{7}{24}$ d 2
- e $3\frac{3}{4}$ f $2\frac{19}{28}$
- 8 a 5:2 b 16:9 c 75:14
- 9 a 50, 30 b 25, 55 c 10, 20, 50
- 10 a Store A: \$2.25/kg; store B: \$2.58/kg. Store A is the best buy.
 b Store A: 444 g/\$; store B: 388 g/\$
- 11 \$132, \$198, \$330
- 12 a 32 b 7 c 192 d \$14.80 e 82.5
- 13 a 156 km/h b 36 km/h

- 14 \$6000
 15 36 m
 16 Doubles the perimeter

Multiple-choice questions

- 1 D 2 B 3 C 4 A 5 E
 6 E 7 D 8 E 9 C 10 B
 11 C 12 C 13 B

Extended-response questions

- 1 a 12 b 10 boys, 18 girls c 5:9
 2 a 85.6 km/h b 14 hours c 61.1 km/h d 611 km

Chapter 2

Warm-up quiz

- 1 a $\frac{3}{25}$ b $\frac{1}{5}$ c $\frac{7}{20}$ d $\frac{3}{4}$
 e $\frac{3}{5}$ f $\frac{1}{2}$
- 2 a 99 b 58 c 90 d 122
 e 8 f 150
- 3 a 55% b $\frac{3}{4}$ c 98%
- 4 a 61 b 9 c 37 d 121
 e 1 f 75, 4

5

Fraction	Decimal	Percentage
$\frac{1}{100}$	0.01	1%
$\frac{1}{10}$	0.1	10%
$\frac{1}{4}$	0.25	25%
$\frac{1}{2}$	0.5	50%
$\frac{3}{4}$	0.75	75%

- 6 a 10 g b 7 km c \$45 d \$800
 e 50 c f 9 c
- 7 a \$100 b 60 m c \$1.50 d \$67.80
 e 6 days f 3 days
- 8 a 100 b 10 c 20 d 3 e 4
- 9 2100 km
 10 25% of 100
 11 a 7 b 365 c 52 d 12
 12 a 14 b 6 c 12.5

2A

Now you try

Example 1

- a 55% b $\frac{1}{8}$

Example 2

- a 23% b 0.48

Example 3

25%

Exercise 2A

1 a multiply b divide c multiply d divide

	10%	20%	25%	50%	75%	$33\frac{1}{3}\%$	$66\frac{2}{3}\%$
Fraction	$\frac{1}{10}$	$\frac{1}{5}$	$\frac{1}{4}$	$\frac{1}{2}$	$\frac{3}{4}$	$\frac{1}{3}$	$\frac{2}{3}$
Decimal	0.1	0.2	0.25	0.5	0.75	0.3	0.6

3 a 25% b 50% c 100% d 40%

4 Sarah, $79\% > \frac{38}{50} = 76\%$

5 a 20% b 80% c 80% d 30%
 e 25% f $12\frac{1}{2}\%$ g 75% h 60%

i 56% j 35% k 9% l $7\frac{1}{2}\%$

6 a $\frac{19}{100}$ b $\frac{23}{100}$ c $\frac{99}{100}$ d $\frac{1}{20}$

e $\frac{11}{50}$ f $\frac{9}{20}$ g $\frac{37}{50}$ h $\frac{3}{4}$

i $\frac{1}{40}$ j $\frac{69}{400}$ k $\frac{1}{100}$ l $1\frac{1}{4}$

7 a 78% b 95% c 65% d 48%

e 75% f 142% g 7% h 30%

i 3% j 104% k 12% l 12.25%

8 a 0.12 b 0.83 c 0.57 d 0.88

e 0.99 f 1.0 g 1.2 h 0.05

9 a 2.5% b 10% c 5% d 5%

e 20% f 20% g 200% h 75%

Sport	Number of students who chose sport	Fraction of the total	Percentage of the total
Swimming	44	$\frac{22}{75}$	$29\frac{1}{3}\%$
Golf	12	$\frac{2}{25}$	8%
Volleyball	58	$\frac{29}{75}$	$38\frac{2}{3}\%$
Cricket	36	$\frac{6}{25}$	24%
Total	150	1	100%

11 31.5%

12 $16\frac{2}{3}\%$

13 $6\frac{1}{4}\%$

14 Yes, 2.8% fat content

15 Answers will vary.

2B _____

Now you try

Example 4

\$10.80

Example 5

\$500

Exercise 2B

1 a True b False c False d True

2 a 12 b 9 c 6

3 a \$400 b \$750

4 a 2 b 10 c 8 d 7.5

e 57.6 f 34 g 1230 h 42

i 450 j 33 k 198 l 1.5

5 a \$36 b \$210 c 48 kg d 30 km

e 15 apples f 350 m g 250 people

h 200 cars i \$49

6 a \$120 b \$700 c \$300 d \$7

e \$0.20 f \$450 g \$800 h \$360

7 a \$540 b \$600 c \$508 d \$1250

e \$120 f \$40

8 a \$5.80 b \$4.20 c \$0.46 d \$0.50

e \$44 f \$40

9 64

10 a Divide by 10. b Divide by 2.

c Divide by 2 and then 2 again (or just 4).

11 48 kg

12 15 students

13 $\frac{10}{100} \times 24 = \frac{24}{100} \times 10$; can multiply in any order

14 $x = 2, y = 24$

15 a 72 b $\frac{10}{11}$ c 280%

d $3\frac{1}{4}$ e 150%

2C _____

Now you try

Example 6

\$156

Example 7

\$54.40

Example 8

a 40% b 16.0%

Example 9

\$8.85

Exercise 2C

1 a 1.4 b 1.26 c 60% d 21%

2 a 0.8 b 0.27 c 6% d 69%

3 a 25% b 200%

4 a 61.6 b 1176 c 112 d 934.5 e 207
 f 540 g 12 h 196

5 a 76 b 540 c 22.5 d 616 e 7360

f 337.5 g 17 h 8910 i 0 j 9850

6 20%

Original amount	New amount	Increase	Percentage change
40	60	20	50%
12	16	4	$33\frac{1}{3}\%$
100	125	25	25%
24	30	6	25%
88	100	12	13.6%

b

Original amount	New amount	Decrease	Percentage change
90	81	9	10%
100	78	22	22%
20	15	5	25%
24	18	6	25%
150	50	100	$66\frac{2}{3}\%$

- 8 a \$3 b \$80 c \$200 d \$500
 e \$12 500
- 9 \$1785
- 10 \$84 634.25
- 11 24 534 cars
- 12 50%
- 13 28%
- 14 \$21.50
- 15 \$10.91
- 16 a \$900 b \$990
 c As 10% of 1000 = 100 but 10% of 900 = 90
- 17 a \$594 b \$3235.65
 c \$189 d \$61.48
- 18 a 79.86 g b \$97 240.50
 c \$336 199.68 d 7.10 cm

2D

Now you try

Example 10

\$1488

Example 11

\$52

Example 12

a \$13.50 b 37.5%

Example 13

\$220

Exercise 2D

- 1 a C b D c A d B
- 2 \$3 profit, \$2.50 loss, \$65.95 loss, \$1180 profit
- 3 40.95, 179.95, 799.95, 8995
- 4 28, 7.25, 199, 2037

5

Item	Cost price	% mark-up	Selling price
Jeans	\$60	28%	\$76.80
Toaster	\$40	80%	\$72
Car	\$22 000	45%	\$31 900
Can of drink	\$1.20	140%	\$2.88
Loaf of bread	\$1.80	85%	\$3.33
Handbag	\$80	70%	\$136
Tablet	\$320	35%	\$432

6

Item	Cost price	% discount	Selling price
Camera	\$900	15%	\$765
Car	\$24 000	20%	\$19 200
Bike	\$600	25%	\$450
Shoes	\$195	30%	\$136.50
Blu-ray player	\$245	50%	\$122.50
Electric razor	\$129	20%	\$103.20
Lawn mower	\$880	5%	\$836

7 a

Cost price (\$)	Selling price (\$)	Profit (\$)	Profit (%)
10	15	5	50%
24	30	6	25%
100	150	50	50%
250	255	5	2%
17.50	20	2.50	14.29%

b

Cost price (\$)	Selling price (\$)	Loss (\$)	Loss (%)
10	8	2	20%
16	12	4	25%
100	80	20	20%
34	19	15	44.12%
95	80.75	14.25	15%

- 8 a \$5.50 b \$200 c \$1500 d \$125
- 9 a i \$2 ii 20%
 b i \$5 ii 25%
 c i \$16.80 ii 14%
 d i \$2450 ii 175%
- 10 \$1001.25
- 11 42.3%
- 12 \$613.33
- 13 a \$400 b \$900 c \$765 d No
- 14 a \$350 000
 b i 71.4% ii 157.1% iii 114.3%
 c 25%

2E

Now you try

Example 14

a \$1484.62 b Ben c \$58 500

Example 15

a \$36 b \$48 c \$720

Example 16

\$8500

Exercise 2E

- 1 a C b D c B d A
- 2 a \$25.40 b \$101.60 c \$482.60
- 3 a \$36 b \$48
- 4 a \$11 406.25 b \$2632.21 c \$375
- 5 a \$1115.38 b \$29.35/h, therefore less c \$17 264
- 6 a \$41 080 b \$3423.33 c \$19.75

Employee	Hourly rate	Hours worked	Income
Adam	\$20.40	8	\$163.20
Betty	\$15.50	$8\frac{1}{2}$	\$131.75
Ceanna	\$19.70	15	\$295.50
David	\$24.30	38	\$923.40
Edward	\$57.85	42	\$2429.70
Francis	\$30	27	\$810
George	\$35.20	7.25	\$255.20

- 8 a \$262.80 b \$379.60 c \$584
 d \$876 e \$817.60 f \$1284.80

Person	Weekly retainer	Rate of commission	Commission earned	Weekly wage
Andrew	\$0	12% on \$7000	\$840	\$840
Byron	\$160	8% on \$600	\$48	\$208
Cindy	\$300	5% on \$680	\$34	\$334
Deanne	\$260	5% on \$40 000	\$2000	\$2260
Elizabeth	\$500	8% on \$5600	\$448	\$948
Faruq	\$900	2% on \$110 000	\$2200	\$3100
Gary	\$1000	1.5% on \$45 000	\$675	\$1675

- 10 a 7 b 18 c 33
 11 \$29 per hour
 12 \$24.40 per hour
 13 \$490
 14 \$5010
 15 \$1678.10
 16 a \$751.64 b \$151.64 c 7 hours

Progress quiz

- 1 a $\frac{8}{25}$ b 0.07 c 23% d 12.5%
 e 35% f $\frac{9}{200}$
 2 a 10% b 80% c 12.5%
 3 a 16 km b \$42 c 60 g d \$21
 4 a \$400 b \$300 c \$750
 5 a 90.2 b 237.6 c 93.5 d 235
 6 a 20% b 14.9%
 7 775
 8 a \$1392 b \$100.80
 9 61.3%
 10 a \$220 b \$65
 11 a \$1425 b \$400.40 c \$188.75
 d \$620

2F _____

Now you try

Example 17

- a \$4712 b 24% c \$64 712

Example 18

\$15 922

Exercise 2F

Gross income	Deductions	Net income
\$5600	\$450	\$5150
\$87 000	\$28 000	\$59 000
\$50 000	\$6700	\$43 300

- 2 \$1405
 3 \$25 000
 4 a Nil b \$3572 c \$17 547
 5 a i \$40 035 ii 17.0%
 b i \$53 905.80 ii 20.1%
 c i \$41 218.20 ii 15%
 d i \$30 052.56 ii 22.2%
 6 a \$1830 b \$8043 c \$12 617.50
 d \$23 772.80
 7 a \$19 656 b \$53 144
 8 a \$0 b \$2242 c \$7797 d \$17 547
 e \$35 677 f \$45 667 g \$63 547
 h \$198 547 i \$423 547
 9 \$67 400
 10 a \$51 200 b \$8187 c \$43 013 d \$1654.35
 11 \$360.21
 12 a 37 001 – 80 000 bracket b \$41393.84614 = \$41393.85
 13 a \$81 120 b \$17 961.40
 c \$63 158.60 d \$2429.18
 14 a \$78 560 b \$17 079
 c \$61 481 d \$2364.65
 15 \$32.26

2G _____

Now you try

Example 19

\$400

Example 20

\$618.75

Example 21

Interest = \$570
 Total = \$5570

Exercise 2G

- 1 a \$12 000 b 6% p.a. c 3.5 years
 2 a \$1120 b \$2800 c \$5600
 3 a \$3000 b \$3600 c \$416
 4 a \$300 b \$900 c \$1600
 d \$3150 e \$1196.25
 5 \$2700, \$17 700
 6 a \$52.50 b \$100 c \$40
 d \$264.38 e \$1027.40
 7 \$1980, \$23 980

8 a	\$840	\$7840
b	\$840	\$2340
c	\$1500	\$41 500
d	\$4550	\$74 550
e	\$200	\$2200

- 9 \$2560
 10 a \$3600 b \$18 000 c \$38 000
 11 Choice 2
 12 a \$645 b \$194 c \$129 d \$19
 e \$55 148 f \$12 320 g \$2580 h \$58 050
 i \$129 000
 13 a i \$12 ii \$31 iii \$10
 b i \$335 ii \$500 iii \$235

Now you try

Example 22

2.5 years or 2 years 6 months

Example 23

5% p.a.

Example 24

- a \$16800 b \$51800 c \$719.44

Exercise 2H

- 1 a 2 years b 4 years
 c 50 years d $2\frac{1}{2}$ years
- 2 5 years
 3 \$2400
 4 \$450
 5 3 years
 6 $4\frac{1}{2}$ years
 7 18 months
 8 a 6.25% b 2% c 6.5% d 5.5%
 e 21% f 3.5%

Interest	Total amount to be repaid	Monthly repayment
\$5250	\$10 250	\$170.83
\$10 500	\$24 500	\$408.33
\$2400	\$12 400	\$258.33
\$44 000	\$99 000	\$825
\$525 000	\$775 000	\$2152.78

- 10 \$2083.33
 11 a \$14 400 b \$240
 12 10%
 13 a \$P
 b 12.5%
 c i 20 years ii 40 years
 iii Double
 14 a Final amount = \$732.05 b \$232.05
 15 a \$5743.27
 b \$5743.27, same as final answer in part a.
 c Increases the amount by 5% five times, giving the same result
 d 5.5%

Maths@Work: Facebook cake-decorating business

- 1 \$294
 2 a 8 cm b 10 cm c 23 cm d 25 cm
 3 21%
 4 a White: 5 kg at \$40; Red: 2.5 kg at \$36.95; Blue: 500g at \$7.95
 b \$1.55/100g
 c When a specific quantity was required and any extra would be wasted
 5 a \$231 b 49% c 290%, 480%, 350%, 330%
 d \$26/h; \$44/h; \$32/h; \$30/h
 6 a \$427
 b Birthday – choc fudge mud; Birthday – caramel mud; Birthday – choc Jaffa
 c \$47/h wedding cake 3 tiers; \$46/h wedding cake 2 tiers; \$43/h child's theme birthday cake
 d The higher rate of pay for these cakes is due to their complexity requiring a higher level of skill for baking and decorating.

Puzzles and games

1

S	A	G	R	O	S	S	W	H	K	L	O	M
A	P	E	R	C	E	N	T	A	G	E	C	O
L	A	R	C	O	M	M	I	S	S	I	O	N
A	S	E	R	V	I	N	T	E	R	E	S	T
R	T	Y	H	E	T	S	L	O	S	S	T	H
Y	E	F	O	R	T	N	I	G	H	T	I	L
W	S	M	O	T	A	X	A	T	I	O	N	Y
E	I	O	L	I	D	I	D	N	P	Y	I	E
K	M	N	Q	M	O	N	T	R	N	I	S	C
E	P	Y	U	E	D	I	S	C	O	U	N	T
M	L	R	E	P	A	Y	M	E	N	T	A	H
D	E	D	U	C	T	I	O	N	S	I	X	L

2 EARTH, AIR, FIRE, WATER

Short-answers questions

1

Decimal	Fraction	Percentage
0.6	$\frac{3}{5}$	60%
0. $\dot{3}$	$\frac{1}{3}$	$33\frac{1}{3}\%$
0.0325	$\frac{13}{400}$	$3\frac{1}{4}\%$
0.75	$\frac{3}{4}$	75%
1.2	$1\frac{1}{5}$	120%
2	2	200%

- 2 a \$77.50 b 1.65
 3 a 150 b 25
 4 a 72 b 1.17 c 20%
 5 12.5 kg
 6 \$1800
 7 \$4375
 8 a \$25 b $16\frac{2}{3}\%$
 9 a \$38.50 b \$14.30
 10 \$50 592
 11 \$525
 12 3 years
 13 \$16 897

Multiple-choice questions

- 1 C 2 C 3 B 4 D 5 C
 6 C 7 C 8 A 9 C 10 E

Extended-response questions

- 1 a \$231
 b \$651
 c i \$63 ii \$34.65
 2 a \$25.68 b \$38.52 c \$154.08
 d 6.5 e \$46 547.31 f \$558.57

Chapter 3

Warm-up quiz

- 1 a $3x$ b $4ab$ c $10x$ d $21b$
 2 a 8 b 7 c 12 d 6
 e 9 f 14
- 3 a $x+3$ b ab c $2y-3$ d $\frac{x+2}{3}$
- 4 a -18 b -28 c 40 d 3
 e 3 f -5 g -4 h -8
- 5 a $3x$ b $6y+5$ c $8x$ d $17y$
 e $10a+9a^2$ f $5xy-7y$
- 6 a $6a$ b $-21xy$ c $4b$ d $\frac{3m}{2}$
- 7 a $2x+6$ b $3a-15$ c $8x+4$
- 8 a 1 b -2 c 5 d -6
- 9 b, c
- 10 a 9 b 10 c 4 d 21

3A

Now you try

Example 1

- a 4
 b i -2 ii 6
 c 5

Example 2

- a $g+5$ b $\$4x$ c $\frac{600}{y}$ mL

Example 3

- a $y+7$ b $2x-6$ c $\frac{m+n}{3}$ d $\sqrt{a+b}$

Example 4

- a 24 b -13 c 33

Exercise 3A

- 1 a expression b constant term
 c pronomeral d coefficient
 e terms
- 2 a $7y$ b $-2x$ c ab d $\frac{y}{2}$
 e $\frac{x}{y}$ f $\frac{2}{a}$
- 3 a 5 b 8 c 14 d 4
- 4 a Yes b No c Yes d No
- 5 a i 3 ii 2 iii 3
 b i 2 ii -3 iii 0
 c i 3 ii 7 iii -4
 d i 4 ii $\frac{1}{2}$ iii -1
- 6 a i $4+r$ ii $t+2$ iii $x+y+z$
 b i $\$6P$ ii $\$10n$ iii $\$2D$ iv $\$(5P+2D)$
 c $\frac{500}{C}$
- 7 a $2+x$ b $ab+y$ c $x-5$ d $2y-7$
 e $3x$ f $3p$ g $2x+4$ h $\frac{x+y}{5}$
 i $4x-10$ j $1-3x$ k $\frac{3+y}{2}$
 l $\frac{1}{2}(x+1)$ m $(m+n)^2$ n m^2+n^2

- 8 a 20 b 25 c 15 d 0 e 6
 f 5 g 28 h -96 i 5
- 9 a $60m^2$ b Length = $12+x$, width = $5-y$
 c $17+x-y$
- 10 a $\$26$ b $\$50$ c No d 12 hours
- 11 a 18 square units b 1, 2, 3, 4, 5
- 12 a $\frac{A}{20}$ b $\frac{3A}{20}$ c $\frac{nA}{20}$
- 13 a i $P=2x+2y$ ii $A=xy$
 b i $P=4p$ ii $A=p^2$
 c i $P=6+x+y$ ii $A=3x$
- 14 a i No ii No
 b i $3x+1$ or $3(x+1)$
 ii $5+\frac{x}{3}$ or $\frac{5+x}{3}$
 iii $\frac{1}{2}(x+y)$ or $\frac{1}{2}x+y$
- c Answers may vary.
 i The sum of 2 and x is multiplied by 4.
 ii 3 is added to a half of x .
 iii A third of the sum of m and n
 iv 7 more than 5 lots of x
 v The sum of x and y is divided by 2.
 vi The sum of b and a half of a

3B

Now you try

Example 5

- a $5m$ and $2m$ are like terms
 b $7y$ and $-y$ are like terms
 $4xz$ and zx are like terms

Example 6

- a $8t$ b $4y+3$

Example 7

- a $6a+13b$ b $3st+4s$ c $5x^2y-6xy$

Exercise 3B

- 1 a like b coefficients
 c pronomeral/variable d 1
- 2 a Y b N c N d Y
 e Y f N
- 3 a, c, d, f
- 4 a $4y$ and $2y$, $3xy$ and $7xy$ b $3x$ and $7x$
 c $7ab$ and $-3ab$, $2a$ and $5a$ d $2a^2$ and $-3a^2$, $4a$ and a
 e $3x^2y$ and $7yx^2$ f $5ab^2$ and $4ab^2$, $3ab$ and $7ba$
- 5 a $10a$ b $7n$ c $8y$ d $11x$
 e $4ab$ f $8mn$ g $7y+8$ h $3x+5$
 i $4m+2$ j $12ab+3a$ k $7xy+4y$ l $3bc-4$
- 6 a $5a+9b$ b $6x+5y$ c $5xy+4x$
 d $4t+6$ e $11x+4$ f $7mn-1$
 g $5ab-a$ h 0 i $10ac-9c$
 j $3xy^2$ k $3m^2n$ l $7x^2y-4xy$
 m $4x^2-3x$ n $4a^2b-3ab$ o $7pq^2-8pq$
- 7 a $x+y$ b $4x+2y$
- 8 a $4x+2y$ b $12s$ c $30x$ d $5x+4$
 e $6x+16$ f $12a+4b+4$
- 9 $8x$ metres
- 10 a $4t$ b $9x$ c $2x$ d $7a$
 e $5n$ f $4pq$ g $2xy$ h $3b$
- 11 a $3a+7b$ b 4 units each
 c a d $2a-b$

3C

Now you try

Example 8

a $20x$ b $-18mp$

Example 9

a $\frac{x}{3}$ b $\frac{9q}{2}$

Example 10

a $42a^2b$ b $5y$

Exercise 3C

- 1 a $7xy$ b 6 c $20x$ d 2
 2 a T b T c F d F
 e F f T
 3 a $10m$ b $12b$ c $15p$ d $6x$
 e $18pr$ f $16mn$ g $-14xy$ h $-15mn$
 i $-12cd$ j $30ab$ k $-24rs$ l $-40jk$
 4 a $4b$ b $\frac{a}{3}$ c $\frac{2ab}{3}$ d $\frac{m}{2}$ e $\frac{x}{4}$
 f $\frac{5s}{3}$ g 3 h $\frac{9q}{2}$ i $\frac{x}{2}$ j $6b$
 k $\frac{7m}{3}$ l $\frac{2}{5x}$
 5 a $24n^2$ b $-3q^2$ c $10s^2$ d $21a^2b$
 e $-15mn^2$ f $18gh^2$ g $3b$ h $5x$
 i $\frac{m}{2}$ j $\frac{1}{4y}$ k $\frac{3ab}{5}$ l $3pq$
 6 a $\frac{4x}{y}$ b $\frac{m}{3}$ c $\frac{2a}{b}$ d $\frac{10x}{y}$ e $8n$
 f $5b$ g 5 h $6xy$ i $\frac{p^2}{2}$ j $2ab$
 7 a $12ab$ b $4x^2$ c $10xy$ d $6x^2$
 8 $2x$
 9 a $4n$ b $7y$ c $9y$ d $5ab$
 e $14x$ f $10y$ g $12a$ h $8x^2y$
 i $10x^2$
 10 a i $3x^2 \text{ m}^2$ ii $5x \text{ metres}$
 b i 7500 m^2 ii 250 m
 11 a $4b$ b $2ab$ c b

3D

Now you try

Example 11

a $4x+8$ b $6x-60$

Example 12

a $-3x-21$ b $-5x+45$

Example 13

a $5a+20b$ b $15y^2-12y$

Example 14

a $7x+6$ b $18-2y$

Exercise 3D

- 1 a i $5x$ ii 10
 b $5x+10$
 c $x+2$

d $5(x+2)$

e $5x+10$

2 term, multiplied, inside

3C

4 a 3, 3, 15

b $-4, -4, -4x, 8$

5 a $2x+6$

b $5x+60$

c $2x+14$

d $7x+63$

e $3x-21$

f $6x-66$

g $5x-45$

h $10x-10$

i $6+3x$

j $21+7x$

k $28-4x$

l $40-5x$

6 a $-3x-6$

b $-2x-22$

c $-5x+15$

d $-6x+36$

e $-8+4x$

f $-39-13x$

g $-72-8x$

h $-300+300x$

7 a $2a+2b$

b $5a+10b$

c $6m+3y$

d $16x-40$

e $-12x-15$

f $4x^2-8xy$

g $2t^2-3t$

h $3a^2+4a$

i $2d^2-5d$

j $6b^2-10b$

k $8x^2+2x$

l $5y-15y^2$

8 a $2x+11$

b $6x+22$

c $5x+6$

d $3x+10$

e $4x-5$

f $2x+1$

g $8-3x$

h $21-5x$

i $-1-2x$

j $-3x$

k $3-x$

l $6-3x$

9 a $4x+4y$

b $8x+4$

c $2x-2$

10 a $2x+2$

b $8x-12$

c $6x^2+2x$

d $6x+15$

11 $2x+120$

12 a $2x+12$

b x^2-4x

c $-3x-12$

d $-7x+49$

e $5x+10+4=5x+14$

f $5-2x+14=19-2x$

13 a $x-10000$

b $0.2(x-10000)=0.2x-2000$

14 a $5x+12$

b $4x+6$

c $11x+7$

d $17x-7$

e $x-7$

f $2x-4$

g $3x^2+10x$

h $5x-3+x^2$

15 a $2x^2+4x$

b x^2+2x+6

c $20+8x-x^2$

3E

Now you try

Example 15

a $x=5$

b $x=3$

Example 16

a $x=-2$

b $x=-\frac{4}{5}$

Exercise 3E

1 c, d

2 a 6

b 8

c 4

3 a $2x=6$

b $3x=21$

c $x=9$

4 a Subtract 9 from both sides.

b Add 1 to both sides.

c Divide both sides by 3.

5 a $x=4$

b $a=1$

c $m=4$

d $x=4$

e $n=2$

f $x=-4$

g $b=3$

h $y=7$

i $a=4$

j $b=8$

k $x=-1$

l $y=2$

6 a $x=-3$

b $x=-1$

c $x=-2$

d $x=-8$

e $x=2$

f $x=2$

g $x=2$

h $x=6$

7 a $x=\frac{3}{2}$

b $x=\frac{3}{5}$

c $x=\frac{10}{11}$

d $x=\frac{1}{2}$

e $x=-\frac{1}{3}$

f $x=\frac{4}{5}$

8 a $x+8=34, x=26$

b $x-7=21, x=28$

c $2x+4=10, x=3$

d $3x-4=11, x=5$

e $3x-4=20, x=8$

f $25-2x=7, x=9$

9 a Added 2 on the right hand side rather than subtracting 2.

b Multiplied the right hand side by 2 in the last step rather than dividing by 2.

c The negative was dropped, $-x=7$ so $x=-7$.

d Needed to subtract 3 from both sides before dividing both sides by 2.

10 a $x=5$

b $x=-9$

c $x=-2$

11 a 10 s

b 8 s

3F

Now you try

Example 17

a $x = 8$ b $x = 30$

Example 18

$x = 17$

Exercise 3F

- 1 a 5 b $\frac{3}{4}$ c 2x
- 2 a 20 b 24 c 11 d 15
- 3 C
- 4 a iv, add 1 to both sides
b iii, multiply both sides by 4
c i, multiply both sides by 3
d ii, multiply both sides by 2
- 5 a $x = 15$ b $y = 14$ c $y = 10$ d $x = 4$
e $x = 8$ f $x = 2$ g $b = 12$ h $t = -6$
i $a = -6$ j $y = 30$ k $x = 15$ l $s = 4$
m $x = 12$ n $m = -4$ o $y = -35$
- 6 a $x = 11$ b $x = 6$ c $y = 2$ d $b = 0$
e $y = 20$ f $t = 39$ g $k = 57$ h $x = 70$
i $x = -10$ j $b = -24$ k $y = -22$
- 7 a $t = 3$ b $m = 40$ c $y = -2$
d $x = 19$ e $y = -6$ f $t = -\frac{3}{4}$
- 8 a $\frac{x}{3} = 12, x = 36$ b $\frac{2x}{5} = 4, x = 10$
c $\frac{x}{2} - 4 = 10, x = 28$ d $\frac{x+3}{4} = 6, x = 21$
e $\frac{7x}{3} = 8, x = \frac{24}{7}$ f $\frac{x}{3} + 5 = 16, x = 33$
- 9 21
- 10 a Needed to $\times 3$ before $-2, x + 2 = 21, x = 19$
b Need to $+4$ before $\times 3, \frac{x}{3} = 6, x = 18$
- 11 a $x = 12$ b $x = 12$ c $x = -4$ d $b = 6$
e $x = 5$ f $m = 5$ g $y = -1$ h $t = -7$
i $x = -3$
- 12 a $x = 9$ b $x = 36$ c $x = -7$ d $x = 8$
e $x = 5$ f $x = -10$
- 13 No, order does not matter for \times or \div . By dividing by 7 first you deal with smaller numbers, since 7 is a factor of 14.

Progress quiz

- 1 a 4 b -3 c 8
- 2 a $\$3d$ b $\frac{\$500}{x}$ c $3y - 4$ d $2(m + n)$
- 3 a -1 b -8 c 12
- 4 a $12x$ b $7b$ c $9a + 5$ d $8xy - 4x$
e $3a + 10b$ f $6mn - 3n$ g $2xy^2 - 2xy$ h $2a^2b + 7ab^2$
- 5 a $24b$ b $24ac$ c $-20xy$ d $28ab^2$ e $\frac{x}{4}$
f $\frac{3y}{4}$ g $\frac{3xy}{2}$ h $8x$
- 6 a $3x + 15$ b $4y - 4$ c $-2x - 10$
d $-5a + 10$ e $12x - 30y$ f $12m^2 + 3mn$
- 7 a $6x - 8$ b $-4x - 4$ c $2 - 2x$
- 8 a $x = 3$ b $x = 4$ c $x = -9$ d $x = -\frac{3}{5}$
- 9 a $x = 28$ b $x = 48$ c $x = 27$ d $x = -22$
- 10 a $3x + 5 = 32$, number is 9
b $\frac{x-3}{4} = 5$, number is 23

3G

Now you try

Example 19

$x = \frac{11}{3}$ or $3\frac{2}{3}$

Example 20

$x = 5$

Exercise 3G

- 1 a $3 \times \frac{x}{3} + 3 \times 7 = 25$
 $3x + 21 = 25$
b $4 \times 2x + 4 \times (-1) = 15$
 $8x - 4 = 15$
- 2 a $x + 2 = 3$ b $x - 3 = 5$ c $x + 6 = -4$
- 3 a $4x - 12$ b $2x - 15$ c $-2x + 8$
- 4 a $x = \frac{5}{2}$ or $2\frac{1}{2}$ b $a = \frac{3}{5}$ c $m = \frac{19}{3}$ or $6\frac{1}{3}$
d $y = \frac{47}{5}$ or $9\frac{2}{5}$ e $p = \frac{35}{4}$ or $8\frac{3}{4}$ f $k = \frac{19}{2}$ or $9\frac{1}{2}$
g $b = -\frac{1}{4}$ h $m = -\frac{11}{2}$ or $-5\frac{1}{2}$ i $x = -\frac{4}{5}$
j $a = \frac{1}{14}$ k $x = \frac{19}{6}$ or $3\frac{1}{6}$ l $n = \frac{2}{3}$
m $x = -\frac{1}{10}$ n $y = -\frac{1}{6}$
- 5 a $x = 1$ b $x = 2$ c $x = 2$ d $x = 12$
e $x = 3$ f $x = 1\frac{2}{3}$ g $x = -5$ h $x = -1$
- 6 a $x = 1$ b $x = 2$ c $x = 1$ d $x = 9$
e $x = -4$ f $x = 1$
- 7 a $3(x + 1) = 4, x = \frac{1}{3}$ b $2(x - 2) = 19, x = 11\frac{1}{2}$
c $2(x + 3) = 7, x = \frac{1}{2}$ d $3(x - 4) = 8, x = 6\frac{2}{3}$
e $2(3x - 2) = 5, x = 1\frac{1}{2}$ f $3(2x + 5) = 10, x = -\frac{5}{6}$
- 8 $\$5/\text{hour}$
- 9 a $x = 5$ b $x = 5$
c Dividing both sides by 3 is faster because $9 \div 3$ is a whole number
- 10 a $x = 4\frac{1}{3}$ b $x = 4\frac{1}{3}$
c Expanding the brackets is easier because $7 \div 3$ gives a fraction answer
- 11 a No b No c Yes, $4(x + 1) = 20$
d Yes, $2(x - 4) + 3x + 1 = 13$
e Yes, $3x + 2 + 2(x - 5) = 12$
f Yes, $2x - 3 - 3(x - 1) = -4$

3H

Now you try

Example 21

a $x = 4$ b $x = 3$

Example 22

a $x = 4$ b $x = 2$

Example 23

a $x = -4$ b $x = 8$

Exercise 3H

- 1 a Left b Left c Right d Right
- 2 a Subtract $3x$ from both sides.
b Subtract $5x$ from both sides.
c Add x to both sides.
d Add $2x$ to both sides.
- 3 a $2x = 6$ b $2x - 3 = 1$ c $5x = 1$
d $4 = 8 + 6x$
- 4 a $x = 4$ b $x = 3$ c $x = 3$ d $x = 7$
e $x = -3$ f $x = -2$ g $x = 2$ h $x = 4$
i $x = 6$ j $x = 2$
- 5 a $x = 8$ b $a = 3$ c $m = 8$ d $x = 4$
e $x = 5$ f $x = 3$ g $x = 1$ h $y = 2$
i $m = 3$ j $x = 3$ k $b = -1$ l $m = -3$
- 6 a $x = 7$ b $a = 5$ c $y = 2$ d $x = -14$
e $b = -16$ f $m = 3$ g $a = 19$ h $x = -3$
i $x = -13$ j $n = 14$ k $a = 2$ l $x = 2.5$
- 7 a $2x = 3x - 4, x = 4$ b $2x + 4 = 5x, x = 1\frac{1}{3}$
c $3x + 10 = 5x, x = 5$ d $3x + 2 = 5x - 6, x = 4$
e $2x - 1 = 3x + 5, x = -6$
f $2x + 4 = 13 - x, x = 3$
- 8 Mardy is 8 years old.
- 9 a $x = 4$ b $x = 4$
c Method a: don't have to deal with negatives
- 10 a 48 b 38 c 26 d 48

3I

Now you try

Example 24

5

Example 25

5 hours

Example 26

Max kicked 4 goals and Tim 7 goals

Exercise 3I

- 1 a iii b iv c i d ii
- 2 ii, v, iv, i, iii
- 3 age, $x + 4, x + 4, 2x, 30, 15$, Bernard is 15 and Sam is 19.
- 4 a 7 b 5 c 21 d 8 e 2
- 5 a Let d be the number of days the car is rented for.
b $50 + 40d = 290$ c $d = 6$
d The car was rented for 6 days
- 6 48 items
- 7 a Let e be the number of goals for Emma. b $e + 8$
c $e + e + 8 = 28$ d $e = 10$
e Emma scored 10 goals, Leonie scored 18 goals
- 8 a Let w be the width in centimetres. b Length = $4w$
c $2w + 2(4w) = 560$ d $w = 56$
e Length = 224 cm, width = 56 cm
- 9 Benita \$360, Adele \$640
- 10 Andrew \$102.50, Brenda \$175, Cammi \$122.50
- 11 Walked 10 km, ran 20 km
- 12 15 and 45
- 13 Rectangle $L = 55$ m, $W = 50$ m. Triangle side = 70 m
- 14 a 27, 28, 29
b i $x, x + 2, x + 4$ ii 4, 6, 8
15 a $T = 8x + 7200$ b 300
c $R = 24x$ d $x = 350$ e 3825

3J

Now you try

Example 27

- a 7 b 8

Example 28

- a $A = 3$ b $r = 3.2$

Example 29

a $a = \frac{v - u}{t}$ b $v = \sqrt{\frac{2E}{m}}$

Exercise 3J

- 1 Answers will vary, e.g. $A = hw, A = \frac{1}{2}bh, A = \pi r^2 \dots$
- 2 a A b D c M d A
- 3 a $x = \frac{b}{a}$ b $x = cd$ c $x = ab + d$
d $x = c^2$
- 4 a 21 b 24 c 2 d 6
e 452.39 f 33.51 g 25.06 h 14.95
i 249.86 j 80
- 5 a $F = 36$ b $w = 5$ c $t = 7.5$ d $v = 25$
e $r = 3.91$ f $a = 20$
- 6 a $d = \frac{C}{\pi}$ b $x = \frac{d - a}{b}$ c $n = \frac{p}{m} - x$ or $\frac{p - mx}{m}$
d $r = \frac{100I}{Pt}$ e $v = \sqrt{PR}$ f $h = \frac{A}{2\pi r}$
g $r = \sqrt{\frac{V}{\pi h}}$ h $A = (4C - B)^2$
i $a = \sqrt{c^2 - b^2}$ j $b = a^2 - c$
- 7 a 88.89 km/h
b i $d = st$ ii 285 km
- 8 a 35 m/s b 2 s
- 9 a Decrease b 3988 L c 417 min
- 10 a i 212°F ii 100.4°F
b i -10°C ii 36.7°C
- 11 a 73 b 7 c 40.025

Maths@Work: Plumber

- 1 a 6.3 L b 7.88 L c 18.75 L
d 15 L
- 2 a i 98.1 kPa ii 196.2 kPa
iii 294.3 kPa iv 392.4 kPa
b $h = \frac{P}{9.81}$
i 2.51 m ii 2.46 m iii 1.38 m iv 2.84 m
- 3 a 150 mm b 357 mm
c 150 mm d 333 mm

The number of drain pipes for a house			
House	Total roof catchment area m^2	Decimal number of downpipes	Whole number of downpipes
i	131	2.79	3
ii	147	3.27	4
iii	180.5	3.92	4
iv	257	5.47	6

Puzzles and games

- 1 $x = 3$

4	9	2
3	5	7
8	1	6

- 2 $5x^2 - xy$
 3 WORD
 4 Eric is 18 years old now.
 5 1st leg = 54 km, 2nd leg = 27 km, 3rd leg = 18 km, 4th leg = 54 km
 6 \$140
 7 a $x = \frac{12}{5}$ b $x = \frac{23}{2}$

Short-answer questions

- 1 a $x + y$ b $7m$ c $\$3m$ d $\frac{n-3}{4}$
 2 a 11 b 7 c 12 d 8
 e -11
 3 a $8n$ b $6xy$ c $4a$ d $\frac{xy}{3}$
 4 a $7b$ b $4x + 3$ c $3p + 2q$
 d $2m - 3mn + n$
 5 a $2x + 14$ b $-6x - 15$ c $6x^2 - 8x$
 d $-10a + 8a^2$ e $4x + 13$ f $3x - 7$
 6 a $x = 9$ b $x = 2$ c $x = -3$ d $x = -9$
 7 a $x = 10$ b $x = 8$ c $x = 26$ d $x = 6$
 8 a $2n + 3 = 21, n = 9$ b $\frac{l-5}{3} = 7, l = 26$
 c $\frac{x}{4} - 5 = 0, x = 20$
 9 a $x = 5$ b $x = \frac{11}{6}$ or $1\frac{5}{6}$
 10 a $x = 4$ b $x = 2$ c $x = 1$ d $x = -5$
 11 \$260
 12 a $E = 60$ b $a = 5$ c $h = \frac{10}{P}$
 13 a $x = \frac{v^2 - u^2}{2a}$ b $I = \sqrt{\frac{P}{R}}$

Multiple-choice questions

- 1 C 2 C 3 D 4 C 5 D 6 A
 7 B 8 B 9 B 10 D

Extended-response questions

- 1 a i \$85 ii \$110
 b i Let h be the number of hours of hire. ii $60 + 25h = 210$
 iii 6 hours
 2 a $h = \frac{A}{10}$ b 10 m c 17 m

Chapter 4

Warm-up quiz

- 1 a 5 cm b 13 m c 41 mm
 2 a 9 b 49 c 20 d 45
 3 a 0.4568 b 0.3457 c 0.0456 d 0.2800
 4 a 4.23 b 5.68 c 76.90 d 23.90
 5 a 5.92 b 15.36 c 4.86 d 8.09
 6 a $x = 64$ b $x = 28$ c $x = 108$
 d $x = 60$ e $x = 50$ f $x = 55$
 7 a $x = 2$ b $x = 3$ c $x = 12$ d $x = 6$
 e $x = 12$ f $x = 30$ g $x = 28$ h $x = 182$
 8 a $x = 0.6$ b $x = 0.6$ c $x = 2.1$ d $x = 0.5$
 9 a $x = 2$ b $x = 4$ c $x = 5$ d $x = 13$

4A

Now you try

Example 1

$x^2 + z^2 = y^2$ or $y^2 = x^2 + z^2$

Example 2

$10^2 + 24^2 = 26^2$

Exercise 4A

- 1 hypotenuse, triangle
 2 a c b x c u
 3 a False b True c True d False
 4 a $a^2 + b^2 = c^2$ b $d^2 + e^2 = f^2$
 c $x^2 + y^2 = z^2$ d $s^2 + t^2 = v^2$
 e $f^2 + g^2 = e^2$ f $a^2 + b^2 = x^2$
 5 a $3^2 + 4^2 = 5^2$ b $8^2 + 15^2 = 17^2$
 c $9^2 + 12^2 = 15^2$ d $5^2 + 12^2 = 13^2$
 e $9^2 + 40^2 = 41^2$ f $2.5^2 + 6^2 = 6.5^2$
 6 a $a^2 + b^2 = x^2$ b $a^2 + b^2 = d^2$
 c $d^2 + h^2 = x^2$

a	b	c	a ²	b ²	a ² + b ²	c ²
3	4	5	9	16	25	25
6	8	10	36	64	100	100
8	15	17	64	225	289	289

- a The last two columns
 b i 13 ii 20
 c i 25 ii 110
 8 a No
 b No, $a^2 + b^2 = c^2$ should be true for a right-angled triangle.
 9 a Yes b No c No d Yes
 e No f Yes
 10/11 $\{(3, 4, 5), (6, 8, 10), (9, 12, 15), (12, 16, 20), (15, 20, 25), (18, 24, 30), (21, 28, 35), (24, 32, 40), (27, 36, 45), (30, 40, 50), (33, 44, 55), (36, 48, 60), (39, 52, 65), (42, 56, 70), (45, 60, 75), (48, 64, 80), (51, 68, 85), (54, 72, 90), (57, 76, 95)\}, \{(5, 12, 13), (10, 24, 26), (15, 36, 39), (20, 48, 52), (25, 60, 65), (30, 72, 78), (35, 84, 91)\}, \{(7, 24, 25), (14, 48, 50), (21, 72, 75)\}, \{(8, 15, 17), (16, 30, 34), (24, 45, 51), (32, 60, 68), (40, 75, 85)\}, \{(9, 40, 41), (18, 80, 82)\}, \{(11, 60, 61)\}, \{(20, 21, 29), (40, 42, 58), (60, 63, 87)\}, \{(12, 35, 37), (24, 70, 74)\}, \{(28, 45, 53)\}, \{(33, 56, 65)\}, \{(16, 63, 65)\}, \{(48, 55, 73)\}, \{(13, 84, 85)\}, \{(36, 77, 85)\}, \{(39, 80, 89)\}, \{(65, 72, 97)\};$
- 50 Pythagorean triples

4B

Now you try

Example 3

$c = 5$

Example 4

6.61

Example 5

$\sqrt{53}$

Exercise 4B

- 1 a 17 b 50 c $\sqrt{8}$
 2 a $c^2 = 3^2 + 5^2$ b $c^2 = 2^2 + 7^2$
 3 a, f
 4 a $c = 6.7$ b $c = 6.3$ c $c = \sqrt{22}$ d $c = \sqrt{34}$
 5 a $c = 10$ b $c = 13$ c $c = 17$ d $c = 15$
 e $c = 25$ f $c = 41$ g $c = 50$ h $c = 30$
 i $c = 25$
 6 a 4.47 b 3.16 c 15.62 d 11.35
 e 7.07 f 0.15

- 7 a $\sqrt{5}$ b $\sqrt{58}$ c $\sqrt{34}$ d $\sqrt{37}$
 e $\sqrt{109}$ f $\sqrt{353}$
- 8 4.4 m
 9 495 m
 10 2.4 m
 11 a 8.61 m b 5.24 m c 13.21 cm
 d 0.19 m e 17.07 mm f 10.93 cm
 12 250 m
 13 42 units
 14 5.83 m
 15 a 77.78 cm b 1.39 m c Reduce by 7.5 cm

4C _____

Now you try

Example 6

$a = 7$

Example 7

$x = 6.08$

Example 8

$x = \sqrt{\frac{25}{2}}$ or $\frac{5}{\sqrt{2}}$

Exercise 4C

- 1 a subtract b 16 c 11
 2 a T b F c T d F
 3 a 4 b 24 c 8
 4 a 16 b 24 c 6 d 21
 e 60 f 27
 5 a 8.66 b 11.31 c 5.11 d 17.55
 e 7.19 f 0.74
 6 5.3 m
 7 14.2 m
 8 49 cm
 9 1.86 m
 10 a $\sqrt{2}$ b $\sqrt{8}$ c $\sqrt{\frac{1}{2}}$
 11 a $\sqrt{187}$ b $\sqrt{567}$ c 40

4D _____

Now you try

Example 9

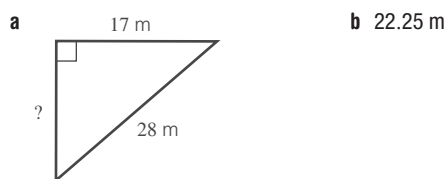

Example 10

The cable is 32.02 m long

Exercise 4D

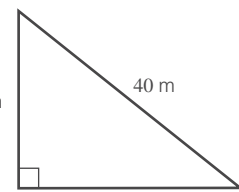
- 1 B
 2 a B, III b C, I c A, II
 3 a  b 31.22 m

- 4 7.07 cm
 5 a 6.4 m b 5.7 cm c 6.3 m d 6.0 m
 6 3.0 m
 7 142.9 m
 8 3823 mm
 9 1060 m
 10 466.18 m
 11 a 27 m b 118.3 m

4E _____

Now you try

Example 11

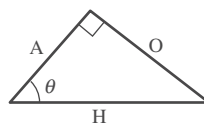

Example 12

a $\cos \theta = \frac{7}{9}$ b $\sin \theta = \frac{6}{7}$ c $\tan \theta = \frac{8}{5}$

Exercise 4E

- 1 a 13 m b 5 m c 12 m
 2 a hypotenuse b opposite c adjacent d opposite
 e hypotenuse f adjacent
 3 a

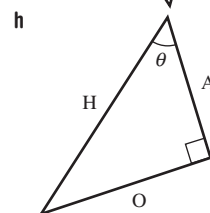
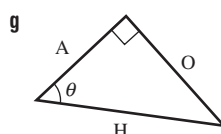
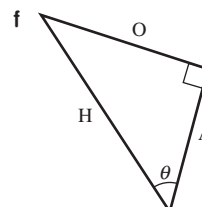
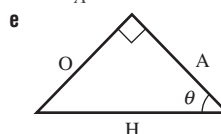
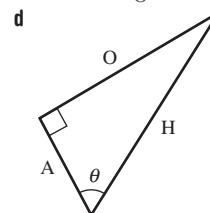
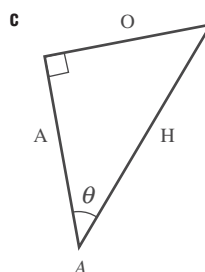
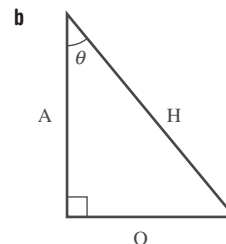
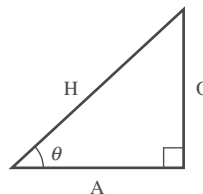

4 a $\sin \theta = \frac{4}{7}$ b $\tan \theta = \frac{5}{4}$ c $\cos \theta = \frac{3}{5}$
 d $\sin \theta = \frac{2}{3}$ e $\tan \theta = 1$ f $\cos \theta = \frac{2}{3}$
 g $\tan \theta = \frac{11}{12}$ h $\cos \theta = \frac{1}{2}$ i $\tan \theta = \frac{5}{3}$

5 a $\sin \theta = \frac{3}{5}$ $\cos \theta = \frac{4}{5}$ $\tan \theta = \frac{3}{4}$
 b $\sin \theta = \frac{12}{13}$ $\cos \theta = \frac{5}{13}$ $\tan \theta = \frac{12}{5}$
 c $\sin \theta = \frac{12}{13}$ $\cos \theta = \frac{5}{13}$ $\tan \theta = \frac{12}{5}$

6 a i $\frac{5}{13}$ ii $\frac{5}{13}$ iii The same
 b i $\frac{12}{13}$ ii $\frac{12}{13}$ iii The same
 c i $\frac{5}{12}$ ii $\frac{5}{12}$ iii The same

7 a $\frac{3}{5}$ b $\frac{4}{5}$ c $\frac{3}{4}$
 8 $\frac{3}{4}$
 9 a 5 b 4 c 3 d 3 e 4
 10 a $\frac{4}{5}$ b $\frac{3}{5}$ c $\frac{3}{5}$ d $\frac{3}{4}$ e $\frac{4}{5}$ f $\frac{4}{3}$

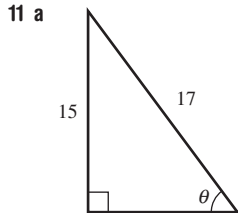

c $\sin \theta = \frac{15}{17}$, $\cos \theta = \frac{8}{17}$, $\tan \theta = \frac{15}{8}$
 12 a i $\frac{1}{2}$ ii $\frac{\sqrt{3}}{2}$ iii $\frac{1}{\sqrt{3}}$ iv $\frac{\sqrt{3}}{2}$
 v $\frac{1}{2}$ vi $\sqrt{3}$
 b i They are equal. ii They are equal.
 13 b i 0.766 ii 0.643 iii 0.839 iv 0.766
 v 1.192 vi 0.643
 c $\sin 40^\circ = \cos 50^\circ$, $\sin 50^\circ = \cos 40^\circ$, $\tan 50^\circ = \frac{1}{\tan 40^\circ}$
 $\tan 40^\circ = \frac{1}{\tan 50^\circ}$

4F

Now you try

Example 13

a 0.34 b 0.79 c 2.36

Example 14

3.83

Example 15

a 1.69 b 5.03 c 8.48

Exercise 4F

1 a A b 0 c H
 2 a sin b tan c cos
 3 B
 4 a 0.34 b 0.80 c 2.05 d 0.73
 e 0.10 f 0.25 g 0.46 h 0.24

5 a 3.06 b 18.94 c 5.03
 d 0.91 e 1.71 f 9.00
 g 2.36 h 4.79 i 7.60
 6 a 5.95 b 0.39 c 13.38 d 3.83
 e 8.40 f 1.36 g 29.00 h 1.62
 i 40.10 j 4.23 k 14.72 l 13.42
 m 17.62 n 5.48
 7 10.39 m
 8 1.12 m
 9 44.99 m
 10 10.11 m
 11 a 65° b 2.113 c 2.113
 12 a 20.95 m b 10 cm

Progress quiz

1 a $x^2 + y^2 = z^2$ b $r^2 + s^2 = t^2$
 c $5^2 + 12^2 = 13^2$
 2 a 15 b $\sqrt{73}$ c 7.2
 3 a $a = 10$ b $b = 6.32$
 4 2.2 m
 5 3.46 m
 6 3.3 m
 7 a $\sin \theta = \frac{4}{7}$ b $\tan \theta = \frac{5}{9}$ c $\cos \theta = \frac{6}{11}$
 8 a 8.19 b 5.96
 9 2.6 m

4G

Now you try

Example 16

$x = 3.58$

Example 17

$x = 5.85$

Example 18

$x = 4.45$, $y = 10.95$

Exercise 4G

1 a $\cos \theta = \frac{7}{x}$ b $\sin \theta = \frac{10}{x}$ c $\tan \theta = \frac{2.3}{x}$
 2 C
 3 a $\cos 25^\circ$ b $\tan 65^\circ$ c $\frac{6}{\sin 72^\circ}$
 4 a 4.10 b 6.81 c 37.88
 d 0.98 e 12.80 f 14.43
 g 9.52 h 114.83 i 22.05
 5 a 13.45 b 16.50 c 57.90 d 26.33
 e 15.53 f 38.12 g 9.15 h 32.56
 i 21.75 j 49.81 k 47.02 l 28.70
 6 40 m
 7 3848 m
 8 a $x = 7.5$, $y = 6.4$ b $a = 7.5$, $b = 10.3$
 c $a = 6.7$, $b = 7.8$ d $x = 9.5$, $y = 12.4$
 e $x = 12.4$, $y = 9.2$ f $x = 21.1$, $y = 18.8$
 9 a 27 m b 104 m
 10 a B as student B did not use an approximation in their working out.
 b Use your calculator and do not round $\sin 31^\circ$ during working.
 11 a 23.7 m b 124.9 m

4H

Now you try

Example 19

28°

Example 20

48.19°

Example 21

25°

Exercise 4H

- 1 a $\sin \theta = \frac{8}{9}$ b $\sin \theta = \frac{5}{7}$
 c $\cos \theta = \frac{14}{23}$ d $\tan \theta = \frac{15}{26}$
- 2 a 11.54 b 64.53 c 68.20
 3 a $\frac{1}{2}$ b 0.6 c $\tan^{-1}\left(\frac{5}{4}\right)$
- 4 a 30° b 60° c 45° d 30°
 e 45° f 30° g 90° h 50°
 i 90° j 55° k 0° l 70°
- 5 a 34.85° b 19.47° c 64.16°
 d 75.52° e 36.87° f 38.94°
 g 30.96° h 57.99° i 85.24°
- 6 a 43° b 31° c 41° d 16° e 55°
 f 50° g 49° h 41° i 34°
- 7 17°
 8 23.13°
 9 a $\frac{1}{2}$ b 50° c $45^\circ = \tan^{-1}(1)$
 d 0.707
 10 25.4°
 11 26.6°
 12 45°
 13 a 18° b 27° c 45°
 d 5.67 m e up to 90°

4l _____

Now you try

Example 22

29 m

Example 23

16°

Exercise 4I

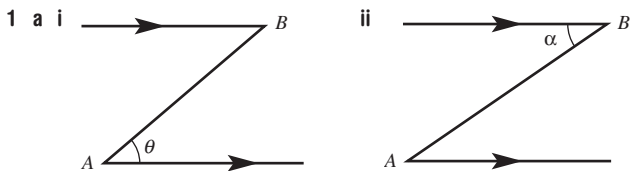

- b Yes, $\theta = \alpha$, alternate angles are equal on parallel lines.
 2 C
 3 a 22° b 22°
 4 $a = 65, b = 25$
 5 16 m
 6 157 m
 7 38 m
 8 90 m
 9 37°
 10 6°
 11 10°
 12 a 6° b 210 m
 13 4634 mm
 14 Yes, by 244.8 m
 15 a i 47.5 km ii 16.25 km
 b No
 c Yes

Maths@Work: Carpenter

- 1 a 450 mm b 2400 mm c 9010 mm
 d 2700 mm e 46 000 mm



3 Diagrams are not to scale.

a 770 mm by 1040 mm

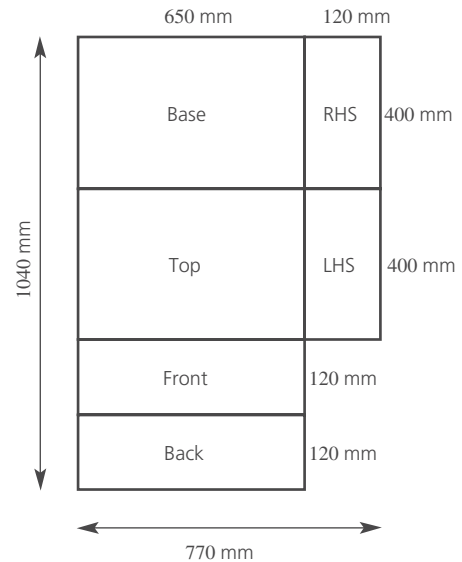

b 2430 mm by 1540 mm

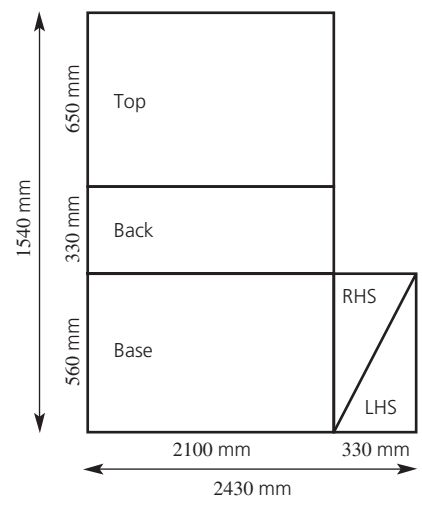

- 4 a $BC = 72$ mm b $BC = 106$ mm
 c $AB = 187$ mm d $AB = 364$ mm
 5 1370 tiles
 6 170 m^2

Location	Volume of rain in litres
Strahan, TAS	232 713
Melbourne, VIC	94 860
Port Lincoln, SA	77 724
Perth, WA	111 384
Newcastle, NSW	183 600
Tully, QLD	628 065
Alice Springs, NT	37 179

Puzzles and games

- 1 44
 2 a a^2, b^2, c^2 b $a^2 + b^2 = c^2$
 c Answer will vary
 3 a A diagonal of the square b $\sqrt{2}$ cm c 63.7%
 4 Round peg square hole
 5 171 cm

Short-answer questions

- 1 a $x^2 + y^2 = z^2$ b $s^2 + t^2 = u^2$ c $e^2 + f^2 = d^2$
 2 a 10 b 25 c 13 d 37
 e 7.21 f 7.07
 3 a 3.32 b 7.55 c 9.95
 4 4.49 m
 5 a 13 cm b 13.93 cm
 6 19 m
 7 a 0.64 b 2.25 c 0.72
 8 a $\sin \theta$ b $\tan \theta$ c $\cos \theta$
 9 a 11.33 b 4.88 c 48.02 d 10.31
 e 50.71° f 60°
 10 28.01 m
 11 25 m
 12 177.91 m
 13 63.2 m

Multiple-choice questions

- 1 A 2 B 3 A 4 C 5 B 6 C
 7 D 8 C 9 A 10 B

Extended-response questions

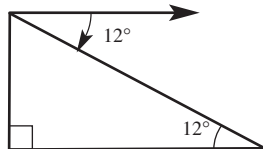
- 1 a 
 b 470 m c 3° d 1530 m
 2 a 2.15 m b 0.95 m c 3.05 m

Chapter 5

Warm-up quiz

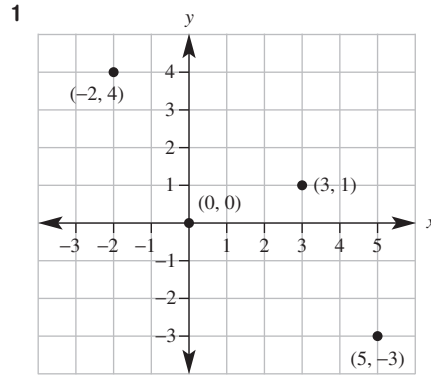

- 2 a 1 b -1 c -3 d -4
 3 a $x = 5$ b $x = -2$ c $x = -3$ d $x = 4$
 e $x = -2$ f $x = 4$
 4 a 3 b -4 c 4 d -3

5

x	-2	-1	0	1	2
a y	1	2	3	4	5
b y	-5	-3	-1	1	3

- 6 a False b True c True d False
 7 a 7 b 6.5 c 3 d -5
 8 a 5 b 4 c 5 d 3
 9 a 4 b 5 c 7 d 3

5A

Now you try

Example 1

a

x	-2	-1	0	1	2
y	-8	-5	-2	1	4

b

x	-2	-1	0	1	2
y	8	6	4	2	0

Example 2

a

x	-3	-2	-1	0	1	2	3
y	-5	-4	-3	-2	-1	0	1

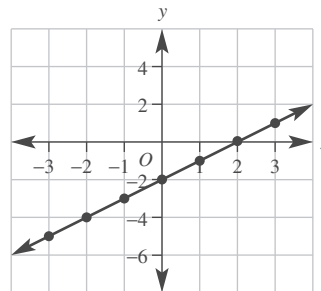

b

x	-3	-2	-1	0	1	2	3
y	13	10	7	4	1	-2	-5

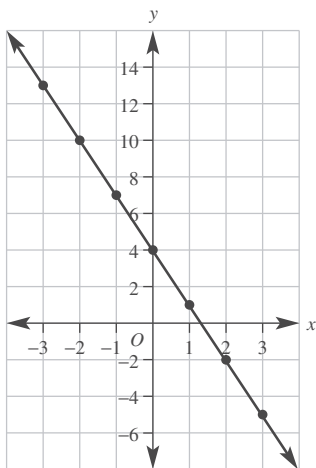

Example 3

- a Yes b No

Exercise 5A

1 a

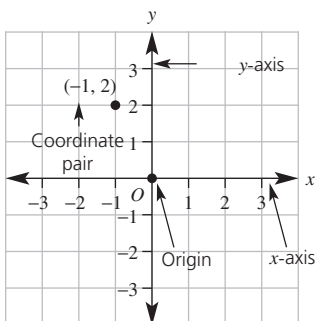

- b i x-coordinate ii y-coordinate
iii right, down

2 a

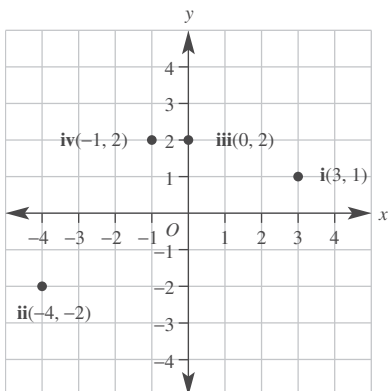

- b A(4, 1), B(2, 0), C(0, -3), D(-2, 2), E(-2, -4), F(3, -4)

3 C

4 A, C

5 a

x	-2	-1	0	1	2	3
y	0	1	2	3	4	5

b

x	-2	-1	0	1	2
y	-1	1	3	5	7

c

x	-2	-1	0	1	2
y	4	2	0	-2	-4

d

x	-2	-1	0	1	2	3
y	5	2	-1	-4	-7	-10

6 a

x	-3	-2	-1	0	1	2	3
y	-4	-3	-2	-1	0	1	2

b

x	-3	-2	-1	0	1	2	3
y	0	1	2	3	4	5	6

c

x	-3	-2	-1	0	1	2	3
y	-9	-7	-5	-3	-1	1	3

- a $y = x - 1$ b $y = x + 3$ c $y = 2x - 3$

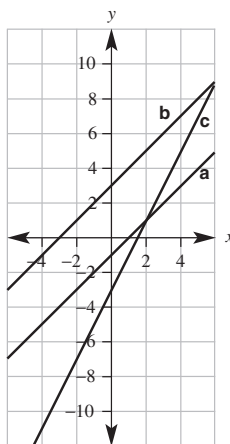

d

x	-3	-2	-1	0	1	2	3
y	9	6	3	0	-3	-6	-9

e

x	-3	-2	-1	0	1	2	3
y	5	3	1	-1	-3	-5	-7

f

x	-3	-2	-1	0	1	2	3
y	7	6	5	4	3	2	1

- d $y = -3x$ e $y = -2x - 1$ f $y = -x + 4$

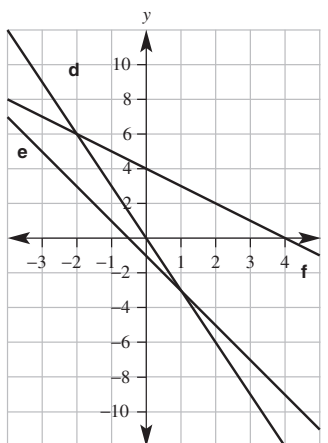

7 a No

b Yes

c No

8 a Yes

b Yes

c No

9 a $y = x + 2$

b $y = 2x$

c $y = 2x + 1$

d $y = 3x - 1$

e $y = x - 2$

10 $y = 3x$

11 a iv

b iii

c i

d ii

12 a $y = 2x + 7$

b $y = 20 - x$

c $y = 2x - 1$

d $y = \frac{1}{2}x + 1$

- e $y = -3x + 4$ f $y = 5x + 4$

5B

Now you try

Example 4

a x-intercept is -1, y-intercept is 2

b x-intercept is 3, y-intercept is 2

Example 5

a 5 b 3

Example 6

a 2 b -3

Exercise 5B

- 1 a x -axis b x -coordinate c x -intercept
 2 a A(1, 0), D(-2, 0), H(3, 0) b B(0, 3), E(0, -1)
 3 a $y = 0$ b $x = 0$
 4 a 1, 1 b -2, 2 c 4, 8 d -5, 10
 e 2, 3 f 7, -3 g -11, 5 h -2, -5
 5 a 5 b 1 c -7 d -3 e 2
 f -4 g -2 h 10 i 11 j 3
 k 2 l 6 m -3 n -1 o -3
 p 3
 6 a -6 b 4 c 4 d -2 e -4
 f 3 g 7 h 2 i 4 j 6
 k 1 l -3
 7 a $\frac{1}{2}, -1$ b 4, -2 c 12, 4 d $2\frac{1}{3}, 3\frac{1}{2}$
 8 a 100 m b 20 s
 9 a 20 minutes b 80 litres
 10 When you substitute $x = 0$ into the rule, $y = 3 \times (0) = 0$. It means the graph passes through the origin.
 11 a $A = -60$ b She makes a loss of \$60.
 c 30 badges
 d She then starts to make a profit from her stall.
 e

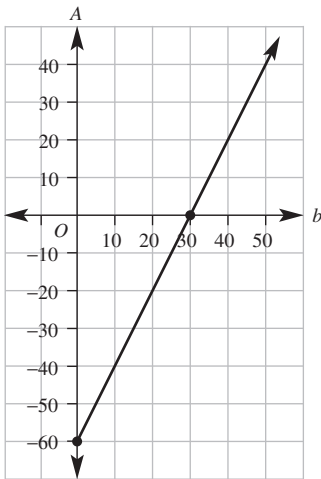

5C

Now you try

Example 7

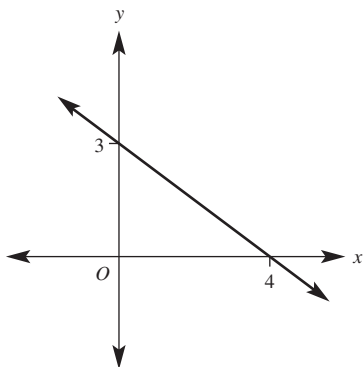

Example 8

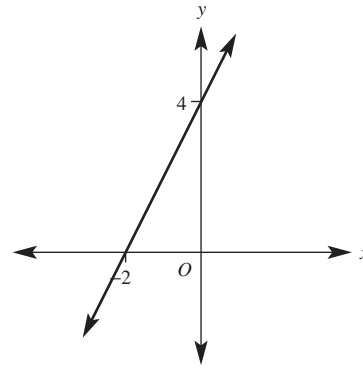

Exercise 5C

- 1 a 2 b 0 c 0
 2 a 3 b -4
 3 a -2 b 2
 4 a

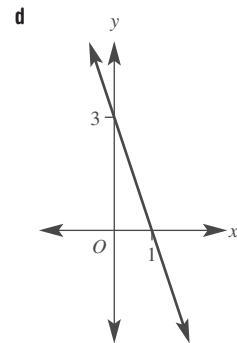
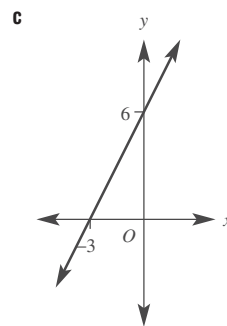
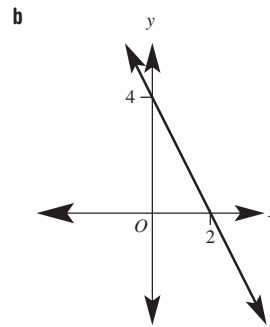
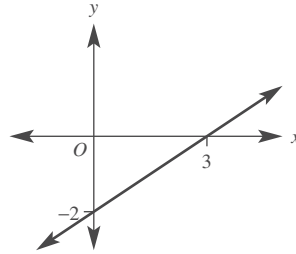

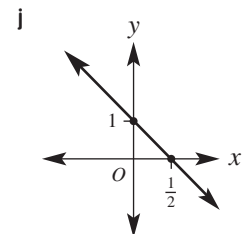
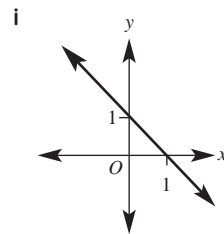
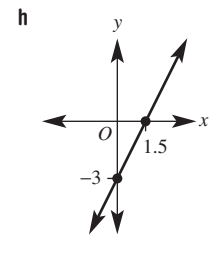
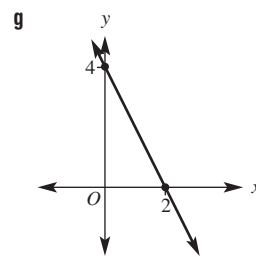
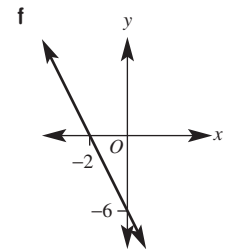
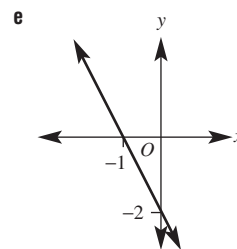
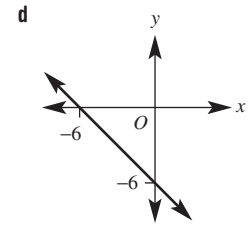
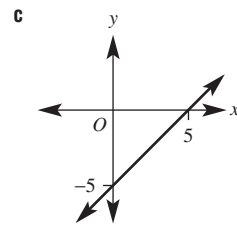
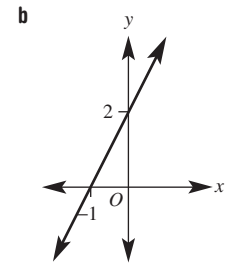
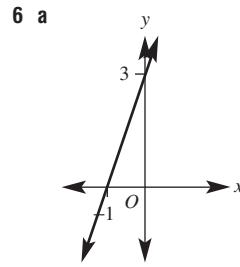
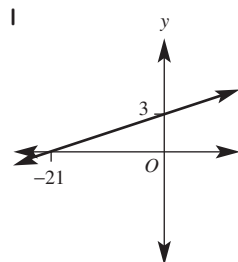
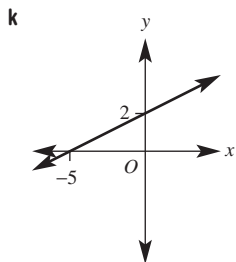
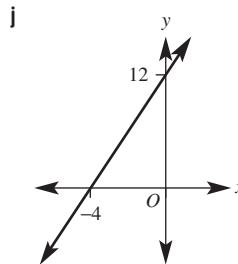
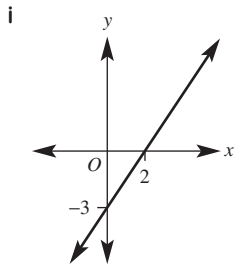
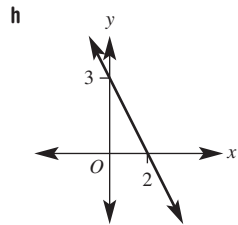
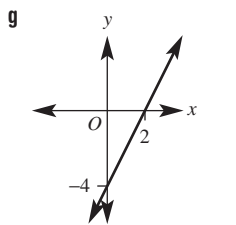
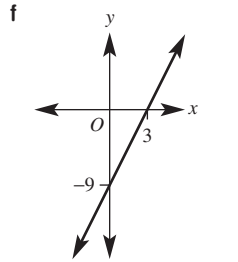
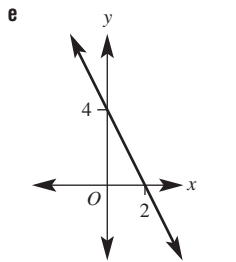
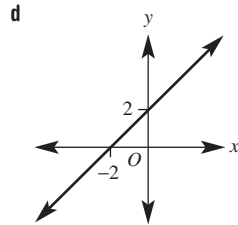
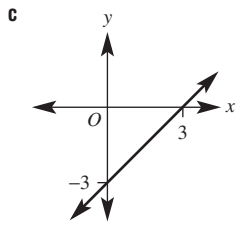
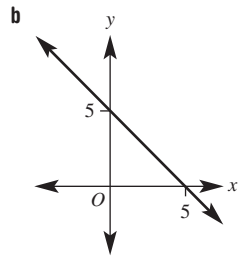
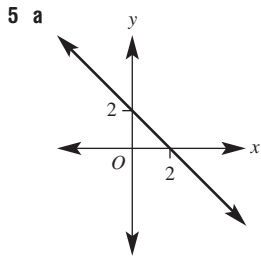

7 a 8 m
b 4 seconds

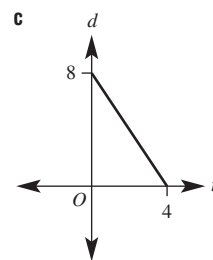

8 a

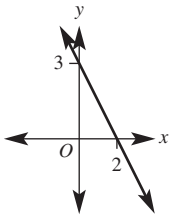

b

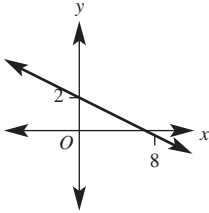

c

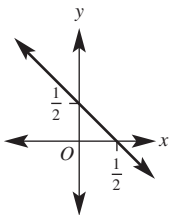

9 a For 0.5 across, graph moves 1 down.

b For 1.5 across, graph moves one up.

10 a $x + y = 4$

b $x + y = 2$

c $x - y = 3$

d $x - y = -1$

5D

Now you try

Example 9

a

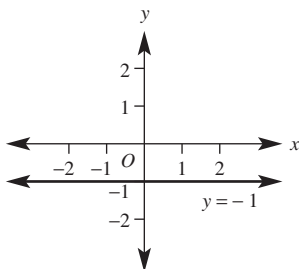

b

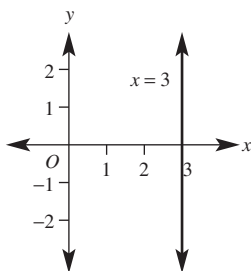

c

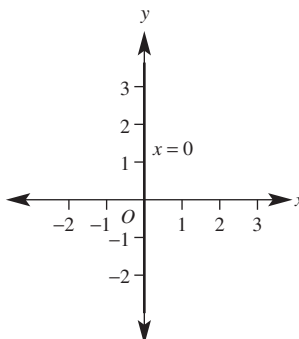

Example 10

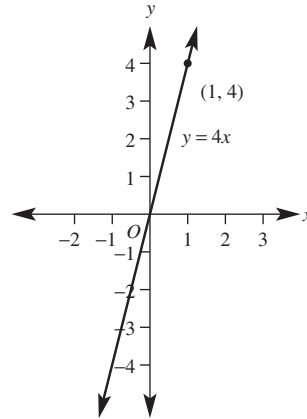

Example 11

a $x = 1$

b $y = 2$

Exercise 5D

1 a Horizontal

b Horizontal

c Vertical

d Horizontal

e Vertical

f Vertical

2 a ii, iv

b i, iii

3 a i 2

ii -3

b i 3

ii -2

4 b, e, f

5 a

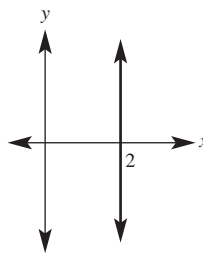

b

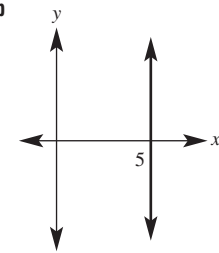

c

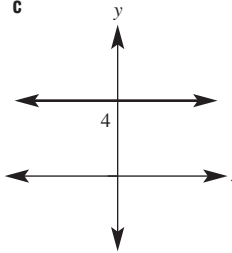

d

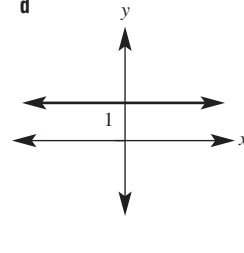

e

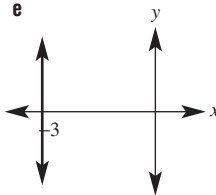

f

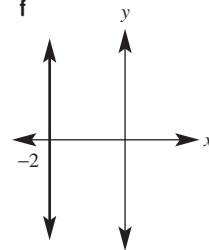

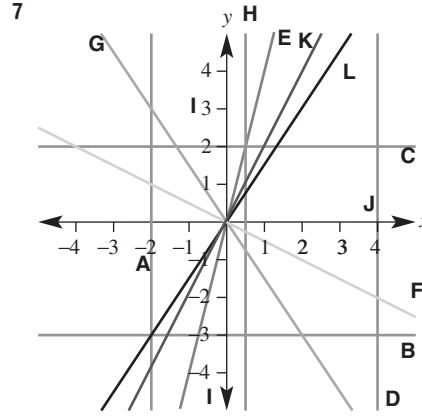
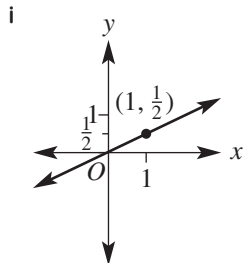
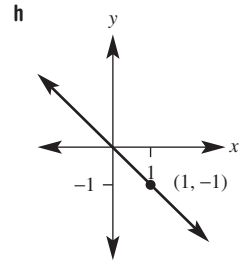
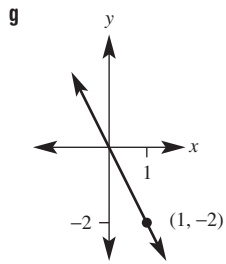
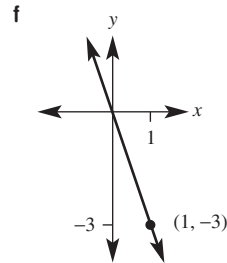
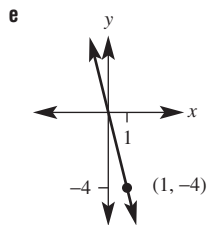
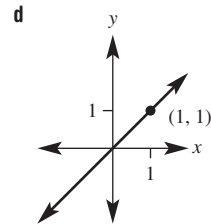
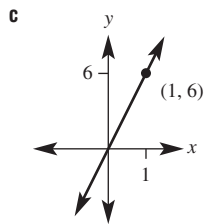
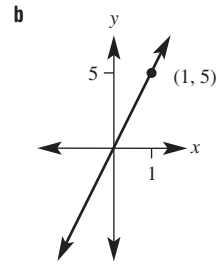
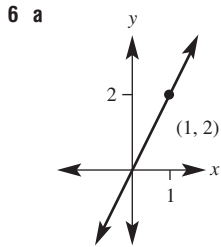
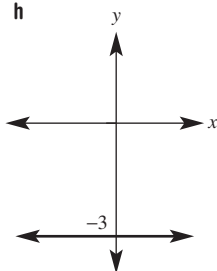
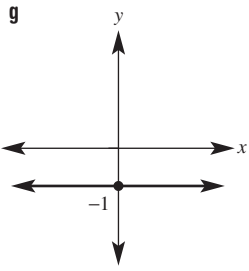

- 8 a** $y = -2$ **b** $y = 4$ **c** $x = -2$ **d** $x = 5$
e $y = 1.5$ **f** $x = -6.7$
- 9 a** $y = 3$ **b** $x = 5$ **c** $x = -2$ **d** $y = 0$
- 10 a** $y = 250$ **b** $y = -45$
- 11 a** $y = 2x$ **b** $y = 3x$ **c** $y = -x$
d $y = -3x$
- 12 a** $A = 15$ square units **b** $A = 68$ square units
- 13 a** **i** $y = 1$ or $y = -5$ **ii** $y = 0$ or $y = -4$
iii $y = 3\frac{1}{2}$ or $y = -7\frac{1}{2}$
b **i** $y = 1$ or $y = -5$ **ii** $y = 7$ or $y = -11$
iii $y = 9\frac{1}{2}$ or $y = -13\frac{1}{2}$

5E

Now you try

Example 12

- a** Zero **b** Positive, 2 **c** Undefined
d Negative, $-\frac{2}{5}$

Example 13

- a** $m = 2$ **b** $m = -\frac{8}{5}$

Exercise 5E

- 1 a** **i** 2 **ii** 4
b **i** 2 **ii** 1
c **i** 1 **ii** 3
d **i** 3 **ii** -3
e **i** 1 **ii** -3
f **i** 4 **ii** -1
- 2 a** Zero **b** Negative
c Positive **d** Undefined
- 3 a** Positive, 1 **b** Positive, 2 **c** Zero
d Zero **e** Negative, $-\frac{2}{3}$ **f** Negative $-\frac{3}{4}$
- g** Undefined **h** Undefined **i** Positive, $\frac{1}{2}$
j Positive, 3 **k** Positive, 2 **l** Negative, -4
- 4 A** 1 **B** -2 **C** 1 **D** $\frac{1}{2}$
E -2 **F** 3
- 5 a** 2 **b** -1 **c** -2 **d** 1
e 2 **f** -2 **g** -1 **h** $\frac{1}{2}$
i $\frac{3}{2}$ **j** $-\frac{5}{2}$ **k** $\frac{1}{3}$ **l** $\frac{5}{2}$
- 6 a** $-\frac{1}{20}$ **b** 17.5 or $\frac{35}{2}$ **c** $-\frac{1}{5}$ **d** 7.5 or $\frac{15}{2}$
- 7** 40 metres
8 90 metres

- 9 a 6 b 1 c 0 d -4
 10 a i -1 ii -3
 b (4.5, 0)
 c i (6, 0) ii (1.5, 0) iii (2.4, 0)

5F

Now you try

Example 14

$V = 2t$

Example 15

- a 50 L/min
 b

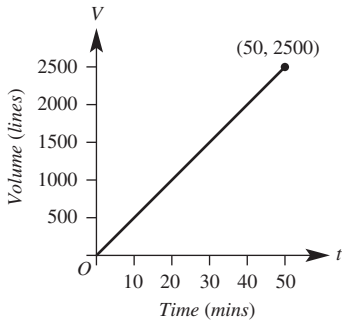

- c i 50 ii $V = 50t$
 d i 1000 L ii 40 mins

Exercise 5F

- 1 a No b Yes c Yes d No
 2 a 60 km/h b 9 m/s c 5 L/min
 d \$1.50/L e \$30/h f 3°C/min
 3 a i 10 km ii 20 km iii 30 km
 b 10 km/h
 c 10
 d They are the same.
 4 a $d = 60t$ b $g = 2t$ c $C = 1.5n$
 d $P = 20t$
 5 a 100 L/h

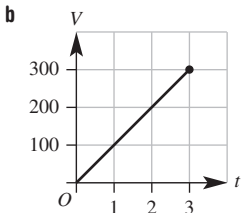

- c i 100 ii $V = 100t$
 d i 150 L ii 2 h

- 6 a 25 km/h

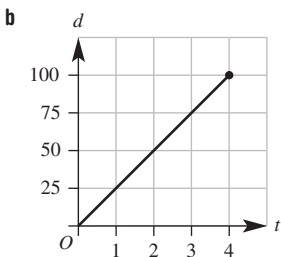

- c i 25 ii $d = 25t$
 d i 62.5 km ii 1.6 h
 7 a 100 km/h b 7 cm/s c 2.5 cm/min
 d 49 mm/min
 8 Sally
 9 The panther
 10 a 10.2 L b 72.25 L c 800 km

- 11 a $A = 12w$

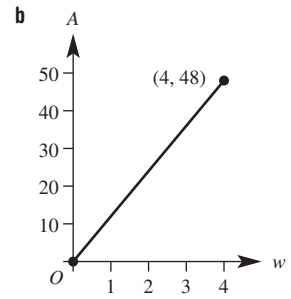

- c Yes, the rule for the graph is in the form $y = mx$.
 12 a $\frac{1}{2}$ b $\frac{1}{4}$ c $\frac{3}{4}$
 d 1 min 20 s or $1\frac{1}{3}$ min
 13 1.2 h or 1 h 12 min

5G

Now you try

Example 16

- a Gradient = 3, y -intercept = -2
 b Gradient = -1, y -intercept = 0

Example 17

- a $y = -3x + 5$ b $y = -2x + 3$

Example 18

- a Gradient = 3, y -intercept = -2

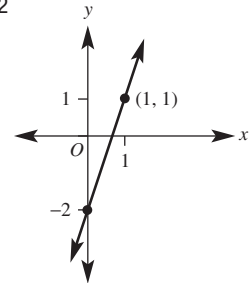

- b Gradient = $-\frac{5}{4}$, y -intercept = 1

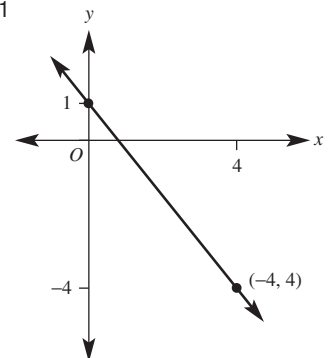

Example 19

$y = -\frac{2}{3}x + 4$

Gradient = $-\frac{2}{3} = \frac{-2}{3}$

y -intercept = 4

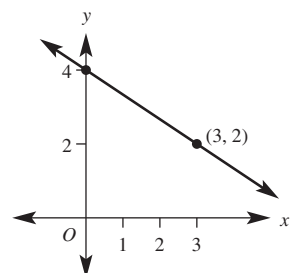

Exercise 5G

- 1 a gradient b y-intercept c subject
 2 a iii b i c ii d iv
 3 a i (2, 6) ii (3, 1)
 b i (1, 1) ii (3, -5)
 4 a 3, 5 b 1, 4 c 2, -1
 5 a Gradient = 3, y-intercept = -4
 b Gradient = -5, y-intercept = -2
 c Gradient = -2, y-intercept = 3
 d Gradient = $\frac{1}{3}$, y-intercept = 4
 e Gradient = -4, y-intercept = 0
 f Gradient = 2, y-intercept = 0
 g Gradient = 2.3, y-intercept = 0
 h Gradient = -0.7, y-intercept = 0
 i Gradient = 1, y-intercept = 0
 6 a $y = -3x + 4$ b $y = -2x + 7$
 c $y = 3x + 2$ d $y = 2x + 7$
 e $y = 5x - 3$ f $y = -2x + 4$
 g $y = -\frac{3}{2}x + 3$ h $y = 2x - \frac{5}{2}$
 i $y = \frac{5}{3}x + 2$

7 a $m = 1, y\text{-int} = -2$

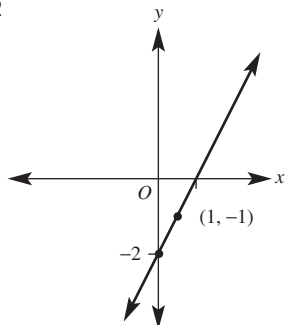

b $m = 2, y\text{-int} = 1$

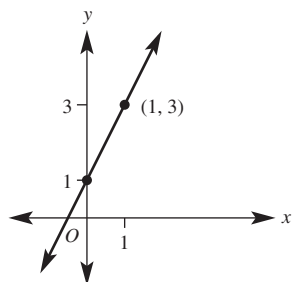

c $m = 3, y\text{-int} = 2$

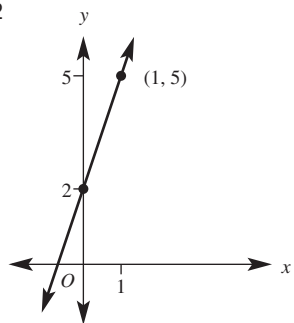

d $m = \frac{1}{2}, y\text{-int} = 2$

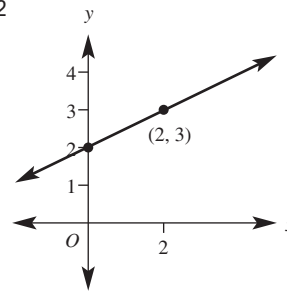

e $m = -3, y\text{-int} = 3$

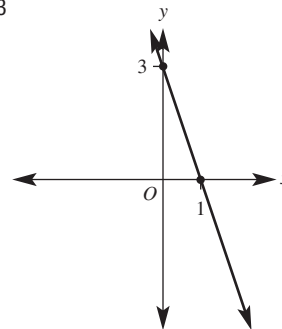

f $m = \frac{3}{2}, y\text{-int} = 1$

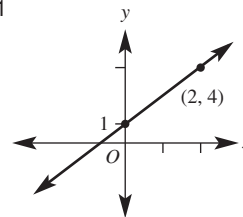

g $m = 2, y\text{-int} = 0$

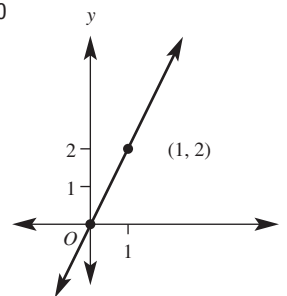

h $m = -\frac{4}{3}, y\text{-int} = 0$

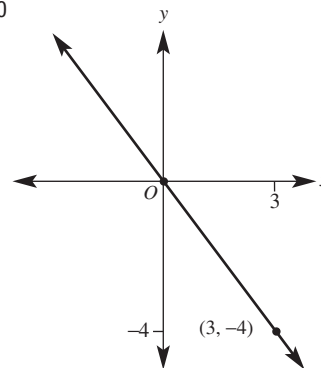

i $m = \frac{-2}{3}, y\text{-int} = 0$

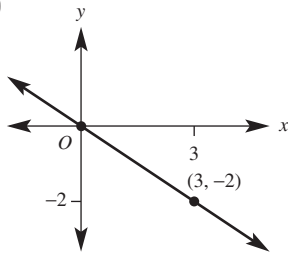

8 a $m = -1, y\text{-int} = 4$

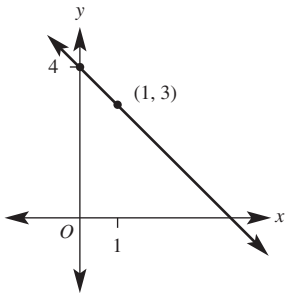

b $m = 1, y\text{-int} = 6$

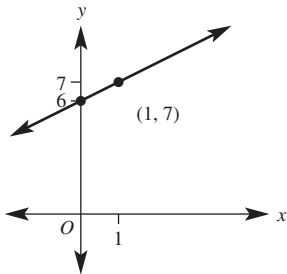

c $m = -2, y\text{-int} = 3$

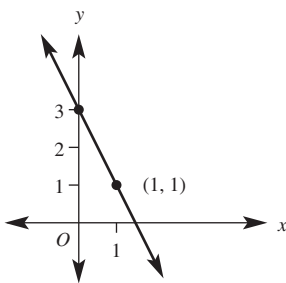

d $m = \frac{-1}{2}, y\text{-int} = 4$

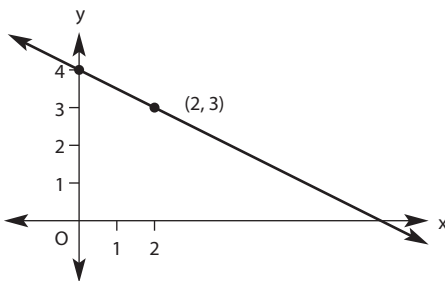

e $m = \frac{-2}{3}, y\text{-int} = 2$

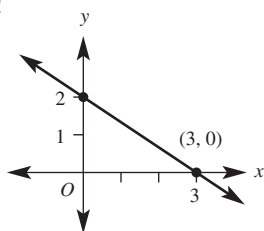

f $m = \frac{-4}{3}, y\text{-int} = 4$

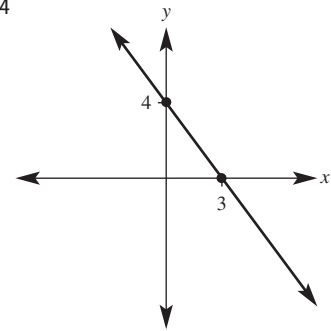

g $m = \frac{1}{2}, y\text{-int} = -2$

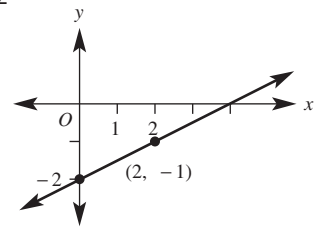

h $m = \frac{2}{3}, y\text{-int} = -2$

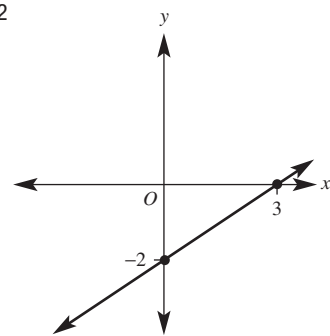

i $m = \frac{3}{4}, y\text{-int} = -3$

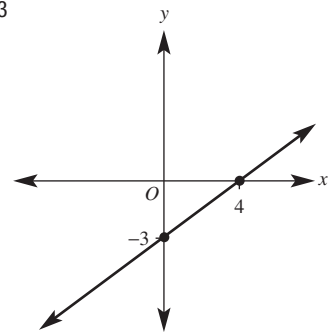

j $m = \frac{-1}{4}, y\text{-int} = 0$

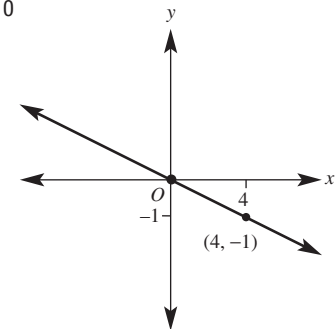

k $m = \frac{1}{5}$, $y\text{-int} = 0$

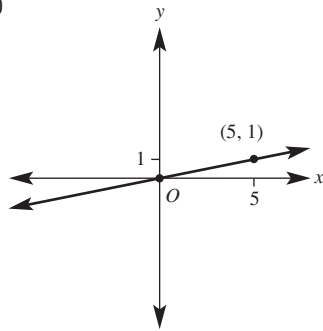

l $m = 4$, $y\text{-int} = 0$

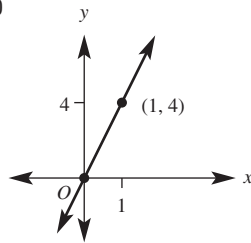

9 a Gradient = 4, $V\text{-intercept} = 2$

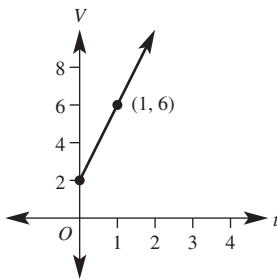

b Gradient is the rate the water level is increasing (the rate of rain fall in mL/h); the $V\text{-intercept}$ is the amount of water in the gauge before the storm.

10 Yes, she loses the bet. 6 needs to be divided by 2 also to give $2x + 3$.

11 c, d, f

12 a $y = 2x + 2$, $y\text{-intercept}$ is 2

b Expand brackets

13 a $y = 2x + 3$

b $y = -x + 2$

c $y = 2x + 3$

d $y = \frac{1}{2}x + 3$

e $y = \frac{1}{2}x + 3\frac{1}{2}$

Progress quiz

1 a i

x	-3	-2	-1	0	1	2	3
y	-7	-4	-1	2	5	8	11

ii

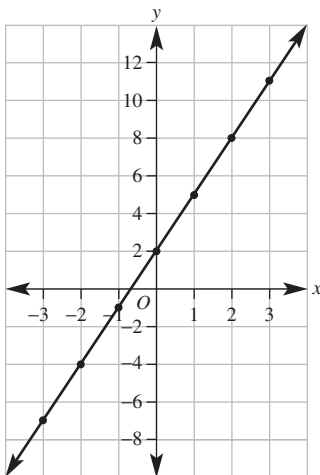

b i

x	-3	-2	-1	0	1	2	3
y	10	8	6	4	2	0	-2

ii

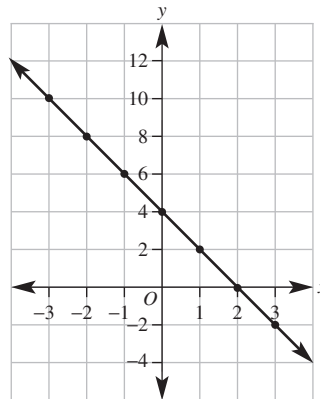

2 a No

b Yes

3 a (1, 0) and (0, -2)

b (3, 0) and (0, -5)

4 a i $y\text{-int} = 6$

ii $x\text{-int} = -2$

iii

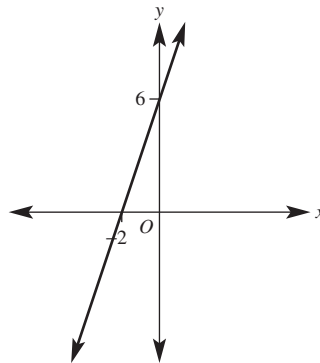

b i $y\text{-int} = -8$

ii $x\text{-int} = -4$

iii

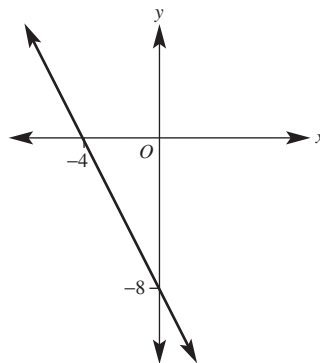

c i $y\text{-int} = -2$

ii $x\text{-int} = 5$

iii

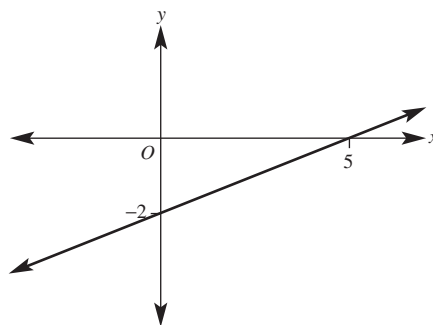

5 a 10 km b 20 min

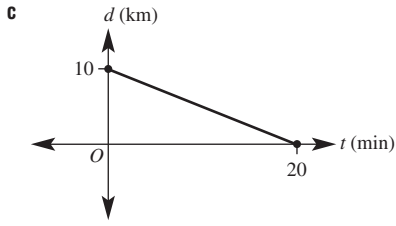

6 a

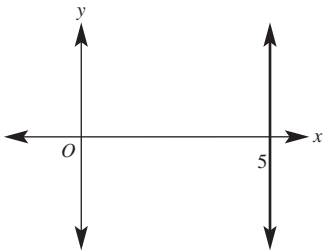

b

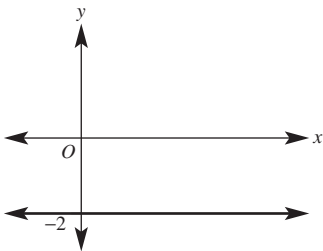

c

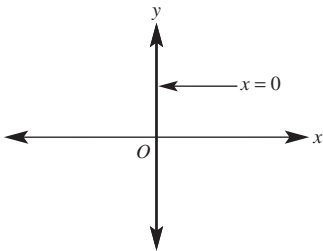

7

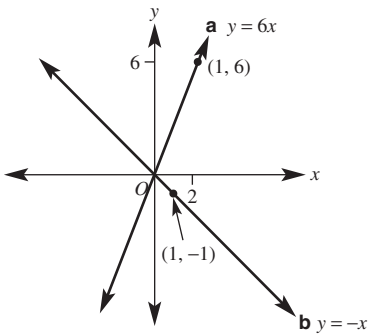

8 a $m = 1$

b $m = 0$

c $m = \frac{-3}{2}$

d Undefined

e i $m = 2$

ii $m = \frac{7}{3}$

iii $m = -5$

iv $m = 0$

9 a $d = 50t$

b $E = 16t$

c $r = 80$

10 a 60 L/min

b

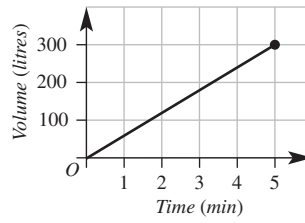

c i 60

ii $V = 60t$

d i 120 L

ii 3.5 min

11 a Gradient = 2, y -intercept = -3

b Gradient = -4, y -intercept = 1

c Gradient = $\frac{1}{2}$, y -intercept = 0

d Gradient = 2, y -intercept = 3

e Gradient = 2, y -intercept = 4

12 a Gradient = 3, y -intercept = -2

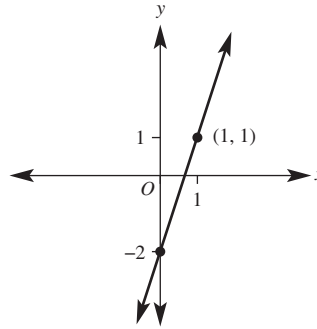

b Gradient = $-\frac{1}{2}$, y -intercept = 3

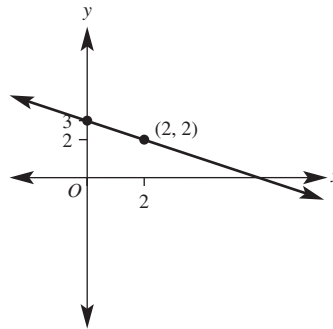

c Gradient = $-\frac{3}{2}$, y -intercept = 4

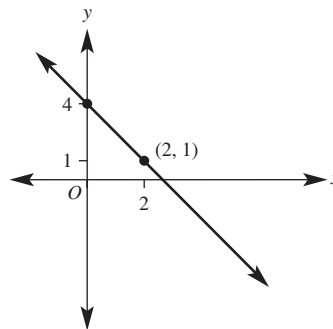

5H

Now you try

Example 20

$y = 2x + 6$

Example 21

$y = 2x - 5$

Exercise 5H

1 gradient, y -intercept, point

- 2 a $y = 2x + 5$ b $y = 4x - 1$
 c $y = -2x + 5$ d $y = -x - \frac{1}{2}$

3 C

- 4 a 1 b 3 c 5
 5 a $y = 2x + 6$ b $y = x + 2$
 c $y = -4x - 4$ d $y = 2x - 2$
 e $y = 8x + 8$ f $y = -x + 4$
 g $y = -2x + 6$
 6 a $y = \frac{3}{4}x + 3$ b $y = -\frac{3}{4}x + 3$
 c $y = -\frac{5}{4}x + 3$ d $y = \frac{3}{2}x + 4$
 e $y = \frac{3}{5}x$ f $y = -\frac{1}{3}x - 1$
 7 a $y = 3x + 5$ b $y = -2x - 1$
 c $y = -3x + 8$ d $y = x - 3$
 e $y = -3x + 3$ f $y = 5x - 1$
 g $y = -x + 8$ h $y = -3x + 6$
 i $y = -2x + 2$ j $y = -4x - 9$

8 $y = 5x + 1$

9 (2.5, 0)

10 a $y = 35x + 80$ b After 12 weeks

- 11 a i 2 ii $y = 2x + 2$
 b i -4 ii $y = -4x + 11$
 c i -1 ii $y = -x + 3$
 d i 1 ii $y = x - 4$

12 a $y = -20x + 120$ b 120 L

13 a $y = 2x - 3$

b (1.5, 0), (0, -3)

c The x -intercept is when the temperature reaches 0°C and the y -intercept represents the temperature at midnight.

5I

Now you try

Example 22

- a (4, 5) b (-2, 2.5)

Example 23

6.71

Exercise 5I

- 1 a 8 b 1 c -3 d 5.5
 2 a 5 b 10 c 5.1 d 6.7
 3 a i 3 ii 4
 b i 2 ii 7
 4 a (3, 3) b (2, 2) c (1, 5)
 d (4, 1) e (-1, 3) f (-1, -1)
 g (1.5, 1.5) h (2.5, 2) i (0.5, 3)
 j (-1.5, -2.5) k (-3, -8.5) l (0.5, -2.5)
 5 a 5.10 b 2.83 c 5.39 d 4.47
 e 3.61 f 2.83 g 8.94 h 7.21
 i 6.71

6 (-1, 5.5) and (5, 0.5)

7 B(8, 0), A(-6, 5), A(-6, 9)

8 a (-3, 1) b (1, -4) c (8, 3)

9 a 12.8 b 24.2

10 a (3, 5), (3, -1), (0, 2), (6, 2) are the obvious points

b A circle

11 a $\frac{1}{3}$

b $\frac{1}{3}$

c i (1, 1) ii (-2, -0.5) iii (2, 1.5)

5J

Now you try

Example 24

a $C = 60 + 30n$

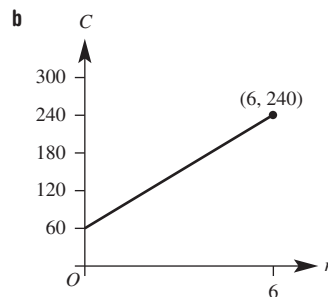

c \$150 d 5 hours

Exercise 5J

1 B

2 a i \$1200 ii \$1500 iii \$2200

b $A = 1000 + 100n$

3 a i dependent ii independent
 b i Volume ii Height iii Amount of money

4 a $W = 20x + 400$

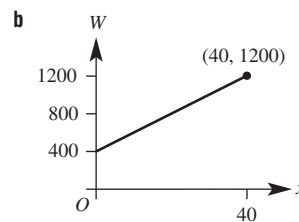

c \$640 d 30

5 a $C = 50n + 40$

b \$240 c \$640

6 a $C = 25n + 500$

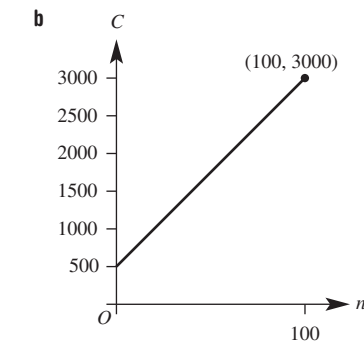

c \$1500 d 70

7 a $C = 120t + 300$

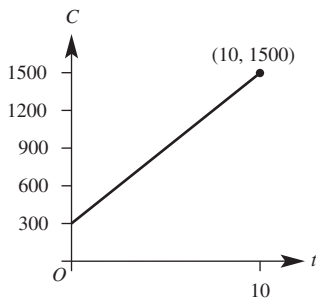

- b c \$1020 d 3 h
 8 a $F = 18t + 12$ b 3 min
 9 a $V = 4000 - 20t$ b 2200 L
 c 200 min d 175 min
 10 a 80 km/h
 b Rate changes; i.e. new gradient = 70, $d = 50 + 70t$
 11 a i 20 m/s ii 350 m iii 17.5 s
 b Increasing altitude (i.e. rising) at rate of 20 m/s
 12 a $d = 65t$

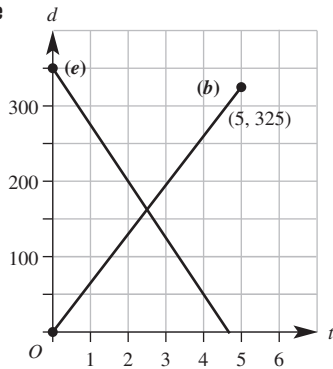

- c 350 km
 d 4 h and 40 min ($4\frac{2}{3}$ hours)
 f i 2.5 h ii 162.5 km

5K

Now you try

Example 25

a

x	-2	-1	0	1	2
y	16	4	0	4	16

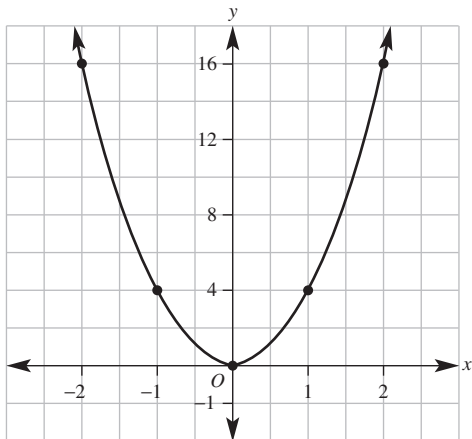

b

x	-2	-1	0	1	2
y	-5	-2	-1	-2	-5

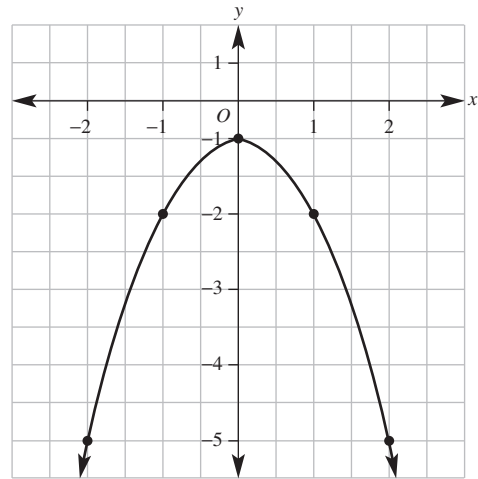

Exercise 5K

- 1 Parabola
 2 A, B, E
 3 a (0, -5) b (-1, 0) and (5, 0) c (2, -10)

4 a

x	-2	-1	0	1	2
y	12	3	0	3	12

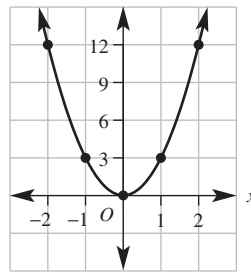

b

x	-2	-1	0	1	2
y	6	3	2	3	6

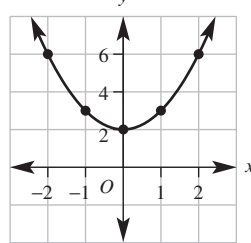

c

x	-2	-1	0	1	2
y	6	0	-2	0	6

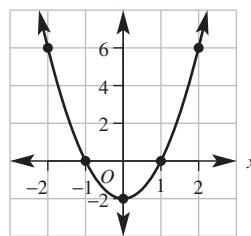

d

x	-2	-1	0	1	2
y	1	0	1	4	9

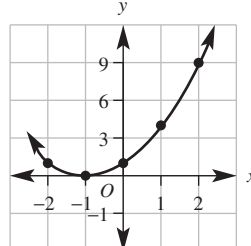

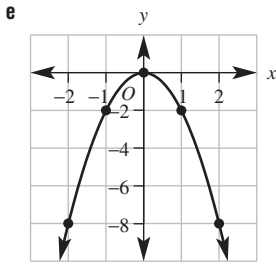

x	-2	-1	0	1	2
y	-8	-2	0	-2	-8

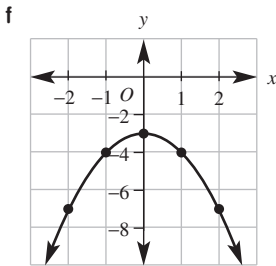

x	-2	-1	0	1	2
y	-7	-4	-3	-4	-7

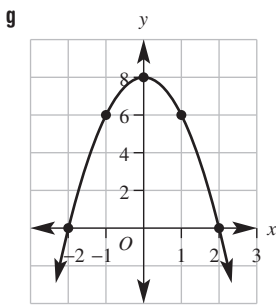

x	-2	-1	0	1	2
y	0	6	8	6	0

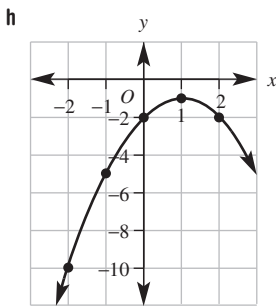

x	-2	-1	0	1	2
y	-10	-5	-2	-1	-2

- 5 a $y = -x^2$
 b $y = x^2 - 1$
 c $y = x^2 - 4$
 d $y = 4 - x^2$
- 6 a i Minimum, (0, -4) ii Minimum, (-1, -2)
 iii Maximum, (0, 1) iv Maximum, (0, 0)
 b The negative in front of x^2 creates a maximum turning point

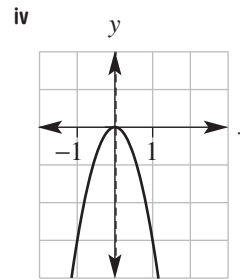
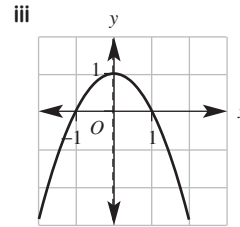
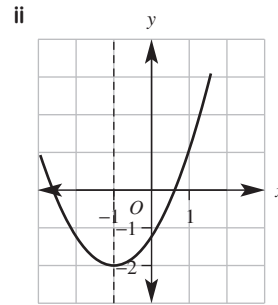
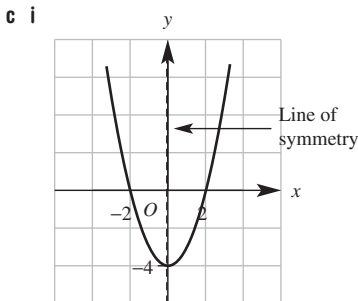

- 7 a C b A c E d B e D
- 8 a i 1 s, 3 s
 ii One time is on the way up and the other is on the way down.
 b i 2 s ii 12 m iii 4 s
- 9 a \$100
 b i \$110 ii \$121 iii \$133.10
 c No
 d i 10% ii 10% iii 10%
 e It is constant
 f \$146.41

Maths@Work: Trading in foreign currencies

1	x (input)	y (output)	Linear equation	Points
i	EUR	AUD	$y = 1.5687x$	(0, 0)(10, 15.687)
ii	GBP	AUD	$y = 2.0306x$	(0, 0)(10, 20.306)
iii	USD	CNY	$y = 6.5181x$	(0, 0)(10, 65.181)
iv	EUR	GBP	$y = 0.7725x$	(0, 0)(10, 7.725)
v	AUD	EUR	$y = 0.6375x$	(0, 0)(10, 6.375)
vi	AUD	USD	$y = 0.7158x$	(0, 0)(10, 7.185)
vii	AUD	SGD	$y = 1.0038x$	(0, 0)(10, 10.038)
viii	AUD	NZD	$y = 1.0753x$	(0, 0)(10, 10.753)

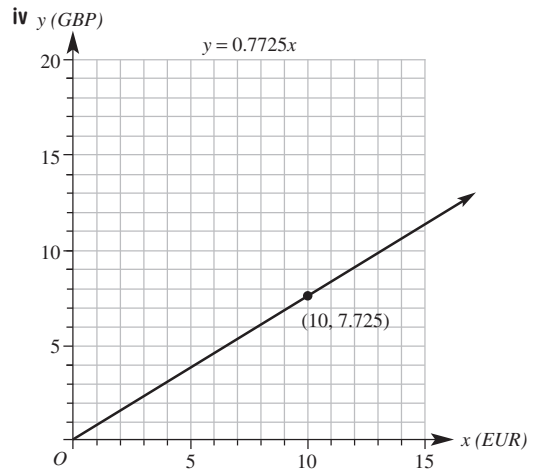
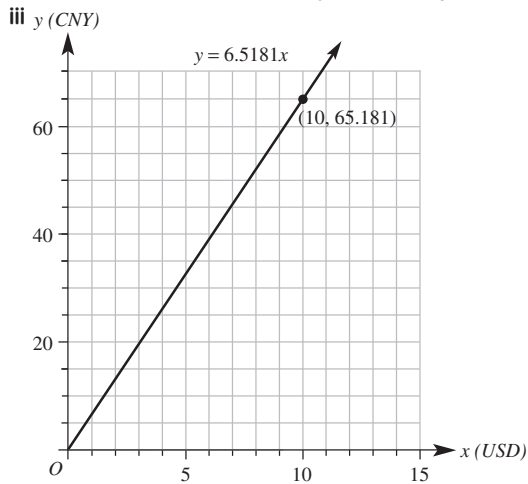
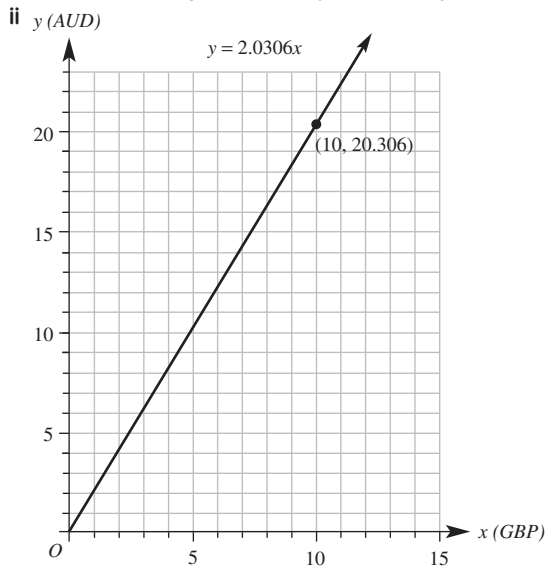
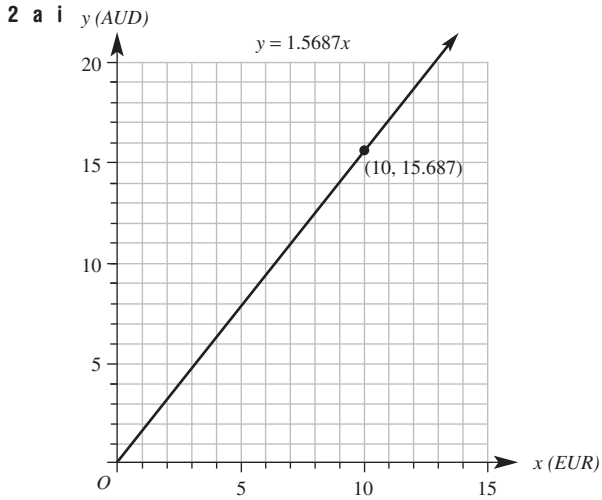

b The exchange rate is the gradient of each graph

c AUD exchange rates

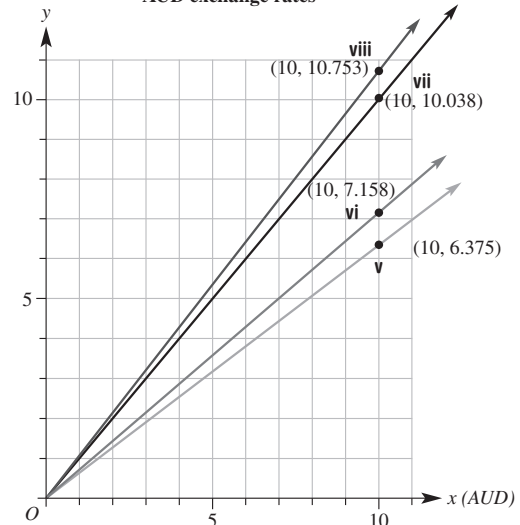

- d** The slope of the line increases as the exchange rate increases.
- 3 a** See figure at top of next page.
- b** $y = 0.6235x + 79.691$; x is the date in May; y is the Japanese exchange rate for 1 Australian dollar on that date.
- c** The gradient tells us that the exchange rate is increasing by 0.6235 Japanese yen per day in May.
- d** 85.926 Japanese yen
- e** 133565.25 Japanese yen
- f** Exchange rates can vary at any time and don't necessarily follow a trend line.

Puzzles and games

- 1 101
- 2 602
- 3 20 days
- 4 $(0.5, 5.5)$, diagonals intersect at their midpoint
- 5 Length $AB =$ length $AC = \sqrt{17}$
- 6 31 hours

3a

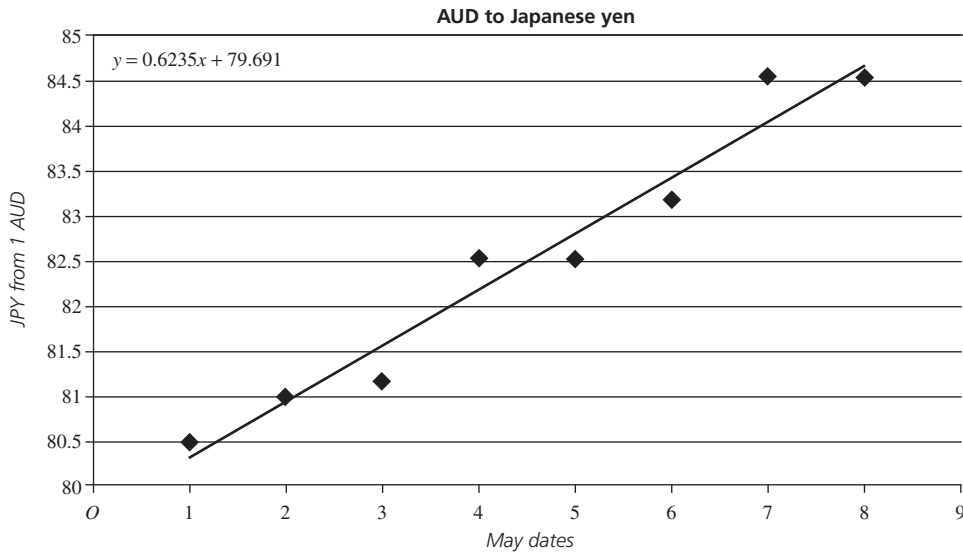

Short-answer questions

1

x	-2	-1	0	1	2	3
y	-7	-5	-3	-1	1	3

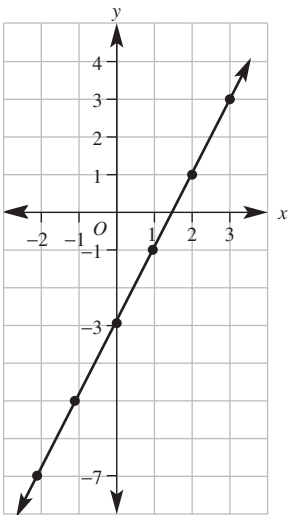

2 a -2 and 4

b 3 and -2

3 a

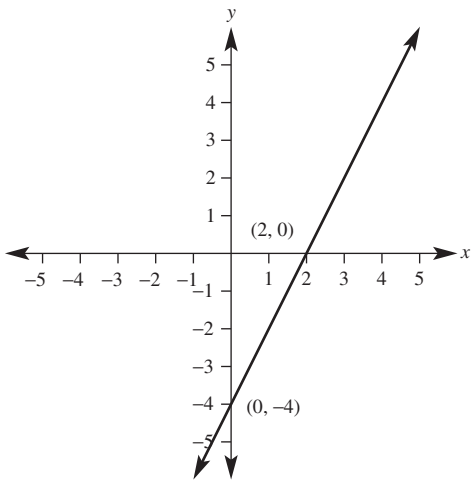

b

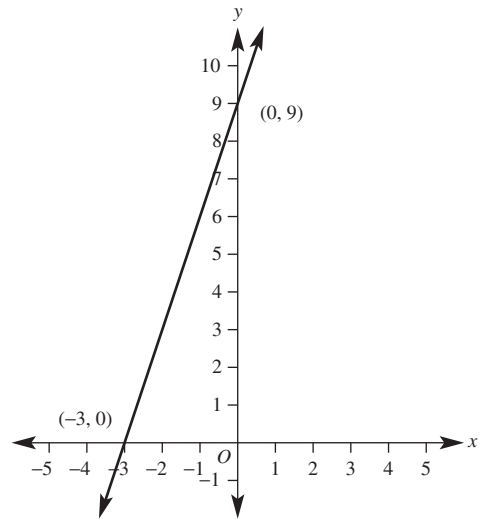

c

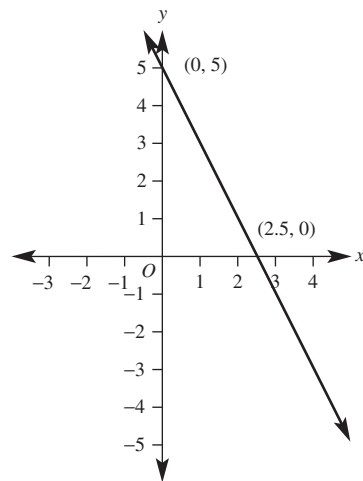

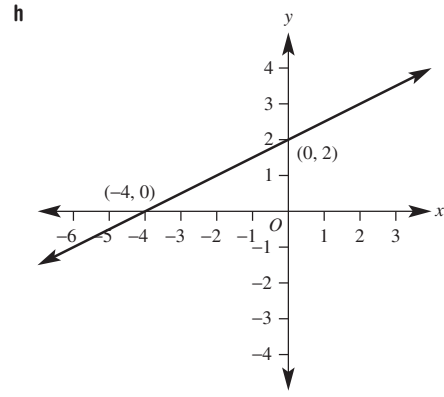
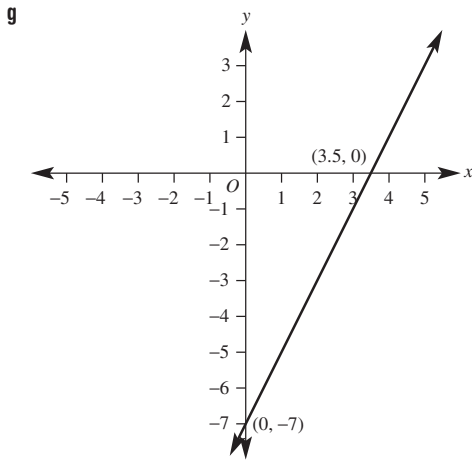
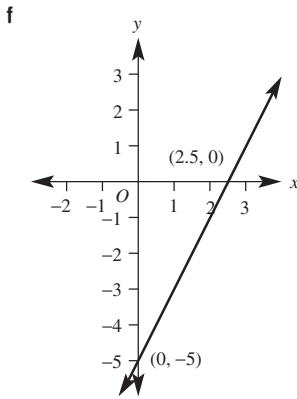
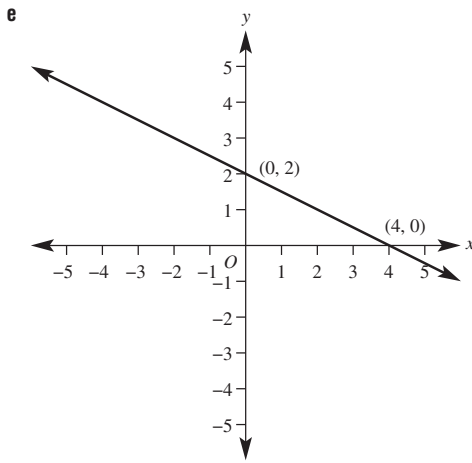
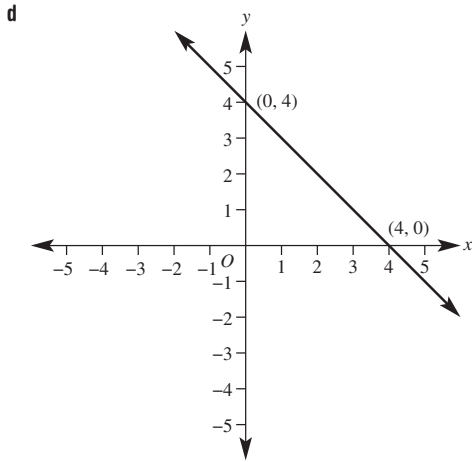

4 a Zero b Zero c Undefined

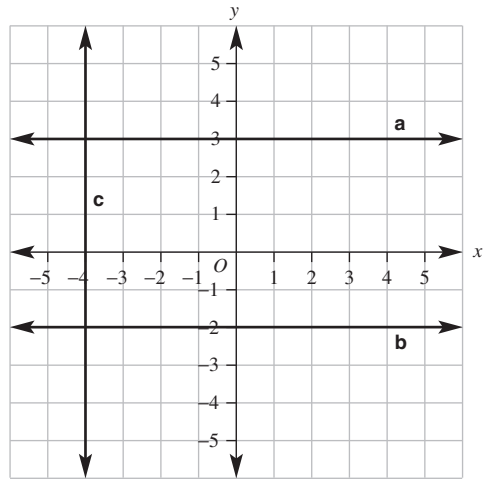

d Undefined e Positive f Negative

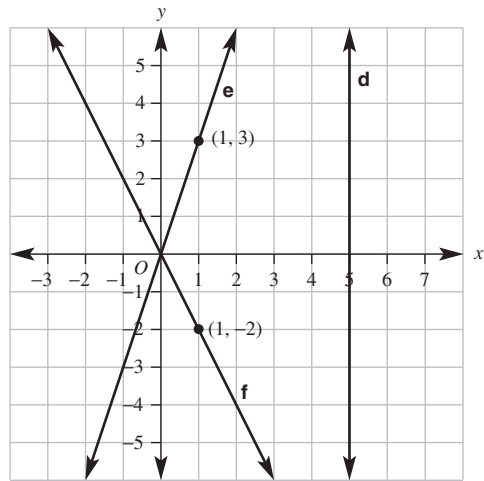

5 a 2 b -3
6 a 2 b -1
c 2 d $\frac{-10}{3}$

7 a 2000 L/h

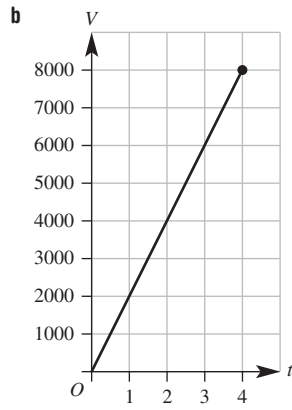

c $V = 2000t$

d 2.5 hours

8 a Gradient = 2, y-intercept = 3

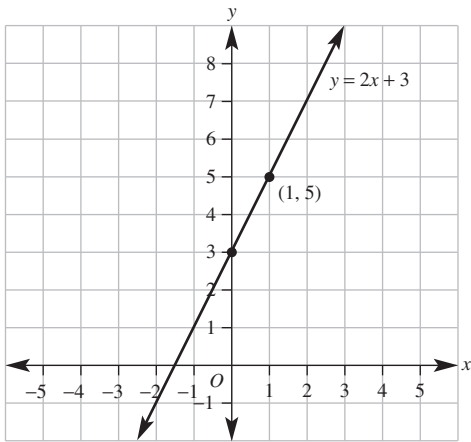

b Gradient = -3, y-intercept = 7

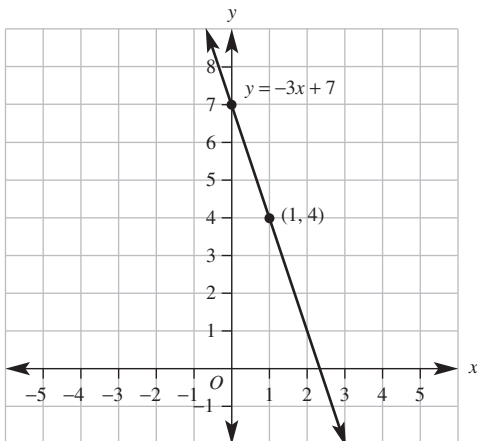

9 a $y = -2x + 6$, gradient = -2, y-intercept = 6

b $y = -\frac{1}{2}x + 2$, gradient = $-\frac{1}{2}$, y-intercept = 2

10 a $y = 2x - 2$

b $y = -3x + 6$

c $y = 3x - 2$

11 a $y = 3x + 1$

b $y = -2x + 3$

12 a $M(4, 6)$, 5.66

b $M(7.5, 4.5)$, 7.07

c $M(0, 4)$, 7.21

d $M(-3, 2.5)$, 9.85

13 a

x	-2	-1	0	1	2
y	8	2	0	2	8

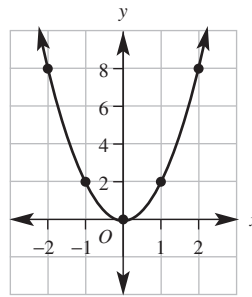

b

x	-2	-1	0	1	2
y	0	3	4	3	0

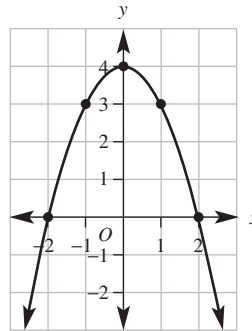

Multiple-choice questions

- 1 D 2 C 3 D 4 D 5 A 6 D
7 B 8 B 9 A 10 C

Extended-response questions

1 a $C = 50t + 100$

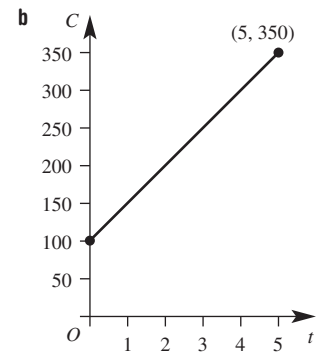

c \$300 d $2\frac{1}{2}$ hours

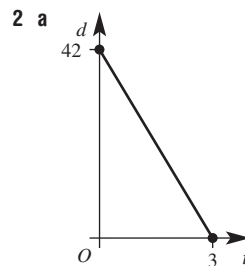

b 42 km c 3 hours d -14 e 14 km/h

Semester review 1

Reviewing number

Short-answer questions

- 1 a $\frac{19}{28}$ b $\frac{10}{10} = 1$ c $2\frac{3}{4}$ d $\frac{7}{9}$
 2 a $\frac{3}{8}$ b $1\frac{4}{5}$
 3 a 4.126 b 21.002 c 0.010
 4 a \$160, \$640 b \$320, \$480 c \$700, \$100
 5 a 5:3 b 55 km/h c 24 mL/h
 6 181.3 km
 7 4 m

Multiple-choice questions

- 1 B 2 D 3 D 4 C 5 C

Extended-response question

- a 24 km
 b i 14 km ii 2 p.m.

Financial mathematics

Short-answer questions

- 1 a 60% b 31.25% c 10% d 25%
 2 a \$9.60 b \$765 c \$11
 3 a 84 m b \$50.76
 4 4 h 48 min
 5 \$892
 6 \$67 484
 7 a \$72 b \$872

Multiple-choice questions

- 1 B 2 D 3 A 4 D 5 A

Extended-response question

- a \$17 500 b \$23 520 c 9 years d 27%

Linear equations

Short-answer questions

- 1 a $-2x + 7y$ b $-15mn$ c $\frac{y}{3}$
 2 a $x = 6$ b $x = 9$ c $m = \frac{3}{8}$ d $a = 3$
 3 a $2m + 1 = 15$ b \$7
 4 a 155 b 18

Multiple-choice questions

- 1 D 2 E 3 A 4 C 5 C

Extended-response question

- a $p + 12$
 b $p + (p + 12) = 38$; i.e. $2p + 12 = 38$
 c Michael scored 13 points and Chris 25 points

Pythagoras' theorem and trigonometry

Short-answer questions

- 1 a 6.3 b 15.1 c 9.9 d 6.3
 2 a 8.1 b 11.2 c 4.2 d 1.5
 e 53.1° f 29.5°

- 3 a 19.21 m b 38.7°
 4 a $x = 13$ b $y = 14.72$

Multiple-choice questions

- 1 B 2 D 3 A 4 C 5 A

Extended-response question

- a 17.75 m b 14.3° c 18.8 m

Linear relations

Short-answer questions

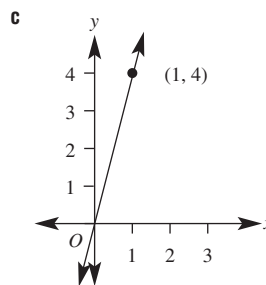
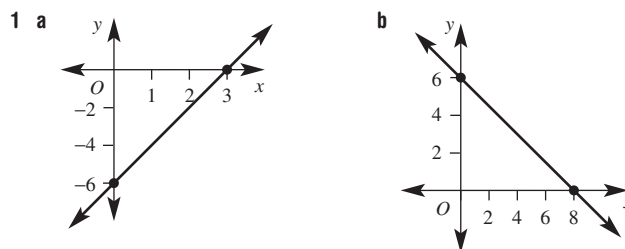

- 2 a $\frac{2}{3}$ b -3 c -2 d $\frac{4}{3}$

- 3 a $y = -3x + 6$ b $y = 3x - 1$

4

x	-2	-1	0	1	2
y	7	4	3	4	7

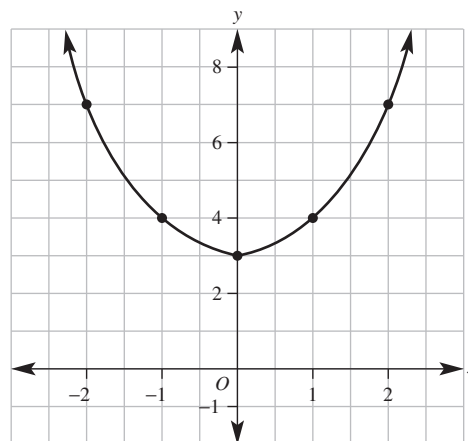

Multiple-choice questions

- 1 C 2 D 3 A 4 B 5 A

Extended-response question

- a 12 kg/h
 b $S = 180 - 12t$

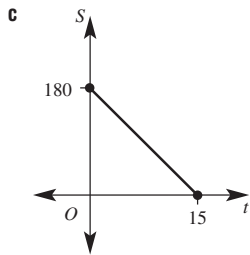

- d 15 hours
 e i $P = 40 + 25h$ ii \$415

Chapter 6

Warm-up quiz

- 1 a 4 cm^2 b 6 m^2 c 8 cm^2
 2 a 8 cm b 10 m c 18 cm
 3 a 3 b 6 c 27
 4 a Cylinder b Circle
 5 a 23 b 48 c 2.7 d 5.2134
 e 50 f 72.16
 6 7
 7 a 30 mm b 2000 cm c 1600 m d 2.3 cm
 e 3.167 km f 0.72 m g 20 km h 30 m
 i 0.0756 km
 8 a 30 cm^2 b 4 m^2 c 49 km^2 d 3 m^2
 e 24 cm^2 f 66 m^2 g $C = 31.42 \text{ m}$, $A = 78.54 \text{ m}^2$

6A

Now you try

Example 1

- a 240 cm b 42 cm

Example 2

- a 9 cm b 6 mm

Example 3

33.71 m

Exercise 6A

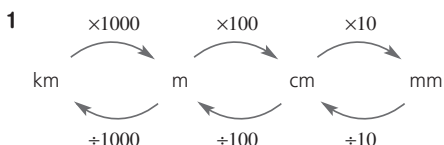

- 2 add
 3 a 7 b 26 c 2.1
 4 a 50 mm b 410 mm c 280 cm
 d 40 cm e 4600 m f 900 m
 g 52.1 cm h 3.6 cm i 2.4 m
 j 0.837 m k 7 km l 2.17 km
 5 825 cm, 2.25 cm
 6 a 15 mm b 31 m c 86 cm d 12 m
 e 27 cm f 24 mm g 18 km h 10 m
 i 42 cm
 7 a $x = 4$ b $x = 2.2$ c $x = 14$
 8 a $a = 3$, $b = 6$ b $a = 12$, $b = 4$ c $a = 6.2$, $b = 2$
 9 a 90 cm b 80 cm c 170 cm d 30.57 m
 e 25.5 cm f 15.4 cm
 10 108 m
 11 a 8000 mm b 110 m c 1 cm
 d 20 mm e 0.284 km f 62.743 km

- 12 a 86 cm b 13.6 m c 40.4 cm
 13 88 cm
 14 a i 96 cm ii 104 cm iii 120 cm
 b $P = 4(20 + 2x)$ or $P = 80 + 8x$
 c 109.6 cm

6B

Now you try

Example 4

23.88 m

Example 5

20.11 km

Example 6

10.71 cm

Exercise 6B

- 1 a Radius b Diameter c Circumference
 2 a 2.8 cm b 96 mm
 3 a $C = 2\pi r$ b $C = \pi d$
 4 a $\frac{1}{4}$ b $\frac{1}{2}$ c $\frac{3}{4}$
 5 a 50.27 m b 87.96 cm c 31.42 m
 d 6.91 m e 45.24 cm f 101.79 mm
 6 a 31.42 m b 78.54 cm c 9.42 mm
 d 12.57 km e 5.65 mm f 23.25 m
 7 a 12.56 m b 62.8 cm c 22 mm d 44 m
 8 a 10.28 m b 51.42 cm c 14.28 m
 d 10.00 cm e 20.05 m f 106.73 km
 9 28.27 m
 10 4.1 m
 11 a 12.57 cm b 102.83 mm c 41.06 m
 12 a 188.50 cm
 b i 376.99 cm ii 1979.20 cm
 c 531

6C

Now you try

Example 7

- a 3.2 m^2 b $400\,000 \text{ m}^2$

Example 8

- a 36 m^2 b 6.25 m^2 c 60 cm^2

Example 9

- a 56 cm^2 b 15 m^2

Exercise 6C

- 1 a 100 b 10 000 c 1 000 000
 2 a 6 b 16 c 12
 d 1 e 12 f 153
 3 a Rectangle b Rhombus/kite c Triangle
 d Trapezium e Parallelogram f Square
 4 a 200 mm^2 b 40 mm^2 c 5 cm^2
 d 3.1 cm^2 e $21\,000 \text{ cm}^2$ f 2000 cm^2
 g 21 m^2 h 0.37 m^2 i 1000 m^2
 j $4\,300\,000 \text{ m}^2$ k 3.2 km^2 l 0.0394 km^2
 5 a 24 m^2 b 10.5 cm^2 c 20 km^2
 d 25.2 m^2 e 15 m^2 f 36.8 m^2
 6 a 21 mm^2 b 12 cm^2 c 17 cm^2 d 63 m^2
 e 6.205 m^2 f 15.19 km^2
 7 $500\,000 \text{ m}^2$
 8 0.175 km^2

- 9 a 12.25 cm^2 b 3.04 m^2 c 0.09 cm^2 d 6.5 mm^2
 e 18 cm^2 f 2.4613 cm^2
- 10 0.51 m^2
- 11 a $1.5 \times 10^{10} (15\,000\,000\,000) \text{ cm}^2$ b 5 mm^2
 c 0.075 m^2
- 12 a i 1.5 m ii 1.5 m
 b 78 m^2
 c Yes

6D

Now you try

Example 10

0.50 m^2

Example 11

25.13 cm^2

Exercise 6D

- 1 a 4.1 m b 7.5 m c 3.8 cm
- 2 C
- 3 a $\frac{1}{4}$ b $\frac{1}{2}$ c $\frac{3}{4}$
- 4 a 12.57 m^2 b 113.10 cm^2 c 254.47 km^2
 d 60.82 mm^2 e 415.48 km^2 f $45\,238.93 \text{ cm}^2$
- 5 a 314.16 cm^2 b 60.82 m^2 c 17.35 cm^2
- 6 a 21.23 m^2 b 216.51 km^2 c 196.07 cm^2
- 7 a 12.57 m^2 b 157.08 cm^2 c 84.82 m^2
- 8 177 cm^2
- 9 a 2 m b 12.57 m^2 c 3.43 m^2 d 21.5%
- 10 12.89%
- 11 a 1.8 cm b 6.1 m c 2 km
- 12 31%

6E

Now you try

Example 12

$P = 32 \text{ m}$
 $A = 64 \text{ m}^2$

Example 13

$P = 142.83 \text{ cm}$
 $A = 171.68 \text{ cm}^2$

Exercise 6E

- 1 a Semicircle and rectangle
 b Triangle and semicircle c Rhombus and parallelogram
- 2 a $\frac{1}{2}$ b $\frac{1}{4}$ c $\frac{3}{4}$ d $\frac{1}{4}$
- 3 a 4 cm^2 b 3.14 cm^2 c 7.14 cm^2
- 4 a 46 m , 97 m^2 b 34 m , 76 m^2
 c 40 m , 90 m^2 d 18.28 m , 22.28 m^2
 e 19.42 m , 26.14 m^2 f 85.42 mm , 326.37 mm^2
- 5 a $P = 14.28 \text{ m}$, $A = 3.43 \text{ m}^2$
 b $P = 35.71 \text{ m}$, $A = 10.73 \text{ m}^2$
 c $P = 41.13 \text{ km}$, $A = 27.47 \text{ km}^2$
- 6 a 108 m^2 b 33 cm^2 c 98 m^2 d 300 m^2
 e 16 cm^2 f 22.5 m^2
- 7 189.27 m^2
- 8 68.67 cm^2
- 9 a 90 cm^2 b 15 m^2 c 9 m^2
 d 7.51 cm^2 e 7.95 m^2 f 180.03 cm^2
 g 8.74 mm^2 h 21.99 cm^2 i 23.83 mm^2
- 10 a 17 cm^2 b 3.5 cm^2 c 21.74 cm^2

- 11 a 37.70 m , 92.55 m^2 b 20.57 mm , 16 mm^2
 c 18.00 cm , 11.61 cm^2 d 12.57 m , 6.28 m^2
 e 25.71 cm , 23.14 cm^2 f 33.56 m , 83.90 m^2

6F

Now you try

Example 14

$\text{TSA} = 90 \text{ cm}^2$

Example 15

$\text{TSA} = 336 \text{ mm}^2$

Exercise 6F

- 1 a 6 b 6 c 5
- 2 a

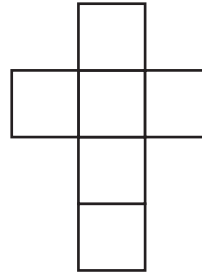

Cube

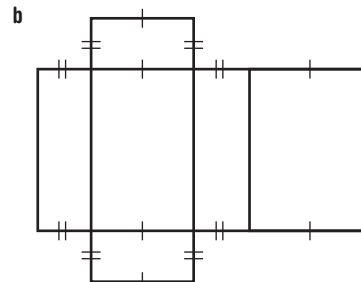

Rectangular prism

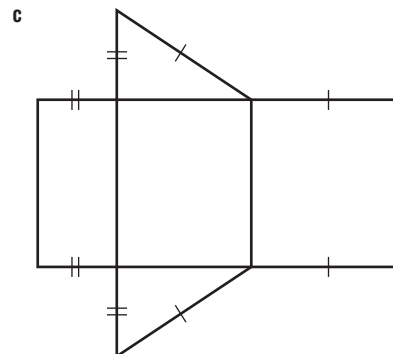

Triangular prism

- 3 a $\text{TSA} = 2 \times 8 \times 7 + 2 \times 8 \times 3 + 2 \times 7 \times 3$
 $= 112 + 48 + 42$
 $= 202 \text{ m}^2$
- b $\text{TSA} = 2 \times \frac{1}{2} \times 4 \times 3 + 5 \times 7 + 4 \times 7 + 3 \times 7$
 $= 12 + 35 + 28 + 21$
 $= 96 \text{ cm}^2$
- 4 a 52 m^2 b 242 cm^2 c 76 m^2 d 192 cm^2
 e 68.16 m^2 f 85.76 m^2
- 5 a 96 cm^2 b 240 m^2 c 199.8 cm^2
 d 238 cm^2
- 6 6 m^2
- 7 14.54 m^2

- 8 34 000 cm²
 9 a 44.4 m² b 4.44 L
 10 a [6, 10, 14, 18, 22, 26, 30, 34, 38] b $S = 4n + 2$
 c 402
 11 a 39 mm² b 224 cm² c 9.01 m²

Progress quiz

- 1 a 21 cm b 42 m
 2 a 25.13 cm b 31.42 m
 3 a 8.24 m b 300 mm c 1240 m d 36 000 cm²
 e 45 000 mm² f 0.0832 m²
 4 a 45 cm² b 40 m² c 40 mm² d 20 cm²
 5 a 153.9 mm² b 176.7 cm²
 6 a 46.3 cm b 127.2 cm²
 7 a i 33.4 cm ii 64.3 cm²
 b i 26 m ii 30 m²
 8 a 392 cm² b 360 cm²

6G

Now you try

Example 16

175.93 m²

Example 17

56.27 m²

Exercise 6G

- 1 a $2\pi rh$ b $2\pi r^2$
 2 a 25.13 m b 18.85 mm c 26.39 cm
 3 a

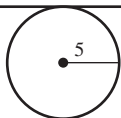
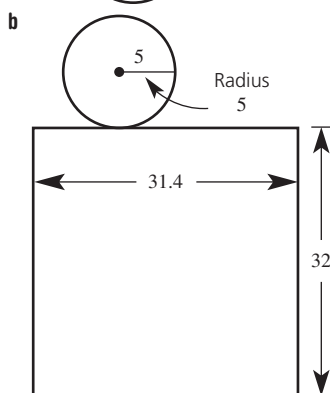
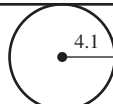
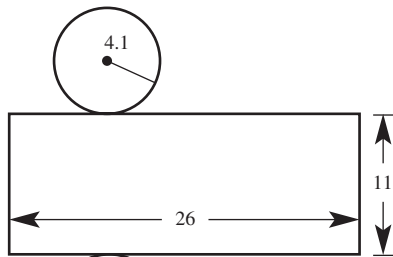

- 4 a 22 cm by 10 cm b 12.57 cm by 8 cm
 c 50.27 m by 5 m
 5 a 25.13 m² b 471.24 cm²
 c 50.27 m²

- 6 a 44.0 cm² b 603.2 cm² c 113.1 m²
 7 a 251.33 cm² b 207.35 mm² c 24.13 m²
 8 395.84 cm²
 9 a 54.56 m² b 218.23 m² c 63.98 cm² d 71.91 cm²
 e 270.80 m² f 313.65 km²
 10 7539.82 cm²
 11 Half cylinder is more than half surface area as it includes new rectangular surface.
 12 a 18 849.556 cm²
 b i 1.88 m² ii 37.70 m²
 c 239

6H

Now you try

Example 18

- a 600 mm³ b 4.52 m³

Example 19

40 m³

Example 20

15 mm³

Exercise 6H

- 1 a Square b Triangle c Rectangle
 d Trapezium e Hexagon f Triangle

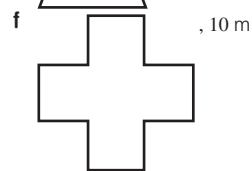
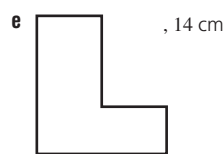
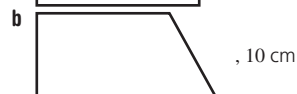
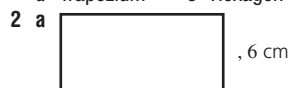

- 3 a 10 b 100 c 1000 d 1 000 000
 e 1 000 000 000 f 1000 g 1000 h 1
 4 a 3000 mm³ b 300 mm³ c 2 cm³ d 1000 cm³
 e 8 700 000 cm³ f 0.0059 m³ g 10 000 m³
 h 0.0000217 km³ i 0.43 m³
 5 a 3000 mL b 200 L c 3.5 L d 21 mL
 e 37 kL f 42.9 ML g 2 mL h 2000 cm³
 i 1000 L
 6 a 8 cm³ b 84 m³ c 21 mm³
 7 a 16 cm³ b 42.875 m³ c 15 cm³
 8 a 4 cm³ b 10.5 m³ c 11.96 cm³
 d 29 cm³ e 14.88 m³ f 8.1351 cm³
 9 a 75 m³ b 30 cm³ c 1.25 cm³
 10 1.6 L
 11 Yes, the tank only holds 20 L
 12 a 8 L b 0.36 L c 0.48 L
 13 a 55 m² b 825 000 L
 14 a $\frac{1}{3}$

61

Now you try

Example 21

- a 1696.46 cm³ b 22 167.08 mm³

Example 22

14 litres

Exercise 61

- 1 a 12.57 cm² b 8.04 m²
 c 78.54 cm² d 2.54 km²
- 2 a 2 L b 4.3 mL c 3700 cm³
 d 1000 L e 38 m³ f 200 mL
- 3 a $r = 4$ m, $h = 10$ m b $r = 2.6$ cm, $h = 11.1$ cm
 c $r = 2.9$ m, $h = 12.8$ m d $r = 9$ m, $h = 23$ m
 e $r = 5.8$ cm, $h = 15.1$ cm
 f $r = 10.65$ cm, $h = 10.4$ cm
- 4 a 226.19 cm³ b 18.85 m³ c 137.44 m³
 d 100.53 cm³ e 8.48 m³ f 68.05 m³
- 5 a 18 L b 503 L c 20 L d 2 L
- 6 a 1.571 m³ b 1571 L
- 7 Cylinder by 131 cm³
- 8 a 25.133 m³ b 25 133 L
- 9 37 699 L
- 10 A number of answers. Require $h = 2\pi r$.
- 11 a 502.65 cm³ b 1.02 m³
 c 294.52 m³ d 35 342.92 m³
 e 47.12 cm³ f 1017.88 cm³

Maths@Work: Vegetable and fruit growers

- 1 a i 0.89 ML ii 60 ML iii 800 ML iv 380 ML
 v 190 000 ML
 b i 9000 m³ ii 1200 m³ iii 120 000 m³
 iv 980 m³ v 12 000 000 m³
- 2 a 720 m³ b 400 m³
 c 1280 m³ d 10 000 m³
 e 38 400 m³
- 3 a 95058 L; 95 kL b 29452 L; 29 kL

Plant	Percentage moisture used by plant	Plant watering depth in mm
Onions	4%	16
Carrots	5%	30
Tomatoes	4%	48
Apple trees	6%	90
Banana trees	11%	66

5

Plant	Area of irrigation in m ²	Litres of water per plant per irrigation	Litres of water per 100 trees
Apple trees	0.1385	12	1247
Banana trees	0.3217	21	2123

Puzzles and games

- 1 a 35 b 19
 2 8
 3 314 m
 4 163.4 m²
 5 7.1 cm
 6 11
 7 100 L

Short-answer questions

- 1 a 380 cm b 1270 m c 4.8 cm d 2.73 cm²
 e 52 000 cm² f 10 000 cm³ g 53.1 cm³ h 3.1 L
 i 43 mL j 2830 L k 4 L l 1000 L
- 2 a 14 m b 51 mm c 16.2 cm
- 3 a 4 cm² b 1122 mm² c 30.34 mm²
 d 7.5 m² e 15 cm² f 3 cm²
- 4 a 2.5 m² b 37.4 m²
- 5 a $A = 28.27$ cm², $P = 18.85$ cm
 b $A = 1.57$ m², $P = 5.14$ m
 c $A = 2.36$ cm², $P = 6.71$ cm
- 6 a $P = 22.28$ m, $A = 30.28$ m²
 b $P = 45.56$ cm, $A = 128.54$ cm²
- 7 a 46 cm² b 114 m²
- 8 a 659.73 mm² b 207.35 m²
- 9 a 30 cm³ b 54 m³ c 31.42 mm³
 d 60 m³

Multiple-choice questions

- 1 B 2 C 3 E 4 B 5 A 6 D
 7 B 8 E 9 C 10 E

Extended-response questions

- 1 a 135 cm³
 b 174 cm²
 c \$43.50
 d i Yes, by ~ 119 cm³ ii Yes, by ~ 52 cm²
- 2 a 5.17 m b \$65 c 1.59 m², claim is correct

Chapter 7

Warm-up quiz

- 1
- $36 = 2 \times 2 \times 3 \times 3$
- 2 a 24, 1, 12, 2, 8, 3, 6, 4 b 45, 1, 15, 3, 9, 5
 c 2, 3 d 3, 5
- 3 a 7³ b 5² 2³ c 3² d 4¹ or 4
- 4 a 2³ b 2⁶ c 2⁵
- 5 a 25 b 100 c 1 d 5 e 1
- 6 a $3 \times 2 \times 2 = 12$ b $4 \times 3 \times 3 = 36$
 c $5 \times 2 \times 2 \times 2 = 40$ d $3 \times 10 \times 10 \times 10 \times 10 = 30\,000$
- 7 a 3⁴ b 2¹² c 9
- 8 a 0.003 b 0.04 c 0.000 002
 d 0.0008
- 9 a 3.73 b 24.62 c 18.37 d 4.40
- 10 a Tens b Thousandths c Millions
 d Tenths
- 11 a 5 b 4 c 2 d 4
- 12 a 38 b 2310 c 0.172
 d 0.0018 e 1000 f 10 000

7A

Now you try

Example 1

- a $6 \times 6 \times 6$ b $b \times b \times b \times b$
 c $mn \times mn$ d $3 \times x \times x \times x$

Example 2

a 8 b -27 c $\frac{9}{25}$

Example 3

a 9^3 b $2a^2$ c 11^2b^3

Example 4

a $\left(\frac{5}{7}\right)^4$ b $\left(\frac{2}{5}\right)^2 \times \left(\frac{4}{7}\right)^3$

Example 5

a $7^3x^3y^2$ b $2^37^2m^3s^2$ c $3^4a^4b^4$

Example 6

$2^2 \times 3 \times 5$

Example 7

a 36 b $-\frac{8}{27}$ c 33

Exercise 7A

- 1 a expanded b index c power
 d base e index, power or exponent
 f prime g prime factors
- 2 a 25 b 8 c 27 d 16
- 3 a 3 b 6 c 1.2 d -7 e $\frac{2}{3}$
- f y g w h t
- 4 a 3 b 8 c 7 d 4 e 11
 f 13 g 9 h 2
- 5 a 2, 3 b 3, 5 c 2, 3, 5 d 7, 11
- 6 a $4 \times 4 \times 4$ b $7 \times 7 \times 7 \times 7$
 c $3 \times 3 \times 3 \times 3 \times 3$ d $5 \times 5 \times 5$
 e $a \times a \times a \times a$ f $b \times b \times b$
 g $x \times x \times x$ h $xp \times xp \times xp \times xp \times xp \times xp$
 i $5a \times 5a \times 5a \times 5a$ j $3y \times 3y \times 3y$
 k $4 \times x \times x \times y \times y \times y \times y \times y$ l $pq \times pq$
 m $-3 \times s \times s \times s \times t \times t$
 n $6 \times x \times x \times x \times y \times y \times y \times y \times y$
 o $5 \times y \times z \times y \times z \times y \times z \times y \times z \times y \times z \times y \times z$
 p $4 \times a \times b \times a \times b \times a \times b$
- 7 a 36 b 16 c 243 d 12
 e -8 f -1 g 81 h 25
 i $\frac{8}{27}$ j $\frac{9}{16}$ k $\frac{1}{216}$ l $\frac{25}{4}$
 m $-\frac{8}{27}$ n $\frac{81}{256}$ o $\frac{1}{16}$ p $-\frac{3125}{32}$
- 8 a 3^3 b 8^6 c y^2 d $3x^3$
 e $4c^5$ f 5^3d^2 g x^2y^3 h 7^3b^2
- 9 a $\left(\frac{2}{3}\right)^4$ b $\left(\frac{3}{5}\right)^5$ c $\left(\frac{4}{7}\right)^2 \times \left(\frac{1}{5}\right)^4$
 d $\left(\frac{7x}{9}\right)^2 \times \left(\frac{y}{4}\right)^3$
- 10 a $3^3x^3y^2$ b $(3x)^2(2y)^2$ or $3^22^2x^2y^2$
 c $(4d)^2(2e)^2$ or $4^22^2d^2e^2$ d $(6by)^3$ or $6^3b^33y^3$
 e $(3pq)^4$ or $3^4p^4q^4$ f $(7mn)^3$ or $7^3m^3n^3$
- 11 a 2×5 b 2^3 c $2^4 \times 3^2$
 d 3×5^2 e 3×7^2 f $2^2 \times 5^3$
- 12 a $3 \times 3 \times a \times a \times a = 3^2a^3$
 b $5 \times 5 \times k \times k \times k = 5^2k^3$
 c $\frac{2}{7} \times \frac{2}{7} \times \frac{2}{7} = \left(\frac{2}{7}\right)^3$

d $3p^2q = 3 \times p \times p \times q$
 e $(abc) = a \times b \times c$
 f $4ab^2 = -2 \times (-2) \times a \times b \times b$

- 13 a 36 b -216 c 1 d $-\frac{8}{27}$
 e -18 f 15 g -36 h 216
 14 a 4 b 8 c 5 d 2
 e -4 f -2 g $\frac{1}{2}$ h 4 i 1

15 a

Time in minutes	Number of bacteria	Number in index form
0	1	2^0
1	$1 \times 2 = 2$	2^1
2	$2 \times 2 = 4$	2^2
3	$2 \times 2 \times 2 = 8$	2^3
4	$2 \times 2 \times 2 \times 2 = 16$	2^4
5	$2 \times 2 \times 2 \times 2 \times 2 = 32$	2^5
6	$2 \times 2 \times 2 \times 2 \times 2 \times 2 = 64$	2^6
7	$2 \times 2 \times 2 \times 2 \times 2 \times 2 \times 2 = 128$	2^7
8	$2 \times 2 \times 2 \times 2 \times 2 \times 2 \times 2 \times 2 = 256$	2^8
9	$2 \times 2 \times 2 \times 2 \times 2 \times 2 \times 2 \times 2 \times 2 = 512$	2^9
10	$2 \times 2 \times 2 \times 2 \times 2 \times 2 \times 2 \times 2 \times 2 \times 2 = 1024$	2^{10}

- b i 2 min ii 4 min iii 6 min
 c $2^{24} = 16\,777\,216$ cells

7B

Now you try

Example 8

a 2^{11} b 7^6 c 11^8 d 5^9

Example 9

a a^8 b m^3n^7

Example 10

y^6

Example 11

a $20a^5$ b $4b^5$ c $\frac{3}{4}x^2y = \frac{3x^2y}{4}$

Example 12

a a b $6m^2n^2$

Exercise 7B

- 1 a multiply, base, add
 b divide, base, subtract
- 2 a $3 \times 3 \times 3 \times 3 \times 3 \times 3 = 3^6$
 b $k \times k \times k \times k \times k = k^5$
- 3 a $\frac{5 \times 5 \times 5^1 \times 5^1 \times 5^1}{5^1 \times 5^1 \times 5^1} = 5^2$
 b $\frac{a \times a \times a \times a \times a^1 \cdot a^1}{a^1 \times a^1} = a^4$
- 4 a $6^{5+7} = 6^{12}$ b $a^{13+2} = a^{15}$
 c $5^{12-4} = 5^8$ d $m^{16-2} = m^{14}$

- 5 a 2^7 b 5^9 c 7^6 d 8^{10} e 3^8
 f 6^{14} g 3^3 h 6^5 i 5^3 j 10
 k 9^3 l $(-2)^2$
- 6 a x^7 b a^9 c t^8 d y^5
 e d^3 f y^7 g b^8 h q^{11}
 i a^5m^4 j k^5p^3 k x^6y^8 l m^7e^4
- 7 a a^2 b x^3 c q^{10} d d e b^5
 f a^5 g a^7 h y^8
- 8 a $7x^7y^5$ b $3x^9y^4$ c $5x^4y^9$
 d $4x^2y^5z$ e $15m^5$ f $8e^6f^4$
 g $20c^7d^2$ h $18y^2z^7$ i $3m$
 j $7x^3$ k $5y^2$ l $3a$
 m $3m^5$ n $\frac{w}{5}$ o $\frac{a}{5}$
 p $\frac{x^4}{9}$ q $\frac{4x^6y^3}{3}$ r $\frac{3st^2}{7}$
 s $\frac{4mn}{3}$ t $5x$
- 9 a b^6 b y^6 c c^7 d x e t
 f p^6 g d^6 h x^{10} i $4x^2y^3$ j $6b^2g$
- 10 a $\frac{m^5}{n^5}$ b $\frac{x^4}{y^2}$ c a^3b^3 d $\frac{6a^5}{c^7}$
 e $6f^6$ f $12x^4b^2$
- 11 a 12 b 8 c 3 d 3 e 1
 f 18 g 12 h 11 i 4 j 15
 k 2 l 39
- 12 a $7^2 = 49$ b 10 c $13^2 = 169$
 d $2^3 = 8$ e 101 f $200^2 = 40\,000$
 g $7 \times 31 = 217$ h $3 \times 50^2 = 7500$
- 13 a i $10a^{10}$ ii $9m^8$ iii $150m^5$
 iv $60x^6y^5$
 b i $4am$ ii $6xy^2$

7C

Now you try

Example 13

a a^{21} b $2b^8$

Example 14

a 1 b 2 c 3

Example 15

a^{17}

Example 16

a^2

Example 17

$\frac{3}{2}$

Exercise 7C

- 1 a multiply b 1
 2 a 16, 8, 4, 2, 1 b 64, 16, 4, 1
 3 a $4^2 \times 4^2 \times 4^2 = 4 \times 4 \times 4 \times 4 \times 4 \times 4 = 4^6$
 b $12^3 \times 12^3 = 12 \times 12 \times 12 \times 12 \times 12 \times 12 = 12^6$
 c $x^4 \times x^4 = x \times x \times x \times x \times x \times x \times x \times x = x^8$
 d $a^2 \times a^2 \times a^2 \times a^2 \times a^2 = a \times a \times a \times a \times a \times a \times a \times a \times a \times a \times a = a^{10}$
- 4 a 1 b 1 c 1 d 1
 e 1 f 1 g 1 h 1
 5 a y^{12} b m^{18} c x^{10} d b^{12}
 e 3^6 f 4^{15} g 3^{30} h 7^{10}
 i $5m^{16}$ j $4q^{28}$ k $-3c^{10}$ l $2j^{24}$

- 6 a 1 b 1 c 1 d 1
 e 1 f 1 g 1 h 1
 i 5 j -3 k 4 l -6
 m 1 n 3 o 4 p 0
- 7 a 4^7 b 3^9 c x d y^{13}
 e b^{14} f a^{10} g d^{24} h y^{16}
 i z^{25}
- 8 a b^6 b x^5 c y^6 d 7^2 e 4
 f 3^8 g 1 h y^3 i h^2
- 9 a 2 b $10x$ c $3x^8$ d $\frac{d^2e}{2}$
 e $\frac{2m^6n}{5}$ f $\frac{a^{12}}{8}$
- 10 5 ways: $(a^{16})^1 = a^{16}$, $(a^1)^{16} = a^{16}$, $(a^2)^8 = a^{16}$, $(a^8)^2 = a^{16}$, $(a^4)^4 = a^{16}$
- 11 a 4×5 not $4 + 5$, a^{20}
 b Power of 2 only applies to x^4 , $3x^8$
 c Power zero applies to whole bracket, 1
- 12 a i 400 ii 6400 iii 100
 b i 800 ii 12 800 iii 102 400
 c 13 years

7D

Now you try

Example 18

a $64x^3$ b $16y^{16}$

Example 19

a $\frac{a^2}{b^2}$ b $\frac{27a^3}{b^6}$

Example 20

a $16a^4b^2$ b $6a^{12}b^8$

Example 21

$\frac{27x^6}{8y^3z^9}$

Example 22

a $18a^2b^4$ b x

Exercise 7D

- 1 a $a^m \times b^m$ b $\frac{a^m}{b^m}$
- 2 a $ab \times ab \times ab \times ab$
 $= a \times a \times a \times a \times b \times b \times b \times b$
 $= a^4 \times b^4$
 b $\frac{x}{6} \times \frac{x}{6} \times \frac{x}{6}$
 $= \frac{x \times x \times x}{6 \times 6 \times 6}$
 $= \frac{x^3}{6^3}$
- 3 a x^5y^5 b 2^3m^3 c $a^4b^4c^4$ d $\frac{5^3}{k^3}$
 e $\frac{a^5}{m^5}$ f $\frac{2^4}{3^4} = \frac{16}{81}$
- 4 a $6a^2b^2$
 b $4x^3y^3$
 c $7 \times 2^2m^2 = 7 \times 4 \times m^2 = 28m^2$
 d $4 \times 3^2a^2b^2 = 4 \times 9a^2b^2 = 36a^2b^2$

- 5 a $8x^3$ b $25y^2$ c $64a^3$ d $9r^2$
 e $81b^4$ f $343r^3$ g $16h^8$ h $625c^8$
 i $27a^6$ j $49p^8$ k $25m^6$ l $9y^{20}$
- 6 a $\frac{p^3}{q^3}$ b $\frac{x^4}{y^4}$ c $\frac{64}{y^3}$ d $\frac{625}{p^8}$
 e $\frac{4}{r^6}$ f $\frac{s^6}{49}$ g $\frac{49}{x^6}$ h $\frac{1v^8}{100}$
 i $\frac{a^6}{125}$ j $\frac{m^8}{16}$ k $\frac{32m^5}{n^5}$ l $\frac{8a^6}{27}$
- 7 a $32x^{15}y^{10}$ b $9p^6q^{12}$ c $2x^6y^2$ d 1
 e $-27w^9y^3$ f $-4p^8q^2r^2$ g $25s^{14}t^2$ h $8x^{12}y^3z^9$
 i $24a^3b^6$
- 8 a $\frac{27n^9}{8m^{12}}$ b $\frac{16r^4}{n^4}$ c $\frac{9f^2}{64g^{10}}$ d $\frac{25w^8y^2}{4x^6}$
 e $\frac{9x^2}{4y^6g^{10}}$ f $\frac{27k^3m^9}{64n^{21}}$ g $-\frac{25w^8y^2}{4z^2x^6}$ h $\frac{9x^4y^6}{4a^{10}b^6}$
- 9 a $9ab^2$ b $27ab^6$ c $-12a^8b^8$ d $54x^6y^9$
 e $-64b^6c^{15}d^3$ f $8a^4$ g $9a^5$ h $-40a^{15}b^3$
 i $160m^{15}p^5t^{10}$ j $\frac{-27x^6}{125a^{15}b^9}$ k $a^{11}bc^5$ l $x^{11}y^2z$
- 10 a i 8 ii 125
 b $N = \frac{f^3}{8}$
 c i 27 ii 8
 d i 8 ii 2

7E

Now you try

Example 23

a $\frac{1}{6^4}$ b $\frac{7}{2^4}$

Example 24

a 10^3 b 5×9^4

Example 25

$\frac{7}{5^2} = \frac{7}{25}$

Example 26

$\frac{3}{100} = 0.03$

Example 27

a $\frac{1}{32}$ b 54 c $\frac{25}{16}$

Exercise 7E

1 a $\frac{1}{2^2}$ b $\frac{1}{3^2}$ c $\frac{1}{5^3}$ d $\frac{1}{3^3}$

2 a

Index form	3^4	3^3	3^2	3^1
Whole number or fraction	81	27	9	3

Index form	3^0	3^{-1}	3^{-2}	3^{-3}
Whole number or fraction	1	$\frac{1}{3}$	$\frac{1}{9} = \frac{1}{3^2}$	$\frac{1}{27} = \frac{1}{3^3}$

b

Index form	10^4	10^3	10^2	10^1
Whole number or fraction	10 000	1000	100	10

Index form	10^0	10^{-1}	10^{-2}	10^{-3}
Whole number or fraction	1	$\frac{1}{10}$	$\frac{1}{100} = \frac{1}{10^2}$	$\frac{1}{1000} = \frac{1}{10^3}$

- 3 a $10^{-4} = \frac{1}{10^4}$ b $3^{-2} = \frac{1}{3^2}$ c $7^{-3} = \frac{1}{7^3}$
- 4 a $\frac{1}{3^{-4}} = 3^4$ b $\frac{1}{7^{-6}} = 7^6$ c $\frac{1}{8^{-3}} = 8^3$
- 5 a $\frac{1}{5^2}$ b $\frac{1}{7^4}$ c $\frac{1}{8^3}$ d $\frac{1}{3^5}$ e $\frac{1}{9^2}$
 f $\frac{1}{10^3}$ g $\frac{1}{4^5}$ h $\frac{1}{2^3}$
- 6 a $\frac{3}{2^4}$ b $\frac{5}{4^3}$ c $\frac{7}{5^6}$ d $\frac{2}{3^4}$ e $\frac{4}{3^5}$
 f $\frac{9}{5^2}$ g $\frac{8}{7^3}$ h $\frac{6}{5^6}$ i $\frac{1}{4^2}$
- 7 a 2^4 b 3^2 c 4^3 d 6^5 e 5^3
 f 8^5 g 7^3 h 9^4
- 8 a 6×4^3 b 5×8^2 c 4×7^5 d 3×2^5
 e 12×5^4 f 6×10^3 g 7×9^4 h 7×10^6
- 9 a $\frac{6}{25}$ b $\frac{2}{9}$ c $\frac{4}{125}$ d $\frac{6}{7}$
 e $\frac{1}{250}$ f $\frac{1}{5}$ g $\frac{5}{16}$ h $\frac{4}{5}$ i $\frac{1}{9}$
- 10 a $\frac{2}{1000} = 0.002$ b $\frac{5}{100} = 0.05$
 c $\frac{7}{10} = 0.7$ d $\frac{3}{10\,000} = 0.0003$
 e $\frac{5}{10\,000} = 0.0005$ f $\frac{8}{100\,000} = 0.00008$
 g $\frac{2}{1\,000\,000} = 0.000002$
 h $\frac{4}{100\,000\,000} = 0.00000004$
- 11 a $\frac{1}{5}$ b $\frac{1}{9}$ c $\frac{1}{25}$ d $-\frac{1}{200}$
 e $\frac{1}{2}$ f $\frac{1}{36}$ g $\frac{1}{8}$ h 8
 i 16 j 64 k $\frac{64}{9}$ l $\frac{27}{64}$

12 a Negative power only applies to x , $\frac{2}{x^2}$

b $5 = 5^1$ has a positive power, $5a^{-4}$

c $\frac{2}{3^{-2}b^{-2}} = 2 \times 3^2 \times b^2 = 18b^2$

13 a 1.95 g b 3 486 784.401 t

Progress quiz

- 1 a $b \times b \times b \times b$ b $2 \times x \times x \times y \times y \times y$
 c $3x \times 3x \times 3x$ d $4 \times 4 \times 4 = 64$
 e $-5 \times (-5) \times (-5) \times (-5) = 625$ f $\frac{3}{5} \times \frac{3}{5} \times \frac{3}{5} = \frac{27}{125}$

2 a 5^2y^4 b $\left(\frac{2}{3}\right)^3 \times \left(\frac{5}{7}\right)^2$ c $4^3a^2b^4$

3 a $45 = 3^2 \times 5$ b $120 = 2^3 \times 3 \times 5$

4 a -27 b $\frac{1}{16}$ c 48

- 5 a 4^7 b 9^4 c x^8 d a^5b^5 e y^6
 f $3a^3$ g $12m^3n^7$ h $\frac{x^3y^2}{2}$ i $-2ab$
- 6 a x^8 b $5y^9$ c 1 d 1
 e -1 f 5
- 7 a $12mn^3$ b $\frac{x^2}{6}$ c $\frac{2a^2}{3}$
- 8 a $4x^2$ b $16m^{12}$ c $\frac{x^8}{81}$ d $-32a^3b^6$
 e $\frac{27a^6}{125}$ f $\frac{4a^4c^2}{49b^6}$
- 9 a $\frac{2y^2}{x^3}$ b $\frac{27x^2}{32}$
- 10 a $\frac{1}{5^2}$ b $\frac{3}{4^4}$ c 3^2 d 5×2^3
- 11 a $\frac{1}{81}$ b $\frac{5}{4}$ c 96 d 0.0006 e $\frac{125}{64}$

7F

Now you try

Example 28

7.1×10^4

Example 29

2.75×10^{-5}

Example 30

24 000

Example 31

0.0094

Exercise 7F

1

Scientific notation	Power of 10 expanded	Basic numeral
5×10^3	5×1000	5000
3×10^4	$3 \times 10\,000$	30 000
2×10^5	$2 \times 100\,000$	200 000
7×10^2	7×100	700
7×10^4	$7 \times 10\,000$	70 000
4×10^5	$4 \times 100\,000$	400 000

2

Scientific notation	Positive power	Fraction	Basic numeral
2×10^{-4}	$\frac{2}{10^4}$	$\frac{2}{10\,000}$	0.0002
3×10^{-2}	$\frac{3}{10^2}$	$\frac{3}{100}$	0.03
5×10^{-3}	$\frac{5}{10^3}$	$\frac{5}{1000}$	0.005
7×10^{-6}	$\frac{7}{10^6}$	$\frac{7}{1\,000\,000}$	0.000007
9×10^{-3}	$\frac{9}{10^3}$	$\frac{9}{1000}$	0.009
8×10^{-2}	$\frac{8}{10^2}$	$\frac{8}{100}$	0.08

- 3 a 10 000 b 1000 c 100 000 d 1000
 e 100 000 f 10 000
- 4 a Positive b Negative c Positive d Negative

- 5 a 4×10^4 b 2.3×10^{12} c 1.6×10^{10} d 7.2×10^6
 e 3.5×10^3 f 8.8×10^6 g 5.2×10^3 h 3×10^6
 i 2.1×10^4
- 6 a 3×10^{-6} b 4×10^{-4} c 8.76×10^{-3}
 d 7.3×10^{-10} e 3×10^{-5} f 1.25×10^{-10}
 g 8.09×10^{-9} h 2.4×10^{-8} i 3.45×10^{-5}
- 7 a 6×10^3 b 7.2×10^5 c 3.245×10^2
 d 7.86903×10^3 e 8.45912×10^3 f 2×10^{-1}
 g 3.28×10^{-4} h 9.87×10^{-3} i 1×10^{-5}
 j 4.601×10^8 k 1.7467×10^4 l 1.28×10^2
- 8 a 57 000 b 3 600 000 c 430 000 000
 d 32 100 000 e 423 000 f 90 400 000 000
 g 197 000 000 h 709 i 635 700
- 9 a 0.00012 b 0.0000046 c 0.0000000008
 d 0.0000352 e 0.3678 f 0.000000123
 g 0.00009 h 0.05 i 0.4
- 10 a 6×10^{24} kg b 4×10^7 m
 c 1×10^{-10} m d 1.5×10^8 km
 e 6.67×10^{-11} Nm²/kg² f 1.5×10^{-4} s
 g 4.5×10^9 years
- 11 a 4 600 000 000 km b 8 000 000 000 000 organisms
 c 384 000 km d 0.0038 m
 e 0.000000000000001 m f 720 000 people
- 12 a 1.62×10^9 km b 2.126×10^{-2} g
- 13 a 3.2×10^4 b 4.1×10^6 c 1.3×10^4 d 9.2×10^1
 e 6.1×10^{-2} f 4.24 g 2×10^{-5} h 4×10^{-6}

7G

Now you try

Example 32

- a 4 b 2 c 3

Example 33

- a 4.72×10^5 b 3.2×10^{-4}

Example 34

9.942×10^7

Example 35

1.653×10^{-2}

Exercise 7G

- 1 a i 300 ii 32 700 iii 18 400
 b i 0.1 ii 0.2 iii 21.0
 c i 268 000 ii 38 000 iii 4 061 000
- 2 42, 0.0071
- 3 a 57 260, 57 300, 57 000, 60 000
 b 0.003661, 0.00366, 0.0037, 0.004
- 4 a Yes b No c No d No e Yes
 f Yes
- 5 a 3 b 4 c 5 d 2
 e 3 f 2 g 3 h 3
 i 3 j 4 k 3 l 3
- 6 a 2.42×10^5 b 1.71×10^5 c 2.83×10^3 d 3.25×10^6
 e 3.43×10^{-4} f 6.86×10^{-3} g 1.46×10^{-2} h 1.03×10^{-3}
 i 2.34×10^1 j 3.26×10^2 k 1.96×10^1 l 1.72×10^{-1}
- 7 a 4.78×10^4 b 2.2×10^4 c 4.833×10^6
 d 3.7×10^1 e 9.95×10^1 f 1.443×10^{-2}
 g 2×10^{-3} h 9×10^{-2} i 1×10^{-4}
- 8 a 2.441×10^{-4} b 2.107×10^{-6}
 c -4.824×10^{15} d 4.550×10^{-5}
 e 1.917×10^{12} f 1.995×10^8
 g 3.843×10^2 h 1.804×10^{-11}
 i 1.524×10^8 j 3.325×10^{15}
 k 4.067×10^3 l -9.077×10^{-1}

- 9 a 9.3574×10^1 b 2.1893×10^5 c 8.6000×10^5
 d 8.6288×10^{-2} e 2.2985×10^{15} f 3.5741×10^{28}
 g 6.4000×10^7 h 1.2333×10^9 i 1.8293
 j 5.4459×10^{-1}
 10 1.98×10^{30} kg
 11 1.39×10^6 km
 12 $2421 \times 10^3, 24.2 \times 10^5, 2.41 \times 10^6, 0.239 \times 10^7, 0.02 \times 10^8$
 13 a 4.26×10^6 b 9.1×10^{-3} c 5.04×10^{11} d 1.931×10^{-1}
 e 2.1×10^6 f 6.14×10^{-11}
 14 a 5.40046×10^{12}
 b i 1.08×10^{13} ii 4.32×10^{13}

Maths@Work: Lab technician

- 1 a $1 \times 10^2 \mu\text{m}^3$ b $4 \times 10^3 \mu\text{m}^3$
 c $1.3 \times 10^2 \mu\text{m}^3$ d $1 \times 10^3 \mu\text{m}^3$ e $6 \times 10^5 \mu\text{m}^3$
 2 a 0.00012 m b 1.2×10^{-4} m
 3 a 2×10^{-9} g b 1×10^{-6} g c 3 g
 4 a 45 000 000 000 000 cells b 29 000 000 000 000 cells
 5 a 5.7×10^3 years b 4.5×10^9 years
 c 1.57×10^7 years d 1.6×10^{-4} seconds
 6 a 2.08×10^6 days b 1.64×10^{12} days c 5.73×10^9 days
 7 Just under 15.7 hours
 8 a 4.00×10^{-3} g b 1.05×10^3 g
 9 $\frac{1}{2}, \frac{1}{2^2}, \frac{1}{2^3}, \frac{1}{2^4}, \frac{1}{2^5}, \frac{1}{2^6}, \frac{1}{2^7}, \frac{1}{2^8}, \frac{1}{2^9}, \frac{1}{2^{10}}$ g
 $2^{-1}, 2^{-2}, 2^{-3}, 2^{-4}, 2^{-5}, 2^{-6}, 2^{-7}, 2^{-8}, 2^{-9}, 2^{-10}$ g

10 a

Radioactive isotope	Quantity remaining in mg			
	After 1 half-life	After 2 half-lives	After 4 half-lives	After 10 half-lives
Hydrogen-3	4.0000	2.0000	0.5000	0.0078
Carbon-11	32.0640	16.0320	4.0080	0.0626
Sodium-24	12.3650	6.1825	1.5456	0.0242
Iron-59	3.9300	1.9650	0.4913	0.0077
Radium-226	2.1250	1.0625	0.2656	0.0042

b

Radioactive isotope	Total time			
	For 2 half-lives	For 4 half-lives	For 6 half-lives	For 10 half-lives
Hydrogen-3	24.64	49.28	73.92	123.2
Carbon-11	40.6	81.2	121.8	203
Sodium-24	29.902	59.804	89.706	149.51
Iron-59	88.99	177.98	266.97	444.95
Radium-226	3200	6400	9600	16000

Puzzles and games

- 1 EXPONENTIAL
 2 a $10^8 = 100\,000\,000$ b $100^5 = 10\,000\,000\,000$
 4 $4a \times (3m)^3 \times \left(\frac{a}{6m}\right)^2 = 3a^3m$

5

Pile	Height	Value
1	2 mm	\$0.10
5	3.2 cm	\$1.60
10	1.024 m	\$51.20
15	32.77 m	\$1638.40
20	1.05 km	\$52 428.80
25	33.55 km	\$1 677 721.60
30	1073.74 km	\$53 687 091.20

- 6 14th day
 7 a 1.84×10^{11} tonnes
 b \$50 729 000 000 000 or more than 50 trillion dollars

Short-answer questions

- 1 a 3^4 b $2x^3y^2$ c $3a^2b^2$ d $\left(\frac{3}{5}\right)^3 \times \left(\frac{1}{7}\right)^2$
 2 a $3^2 \times 5$ b $2^2 \times 3 \times 5^2$
 3 a x^{10} b $12a^5b^6c$ c $\frac{24m^7n^4}{a^2b^2}$
 d a^9 e x^3y^2 f $\frac{2}{2}$
 4 a m^6 b $9a^8$ c $-32a^{10}b^5$
 d $3b$ e 2 f $\frac{a^6}{27}$
 5 a $\frac{1}{2^3}$ b $\frac{3}{4^5}$ c $\frac{6}{10^3}$
 d 4^2 e 6×5^3 f 2×10^5
 6 a k^6 b $6a^2m$ c $4a^{10}$
 d h^{16} e $\frac{a^8b^2}{5}$ f $45p^4q^2$
 7 0.0012, 35.4×10^{-3} , 3.22×10^{-1} , 0.4, 0.007×10^2 , 2.35
 8 a 324 b 172 500 c 0.2753
 d 0.00149
 9 a 2.25×10^7 people b 9.63×10^6 km²
 c 3.34×10^{-9} s d 2.94×10^{-7} m
 10 a 2.19×10^5 h b 3.6×10^7 months
 c 4.3×10^5 kg d 5×10^6 g

Multiple-choice questions

- 1 D 2 B 3 E 4 C 5 D 6 B
 7 D 8 C 9 C 10 E

Extended-response questions

- 1 a 1.2×10^{55} kg² b 4.3×10^{-5} m/s
 2 a i 5.79×10^7 km ii 1.50×10^8 km
 iii 7.78×10^8 km iv 1.43×10^9 km
 b i 2.41×10^{-1} ii 1.88 iii 2.95×10^1
 c i 4.87×10^{24} kg ii 6.42×10^{23} kg
 iii 1.90×10^{30} kg

Chapter 8

Warm-up quiz

- 1 a Obtuse b Acute c Reflex
 d Right e Straight f Revolution
 2 a 35 b 142 c 260
 3 a Isosceles b Equilateral c Scalene
 4 a Obtuse b Acute c Right
 5 a 60° b 75° each c 50°
 6 a Parallelogram, rectangle, kite
 b Parallelogram, rectangle, square, rhombus
 c Square, rectangle
 7 a $a = 60$ b $b = 110$ c $a = 60, b = 120$
 8 a Pentagon b Parallelogram c Trapezium

8A

Now you try

Example 1

- a 106° b 16°

Example 2

- a Obtuse scalene, $a = 35$ b Right isosceles, $b = 45$
 c Acute scalene, $c = 65$

Example 3

- a $b = 55$ b $a = 40$

Exercise 8A

- 1 a right b 180° c revolution
 d Obtuse e Acute f 180° g 90°
 h Supplementary i 180° j equal
- 2 a Isosceles triangle b Obtuse-angled triangle
 c Equilateral triangle d Isosceles triangle
 e Acute-angled triangle f Scalene triangle
 g Right-angled triangle h Right-angled isosceles triangle
- 3 a 50° b 90° c 101°
 d 202° e 180° f 360°
- 4 a i 125° ii 35°
 b i 149° ii 59°
 c i 106° ii 16°
 d i 170° ii 80°
 e i 91° ii 1°
 f i 158° ii 68°
 g i 142° ii 52°
 h i 115° ii 25°
 i i 133° ii 43°
 j i 103° ii 13°
- 5 a $a = 63$ b $a = 71$ c $a = 38$
 d $a = 147$ e $a = 233$ f $a = 33$
- 6 a Obtuse isosceles, $a = 40$ c Right-angled scalene, $c = 90$
 b Acute scalene, $b = 30$ e Obtuse isosceles, $e = 100$
 d Equilateral, $d = 60$
 f Right-angled isosceles, $f = 45$
 g Obtuse scalene, $g = 100$ h Equilateral, $h = 60$
 i Obtuse isosceles, $i = 120$ j Obtuse isosceles, $j = 35$
 k Right-angled scalene, $k = 90$
 l Acute scalene, $l = 70$
- 7 a i $\angle BAC$ ii Obtuse iii 120°
 b i $\angle PRQ$ ii Acute iii 30°
 c i $\angle XYZ$ ii Reflex iii 315°
 d i $\angle SRT$ ii Straight angle iii 180°
 e i $\angle ROB$ ii Obtuse iii 103°
 f i $\angle AOB$ ii Right iii 90°
- 8 a $s = 120$ b $t = 20$
 c $r = 70$ d $a = 60, x = 120$
 e $a = 100, b = 140$ f $c = 115, d = 65$
 g $x = 56$ h $x = 155$
- 9 $AO = BO$ (radii)
 $\triangle AOB$ is isosceles, 2 sides equal, $\angle AOB = 116^\circ$
 $\angle OAB = 32^\circ$, base angles of isosceles triangle
- 10 a 360° b 90° c 60° d 90°
 e 432° f 6° g 720° h 8640°
- 11 a 90° b 150° c 15° d 165°
 e 157.5° f 80° g 177.5° h 171°

8B

Now you try

Example 4

- a No. The two cointerior angles are not supplementary.
 b Yes. The alternate angles are equal.
 c Yes. The corresponding angles are equal.

Example 5

- a $a = 59$ (supplementary) b $b = 59$ (alternate)
 b $a = 128$ (cointerior) b $b = 128$ (vertically opposite)

Exercise 8B

- 1 a Corresponding b Alternate
 c Cointerior d Alternate
 e Cointerior f Corresponding
- 2 a equal b equal c supplementary
- 3 a No, alternate angles are not equal.
 b Yes, corresponding angles are equal.
 c Yes, alternate angles are equal.
 d No, cointerior angles don't add to 180° .
 e Yes, cointerior angles add to 180° .
 f Yes, corresponding angles are equal.
 g No, corresponding angles are not equal.
 h No, alternate angles are not equal.
 i No, cointerior angles do not add to 180° .
- 4 a $x = 125$, alternate angles in \parallel lines
 b $y = 110$, cointerior angles in \parallel lines
 c $r = 80$, corresponding angles in \parallel lines
 d $s = 66$, alternate angles in \parallel lines
 e $v = 106$, corresponding angles in \parallel lines
 f $q = 116$, cointerior angles in \parallel lines
- 5 a $a = 60, b = 120$ b $c = 95, d = 95$
 c $e = 100, f = 100, g = 100$ d $a = 110, b = 70$
 e $a = 100, b = 80, c = 80$
 f $e = 140, f = 140, d = 140$
- 6 $a = 40, b = 140, c = 40, d = 40, e = 140$
- 7 a $x = 70, y = 40$ b $t = 58, z = 122$
 c $u = 110, v = 50, w = 50$ d $x = 118$
 e $x = 295$ f $x = 79$
- 8 a 56 b 120 c 265
- 9 a 105° b 105° c 56°
 d 105° e 90° f 85°

8C

Now you try

Example 6

- a Parallelograms including rhombus, rectangle and square
 b Kite

Example 7

$x = 80$

Example 8

- a $m = 40$ b $n = 104$

Exercise 8C

- 1 Parallelogram, rhombus, rectangle, square, kite, trapezium
- 2 a Yes b No c Yes d Yes e No
- 3 a parallel b right c trapezium d equal
- 4 a Parallelogram, rectangle, kite b Rectangle, square
 c Square, rectangle d Square, rhombus, kite
 e Trapezium
 f Parallelogram, rhombus, kite, trapezium
- 5 a 115 b 159 c 30
 d 121 e 140 f 220
- 6 a $a = 110$ b $x = 70$ c $b = 54$
 d $a = 33$ e $y = 63$ f $a = 109$
- 7 a Yes b No c Yes d No
- 8 60°
- 9 A parallelogram has opposite sides parallel and equal and rectangles, squares and rhombi have these properties (and more) and are therefore all parallelograms.
- 10 a 110 b 55 c 120
 11 a 255 b 80 c 115
 d 37 e 28 f 111

Now you try

Example 9

$$S = 900^\circ$$

$$a = 250$$

Example 10

$$a = 144$$

Exercise 8D

- 1 a hexagon b regular c non-convex d $S = 180(n-2)$
 2 a 5 b 7 c 4 d 11 e 9 f 12
 3 a 720° b 1080° c 1620° d 900°
 4 a Convex quadrilateral b Non-convex hexagon
 c Non-convex heptagon d Non-convex decagon
 5 a 140 b 100 c 100 d 120
 6 a 110 b 150 c 210
 d 130 e 25 f 285
 7 a 90° b 108° c 140°
 d 120° e 128.57° f 135°
 8 a 16 b 25 c 102
 9 a Yes b Yes
 10 a 105 b 240 c 85 d 150
 11 a i No ii Yes iii No
 b i One ii Two iii Five
 c $(n-3)$

8E

Now you try

Example 11

- a RHS b SSS c SAS d AAS

Example 12

- a $x = 11, y = 5$ b $a = 71, b = 38$

Exercise 8E

- 1 a i Y ii X iii Z
 b i XY ii XZ iii YZ
 c i $\angle A$ ii $\angle B$ iii $\angle C$
 2 a size b $\triangle STU$ c SAS, RHS, AAS
 3 a $\triangle ABC \cong \triangle FGH$ b $\triangle DEF \cong \triangle STU$
 4 a SAS b AAS c RHS d SAS
 e SSS f RHS g AAS h SSS
 5 a $x = 3, y = 4$ b $x = 2, y = 6$
 c $a = 105, b = 40$ d $a = 65, b = 85$
 e $x = 2.5, b = 29$ f $a = 142, x = 9.21, b = 7$
 g $y = 4.2, a = 28$ h $a = 6.5, b = 60$
 6 a A and C b RHS
 7 a $\triangle ABC \cong \triangle STU$, RHS b $\triangle DEF \cong \triangle GHI$, SSS
 c $\triangle ABC \cong \triangle DEF$, SAS d $\triangle ABC \cong \triangle GHI$, AAS
 8 It is SAS; the hypotenuse is not given.
 9 No – they can all be different sizes, one might have all sides 2 cm and another all sides 5 cm.
 10 a SSS b Equal
 11 $\triangle PBR \cong \triangle FDE$
 $\triangle LMN \cong \triangle KIJ$
 $\triangle FGH \cong \triangle BCD$
 $\triangle MNO \cong \triangle RQP$

Progress quiz

- 1 a 27° b 117°
 2 a Right-angled scalene, $a = 55$
 b Acute-angled isosceles, $b = 40$
 c Obtuse-angled scalene, $c = 154$

- 3 a Alternate angles are not equal.
 b Co-interior angles are not supplementary.
 4 a $a = 55$ (supplementary angles), $b = 55$ (corresponding angles in parallel lines)
 b $a = 65$ (co-interior angles in parallel lines), $b = 65$ (vertically opposite)
 c $a = 40$ (alternate angles in parallel lines and angle sum of a triangle)
 5 a $a = 100$ b Parallelogram, $b = 58$
 c Kite, $c = 80$
 6 a $S = 720, a = 109$ b $S = 540, a = 108$
 7 a SAS b SSS
 8 $x = 6, y = 40$

8F

Now you try

Example 13

- a 2.5 b 40 c 13

Example 14

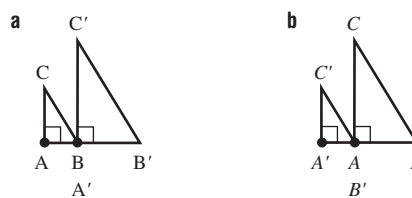

Exercise 8F

- 1 a image b shape c \parallel or \sim
 2 a $\angle F$ b $\angle D$ c GH d AE e 2
 3 a OA' is double OA b OB' is double OB
 c OC' is double OC d 2 e Yes
 4 a OA' is a quarter of OA b OD' is a quarter of OD
 c $\frac{1}{4}$ d Yes
 5 a i 2 ii 14 iii 10
 b i 1.5 ii 10.5 iii 8
 c i 1.5 ii 45 iii 24
 d i 2.5 ii 1 iii 1.4
 e i 2.5 ii 0.6 iii 2
 f i 1.75 ii 3.5 iii 3
 6 a $A'B'C'$ should have sides $\frac{1}{3}$ that of ABC .
 b $A'B'C'$ should have sides double that of ABC .
 7 b i $A'B'C'D'$ should have sides lengths $\frac{1}{2}$ that of $ABCD$
 ii $A'B'C'D'$ should have side lengths 1.5 times that of $ABCD$
 8 a yes b 8 cm c 25 cm
 9 3.7 cm
 10 a i 2 ii (0, 0)
 b i $\frac{1}{2}$ ii (0, 0)
 c i $\frac{1}{2}$ ii (3, 0)
 d i 3 ii (1, 0)
 11 a All angles of any square equal 90° , with only 1 side length
 b All angles in any equilateral triangle equal 60° , with only 1 side length
 c The ratio of the length to the width may vary between different rectangles.
 d 2 isosceles triangles do not have to have the same size equal angles.
 12 a 12.7 cm b 3 cm c 3 m
 13 a 100 000 cm = 1 km b 24 cm

8G

Now you try

Example 15

- a SAS b AAA c SSS d RHS

Example 16

- a AAA b 2.5 c 4.8

Exercise 8G

- 1 a SAS, AAA, and RHS b shape, size
 c triangle d similar
- 2 a E b C c DF
 d BC e $\angle A$ f $\angle E$
- 3 a AAA b RHS c SSS d SAS
 e RHS f AAA g SAS h SSS
- 4 a $\triangle ABC \parallel \triangle GHI$ b $\triangle ABC \parallel \triangle MNO$
 c $\triangle ABC \parallel \triangle ADE$ d $\triangle HFG \parallel \triangle HJI$
 e $\triangle ADC \parallel \triangle AEB$ f $\triangle ABD \parallel \triangle ECD$
- 5 2.5
- 6 a AAA b 1.5 c 12
- 7 a RHS b 2.5 c 8
- 8 2 m
- 9 a $\triangle DEF$ b $\triangle DEF$ c $\triangle ABC$ d $\triangle DEF$
- 10 a i AAA ii 6.5
 b i AAA ii 10
 c i AAA ii 24
- 11 $\angle ACB = 25^\circ$, AAA

12 a

Triangle	Original	Image 1	2	3
Length scale factor	1	2	3	4
Area	4	16	36	64
Area scale factor	1	4	9	16

- b Area scale factor = (length scale factor)²
 c i 100 ii 400 iii 10 000

8H

Now you try

Example 17

- a AAA b 10 m

Exercise 8H

- 1 a Two b AAA c 2 d 12
- 2 $\angle C$
- 3 a $\angle ACB$ and $\angle ECD$
 b $\angle BAC = \angle DEC$ and $\angle CBA = \angle CDE$
- 4 a 3 b 3.6 m
- 5 a AAA b 40 m
- 6 6 m
- 7 a AAA b 7.5 m
- 8 a To create two similar triangles
 b AAA c 24 m
- 9 7.2 m
- 10 20 m
- 11 a i 3.6 m ii 9 m iii 2.7 m
 b i 5.4 m ii 6.3 m
 c i 4 m ii 6 m
- 12 $\frac{55}{6}$
- 13 a 3
 b i $BD = \frac{25}{3}$ ii $AC = 4$ iii $AB = \frac{20}{3}$

Maths@Work: Animator

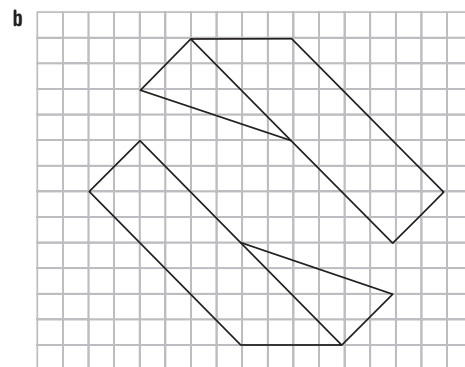
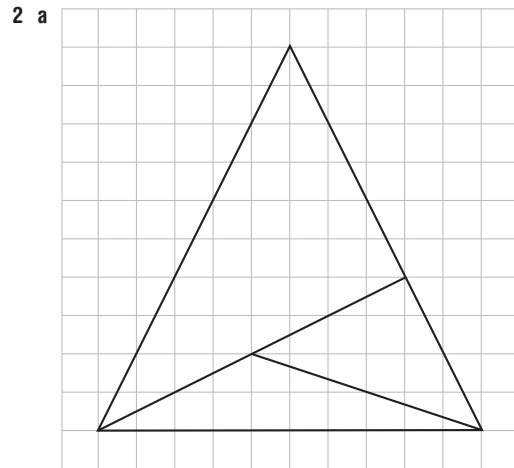

- 3 12 pairs of congruent triangles; 2 pairs of similar triangles
 4 30° clockwise; 60° clockwise; 20° clockwise
 5 Answers will vary.

Puzzles and games

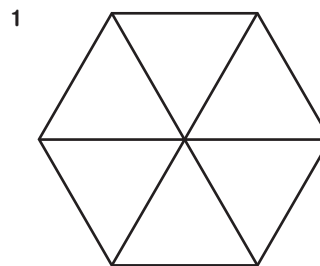

- 2 110
 3 10
 4 11
 5 Base of altitudes (an altitude is a line through a vertex that meets the opposite side at right angles)
- 6 b i $\frac{l}{2}$ ii $\frac{l}{4}$ iii $\frac{l}{128}$
 c i $\frac{3}{4}$ ii $\frac{9}{16}$ iii $\frac{243}{1024}$
 d Zero

Short-answer questions

- 1 a $a = 142$ b $b = 40$ c $c = 120$
 2 a Acute-angled isosceles, $x = 50, y = 80$
 b Right-angled, $x = 25$
 c Obtuse-angled scalene, $x = 30, y = 110$

- 3 a No – corresponding angles are not equal.
 b Yes – cointerior angles are supplementary.
 c Yes – alternate angles are equal.
- 4 a $a = 60, b = 120, c = 120$ b $a = 40, b = 80$
 c $a = 99, b = 20$
- 5 a Square, rectangle b Square, rhombus, kite
 c Parallelogram, rectangle, kite
- 6 a $a = 70, b = 110$ b $x = 115$
 c $x = 15$
- 7 a $x = 95$ b $a = 120$ c $x = 135$
- 8 a SSS, $x = 60$ b Not congruent
 c RHS, $x = 12$ d AAS, $x = 9$
- 9 For image $\triangle A'B'C', OA' = 3OA, OB' = 3OB, OC' = 3OC$
- 10 a Yes, SAS b Yes, AAA
 c Not similar d Yes, RHS
- 11 a 3.5 b 4 c 18
- 12 a 3 b 4.8 m

Multiple-choice questions

- 1 D 2 A 3 B 4 D 5 C 6 D
 7 E 8 B 9 D 10 A

Extended-response questions

- 1 a Isosceles, right-angled
 b $a = 40$, angle sum in isosceles triangle
 $b = 70$, angles in parallel lines
 $c = 120$, angle sum of a quadrilateral
 $d = 25$, supplementary angles
 $e = 65$, angle sum of a triangle
- 2 a $\angle ECD$
 b $\angle ABC = \angle EDC$ (given 90°)
 $\angle ACB = \angle ECD$ (vertically opposite)
 $\therefore \triangle ABC \parallel \triangle EDC$ (AAA)
 c 19.8 m

Chapter 9

Warm-up quiz

- 1 a 4 b 6 c -2 d -7
 2 a 5 b 2 c 1 d -6
 3 a -10 b 16 c 11 d -100
 e 2 f 48 g -20 h -70
- 4 a $2x + 6$ b $3a - 15$ c $12x - 8xy$
 d $3 - 6b$
- 5 a 2 b 6 c $2x$ d $3y$
 e $5x$ f ab
- 6 a $2(a + 3)$ b $3(x + 4y)$
 c $5x(x - 3)$ d $2m(2 - 3n)$
- 7 a $\frac{5}{7}$ b $-\frac{1}{9}$ c $\frac{7}{6}$ d $-\frac{1}{8}$
- 8 a $\frac{8}{15}$ b $\frac{1}{2}$ c $\frac{1}{3}$ d 1
 e 2 f $\frac{3}{2}$ g $\frac{9}{8}$ h $\frac{7}{12}$
- 9 a $3x + 2$ b $x + 4$ c $-10 - 3x$
- 10 $x(x + 2), x^2 + 2x$

9A

Now you try

Example 1

- a $2m - n$ b $-2x^2y - xy$

Example 2

a $-15xy^2$ b $\frac{a}{2}$

Example 3

a $-3x - 6$ b $6x^2 - 4x$

Exercise 9A

- 1 a i \$11x ii 50n cents
 b i $x + y$ ii $b + g$
 c $\$(50 + 60n)$
- 2 a 5 b -2 c -7 d No
 e -10 f 6
- 3 a $5 + 2x$ b $4a - 7$ c $y^2 - 1$
 d xz e $a^2 + b^2$ f $\sqrt{x + 8}$
- 4 a -a b 11x c 8ab d $-4xy$
 e $a - 1$ f $2x - 4y$ g $6x - 4y$ h 2ab
 i $-4a^2b - 3$ j $-3xy$ k $12a^2$ l $st^2 - st$
- 5 a 15x b 14a c $-8xy$ d $-42a^2$
 e $-3ab^2$ f $-12a^2b^2$ g 2x h 7
 i 3 j 2a k $\frac{10}{a}$ l 4x
 m ab n $\frac{3a}{c}$ o $\frac{1}{3y}$
- 6 a $3x + 6$ b $8 + 2x$ c $-3x - 12$
 d $-6x - 6$ e $-2x + 6$ f $-x^2 - x$
 g $-6y + 9y^2$ h $-7a^2 + 7ab$ i $2x + 1$
 j $4 - x$ k $3 - 4x$ l $2x + 6$
 m $4x - 9$ n $-17x - 3$ o $13x - 40$ p $3x - 11$
- 7 a i $2a + 2b$ or $2(a + b)$ ii ab
 b i 4x ii x^2
 c i $a + b + c$ ii $\frac{1}{2}ab$
- 8 a 4 b 24 c -1 d 10
 e 13 f -8 g $\frac{25}{2}$ h 1
 i -2 j 35 k -12 l $\sqrt{13}$
- 9 a i \$260 ii \$820
 b $100 + 80n$
- 10 a $2x^2 - x$ b $x^2 + 6x$ c $x^2 + x + 2$
- 11 a $-3x + 3$ b $\frac{a}{2}$ c $\frac{2}{a}$ d 9
- 12 a i \$120 ii \$600
 b i \$140 ii \$540
 c \$60n.
 d $\$(40 + 50n)$
 e 4 hours

9B

Now you try

Example 4

$x^2 + 11x + 18$

Example 5

a $x^2 - 3x - 18$ b $3x^2 - 14x + 8$ c $18x^2 - 9x - 20$

Exercise 9B

- 1 a $x^2, 2x, 3x, 6$ b $x^2 + 3x + 2x + 6 = x^2 + 5x + 6$
- 2 a $2x^2, 2x, 3x, 3$
 b $(2x + 3)(x + 1) = 2x^2 + 2x + 3x + 3$
 $= 2x^2 + 5x + 3$
- 3 a $x^2 + 5x + x + 5 = x^2 + 6x + 5$
 b $x^2 + 2x - 3x - 6 = x^2 - x - 6$
 c $21x^2 + 6x - 14x - 4 = 21x^2 - 8x - 4$
 d $12x^2 - 16x - 3x + 4 = 12x^2 - 19x + 4$

- 4 a $x^2 + 7x + 10$
 b $b^2 + 7b + 12$
 c $t^2 + 15t + 56$
 d $p^2 + 12p + 36$
 e $x^2 + 15x + 54$
 f $d^2 + 19d + 60$
 g $a^2 + 8a + 7$
 h $y^2 + 12y + 20$
 i $m^2 + 16m + 48$
- 5 a $x^2 - x - 12$
 b $x^2 + 3x - 10$
 c $x^2 - 4x - 32$
 d $x^2 - 4x - 12$
 e $x^2 + 9x - 10$
 f $x^2 + 2x - 63$
 g $x^2 + 5x - 14$
 h $x^2 - 3x + 2$
 i $x^2 - 9x + 20$
 j $8x^2 + 26x + 15$
 k $6x^2 + 7x + 2$
 l $15x^2 + 17x + 4$
 m $6x^2 + x - 15$
 n $24x^2 + 23x - 12$
 o $6x^2 - x - 2$
 p $10x^2 - 31x - 14$
 q $6x^2 + 5x - 6$
 r $16x^2 - 16x - 5$
 s $18x^2 - 27x + 10$
 t $15x^2 - 11x + 2$
 u $21x^2 - 37x + 12$
- 6 a i $x + 10$ ii $x + 7$
 b $x^2 + 17x + 70$
 c $108m^2$
- 7 a $x^2 + 9x + 20$
 b i $56m^2$ ii $36m^2$
- 8 a i $2x + 3$ ii $2x + 2$
 b $4x^2 + 10x + 6$
 c $20m^2$
- 9 a 3 b 2 c 6, 6 d 2, 18
 e 2, 6 f 3, 15
- 10 a $a^2 + ac + ab + bc$ b $a^2 + ac - ab - bc$
 c $ab + bc - a^2 - ac$ d $2x^2 - 3xy - 2y^2$
 e $2a^2 - ab - b^2$ f $6x^2 + xy - y^2$
- 11 a $2x^2$ b $2x^2 - 30x + 100$
- 12 a i $15 - 2x$ ii $10 - 2x$
 b $150 - 50x + 4x^2$
 c $66m^2$
 d $x = 2.5$

9C

Now you try

Example 6

- a $x^2 + 16x + 64$ b $x^2 - 10x + 25$

Example 7

$25x^2 - 30x + 9$

Exercise 9C

- 1 a $x^2, 3x, 3x, 9$ b $x^2 + 6x + 9$
 c $(x + 3)(x + 3) = x^2 + 3x + 3x + 9 = x^2 + 6x + 9$
- 2 a $+4x + 16 = x^2 + 8x + 16$ b $+5x + 25 = x^2 + 10x + 25$
 c $-2x + 4 = x^2 - 4x + 4$ d $-7x + 49 = x^2 - 14x + 49$
- 3 a i $x^2 + 6x + 9$ ii $x^2 + 22x + 121$
 b i $x^2 - 4x + 4$ ii $x^2 - 18x + 81$
- 4 a $x^2 + 2x + 1$ b $x^2 + 6x + 9$
 c $x^2 + 4x + 4$ d $x^2 + 10x + 25$
 e $x^2 + 8x + 16$ f $x^2 + 18x + 81$
 g $x^2 + 14x + 49$ h $x^2 + 20x + 100$
 i $x^2 - 4x + 4$ j $x^2 - 12x + 36$
 k $x^2 - 2x + 1$ l $x^2 - 6x + 9$
 m $x^2 - 18x + 81$ n $x^2 - 14x + 49$
 o $x^2 - 8x + 16$ p $x^2 - 24x + 144$
- 5 a $4x^2 + 4x + 1$ b $4x^2 + 20x + 25$
 c $9x^2 + 12x + 4$ d $9x^2 + 6x + 1$
 e $25x^2 + 20x + 4$ f $16x^2 + 24x + 9$
 g $49 + 28x + 4x^2$ h $25 + 30x + 9x^2$
 i $4x^2 - 12x + 9$ j $9x^2 - 6x + 1$
 k $16x^2 - 40x + 25$ l $4x^2 - 36x + 81$
- 6 a $9 - 6x + x^2$ b $25 - 10x + x^2$
 c $1 - 2x + x^2$ d $36 - 12x + x^2$

- e $121 - 22x + x^2$ f $16 - 8x + x^2$
 g $49 - 14x + x^2$ h $144 - 24x + x^2$
 i $64 - 32x + 4x^2$ j $4 - 12x + 9x^2$
 k $81 - 36x + 4x^2$ l $100 - 80x + 16x^2$
- 7 a $x + 12$
 b $x^2 + 24x + 144$
 c i $196m^2$ ii $289m^2$
- 8 a $10 - x$
 b $x^2 - 20x + 100$
 c i $64cm^2$ ii $16cm^2$
 d $x = 5$
- 9 a $20 - 2x$
 b $(20 - 2x)(20 - 2x) = 400 - 80x + 4x^2$
 c $196cm^2$
 d $588cm^3$
- 10 a $a^2 - b^2$
 b i $(a - b)^2 = a^2 - 2ab + b^2$
 ii $b(a - b) = ab - b^2$ iii $b(a - b) = ab - b^2$
 c Yes, $a^2 - 2ab + b^2 + ab - b^2 + ab - b^2 = a^2 - b^2$
- 11 a $a + b$ b $(a + b)(a + b) = a^2 + 2ab + b^2$
 c $a - b$ d $(a - b)(a - b) = a^2 - 2ab + b^2$
 e $4ab$ f ab so, yes, four courts' area is $4ab$

9D

Now you try

Example 8

- a $x^2 - 25$ b $x^2 - 225$

Example 9

$144x^2 - 25y^2$

Exercise 9D

- 1 Because $-3x + 3x = 0$
- 2 a Single b Difference c Difference
 d Single
- 3 a $+4x - 16, x^2 - 16$
 b $+2x - 2x - 1, 4x^2 - 1$
- 4 a $x^2 - 1$ b $x^2 - 9$ c $x^2 - 64$
 d $x^2 - 16$ e $x^2 - 144$ f $x^2 - 121$
 g $x^2 - 81$ h $x^2 - 25$ i $x^2 - 36$
 j $25 - x^2$ k $4 - x^2$ l $49 - x^2$
- 5 a $9x^2 - 4$ b $25x^2 - 16$
 c $16x^2 - 9$ d $49x^2 - 9y^2$
 e $81x^2 - 25y^2$ f $121x^2 - y^2$
 g $64x^2 - 4y^2$ h $100x^2 - 81y^2$
 i $49x^2 - 25y^2$ j $36x^2 - 121y^2$
 k $64x^2 - 9y^2$ l $81x^2 - 16y^2$
- 6 a 899 b 1599 c 624 d 2499
 e 396 f 391 g 875 h 2484
- 7 a i x^2 ii $x^2 - 4$
 b No, they differ by 4.
- 8 a $x^2 - 1$ b No, area of rectangle is 1 square unit less.
- 9 a i x^2 ii $x + 3$ iii $x - 3$
 b $x^2 - 9$
 c No, $9m^2$ less

9E

Now you try

Example 10

- a $5b$ b $7xy$

Example 11

- a $5(3a + 4)$ b $2x(x - 3)$

Example 12

$$-11a(1+2a)$$

Exercise 9E

- 1 a 4 b 10 c 5 d 6
 2 a x b x c a d $2a$
 e $-2y$ f $-3x$
 3 a i 6 ii $3x$ iii $6x$
 b iii
 4 a $2x$ b $6a$ c 2 d 4
 e 3 f 1 g $3x$ h $3n$
 i $2y$ j $2x$ k $2xy$ l $5ab$
 5 a $7(x+1)$ b $3(x+1)$ c $4(x-1)$ d $5(x-1)$
 e $4(1+2y)$ f $5(2+a)$ g $3(1-3b)$ h $2(3-x)$
 i $3(4a+b)$ j $6(m+n)$ k $2(5x-4y)$ l $4(a-5b)$
 m $x(x+2)$ n $a(a-4)$ o $y(y-7)$ p $x(1-x)$
 q $3p(p+1)$ r $8x(1-x)$ s $4b(b+3)$ t $2y(3-5y)$
 6 a $-4(2x+1)$ b $-2(2x+1)$
 c $-5(2x+y)$ d $-7(a+2b)$
 e $-3(3x+4)$ f $-2(3y+4)$
 g $-5(2x+3y)$ h $-4(m+5n)$
 i $-3x(x+6)$ j $-4x(2x+3)$
 k $-2y(8y+3)$ l $-5a(a+2)$
 7 a 3 b y c a
 d $5x$ e -7 f $-12a$
 8 a $4(x+2)$ b $2(x+3)$
 c $10(x+2)$ d $2(x+7)$
 e $2(2x+3)$ f $2(x+7)$
 9 $4x$
 10 a $t(5-t)$
 b i 0 m ii 6 m iii 4 m
 c 5 s
 11 a 63 b 72 c -20
 d -70 e 69 f 189
 12 a $3(a^2+3a+4)$ b $z(5z-10+y)$
 c $x(x-2y+xy)$ d $2b(2y-1+3b)$
 e $-4y(3x+2z+5xz)$ f $ab(3+4b+6a)$
 13 a $(x+3)(4+x)$ b $(x+1)(3+x)$
 c $(m-3)(7+m)$ d $(x-7)(x+2)$
 e $(a+4)(8-a)$ f $(x+1)(5-x)$
 g $(y+3)(y-2)$ h $(x+2)(a-x)$
 i $(2t+5)(t+3)$ j $(5m-2)(m+4)$
 k $(4y-1)(y-1)$ l $(7-3x)(1+x)$

Progress quiz

- 1 a $8x-6y$ b $7ab^2-ab$ c $20a^2b$ d $\frac{y}{3}$
 2 a $3x-12$ b $6y^2+10y$ c $3-6x$
 3 a $x^2+10x+24$ b x^2+x-6
 c $2x^2+5x-12$ d $6x^2-19x+10$
 4 a $x^2+12x+36$ b $x^2-16x+64$
 c $9x^2+42x+49$ d $25-10x+x^2$
 5 a $(2x^2-5x-3)m^2$ b $(9x^2-6x+1)m^2$
 6 a x^2-100 b x^2-1 c $9x^2-4$ d $16x^2-25y^2$
 7 $2x+2$
 8 a 4 b $3a$ c $5ab$ d $3x$
 9 a $6(x+2)$ b $5(3y-4)$ c $4a(2b+5)$
 d $2x(2x-1)$ e $-5(2x+1)$ f $-2x(2x+5)$
 10 a $2(4x+3)$ b $6(x+2)$

9F _____

Now you try**Example 13**

a $-\frac{b}{2}$ b $-(x+7)$ or $-x-7$

Example 14

a $a-6$ b -7

Example 15

a $6a$ b 2

Example 16

a $-\frac{3x}{2}$ b $\frac{2}{15}$

Exercise 9F

- 1 a 2 b $2x$ c $2(x+2)$ d $2(x-1)$
 2 a $\frac{3}{2}$ b $\frac{3}{4}$ c $\frac{2}{7x}$
 d $\frac{4a^2}{5}$ e $\frac{1}{7}$ f $\frac{1}{6x}$
 3 a $\frac{8}{9}$ b $\frac{7}{6}$ c $\frac{3}{2}$
 d $\frac{1}{4}$ e 6 f 1
 4 a $\frac{x}{2}$ b $\frac{x}{2}$ c $-\frac{ab}{3}$ d $\frac{a}{2b}$
 e $x-1$ f $-2(2x+1)$ g $-\frac{1}{3}$ h $\frac{a}{10}$
 i 3 j -2 k $\frac{1}{2}$ l $-\frac{2}{3}$
 m $x-4$ n $2(x-1)$ o $-2(x+2)$ p -1
 5 a $x+2$ b $x-3$ c $x-4$ d $\frac{1}{x+1}$
 e $-\frac{1}{2x+3}$ f $\frac{a}{3a-2}$ g 2 h 7
 i -5 j -2 k 6 l -5
 6 a 1 b $\frac{1}{2}$ c $\frac{6a}{5}$ d $\frac{3}{2a}$
 e $\frac{7xy}{3}$ f $\frac{5x}{6}$ g 4 h 5
 i $\frac{9}{2}$ j $\frac{x+1}{4}$ k 1 l $\frac{x+6}{2(x+7)}$
 7 a $\frac{7x}{6}$ b $\frac{2x}{3}$ c $-\frac{21}{8}$ d $-\frac{a^2}{2}$
 e 6 f $\frac{4}{3}$ g 11 h $-\frac{3}{2}$
 i $\frac{-(2x-4)}{2(2x-7)} = \frac{-x+2}{2x-7}$
 8 a $x+1$ b $-(x+2)$ c $\frac{3}{2}$ d $x(x+2)$
 9 a 4 b 5 c -18 d 15
 e -34 f 14
 10 a $x+3$ b $2x-1$ c $-5(x-3)$ d $\frac{-1}{3(x-4)}$
 11 a -1 b -1 c $-\frac{4}{3}$ d 2
 e $-\frac{1}{x-2}$ f $-4(x-6)$

9G _____**Now you try****Example 17**

a $\frac{7a}{10}$ b $\frac{5x}{24}$

Example 18

$$\frac{7x - 17}{12}$$

Exercise 9G

- 1 a 24 b 15 c 143 d 36
 2 a $\frac{5}{6}$ b $\frac{17}{20}$ c $\frac{13}{8}$ d $\frac{7}{10}$
 e $-\frac{2}{15}$ f $\frac{1}{12}$
 3 a $4x$ b $21x$ c 3 d 2 e 8
 f 90
 4 a $\frac{3x}{12} + \frac{8x}{12} = \frac{11x}{12}$
 b $\frac{25x}{35} - \frac{14x}{35} = \frac{11x}{35}$
 5 a 15 b 14 c 8 d 6 e 10
 6 a $\frac{9x}{14}$ b $\frac{2x}{5}$ c $\frac{x}{8}$ d $\frac{14x}{45}$
 e $\frac{y}{56}$ f $\frac{13a}{22}$ g $\frac{2b}{9}$ h $\frac{m}{6}$
 i $\frac{11m}{12}$ j $\frac{15a}{28}$ k $\frac{x}{2}$ l $-\frac{20p}{63}$
 m $-\frac{5b}{18}$ n $\frac{61y}{40}$ o $\frac{13x}{35}$ p $\frac{5x}{12}$
 7 a $\frac{7x+11}{10}$ b $\frac{7x}{12}$ c $\frac{15a-51}{56}$ d $\frac{11y+9}{30}$
 e $\frac{13m+28}{40}$ f $\frac{5x-13}{24}$ g $\frac{11b-6}{24}$ h $\frac{7x}{6}$
 i $\frac{7y-8}{14}$ j $\frac{5t-4}{16}$ k $\frac{34-10x}{21}$ l $\frac{8m-9}{12}$
 8 a $\frac{4x}{8} + \frac{6x}{8} = \frac{10x}{8} = \frac{5x}{4}$
 b $\frac{2x}{4} + \frac{3x}{4} = \frac{5x}{4}$
 c Using denominator 8 does not give answer in simplified form and requires extra steps. Preferable to use actual LCD.
 9 a Didn't make a common denominator and subtracted denominators, $\frac{7x}{15}$
 b Didn't use brackets: $2(x+1) = 2x+2, \frac{7x+2}{10}$
 10 a $\frac{11}{2x}$ b $\frac{1}{3x}$ c $-\frac{3}{4x}$ d $\frac{14}{9x}$
 11 a $-\frac{43x}{30}$ b $\frac{5x}{12}$ c $\frac{13x}{24}$ d $\frac{43x-5}{60}$
 e $\frac{23x-35}{42}$ f $\frac{29x+28}{40}$
 12 a $\frac{x}{3}$ b $\frac{x}{8}$ c $\frac{x}{2}$ d $\frac{x}{5}$
 e $\frac{8x}{9}$ f $\frac{x}{4}$
- Maths@Work: Automotive technology**
- 1 a TSA = $2lw + 2wh + 2hl$
 $= 2(lw + wh + hl)$
 b TSA = $ah + bh + ch + ab$
 c TSA = $2\pi r^2 + 2\pi rh$ d TSA = $\frac{\pi d^2}{2} + \pi dh$
 TSA = $2\pi r(r+h)$ TSA = $\pi d\left(\frac{d}{2} + h\right)$
 2 i c ii a iii b iv d

- 3 a Area of cross-section = $\pi R^2 - \pi r^2$
 $= \pi(R^2 - r^2)$
 $= \pi\left(\frac{D^2}{2^2} - \frac{d^2}{2^2}\right)$
 $= \frac{\pi}{4}(D^2 - d^2)$
 $= \frac{\pi}{4}(D+d)(D-d)$
 b i $76\pi \text{ mm}^2$ ii $31\pi \text{ mm}^2$
 iii $\frac{\pi}{2} \text{ cm}^2$ iv $3\pi \text{ cm}^2$

4 a

Pipe material	Area of cross-section in cm^2	Length in cm	Weight in g	Weight in kg
Poly pipe a	3.77	100	360.03	0.36
Poly pipe b	11.50	100	1098.08	1.10
Poly pipe c	141.37	100	13500.99	13.50
Copper pipe a	0.35	100	308.94	0.31
Copper pipe b	0.31	100	273.84	0.27
Copper pipe c	1.54	100	1376.21	1.38
Steel pipe a	2.89	100	2268.86	2.27
Steel pipe b	8.64	100	6781.91	6.78
Steel pipe c	25.13	100	19729.20	19.73

- b Copper pipe c = 1.38 kg/m; steel pipe b = 6.78 kg/m
 Steel pipe b is 5.4 kg/m heavier than copper pipe c.
 c 3.5 m of poly pipe a = 1.26 kg; 3.5 m of steel pipe a = 7.94 kg
 3.5 m of steel pipe a is 6.68 kg heavier than 3.5 m of poly pipe a.
 d 2.75 m of poly pipe c = 37.13 kg; 5 m of steel pipe c = 98.65 kg.
 5 m of steel pipe c is 61.52 kg heavier than 2.75 m of poly pipe c.

Puzzles and games

- 1 RECIPROCAL
 2 a $4x^2 - 80x + 400$ b $x = 5$
 3 a n^2 b $n(n+1)$ c $\frac{1}{2}n(n+1)$
 4 a $\frac{x+10}{12}$ b $\frac{-11x-2}{15}$
 5 a 48, 49 b 33, 35 c 12, 15
 6 Ryan

Short-answer questions

- 1 a $6x^2$ b $-18ab^2$ c $\frac{b}{2}$ d $-4x$
 2 a $3x - 12$ b $-2x - 12$ c $-x^2 + x$ d $-8x^2 + 12x$
 3 a $7x - 1$ b $5ab$ c $-3a^2b$ d $8x^2 - xy$
 4 a $x^2 + x - 12$ b $x^2 - 9x + 14$
 c $6x^2 - 5x - 6$ d $3x^2 + x - 4$
 5 a $x^2 + 6x + 9$ b $x^2 - 8x + 16$
 c $9x^2 - 12x + 4$ d $x^2 - 25$
 e $49 - x^2$ f $121x^2 - 16$
 6 a $4(a+3b)$ b $-3(1+3x)$
 c $x(x+1)$ d $3x(2-3x)$
 e $-5xy(x+2)$ f $11ab(a-3)$
 7 a $\frac{x-1}{2}$ b $x+1$ c $x+4$ d $\frac{-(x+3)}{2}$ e $\frac{2}{3}$
 f $2(x-1)$

- 8 a $\frac{1}{4}$ b $\frac{a}{2}$ c $\frac{x-4}{2}$
 d $\frac{2a}{3}$ e 4 f $\frac{2}{5}$
 9 a $\frac{11x}{12}$ b $-\frac{x}{24}$ c $\frac{a}{4}$
 d $\frac{5x-2}{6}$ e $\frac{10x-5}{12}$ f $\frac{7x+5}{24}$

Multiple-choice questions

- 1 E 2 C 3 B 4 B 5 C 6 A
 7 E 8 A 9 E 10 E

Extended-response questions

- 1 a $(x+3)$ m
 b i No change
 ii (x^2-1) m², 1 square metre less in area
 c i 3 m² ii $x=4$
 2 a 400 m²
 b i $L = W = (20+2x)$ m ii $(4x^2+80x+400)$ m²
 c $4x(x+20)$ m²
 d $x=5$

Chapter 10

Warm-up quiz

- 1 a 0.1 b 0.25 c 0.3 d 0.85 e 0.237
 2 a $\frac{1}{2}$ b $\frac{1}{3}$ c $\frac{2}{3}$ d 1 e 0
 f $\frac{1}{12}$ g $\frac{1}{2}$ h $\frac{18}{29}$ i $\frac{2}{3}$ j $\frac{2}{7}$
 3 a 1, 2, 3, 4, 5 or 6
 b i 3 ii 2 iii 3 iv 5 v 5 vi 3
 4 a 5 b 7 c $\frac{6}{3}$ d 7 e 4 f 6
 5 a 8 b 20 c $\frac{3}{20}$
 6 a 9
 b 6
 c 5
 d 5
 e 12
 f i $\frac{2}{9}$ ii $\frac{7}{9}$ iii $\frac{5}{9}$

10A

Now you try

Example 1

- a {1, 2, 3} b $\frac{1}{3}$ c $\frac{1}{2}$ d $\frac{1}{2}$ e $\frac{5}{6}$

Example 2

- a $\frac{1}{10}$ b $\frac{7}{10}$ c $\frac{2}{5}$ d $\frac{3}{5}$
 e $\frac{9}{10}$ f $\frac{1}{2}$

Exercise 10A

- 1 a sample space b event c probability
 d impossible, certain e even
 f complement
 2 a i $\frac{1}{4}$ ii 0.25 iii 25%

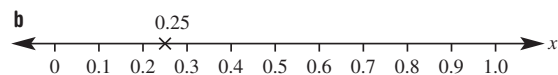

3

	Percentage	Decimal	Fraction	Number line
a	50%	0.5	$\frac{1}{2}$	
b	25%	0.25	$\frac{1}{4}$	
c	75%	0.75	$\frac{3}{4}$	
d	20%	0.2	$\frac{1}{5}$	

- 4 0.15, $\frac{2}{9}$, 1 in 4, 0.28, $\frac{1}{3}$, $\frac{2}{5}$, $\frac{3}{7}$, 2 in 3, 0.7, 0.9

- 5 a i {1, 2, 3, 4, 5, 6, 7} ii $\frac{1}{7}$ iii $\frac{6}{7}$ iv $\frac{2}{7}$ v $\frac{6}{7}$
 b i {2, 6, 7} ii $\frac{1}{2}$ iii $\frac{1}{2}$ iv $\frac{1}{2}$ v 1
 c i {1, 2, 3} ii $\frac{2}{3}$ iii $\frac{1}{3}$ iv $\frac{5}{6}$ v $\frac{5}{6}$
 d i {1, 2, 3} ii $\frac{1}{3}$ iii $\frac{2}{3}$ iv $\frac{2}{3}$ v $\frac{2}{3}$
 e i {1, 2, 3, 4} ii $\frac{1}{7}$ iii $\frac{6}{7}$ iv $\frac{3}{7}$ v $\frac{5}{7}$
 f i {2} ii 1 iii 0 iv 1 v 1
 6 a $\frac{1}{2}$ b $\frac{3}{8}$ c $\frac{1}{6}$ d $\frac{1}{4}$ e 1 f 0
 7 a $\frac{1}{2}$ b $\frac{5}{8}$ c $\frac{5}{6}$ d $\frac{3}{4}$ e 0 f 1
 8 a $\frac{1}{8}$ b $\frac{7}{8}$
 9 a $\frac{1}{8}$ b $\frac{1}{4}$ c $\frac{3}{8}$ d $\frac{3}{8}$ e $\frac{5}{8}$
 f 1 g 0 h $\frac{1}{4}$ i $\frac{3}{4}$ j $\frac{3}{4}$
 10 a {Hayley, Alisa, Rocco, Stuart}
 b i $\frac{1}{4}$ ii $\frac{1}{2}$ iii $\frac{1}{2}$
 11 a $\frac{1}{52}$ b $\frac{1}{13}$ c $\frac{1}{26}$ d $\frac{1}{2}$
 e $\frac{2}{13}$ f $\frac{12}{13}$ g $\frac{23}{26}$ h $\frac{25}{26}$
 12 a $\frac{1}{6}$ b $\frac{1}{6}$ c $\frac{5}{6}$ d $\frac{1}{3}$ e $\frac{2}{3}$ f 1
 g $\frac{1}{3}$ h $\frac{1}{2}$ i $\frac{5}{6}$
 13 a $\frac{2}{11}$ b $\frac{9}{11}$ c $\frac{4}{11}$ d $\frac{7}{11}$
 e $\frac{7}{11}$ f $\frac{3}{11}$ g $\frac{7}{11}$ h $\frac{4}{11}$
 14 a 31 min
 b $\frac{3}{31}$
 c i $\frac{4}{31}$ ii $\frac{4}{31}$ iii $\frac{20}{31}$ iv $\frac{5}{31}$
 v $\frac{8}{31}$ vi $\frac{11}{31}$

10B

Now you try

Example 3

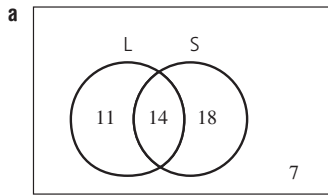

- b i 43 ii 25 iii 18
 c i $\frac{7}{25}$ ii $\frac{7}{50}$ iii $\frac{11}{50}$

Example 4

	Natural	Not Natural	Total
Artificial	20	25	45
Not artificial	45	10	55
Total	65	35	100

- b i 55 ii 10
 c i $\frac{13}{20}$ ii $\frac{9}{20}$ iii $\frac{9}{10}$

Exercise 10B

- 1 a 26
 b i 10 ii 14 iii 5 iv 9
 v 4 vi 7 vii 19
 c i 12 ii 17
 2 a 22 b 12 c 10 d 39 e 13
 f 1
 3 a B b D c A d C

4 a

	A	Not A	Total
B	7	8	15
Not B	3	1	4
Total	10	9	19

b

	A	Not A	Total
B	2	5	7
Not B	9	4	13
Total	11	9	20

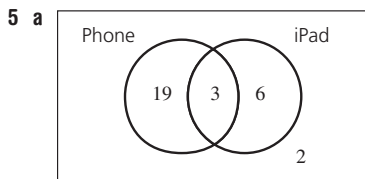

- b i 28 ii 21 iii 6
 c i $\frac{1}{10}$ ii $\frac{1}{15}$ iii $\frac{19}{30}$
 6 i Not A: diagram T ii A or B: diagram R
 iii A and B: diagram U iv B: diagram P
 v B only: diagram Q vi Neither A nor B: diagram S
 7 a i $\frac{2}{5}$ ii $\frac{1}{3}$ iii $\frac{7}{15}$ iv $\frac{1}{15}$
 v $\frac{13}{15}$ vi $\frac{2}{15}$
 b i $\frac{3}{7}$ ii $\frac{12}{35}$ iii $\frac{13}{35}$ iv $\frac{3}{35}$
 v $\frac{34}{35}$ vi $\frac{1}{35}$

8 a

	Cream	Not cream	Total
Ice cream	5	20	25
Not ice cream	16	9	25
Total	21	29	50

- b i 29 ii 9
 c i $\frac{21}{50}$ ii $\frac{8}{25}$ iii $\frac{41}{50}$

9 a

	A	Not A	Total
B	3	1	4
Not B	2	2	4
Total	5	3	8

- i $\frac{5}{8}$ ii $\frac{3}{8}$ iii $\frac{3}{8}$ iv $\frac{3}{4}$ v $\frac{1}{8}$ vi $\frac{1}{4}$

b

	A	Not A	Total
B	11	4	15
Not B	6	5	11
Total	17	9	26

- i $\frac{17}{26}$ ii $\frac{9}{26}$ iii $\frac{11}{26}$ iv $\frac{21}{26}$ v $\frac{2}{13}$ vi $\frac{5}{26}$

10 a

	A	Not A	Total
B	2	6	8
Not B	3	1	4
Total	5	7	12

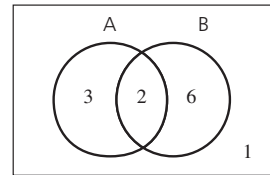

b

	A	Not A	Total
B	3	4	7
Not B	9	4	13
Total	12	8	20

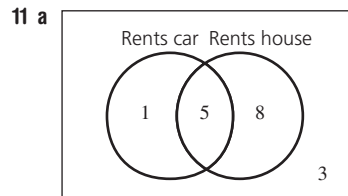
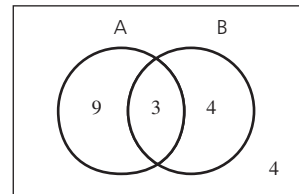

- b 5 c $\frac{1}{17}$

12 a

	Tank water	No tank water	Total
Tap water	12	36	48
No tap water	11	41	52
Total	23	77	100

- b 12 c $\frac{9}{25}$ d $\frac{59}{100}$

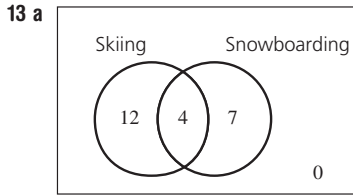

- b 23 c $\frac{11}{23}$ d $\frac{4}{16} = \frac{1}{4}$ e $\frac{4}{11}$

- 14 a $\frac{3}{10}$ b $\frac{1}{3}$

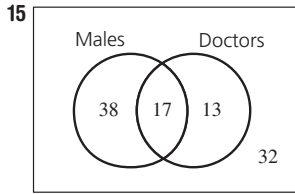

- a 32 b 45 c 70 d 38 e 13
f 13 g 62

10C

Now you try

Example 5

a

	1	2	3	4	5	6	7	8
H	H1	H2	H3	H4	H5	H6	H7	H8
T	T1	T2	T3	T4	T5	T6	T7	T8

- b 16 c $\frac{1}{16}$ d $\frac{3}{16}$

Example 6

a

	3	5	6
3	×	(3, 5)	(3, 6)
5	(5, 3)	×	(5, 6)
6	(6, 3)	(6, 5)	×

b $\frac{1}{6}$ c $\frac{1}{3}$

Exercise 10C

1

	B	Y	E
H	HB	HY	HE
I	IB	IY	IE

2 a

	1	2	3	4
H	H1	H2	H3	H4
T	T1	T2	T3	T4

- b 8 outcomes in the sample space c $\frac{1}{8}$ d $\frac{1}{8}$

- 3 a 10 b H2, H4, T2, T4 c $\frac{2}{5}$

- d T1, T3, T5 e $\frac{3}{10}$

- 4 a $\frac{1}{4}$ b HH, TT c $\frac{1}{2}$

5 a

	1	2	3	4	5	6
H	H1	H2	H3	H4	H5	H6
T	T1	T2	T3	T4	T5	T6

- b 12 c $\frac{1}{12}$ d $\frac{1}{4}$

6 a

	R	I	D	E
L	LR	LI	LD	LE
I	IR	II	ID	IE
N	NR	NI	ND	NE
E	ER	EI	ED	EE

b 16

- c $\frac{1}{16}$ d $\frac{1}{16}$ e $\frac{1}{4}$
f $\frac{1}{4}$ g $\frac{1}{8}$

7 a

	R	P	B
R	RR	RP	RB
P	PR	PP	PB
G	GR	GP	GB
B	BR	BP	BB

- b $\frac{1}{12}$ c $\frac{1}{12}$ d $\frac{1}{6}$ e $\frac{1}{4}$

8 a

Sum	1	2	3	4	5	6
1	2	3	4	5	6	7
2	3	4	5	6	7	8
3	4	5	6	7	8	9
4	5	6	7	8	9	10
5	6	7	8	9	10	11
6	7	8	9	10	11	12

- 36 outcomes b $\frac{1}{9}$

- c $\frac{1}{2}$ d 7 e 2 and 12

9 a

	Y	W	B	B	B
W	WY	WW	WB	WB	WB
O	OY	OW	OB	OB	OB
O	OY	OW	OB	OB	OB

- b $\frac{2}{15}$ c $\frac{1}{15}$ d $\frac{2}{15}$
e $\frac{1}{5}$ f $\frac{1}{15}$

10 a

	D	O	G
D	X	(0, D)	(G, D)
O	(D, 0)	X	(G, 0)
G	(D, G)	(0, G)	X

- b $\frac{1}{6}$ c $\frac{2}{3}$

11 a

		1st			
		1	2	3	4
2nd	1	X	(2, 1)	(3, 1)	(4, 1)
	2	(1, 2)	X	(3, 2)	(4, 2)
	3	(1, 3)	(2, 3)	X	(4, 3)
	4	(1, 4)	(2, 4)	(3, 4)	X

- b i $\frac{1}{12}$ ii $\frac{1}{12}$
c i $\frac{1}{6}$ ii $\frac{5}{6}$ iii $\frac{1}{6}$ iv $\frac{1}{2}$

- 12 a $\frac{1}{8}$ b $\frac{1}{3}$

Now you try

Example 7

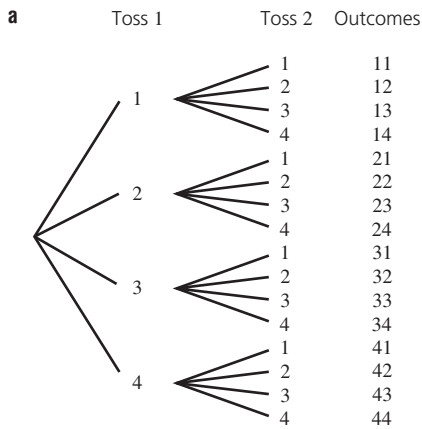

b 16

c i $\frac{1}{16}$

ii $\frac{3}{8}$

iii $\frac{15}{16}$

Example 8

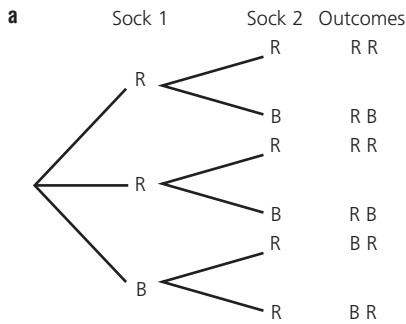

b i $\frac{1}{3}$

ii $\frac{2}{3}$

iii 1

Exercise 10D

1 **a** A **b** B

2 **a** i replacement ii 3

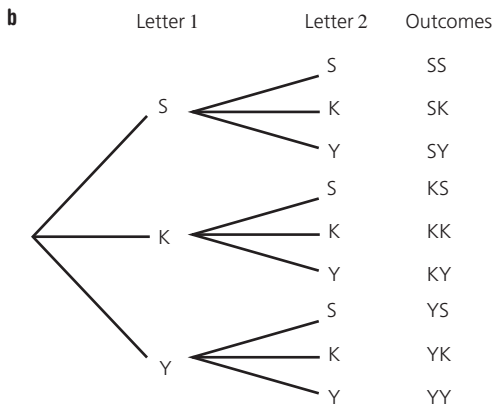

3 **a** i Without replacement ii 2

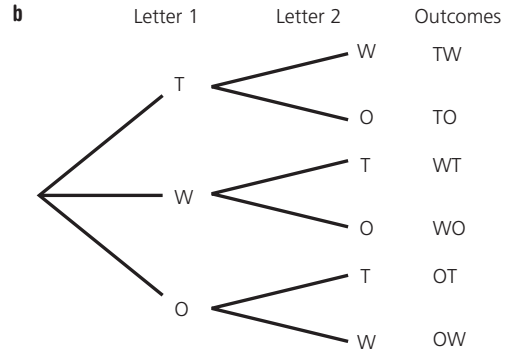

4 **a**

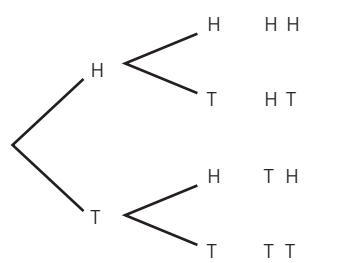

b 4

c i $\frac{1}{4}$

ii $\frac{1}{2}$

iii $\frac{3}{4}$

iv $\frac{3}{4}$

5 **a**

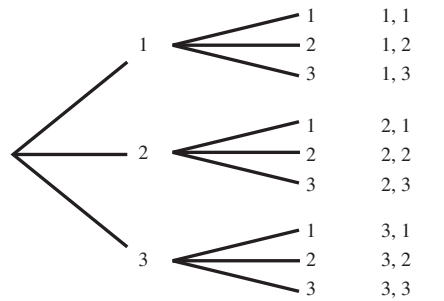

b $\frac{1}{9}$

c $\frac{1}{9}$

d $\frac{2}{9}$

e $\frac{1}{3}$

f $\frac{1}{3}$

6 **a**

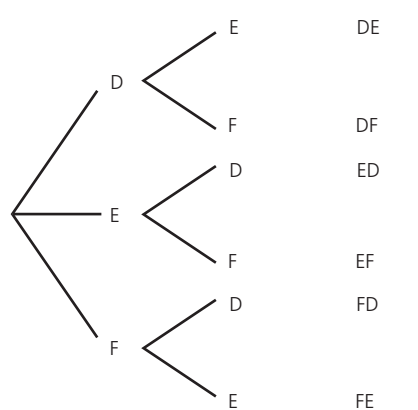

b i $\frac{1}{3}$

ii $\frac{2}{3}$

iii 1

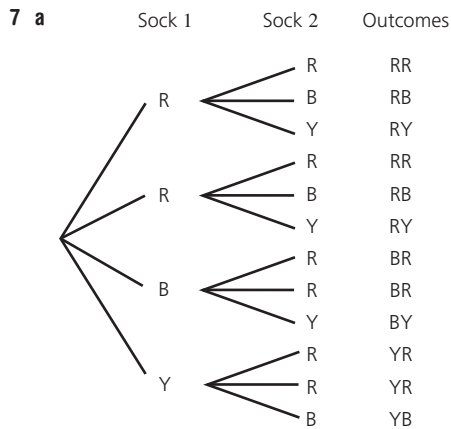

- b** i $\frac{1}{3}$ ii $\frac{1}{6}$ iii $\frac{1}{6}$ iv $\frac{5}{6}$

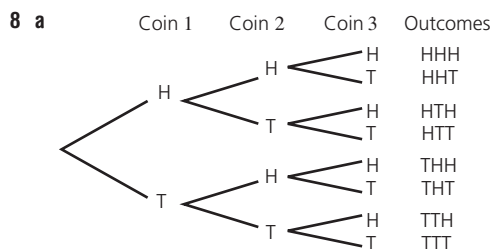

- b** $\frac{1}{8}$ **c** $\frac{1}{8}$ **d** $\frac{3}{8}$

e Getting exactly 2 tails

- 9 a** $\frac{3}{5}$ **b** $\frac{2}{5}$ **c** $\frac{7}{10}$

- 10 a** $\frac{1}{9}$ **b** $\frac{1}{9}$ **c** $\frac{7}{18}$ **d** $\frac{7}{18}$ **e** $\frac{1}{2}$ **f** 0

- g** $\frac{1}{6}$ **h** $\frac{2}{3}$ **i** $\frac{1}{9}$ **j** $\frac{17}{18}$

10E

Now you try

Example 9

- a** $\frac{4}{5}$ or 0.8 **b** 40

Example 10

- a** $\frac{5}{24}$ **b** 200

Exercise 10E

- 1 a** Experimental **b** Theoretical **c** Theoretical
d Experimental **e** Expected
- 2 a** $\frac{9}{10}$ **b** $\frac{4}{5}$ **c** $\frac{5}{9}$
- 3 a** $\frac{2}{5}$ **b** 40
- 4 a** 5 **b** 10 **c** 50 **d** 4
- 5 a** $\frac{35}{90} = \frac{7}{18}$ **b** 1050
- 6 a** 0.6
b i 60 ii 120 iii 360
- 7 a** $\frac{7}{8}$
b i 350 ii 4375 iii 35
- 8 a** $\frac{1}{15}$ **b** $\frac{2}{5}$ **c** $\frac{11}{60}$

9 a B: $\frac{5}{20} = 0.25$ C: $\frac{30}{100} = 0.3$

b C as it is a larger sample size

10 0.41, from the 100 throws as the more times an experiment is carried out the closer the experimental probability becomes to the actual/theoretical probability

- 11 a** 20 **b** 40 **c** 60 **d** 40

12 a 20

- b** i $\frac{1}{4}$ ii $\frac{7}{20}$

- c** i 25 ii 20 iii 45

- 13 a** i 0.52 ii 0.48 iii 0.78

b 78

c $\frac{1}{2}, \frac{1}{4}, \frac{1}{4}$

d

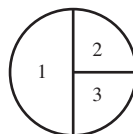

14 a $\frac{\text{Shaded area}}{\text{Total area}} = 0.225$, \therefore 100 shots \approx 23

b $\frac{1}{10} \times 100 = 10$

c $\frac{150 - 32}{150} \times 100 \approx 79$

d $\frac{225\pi - 25\pi}{225\pi} \times 100 \approx 89$

10F

Now you try

Example 11

- a** i 5 ii 4 iii 7 iv 6
b i 0.75 ii 0.5 iii 0 iv 9

Example 12

- a** 87 **b** 97

Exercise 10F

- 1 a** mean
b i 7.8 ii 9.9
- 2 a** common (or frequent)
b i 2 ii 10
- 3 a** middle
b i 5 ii 8
- 4 a** range
b i 21 ii 22
- 5 a** outlier
b i 36 ii 3

6

	Mean	Median	Mode	Range
a	6	7	8	7
b	8	6	5, 10	13
c	6	6	2	10
d	11	12	none	13
e	4	3.5	2.1	6.2
f	5	4.5	none	9.7
g	3	3.5	-3	12
h	0	2	3	11

- 7 a** Outlier = 33, mean = 12, median = 7.5
b Outlier = 2, mean = 35.2, median = 42
c Outlier = -1.1, mean = 1.075, median = 1.4
d Outlier = -4, mean = -49, median = -59

- 8 a** Yes **b** No **c** No **d** Yes

- 9 a** 12 **b** 5.5 **c** 6 **d** Bimodal; 4, 7

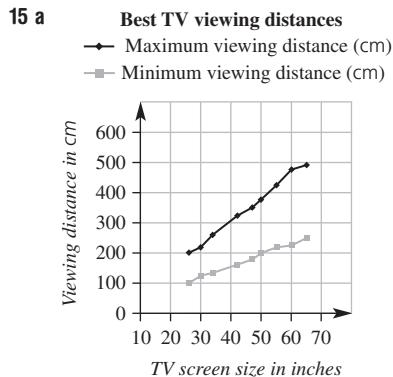

- b** 26 inch, 30 inch, 34 inch
c 42 inch, 47 inch, 50 inch, 55 inch, 60 inch, 65 inch

10H
Now you try

Example 14

a

Stem	Leaf
0	9
1	1 3 6
2	1 4 6 9 9
3	4 5 7
4	2 6
5	0 2

3|5 means 35

- b** 29 **c** 29 **d** Almost symmetrical

Example 15

a

Class A	Class B
	0 3
9 9 7 5	1 1 2 3 4 6 8
9 4 1	2 0
6 1 3	

2|4 means 24 pages

- b** The number of pages read by class A is between 15 and 36 while for class B it is between 11 and 20 except for a lower value of 3. In general class A is reading more.

Exercise 10H

- 1 a** 3.5, 3.7, 4.1, 4.3, 4.8 **b** 52, 60, 61, 67, 73, 75
2 a 9
b i 8 min **ii** 35 min
c 21 min
d 21 min
3 a 26
b i 0 mm **ii** 6 mm
c i 21 mm **ii** 24 mm
d i 8 mm **ii** 15 mm
e Skewed
f Symmetrical

4 a i

Stem	Leaf
1	9 9
2	3 4 6 6 8 8 8
3	2 2 3 5
4	1
5	4

2|3 means 23

- ii** 28 **iii** 28 **iv** Skewed

b i

Stem	Leaf
1	5 5
2	1 3 3 3 6
3	0 1 1 3 4 5 5 7 9
4	2 2 5 5 5 8
5	0 0 1

4|2 means 42

- ii** 35 **iii** 23, 45 **iv** Almost symmetrical

c i

Stem	Leaf
32	0
33	3 7 8
34	3 4 5 5 7 8 9
35	2 2 4 5 8
36	1 3 5
37	0

34|3 means 34.3

- ii** 34.85 **iii** 34.5, 35.2 **iv** Almost symmetrical

d i

Stem	Leaf
15	7 8 9 9 9 9
16	1 4 7 7 7
17	3 5 7 7
18	5 5 7 9
19	3 8
20	0 2

17|7 means 177

- ii** 173 **iii** 159 **iv** Skewed

5 a

Stem	Leaf
0	5 6 6 8 8 9
1	0 1 1 2 2 2 4 4 5 6 7
2	0 1 2

1|2 means 12

- b** 9 **c** 12

6 a

Set A	Set B
9 3 2 3	1
8 7 6 5 3 3 0 0	4 0 1 3 4 4 6 7 8 8 9 9
4 4 3	5 1 3

3|2 means 32

- i** Set A has values spread between 32 and 54 while set B has most of its values between 40 and 53 with an outlier at 31.

b i

Set A	Set B
8 7 4 3 0	1 1 1 2 3 6 6 9 9
9 9 7 6 4 1	2 3 5 8 9
6 5 3 1 2	1 5 6
9 9 6 4 3 2 3	3 4 9
7 3 1 4	3 7 8
7 3 2 5	2 3 7
2 1 6	1 2
8 3 8	3 8
1 9	

4|1 means 4.1

- ii** Set A and B are similar. Set A has values between 0.3 and 9.1 and set B has values between 0.1 and 8.8. Both sets have many small numbers and fewer large numbers.

7 a

Collingwood	St Kilda
8 3 6	6 8 8
8 7 2 1 0 7	8
9 9 8 2 0 8	0 0 2 2 3 4 7 8
8 7 5 1 9	0 4
4 3 3 3 10	6 9
9 8 5 11	1 3 7 8
7 12	2 5 6
	13 8
10 6	means 106

- b Collingwood $33\frac{1}{3}\%$ St Kilda $41\frac{2}{3}\%$
 c Collingwood is almost symmetrical data. St Kilda is not symmetrical.
 d Collingwood results seem to be consistent. St Kilda has groups of similar scores and, while less consistent, that team has higher scores.
- 8 a 16.1 s b 2.3 s c Yes, 0.05 s lower

9 a

Battery lifetime	
Brand A	Brand B
3 7	2 3 4
	7 5 6 8 9 9
4 2 8	0 1 3
9 8 7 5 8	
4 4 3 2 1 0 9	0 1 2 3 4
9 9 8 7 6 5 5 9	5 6 8 8
8 3	represents 8.3 hours

- b Brand A, 12; brand B, 8
 c Brand A consistently performs better than brand B.
- 10 a 52 b 17.8
 11 a 48% b 15%
 c In general, birth weights of babies are lower for mothers who smoke.

101 _____

Now you try

Example 16

a

Class interval	Frequency	Percentage frequency
10 –	3	25
20 –	2	$16\frac{2}{3}$
30 –	2	$16\frac{2}{3}$
40 –	2	$16\frac{2}{3}$
50–60	3	25
Total	12	100

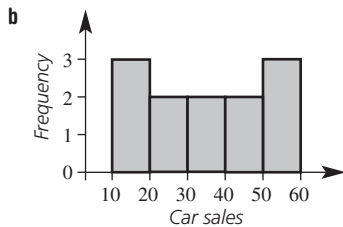

- c 3 d 25%

Exercise 101

- 1 a class interval b frequency
 c histogram d percentage frequency
- 2 a 20 b 20
 3 a 3 b 360 000–370 000

- 4 a 2
 b 20
 c i 30% ii 65%

5 a

Class	Frequency	Percentage frequency
0–	23	46
10–	10	20
20–	6	12
30–	7	14
40–	4	8
	50	100

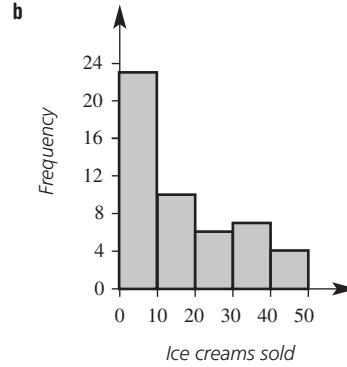

- c i 33 ii 11
 d 34%

6 a

Class	Frequency	Percentage frequency
50–	8	$13\frac{1}{3}$
60–	14	$23\frac{1}{3}$
70–	9	15
80–	25	$41\frac{2}{3}$
90–	4	$6\frac{2}{3}$
	60	100

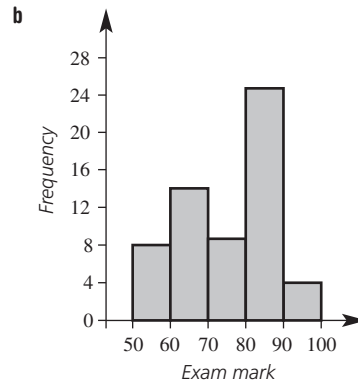

- c i 22 ii $63\frac{1}{3}\%$

7 a

Number of goals	Frequency
0 – 2	1
3 – 5	8
6 – 8	7
9 – 11	7
12 – 14	7
	30

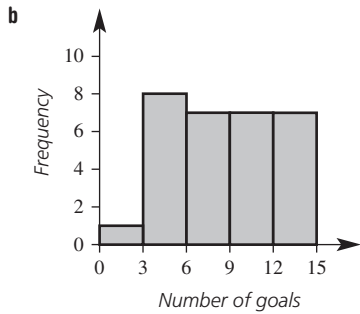

- c** 9 **d** 7
8 a Symmetrical data **b** Skewed data
9 a $a = 15$ $b = 2$ $c = 30$ $d = 40$ $e = 20$ $f = 100$
b $a = 50$ $b = 28$ $c = 12$ $d = 40$ $e = 100$

10 85.5%

- 11 a** **i** 20% **ii** 55% **iii** 80%
iv 75% **v** 50%
b i 30 **ii** 45
c i 2 **ii** 22

12 a Student A

b Make the intervals for their groups of data smaller so that the graph conveys more information.

13 a Minimum wage: \$204; maximum wage: \$940

b i

Weekly wages (\$)	Frequency
200–	2
300–	7
400–	6
500–	6
600–	11
700–	11
800–	5
900–	2
Total	50

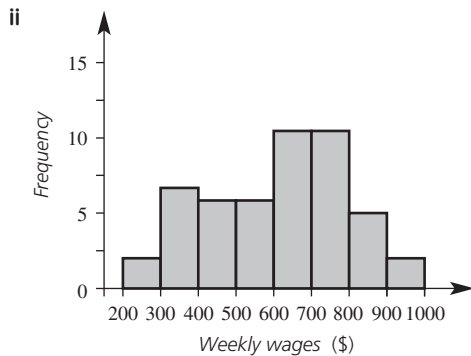

c i

Weekly wages	Frequency
200–	9
400–	12
600–	22
800–	7
Total	50

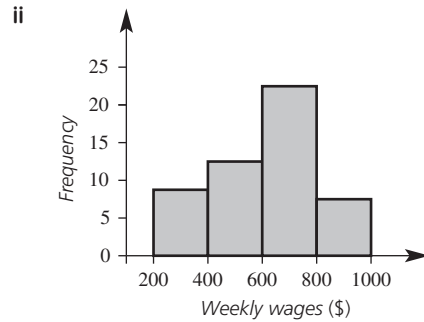

d More intervals shows greater detail. Since first graph has each pair of intervals quite similar, these two graphs are quite similar.

Maths@Work: Personal trainer

- 1 a** 88 bpm **b** 84 bpm
c 98 bpm **d** 119 bpm
2 a Yes **b** No **c** Yes **d** No
e Yes
3 Mean 94.6 bpm, mode 90 bpm, median 93.5 bpm, range 35 bpm
4 Mean 105.8 bpm, mode 98 bpm, median 104.5 bpm, range 59 bpm
The data has a higher mean, median and mode, and is more spread out (range is much higher).
5 Graph should look like the following.

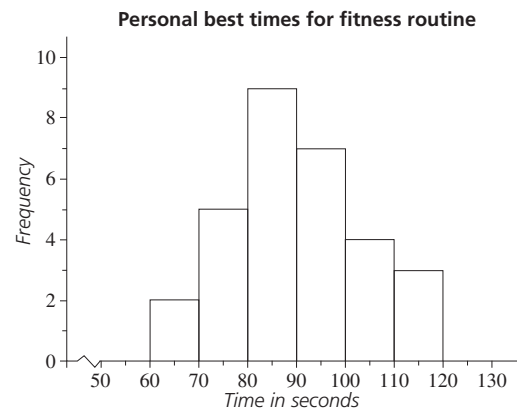

Puzzles and games

- 1** IT'S RANDOM
2 1 – C, 2 – B, 3 – E, 4 – D, 5 – A
3 6 own both cat and a dog
4 2, 3, 4, 8, 8
5 7, 8, 9, 10 and 11

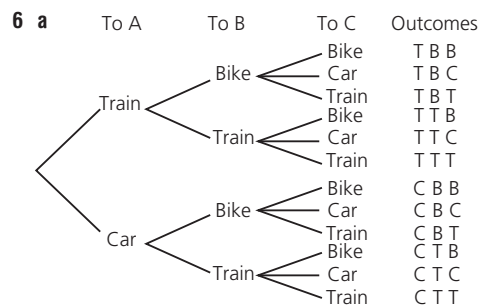

- b** 12 **c** $\frac{1}{4}$

Short-answer questions

1 a $\frac{2}{3}$ b $\frac{5}{9}$ c $\frac{3}{5}$

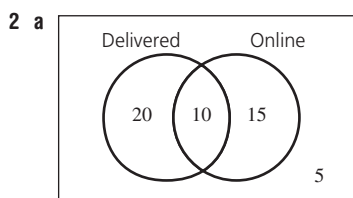

b 15

c i $\frac{1}{5}$ ii $\frac{2}{5}$ iii $\frac{3}{10}$

3 a

	A	Not A	Total
B	9	16	25
Not B	8	12	20
Total	17	28	45

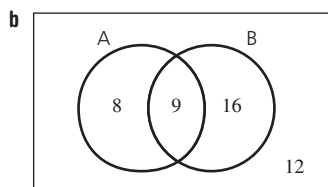

c i $\frac{4}{9}$ ii $\frac{1}{5}$ iii 8 iv 33

4 a 12 outcomes

	1	2	3	4
red	(red, 1)	(red, 2)	(red, 3)	(red, 4)
green	(green, 1)	(green, 2)	(green, 3)	(green, 4)
blue	(blue, 1)	(blue, 2)	(blue, 3)	(blue, 4)

b i $\frac{1}{6}$ ii $\frac{1}{6}$ iii $\frac{2}{3}$

5 a

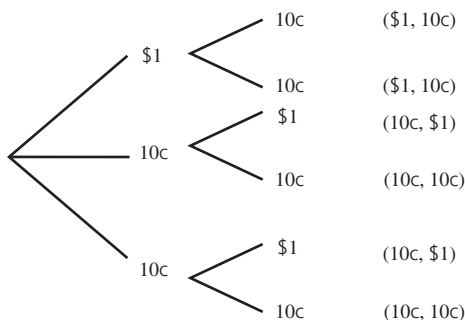

b $\frac{2}{3}$

6 a $\frac{48}{120} = \frac{2}{5}$ b 14

7 a 26 b 26.5 c 23, 31 d 18

8 a

Employee 1	Employee 2
9 1	7 7
5 3 1	2 0 4 8 9
9 8 6 5 5 4	3 2 7 7 8
6 5 0	4 0 1 2 5 8
3 1	5
2 4	means 24

b i Employee 1: 36, employee 2: 37
ii Employee 1: 36, employee 2: 33

c Employee 1; they have a higher mean and more sales at the high end.

d Employee 1 symmetrical, employee 2 skewed

9 a

Class interval	Frequency	Percentage frequency
120–	1	4
130–	3	12
140–	4	16
150–	8	32
160–	7	28
170–	2	8
Total	25	100

b

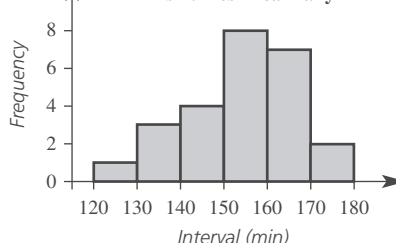

c i 4 ii 60%

10 a Mean = \$760 000

Median = \$590 000

b The median is better because the mean has been inflated by the outlier of \$2 900 000.

Multiple-choice questions

1 B 2 A

3 i A ii B iii D iv C

4 B 5 D

6 i B ii C

7 E 8 C

Extended-response questions

1 a i

		1st spin				
		1	2	3	4	5
2nd spin	1	(1, 1)	(2, 1)	(3, 1)	(4, 1)	(5, 1)
	2	(1, 2)	(2, 2)	(3, 2)	(4, 2)	(5, 2)
	3	(1, 3)	(2, 3)	(3, 3)	(4, 3)	(5, 3)
	4	(1, 4)	(2, 4)	(3, 4)	(4, 4)	(5, 4)
	5	(1, 5)	(2, 5)	(3, 5)	(4, 5)	(5, 5)

ii $\frac{12}{25}$ iii $\frac{4}{25}$ iv 24 v \$68

b i

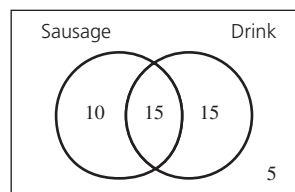

ii 5

iii 10 iv $\frac{1}{3}$ v $\frac{4}{9}$

2 a	Airline A	Airline B
	4 4 3 2 2 1 1 0	0 1 2 4 4
	9 8 7 7 6	0* 5 5 6 7 7 8 9
	4 4 4 3 3 3 2 2 1	1 0 0 0 0 1 2 2
	9 9 8 8 7	1* 5 5 8 8 8 9 9
	4 3	2 1 2 2
		2* 5 6
	2	5

1 | 2 means 12 1* | 5 means 15

- b** Yes, 52 min
c i Airline A: 12, airline B: 10.5
ii Airline A: 10.6, airline B: 12.4
d No, the median time is 12 min so half the flights have less than 12 min delay.

Semester review 2

Measurement

Short-answer questions

- 1 a** 22 cm² **b** 12 cm² **c** 25.92 m²
2 a 25.13 m, 50.27 m² **b** 62.83 cm, 314.16 cm²
c 13.19 cm, 13.85 cm²
3 a 54.82 cm² **b** 26 m² **c** 24.57 m² **d** 36 cm²
4 a 220 m² **b** 216 m² **c** 25.45 m²
5 a 12 m³ **b** 42 m³ **c** 100.53 cm³

Multiple-choice questions

- 1** C **2** C **3** D **4** C **5** A

Extended-response question

- a** 12.57 m²
b 77.43 m²
c \$628

Indices

Short-answer questions

- 1 a** $15p^3q^2$ **b** $\frac{a^2b}{2}$ **c** $54x^9y^6$ **d** -2
2 a $3 \times 4^2 = 48$ **b** $\frac{4}{10^3} = 0.004$
3 a 2400 **b** 1 080 000
c 0.0071 **d** 0.0000206
4 a 6.03×10^4 **b** 2.7×10^6
c 4×10^{-3} **d** 7.03×10^{-4}
5 a 3.07×10^{-2} kg **b** 4.24×10^6 kg
c 1.22×10^4 s **d** 7.45×10^{-6} years

Multiple-choice questions

- 1** C **2** B **3** D **4** E **5** C

Extended-response question

- a i** 74 000 000 000 **ii** 7.4×10^{10}
b 1.87×10^{17}
c 8.72×10^{-7}

Geometry

Short-answer questions

- 1 a** 180° **b** 360° **c** 540°
d 900° **e** 1080° **f** 1440°
2 a $x = 70$ **b** $x = 70$ **c** $a = 100, b = 140$
d $a = 70, b = 110$ **e** $x = 100, y = 110$
f $x = 67, y = 98$ **g** $x = 120$
h $a = 135$
3 a Yes, RHS **b** $\triangle ABC \equiv \triangle DEF$
c AB
4 a SAS **b** 2
5 a AAA **b** 2.4

Multiple-choice questions

- 1** C **2** B **3** A **4** E **5** B

Extended-response question

- a** AAA **b** 6 m **c** $\frac{5}{3} = 1.\dot{6}$ **d** 7.5 m
e 3.75 m

Algebraic techniques

Short-answer questions

- 1 a** $-3x - 6$ **b** $x - x^2$ **c** $x^2 - 1$
d $x^2 - 8x + 16$ **e** $25x^2 - 4$
f $9x^2 - 24x + 16$ **g** $8x^2 + 10x - 3$
h $2x + 3$ **i** $4 - 4x + x^2$
2 a $-6x^2y$ **b** $42a^2b^2$ **c** $\frac{a}{2}$ **d** $\frac{-6x}{y}$
e $\frac{a}{b}$ **f** $\frac{1}{2y}$
3 a $x^2 - 9$ **b** $x^2 + 4x + 4$
c $6x^2 - 17x + 12$
4 a $3(x - 4)$ **b** $-7(x + 2)$
c $x(5x + 2)$ **d** $7x(2x - 3)$
5 a $\frac{3x}{2}$ **b** $\frac{3}{4}$ **c** 4 **d** -x
e $\frac{3}{2}$ **f** $\frac{9a}{x}$
6 a $\frac{x}{12}$ **b** $\frac{53x}{20}$ **c** $\frac{7x + 5}{10}$ **d** $\frac{11x + 7}{15}$

Multiple-choice questions

- 1** E **2** E **3** A **4** B **5** D

Extended-response question

- a** $10 - 2x$ and $8 - 2x$
b $(10 - 2x)(8 - 2x) = 80 - 36x + 4x^2$
c 48 m²

Statistics and probability

Short-answer questions

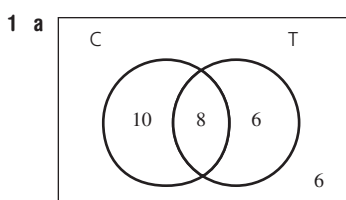

- b i** 24 **ii** 16

c i $\frac{1}{5}$ ii $\frac{1}{3}$

2 a

	1	2	3	4
H	H1	H2	H3	H4
T	T1	T2	T3	T4

b 8 c $\frac{1}{8}$ d $\frac{1}{4}$

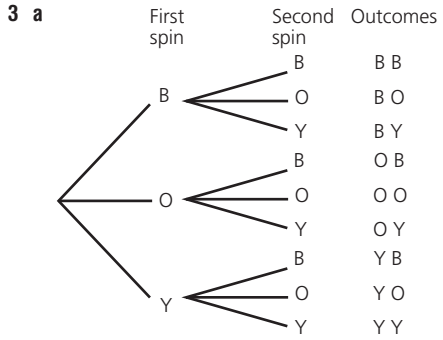

b $\frac{1}{9}$ c $\frac{1}{3}$ d $\frac{2}{9}$

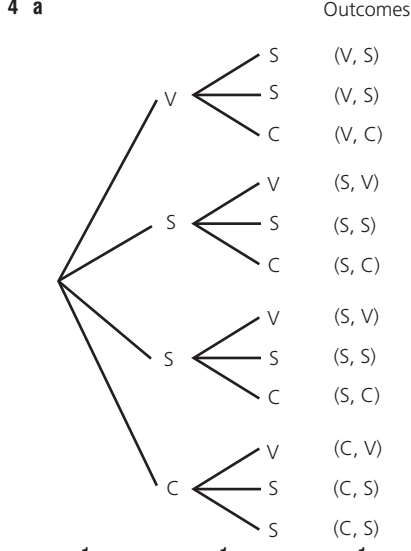

b i $\frac{1}{3}$ ii $\frac{1}{6}$ iii $\frac{1}{2}$

5 a

Stem	Leaf
1	0 1 1 2 3 5 7 8
2	2 5 5 5 6
3	1 2 2

1 | 3 means 13 aces

b Mode = 25, median = 20

c Skewed

6 a

Class interval	Frequency	Percentage frequency
0–	2	6.7
50–	4	13.3
100–	5	16.7
150–	9	30
200–	7	23.3
250–	3	10
Total	30	100



c i 6 ii 60%

Multiple-choice questions

- 1 D
- 2 A
- 3 a C b D
- 4 B
- 5 B

Extended-response question

a

		Red		
		1	2	3
Green	1	(1, 1)	(1, 2)	(1, 3)
	2	(2, 1)	(2, 2)	(2, 3)
	3	(3, 1)	(3, 2)	(3, 3)

- b $\frac{4}{9}$
- c i $\frac{1}{3}$ ii 18
- d i 17 years ii 92