

# CHEMISTRY IN FOCUS

YEAR

12

**Anna Davis**

Anne Disney

Debra Smith

Chemistry In Focus Year 12

2nd Edition

Anna Davis

Anne Disney

Debra Smith

Contributing authors: Veronica Hayes, Rachel Whan  
9780170408998

Publisher: Eleanor Gregory

Project editor: Felicity Clissold

Editor: Scott Vandervalk

Proofreader: Marcia Bascombe

Permissions researcher: Wendy Duncan

Indexer: Don Jordan (Antipodes Indexing)

Text design: Leigh Ashforth (Watershed Design)

Cover design: Chris Starr (MakeWork)

Cover image: iStock.com/ultramarinfo

Production controller: Karen Young

Typeset by: MPS Limited

Any URLs contained in this publication were checked for currency during the production process. Note, however, that the publisher cannot vouch for the ongoing currency of URLs.

© 2018 Cengage Learning Australia Pty Limited

#### Copyright Notice

This Work is copyright. No part of this Work may be reproduced, stored in a retrieval system, or transmitted in any form or by any means without prior written permission of the Publisher. Except as permitted under the *Copriht At 1968*, for example any fair dealing for the purposes of private study, research, criticism or review, subject to certain limitations. These limitations include: Restricting the copying to a maximum of one chapter or 10% of this book, whichever is greater; providing an appropriate notice and warning with the copies of the Work disseminated; taking all reasonable steps to limit access to these copies to people authorised to receive these copies; ensuring you hold the appropriate Licences issued by the Copyright Agency Limited ("CAL"), supply a remuneration notice to CAL and pay any required fees. For details of CAL licences and remuneration notices please contact CAL at Level 11, 66 Goulburn Street, Sydney NSW 2000, Tel: (02) 9394 7600, Fax: (02) 9394 7601  
Email: [info@copyright.com.au](mailto:info@copyright.com.au)  
Website: [www.copyright.com.au](http://www.copyright.com.au)

For product information and technology assistance,  
in Australia call **1300 790 853**;  
in New Zealand call **0800 449 725**

For permission to use material from this text or product, please email  
[aust.permissions@cengage.com](mailto:aust.permissions@cengage.com)

#### National Library of Australia Cataloguing-in-Publication Data

A catalogue record for this book is available from the National Library of Australia.

#### Cengage Learning Australia

Level 7, 80 Dorcas Street  
South Melbourne, Victoria Australia 3205

#### Cengage Learning New Zealand

Unit 4B Rosedale Office Park  
331 Rosedale Road, Albany, North Shore 0632, NZ

For learning solutions, visit [cengage.com.au](http://cengage.com.au)

Printed in China by China Translation & Printing Services.

1 2 3 4 5 6 7 22 21 20 19 18



# CONTENTS

INTRODUCTION . . . . .	viii
AUTHOR TEAM . . . . .	x
AUTHOR ACKNOWLEDGEMENTS . . . . .	x
PUBLISHER ACKNOWLEDGEMENTS . . . . .	x
USING <i>CHEMISTRY IN FOCUS</i> . . . . .	xi
OUTCOME GRID . . . . .	xiii



1

## Working scientifically and depth studies

1

1.1	The nature of chemistry . . . . .	2
1.2	Solving scientific problems – depth studies . . . . .	4
1.3	Designing your investigation . . . . .	7
1.4	Conducting your investigation . . . . .	12
1.5	Analysing data . . . . .	15
1.6	Communicating your understanding . . . . .	18
1.7	Ideas for depth studies . . . . .	21
▶	Chapter summary . . . . .	22

## MODULE FIVE » EQUILIBRIUM AND ACID REACTIONS

23



2

## Qualitative equilibrium

24

2.1	Non-equilibrium systems . . . . .	25
2.2	Reversible reactions . . . . .	28
2.3	Dynamic equilibrium . . . . .	34
2.4	Changes to equilibrium . . . . .	39
▶	Chapter summary . . . . .	50
▶	Chapter review questions . . . . .	51



3

## Calculating the equilibrium constant

53

3.1	Equilibrium constant . . . . .	54
3.2	Measuring equilibrium constants . . . . .	61
3.3	Uses of equilibrium constants . . . . .	67
3.4	Effect of temperature on the equilibrium constant . . . . .	71
3.5	Applications of $K_{eq}$ for different types of chemical reactions . . . . .	72
▶	Chapter summary . . . . .	78
▶	Chapter review questions . . . . .	79

## Solution equilibria

81

4



4.1	Revision	82
4.2	Dissolution of ionic compounds	85
4.3	Measuring solubility	87
4.4	Australia's first peoples – removing toxicity from foods	91
4.5	Solubility rules	94
4.6	Solubility equilibrium	100
4.7	Relationship between the $K_{sp}$ and solubility	102
4.8	The common ion effect	107
▶	Chapter summary	113
▶	Chapter review questions	114

▶ End-of-module 5 review

115

## MODULE SIX » ACID/BASE REACTIONS

117

### Properties of acids and bases

118

5



5.1	Naming inorganic compounds	119
5.2	Properties of common inorganic acids and bases	122
5.3	Reactions of acids	125
5.4	Neutralisation reactions	128
5.5	Changes in understanding of acids and bases	135
▶	Chapter summary	140
▶	Chapter review questions	141

### Using Brønsted–Lowry theory

143

6



6.1	Brønsted–Lowry revisited	144
6.2	The pH scale	146
6.3	Concentration versus strength of acids and bases	152
6.4	Self-ionisation of water	158
6.5	Defining and calculating pOH	162
6.6	Applying dissociation constants for acids	165
6.7	Dissociation constants for bases	173
6.8	Revisiting neutralisation	178
▶	Chapter summary	186
▶	Chapter review questions	187





## 7

### Using quantitative analysis

189

7.1	Volumetric analysis – the basics	190
7.2	Primary standard solutions	195
7.3	Performing volumetric analysis	198
7.4	Other types of titrations	203
7.5	Keeping the balance	221
7.6	Applying analysis techniques	227
▶	Chapter summary	231
▶	Chapter review questions	232

▶ End-of-module 6 review

234

## MODULE SEVEN » ORGANIC CHEMISTRY

237

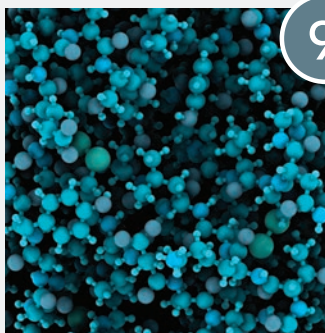


## 8

### Hydrocarbons

238

8.1	Bonding in carbon	239
8.2	Alkanes	242
8.3	Alkenes	246
8.4	Alkynes	249
8.5	Halogenated organic compounds	250
8.6	Isomers	253
8.7	Benzene	254
8.8	Properties of alkanes	256
▶	Chapter summary	259
▶	Chapter review questions	260



## 9

### Functional group compounds

262

9.1	Functional groups	263
9.2	Alcohols	264
9.3	Aldehydes and ketones	273
9.4	Carboxylic acids	276
9.5	Amines and amides	280
▶	Chapter summary	286
▶	Chapter review questions	287



## 10

### Hydrocarbon reactions

289

10.1	Using organic substances safely	290
10.2	Unsaturated hydrocarbon reactions	295
10.3	Saturated hydrocarbon reactions	299
10.4	Implications of obtaining and using hydrocarbons	303
▶	Chapter summary	312
▶	Chapter review questions	313

## Alcohols

315

11



11.1	Combustion of alcohols	316
11.2	Dehydration of alcohols	322
11.3	Substitution with hydrogen halides (HX)	322
11.4	Oxidation of alcohols	323
11.5	Production of alcohols	327
11.6	Fuels from different sources	333
▶	Chapter summary	338
▶	Chapter review questions	339

## Reactions of organic acids and bases

341

12



12.1	Esters	342
12.2	Preparing esters	344
12.3	Organic acids and bases	349
12.4	Soaps and detergents	352
12.5	Summarising organic compounds and reactions	360
12.6	Designing and constructing flow charts for chemical synthesis	362
▶	Chapter summary	365
▶	Chapter review questions	366

## Polymers

367

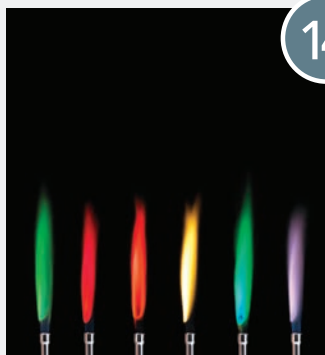
13



13.1	Synthetic polymers	369
13.2	Addition polymers	371
13.3	Relating properties, uses and structure	381
13.4	Condensation polymers	387
13.5	Natural polymers	393
▶	Chapter summary	398
▶	Chapter review questions	399

▶ End-of-module 7 review

401



<b>14</b>	<b>Analysis of inorganic substances</b>	<b>404</b>
14.1	Why monitor the environment?	405
14.2	Identifying ions in solution	407
14.3	Identifying of cations in solution	409
14.4	Identifying anions in solution	419
14.5	Quantitative analysis of ions	425
14.6	Instrumental quantitative techniques	434
	▶ Chapter summary	443
	▶ Chapter review questions	444



<b>15</b>	<b>Analysis of organic substances</b>	<b>447</b>
15.1	Chemical tests for functional groups	448
15.2	Analytical techniques: Faster and better	453
15.3	Mass spectroscopy	454
15.4	NMR spectroscopy	461
15.5	Infrared spectroscopy	469
15.6	Ultraviolet-visible spectrophotometry	475
15.7	Combining techniques	480
	▶ Chapter summary	482
	▶ Chapter review questions	483



<b>16</b>	<b>Chemical synthesis and design</b>	<b>487</b>
16.1	Synthesis reactions	488
16.2	Designing synthesis reactions	490
16.3	Yields of reactions	492
16.4	Issues associated with chemical synthesis	503
16.5	Green polymers – a case study in greening the plastics industry	506
	▶ Chapter summary	510
	▶ Chapter review questions	511

▶ **End-of-module 8 review** **512**

APPENDIX 1: PERIODIC TABLE	517
APPENDIX 2: RELATIVE ATOMIC MASSES (ATOMIC WEIGHTS) OF COMMON ELEMENTS	518
APPENDIX 3: GUIDELINES FOR USING SIGNIFICANT FIGURES	519
APPENDIX 4: COMMON IONS, ION COLOURS, FLAME COLOURS AND SOLUBILITIES	520
APPENDIX 5: COMMON UNITS OF MEASUREMENT	522
APPENDIX 6: ACID-BASE INDICATORS	523
APPENDIX 7: RELATIVE ACID STRENGTHS	524
APPENDIX 8: STANDARD ELECTRODE POTENTIALS AT 25°C	526
APPENDIX 9: DATA TABLES	527
STUDENT BOOK ANSWERS	530
GLOSSARY	540
INDEX	547

# INTRODUCTION

## About this book

*Chemistry in Focus Year 12* has been written to meet the requirements of the 2017 NESA Chemistry Stage 6 Syllabus.

## Approach to the syllabus

*Chemistry in Focus Year 12* presents a comprehensive coverage of the content of the syllabus, including many first-hand investigations written to reinforce the development of scientific investigation skills that this syllabus emphasises. The authors have presented a collection of investigations that will allow teachers to meet the 35-hour laboratory work component of the Year 12 syllabus. Chapter 1, 'Working scientifically and depth studies', is intended to help students develop skills in designing experiments and in planning and performing the depth study that is part of this syllabus.

## General structure

Chapters 2–16 are grouped into four modules as set out in the syllabus, with chapter titles related to the inquiry questions in the syllabus. Each module ends with an *End-of-module review* providing contextual questions and a list of *Suggestions for depth studies*. A glossary and numerical answers to questions are provided at the end of the book.

## Structure of chapters

Each chapter starts with an extract from the NESA syllabus that lists the Knowledge and Understanding core content points to be covered in that chapter. Headings and subheadings are used to divide the text into manageable portions. *Investigations* are incorporated into the chapter,

generally occurring quite early in the treatment of a topic to allow students to discover and explore key concepts before they are treated formally in the text. Strategically located through the chapter are sets of questions, called *Check your understanding*. These are a mixture of recall-type questions and simple applications of the preceding material designed to consolidate student learning.

Where appropriate, *Worked examples* are included. These are presented in a format that shows students how to go about solving the problem, with the logic provided for individual steps. Each worked example is followed by one or more *Try this yourself* questions, which provide students with the opportunity to solve new problems using the logic just presented.

Summaries of key concepts are located periodically throughout the chapter. These provide students an opportunity to consolidate their learning and they are a good starting point for students in preparing their own summaries, an important part of the learning process.

At the end of each chapter is a *Chapter summary*, which includes a list of *Important new terms* as an aid for student revision, a summary of the important concepts that students should understand and a list of key skills that students should have developed from studying the chapter. Then follows a set of *Chapter review questions*, which are a mixture of recall questions, simple one-step problems through to quite complex multi-step problems and scenario-type questions.

The later questions in these sets are intended to extend potential Band 6 students.

## To the student

The aim of *Chemistry in Focus* is to help you understand and use the basic concepts of chemistry. The emphasis is on 'elp'. You must make the effort and do the hard work to gain that understanding; no book or teacher can do it for you. But if you do make the effort, you will soon come to enjoy chemistry and the fascinating insights it provides into the world around us. The key to success is studying effectively.

## Effective study methods

For a good understanding of chemistry, you need to study regularly, methodically and without distractions, and you need to *apply* your knowledge to problem-solving and to test yourself frequently on what you have learnt. When you have a new piece of work to study, first skim through the chapter or portion of a chapter to get an idea of what it is about. Then read it carefully to understand what is being said, paying particular attention to the examples and illustrations, because they often get the message across better than descriptions. Write out and learn the important definitions and laws as they are introduced. Just as you cannot speak Italian or Indonesian until you know the vocabulary, so too you cannot speak chemistry unless you know the meaning of technical terms and the important laws.

When you think that you understand the material and know the necessary facts, try some of the questions in the *Check your understanding*. Try them when they occur in the text – they have been placed at strategic points where the authors think your understanding will be helped by working some examples. Generally in each set of questions the early ones are very simple, but gradually they get harder through the set. Answers are provided for all numerical exercises. Many of the exercises have several parts. There is no need to work through all parts on your first time through the book. Work through the first half or so, and keep the rest for revision. Do not despair if you find the exercises difficult at first. Go back over the text, particularly the worked examples; if you are still having difficulty, ask your teacher or a friend to help you with the first one or two, then try the rest on your own. Eventually you must be able to solve exercises on your own, so do not rely on helpers for too long!

## Key aspects

Three of the key aspects of succeeding at chemistry are being able to:

- write formulae for compounds without having to memorise them

- write chemical equations for common types of reactions, regardless of which particular compounds are involved
- do simple quantity calculations based on chemical formulae and equations.

Hence, this book places great emphasis on developing these skills – they take time, patience and perseverance for mastery, but the rewards are worth it.

In chemistry, as in mathematics and physics, the emphasis is on using the information acquired – working questions and solving problems. Assimilation of facts is necessary but it is not sufficient. So develop the habit of working through questions – and persevering with them until you get them correct – right from the beginning of your course.

## Other useful study hints

- *Use the glossary and the index.* If, in studying a particular chapter, you cannot remember the meaning of a particular term, look it up so you can better understand the argument at hand.
- *Look up cross-references.* If the topic you are currently reading refers to a previous section, look it up to make sure you know what it is all about. Interconnecting today's study with last week's or last month's work is an important part of learning.
- *Set out your exercises systematically and neatly.* This will help you develop logical arguments and make it easy for you to check for errors in your work or for your teacher to diagnose where you are having problems. The worked examples in this text should serve as good models for your own work.
- *Take time to understand the concepts.* If you are having difficulty with questions based on a particular topic, take the time to read the relevant part of the text carefully and study it thoroughly. Do not just grab a formula or copy a worked example. Time spent getting to understand the basic idea is definitely not time wasted, even when the object is to get some homework exercises done!

You will enjoy chemistry when you can succeed at it (just as you enjoy tennis, dancing or playing an instrument when you can do it properly). Success in chemistry requires perseverance and practice.



# AUTHOR TEAM

## Anna Davis

Anna Davis is the Leader of Learning: Science at Casimir Catholic College in Sydney. She has extensive experience as a marker and senior marker for the HSC Chemistry examination. Anna has been a contributing writer for several of the National Science Week Resource books developed by the Australian Science Teachers' Association (ASTA) and was the convenor of CONASTA 61, the conference of ASTA. She was involved with the development of the Australian Curriculum – Science. Anna has contributed to other Cengage Nelson publications, including *iScience* for NSW and *Chemistry for the Australian Curriculum*. Anna is also a Past President of ASTA and is both a Life Member and Past President of the Science Teachers' Association of New South Wales. She has extensive experience presenting professional learning events for science teachers throughout NSW in programming and assessment. In 2006, Anna was awarded the Prime Minister's Prize for Excellence in Science Teaching in Secondary Schools.

## Anne Disney

Anne Disney is an experienced Chemistry and Physics teacher and is currently in charge of Stage 6 Science at Knox Grammar School as Assistant Head of Department. She has worked in the Northern Territory/South Australian and NSW systems, and was an exam marker and moderator in the South Australian system for both Chemistry and Physics for a number of years. Anne has extensive experience in programming, and was a member of the Australian Curriculum Advisory Committee during the development of the national Physics curriculum.

## Debra Smith

Debra Smith is an experienced Chemistry teacher and author. Debra has been Head of Science at a number of high schools and been involved in writing science curriculum at the local, state and national levels. She has been President and Treasurer of the Australian Science Teachers' Association. For her contribution to science education, Debra was awarded the 2010 Prime Minister's Prize for Excellence in Science Teaching in Secondary Schools.

# AUTHOR ACKNOWLEDGEMENTS

Anne Disney would like to thank Andrew Weeding for enduring constant questions and offering advice and suggestions. Thanks also to Kylie Horton for putting up with my hours at the computer and the constant supply of great food and much needed coffee.

Debra Smith would like to thank Joe Sambono for his valuable knowledge and review of the Aboriginal and Torres Strait Islander material.

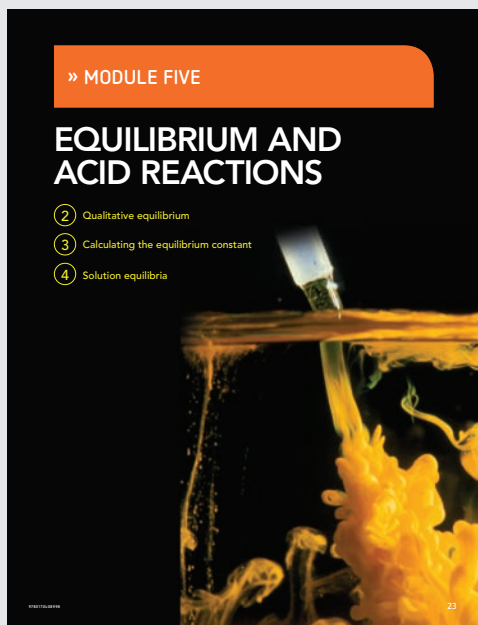
# PUBLISHER ACKNOWLEDGEMENTS

Eleanor Gregory sincerely thanks Anna, Debra and Anne for their perseverance and dedication in writing this manuscript. She also thanks Deborah de Ridder, Jason Smith and Rachel Whan for reviewing the manuscript to ensure that it was of

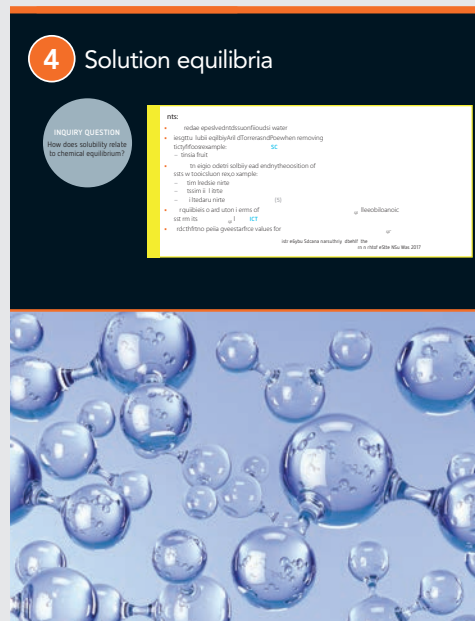
the best quality. Further thanks to Anna Davis, Anne Disney, Gillian Dewar, Debra Smith and Rachel Whan for writing the online NelsonNet student and teacher material.

# USING CHEMISTRY IN FOCUS

*Chemistry in Focus Year 12* has been purposely crafted to enable you, the student, to achieve maximum understanding and success in this subject. The text has been authored and reviewed by experienced chemistry educators, academics and researchers to ensure up-to-date scientific accuracy for users. Each page has been carefully considered to provide you with all the information you need without appearing cluttered or overwhelming. You will find it easy to navigate through each chapter and see connections between chapters through the use of margin notes. Practical investigations have been integrated within the text so you can see the importance of the interconnectedness between the conceptual and practical aspects of chemistry.



The content is organised under four modules as set out in the NESA Stage 6 Chemistry syllabus. Each module begins with a module opening page.



Each chapter begins with a **chapter opening** page. This presents the learning outcomes from the NESA Stage 6 Chemistry syllabus that will be covered in the chapter and also gives you the opportunity to monitor your own progress and learning.

To improve comprehension, a number of strategies have been applied to the preparation of our text to improve literacy and understanding. One of these is the use of shorter sentences and paragraphs. This is coupled with clear and concise explanations and real-world examples. New terms are bolded as they are introduced and are consolidated in an end-of-book glossary.

Throughout the text, important ideas, concepts and theories are summarised in **key concept** boxes. This provides repetition and summary for improved assimilation of new ideas.

tetnotants and  
hooum.  
e ,emsoet.  
e ,emsoet.

**Learning across the curriculum content** has been identified by NESA as important learning for all students. This content provides you with the opportunity to develop general capabilities beyond the Chemistry course, as well as links into areas that are important to Australia and beyond. This content has been identified by a margin icon.



Mathematical relationships are presented in context. Step-by-step instructions on how to perform mathematical calculations are shown in the **worked examples**. The logic behind each step is explained and you can practise these steps by attempting the related problems presented at the end of the worked example.

**EXAMPLE 3**

Write the following insoluble compounds as oxides and phosphates.

Chemical Formula	IC
$\text{Ca(OH)}_2$	Calcium hydroxide
$\text{H}_2\text{SO}_4$	Sulfuric acid
$\text{Fe}_2\text{O}_3$	Iron(III) oxide
$\text{Na}_2\text{CO}_3$	Sodium carbonate
$\text{Al}_2\text{O}_3$	Aluminium oxide
$\text{H}_2\text{O}$	Water
$\text{H}_2\text{S}$	Sulfuric acid
$\text{H}_2\text{SO}_3$	Sulfurous acid
$\text{H}_2\text{S}_2\text{O}_7$	Pyrosulfuric acid
$\text{H}_2\text{S}_2\text{O}_8$	Persulfuric acid
$\text{H}_2\text{S}_2\text{O}_5$	Pyrosulfuric acid
$\text{H}_2\text{S}_2\text{O}_4$	Pyrosulfuric acid
$\text{H}_2\text{S}_2\text{O}_3$	Pyrosulfuric acid
$\text{H}_2\text{S}_2\text{O}_2$	Pyrosulfuric acid
$\text{H}_2\text{S}_2\text{O}$	Pyrosulfuric acid

Chemistry is a science and you need to be given the opportunity to explore and discover the chemical world through practical investigations. Investigations introduce and reinforce theoretical concepts listed in the NESA Stage 6 Chemistry syllabus. In some cases, the investigations are open-ended. These provide you the opportunity to design and carry out your own scientific investigation, either individually or in a group. At times you are prompted to consider ideas for improvement or further investigation to illustrate that science is an ongoing and dynamic process. At other times investigations are secondary-sourced, meaning that you need to research the subject using data and information gained by other people. Further information on how to conduct scientific investigation can be found in the scientific investigations and depth studies chapter on page 387.

**INVESTIGATION**

**rural indicators**

**OBJECTIVE**

Use natural indicators to determine the pH of various substances.

**METHOD**

Use natural indicators to determine the pH of various substances.

The **risk assessment** table occurs within the investigations. The table highlights the risks of the investigation and provides suggestions on how to minimise these risks – they are not to be considered comprehensive. Teachers are expected to amend this table in the case of substitutions or in the case of any additional risks. This may mean obtaining and following Safety Data Sheets (SDS) for certain chemicals. All teachers are required to follow the safety guidelines of their specific school and associated government legislation when students are in their care.

Full understanding of a concept is often constructed from many pieces of information. Due to the sequential nature of a book, this information cannot always be presented together as

Amphoteric substances were discussed in section 52 page 124

its best placed in other chapters. Links between concepts that occur on other pages and chapters are indicated using the **main notes**.



Regular opportunities to recall new terms and review recent concepts are provided as short **check your understanding** question sets throughout each chapter.

- CHECK YOUR UNDERSTANDING 6.4**
- Write the equation to show the self-ionisation of water.
  - Write the  $K_w$  expression for water. Include the numerical value of  $K_w$  at 25°C.
    - Explain why  $[\text{H}_2\text{O}]$  is not included in the  $K_w$  expression.
  - Determine the concentrations of  $\text{H}_3\text{O}^+$  and  $\text{OH}^-$  in aqueous solutions of:
    - black coffee (pH = 5.0)
    - dishwasher liquid (pH = 13.0)
    - cola drink (pH = 3.0).
  - Determine the pH of each of the following substances that ionise or dissociate completely into ions in aqueous solution.

The **chapter review** section, which appears at the end of each chapter, provides the following:

- a list of **important new terms**
- a **chapter summary** that lists the important concepts and skills. This will be a valuable tool when you are revising for tests and exams

**7 CHAPTER SUMMARY**

**IMPORTANT NEW TERMS**

A study of the chapter should now have the meaning of the following terms:

acid (p. 1)	equivalence point (p. 19)
alkali (p. 1)	indicator (p. 1)
alkaloid (p. 30)	ion (p. 19)
alkene (p. 229)	ionisation (p. 19)
alloy (p. 19)	isomer (p. 19)
alkyne (p. 208)	it (p. 19)

- end-of-chapter review questions** that review understanding and provide opportunities for application and analysis of concepts and how they interrelate.

**RRW QUESTIONS**

Write the following chemical equations:

- $\text{Ca} + \text{H}_2\text{O}$
- $\text{Fe} + \text{H}_2\text{SO}_4$
- $\text{Al} + \text{H}_2\text{SO}_4$

Each module concludes with a **module review**. This contains short-answer questions that provide you with the opportunity to assimilate content that may occur across the chapters that fall within that module.

**» END-OF-MODULE REVIEW** **MODULE 5: EQUILIBRIUM AND ACID REACTIONS**

Answer the following questions.

- Nitric oxide reacts with oxygen to form nitrogen dioxide:
 
$$2\text{NO}(\text{g}) + \text{O}_2(\text{g}) \rightleftharpoons 2\text{NO}_2(\text{g})$$
 The following table gives the equilibrium constant for this reaction at different temperatures.
 

TEMPERATURE (°C)	EQUILIBRIUM CONSTANT
477	1.12
727	1.60
1227	$2.4 \times 10^{-2}$
- The production of sulfuric acid involves a number of steps, one of which is the gaseous equilibrium reaction between sulfur dioxide and oxygen to form sulfur trioxide. A scaled-down version of the reaction was performed in a 3L container. Initially, 0.18 mol of sulfur dioxide was added to 0.15 mol of oxygen. After equilibrium was reached, the concentration of sulfur trioxide was 0.12 mol/L. Calculate the equilibrium constant for the reaction.
- Ammonia is produced from nitrogen and hydrogen in the Haber process:
 
$$\text{N}_2(\text{g}) + 3\text{H}_2(\text{g}) \rightleftharpoons 2\text{NH}_3(\text{g})$$
 The graph below shows the variations in the

The **depth study** provides you with the opportunity to pursue a topic of interest from within the course. It enables you to study a topic in more depth and present your findings in a format of your choice. Advice and support to assist you in undertaking your depth study can be found in chapter 17, as well as suggestions for topics provided at the end of each module review. Refer to the NESAs Stage 6 Chemistry syllabus for the full details on scoping and completion of your depth study.

#### DEPTH STUDY SUGGESTIONS

- Conduct an investigation using colourimetry to determine the  $\lambda_{max}$  of an indicator.
- Research the use of different analysis techniques in the wine industry.
- Conduct an investigation to identify the presence of cations and/or anions in a sample of contaminated water.
- Conduct gravimetric analysis to compare the sulfate content of different brands of fertiliser.

## NelsonNet

NelsonNet is your protected portal to the premium digital resources for Nelson textbooks, located at [www.nelsonnet.cm.au](http://www.nelsonnet.cm.au). Once your registration is complete you will have access to a helpful suite of digital resources for each chapter to further enhance and reinforce learning.

Each chapter will be supplemented with the following digital resources.

- Worksheets to review concepts and to practise applying understanding to new examples
- A review quiz containing 20 auto-correcting multiple-choice questions to review understanding
- Links to websites that contain extra information. These are hotspotted within the NelsonNetBook and they can also be accessed at <http://chemistryinfocus12.nelsonnet.com.au>

## Disclaimer

Please note that complimentary access to NelsonNet and the NelsonNetBook is only available to teachers who use the accompanying student textbook as a core educational resource in their classroom. Contact your sales representative for information about access codes and conditions.

# OUTCOME GRID

## Working Scientifically mapping

Content statements from the NESAs Stage 6 hemistry syllabus are hown in full on the chapter opening pages of the chapters where they are dealt with. A full mapping of chapters and content statements can be found on the NelsonNet Teacher website. Below is a mapping of the outcome statements for Working scientifically across all the chapters of *Chemistry in Focus Year 12*.

OUTCOME STATEMENTS STUDENTS:																	
		1	2	3	4	5	6	7	8	9	10	11	12	13	14	15	16
1	CH11/12-1 develops and evaluates questions and hypotheses for scientific investigation	✓	✓		✓	✓	✓	✓		✓	✓	✓		✓	✓	✓	✓
2	CH11/12-2 designs and evaluates investigations in order to obtain primary and secondary data and information	✓	✓	✓	✓		✓	✓		✓		✓		✓	✓	✓	✓
3	CH11/12-3 conducts investigations to collect valid and reliable primary and secondary data and information	✓	✓	✓	✓	✓	✓	✓	✓	✓	✓	✓	✓	✓	✓	✓	✓
4	CH11/12-4 selects and processes appropriate qualitative and quantitative data and information using a range of appropriate media	✓	✓	✓	✓	✓	✓	✓	✓	✓	✓	✓	✓	✓	✓	✓	✓
5	CH11/12-5 analyses and evaluates primary and secondary data and information	✓	✓	✓	✓	✓		✓	✓	✓	✓	✓	✓	✓	✓	✓	✓
6	CH11/12-6 solves scientific problems using primary and secondary data, critical thinking skills and scientific processes	✓	✓	✓	✓	✓	✓	✓	✓	✓	✓	✓	✓	✓	✓	✓	✓
7	CH11/12-7 communicates scientific understanding using suitable language and terminology for a specific audience or purpose	✓	✓	✓	✓	✓	✓	✓	✓	✓	✓	✓	✓	✓	✓	✓	✓





# 1

## Working scientifically and depth studies

### Students:

CH12-1 develops and evaluates questions and hypotheses for scientific investigation

CH12-2 designs and evaluates investigations in order to obtain primary and secondary data and information

CH12-3 conducts investigations to collect valid and reliable primary and secondary data and information

CH12-4 selects and processes appropriate qualitative and quantitative data and information using a range of appropriate media

CH12-5 analyses and evaluates primary and secondary data and information

CH12-6 solves scientific problems using primary and secondary data, critical thinking skills and scientific processes

CH12-7 communicates scientific understanding using suitable language and terminology for a specific audience or purpose.

Chemistry Stage 6 Syllabus © NSW Educational Standard Authority for and on behalf of the Government of New South Wales, 2017





**FIGURE 1.1** Science is characterised by a way of thinking, working and questioning.

This chapter is primarily designed to assist students with the **depth study** section of the syllabus. The syllabus indicates that all depth studies must address the following outcomes:

- ▶ CH12-1 – questioning and predicting
- ▶ CH12-7 – communicating.

Therefore, significant parts of this chapter have focused on addressing these outcomes. The information in this chapter may also assist with performing other investigations throughout the course.

Science is the systematic study of the natural and physical world. This study involves both observing the natural and physical world and conducting investigations on it. Science is **empirical**, which means that scientists answer questions by using evidence – in particular, observational and experimental evidence.

## 1.1 The nature of chemistry

Scientific knowledge and theories are able to be tested. Importantly, they are open to being disproved, that is, they are **falsifiable**. Scientists are never able to state that a theory has been proven, they are only able to state that there is a considerable body of evidence available that supports the theory. However, if evidence is available that does not support the theory, then the theory is disproved. Hence, a theory can be disproved but can never be proved. Einstein stated this eloquently, when he said, ‘No amount of experimentation can ever prove me right; a single experiment can prove me wrong.’

If there is a large body of evidence available to support a theory, then it is widely accepted by the scientific community. An example of this is atomic theory. At present, there is a very large body of evidence that supports this theory. It has been used to make predictions about atoms and evidence has been collected that supports these predictions. Hence, it is widely accepted by the scientific community that all matter is made of atoms.

Not all scientific theories that have been proposed over time are still accepted. An example is the phlogiston theory. Phlogiston was first mentioned by Johann Becker in the mid-late 1600s. The phlogiston theory was used to explain combustion. It indicated that when a substance was combusted, it released another substance called phlogiston. This suggested that the product of the combustion reaction had less mass than the reactant in the reaction. However, over time, as further experimentation occurred, it was found that some substances increased in mass when they were combusted (for example, burning magnesium). The phlogiston theory was widely accepted until the late 1700s when Antoine Lavoisier published his work that involved measurements of closed reaction vessels. He found that a gas, now known to be oxygen, was needed for combustion to occur.

This theory of phlogiston is an example of how the theory fitted the body of evidence available in the late 1600s. However, more evidence was gathered throughout the 1700s that was found not to support the phlogiston theory. The theory was disproved and so the theory was no longer widely accepted by the scientific community.

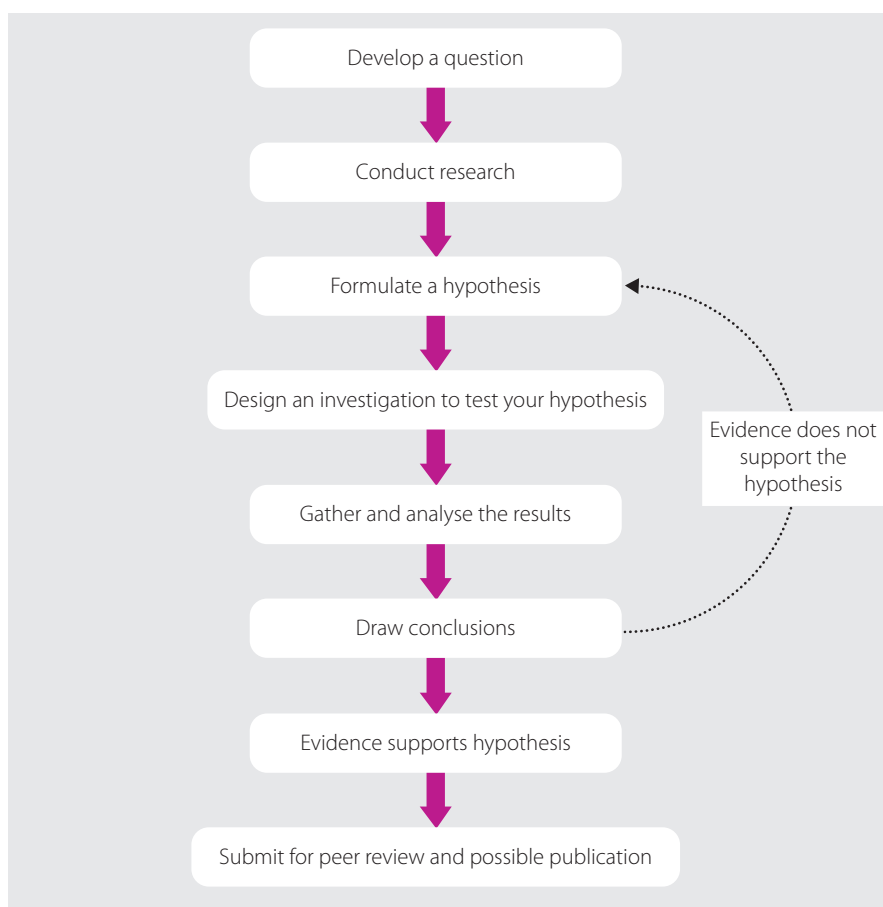
## The scientific method



The **scientific method** (Figure 1.2) involves systematically gathering data to investigate phenomena. The gathering of data involves both observations and measurements. This data is used to formulate, test and/or modify hypotheses. A **hypothesis** is the tentative answer to a question, which can then be tested. A hypothesis is not a wild guess; it is based on simple observations or a search of the literature. For example, it might be hypothesised that temperature affects the rate of a chemical reaction. This could be tested by measuring the time for a particular reaction to occur at different temperatures.

Once the hypothesis has been formulated, an investigation is designed and performed to test the hypothesis. Results are collected and analysed. If the results support the hypothesis, then this increases the body of evidence for the idea or model or theory. If the results do not support the hypothesis, then the scientists need to modify their hypothesis and then test this modified hypothesis.

Scientists submit their work to journals for peer review. This is where other scientists, who are experts in the particular field of research, evaluate the scientists' methodology, results, analysis of results and conclusions. If they decide that it is contributing to the scientific body of knowledge and the investigation and its conclusions are **valid**, then the work is published.



**FIGURE 1.2** Diagrammatic representation of the scientific method



### Science and pseudoscience

Read this article about the scientific method and come up with your own explanation of the difference between science and pseudoscience.

## Chemistry – the central science

Chemistry is considered the ‘central science’ since an understanding of chemistry is necessary to understand many other branches of science. To understand metabolism in the human body, an understanding of chemical reactions and catalysis is required. To understand how metals are extracted from their ores, an understanding of properties of substances, methods of separation and chemical reactions is required.

Chemistry can be viewed both macroscopically and microscopically. The macroscopic level involves what can be seen, such as colour changes, bubbling and explosions. The microscopic level involves what happens at the atomic, molecular and ionic level.

Chemistry involves questions about the structures of substances. Understanding structures leads to an understanding of the properties of the substance and this in turn leads to the possibility of particular uses or potential uses of the substance. Chemistry also involves questions about how substances interact with other substances. These interactions may be either chemical or physical. By understanding chemical reactions, chemists are able to manipulate a reaction to increase yield or change its rate or even change the products formed.

Energy is an important consideration in chemistry. Energy is a driver of chemical reactions; it determines whether the reaction occurs or not. If the reaction occurs, energy determines in which direction it occurs.

**Models** are integral to the study of chemistry. Since atoms cannot be seen, chemists use models to help visualise what is happening at the atomic, molecular and ionic level. They use results from investigations to develop models, then use the models to predict a particular structure or property or chemical change of a substance. Further investigations are performed to evaluate these models. Hence, the cycle continues.

## 1.2

## Solving scientific problems – depth studies

Depth studies are your opportunity to work scientifically and solve scientific problems. They enable you to pursue a particular area of interest that is related to one or more concepts found within the course. When performing a depth study, you will pose questions, develop hypotheses to answer your questions and then seek evidence to support or disprove your hypotheses. The evidence may come from your own experiments or from the existing scientific literature. You will need to analyse data to determine whether or not your hypotheses are supported. Analysing data usually requires you to represent it in some way, often mathematically or graphically. Finally, you will need to communicate your finding to others, just as scientists do. There are many ways that you can do this, and you need to choose the method most appropriate to the audience to whom you wish to communicate your findings.

Sometimes scientists work individually, though more often they work collaboratively with others. Different members of the research team may have different roles and responsibilities. This can also occur when completing your depth study since it can be done either individually or collaboratively.

Completing a depth study allows you, either individually or collaboratively to:

- put into practice the skills of working scientifically
- deepen your understanding of a specific course concept
- compare claims in the media with information found in the scientific literature
- develop and perform investigations to test claims about products or claims made in the media related to a specific course concept

- ▶ search the literature to produce a coherent response on the development of our understanding about a chemical concept over time
- ▶ analyse data to draw out important trends or key information.

## Types of depth study

There are two main types of depth study.

- ▶ During **primary source investigations** you physically perform the investigation and collect your own data. This data may be from fieldwork or investigations conducted in the laboratory or at home. Working models are also considered to be first-hand investigations since you are constructing the model.
- ▶ In **secondary source investigations** you use data or information collected by someone else. It usually includes a search of the literature. Analysing the historical development of a chemistry concept is an example of a secondary source investigation.

Depth studies may be presented in a variety of ways, some of which include:

- ▶ scientific reports
- ▶ media articles
- ▶ video or animation
- ▶ poster presentation.

Depth studies always involve the analysis of data. It is important that this is presented in a way that makes it easy to understand (for example, tables, graphs, flow charts and diagrams such as graphic organisers).

## Stages in a depth study

The summary below outlines four main stages of conducting a depth study, as well as the Working scientifically skills that you will need to develop and apply at each stage.

- 1 Initiating and planning involves:
  - ▶ Questioning and predicting (CH12-1): formulating questions or hypotheses
  - ▶ Planning investigations (CH12-2): researching background information; assessing risks and ethical issues; planning valid experiments
- 2 Implementation and recording
  - ▶ Conducting investigations (CH12-3): safely carrying out valid investigations using appropriate technology and measuring instruments
  - ▶ Processing data and information (CH12-4): collecting, organising, recording and processing data/information
- 3 Analysing and interpreting
  - ▶ Analysing data and information (CH12-5): looking for trends or patterns, finding mathematical relationships and evaluating data
  - ▶ Problem solving (CH12-6): drawing and justifying conclusions, testing hypotheses and answering questions
- 4 Communicating (CH12-7)
  - ▶ Using appropriate language, visualisations and technologies to communicate scientific ideas, procedures and results



## Record keeping – your logbook

You will need to keep a record of what you do during your investigation. You do this in a **logbook**. Scientists keep a logbook for each project that they work on. A logbook is a legal document for a working scientist. If the work is called into question, then the logbook acts as important evidence. Every entry in a scientist's logbook is dated, records are kept in indelible form (pen – not pencil), and entries may even be signed. Scientists' logbooks include:

- details of experiments, such as methods and results
- comments and ideas
- thoughts about experiments and analysis
- printouts of data
- photocopies of relevant information
- photos and other items.

The logbook is the primary source of information when scientists write up their work for publication. Logbooks are sometimes provided as evidence in court cases; for example, in patent disputes or when a researcher is accused of falsifying data or stealing someone else's results.

Your logbook may be a hard copy or an electronic record. Either way, your logbook is a detailed record of *what you did* and *what you found out* during your investigation. Make an entry in the logbook *every* time you work on your depth study. At the start of each session, you should record the date and the names of all the people with whom you are working at the time. A logbook is an important part of any investigation, regardless of whether it is a primary source investigation or a secondary source investigation.



**FIGURE 1.3** Make sure you keep an accurate record of what you do as you do it.

Always write down what you do as you do it (Figure 1.2). It is easy to forget what you did if you do not write it down immediately. Annotated diagrams are often a concise way of presenting ideas and information.

Record the results of all measurements immediately and directly into your logbook, and in pen if using a hard copy. *Never* record data onto bits of scrap paper instead of your logbook! Results must be recorded in indelible form. Never write your results in pencil or use white-out. If you want to cross something out, just put a line through it and make a note explaining why it was crossed out. If you are using an electronic logbook, then do not delete data or working or calculations; instead, use tracked changes or the strikethrough feature and add a comment explaining why it was crossed out. Your teacher will advise whether an electronic logbook is acceptable.

- A good logbook contains:
  - notes taken during the planning of your investigation
  - a record of when, where and how you carried out each experiment
  - diagrams showing the experimental set-ups, circuit diagrams, etc.
  - all your raw results
  - all your derived results, analysis and graphs
  - all the ideas you had while planning, carrying out experiments and analysing data
  - printouts, file names and locations of any data not recorded directly in the logbook.
- A logbook is not a neat record, but it is a complete record.

## 1.3 Designing your investigation

There are many things to consider when designing an investigation. You need to consider the time available and the resources that might be required. However, a starting point is to come up with a **research question** or hypothesis.



### Posing questions and formulating hypotheses

It is a good idea to investigate something that you find interesting. A good way to start is by 'brainstorming' for ideas. This is useful whether you are working on your own or in a group. Write down as many ideas as you can think of. Do not be critical at this stage. Get everyone in the group to contribute and accept all contributions uncritically (Figure 1.4). Write down all ideas.

After you have run out of ideas, it is time to start being critical. Decide which questions or ideas are the most interesting. Think about which of these it is possible to investigate scientifically given the time and resources available. Do not forget that the most important resources you have are the skills of the people in the group. Make a shortlist of questions, but keep the long list too for the moment. Once you have your shortlist, it is time to start refining your ideas.



FIGURE 1.4 Brainstorm as many ideas as you can in your group.

### Refining your question – literature review

Your depth study will be based on one of the chemical concepts that you have encountered during this course. However, the purpose of a depth study is to *extend* your knowledge, while at the same time building your skills at working scientifically. So you will need to go beyond the basic syllabus content.

The next step is to find out what is already known about the ideas on your list. You need to do a literature review. A **literature review** is more than just summarising information found in the literature. It involves coherently presenting the research available on the topic and critically analysing the research in terms of methodology and data analysis and identifying areas where further research could be conducted.

All investigations involve a search of the literature to help deepen your understanding and to help explain the chemistry related to your area of study. However, some secondary source investigations are completely based on performing a formal literature review.

Many universities have guidelines for conducting a literature review, two of which are included in the weblinks here.

Use the Internet, your textbooks and the library, but be critical of what you read. Be wary of pseudoscience, and any material that has not been peer reviewed. Apply the CRAAP test to websites that you find. The most valid sites are from educational institutions, particularly universities, government and scientific organisations such as the CSIRO and ANSTO, and professional organisations such as the Royal Australian Chemical Institute and international equivalents. You can narrow your search to particular types of sites by including in your search terms 'site:edu' or 'site:gov' so that you only find sites from educational or government sources.



Conducting a literature review



The CRAAP test  
Apply the CRAAP test to any websites that you find.



**FIGURE 1.5** Start researching your topic and make sure you keep a record of all of your references. Good record keeping is important in scientific research, and it begins at this stage of the investigation.



**FIGURE 1.6** Your research question will guide the investigation. These students are finding out how temperature affects the rate of a reaction.

Scientists use a logbook to record all of the work that they do, including recording information that they've found, any relevant references and by attaching printouts (Figure 1.5). You should also use a logbook to record this information. It can save you a lot of time later on!

Finally, talk to your teacher about your ideas. They will be able to tell you whether your ideas are likely to be possible given the equipment available. They may have had students with similar ideas in the past and can make suggestions.

After you have researched your questions and ideas, you will hopefully be able to narrow down the shortlist to the one question that you want to tackle. If none of the questions or ideas look possible (or interesting), then you need to go back to the long list.

## Proposing a research question or hypothesis

If you are doing an investigation, then you need to define a research question or a hypothesis.

You need to frame the question carefully. It needs to be specific enough that it guides the design of the investigation (Figure 1.6). A specific question rather than a vague one will make the design of your investigation much easier. Asking 'Will a reaction occur more quickly if the temperature is higher?' tells you what you will be varying and what you will be measuring. It also gives a criterion for judging whether you have answered the question.

Asking 'What will make a reaction occur the best?' is not a good question. This question does not say what will be varied, nor does it tell you when you have answered the question. 'Best' is a vague term. What you mean by 'best' may not be what someone else means by 'best'.

A good research question identifies the variables that will be investigated. All other variables should be **controlled variables**. Usually, there will be one **independent variable** and one **dependent variable**. When

performing an extended investigation such as a depth study, you may test two or more independent variables. However, you only test one variable in any particular experiment. Finally, a good research question should be answerable with the time and equipment available.

A hypothesis is a tentative explanation or prediction, not yet confirmed by experiment, as in 'As the temperature of the sodium thiosulfate solution increases, the rate of reaction with the hydrochloric acid will increase'. Your hypothesis should give a prediction that you can test, ideally quantitatively.

A hypothesis is usually based on an existing model or theory. It is a prediction of what will happen in a specific situation based on that model. For example, collision theory is used to describe what happens during a chemical reaction. This can be used to develop a hypothesis regarding factors that affect the rate of a reaction, including temperature.

- A good research question is specific and can be answered by performing experiments and making measurements. A good hypothesis is a statement that predicts the results of an experiment and can be tested using measurements.

If your experimental results disagree with your hypothesis, then you may have disproved it. This is *not* a bad thing! Often the most interesting discoveries in science start when a hypothesis based on an existing model is disproved, because this raises more questions such as 'Is there a better model that can be developed to fit the growing body of evidence?'

Even if your question or hypothesis meets these criteria, do not be surprised if you change or modify it during the course of your investigation or depth study. In scientific research, the question you set out to answer is often only a starting point for more questions.

- If your experiments agree with predictions based on your hypothesis, then you can claim that they support your hypothesis. This *increases your confidence* in your model, but it *does not prove that it is true*. Hence, an aim for an experiment should *never* start 'To prove ...', since it is not possible to actually prove a hypothesis, only to disprove it.

## Designing and planning your scientific investigation

There are many things to consider when planning an investigation. You need to think about what is the most appropriate equipment to use to collect the data that is required for the investigation. For example, measuring cylinders are familiar pieces of equipment for measuring volumes; however, it may be more appropriate to use a more precise measuring instrument such as a volumetric flask or a burette or a pipette.

You also need to think through the order in which tasks should be performed so that the investigation is completed in a time-efficient manner. There may be other students/groups who require the same specialist equipment that you intend to use. In this case, you will need to liaise with the other students/groups regarding the use of the equipment so that both investigations can continue in a timely manner. If you are conducting the depth study in a group, you need to think about who is best suited to particular roles within the group and ensure that the work is shared equally.

It is important that you keep focused on the purpose of your investigation. At the end of the process, you need good data that answers your question or tests your hypothesis. Having a plan helps you to ensure that you collect the data, whether primary or secondary, that you need to test your hypothesis. The longer the investigation, the more important it is that you have a clear plan. Table 1.1 presents questions that need to be considered whether you are performing a primary source investigation or a secondary source investigation.



**TABLE 1.1** Comparison of considerations for both primary source investigations and secondary source investigations

PRIMARY SOURCE INVESTIGATION	SECONDARY SOURCE INVESTIGATION
What data will you need to collect?	What information will you need to gather?
What materials and equipment will you need?	What sources will you use?
When and where will you collect the data?	When and where will you gather the information?
If you are working in a group, what tasks are assigned to which people?	If you are working in a group, what tasks are assigned to which people?
Who will collect the data?	Who will collect what information?
Who will be responsible for record keeping?	How will record keeping be done to avoid plagiarism?
How will the data be analysed?	How will the information be analysed?
How will sources be referenced?	How will sources be referenced?



You also need to ensure that your investigation is valid and reliable and that any numerical data is precise. The questions in Table 1.2 may help with this.

**TABLE 1.2 Assessing validity, reliability and precision in investigations**

	PRIMARY INFORMATION AND DATA	SECONDARY INFORMATION AND DATA
Validity	Does the investigation test the hypothesis? Have all variables been controlled (controlled variables), except the one being investigated?	Does the information relate to the investigation's hypothesis? Is the author qualified for doing research in this area of chemistry? When was the research published? (i.e. Is there more recent research that is more relevant to the investigation?)
Reliability	Has the method been repeated an appropriate number of times? Are the results consistent?	Is the information found in several authoritative sources consistent?
Precision and accuracy	Have I used the best measuring equipment available, and used it correctly? Have I designed my experiments to minimise uncertainties?	Does the data have uncertainties and are these uncertainties small compared to the measured values?

In your planning, ensure that you only change one variable – the independent variable. All other variables need to be kept constant. You need to show how this will be achieved. For example, clearly indicate the volume and concentration of solutions that you will use, the order chemicals will be added and how a stopwatch might be used.

Whenever possible, repeat measurements. This allows you to check that your measurements are **reliable**. Your results are reliable if repeat measurements give the same results within experimental **uncertainty**. If a result is not **reproducible**, it is not a reliable result. If a result is not reproducible, then a variable other than the one you are controlling is affecting its value. If this is the case, you need to determine what this other variable is, and control it if possible.

When working with numerical data, you also need to consider how many data points to collect. In general, it is better to have more data than less. However, you will have limited time to collect your data, and you need to allow time for analysis and communication of your results. A minimum of 6 to 10 data points is usually required to establish a relationship between variables, if the relationship is linear. A linear relationship is one where if you plot one variable against the other you get a straight line. If you think the relationship might not be linear then take more data points, and think carefully about how they will be spaced. You should try to collect more data in the range where you expect the dependent variable to be changing more quickly (for example, when you are measuring temperatures to identify the boiling point of a substance).

The most common problem that students have is time management. It is important to plan to have enough time to perform the experiments, including repeat measurements, *and* to analyse them, *and* to report on them. You also need to allow time to learn how to use particular equipment if you haven't used it before.

Keep a record of your planning in your logbook. Record what you plan to do, and why and this will help you stay focused during the investigation. This is particularly important for a depth study. If you are working in a group, then keep a record of what each person agrees to do. Table 1.3 gives an idea of the types of things you should think about.



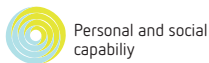
**TABLE 1.3** Depth study plan

INTRODUCTION TO DEPTH STUDY PLAN		
<b>Title</b> What?	Choose a title for your depth study.	
<b>Rationale</b> Why?	Explain why you have chosen this area of research. Describe what you are hoping to achieve through this investigation. Include any ways you think your investigation may benefit yourself, your class and possibly your family/friends/the school/wider community (if applicable).	
<b>Type of depth study and research model (where applicable)</b> Which?	State the type of depth study you intend conducting (e.g. literature review/practical investigation, etc.). Where applicable, describe any theoretical models that you will use for your depth study. Include references to your reading and explain why you chose this model.	
TIMELINE		
<b>ACTION AND TIME FRAME</b> When?	<b>WORKING SCIENTIFICALLY SKILLS</b> How?	
<b>1 Initiating and planning</b> When? (e.g. week 1–2)	<i>Questioning and predicting:</i> formulate questions and/or a hypothesis; make predictions about ideas, issues or problems. <i>Planning:</i> wide reading – research background information; assess risks and ethical issues; plan valid, reliable and <b>accurate</b> methods; select appropriate materials and technologies; identify variables; plan experimental controls and how to measure them.	
<b>2 Implementation and recording</b> When? (e.g. week 2–4)	<i>Conducting investigations:</i> safely carry out valid investigations; make observations and/or accurate measurements; use appropriate technology and measuring instruments. <i>Processing and recording data and information:</i> collect, organise, record and process information and/or data as you go.	
<b>3 Analysing and interpreting</b> When? (e.g. week 4–mid-week 5)	<i>Analysing data and information:</i> reduce large amounts of data by summarising or coding it; begin looking for trends, patterns or mathematical relationships. <i>Problem-solving:</i> evaluate the adequacy of data (relevance, accuracy, validity and reliability) from primary and/or secondary sources.	
<b>4 Communicating</b> When? (week 5–mid-week 6).	<i>Presenting your depth study:</i> use appropriate language, scientific terminology, calculations, diagrams, graphing and other models of representation; acknowledge your sources.	
<b>5 Final presentation</b>	Due date: end of week 6	
DATA COLLECTION		
Note that what you submit in your final depth study may be different from your initial planning list.		
<b>a Action – independent variable</b> Describe what you will change in your investigation.	<b>b Outcome – dependent variable</b> What will you measure and how will you measure it? (Quantitative/qualitative data?)	<b>c Validity – controlled variable</b> What will you need to keep constant to make this a fair test? What control(s) will you use (if applicable)?
DATA ANALYSIS AND PROBLEM-SOLVING		
<b>a Data analysis</b> What method(s) will you use to analyse the data and how will you represent the trends and patterns?	<b>b Conclusion</b> How will you judge whether the experiment was valid? How will your data allow you to test your hypothesis or answer your question?	

## Working safely – risk assessment



Ethical understanding



Personal and social capability

You may be required to complete a risk assessment before you begin your investigation. You need to think about three things:

- ▶ *What are the possible risks* to you, to other people, to the environment or property?
- ▶ *How likely is it* that there will be an injury or damage?
- ▶ If there is an injury or damage to property or environment, *how serious are the consequences* likely to be?

A ‘risk matrix’, such as Table 1.4, can be used to assess the severity of a risk associated with an investigation. The consequences are listed across the top from negligible to catastrophic. Negligible may be getting clothes dirty. Catastrophic would be a death or the release of a toxin into the environment. When considering the risks involved with chemicals, read the safety data sheet for each chemical used or produced. These are readily available on the Internet. You need to ensure that your investigation is low risk.

**TABLE 1.4** Risk matrix for assessing for severity of risk

CONSEQUENCES→ LIKELIHOOD↓	NEGLECTIBLE	MARGINAL	SEVERE	CATASTROPHIC
Rare	Low risk	Low risk	Moderate risk	High risk
Unlikely	Low risk	Low risk	High risk	Extreme risk
Possible	Low risk	Moderate risk	Extreme risk	Extreme risk
Likely	Moderate risk	High risk	Extreme risk	Extreme risk
Certain	Moderate risk	High risk	Extreme risk	Extreme risk

Once you have considered the possible risks, you need to think about what you will do about them. What will you do to minimise them and how will you deal with the consequences if something does happen? You can use a risk assessment table such as in Table 1.5.

**TABLE 1.5** Example risk assessment table for managing risks

WHAT ARE THE RISKS IN DOING THIS INVESTIGATION?	HOW CAN YOU MANAGE THESE RISKS TO STAY SAFE?
2 mol L <sup>-1</sup> HCl is corrosive to skin and clothes.	Clean up all spills immediately. Wear safety glasses and wash hands after handling the chemical.

mol/L and mol L<sup>-1</sup> have the same meaning (mol per litre) and can be used interchangeably

- In primary source investigations you collect and analyse your own data. In secondary source investigations you analyse someone else’s data.
- Investigations need to be carefully planned so that they answer your research question. You also need to consider safety and possible environmental impacts of your investigation.

## 1.4 Conducting your investigation



Literacy



Numeracy



Information and communication technology capability

If you have planned carefully and learnt how to use the equipment, then your experiments should go smoothly.

Always record data immediately, with the correct units and with their uncertainty. Your **raw data** should always be recorded directly into your logbook. Data collected using a data logger should be downloaded and added to your logbook, including referencing details to the electronic file for future use.

If you are going to be collecting multiple data points, then it is a good idea to draw a table to record them in. Label the columns in the table with the name and units of the variables. If you know that the uncertainty in all your measurements is the same, then you can record this at the top of the column as well. Otherwise, each data entry should have its uncertainty recorded in the cell with it.

It is a good idea to start your analysis while you are collecting your data. If you spot an **outlier** and you are still making measurements then you have the opportunity to repeat that measurement. If you make a mistake, then put a line through the mistake, write in the new data, and make a comment in your logbook.

If you have not made a mistake, then plotting and analysing as you go allows you to spot something interesting early on. You then have a choice between revising your hypothesis or question to follow this new discovery, or continuing with your plan. Many investigations start with one question and end up answering a completely different one. These are often the most fun, because they involve something new, exciting and sometimes unexpected.

## Estimating uncertainties

When you perform experiments, there are typically several sources of uncertainty in your data.

- Sources of uncertainty that you need to consider are the:
  - limit of reading of the measuring devices
  - precision of measuring devices
  - variation of the **measurand** (the variable being measured).

For *all* devices there is an uncertainty due to the limit of reading of the device. The limit of reading is different for analogue and digital devices.

Analogue devices, such as liquid in glass thermometers, have continuous scales. For an analogue device, the **limit of reading**, sometimes called the resolution, is half the smallest division on the scale. You take it as half the smallest division because you will generally be able to see which division mark the indicator (needle, fluid level, etc.) is closest to. So, for a liquid in a glass thermometer with a scale marked in degrees Celsius, the limit of reading is  $0.5^{\circ}\text{C}$ .

Digital devices, such as digital thermometers and stopwatches, have a scale that gives you a number. A digital device has a limit of reading uncertainty of a whole division. So, a digital thermometer that reads to a whole degree has an uncertainty of  $1^{\circ}\text{C}$ . For a digital device, the limit of reading is *always* a whole division, not a half, because you do not know whether it rounds up or down, or at what point it rounds.

- The limit of reading or resolution is the *minimum* uncertainty in any measurement. Usually the uncertainty is greater than this minimum.

The measuring device used will have a **precision**, usually given in the user manual. For example, a pH meter (which indicates acidity or alkalinity), such as that shown in Figure 1.7a (page 14), may have a precision of 0.5% on a pH scale. This means if you measure a pH of 12.55 on this scale, the uncertainty due to the precision of the meter is  $0.005 \times 12.55 = 0.06$ . This is greater than the limit of reading uncertainty, which is 0.01 in this case.

- Many students think that digital devices are more precise than analogue devices. This is often not the case. A digital device may be easier for you to read, but *this does not mean it is more precise*. The uncertainty due to the limited precision of the device is generally greater than the limit of reading.



Function	Precision
pH range	0.00 to 14.00 pH
Resolution	0.01 pH
Accuracy	± 0.01 pH
pH slope range	80 to 120%
No. of calibration points	1 to 3 points (push-button)
Buffer options	pH 401 700 1001 (USA) pH 401 686 918 (NIST) pH 410 697 (Pb)
Temperature range	00 to 10.0 °C
Resolution	0.1 °C
Accuracy	± 0.5°C
Temperature comp.	Automatic/Manual (0 to 100 °C)

**FIGURE 1.7** a A typical small pH meter; b a page from the user manual giving the precision on various scales

Finally, the measurand itself may vary. For example, reaction rate is strongly dependent on the temperature, concentration and other factors. Even keeping the conditions as close to identical as possible, it is unlikely that repeat experiments will give you exactly the same results. Making repeat measurements allows you to estimate the size of the variation.

Sometimes you will be able to see how the measurand varies during a measurement by watching a needle move or the readings change on a digital device. Watch and record the maximum and minimum values. The difference between the maximum and minimum value is the range:

$$\text{Range} = \text{maximum value} - \text{minimum value}$$

The value of the measurand is the average value for repeated measurements, or the centre of the range for a single varying measurement:

$$\text{Measurand} = \text{minimum value} + \frac{1}{2} (\text{range})$$

The uncertainty in the measurement is half the range:

$$\text{Uncertainty} = \frac{1}{2} (\text{range}) = \frac{1}{2} (\text{maximum value} - \text{minimum value})$$

For example, if you are using an analogue multimeter and you observe that the reading fluctuates between 12.2 and 12.6V then your measurement should be recorded as  $(12.4 \pm 0.2)V$ . Note that the measurement and uncertainty are together in the brackets, indicating that the unit applies to both the measurement and its uncertainty.

When you take repeat measurements, the best estimate of the measurand is the average value. If you have taken fewer than ten measurements then the best estimate of the uncertainty is half the range. If you have more than ten measurements, the best estimate of the uncertainty is the standard deviation, given by:

$$\text{Standard deviation} = \left( \frac{\sum (x_i - \bar{x})^2}{n - 1} \right)^{\frac{1}{2}}$$

where  $x_i$  is an individual value of the measurand,  $\bar{x}$  is the average value of the measurand and  $n$  is the total number of measurements. The sum is over all values of  $x_i$ . Most calculators and spreadsheet software have built-in statistical functions to make calculations such as standard deviation. Remember that repeat measurements means repeating under the same conditions. It is not the same as collecting lots of data points under different conditions.

  
**Guide to the  
 expression of  
 uncertainty in  
 measurement**  
 Read more about  
 uncertainties.

Sources of uncertainty all give rise to random errors. That means that repeated measurements will be randomly spread about the 'true value', and centred on that value. This is why many measurements are repeated and averages are taken.

**Systematic errors** can also occur. These include calibration errors on measuring devices and parallax errors during observations. Sources of systematic errors must be considered during the planning phase and actions taken to ensure that they are avoided when performing the investigation.

- The uncertainty in any measurement depends upon the limit of reading of the measuring device, the precision of the device and the variation of the measurand.

## 1.5 Analysing data

Once you have collected your data, you will need to analyse it. Record all of your analyses in your logbook.

The first step in analysing data, whether primary or secondary, is organising it. This will usually involve tabulating it. Tables of data need to have headings with units for each column, and a caption telling you what the data means, or how it was collected. Tables are used for recording raw data, and also for organising **derived data**.

- Raw data is the data that you collected during your investigation.
- Derived data is any data that you have calculated from the original data that you collected during the investigation.



### Performing calculations with your data

You will usually have to do some calculations with your data as part of your analysis. When you recorded your data, you wrote down the units for all of your measurements as well as the uncertainties. You may need to convert the units and the uncertainties to SI units (International System of Units); for example, mL to L. Include the units with all numbers as you do your calculations. This will ensure that you have the correct units on all derived data.

Significant figures are also important when performing calculations with your data. Refer to the appendix for general information on significant figures, including adding and subtracting significant figures.

When performing calculations involving concentrations of solutions and pH, the number of decimal places reported in the pH is equal to the number of significant figures in the concentration of the solution. For example:

A hydrochloric acid solution has a pH = 5.43 (this measurement is reported to two decimal places):

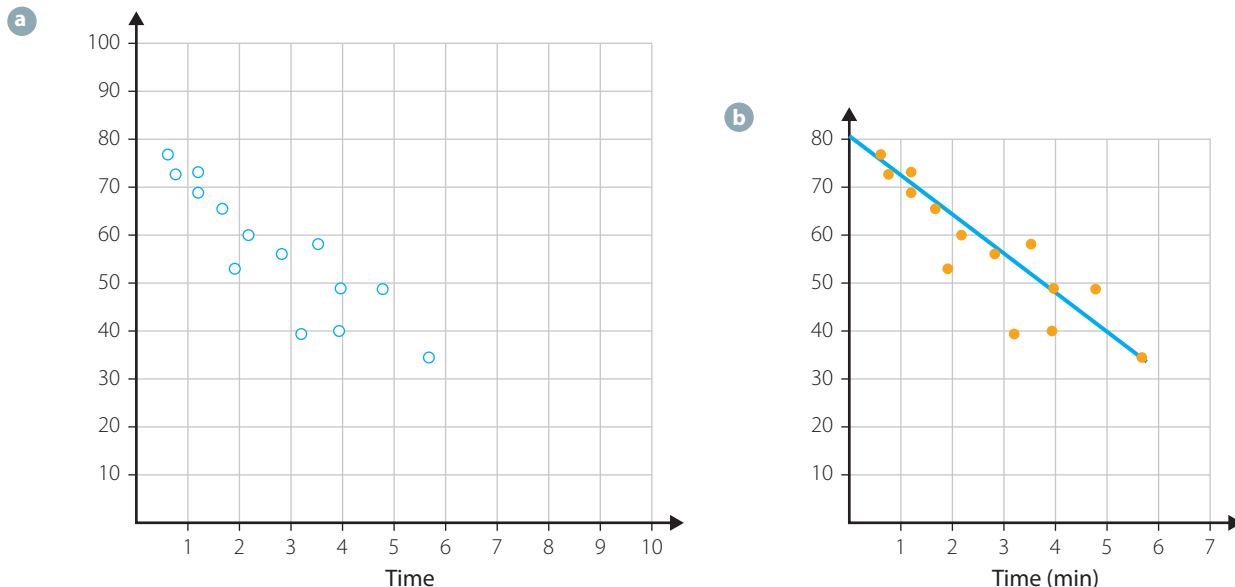
$$\text{Concentration of HCl} = 10^{-\text{pH}} = 10^{-5.43} = 0.00000371535$$

Since the pH is reported to two decimal places, the concentration of HCl must be reported to two significant figures (i.e.  $3.7 \times 10^{-6} \text{ mol L}^{-1}$ ).

### Identifying trends, patterns and relationships

You may be able to see a pattern simply by looking at a list of numbers in a table. However, it is usually easier to see a pattern in data or a relationship between variables by using a graph. This is especially useful if you are trying to quantify a relationship. For example, is it a linear relationship or an exponential relationship?

Graphs should be large and clear. The axes should be labelled with the names of the variables and their units. The independent variable should be on the  $x$  axis, while the dependent variable should be on the  $y$  axis. Choose a scale so that your data takes up most of the plot area. This will often mean that the origin is not shown in your graph and usually there is no reason why it should be. Figure 1.8 shows a good example of a graph and a poor example of a graph.



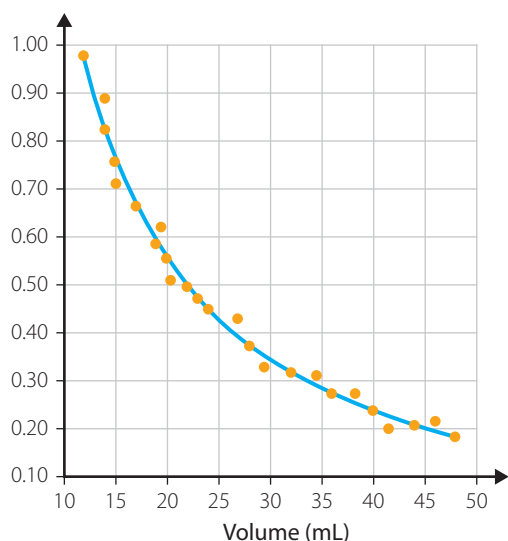
**FIGURE 1.8** **a** A poor example of a graph; **b** a good example of a graph of the same data. How many differences can you see?

When you are looking for a relationship between variables, construct a **scatter plot** (also known as a **scatter graph**). This is a graph showing your data as points. Do not join them up as in a dot-to-dot picture. To determine a relationship you need to have enough data points and the range of your data points should

be as large as possible. A minimum of six data points is generally considered adequate if the relationship is expected to be linear (giving a straight line), but always collect as many as you reasonably can, given the available time.

For non-linear relationships you need more data points than this. Try to collect more data in regions where you expect rapid variation. For example, if you are measuring the pressure of a fixed mass of gas at different volumes, as shown in Figure 1.9, then you should expect an inverse relationship and therefore a hyperbola graph. If there are only a limited number of data points, it would be easy to predict the relationship to be linear instead.

A good graph to start with is simply a graph of the raw data. You will usually be able to tell if the graph is linear. If it is, then draw a straight line of best fit either by hand or using graphing software. Graphing software has a linear regression tool that calculates an  $R^2$  number, which is a measure of 'goodness of fit'. The closer  $R^2$  is to 1 (or  $-1$ ), the better the fit. If it is not *very* close to 1, typically



**FIGURE 1.9** A pressure–volume graph for a gas needs a large number of data points to show the hyperbola shape.





**Data points**  
Some helpful advice  
on deciding the  
number of data points

better than 0.95, then the relationship is probably not linear. Alternatively, you can calculate the uncertainty in the gradient by using lines of maximum and minimum gradient. If the uncertainty is large, then the relationship may not be linear.

If it is a linear relationship, then finding the equation for the line of best fit will be useful. Remember that a linear relationship is of the form  $y = mx + c$ , where:

- $y$  is the dependent variable plotted on the vertical axis
- $x$  is the independent variable on the horizontal axis
- $m = \frac{\Delta y}{\Delta x}$  (the gradient of your graph)
- $c$  is the  $y$  intercept from your graph.

*Never* force a line of best fit through the origin. The intercept gives you useful information. It may even indicate a systematic error, such as a zero error in calibration of your equipment.

When you plot your raw data, you may find that one or two points are outliers. These are points that do not fit the pattern of the rest of the data. These points may be mistakes; for example, they may have been incorrectly recorded or a mistake was made during measurement. They may also be telling you something important. For example, if they occur at extreme values of the independent variable then it might be that the behaviour of the system is linear in a certain range only. You may choose to ignore outliers when fitting a line to your data, but you should be able to justify why.

Extrapolation is when you extend a line of best fit beyond your measured points. You must be cautious in how you treat extrapolated data since you do not have any evidence that the system continues to behave in the same way outside the range of your measured data points.

Interpolation is where you use data points from your line of best fit that were not your original measured data. If your line of best fit matches your data points well, then you would have reasonable confidence in the validity of these interpolated data. Hence, you can use interpolated data in your analysis.

Relationships between variables are often not linear. If you plot your raw data (for instance the volume and pressure of a gas) and it is a curve, then *do not draw a straight line through it*. In this case you need to think a little harder. If your hypothesis predicts the shape of the curve, then try fitting a theoretical curve to your data. If it fits well, then your hypothesis is supported.

Sometimes the relationship between variables will be more complicated than a linear relationship. In this case, a graph is still useful, but the most you might be able to give is a descriptive relationship; for example, one variable increases with another, or that there is a peak at a particular position. A graph is still a useful way of identifying trends and patterns, even if you are not able to extract a mathematical relationship from the graph.

## Interpreting your results

Once you have analysed your results, you need to interpret them. This means being able to either answer your research question or state whether your results support your hypothesis.

If your hypothesis is not supported, it is not enough to simply say 'our hypothesis is wrong'. If the hypothesis is wrong, *what* is wrong with it?

Go through your method, results and analysis. Check that your equipment was calibrated, and that you were using it correctly. Check that all data has been recorded in the correct units, and that all units have been correctly carried through all calculations during analysis. Check your analysis carefully.

You should also consider whether other factors may have affected your results. Were there variables that you weren't able to control? Were there variables that you forgot to control?

Experiments that do not support predictions based on existing models are crucial in the progress of science. It is these experiments that tell us that there is more to find out, and inspire our curiosity as scientists.

- It is never good enough to conclude that 'the experiment didn't work'. Either a mistake was made or the model used was not appropriate for the situation. It is your job to work out which.
- You must know the uncertainty in your results to be able to test your hypothesis.

## 1.6 Communicating your understanding



If research is not reported on, then no-one else can learn from it. An investigation is not complete until the results have been communicated. Most commonly a report is written. However, scientists may communicate their research in other ways, such as through posters, demonstrations, public lectures, websites, videos and blogs (Figure 1.10). All of these are useful ways of communicating your understanding too, and you need to select the mode that best suits the content you wish to communicate and the audience to whom you wish to communicate with. Think about your audience and purpose and use appropriate language and style.

A poster is not usually as formal as a report. A video or web page may be more or less formal, depending on your audience.

Posters and websites use a lot of images. Images are usually more appealing than words and numbers, but they need to be relevant. Make sure they communicate the information you want them to.

**FIGURE 1.10**

A poster session is a common way to present scientific findings at a conference.



Consider accessibility if you are creating a website. Fonts need to be large enough and clear on websites and digital images should have tags. You can follow the weblink for more information on accessibility and web page design.

### Writing reports

A report is a formal and carefully structured account of your investigation or depth study. It is based on the data and analysis in your logbook. However, the report is a *summary*. It contains only a small fraction of what appears in the logbook. Your logbook contains all your ideas, rough working and raw data. The report typically contains almost none of this.



- A report consists of several distinct sections, each with a particular purpose.
  - Abstract
  - Introduction
  - Method
  - Results and analysis
  - Discussion
  - Conclusion
  - Acknowledgements
  - References
  - Appendices

Reports are always written in the past tense, because they describe what you have done.

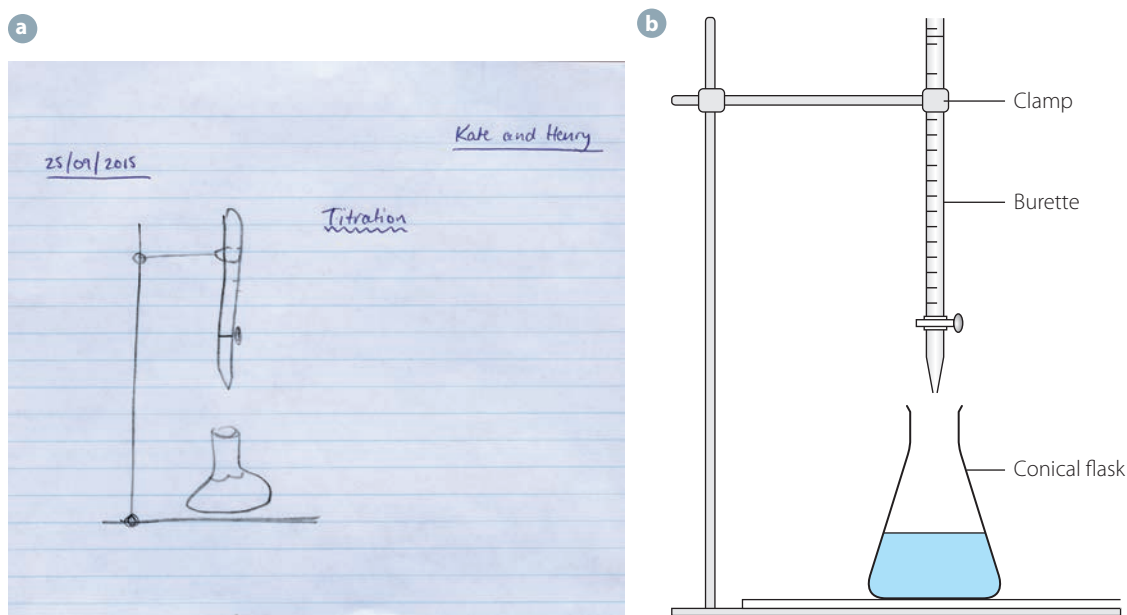
The abstract is a very short summary of the entire report, typically between 50 and 200 words long. It appears at the start of the report, but is always the last thing that you write. Try writing just one sentence to summarise each part of your report.

The introduction tells the reader why you did the investigation or depth study and what your research question or hypothesis was. This is the place to explain why the research is interesting.

The introduction also includes the literature review, which gives the background information needed to be able to understand the rest of the report. The introduction for a secondary source report is similar to that for a primary source investigation. In either case, it is important to reference all your sources correctly.

The method summarises what you did. It says what you measured and how you measured it. It is not a recipe for someone else to follow. It also explains briefly why you chose a particular method or technique.

For a primary source investigation, the method describes how you carried out your experiments or observations in enough detail that someone with a similar knowledge level could repeat your experiments. It should include large, clear diagrams of equipment set-up, circuits, etc. You should have diagrams in your logbook, but these are generally rough sketches. Diagrams should be redrawn neatly for a report, as in Figure 1.11.



**FIGURE 1.11** a A sketch of a titration from a logbook; b a scientific illustration for a report

The method section for a secondary source investigation is generally shorter. If you are doing a review of the current literature on a topic then your method will say what literature searches you carried out, and how you decided which sources to use.

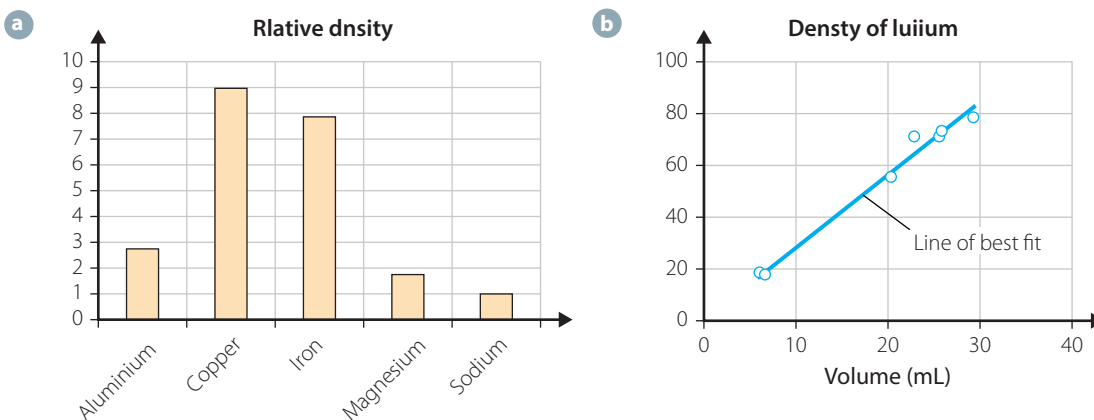
The results section is a *summary* of your results. It is usually combined with the analysis section, although they may be kept separate.

Tables comparing the results of different experiments or secondary sources are useful. But avoid including long tables of raw data in your report. If you need to include a lot of raw data, then put it in an appendix attached to the end of the report.

Wherever possible, use a graph instead of a table. However, your graph should be for the averages, not all the raw data. Think about what sort of graph is appropriate. If you want to show a relationship between two variables, then use a scatter graph. Display your data as points and clearly label any lines you have fitted to the data.

Column graphs are useful for comparing two data sets, such as the average time taken for 5g of calcium carbonate chips and powder to react. *Do not* use a column graph to try to show a mathematical relationship between variables.

Examples of these two types of graphs are shown in Figure 1.12.



**FIGURE 1.12** **a** A column graph can be used for discrete data; **b** a scatter graph is used to show a mathematical relationship between continuous data.

Any data and derived results should be given in correct SI units with their uncertainties. If you performed calculations, then show the equations you used. You might want to show one example calculation, but do not show more than one if the procedure used is repeated.

The discussion should summarise *what your results mean*. If you began with a research question, give the answer to the question here. If you began with a hypothesis, state whether or not your results supported your hypothesis. If not, explain why. If your investigation led you to more questions, as is often the case, say what further work could be done to answer those questions.

The conclusion is a *very* brief summary of the results and their implications. Say what you found out and what it means. A conclusion should only be a few sentences long.

Scientific reports often include acknowledgements thanking people and organisations that helped with the investigation. This includes people who supplied equipment or funding, as well as people who gave you good ideas or helped with the analysis. In science, as in other aspects of your life, it is always polite to say thank you.

The final section of a report is the reference list. It details the sources of all information that were used to write the report. This will generally be longer for a secondary source investigation. Wherever a piece of information or quotation is used in your report it must be referenced *at that point*. This is typically done either by placing a number in brackets at the point, such as '[2]', or the author and year of publication, such as '(Jones, 2014)'. The reference list is then either provided in a footnote at the end of each page, or as a single complete list at the end of the report. There are different formats for referencing, so check with your teacher what format they prefer. There are several good online guides to referencing.

Note that a reference list is *not* the same as a bibliography. A bibliography is a list of sources that are useful to understanding the research. They may or may not have actually been used in the report. You should have a bibliography in your logbook from the planning stage of your investigation. The references will be a subset of these sources. A primary source investigation does not include a bibliography. A secondary source investigation may include a bibliography as well as references, to demonstrate the scope of your literature search. For some secondary source investigations, such as an annotated bibliography, the bibliography itself may be a major section of the report.

- A formal report has the same form as an article written by a scientist. It begins with an abstract briefly summarising the entire work. It includes an introduction with a literature review, a risk assessment, method, results and analysis, discussion and conclusion. All sources need to be referenced correctly.



#### Referencing guide

This guide is designed to help you with referencing your sources.



#### Referencing i-tutorial

This tutorial will help you understand referencing and show you how to avoid plagiarism.

## 1.7 Ideas for depth studies

Throughout this book, there are suggestions for investigations in each chapter. Some of these investigations are described in detail. These investigations are designed to be useful as training exercises in learning how to perform primary investigations – how to set up equipment, make measurements, and analyse data. There are also examples of less detailed suggestions for investigations. Those investigations are there to give you ideas of how you could carry out a primary investigation. Even if your depth study is secondary source, it is important to gain some experience of doing experiments since chemistry is based on experiment.

At the end of each module there is a short section called *Depth study suggestions*. Here you will find ideas for primary and secondary source investigations, which build on the content of the preceding module. Your own teacher will also have ideas and suggestions. You can also generate your own ideas by reading about topics you are interested in. Consider what skills from other areas you might bring to a depth study, particularly if you are artistically creative or musical.

By carrying out depth studies, you will extend your knowledge and understanding in chemistry, but more importantly, you will learn how to work scientifically – you will learn how to *do* chemistry.

# 1 CHAPTER SUMMARY

## IMPORTANT NEW TERMS

After studying this chapter you should know the meaning of the following terms:

accurate (p. 11)

controlled variable (p. 8)

dependent variable (p. 8)

depth study (p. 2)

derived data (p. 15)

empirical (p. 2)

falsifiable (p. 2)

hypothesis (p. 3)

independent variable (p. 8)

limit of reading (p. 13)

literature review (p. 7)

logbook (p. 6)

measurand (p. 13)

model (p. 4)

outlier (p. 13)

precision (p. 13)

primary source data/investigation (p. 5)

raw data (p. 12)

reliable (p. 10)

reproducible (p. 10)

research question (p. 7)

scatter plot/graph (p. 16)

scientific method (p. 3)

secondary source data/investigation (p. 5)

systematic error (p. 15)

uncertainty (p. 10)

valid (p. 3)



# EQUILIBRIUM AND ACID REACTIONS

- ② Qualitative equilibrium
- ③ Calculating the equilibrium constant
- ④ Solution equilibria



## 2

## Qualitative equilibrium

## INQUIRY QUESTION

What happens when chemical reactions do not go through to completion?

## INQUIRY QUESTION

What factors affect equilibrium and how?

## Students:

conduct practical investigations to analyse the reversibility of chemical reactions, for example:

- cobalt(II) chloride hydrated and dehydrated
- iron(III) nitrate and potassium thiocyanate
- burning magnesium
- burning steel wool (ACSCH09) ICT

model static and dynamic equilibrium and analyse the differences between open and closed systems (ACSCH07, ACSCH91)

analyse examples of non-equilibrium systems in terms of the effect of entropy and enthalpy, for example:

- combustion reactions
- photosynthesis

investigate the relationship between collision theory and reaction rate in order to analyse chemical equilibrium reactions (ACSCH07, ACSCH94) ICT

investigate the effects of temperature, concentration, volume and/or pressure on a system at equilibrium and explain how Le Chatelier's principle can be used to predict such effects, for example:

- heating cobalt(II) chloride hydrate
- interaction between nitrogen dioxide and dinitrogen tetroxide
- iron(III) thiocyanate and varying concentration of ions (ACSCH09)

explain the overall observations about equilibrium in terms of the collision theory (ACSCH09)

examine how activation energy and heat of reaction affect the position of equilibrium.

Chemistry Stage 6 Syllabus © NSW Educational Standards Authority for and on behalf of the Crown in right of the State of New South Wales, 2017





Prior knowledge

In our everyday lives there are many examples of balance or **equilibrium**. A see-saw is in equilibrium when the forces on either side are balanced and the see-saw remains horizontal. Water in a rainforest is in equilibrium when the amount of rainfall balances the amount of evaporation and use. A person's weight is in equilibrium when the amount of energy from the food eaten balances the amount of energy used. Similarly, in chemistry, some reactions achieve a balance where the amount of reactants and products remain constant and the chemical system is in equilibrium. When these processes are occurring equally, they are balanced and equilibrium is achieved.

The term 'equilibrium' always refers to a balance. However, in different contexts the exact meaning may vary. Therefore, it is important that you understand the requirements and processes for chemical equilibrium.

The chemical reactions that you've observed to date have been simple one-direction reactions where you started with reactants and ended, when one of the reactants was completely used up, with the products. However, a significant number of chemical reactions can be manipulated to form more products or more reactants.



**FIGURE 2.1** A see-saw can represent equilibrium.

## 2.1 Non-equilibrium systems

In *Chemistry in Focus Year 11*, chapter 16, you learnt about the importance of the two major drives, **enthalpy** and **entropy**, in determining whether a chemical reaction would occur **spontaneously** or not. In summary:

- ▶ A reaction will favour the movement towards greater randomness. This is indicated by a positive change in entropy ( $\Delta S$ ).
- ▶ A reaction will be favoured if it releases heat energy. This is indicated by a negative change in enthalpy ( $\Delta H$ ).

Hence, if:

- ▶ the reaction favours the movement towards greater randomness and it also releases heat energy (that is, it has a positive entropy change and a negative enthalpy change), then the reaction will occur spontaneously. It will continue to occur until one of the reactants is completely used up. Then it will stop and there will be no further reaction.
- ▶ the reaction does not favour the movement towards greater randomness and it also requires the continual input of heat energy (that is, it has a negative entropy change and a positive enthalpy change), then the reaction will not occur spontaneously. It will not react. However, it will occur spontaneously in the reverse direction.

It is more difficult to determine whether a reaction will occur spontaneously if the drivers are opposing each other; for example:

- the reaction favours the movement towards greater randomness and it requires the continual input of heat energy (that is, it has a positive entropy change and a positive enthalpy change)
- the reaction does not favour the movement towards greater randomness and it releases heat energy (that is, it has a negative entropy change and a negative enthalpy change).

Which driver has the greater effect? It is the combination of these factors that overall determines whether the reaction will occur spontaneously or not. The Gibbs free energy ( $\Delta G$ ) is the quantity that analyses the effects of these drivers to determine whether the reaction will occur spontaneously or not at a given temperature ( $T$ ). It is stated as:

$$\Delta G = \Delta H - T\Delta S$$

When  $\Delta G$  is:

- negative, the reaction will occur spontaneously
- positive, the reaction will not occur spontaneously.

## WORKED EXAMPLE 2.1

Determine whether the following reaction is spontaneous or not at 298 K.



Data: (under standard conditions, i.e. at 298 K)



SPECIES	CH <sub>4</sub> (g)	O <sub>2</sub> (g)	CO <sub>2</sub> (g)	H <sub>2</sub> O(l)
ENTHALPY OF FORMATION (kJ mol <sup>-1</sup> )	-75	0	-393	-285
ENTROPY (J K <sup>-1</sup> mol <sup>-1</sup> )	+186	+205	+214	+70

ANSWER	LOGIC
$\Delta H = \Sigma\Delta H_f(\text{products}) - \Sigma\Delta H_f(\text{reactants})$ $\Delta H = [-393 + (2 \times -285)] - [-75] = -888 \text{ kJ}$	<ul style="list-style-type: none"> <li>Calculate the enthalpy for the reaction.</li> </ul>
$\Delta S = \Sigma\Delta S(\text{products}) - \Sigma\Delta S(\text{reactants})$ $\Delta S = [+214 + (2 \times +70)] - [+186 + (2 \times 205)] = -242 \text{ J K}^{-1} \text{ mol}^{-1}$	<ul style="list-style-type: none"> <li>Calculate the entropy for the reaction.</li> </ul>
$\Delta G = \Delta H - T\Delta S$ $\Delta G = -888 - (298 \times -242 \times 10^{-3}) = -888 + 72 = -816 \text{ kJ mol}^{-1}$	<ul style="list-style-type: none"> <li>Calculate the Gibbs free energy – remember to convert entropy to kJ.</li> </ul>
The reaction is spontaneous because the Gibbs free energy is negative.	<ul style="list-style-type: none"> <li>Refer back to question and answer in format required.</li> </ul>

### TRY THIS YOURSELF

Determine whether the following reactions are spontaneous or not at 298 K.

- Combustion of octane:  $2\text{C}_8\text{H}_{18}(\text{l}) + 25\text{O}_2(\text{g}) \rightarrow 16\text{CO}_2(\text{g}) + 18\text{H}_2\text{O}(\text{l})$
- Photosynthesis:  $6\text{CO}_2(\text{g}) + 6\text{H}_2\text{O}(\text{l}) \rightarrow \text{C}_6\text{H}_{12}\text{O}_6(\text{s}) + 6\text{O}_2(\text{g})$

Extra data: (under standard conditions, i.e. at 298 K)

SPECIES	C <sub>8</sub> H <sub>18</sub> (l)	C <sub>6</sub> H <sub>12</sub> O <sub>6</sub> (s)
ENTHALPY OF FORMATION (kJ mol <sup>-1</sup> )	-250	-1273
ENTROPY (J K <sup>-1</sup> mol <sup>-1</sup> )	+361	+212





**FIGURE 2.2** Gas cooking involves combustion reactions: **a** a barbeque and **b** a gas stove.

Determining the Gibbs free energy allows us to determine whether the reaction will occur spontaneously or not. From Worked example 2.1, the Gibbs free energy indicates that combustion reactions are spontaneous at standard room temperature (298 K). A small amount of energy is added to initiate the reaction, and once combustion reactions start, they will continue until one of the reactants has been completely used up. Two familiar combustion reactions are shown in Figure 2.2.

However, the Gibbs free energy for the photosynthesis reaction indicates that it is not a spontaneous reaction. It will only occur when a significant amount of energy is supplied or a catalyst is used with a lesser amount of energy being supplied. Photosynthesis occurs in green plants because they have chlorophyll, a necessary catalyst for this reaction to occur. Photosynthesis also only occurs during the day when the UV energy from the sun is readily available.

The reactants and products of respiration are the reverse of those of photosynthesis. Respiration is the combustion reaction of glucose. Hence, the Gibbs free energy for respiration is negative, so it will occur spontaneously. This reaction occurs every day in our bodies to provide the energy we need to live.

However, sometimes the thermochemical data is not as straightforward as it was for the above examples. What happens when the change in Gibbs free energy for a reaction is very close to zero?

Remember, when  $\Delta G$  is:

- ▶ negative, the reaction will occur spontaneously
- ▶ positive, the reaction will not occur spontaneously (however, the reverse reaction would occur spontaneously).

So, when  $\Delta G$  for a reaction is very close to zero, it would indicate that the reactants could form products, while at the same time the products could react to form the reactants. Hence, there are two reactions occurring at the same time when all species are present.

## 2.2 Reversible reactions

If a car is put in reverse, it will go backwards. Therefore, the term **reversible reaction** must mean a reaction that is able to go backwards. But how is that so? Surely the reactants must form the products. They do, but sometimes the products can form the reactants.



**FIGURE 2.3** A closed system does not allow chemicals to enter or leave.

### Chemical systems

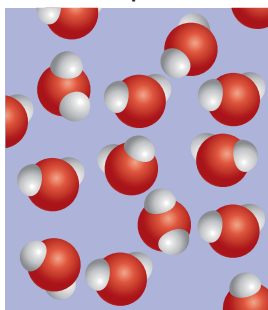
The chemicals involved in a reaction form the **chemical system**, while anything around these chemicals but not involved in the actual reaction forms the **surroundings**. For example, in the reaction between hydrogen gas and oxygen gas to form water vapour, the molecules of hydrogen, oxygen and water make up the system, while the other molecules in the air (for example, nitrogen, carbon dioxide) form the surroundings. In an aqueous environment, the water will form part of the system if it is involved in the reaction and it will form the surroundings if it is not involved (Figure 2.3).

If the chemicals in the reaction are all contained within a certain space, this is called a **closed system**. For example, if hydrochloric acid was added to calcium carbonate in a sealed container, then nothing can enter or leave the system and it is described as a closed system.

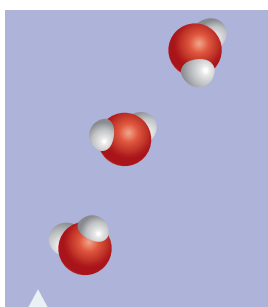
Conversely, if substances can either be added or lost, then this is described as an **open system**. For example, if hydrochloric acid is added to calcium carbonate in an open beaker, then the carbon dioxide gas produced would escape into the air. Therefore, this is an open system.

When referring to an open or closed system, it is referring to whether matter can either enter or leave or not. In both situations, energy is able to enter and leave the system.

Liquid



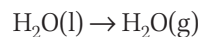
Gas



**FIGURE 2.4** Water boiling is a physical change.

### Physical and chemical changes

The change that occurs in a chemical system can be described as a **physical change** or a **chemical change**. During a physical change, the products do not include any new substances. Instead, the physical properties of the reactant change, which can include a change of state. For example, when water is boiled, it changes from a liquid to a gas (Figure 2.4). The molecules remain the same; they are simply further apart. This change can be represented by the equation:

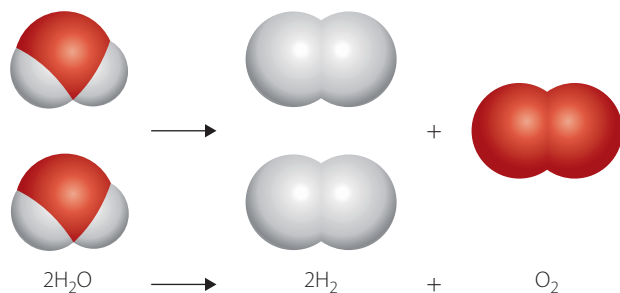


During a chemical change, the reactants produce new substances with different physical and chemical properties from those of the original substances. For this to happen, the atoms rearrange and form products that are different from the reactants. An example of a chemical change occurs when an electric current is passed through water. The atoms in the reactant (water) rearrange to form the new substances of oxygen gas and hydrogen gas:



Figure 2.5 shows this reaction.



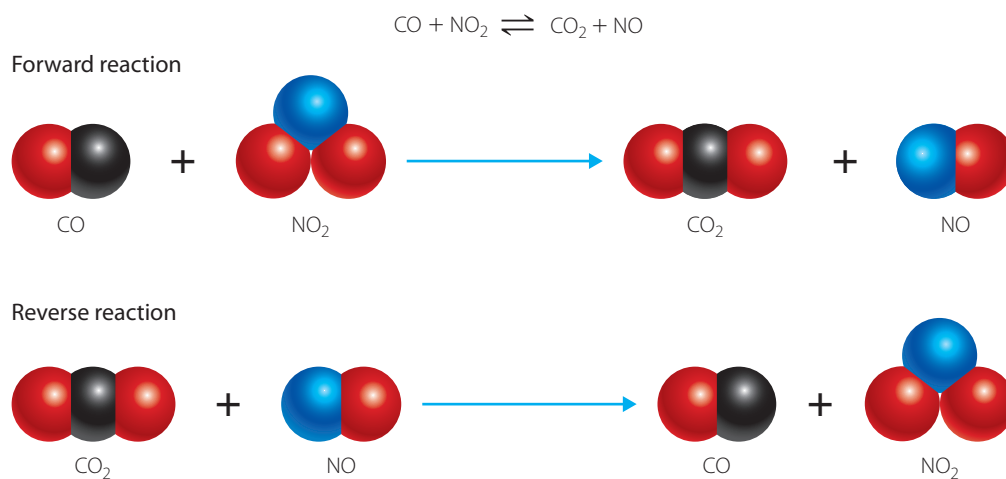


**FIGURE 2.5** The electrolysis of water is a chemical change.

## Reversible reactions

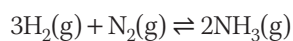
When you consider chemical reactions, you often think of a situation where the reaction occurs in one direction and the reactants continue to produce the products until one of the reactants is used up and the reaction stops. This is **static equilibrium**. In reality, this only happens for some reactions. In other reactions, as the products are formed, some of them will react to become reactants again. This means that when the reaction appears 'complete', there are both reactants and products present. This is **dynamic equilibrium**.

Reactions where the reactants are able to form products and the products form reactants are known as reversible reactions. All physical changes are reversible reactions. However, only some chemical changes are reversible. The reaction where the reactants form products is called the **forward reaction** and the reaction where the products form reactants is called the **reverse reaction**. Figure 2.6 shows the reversible reaction that occurs when carbon monoxide reacts with nitrogen dioxide.



**FIGURE 2.6** Forward and reverse reactions

The reaction between hydrogen gas and nitrogen gas is also a reversible reaction and can be represented by the equation:



A double arrow is used to show that the reaction can occur in both directions. In this example, hydrogen gas and nitrogen gas forming ammonia is the forward reaction. Ammonia decomposing to form hydrogen gas and nitrogen gas is the reverse reaction.

## INVESTIGATION 2.1



Information and  
communication  
technology  
capability

### Analysing the reversibility of chemical reactions

#### INTRODUCTION

Some chemical reactions are able to be reversed, while others are not. In this investigation, you will observe a number of chemical reactions and justify whether they are reversible or not. You may wish to record your results using words or photos.

#### AIM

To observe several chemical reactions and determine whether they are reversible or not.

#### MATERIALS

- 25 mL dropper bottle of  $1 \text{ mol L}^{-1}$  cobalt(II) chloride hexahydrate
- 25 mL dropper bottle of  $0.05 \text{ mol L}^{-1}$  potassium chromate
- 25 mL dropper bottle of  $0.05 \text{ mol L}^{-1}$  potassium dichromate
- 25 mL dropper bottle of  $0.1 \text{ mol L}^{-1}$  hydrochloric acid
- 25 mL dropper bottle of  $0.1 \text{ mol L}^{-1}$  sodium hydroxide
- 1 × 5 cm piece of magnesium ribbon
- Distilled water
- 1 piece of filter paper (55 mm × 55 mm)
- 3 watch glasses
- 1 drying oven/incubator
- 4 test tubes
- Test-tube rack
- 4 small labels
- 1 pair brass tongs
- 1 × (5 cm × 5 cm) piece of sandpaper
- 1 × (5 cm × 5 cm) piece of steel wool
- Gas lighter
- Dropper
- Video camera
- Safety glasses and gloves

#### MATERIALS (FOR ALTERNATIVE METHOD)

- Specimen jar containing copper sulfate
- Distilled water
- Spatula
- Test tube
- Test-tube rack
- Heat-proof mat
- Bunsen burner
- Matches





WHAT ARE THE RISKS IN DOING THIS INVESTIGATION?	HOW CAN YOU MANAGE THESE RISKS TO STAY SAFE?
Cobalt(II) chloride hexahydrate is toxic to humans and wildlife.	Be extremely careful when using this chemical. Use the dropper to transfer the solution from the bottle to the filter paper. Use brass tongs to pick up the filter paper.
Potassium chromate and potassium dichromate are both extremely toxic to humans.	Be extremely careful when using these chemicals. Wear safety glasses and gloves. Use the dropper to transfer the solution from the bottle to the test tubes. Do not pour solutions down the sink. Pour used solutions into a waste bottle.
Magnesium ribbon produces bright white light when it burns.	Do not look directly at the magnesium when it catches alight.

What other risks are associated with your investigation? How can you manage these?

### METHOD

#### PART A

- 1 Place a piece of filter paper on a watch glass.
- 2 Add cobalt chloride drop by drop until the filter paper is covered.
- 3 Observe the colour of the filter paper.
- 4 Place the watch glass into a drying oven overnight at 35°C.
- 5 Remove the watch glass and filter paper and observe the colour of the filter paper.
- 6 Add distilled water drop by drop to the same filter paper until it is covered.
- 7 Observe the colour of the filter paper.
- 8 Repeat steps 4 and 5.

#### PART A (ALTERNATIVE METHOD)

- 1 Add two spatulas of copper sulfate to a test tube.
- 2 Observe the colour of the copper sulfate.
- 3 Heat the test tube containing the copper sulfate over a Bunsen burner for a few minutes.
- 4 Observe the colour of the copper sulfate.
- 5 Add a couple of drops of water to the copper sulfate and observe the colour of the copper sulfate.
- 6 Repeat steps 3 and 4.

#### PART B

- 1 Label four test tubes A, B, C and D.
- 2 Add about 1 mL of potassium chromate to test tubes A and B.
- 3 Add about 1 mL of potassium dichromate to test tubes C and D.
- 4 Test tubes A and C are reference solutions.
- 5 Add hydrochloric acid dropwise to test tube B until a colour change occurs.
- 6 Record your observations.
- 7 Add sodium hydroxide dropwise to test tube B until another colour change occurs.
- 8 Record observations.
- 9 Add sodium hydroxide dropwise to test tube D until a colour change occurs.
- 10 Record observations.
- 11 Add hydrochloric acid dropwise to test tube D until another colour change occurs.
- 12 Record observations.



## » PART C

- 1 Clean a 5 cm piece of magnesium with sandpaper.
- 2 Hold the piece of magnesium ribbon with a pair of brass tongs.
- 3 Light the magnesium ribbon and hold it over a watch glass. Do not look directly at the magnesium while it is alight.
- 4 Record observations.

## PART D

- 1 Hold a piece of steel wool with a pair of brass tongs.
- 2 Light the steel wool and hold it over a watch glass.
- 3 Record observations.

## RESULTS

Record observations in an appropriate form.

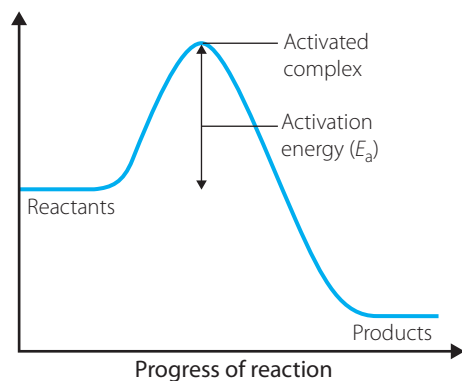
## ANALYSIS OF RESULTS

- 1 For each part, justify whether it was:
  - a a physical change or chemical change
  - b a reversible reaction or not
  - c an example of static equilibrium or dynamic equilibrium.
- 2 Write an equation to describe each of the reactions.

## Predicting reversibility

In chapter 13 of *Chemistry in Focus Year 11*, you considered collision theory to predict the rate of reactions.

**Collision theory** states that, for a reaction to occur, the particles must collide with sufficient energy to break the bonds and have the appropriate orientation to allow the new bonds to form. This theory can also be used to understand why some reactions are reversible and others are not.

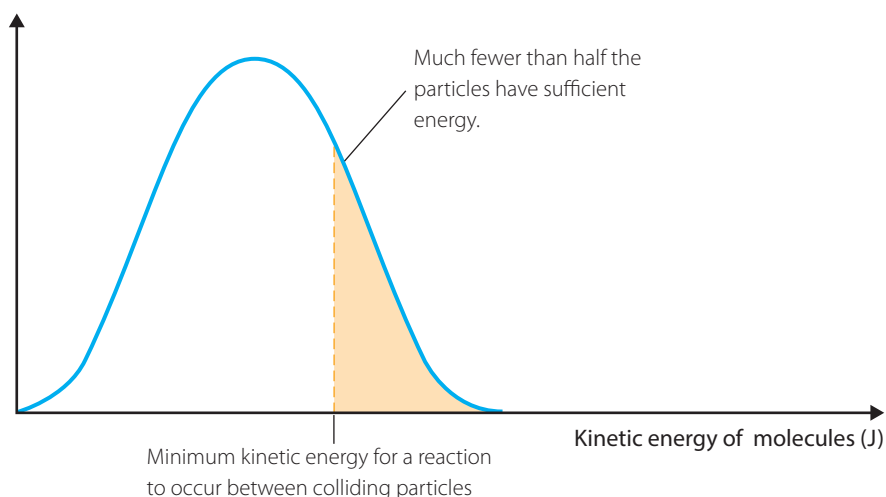


**FIGURE 2.7** Activation energy of a reaction

You will recall that the amount of energy required to break the bonds of the reactants is known as the **activation energy**. This is the difference in enthalpy between the reactants and the **activated complex**, as shown in Figure 2.7.

If the reactant particles in a collision do not have enough energy to break the bonds, then they are unable to form the products. If the activation energy is lower, then more particles will have enough energy to break the reactant bonds and form the products. Therefore, the size of the activation energy will influence the likelihood of a reaction proceeding.

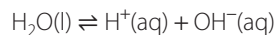
In a reaction, the activation energy of both the forward and reverse reactions is considered. If the activation energy of either of these is very high, then that reaction is unlikely to proceed because very few particles will have enough energy for a successful collision, as shown in Figure 2.8. Therefore, for a reaction to be reversible, the activation energies of both the forward and reverse reactions must be low enough that sufficient particles will have enough energy for a successful collision.



**FIGURE 2.8** The number of particles with enough energy for a successful collision

- Chemical systems may be open or closed and include physical and chemical changes, which result in observable changes.
- Some reactions only occur in one direction (that is, they are not reversible – the reactants continue to react until one of the reactants is completely used up, then the reaction stops).
- Other reactions occur in both directions (that is, they are reversible – the reactants react to form products and the products react to form reactants). When no further reaction is observed, the reactions are still occurring and there are both reactants and products present.
- All physical changes are reversible, whereas only some chemical reactions are reversible.
- The reversibility of chemical reactions is dependent on the activation energies of both the forward and reverse reactions.

- 1 State the difference between a forward and a reverse reaction.
- 2 State the requirements for a closed system.
- 3 Distinguish between static equilibrium and dynamic equilibrium.
- 4 Are all reactions reversible? Explain.
- 5 Why are double arrows used in equations for reversible reactions?
- 6 In a particular chemical reaction, if the forward reaction is exothermic, then the reverse reaction must be endothermic. Explain the reason for this.
- 7 The reaction for the self-ionisation of water is an endothermic reaction:



- a Write the equation for the forward reaction.
- b Write the equation for the reverse reaction.
- c Sketch an energy profile diagram for the forward reaction.
- d Sketch an energy profile diagram for the reverse reaction.

#### CHECK YOUR UNDERSTANDING

2.1 2.2



Critical and creative thinking



## 2.3 Dynamic equilibrium

In a closed chemical system involving a reversible reaction, as the reactants form products, the products will also form reactants. This means that the reaction will not go to completion. Rather, it will reach a state of dynamic equilibrium.

Dynamic equilibrium is a specific example of a system in a **steady state**. Systems in a steady state have constant properties. All systems at dynamic equilibrium must be in a steady state since their properties will remain constant. However, not all systems in a steady state will be in dynamic equilibrium since a steady state may be achieved without a reversible reaction or a closed system. For example, if reactants are added to a reaction mixture at the same rate that the products are removed, then a steady state will be achieved even though the system will not be at equilibrium.

### Equilibrium in chemical systems

When reactants are initially placed in a system, their concentrations are high compared to the concentration of products. This means that the rate of the forward reaction is relatively high. Since there are initially no products, the reverse reaction is unable to occur.

As the products form from the forward reaction, their concentration increases. This means that the reverse reaction will start to occur, and its rate will increase as the concentration of the products increases. This will occur only in a closed system where the products remain in the chemical system and so are available for the reverse reaction.

Therefore, the:

- ▶ rate of the forward reaction will decrease as the concentration of the reactants decreases
- ▶ rate of the reverse reaction will increase as the concentration of the products increases.

This trend will continue until the rate of the forward reaction is the same as the rate of the reverse reaction. At this point, products are formed at the same rate that they are used up. Therefore, the concentrations of the reactants and products will remain constant. When this happens, the system is said to be in dynamic equilibrium.

When a system is at dynamic equilibrium, the concentrations of the reactants and products remain constant (Figure 2.9). This means that the macroscopic properties will also remain constant. For example, the colour will remain constant or the mass of a solid will stay the same. It is important to realise that although the concentrations must be constant for the system to be at equilibrium, they do not need to be equal and it is unlikely that they will be equal.

In summary, a chemical system will reach equilibrium if it:

- ▶ is a closed system
- ▶ involves a reversible reaction.

At equilibrium, the:

- ▶ rate of the forward reaction is the same as the rate of the reverse reaction
- ▶ concentrations of the reactants and products remain constant
- ▶ macroscopic properties are constant.



**FIGURE 2.9** A system at dynamic equilibrium will maintain constant macroscopic properties.



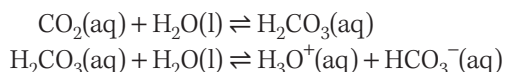
#### Dynamic equilibrium

View the animation to observe how the forward and reverse reactions of  $\text{N}_2(\text{g}) + \text{O}_2(\text{g}) \rightleftharpoons 2\text{NO}(\text{g})$  are occurring at the same rate to maintain equilibrium.

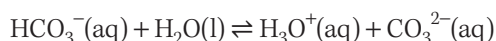
## Building shells – an example of equilibrium in nature

Many aquatic organisms rely on shells or skeletons for structure and protection (Figure 2.10).

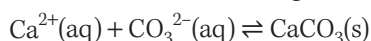
Carbon dioxide will react with water to produce hydrogen carbonate and hydronium ions ( $\text{H}_3\text{O}^+$ ):



The hydrogen carbonate ion is able to further react to form carbonate and hydronium ions:



If there are calcium ions available in the solution, then they will combine with the carbonate ion to form insoluble calcium carbonate. This provides the minerals that give shells and skeletons their strength:



Although calcium carbonate is regarded as insoluble, in reality a very small amount is able to dissolve. This reaction is reversible, so, for the solid to form, the system must be at equilibrium and therefore a **saturated** solution is needed. If the solution is not saturated, then the reverse reaction (as written above) is favoured and thus any solid formed simply dissolves to form ions again.

It may seem unlikely that a saturated solution is able to be achieved in an ocean. However, since calcium carbonate has such a low solubility, it does occur. Any excess ions will be able to form the solid calcium carbonate needed for the shells, coral and skeletons of aquatic organisms.



**FIGURE 2.10** All of these shells contain calcium carbonate.

## INVESTIGATION 2.2

### Modelling equilibrium

#### INTRODUCTION

Equilibrium will be modelled in this investigation using pipettes, measuring cylinders and water.

Two 100 mL measuring cylinders with the same height and diameter will be used. They will be labelled A and B. The 10 mL pipette will be used to transfer water from measuring cylinder A to measuring cylinder B. This will model the forward reaction. The 5 mL pipette will be used to transfer water from measuring cylinder B to measuring cylinder A. This will model the reverse reaction.

#### AIM

To model a reversible reaction and determine when dynamic equilibrium has been reached.

#### MATERIALS

- 2 × 100 mL measuring cylinders (same height and same diameter)
- 2 × 10 mL graduated pipettes
- 2 × 5 mL graduated pipettes
- 2 small labels
- Water



**WHAT ARE THE RISKS IN DOING THIS INVESTIGATION?**

Broken glassware will cut.

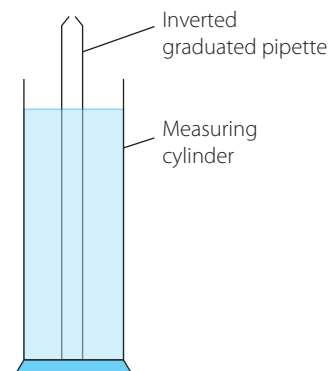
**HOW CAN YOU MANAGE THESE RISKS TO STAY SAFE?**

Ensure that the glassware is away from the edge of the bench. Ensure the graduated pipettes are placed so they do not roll off the bench.

What other risks are associated with your investigation? How can you manage these?

**METHOD**

- 1 Label two 100 mL measuring cylinders A and B.
- 2 Fill measuring cylinder A with 100 mL of water.
- 3 Record the volume of water in each of the measuring cylinders.
- 4 Turn the 10 mL graduated pipette upside down and place it into measuring cylinder A so the large opening is in the measuring cylinder and allow it to fill with water (Figure 2.11).
- 5 Use your thumb to tightly seal the exposed tip of the pipette and carefully transfer the contents of this pipette to measuring cylinder B.
- 6 Turn the 5 mL graduated pipette upside down and place it into measuring cylinder B so the large opening is in the measuring cylinder and allow it to fill with water.
- 7 Use your thumb to tightly seal the exposed tip of the pipette and carefully transfer the contents of this pipette to measuring cylinder A.
- 8 Record the volume of water in each of the measuring cylinders. This is the end of cycle 1.
- 9 Repeat steps 4–7 until 50 cycles have been completed. Record the volume of water in each of the measuring cylinders at the end of each cycle.



**FIGURE 2.11**  
Graduated pipette upside down in a measuring cylinder

**RESULTS**

Record volumes of water in each of the measuring cylinders in a table.

**ANALYSIS OF RESULTS**

- 1 Use a spreadsheet program to graph the results for the 50 cycles for each of the measuring cylinders, A and B, on the same set of axes.
- 2 The slope of each of the graphs indicates the rate of the reaction for that reaction (forward or reverse). Compare the rates of reaction for each of the graphs during the first 5 cycles with the last 5 cycles.

**CONCLUSION**

- 1 Justify whether the reaction reached dynamic equilibrium.
- 2 Evaluate this model's effectiveness for modelling dynamic equilibrium.

**EXTENSION**

- 1 Repeat the investigation but start with 30 mL in measuring cylinder A and 70 mL in measuring cylinder B. Did the system still reach equilibrium? Was the equilibrium position the same?
- 2 How could you model changing the rate for this equilibrium system? Plan and perform this investigation. Did the system still reach equilibrium? Was the equilibrium position the same?

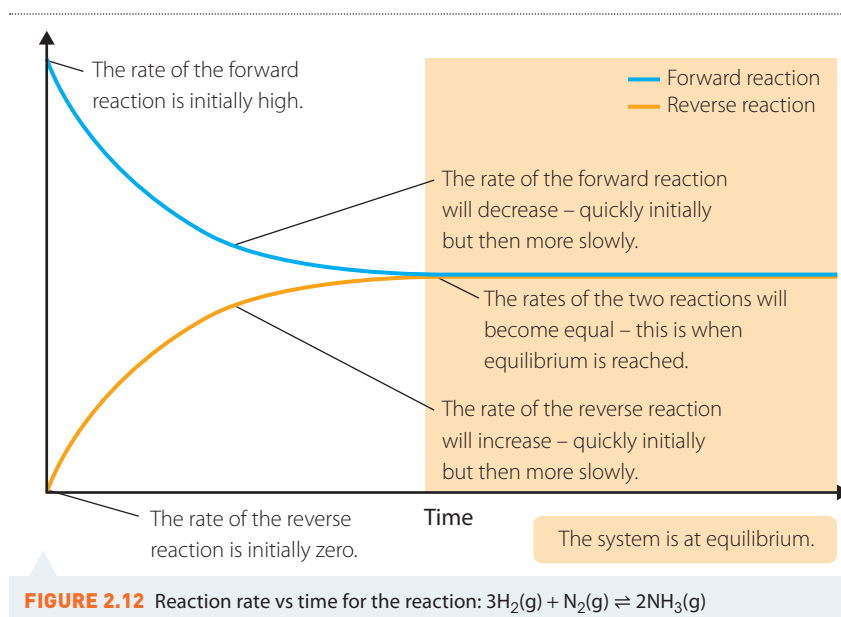
## Graphing and equilibrium

Graphing is used in many situations to visually represent data. When you are studying chemical systems involving equilibrium, you can use graphs to consider either the rates of the reactions or the concentrations of the substances over time.

### Graphing reaction rate and time

Figure 2.12 shows the key features for a graph of reaction rate versus time. Starting with reactants only, you will observe that the rate of the:

- ▶ forward reaction is initially high
- ▶ reverse reaction is initially zero
- ▶ forward reaction will decrease – quickly initially but then more slowly
- ▶ reverse reaction will increase – quickly initially but then more slowly
- ▶ two reactions will become equal – this is when equilibrium is reached.



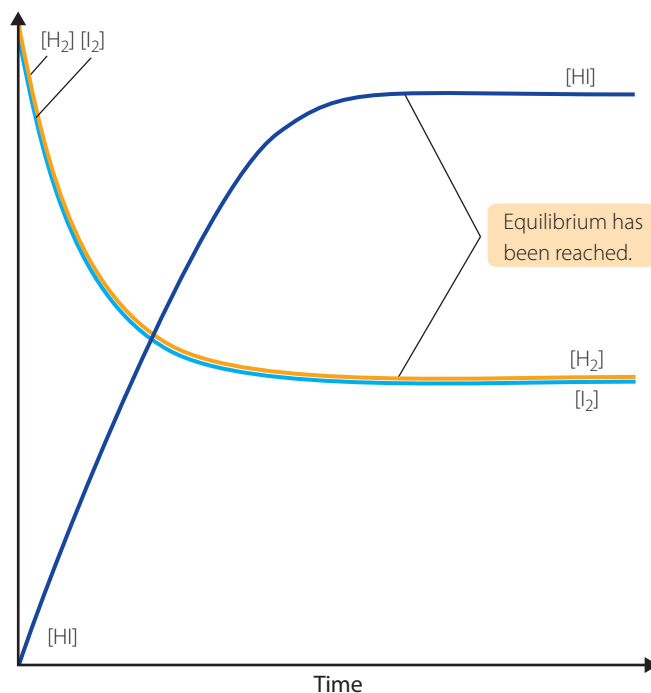
### Graphing concentration and time

Similarly, you can use a graph to represent the changes in concentration during a reaction as it reaches equilibrium. Figure 2.13 (page 38) uses the reaction  $\text{H}_2(\text{g}) + \text{I}_2(\text{g}) \rightleftharpoons 2\text{HI}(\text{g})$  to illustrate this. Typically, the reaction will start with only reactants; therefore, the concentration(s) of:

- ▶ reactants is initially large
- ▶ products is initially zero
- ▶ reactants decrease – initially quickly (steep graph) and then more slowly
- ▶ products increase – initially quickly (steep graph) and then more slowly
- ▶ all will plateau when the system reaches equilibrium.

Table 2.1 (page 38) gives a summary of drawing rate and concentration graphs.

**FIGURE 2.13**  
Concentration vs time  
for the reaction:  
 $\text{H}_2(\text{g}) + \text{I}_2(\text{g}) \rightleftharpoons 2\text{HI}(\text{g})$



**TABLE 2.1** Graphing concentration and reaction rate versus time

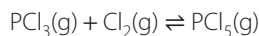
GRAPH	NUMBER OF LINES	POSITION OF LINE AT EQUILIBRIUM
Concentration vs time	Any number depending on the number of reactants and products. Each is represented on the graph by a separate line.	All lines become horizontal as concentrations are constant. They do not need to be of equal value.
Reaction rates vs time	Two lines – forward reaction and reverse reaction	The two lines meet and plateau as the two rates are equal.

- Dynamic equilibrium:
  - is the state that is reached when the amount of reactants and products remains constant
  - is reached when the rate of the forward reaction equals the rate of the reverse reaction.

**CHECK YOUR UNDERSTANDING**

2.3

- 1 State the requirements for dynamic equilibrium.
- 2 Explain the difference between a steady state and dynamic equilibrium.
- 3 Describe what you would observe in a system at equilibrium.
- 4 Equal moles of the gases  $\text{PCl}_3$  and  $\text{Cl}_2$  are placed in a closed container and react until they reach equilibrium according to the equation:



Sketch a graph showing the relative concentrations of all species in the system.



Critical and  
creative thinking



- 5 Figure 2.14 shows the concentrations of various chemical species over time.
- Write an equation for this chemical system.
  - Describe the initial concentrations for this reaction.
  - At what time did the system reach equilibrium? Justify your answer.

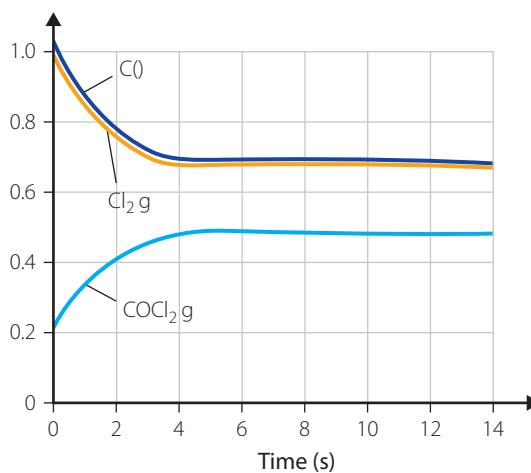


FIGURE 2.14 Concentrations of various chemical species over time

## 2.4 Changes to equilibrium

The conditions of the system determine the point at which equilibrium is established. By understanding what happens during a reaction, you can explain the changes in equilibrium when these conditions are altered. This also allows us to choose conditions that best suit the purpose of the reaction.

If the conditions of temperature, concentration or **partial pressure** of chemicals or volume of a system at equilibrium are changed, the system will no longer be at equilibrium. Equilibrium will be re-established as the forward or reverse reaction proceeds at a faster rate.

If the forward reaction is favoured, then equilibrium has shifted to the right. This is because more products will be produced (and in the equation, the products are written on the right-hand side). Conversely, if the reverse reaction is favoured, then equilibrium shifts to the left due to the production of more reactants. **Note:** This does not mean that equilibrium literally sits on the left or right. These are simply expressions comparing the relative equilibrium concentrations before, and then after, a change.

### Le Chatelier's principle

Henri Louis Le Chatelier summarised the trends involved in a change in the conditions of a system at equilibrium in **Le Chatelier's principle**. This principle can be used to predict the changes that will occur following a change in the conditions (that is, concentration of chemicals, pressure, volume or temperature of a system). Le Chatelier's principle states that:

'If a system at equilibrium is subject to a change in conditions, then the system will behave in such a way so as to partially counteract the imposed change.'

To use Le Chatelier's principle to predict the outcome of a change in conditions, you need to consider the following points.

- What change is imposed?
- What is the opposite of the change? (This is what the system will do.)
- Which reaction direction is favoured – the forward or reverse?
- Does equilibrium shift to the left or right?
- What happens to the concentrations of each aqueous substance or gas?



## Changes to concentration and partial pressure



According to Le Chatelier's principle, when the concentration of a substance involved in a reaction is altered, the system will react to counteract the change and return the concentration towards its original level.

This means that if the concentration of a reactant is increased, then the system will adjust to decrease it by favouring the forward reaction, which uses up the reactant. This shifts equilibrium to the right, increasing the concentration of the products and decreasing the concentration of the reactants. However, the concentration of the substance added will not return to its original concentration since the system can only partially counteract the change.

Alternatively, if the concentration of a product is decreased, then the system will favour the reaction that forms products to increase the concentration again. Therefore, the forward reaction will be favoured and equilibrium will shift to the right.

The partial pressure of a gas and its concentration are related because they are both due to the number of particles in a given volume. Therefore, a change in partial pressure will cause a proportional change in concentration. This means that in a gaseous system, the partial pressures of the gases can be used to indicate the concentration.

Consider the reaction between hydrogen and iodine to form hydrogen iodide:

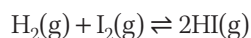
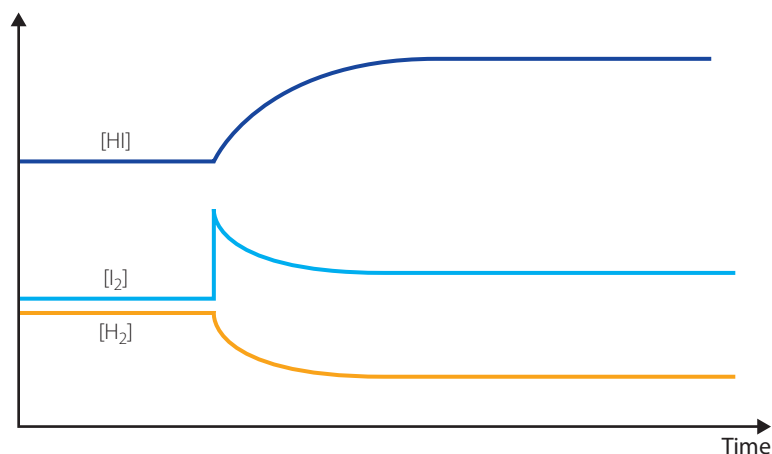


Figure 2.15 shows a visual representation of a system at equilibrium being disrupted by a change in concentration of one of the reactants, then the system re-establishing equilibrium. The changes can be explained by considering collision theory.

When more iodine is added to the system, then the concentration of the iodine is increased. This is indicated by a sudden change in the iodine graph in Figure 2.15. As the iodine is a reactant for the forward reaction, the rate of the forward reaction will increase due to more successful collisions. As the forward reaction proceeds the concentration of hydrogen gas and iodine gas will decrease, while the concentration of the gaseous hydrogen iodide product will increase.

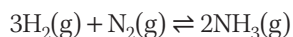
The increasing concentration of hydrogen iodide means the chances of successful collisions between hydrogen iodide molecules also increases, and therefore, the rate of the reverse reaction will begin to increase.

This pattern will continue until the rates of the forward and reverse reactions are once again equal. At this time, the concentrations of each chemical will remain constant. The new equilibrium concentration of iodine will be lower than the concentration following the addition of the extra iodine. However, it will not return to its original equilibrium concentration.



**FIGURE 2.15** Concentrations of reactants and product following a change in concentration for the reaction:  $\text{H}_2(\text{g}) + \text{I}_2(\text{g}) \rightleftharpoons 2\text{HI}(\text{g})$

Consider the equilibrium established during the production of ammonia:



If hydrogen gas is added to the container without a change in volume, then the concentration of hydrogen gas will increase. According to Le Chatelier's principle, the system will react to reduce this increased concentration, thus favouring the forward reaction, which uses up hydrogen gas. Therefore, the reaction will shift to the right and the concentrations of hydrogen gas and nitrogen gas will decrease, while the concentration of ammonia will increase. As above, since additional hydrogen gas has been added, the new equilibrium concentration will be above the value before addition.

The same logic can be applied to a decrease in the concentration as shown in Table 2.2. A decrease in concentration of a reactant will lead to a decrease in the rate of the forward reaction since there is less chance of successful collisions involving that reactant. The reverse reaction will initially continue at the equilibrium rate, resulting in more reactants and less product. Over time, the concentration of the reactants for that reaction will increase, while the concentration of the products for that reaction will decrease. However, the concentration of the reactant that was removed will not return to the original concentration.

**TABLE 2.2** The effect of a change in concentration or partial pressure on equilibrium

IMPOSED CHANGE		REACTION FAVOURED (FORWARD OR REVERSE)	SHIFT IN EQUILIBRIUM (LEFT OR RIGHT)	RESULTANT CHANGE IN CONCENTRATION OR PARTIAL PRESSURE OF REACTANTS	RESULTANT CHANGE IN CONCENTRATION OR PARTIAL PRESSURE OF PRODUCTS
PRODUCT OR REACTANT ALTERED	INCREASE OR DECREASE IN CONCENTRATION OR PARTIAL PRESSURE				
Reactant	Increase	Forward	Right	Decrease	Increase
Reactant	Decrease	Reverse	Left	Increase	Decrease
Product	Increase	Reverse	Left	Increase	Decrease
Product	Decrease	Forward	Right	Decrease	Increase

## INVESTIGATION 2.3

### Effect of changes to concentration on equilibrium

#### INTRODUCTION

The effect of changes to concentration on equilibrium can be represented by the following equation:



The complex ion ( $\text{FeSCN}^{2+}$ ) is a deep red colour. Changes in colour indicate the adjustment to the equilibrium system.

#### AIM

To observe the effect of a change in concentration on a system at equilibrium.

#### MATERIALS

- 2 mL of 0.1 mol L<sup>-1</sup> iron(III) chloride solution
- 2 mL of 0.1 mol L<sup>-1</sup> ammonium thiocyanate solution
- 1 mL of 0.1 mol L<sup>-1</sup> calcium fluoride solution
- 20 mL distilled water



Critical and creative thinking



Information and communication technology capability



- » 2 × 10 mL measuring cylinders
- » 25 mL measuring cylinder
- » 4 test tubes
- » Test-tube rack
- » 4 small labels
- » Disposable 1 mL droppers
- » Waste bottle
- » Digital camera
- » Safety glasses



WHAT ARE THE RISKS IN DOING THIS INVESTIGATION?	HOW CAN YOU MANAGE THESE RISKS TO STAY SAFE?
Chemicals may splash onto your skin or into your eyes.	Wear safety glasses and wash your hands at the end of the experiment.
FeSCN <sup>2+</sup> is harmful to aquatic life.	Do not pour down the sink. Pour into waste bottle provided.

What other risks are associated with your investigation? How can you manage these?

#### METHOD

- 1 Pour 1 mL of iron(III) chloride solution into a 10 mL measuring cylinder.
- 2 Pour 1 mL of ammonium thiocyanate into another 10 mL measuring cylinder.
- 3 Pour both solutions into the 25 mL measuring cylinder.
- 4 Add 18 mL of distilled water to the 25 mL measuring cylinder so that the total volume is 20 mL.
- 5 Label four test tubes A, B, C and D.
- 6 Pour equal volumes of the solution in the 25 mL measuring cylinder into each of the test tubes.
- 7 Retain test tube A as the reference solution.
- 8 Add 1 mL of iron(III) chloride to test tube B.
- 9 Take a photo to record observations for test tube B relative to test tube A.
- 10 Add 1 mL of ammonium thiocyanate to test tube C.
- 11 Take a photo to record observations for test tube C relative to test tube A.
- 12 Add 1 mL of calcium fluoride to test tube D. (**Note:** This reacts with the iron(III) ion so there is less iron(III) available to react with the thiocyanate ion.)
- 13 Take a photo to record observations for test tube D relative to test tube A.

#### RESULTS

Present your observations in a simple table.

#### DISCUSSION

Compare the colours observed in steps 8–13 to the reference test tube (test tube A). Suggest a reason for any differences that occurred.

#### CONCLUSION

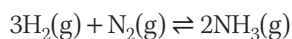
Use Le Chatelier's principle to explain what happened in test tubes B, C and D.

## Changes to volume and pressure

When the volume or pressure of a gaseous system is changed, the concentrations of all gaseous substances in that system are altered. This means that the concentration of both reactants and products may change. Whichever one changes the most will have the greatest influence on the change of equilibrium.

When the volume of a closed vessel containing gaseous substances is increased, the molecules have more space to move around. Hence, initially, the concentration of all substances decreases (Figure 2.16), since there are the same number of molecules of each substance present in a larger volume. This also results in a decrease in the pressure of the system since pressure and volume are inversely proportional. However, according to Le Chatelier's principle, the system will adjust to overcome this change and hence, in this case, it will favour the reaction that increases pressure by increasing the number of gaseous molecules.

Let us illustrate this by considering the reaction between nitrogen gas and hydrogen gas to produce ammonia:



You can see that there is a 4:2 ratio of gas molecules between the reactants and products – 3 molecules of  $\text{H}_2$  and 1 molecule of  $\text{N}_2$  are used for every 2 molecules of  $\text{NH}_3$  produced.

If the volume of the system was doubled, then the pressure, and therefore concentration, of all the gases would halve. Figure 2.17 shows a sudden decrease in the concentration of each of the gases ( $\text{NH}_3$ ,  $\text{H}_2$ ,  $\text{N}_2$ ). The concentration of each of the gases after the sudden decrease is half of their initial values. The decreased concentration means there is less chance that the molecules will successfully collide so the rate of both the forward and reverse reactions would decrease.

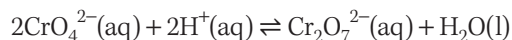
As the reactions proceed:

- initially, the reverse reaction will be favoured to increase the concentrations of hydrogen and nitrogen since this will increase the total concentration of gases in the system and therefore increase the pressure of the system
- consequently, the concentration of ammonia will decrease and the rate of the reverse reaction will decrease since there is less chance that these molecules will successfully collide.

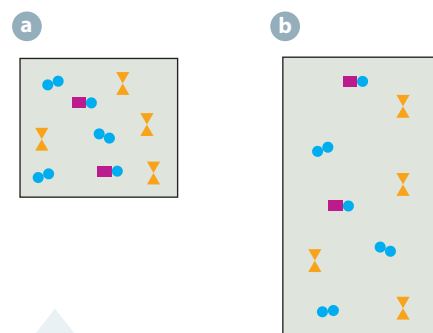
This will continue until the two rates of reaction are once again equal and equilibrium is re-established. The opposite will happen if the volume of a gaseous system is decreased.

If the volume of a solution is changed by adding or removing water, then the same principle will apply since the concentration of all aqueous substances will change. For example, if water is added to the solution, then the concentration of all aqueous components will decrease. The rate of the reaction that uses the greater proportion of aqueous molecules will initially decrease the most. The rate of this reaction will then gradually increase, while the rate of the opposite reaction will decrease until the two are once again equal and equilibrium is re-established.

Consider the equilibrium between chromate and dichromate:

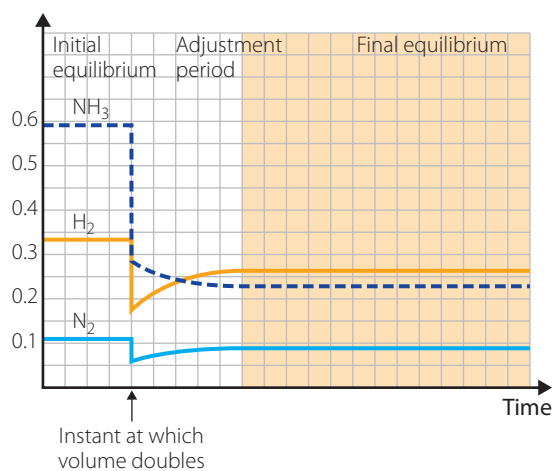


If water is added to the solution, then the concentration of all the aqueous substances will decrease. In aqueous solution, the concentration of water is assumed to be constant. Therefore, on the graph in Figure 2.18 (page 44), there will be sudden drops in the concentration of chromate, hydrogen ions and dichromate. Since four aqueous molecules are used to produce only one dichromate molecule, the reverse reaction will be favoured. This will use up dichromate and produce chromate and hydrogen ions. Therefore, the concentration of chromate and hydrogen ions will increase, while the concentration of dichromate will decrease until the concentrations once again plateau and remain constant.



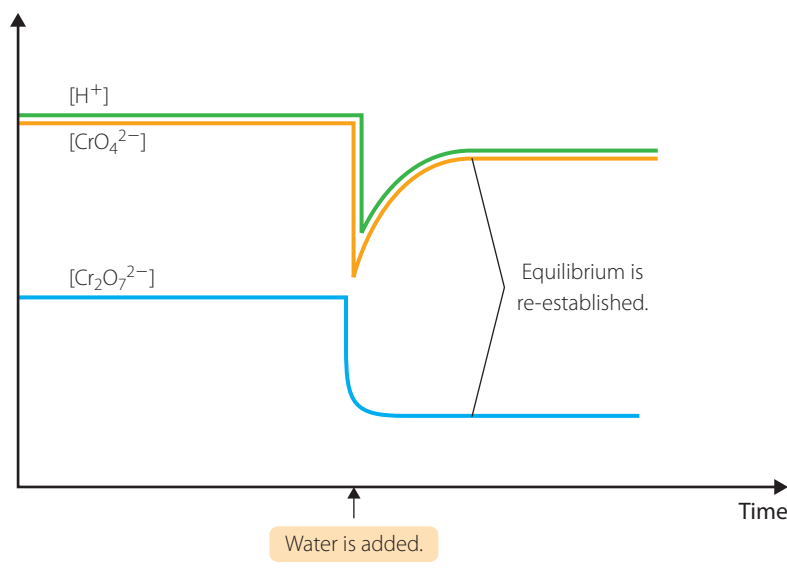
**FIGURE 2.16** **a** Gaseous molecules of reactants and products in a particular volume **b** gaseous molecules of reactants and products when volume of system has been doubled

**Changes to the volume of a gaseous system**  
Visit the weblink to see a graph that shows the relative number of moles of substances involved in the reaction:  
 $\text{C}(\text{s}) + \text{H}_2\text{O}(\text{g}) \rightarrow \text{CO}(\text{g}) + \text{H}_2(\text{g})$ .



**FIGURE 2.17** Changing the volume of a gaseous system

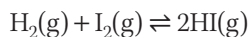
**FIGURE 2.18**  
Concentrations of reactant and product following a change in volume



## No change

Another situation to consider is where there are an equal number of gas (or aqueous) molecules in the reactants and products of the equation. This means that if the volume is changed, then the concentration of reactants and products change equally and both have an equal chance of having successful collisions. Therefore, the rates of both the forward and reverse reactions also change equally and remain equal. Hence, equilibrium has not been altered.

For example, in the reaction:



there are two molecules of gas in the reactants ( $1 \times \text{H}_2$  and  $1 \times \text{I}_2$ ) and two molecules of gas in the products ( $2 \times \text{HI}$ ). Therefore, there are an equal number of moles of gas on both sides. A change in the volume of the container would not affect equilibrium.

## INVESTIGATION 2.4



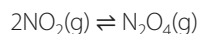
Critical and  
creative  
thinking

### Teacher demonstration: Changing the volume of a gaseous system at equilibrium

#### INTRODUCTION

**Note:** This investigation can be done either as a primary source investigation (teacher demonstration only) or, using the weblink, as a secondary source investigation.

An equilibrium exists between the gases nitrogen dioxide and dinitrogen tetraoxide, as per the reaction:



Nitrogen dioxide is a brown gas, while nitrogen tetraoxide is colourless. This means the colour can indicate the proportion of gases in the mixture. A darker brown indicates a greater concentration of nitrogen dioxide and therefore an equilibrium that lies further to the left. Conversely, a lighter brown colour indicates a lower concentration of nitrogen dioxide and therefore an equilibrium that lies further to the right.



$2\text{NO}_2 \rightleftharpoons \text{N}_2\text{O}_4$   
equilibrium

## » AIM

To observe the effect of changing the volume of a gaseous system at equilibrium.

## MATERIALS

- Large, transparent syringe containing  $\text{NO}_2/\text{N}_2\text{O}_4$

### WHAT ARE THE RISKS IN DOING THIS INVESTIGATION?

$\text{NO}_2/\text{N}_2\text{O}_4$  is hazardous if inhaled or comes into contact with skin, eyes or mucous membranes.

### HOW CAN YOU MANAGE THESE RISKS TO STAY SAFE?

Ensure the syringe is sealed. Conduct experiment in a fume cupboard.



What other risks are associated with your investigation? How can you manage these?

## METHOD

- Your teacher will demonstrate this experiment.
- Observe the colour of the gas mixture in the syringe.
- Quickly push in the plunger of the syringe to reduce the volume. Observe the immediate change in the colour of the gas mixture and then the changes that occur over the next few seconds as equilibrium is re-established.

## RESULTS

Record your observations in a simple table.

## ANALYSIS OF RESULTS

- What happened to the intensity of the colour when the volume was initially reduced? Why did this occur?
- What happened to the intensity of the colour as equilibrium was re-established? Why did this occur?

## DISCUSSION

- Use your knowledge of collision theory to account for the changes that were observed.
- Predict the changes that would be observed if the volume of the system was increased. Your teacher may demonstrate this for you so that you can see whether your prediction is correct.
- What factors would affect the change observed in a gaseous system when the volume is altered?

## CONCLUSION

What conclusion can you make about the changes that are observed when the volume is changed in a gaseous system?

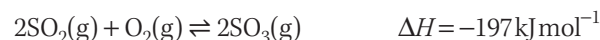


Practical activity  
and thought exercise

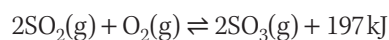
## Changes to temperature

When the temperature of a system at equilibrium is altered, there are no sudden initial changes in concentration. This is reflected in a graph of concentration versus time by no sudden changes in concentration. However, one reaction will be favoured as equilibrium is being re-established. Therefore, the concentrations will gradually change as the system counteracts the change.

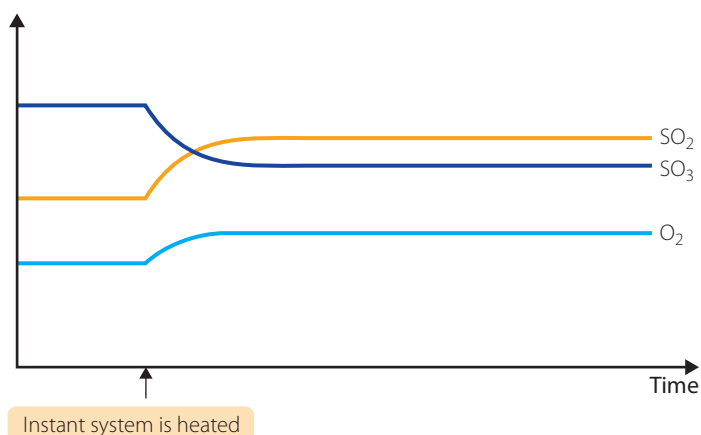
Consider the reaction between sulfur dioxide and oxygen to produce sulfur trioxide (which is an exothermic reaction):



This reaction could be rewritten with the energy term as part of the equation. Since it is an exothermic reaction, heat energy is being produced, so the energy term can be included on the right side of the equation, as follows:







**FIGURE 2.19** Concentrations with a change in temperature for the reaction  $2\text{SO}_2(\text{g}) + \text{O}_2(\text{g}) \rightleftharpoons 2\text{SO}_3(\text{g})$

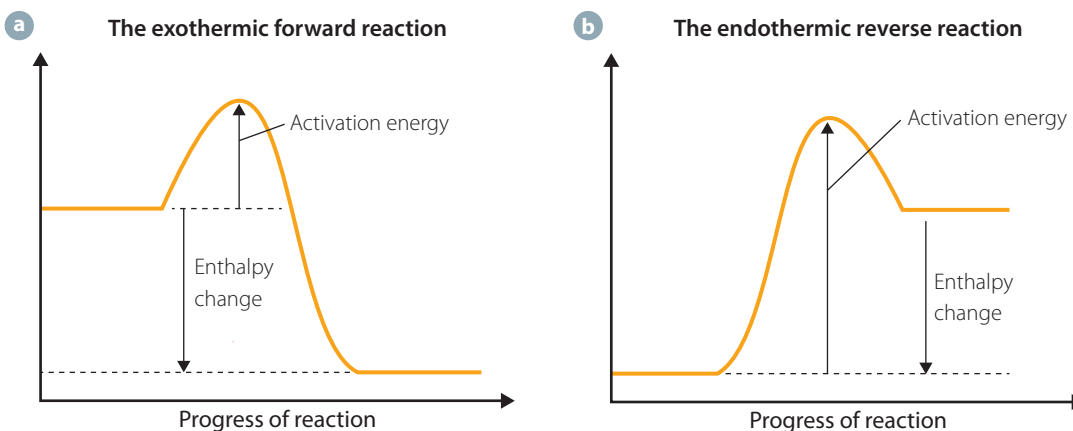
This means that the forward reaction is exothermic (releases energy), while the reverse reaction is endothermic (absorbs energy). If the temperature (hence, energy) of the system is increased, then according to Le Chatelier's principle, the system will favour the reaction that absorbs the energy, and hence, the endothermic reaction will be favoured (that is, the reverse reaction will be favoured). This will result in an increase in the concentrations of  $\text{SO}_2(\text{g})$  and  $\text{O}_2(\text{g})$  and a decrease in the concentration of  $\text{SO}_3(\text{g})$ . This is illustrated in Figure 2.19.

Alternatively, if the temperature is decreased, then the exothermic reaction will be favoured in order to produce heat energy to increase the temperature.

The effect of temperature changes on a chemical system can be explained by considering the difference in enthalpy changes for the forward and the reverse reactions.

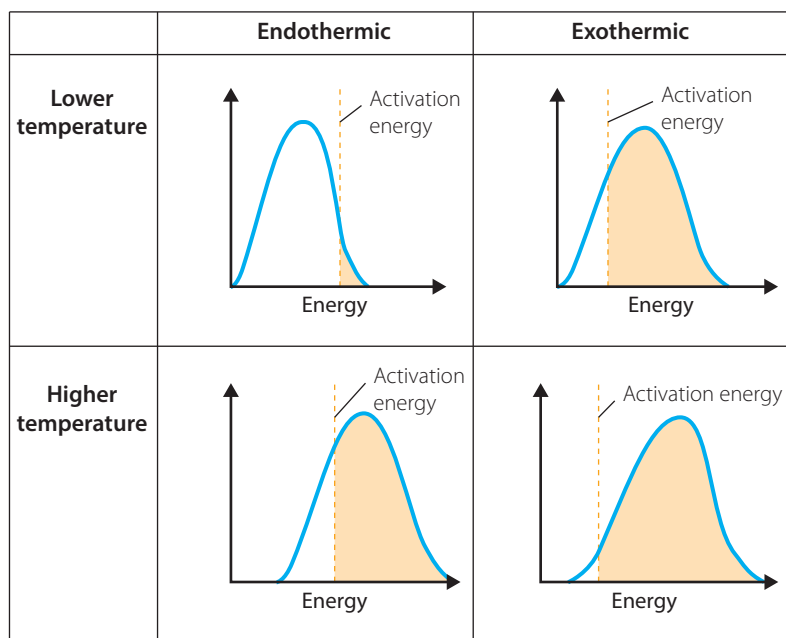
Remember that in an **exothermic reaction**, the products have less enthalpy than the reactants, meaning that energy will be released to the surroundings. Alternatively, in an **endothermic reaction**, the reactants have less enthalpy than the products and therefore energy will be absorbed from the surroundings.

In a reversible reaction, the reaction in one direction will be endothermic, while the reaction in the opposite direction will be exothermic. The higher enthalpy of the reactants in the exothermic reaction means that the exothermic reaction will have a lower activation energy than the endothermic reaction for the same reversible reaction. This is illustrated in Figure 2.20.



**FIGURE 2.20** Comparing the activation energy for the forward and reverse reactions of: reactants  $\rightleftharpoons$  products + energy. Note how the activation energy for the exothermic reaction is less than the activation energy for the endothermic reaction.

When the temperature of a system is increased, the rate of both the forward and reverse reactions will increase since all molecules have more kinetic energy, and hence, have a greater chance of successfully colliding and reacting. However, the rate of the endothermic reaction will increase, and this is due to the higher activation energy. The increase in temperature will affect the percentage of particles able to react in the endothermic reaction more than in the exothermic reaction. This is illustrated in Figure 2.21.



■ Molecules that have sufficient energy to successfully collide and react.

**FIGURE 2.21**

Effect of an increase in temperature on the proportion of molecules with sufficient energy to react for both endothermic and exothermic reactions

As more of the products of the endothermic reaction are produced, the opposite, exothermic reaction rate will increase because there are more molecules of products present to collide and react. At the same time as these reactants are used up, the rate of the endothermic reaction will decrease. This trend will continue until the two rates are once again equal and the system is at equilibrium. It should be noted that while the rate describes how equilibrium is achieved, it is not the rate that drives the equilibrium change.

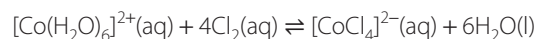
In summary, if the change in temperature favours the forward reaction, then there will be an increase in the concentration of products and a decrease in the concentration of the reactants. Alternatively, if the reverse reaction is favoured, then there will be an increase in the concentration of the reactants and a decrease in the concentration of products.

## INVESTIGATION 2.5

### Effect of temperature on a system at equilibrium

#### INTRODUCTION

An equilibrium will exist between  $[\text{Co}(\text{H}_2\text{O})_6]^{2+}$  and  $[\text{CoCl}_4]^{2-}$  when they are in a solution. The equation representing this is:



The  $[\text{Co}(\text{H}_2\text{O})_6]^{2+}$  ion is a pink colour, while the  $[\text{CoCl}_4]^{2-}$  ion is a deep blue colour. Therefore, the relative concentrations of the ions and the position of equilibrium will be indicated by the colour of the solution. A blue solution indicates a high concentration of  $[\text{CoCl}_4]^{2-}$  compared to  $[\text{Co}(\text{H}_2\text{O})_6]^{2+}$ . Alternatively, a pink solution indicates a high concentration of  $[\text{Co}(\text{H}_2\text{O})_6]^{2+}$  compared to  $[\text{CoCl}_4]^{2-}$ .



Critical and creative thinking



## » AIM

To observe the effect of changing the temperature of a system at equilibrium.

## MATERIALS

- 3 g cobalt(II) chloride-6-water [ $\text{CoCl}_2 \cdot 6\text{H}_2\text{O}$ ]
- 5 mL of concentrated hydrochloric acid
- Distilled water
- Measuring cylinder (5 mL)
- 3 large test tubes
- Test-tube rack
- Test-tube tongs
- Bunsen burner
- Heat mat
- Matches
- Safety glasses



WHAT ARE THE RISKS IN DOING THIS INVESTIGATION?	HOW CAN YOU MANAGE THESE RISKS TO STAY SAFE?
Chemicals may splash onto your skin or into your eyes.	Wear safety glasses and wash your hands at the end of the experiment.
Concentrated HCl is very corrosive to skin and clothes.	Concentrated HCl is for teacher use only. If any acid comes in contact with skin, wash it immediately with plenty of water.
Cobalt(II) chloride-6-water may be an irritant to eyes, skin and respiratory systems. It may cause cancer.	Use in a well-ventilated area. Wear safety glasses. If any comes in contact with skin, wash it immediately with plenty of water.

What other risks are associated with your investigation? How can you manage these?

## METHOD

- Dissolve a pea-sized amount of  $\text{CoCl}_2 \cdot 6\text{H}_2\text{O}$  in 1–2 mL of distilled water in a test tube. Observe and record the colour of the resultant solution. This colour is due to the  $[\text{Co}(\text{H}_2\text{O})_6]^{2+}$  ion. Keep this test tube as a reference.
- Dissolve a pea-sized amount of  $\text{CoCl}_2 \cdot 6\text{H}_2\text{O}$  in 1–2 mL of concentrated hydrochloric acid in a clean test tube. Observe and record the colour of the resultant solution. This colour is due to the  $[\text{CoCl}_4]^{2-}$  ion. Keep this test tube as a reference.
- Dissolve a pea-sized amount of  $\text{CoCl}_2 \cdot 6\text{H}_2\text{O}$  in 1–2 mL of distilled water in the third test tube. Gently heat the solution over the Bunsen burner until the solution is almost boiling. Observe and record the colour change.
- Allow the third test tube to cool down, observing and recording the colour change.

## RESULTS

Record your results in a simple table.

## ANALYSIS OF RESULTS

- What colour change was observed when the test tube was heated? What does this colour indicate regarding the relative proportion of the two ions?
- What colour change was observed when the test tube cooled down? What does this colour indicate regarding the relative proportion of the two ions?

## DISCUSSION

- Which reaction was favoured when the test tube was heated?
- Is the forward reaction exothermic or endothermic? Explain your answer.

## CONCLUSION

What conclusion can you make regarding the effect of temperature on the equilibrium between  $[\text{Co}(\text{H}_2\text{O})_6]^{2+}$  and  $[\text{CoCl}_4]^{2-}$ ?

## Addition of a catalyst

The addition of a catalyst does not affect equilibrium. However, it does affect how quickly equilibrium is attained. A catalyst will decrease the activation energy of both the forward and reverse reactions equally. The rates of both reactions will increase; however, they change by the same proportion. This is why equilibrium is not disturbed.



Dominoes



Check your understanding

## Summary of identifiable changes on a graph

Table 2.3 summarises how changes to a system can be identified on a graph.

**TABLE 2.3** How changes to a system can be identified on a graph

CHANGE TO SYSTEM	KEY POINT ON GRAPH
Increase in concentration or partial pressure of one substance	Sudden increase in one substance
Decrease in concentration or partial pressure of one substance	Sudden decrease in one substance
Increase in volume/decrease in pressure of system	Sudden decrease in all gaseous species
Decrease in volume/increase in pressure of system	Sudden increase in all gaseous species
Increase in temperature	No sudden changes
Decrease in temperature	No sudden changes
Addition of catalyst	Reaches same equilibrium position in a shorter time

- Le Chatelier's principle states that:
  - If a system at equilibrium is subject to a change in conditions, then the system will behave in such a way so as to partially counteract the imposed change.

- State Le Chatelier's principle.
- Describe the effect on the energy of particles if the temperature is decreased.
- $\text{CH}_4(\text{g}) + \text{H}_2\text{O}(\text{g}) \rightleftharpoons \text{CO}(\text{g}) + 3\text{H}_2(\text{g})$  (endothermic reaction)  
Justify whether the forward or reverse reaction is favoured when:
  - adding  $\text{H}_2$
  - decreasing the temperature
  - increasing the pressure of the system.
- Silver ions can be removed from solution by adding carbonate ions, such as in the reaction:
$$2\text{Ag}^+(\text{aq}) + \text{CO}_3^{2-}(\text{aq}) \rightleftharpoons \text{Ag}_2\text{CO}_3(\text{s})$$
Describe two processes that would increase the amount of silver removed.
- Soluble sodium hypochlorite pellets are used in swimming pools to help kill bacteria and algae:
$$\text{ClO}^-(\text{aq}) + \text{H}^+(\text{aq}) \rightleftharpoons \text{HClO}(\text{aq}) + \text{heat}$$
Use Le Chatelier's principle to predict the changes that would occur for each of the following (assume the pool is covered and is therefore a closed system).
  - Adding more sodium hypochlorite pellets
  - The pool warming up during a hot day
- Explain, in terms of collision theory, the effect of increasing the temperature for the reaction:
$$3\text{H}_2(\text{g}) + \text{N}_2(\text{g}) \rightleftharpoons 2\text{NH}_3(\text{g}) \quad \Delta H = -92 \text{ kJ/mol}$$

CHECK YOUR UNDERSTANDING

2.4

# 2 CHAPTER SUMMARY

## IMPORTANT NEW TERMS

After studying this chapter you should know the meaning of the following terms:

activated complex (p. 32)

activation energy (p. 32)

chemical change (p. 28)

chemical system (p. 28)

closed system (p. 28)

collision theory (p. 32)

dynamic equilibrium (p. 29)

endothermic reaction (p. 46)

enthalpy (p. 25)

entropy (p. 25)

equilibrium (p. 25)

exothermic reaction (p. 46)

forward reaction (p. 29)

Le Chatelier's principle (p. 39)

open system (p. 28)

partial pressure (p. 39)

physical change (p. 28)

reverse reaction (p. 29)

reversible reaction (p. 28)

saturated (p. 35)

spontaneous (p. 25)

static equilibrium (p. 29)

steady state (p. 34)

surroundings (p. 28)

## AFTER STUDYING THIS CHAPTER YOU SHOULD KNOW:

- the definitions for all terms in the important new terms list
- the effect of entropy and enthalpy on determining whether a reaction occurs spontaneously
- the difference between an open system and a closed system
- the difference between static equilibrium, dynamic equilibrium and steady state
- the conditions for dynamic equilibrium
- the macroscopic properties of a system at equilibrium
- Le Chatelier's principle
- what the effects of changes to the concentration of chemical species are on the equilibrium position
- what the effects of changes to the volume, pressure and temperature of the system are to the equilibrium position
- the effect of temperature on endothermic and exothermic reactions
- the key features of graphs representing equilibrium systems
- the effect of a catalyst on the equilibrium position.

## YOU SHOULD BE ABLE TO:

- relate the  $\Delta G$  to whether the reaction is in equilibrium or not
- use collision theory to explain changes in the rate of a chemical reaction
- use Le Chatelier's principle to predict the effect of a change on an equilibrium system
- interpret changes to equilibrium systems that are represented as equations
- interpret changes to equilibrium systems that are represented graphically
- represent changes to equilibrium systems graphically
- relate Le Chatelier's principle and collision theory.

- 1 Which of the following represent equilibrium systems?
- A** A closed vessel containing  $\text{H}_2$ ,  $\text{I}_2$  and  $\text{HI}$  in which the concentrations of the species are constant and the rate at which  $\text{H}_2$  and  $\text{I}_2$  are being converted to  $\text{HI}$  is the same as the rate at which  $\text{HI}$  is being converted to  $\text{H}_2$  and  $\text{I}_2$
- B** A continuously burning Bunsen burner
- C** An open beaker of liquid that has been standing for some time
- D** A closed vessel of liquid that has been standing for some time
- E** A closed vessel containing some oxygen and helium gas

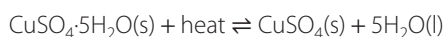
- 2 Which of the following equilibria is not affected by a change in pressure?

- A**  $2\text{H}_2\text{O}_2(\text{l}) + 2\text{H}_2\text{O}(\text{l}) \rightleftharpoons \text{O}_2(\text{g})$
- B**  $\text{N}_2(\text{g}) + \text{O}_2(\text{g}) \rightleftharpoons 2\text{NO}_2(\text{g})$
- C**  $2\text{Cl}(\text{g}) \rightleftharpoons \text{Cl}_2(\text{g})$
- D**  $2\text{SO}_3(\text{g}) \rightleftharpoons 2\text{SO}_2(\text{g}) + \text{O}_2(\text{g})$

- 3 A reversible reaction is at equilibrium and then a catalyst is added. Which of the following statements about the change to reaction rate is correct?

- A** Only the forward reaction rate increases.
- B** Only the reverse reaction rate increases.
- C** Both forward and reverse reaction rates increase equally.
- D** The forward reaction rate increases more than the reverse reaction rate.

- 4 Consider the following reaction in a closed container:



Which of the following would favour the formation of products?

- A** An increase in pressure
- B** Adding a catalyst
- C** Adding more water
- D** An increase in temperature

- 5 Use the concept of activation energy to explain why some reactions are not reversible.

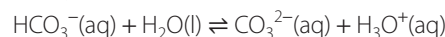
- 6 For each of the equations shown here, state what will happen to the equilibrium position in terms of product when heat is added to them in closed systems.

- a**  $\text{PCl}_5(\text{g}) + \text{heat} \rightleftharpoons \text{PCl}_3(\text{g}) + \text{Cl}_2(\text{g})$
- b**  $2\text{HgO}(\text{s}) + \text{heat} \rightleftharpoons 2\text{Hg}(\text{l}) + \text{O}_2(\text{g})$
- c**  $\text{FeO}(\text{s}) + \text{CO}(\text{g}) \rightleftharpoons \text{Fe}(\text{s}) + \text{CO}_2(\text{g}) \quad \Delta H = -283 \text{ kJ}$
- d**  $\text{N}_2(\text{g}) + 2\text{O}_2(\text{g}) \rightleftharpoons 2\text{NO}(\text{g}) \quad \Delta H = +180 \text{ kJ mol}^{-1}$
- e**  $2\text{NO}_2(\text{g}) \rightleftharpoons 2\text{NO}(\text{g}) + \text{O}_2(\text{g}) \quad \Delta H = -114 \text{ kJ mol}^{-1}$

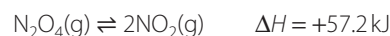
- 7 What will happen to each of these systems if you (i) increase or (ii) decrease the pressure on the system? Each is in a closed system.

- a**  $4\text{NH}_3(\text{g}) + 5\text{O}_2(\text{g}) \rightleftharpoons 4\text{NO}(\text{g}) + 6\text{H}_2\text{O}(\text{g})$
- b**  $\text{SO}_2(\text{g}) + \text{O}_2(\text{g}) \rightleftharpoons 2\text{SO}_3(\text{g})$
- c**  $4\text{NH}_3(\text{g}) + 3\text{O}_2(\text{g}) \rightleftharpoons 2\text{N}_2(\text{g}) + 6\text{H}_2\text{O}(\text{g})$
- d**  $2\text{NO}_2(\text{g}) \rightleftharpoons 2\text{NO}(\text{g}) + \text{O}_2(\text{g})$

- 8 Use collision theory to explain the effect of removing hydronium ions ( $\text{H}_3\text{O}^+$ ) from the following reaction mixture at equilibrium.



- 9 For the reaction:



what would be the effect of each of the following changes on an equilibrium mixture of  $\text{N}_2\text{O}_4$  and  $\text{NO}_2$ ?

- a** Adding  $\text{N}_2\text{O}_4(\text{g})$
- b** Adding  $\text{NO}_2(\text{g})$
- c** Adding heat
- d** Removing  $\text{N}_2\text{O}_4(\text{g})$
- e** Increasing the pressure

- 10 A closed system consisting of a mixture of the gases  $\text{CO}$ ,  $\text{Cl}_2$  and  $\text{COCl}_2$  was monitored over time (Figure 2.22).

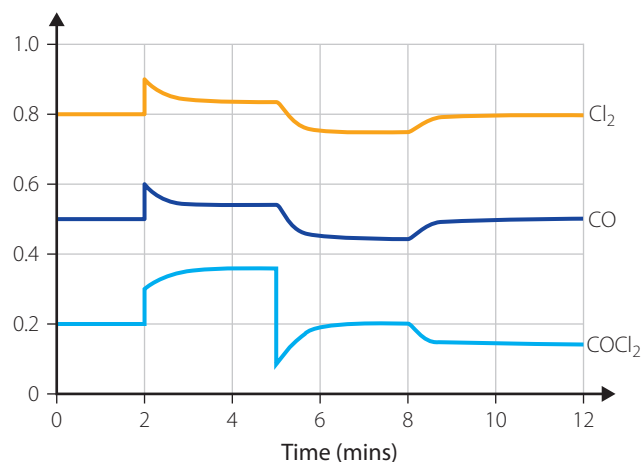


FIGURE 2.22 Closed system of a mixture of gases

- a** When was the system at equilibrium?
- b** What change occurred at 5 minutes?
- c** Explain, with reference to Le Chatelier's principle, what happened between 2 and 4 minutes.
- d** At  $t = 8$  mins, the temperature of the system was increased. With reference to the graph, justify whether the synthesis of  $\text{COCl}_2$  is an endothermic or exothermic process.



- 11 The graph in Figure 2.23 shows the concentration of the reactant and product for the reaction:

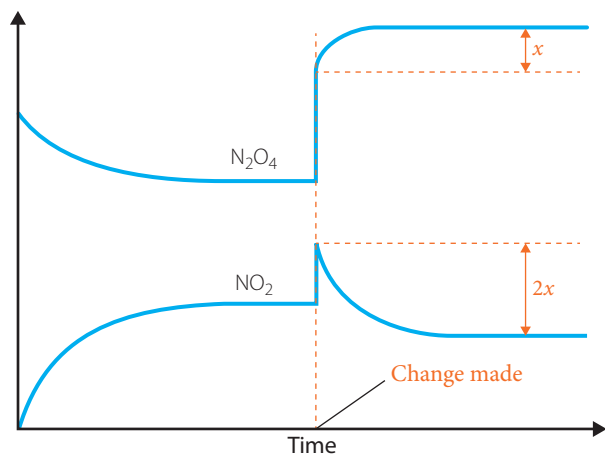
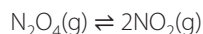
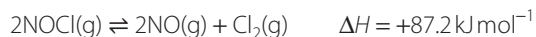


FIGURE 2.23 Concentration of  $\text{N}_2\text{O}_4$  and  $\text{NO}_2$  over time

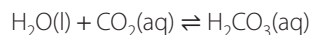
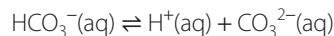
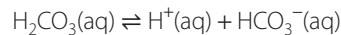
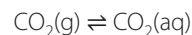
Use Le Chatelier's principle to explain the change seen in the graph.

- 12 The equation for the decomposition of nitrosyl chloride is given below.

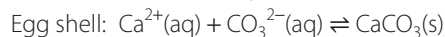
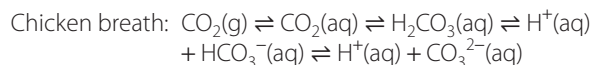


- Explain, in terms of Le Chatelier's principle, the effect of decreasing the volume of the system.
- Explain, in terms of collision theory, the effect of decreasing the volume of the system.

- 13 Chickens cannot perspire, so when they get hot they pant. In hot weather, chickens lay eggs with thin shells that are easily broken. The following equilibrium system exists:



Overall:



- Explain why panting causes weaker egg shells.
- To overcome this problem, farmers gave chickens carbonated water. Explain how this can overcome the problem of weak egg shells.

- 14 Determine whether  $\text{NH}_4\text{NO}_3(\text{s})$  will spontaneously dissolve in water at 298 K using the reaction:



Data: (under standard conditions, i.e. at 298 K)

SPECIES	$\text{NH}_4\text{NO}_3(\text{s})$	$\text{NH}_4^+(\text{aq})$	$\text{NO}_3^-(\text{aq})$
ENTHALPY OF FORMATION ( $\text{kJ mol}^{-1}$ )	-365.56	-132.51	-205.0
ENTROPY ( $\text{JK}^{-1}\text{mol}^{-1}$ )	151.08	113.4	146.4

- 15 Research the role equilibrium plays in the transport of oxygen in blood.

## 3

## Calculating the equilibrium constant

## INQUIRY QUESTION

How can the position of equilibrium be described and what does the equilibrium constant represent?

## Students:

deduce the equilibrium expression (in terms of  $K_q$ ) for homogeneous reactions occurring in solution (ACSCH07, ACSCH96) ICT N

perform calculations to find the value of  $K_q$  and concentrations of substances within an equilibrium system, and use these values to make predictions on the direction in which a reaction may proceed (ACSCH09) ICT N

qualitatively analyse the effect of temperature on the value of  $K_q$  (ACSCH09) ICT N

conduct an investigation to determine  $K_q$  of a chemical equilibrium system, for example:

–  $K_q$  of the iron(III) thiocyanate equilibrium (ACSCH09) ICT

explore the use of  $K_q$  for different types of chemical reactions, including but not limited to:

- dissociation of ionic solutions
- dissociation of acids and bases. (ACSCH09, ACSCH99)

Chemistry Stage 6 Syllabus © NSW Educational Standard Authority for and on behalf of the Crown in right of the State of New South Wales, 2017





Prior knowledge



**FIGURE 3.1** Nitrogen dioxide at different temperatures

In chapter 2, the focus was on interpreting equilibrium systems descriptively. However, it is important to not just understand the effect of changes descriptively but also to quantify them (i.e. Is the effect large? If so how large? If small, how small?) Understanding the quantifiable effects of changes in concentration, pressure and temperature on equilibrium systems is important in industry because chemists need to ensure that they are making the products in the most efficient and cost-effective way possible. Industrial applications of equilibrium, such as the production of ammonia and sulfuric acid, will be

covered in chapter 16 ('Chemical synthesis and design'). However, before you can look at industrial applications, you need to understand the numerical treatment of equilibrium systems.

## 3.1 Equilibrium constant

Just like a balanced see-saw at equilibrium, a chemical system at equilibrium has a balance between the reactants and products. For a chemical system in equilibrium there is a mathematical relationship between the concentrations of the reactants and products. This relationship is known as the **equilibrium constant** or  $K$  or  $K_{eq}$ . The equilibrium constant is a numerical value based on the ratio between the products and reactants in a specific reaction at a specific temperature when the system has reached equilibrium. In general terms, it can be written as:

$$K_{eq} = \frac{[\text{products}]}{[\text{reactants}]} \quad \dots (3.1)$$

More specifically, it can be calculated from the concentrations of the reactants and products at equilibrium in the **equilibrium expression**.

For the reaction:



the equilibrium expression is:

$$K_{eq} = \frac{[C]^c [D]^d}{[A]^a [B]^b} \quad \dots (3.3)$$

Since the equilibrium expression is determined from the way the equation is written, the magnitude of  $K_{eq}$  will also depend on the equation for the specific chemical reaction.

# INVESTIGATION 3.1

## Calculating the equilibrium expression



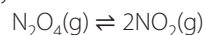
Numeracy



Critical and creative thinking

### INTRODUCTION

In Investigation 2.4, the following equilibrium system was observed:



You described whether the colour of the gases inside the syringe became lighter or darker when the volume of the system was changed.

You are not able to collect first-hand data about concentrations in gaseous systems; therefore, start with a familiar reaction then progress to other gaseous systems.

In this investigation, you will perform data analysis based on the quantitative data provided for three different gaseous systems. Assume that all reactions occurred at the same temperature.

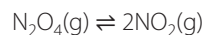
### AIM

To develop an understanding of the equilibrium constant.

### METHOD

Complete the following in order.

- 1 Consider the reaction where dinitrogen tetraoxide forms nitrogen dioxide:



At equilibrium, the following concentrations were recorded. Remember that square brackets indicate concentration in  $\text{mol L}^{-1}$ .

- a Copy and complete the table.

TRIAL	$[\text{N}_2\text{O}_4]$ ( $\text{mol L}^{-1}$ )	$[\text{NO}_2]$ ( $\text{mol L}^{-1}$ )	$[\text{N}_2\text{O}_4]^2$	$[\text{NO}_2]^2$	$\frac{[\text{NO}_2]}{[\text{N}_2\text{O}_4]}$	$\frac{[\text{NO}_2]^2}{[\text{N}_2\text{O}_4]}$	$\frac{[\text{NO}_2]}{[\text{N}_2\text{O}_4]^2}$
1	3.476	1.048					
2	2.56	0.899					
3	0.830	0.512					
4	0.0123	0.0623					

- b Which column has a consistent pattern?
  - c Explain whether the column with the consistent pattern is consistent with the equilibrium expression for the decomposition of dinitrogen tetraoxide to form nitrogen dioxide.
- 2 Consider the reaction:

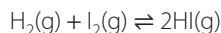


- a Copy and complete the table using the equilibrium concentrations listed.

TRIAL	$[\text{PCl}_5]$ ( $\text{mol L}^{-1}$ )	$[\text{PCl}_3]$ ( $\text{mol L}^{-1}$ )	$[\text{Cl}_2]$ ( $\text{mol L}^{-1}$ )	$\frac{[\text{PCl}_3]}{[\text{PCl}_5][\text{Cl}_2]}$	$\frac{[\text{PCl}_3][\text{Cl}_2]}{[\text{PCl}_5]}$
1	2.30	0.971	0.971		
2	0.62	1.69	0.15		
3	1.05	0.41	1.05		
4	0.0292	3.75	3.75		
5	5.90	1.56	1.55		



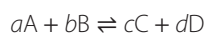
- » **b** Which column has a consistent pattern?  
**c** Explain whether the column with the consistent pattern is consistent with the equilibrium expression for the reaction given above for the decomposition of phosphorus pentachloride.
- 3** Consider the reaction between hydrogen and iodine producing hydrogen iodide:



- a** Reflect on the patterns you have seen in the first two questions to predict the relationship that will exist in this reaction.  
**b** Use the equilibrium concentrations below to test your prediction.

TRIAL	$[\text{H}_2]$ (mol L <sup>-1</sup> )	$[\text{I}_2]$ (mol L <sup>-1</sup> )	$[\text{HI}]$ (mol L <sup>-1</sup> )
1	2.5	2.5	17.7
2	0.226	0.226	1.6
3	1.25	3.00	13.7
4	0.015	0.020	0.122

- c** Explain whether or not your prediction was correct.
- 4** Summarise your findings for calculating the equilibrium constant using the following general equation:



## What is included in the equilibrium expression?

The equilibrium constant is a numerical value based on the ratio of the concentration of reactants and products. If the species is in a state where the concentration can vary, it is included in the expression; however, if it is in a pure state its concentration is constant so this concentration is not always included in the equilibrium expression.

Solutions vary in concentration and are therefore included in the equilibrium expression. Gases also vary in concentration and are included. The partial pressure (the pressure of the individual gas) is proportional to the concentration of the gas and therefore can also be used in the equilibrium expression for a gaseous system.

However, solids and pure liquids do not vary in their concentration. Therefore, in a heterogeneous system where the substances are in more than one phase, solids and liquids are not included in the equilibrium expression. In a homogeneous system, where all substances are in the same phase, solids and liquids are included because the relative proportions are important.

## Reaction quotient ( $Q$ )

For the reaction:



the expression,  $\frac{[\text{C}]^c [\text{D}]^d}{[\text{A}]^a [\text{B}]^b}$ , is always written with the:

- products placed in the numerator (i.e. species on the right-hand side of equation 3.4 as written)
- reactants placed in the denominator (i.e. species on the left-hand side of equation 3.4 as written)
- concentration of each chemical species is raised to the power corresponding to the number of moles of that species indicated in the balanced chemical equation (for example, in equation 3.4, there are  $d$  moles of species D; hence, in the equilibrium expression the concentration of species D is raised to the power of  $d$ ). It is written as  $[\text{D}]^d$ .



The equilibrium constant ( $K_{eq}$ ) can only be used for a chemical reaction if the concentrations of the chemical species are measured for that reaction when it has reached equilibrium. If the concentrations of the chemical species are measured for a reaction that has not reached equilibrium, then the symbol  $Q$  is used.  $Q$  is called the **reaction quotient**. This indicates the ratio of products to reactants for any chemical system. Hence,  $Q$  is a more general term than  $K_{eq}$ , which is only used where the system is at equilibrium.

### WORKED EXAMPLE 3.1



Numeracy



Critical and creative thinking

- Write the equilibrium expression for  $3\text{H}_2(\text{g}) + \text{N}_2(\text{g}) \rightleftharpoons 2\text{NH}_3(\text{g})$ .
- Write the equilibrium expression for  $\text{CaCl}_2(\text{s}) \rightleftharpoons \text{Ca}^{2+}(\text{aq}) + 2\text{Cl}^{-}(\text{aq})$ .

ANSWER	LOGIC
<p>1 <math>K_{eq} = \frac{\text{NH}_3}{\text{H}_2\text{N}_2}</math></p> <p><math>K_{eq} = \frac{[\text{NH}_3]}{[\text{H}_2][\text{N}_2]}</math></p> <p><math>K_{eq} = \frac{[\text{NH}_3]^2}{[\text{H}_2]^3 [\text{N}_2]}</math></p> <p><math>K_{eq} = \frac{[\text{NH}_3]^2}{[\text{H}_2]^3 \times [\text{N}_2]}</math></p>	<ul style="list-style-type: none"> <li>Put the products on top of the expression; put the reactants underneath.</li> <li>Check to see if any of the species are solids or pure liquids. If so, delete them from the expression.</li> <li>Add square brackets around each substance to indicate concentration.</li> <li>The coefficient for each species from the balanced equation becomes the power in the expression.</li> <li>Multiply concentrations if there is more than one reactant or product.</li> </ul>
<p>2 <math>K_{eq} = \frac{\text{Ca}^{2+} \text{Cl}^{-}}{\text{CaCl}_2}</math></p> <p><math>K_{eq} = \text{Ca}^{2+} \text{Cl}^{-}</math></p> <p><math>K_{eq} = \frac{[\text{Ca}^{2+}] \text{Cl}^{-}}{[\text{CaCl}_2]}</math></p> <p><math>K_{eq} = \frac{[\text{Ca}^{2+}] \text{Cl}^{-}^2}{[\text{CaCl}_2]}</math></p> <p><math>K_{eq} = \frac{[\text{Ca}^{2+}] \times \text{Cl}^{-}^2}{[\text{CaCl}_2]}</math></p>	<ul style="list-style-type: none"> <li>Put the products on top and the reactants on bottom.</li> <li>Exclude solids and liquids in heterogeneous equilibria.</li> <li>Add square brackets around each substance to indicate concentration.</li> <li>The coefficient for each species from the equation becomes the power in the expression.</li> <li>Multiply concentrations if there is more than one reactant or product.</li> </ul>

#### TRY THESE YOURSELF

Write the equilibrium expression for each of the following reactions.

- $2\text{SO}_2(\text{g}) + \text{O}_2(\text{g}) \rightleftharpoons 2\text{SO}_3(\text{g})$
- $\text{H}_2\text{O}(\text{g}) + \text{C}(\text{s}) \rightleftharpoons \text{H}_2(\text{g}) + \text{CO}(\text{g})$
- $\text{CaCO}_3(\text{s}) \rightleftharpoons \text{CaO}(\text{s}) + \text{O}_2(\text{g})$
- $\text{HSO}_4^{-}(\text{aq}) + \text{H}_2\text{O}(\text{l}) \rightleftharpoons \text{H}_3\text{O}^{+}(\text{aq}) + \text{SO}_4^{2-}(\text{aq})$
- $2\text{CrO}_4^{2-}(\text{aq}) + 2\text{H}^{+}(\text{aq}) \rightleftharpoons \text{Cr}_2\text{O}_7^{2-}(\text{aq}) + \text{H}_2\text{O}(\text{l})$



## Using $Q$ to determine equilibrium

$Q$  can be used to determine whether or not a system is at equilibrium. Therefore, if  $Q = K_{eq}$  then the system is at equilibrium.

If  $Q < K_{eq}$ , then there are less products (the numerator is smaller) and more reactants (the denominator is larger) than at equilibrium. This indicates that the forward reaction will be favoured for the system to reach equilibrium. Conversely, if  $Q > K_{eq}$ , then there are more products and less reactants than at equilibrium. This indicates that the reverse reaction will be favoured for the system to reach equilibrium.

- If  $Q < K_{eq}$ , the forward reaction will be favoured to reach equilibrium.
- If  $Q > K_{eq}$ , the reverse reaction will be favoured to reach equilibrium.
- If  $Q = K_{eq}$ , then the system is at equilibrium.

## Size of the equilibrium constant

The magnitude of  $K_{eq}$  can tell us whether there are more products or reactants in a system at equilibrium. As the products are in the numerator of the equilibrium expression, a large value of  $K_{eq}$  indicates the concentration of products is much greater than the concentration of reactants. Therefore:

- a large value of  $K_{eq}$  indicates that the reaction goes towards completion, meaning that nearly all of the reactants become products; thus, equilibrium lies to the right, since there are more products present at equilibrium than reactants
- a small value of  $K_{eq}$  indicates that the reaction only occurs to a small extent; thus, equilibrium lies to the left, since there are more reactants than products at equilibrium
- a value of  $K_{eq}$  close to 1 indicates that there are significant concentrations of both reactants and products present at equilibrium.

- Equilibrium constants predict the relative concentrations of products and reactants and therefore the position of equilibrium.
- f  $K_{eq} > 1$ , the equilibrium lies to the right.
- f  $K_{eq} < 1$ , the equilibrium lies to the left.

For example, the equilibrium constant for the pop test, which is the reaction between hydrogen gas and oxygen gas to form water vapour, is  $2.4 \times 10^{47}$  at 500 K.

The equation for this reaction is:

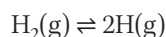


Therefore, the equilibrium expression is:

$$K_{eq} = \frac{[\text{H}_2\text{O}]^2}{[\text{H}_2]^2[\text{O}_2]} \quad \dots (3.6)$$

The high value of the equilibrium constant shows that, at equilibrium, there is a large amount of products ( $\text{H}_2\text{O}$ ) and only a very small amount of reactants ( $\text{H}_2$  and  $\text{O}_2$ ). This indicates that most of the reactants become products, so the reaction occurs to a large extent. In this case, the position of equilibrium is to the right.

Alternatively, the reaction for hydrogen molecules splitting into hydrogen atoms has an equilibrium constant of  $1.2 \times 10^{-42}$  at 500 K.



$$K_{eq} = \frac{[\text{H}]^2}{[\text{H}_2]}$$

The very low value for the equilibrium constant indicates that, at equilibrium, there is a large proportion of the reactant ( $\text{H}_2$  molecules) compared to the product (H atoms). This shows that the reaction only occurs to a small extent. In this case, the position of equilibrium is to the left.

The equilibrium expression is always written for the balanced equation as it appears in the text. Equation 3.5 involved the equilibrium reaction between hydrogen, oxygen and water vapour. It was written as the synthesis of water vapour from hydrogen and oxygen since the hydrogen and oxygen were on the left side and water vapour was on the right side. However, the equation could also be written as a decomposition reaction, namely:



where water is written on the left side and hydrogen and oxygen are written on the right side.

Since the equation has changed, so too will the equilibrium expression. The equilibrium expression for equation 3.7 is:

$$K_{eq} = \frac{[\text{H}_2]^2[\text{O}_2]}{[\text{H}_2\text{O}]^2} \quad \dots (3.8)$$

The equilibrium expression given in equation 3.8 is the inverse of the equilibrium expression in equation 3.6. This also means the value of the equilibrium constant will be the inverse of the value for the opposite reaction.



The equilibrium expression

$$K_{eq} \text{ for expression 3.8} = \frac{1}{K_{eq} \text{ for expression 3.6}} = \frac{1}{1.2 \times 10^{-42}} = 83 \times 10^{41}$$

- When the chemical equation is reversed, the equilibrium expression is inverted.

## Units for equilibrium constants

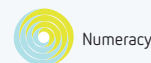
Equilibrium constants are generally reported as numbers without units. This is the case in the NSW HSC examinations. However, the concentrations for all species in the equilibrium expression must be in  $\text{mol L}^{-1}$ . If concentrations are expressed in other units, they must be converted to  $\text{mol L}^{-1}$  prior to substituting in the reaction quotient.

### WORKED EXAMPLE (3.2)

- 1 Example 1: Calculating an equilibrium constant. Calculate the magnitude of the equilibrium constant for the reaction:



given that, at equilibrium,  $[\text{CH}_3\text{COOH}] = 0.92 \text{ mol L}^{-1}$ ,  $[\text{CH}_3\text{COO}^-] = 1.62 \times 10^{-2} \text{ mol L}^{-1}$  and  $[\text{H}^+] = 1.02 \times 10^{-3} \text{ mol L}^{-1}$ .



Numeracy



Critical and creative thinking

ANSWER	LOGIC
$K_{eq} = \frac{[\text{CH}_3\text{COO}^-] \times [\text{H}^+]}{[\text{CH}_3\text{COOH}]}$	<ul style="list-style-type: none"> <li>Write the equilibrium expression.</li> </ul>
$K_{eq} = \frac{[\text{CH}_3\text{COO}^-] \times [\text{H}^+]}{[\text{CH}_3\text{COOH}]}$	<ul style="list-style-type: none"> <li>Substitute the given concentrations into the expression.</li> </ul>
$K_{eq} = 1.8 \times 10^{-5}$	<ul style="list-style-type: none"> <li>Calculate the answer.</li> </ul>

- 2 Example 2: Effect of changed reaction conditions on the equilibrium constant. At 458°C, the equilibrium constant for the reaction  $2\text{HI}(\text{g}) \rightleftharpoons \text{H}_2(\text{g}) + \text{I}_2(\text{g})$  is 0.0201. What is the equilibrium constant for the reaction  $\text{HI}(\text{g}) \rightleftharpoons \frac{1}{2}\text{H}_2(\text{g}) + \frac{1}{2}\text{I}_2(\text{g})$  at 458°C?

ANSWER	LOGIC
$K_{eq} = \frac{[\text{H}_2][\text{I}_2]}{[\text{HI}]^2}$	<ul style="list-style-type: none"> <li>Write the equilibrium expression for the original reaction.</li> </ul>
$K_{eq} = \frac{[\text{H}_2]^{\frac{1}{2}}[\text{I}_2]^{\frac{1}{2}}}{[\text{HI}]}$	<ul style="list-style-type: none"> <li>Write the equilibrium expression for the second reaction.</li> </ul>
$K_{eq \text{ 2nd equation}} = \sqrt{K_{eq \text{ original equation}}}$	<ul style="list-style-type: none"> <li>Compare the equilibrium expression for the second reaction to the equilibrium expression for the original reaction.</li> </ul>
$K_{eq \text{ 2nd equation}} = \sqrt{0.0201} = 0.142$	<ul style="list-style-type: none"> <li>Perform the same operation to the original equilibrium constant.</li> </ul>

#### TRY THESE YOURSELF

- Calculate the magnitude of the equilibrium constant for each of the following examples at equilibrium.
  - $\text{CO}_2(\text{g}) + \text{H}_2(\text{g}) \rightleftharpoons \text{CO}(\text{g}) + \text{H}_2\text{O}(\text{g})$ , given that  $[\text{CO}_2] = 2.00 \text{ mol L}^{-1}$ ,  $[\text{H}_2] = 3.00 \text{ mol L}^{-1}$ ,  $[\text{CO}] = [\text{H}_2\text{O}] = 0.17 \text{ mol L}^{-1}$ .
  - $2\text{H}_2\text{S}(\text{g}) \rightleftharpoons 2\text{H}_2(\text{g}) + \text{S}_2(\text{g})$ , given that  $[\text{H}_2\text{S}] = 0.2 \text{ mol L}^{-1}$ ,  $[\text{H}_2] = 7.0 \times 10^{-3} \text{ mol L}^{-1}$  and  $[\text{S}_2] = 3.5 \times 10^{-3} \text{ mol L}^{-1}$ .
- The equilibrium constant for  $\text{N}_2(\text{g}) + 3\text{H}_2(\text{g}) \rightleftharpoons 2\text{NH}_3(\text{g})$  at 400°C is 39. Calculate the equilibrium constant for  $4\text{N}_2(\text{g}) + 12\text{H}_2(\text{g}) \rightleftharpoons 8\text{NH}_3(\text{g})$ .

#### CHECK YOUR UNDERSTANDING

3.1



Numeracy



Critical and creative thinking

- Write the equilibrium expression for each of the following reactions.
  - $\text{Ag}^+(\text{aq}) + 2\text{NH}_3(\text{aq}) \rightleftharpoons \text{Ag}(\text{NH}_3)_2^+(\text{aq})$
  - $\text{I}_2(\text{aq}) + \text{Cl}_2(\text{aq}) \rightleftharpoons 2\text{ICl}(\text{aq})$
  - $\text{HCOOCH}_3(\text{aq}) + \text{H}_2\text{O}(\text{l}) \rightleftharpoons \text{HCOOH}(\text{aq}) + \text{CH}_3\text{OH}(\text{aq})$
  - $\text{CO}(\text{g}) + 2\text{H}_2(\text{g}) \rightleftharpoons \text{CH}_3\text{OH}(\text{g})$
  - $\text{CO}(\text{g}) + \text{H}_2\text{O}(\text{g}) \rightleftharpoons \text{CO}_2(\text{g}) + \text{H}_2(\text{g})$
  - $2\text{NO}(\text{g}) + \text{Cl}_2(\text{g}) \rightleftharpoons 2\text{NOCl}(\text{g})$
  - $\text{H}_2\text{O}(\text{g}) + \text{C}(\text{s}) \rightleftharpoons \text{H}_2(\text{g}) + \text{CO}(\text{g})$
- The equilibrium constant for  $\text{Br}_2(\text{aq}) + \text{Br}^-(\text{aq}) \rightleftharpoons \text{Br}_3^-(\text{aq})$  at 25°C is 18. Calculate the equilibrium constant for  $\text{Br}_3^-(\text{aq}) \rightleftharpoons \text{Br}_2(\text{aq}) + \text{Br}^-(\text{aq})$
  - For the reaction  $\text{PCl}_5(\text{g}) \rightleftharpoons \text{PCl}_3(\text{g}) + \text{Cl}_2(\text{g})$  the equilibrium constant is 0.040 at 252°C. Calculate the equilibrium constant for  $\text{PCl}_3(\text{g}) + \text{Cl}_2(\text{g}) \rightleftharpoons \text{PCl}_5(\text{g})$
- For the reaction  $\text{N}_2(\text{g}) + 3\text{H}_2(\text{g}) \rightleftharpoons 2\text{NH}_3(\text{g})$  the equilibrium constant at 400°C is 39. Calculate the equilibrium constant for  $\frac{1}{2}\text{N}_2(\text{g}) + \frac{3}{2}\text{H}_2(\text{g}) \rightleftharpoons \text{NH}_3(\text{g})$
- At 300K, the equilibrium constant for  $\text{NO}_2(\text{g}) \rightleftharpoons \frac{1}{2}\text{N}_2\text{O}_4(\text{g})$  is  $5.0 \times 10^{-3}$ . Calculate the equilibrium constant for  $\text{N}_2\text{O}_4(\text{g}) \rightleftharpoons 2\text{NO}_2(\text{g})$

## 3.2

## Measuring equilibrium constants

To determine the equilibrium constant for a particular chemical reaction, the following is needed:

- ▶ the equation for the reaction
- ▶ the equilibrium expression
- ▶ then *either*:
  - the initial concentrations of all chemical species put into the reaction vessel
 and
  - the equilibrium concentration of one of the chemical species; the reaction stoichiometry can then be used to calculate the concentrations of the other species at equilibrium
- ▶ *or*
  - the equilibrium concentrations for all chemical species.

### WORKED EXAMPLE 3.3

All equilibrium concentrations are given in the question.

- 1 Carbon monoxide gas reacts with hydrogen gas to form methanol gas according to the following equation:



At 373 K, the equilibrium mixture contained  $2.54 \times 10^{-3} \text{ mol L}^{-1}$  CO,  $3.75 \times 10^{-3} \text{ mol L}^{-1}$  H<sub>2</sub> and  $2.14 \times 10^{-8} \text{ mol L}^{-1}$  CH<sub>3</sub>OH.

Calculate the equilibrium constant for the synthesis of methanol at 373 K.



ANSWER	LOGIC
$[\text{CO}] = 2.54 \times 10^{-3} \text{ mol L}^{-1}$ $[\text{H}_2] = 3.75 \times 10^{-3} \text{ mol L}^{-1}$ $[\text{CH}_3\text{OH}] = 2.143 \times 10^{-8} \text{ mol L}^{-1}$	<ul style="list-style-type: none"> <li>▪ Extract the data from the question.</li> <li>▪ <b>Note:</b> The equilibrium concentrations were given for all chemical species.</li> </ul>
$K_{eq} = \frac{[\text{CH}_3\text{OH}]}{[\text{CO}][\text{H}_2]^2}$	<ul style="list-style-type: none"> <li>▪ Write the equilibrium expression.</li> </ul>
$K_{eq} = \frac{[2.14 \times 10^{-8}]}{[2.54 \times 10^{-3}][3.75 \times 10^{-3}]^2}$	<ul style="list-style-type: none"> <li>▪ Substitute data into the equilibrium expression.</li> </ul>
$K_{eq} = 0.600$	<ul style="list-style-type: none"> <li>▪ Solve for <math>K_{eq}</math></li> <li>▪ Answer to three significant figures since all data in the question is given to three significant figures.</li> </ul>

- 2 0.0200 mol of phosphorus pentachloride was placed in a 2.00 L flask at 250°C. It reacted to form an equilibrium mixture according to the following equation:



At equilibrium, the concentration of phosphorus trichloride was 0.0083 mol L<sup>-1</sup>.

Calculate the equilibrium constant for the decomposition of phosphorus pentachloride at 250°C.

ANSWER	LOGIC															
<p>Number of moles of PCl<sub>5</sub> = 0.0200 mol</p> <p>Volume of reaction vessel = 2.00 L</p> $[\text{PCl}_5] = \frac{n}{V} = \frac{0.0200}{2.00} = 0.0100 \text{ mol L}^{-1}$ $[\text{PCl}_3] = 0$ $[\text{Cl}_2] = 0$	<ul style="list-style-type: none"> <li>Extract data for initial conditions and convert to concentrations for each species.</li> <li>Initially, there was only PCl<sub>5</sub> in the reaction vessel, and hence, no PCl<sub>3</sub> or Cl<sub>2</sub> present.</li> </ul>															
<p><math>[\text{PCl}_3] = 0.0083 \text{ mol L}^{-1}</math></p> <p><math>[\text{Cl}_2] = [\text{PCl}_3] = 0.0083 \text{ mol L}^{-1}</math></p> <p>1 mole of phosphorus trichloride and 1 mole of chlorine. Hence, the concentration of Cl<sub>2</sub> formed is the same as the concentration of PCl<sub>3</sub> formed.</p> $[\text{PCl}_5] = 0.0100 - 0.0083 = 0.0017 \text{ mol L}^{-1}$ <p>The PCl<sub>5</sub> decomposed to form the Cl<sub>2</sub> and PCl<sub>3</sub>. Therefore, the concentration of PCl<sub>5</sub> remaining at equilibrium is calculated by subtracting the amount that converted to Cl<sub>2</sub> and PCl<sub>3</sub> from the initial concentration of PCl<sub>5</sub>.</p>	<ul style="list-style-type: none"> <li>Calculate the equilibrium concentrations of each of the chemical species.</li> <li>Data for equilibrium concentration of PCl<sub>3</sub> was given in the question.</li> <li>Look at the equation and use reaction stoichiometry. 1 mole of phosphorus pentachloride decomposes to form</li> <li>Calculate the remaining concentration at equilibrium.</li> </ul>															
<table style="width: 100%; border-collapse: collapse;"> <tr> <td style="text-align: center;"><math>\text{PCl}_5(\text{g})</math></td> <td style="text-align: center;"><math>\rightleftharpoons</math></td> <td style="text-align: center;"><math>\text{PCl}_3(\text{g})</math></td> <td style="text-align: center;"><math>+</math></td> <td style="text-align: center;"><math>\text{Cl}_2(\text{g})</math></td> </tr> <tr> <td style="text-align: center;">Initial conc: 0.0100</td> <td></td> <td style="text-align: center;">0</td> <td></td> <td style="text-align: center;">0</td> </tr> <tr> <td style="text-align: center;">Equil conc: 0.0100 – 0.0083</td> <td></td> <td style="text-align: center;">0.0083</td> <td></td> <td style="text-align: center;">0.0083</td> </tr> </table>	$\text{PCl}_5(\text{g})$	$\rightleftharpoons$	$\text{PCl}_3(\text{g})$	$+$	$\text{Cl}_2(\text{g})$	Initial conc: 0.0100		0		0	Equil conc: 0.0100 – 0.0083		0.0083		0.0083	<ul style="list-style-type: none"> <li>A simpler way for this to be shown is by writing the chemical equation, then writing the initial and equilibrium concentrations underneath.</li> </ul>
$\text{PCl}_5(\text{g})$	$\rightleftharpoons$	$\text{PCl}_3(\text{g})$	$+$	$\text{Cl}_2(\text{g})$												
Initial conc: 0.0100		0		0												
Equil conc: 0.0100 – 0.0083		0.0083		0.0083												
$K_{eq} = \frac{[\text{PCl}_3][\text{Cl}_2]}{[\text{PCl}_5]}$	<ul style="list-style-type: none"> <li>Write the equilibrium expression.</li> </ul>															
$K_{eq} = \frac{0.0083 \times 0.0083}{0.0017}$	<ul style="list-style-type: none"> <li>Substitute the equilibrium concentrations for each species into the equilibrium expression.</li> </ul>															
$K_{eq} = 0.041$	<ul style="list-style-type: none"> <li>Solve for <math>K_{eq}</math></li> <li>Answer is written to two significant figures since it is given to the least number of significant figures for the data given in the question.</li> <li>Least number of significant figures was two significant figures; hence, that is the number of significant figures to which the answer is reported.</li> </ul>															

### TRY THESE YOURSELF

- 1 The reaction for the decomposition of nitrosyl chloride to form nitric oxide and chlorine is given in the following equation:



A mixture of these gases was placed in the reaction vessel at 738 K and over time, it reached equilibrium. The concentrations of the gases at equilibrium were:

$[\text{NOCl}]$  was  $2.07 \times 10^{-4} \text{ mol L}^{-1}$ ,  $[\text{NO}]$  was  $5.24 \times 10^{-3} \text{ mol L}^{-1}$  and  $[\text{Cl}_2]$  was  $1.43 \times 10^{-4} \text{ mol L}^{-1}$ . Calculate the equilibrium constant for the dissociation of nitrosyl chloride at 738 K.

- 2 The gases carbon dioxide and carbon tetrafluoride ( $\text{CF}_4$ ) are formed when carbon oxyfluoride gas ( $\text{COF}_2$ ) decomposes. 1.0 mol of carbon oxyfluoride is initially placed in the 5.0 L reaction vessel at 473 K. At equilibrium, there is only 0.040 mol of carbon oxyfluoride remaining in the reaction vessel.
- Write an equation for the decomposition of carbon oxyfluoride.
  - Calculate the equilibrium constant for the decomposition of carbon oxyfluoride at 473 K.

When measuring equilibrium concentrations, it is important that the measurement technique does not cause a change in the concentrations as the measurements are being undertaken. Hence, techniques such as using colourimeters and pH meters are used since they do not interfere with the reaction in any way. They are non-destructive measuring techniques.

## INVESTIGATION 3.2

### Using colourimetry to determine an equilibrium constant

#### INTRODUCTION

Colourimetry is a quantitative technique used to measure the difference in the darkness or lightness of the colour of a solution. Coloured solutions absorb light; hence, more light enters the solution than exits it. The amount of light absorbed by the solution is called the absorbance. This is related to the concentration of the solution. The greater the concentration, the greater the absorbance. The Beer–Lambert law states the quantitative relationship between absorbance and concentration:

$$A = \epsilon lc$$

where:

- $A$  is absorbance – it does not have units since it is a  $\log_{10}$  of the ratio between the light entering and light exiting the solution.
- $\epsilon$  is the molar absorptivity. It is a constant for a particular chemical. It is a measure of the amount of light that a solution containing that chemical absorbs per unit of concentration. The units for molar absorptivity are  $\text{L mol}^{-1} \text{ cm}^{-1}$ .
- $l$  is the path length of the light through the sample. The path length is measured in cm. In this investigation, you will be using a cuvette with a diameter of 1 cm (hence,  $l$  is 1 cm).
- $c$  is the concentration of the solution. The units for concentration are  $\text{mol L}^{-1}$ .

Since  $\epsilon$  and  $l$  are constants during the investigation, the Beer–Lambert law indicates that there is a direct relationship between absorbance and concentration:

$$A \propto c$$



Numeracy



Critical and creative thinking



Information and communication technology capability





## » AIM

To use colourimetry to determine the equilibrium constant for the reaction of iron(III) ions with thiocyanate ions to form the iron(III) thiocyanate ion.

## MATERIALS

- 200 mL 0.2 mol L<sup>-1</sup> Fe(NO<sub>3</sub>)<sub>3</sub>
- 100 mL 0.002 mol L<sup>-1</sup> KSCN
- 500 mL 0.5 mol L<sup>-1</sup> HNO<sub>3</sub>
- 60 mL 0.002 mol L<sup>-1</sup> Fe(NO<sub>3</sub>)<sub>3</sub>
- 150 mL distilled water
- 6 × 100 mL volumetric flasks
- 5 × 150 mL beakers
- 2 × 100 mL beakers
- 1 × 25 mL bulb pipette
- 2 × 10 mL graduated pipettes
- 1 × 10 mL bulb pipette
- 2 pipette bulbs
- 1 disposable pipette
- Waste bottle
- 14 small labels
- 1 colourimeter and set of cuvettes
- Safety glasses



WHAT ARE THE RISKS IN DOING THIS INVESTIGATION?	HOW CAN YOU MANAGE THESE RISKS TO STAY SAFE?
Chemicals may splash onto your skin or into your eyes.	Wear safety glasses and wash your hands at the end of the experiment.
FeSCN <sup>2+</sup> is harmful to aquatic life.	Do not pour down the sink. Pour into the waste bottle provided.

What other risks are associated with your investigation? How can you manage these?

## PART A

### METHOD

- Label the six volumetric flasks A–F.
- Use a 25 mL bulb pipette to transfer 25.00 mL of the 0.200 mol L<sup>-1</sup> Fe(NO<sub>3</sub>)<sub>3</sub> to flask A.
- Use a graduated 10 mL pipette to transfer 1.00 mL of the 0.002 mol L<sup>-1</sup> KSCN to flask A.
- Add HNO<sub>3</sub> to make a final volume of 100.00 mL.
- Make up the following solutions:

STANDARD SOLUTIONS	TOTAL VOLUME (mL)	VOLUME OF 0.00200 mol L <sup>-1</sup> KSCN (mL)	VOLUME OF 0.200 mol L <sup>-1</sup> Fe(NO <sub>3</sub> ) <sub>3</sub> (mL)	VOLUME OF 0.5 mol L <sup>-1</sup> HNO <sub>3</sub> (mL)
A	100.00	1.00	25.00	74.00
B	100.00	2.00	25.00	73.00
C	100.00	4.00	25.00	71.00
D	100.00	6.00	25.00	69.00
E	100.00	8.00	25.00	67.00
F	100.00	10.00	25.00	65.00



- 6 Rinse the cuvette with distilled water.
- 7  $\frac{3}{4}$  fill the cuvette with distilled water and wipe the clear sides.
- 8 Turn on the colourimeter and turn the light to blue or 470 nm.
- 9 Use the cuvette with distilled water to calibrate the colourimeter. **Note:** Orientate the cuvette correctly in the colourimeter so that the light passes through the clear sides of the cuvette.
- 10 Rinse, a 100 mL beaker with standard solution A – it is easier to pour the solution into the cuvette using a beaker than using a volumetric flask.
- 11 Rinse, then  $\frac{3}{4}$  fill the cuvette with standard solution A and measure the absorbance with the colourimeter.
- 12 Repeat steps 10 and 11 for the other standard solutions (B–F).

## RESULTS

Record all results in a table.

## ANALYSIS OF RESULTS

- 1 Calculate the  $[\text{FeSCN}^{2+}]$  at equilibrium for each standard solution (A–F), assuming all the  $\text{SCN}^-$  has reacted.
- 2 Plot a graph of absorbance versus  $[\text{FeSCN}^{2+}]$  using a spreadsheet program such as Microsoft Excel or Apple Numbers.
- 3 Include a line of best fit.
- 4 Include the equation for the line of best fit.

## PART B

### METHOD

- 1 Label the five 150 mL beakers 1–5.
- 2 Label the 10 mL pipettes with the solution that will be placed in it.
- 3 Use a 10 mL bulb pipette to transfer 10 mL of the  $0.002 \text{ mol L}^{-1} \text{ Fe}(\text{NO}_3)_3$  to beaker 1. **Note:** This solution is a different  $[\text{Fe}(\text{NO}_3)_3]$  to that used in part A.
- 4 Use the graduated 10 mL pipette to transfer 2 mL of the  $0.002 \text{ mol L}^{-1} \text{ KSCN}$  to beaker 1.
- 5 Use another graduated 10 mL pipette to transfer 8 mL of the  $0.5 \text{ mol L}^{-1} \text{ HNO}_3$  to beaker 1.
- 6 Repeat steps 3–5 to make up solutions 2–5 using the volumes given in the table.

STANDARD SOLUTION	TOTAL VOLUME (mL)	VOLUME OF $0.00200 \text{ mol L}^{-1} \text{ KSCN}$ (mL)	VOLUME OF $0.00200 \text{ mol L}^{-1} \text{ Fe}(\text{NO}_3)_3$ (mL)	VOLUME OF $0.5 \text{ mol L}^{-1} \text{ HNO}_3$ (mL)
1	20.00	2.00	10.00	8.00
2	20.00	4.00	10.00	6.00
3	20.00	6.00	10.00	4.00
4	20.00	8.00	10.00	2.00
5	20.00	10.00	10.00	0.00

- 7 Rinse the cuvette with distilled water.
- 8  $\frac{3}{4}$  fill the cuvette with distilled water and wipe the clear sides.
- 9 Turn on the colourimeter and turn the light to blue or 470 nm.
- 10 Use the cuvette with distilled water to calibrate the colourimeter. **Note:** Orientate the cuvette correctly in the colourimeter so that the light passes through the clear sides of the cuvette.
- 11 Rinse a clean 100 mL beaker with the solution in beaker 1 – it is easier to pour the solution into the cuvette using a beaker than using a volumetric flask.
- 12 Rinse, then  $\frac{3}{4}$  fill the cuvette with the solution from beaker 1 and measure the absorbance with the colourimeter.
- 13 Repeat steps 11 and 12 with the solutions from beakers 2–5.



## » RESULTS

Record all results in a table.

### ANALYSIS OF RESULTS

- 1 Calculate the initial concentrations for  $[\text{Fe}^{3+}]$  and  $[\text{SCN}^-]$  for each of solutions in beakers 1–5.
- 2 Use the equation for the line of best fit for the graph in part A to calculate the equilibrium  $[\text{FeSCN}^{2+}]$  for solutions 1–5.
- 3 Use the following equations to determine the equilibrium concentrations for  $\text{Fe}^{3+}$  and  $\text{SCN}^-$ :
  - $[\text{Fe}^{3+}]_{eq} = [\text{Fe}^{3+}]_{na} - [\text{FeSCN}^{2+}]_{eq}$
  - $[\text{SCN}^-]_{eq} = [\text{SCN}^-]_{na} - [\text{FeSCN}^{2+}]_{eq}$
- 4 Calculate the equilibrium constant for the solutions in each of the beakers 1–5.

### DISCUSSION

- 1 Compare the values found for the equilibrium constant for each of the solutions in beakers 1–5.
- 2 Discuss any potential errors and their impact on your results.
- 3 Explain why colourimetry is only an appropriate technique for use with dilute solutions.

### CONCLUSION

Write a conclusion discussing the results of this investigation.



Ethanoic acid and  
methanol in aqueous  
solution

In Investigation 3.2, you determined the equilibrium concentrations of each of the chemical species by using the ICE method, then used these to determine the equilibrium constant. This method involves tabulating the:

- ▶ initial (I) concentrations for each chemical species
- ▶ change (C) in concentration for each chemical species
- ▶ equilibrium (E) concentrations for each chemical species.

To be able to use this method, you need to know the initial concentrations of all species and the equilibrium concentration of at least one species. You use the mole ratios in the balanced chemical equation to determine the changes in concentrations in each of the other chemical species. Then, determine the equilibrium concentrations for each chemical species. The ICE method is illustrated in Worked example 3.4.

## WORKED EXAMPLE 3.4



Numeracy



Critical and creative thinking

Consider the reaction:  $2\text{HI}(\text{g}) \rightleftharpoons \text{H}_2(\text{g}) + \text{I}_2(\text{g})$ . Initially there was  $0.800 \text{ mol L}^{-1}$  present at  $458^\circ\text{C}$ . At equilibrium, there was  $0.0884 \text{ mol L}^{-1}$  of hydrogen present. Calculate the equilibrium constant for this reaction.

ANSWER				LOGIC
$K_{eq} = \frac{[\text{H}_2][\text{I}_2]}{[\text{HI}]^2}$				<ul style="list-style-type: none"> <li>Write the equilibrium expression for the reaction.</li> </ul>
	[HI]	[H <sub>2</sub> ]	[I <sub>2</sub> ]	<ul style="list-style-type: none"> <li>Create a table to show initial concentrations, changes in concentrations and equilibrium concentrations for each species.</li> </ul>
Initial	0.800	0	0	
Change	$-(2 \times 0.0884)$	+0.0884	+0.0884	
Equilibrium	0.623	0.0884	0.0884	
<p>Given change in [H<sub>2</sub>] at equilibrium, since initially there was zero [H<sub>2</sub>] and at equilibrium there was <math>0.0884 \text{ mol L}^{-1}</math>. Change in [I<sub>2</sub>] = change in [H<sub>2</sub>] since 1:1 according to equation. Both increase in concentration. [HI] decreases during reaction since initially only HI was present, but at equilibrium, some reacts to form H<sub>2</sub> and I<sub>2</sub>. According to equation, the [HI] decreases by twice as much as the [H<sub>2</sub>] increases since mole ratio is 2:1.</p>				<ul style="list-style-type: none"> <li>Use moles ratios in the balanced chemical equation to determine the changes in concentration for each species.</li> </ul>
$K_{eq} = \frac{[0.0884] \times [0.0884]}{[0.623]^2} = 0.0201$				<ul style="list-style-type: none"> <li>Use equilibrium concentrations to determine the equilibrium constant.</li> </ul>

### TRY THIS YOURSELF

Consider the reaction  $\text{N}_2\text{O}_4(\text{g}) \rightleftharpoons 2\text{NO}_2(\text{g})$ .  $0.500 \text{ mol}$  of  $\text{N}_2\text{O}_4$  was placed into a  $1 \text{ L}$  flask at  $25^\circ\text{C}$ . When the system reached equilibrium, there was  $0.048 \text{ mol L}^{-1}$  of  $\text{NO}_2$  present in the flask. Calculate the equilibrium constant for this reaction.

## 3.3 Uses of equilibrium constants

As indicated in section 3.2, the magnitude of  $K_{eq}$  can tell us whether there are more products or reactants at equilibrium. Since the products are in the numerator of the equilibrium expression, a large value of  $K_{eq}$  indicates the concentration of products is much greater than the concentration of reactants. Therefore:

- a large value of  $K_{eq}$ , larger than about  $10^3$ , indicates that the equilibrium lies to the right; the concentration of products in the reaction vessel is significantly larger than the concentration of the reactants
- a small value of  $K_{eq}$ , smaller than about  $10^{-3}$ , indicates that the equilibrium lies to the left; the concentration of reactants in the reaction vessel is significantly larger than the concentration of the products
- a value of  $K_{eq}$  close to 1 (about 0.1–10) indicates that there are significant concentrations of both reactants and products present at equilibrium.

There are two main uses for equilibrium constants, as follows:

- to determine if a reaction has reached equilibrium by comparison with  $Q$
- to determine equilibrium concentrations of chemical species.

## Determining if a reaction has reached equilibrium

The equilibrium expression can be used with concentration values for the reactants and products to determine the reaction quotient. The reaction quotient ( $Q$ ) can be calculated and compared to the  $K_{eq}$  for that particular reaction at the specific temperature to determine whether or not the system is at equilibrium. When  $Q = K_{eq}$  then the reaction has reached equilibrium.

- ▶ If  $Q < K_{eq}$ , the forward reaction will be favoured to reach equilibrium.
- ▶ If  $Q > K_{eq}$ , the reverse reaction will be favoured to reach equilibrium.

### WORKED EXAMPLE (3.5)

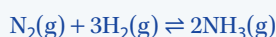


Numeracy



Critical and creative thinking

The Haber process is an important industrial process because it is used to synthesise ammonia from hydrogen and nitrogen according to the following equation:



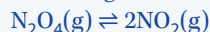
At 427°C, the equilibrium constant for the production of ammonia is 0.26.

The reaction takes place in a 4.00 L flask. Measurements were taken and it was found that there was 1.0 mole of ammonia, 10.0 moles of hydrogen and 15.0 moles of nitrogen present. Is the reaction at equilibrium? If not, in which direction will the reaction proceed?

ANSWER	LOGIC
Volume of flask = 4.00 L $n_{\text{NH}_3} = 1.0 \text{ mol}$ $n_{\text{H}_2} = 10.0 \text{ mol}$ $n_{\text{N}_2} = 15 \text{ mol}$	<ul style="list-style-type: none"> <li>▪ Extract the data from the question.</li> </ul>
$[\text{NH}_3] = \frac{n}{V} = \frac{1.0}{4.00} = 0.25 \text{ mol L}^{-1}$ $[\text{H}_2] = \frac{n}{V} = \frac{10.0}{4.00} = 2.5 \text{ mol L}^{-1}$ $[\text{N}_2] = \frac{n}{V} = \frac{15}{4.00} = 3.25 \text{ mol L}^{-1}$	<ul style="list-style-type: none"> <li>▪ Convert data for each chemical species to concentration in <math>\text{mol L}^{-1}</math>.</li> </ul>
$Q = \frac{[\text{NH}_3]^2}{[\text{N}_2][\text{H}_2]^3}$	<ul style="list-style-type: none"> <li>▪ Write the equation for the reaction quotient from the balanced chemical equation.</li> </ul>
$Q = \frac{(0.25)^2}{3.25 \times (2.5)^3} = 1.2 \times 10^{-3}$	<ul style="list-style-type: none"> <li>▪ Substitute concentration data into the equation for the reaction quotient and solve for <math>Q</math>.</li> </ul>
$1.2 \times 10^{-3} \neq 0.26$ Therefore, $Q \neq K_{eq}$ ; hence, the reaction has not reached equilibrium.	<ul style="list-style-type: none"> <li>▪ Compare <math>Q</math> to <math>K_{eq}</math> to decide if the reaction has reached equilibrium.</li> </ul>
$1.2 \times 10^{-3} < 0.26$ Therefore, since $Q < K_{eq}$ , the reaction will proceed to increase $Q$ ; hence, the numerator ( $\text{NH}_3$ ) must increase so the forward reaction is favoured. The reaction will shift to the right.	<ul style="list-style-type: none"> <li>▪ Using data for <math>Q</math> and <math>K_{eq}</math>, determine which direction is favoured.</li> </ul>

#### TRY THIS YOURSELF

Dinitrogen tetraoxide decomposes to produce nitrogen dioxide according to the equation:



The equilibrium constant for this reaction is 0.48 at 100°C. 0.1 mol of  $\text{N}_2\text{O}_4$  and 0.25 mol of  $\text{NO}_2$  were placed in a 1.00 L flask at 100°C. Is the mixture at equilibrium? If not, in which direction will the reaction proceed?

## Using $K_{eq}$ to calculate an equilibrium concentration

$K_{eq}$  can be used to determine the equilibrium concentration of a chemical species in a reaction if the equilibrium concentration is known for at least one of the other chemical species in the reaction.

### WORKED EXAMPLE 3.6

Phosgene gas ( $\text{COCl}_2$ ) decomposes to produce carbon monoxide gas and chlorine gas. The equilibrium constant for this reaction at 1000 K is 0.40. Initially, only phosgene was present in the reaction vessel. At equilibrium, the concentration of carbon monoxide gas at 1000 K was  $0.24 \text{ mol L}^{-1}$ . Calculate the equilibrium concentration of phosgene.



Numeracy



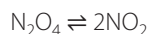
Critical and creative thinking

ANSWER	LOGIC
$\text{COCl}_2(\text{g}) \rightleftharpoons \text{CO}(\text{g}) + \text{Cl}_2(\text{g})$	<ul style="list-style-type: none"> <li>Write a balanced chemical equation for the decomposition of phosgene.</li> </ul>
$K_{eq} = 0.40$ At equilibrium, $[\text{CO}] = 0.24 \text{ mol L}^{-1}$	<ul style="list-style-type: none"> <li>Extract the data from question.</li> </ul>
$K_{eq} = \frac{[\text{CO}][\text{Cl}_2]}{[\text{COCl}_2]}$	<ul style="list-style-type: none"> <li>Write an equation for the equilibrium expression.</li> </ul>
Initially, only $\text{COCl}_2$ was present; using the stoichiometric relationship from the chemical equation therefore, at equilibrium, $[\text{Cl}_2] = [\text{CO}] = 0.24 \text{ mol L}^{-1}$ .	<ul style="list-style-type: none"> <li>Determine <math>[\text{Cl}_2]</math>.</li> </ul>
$[\text{COCl}_2] = \frac{[\text{CO}][\text{Cl}_2]}{K_{eq}}$	<ul style="list-style-type: none"> <li>Rearranging equilibrium expression to make <math>[\text{COCl}_2]</math> the subject, since this is what needs to be determined in this question.</li> </ul>
$[\text{COCl}_2] = \frac{0.24 \times 0.24}{0.40} = 0.14 \text{ mol L}^{-1}$	<ul style="list-style-type: none"> <li>Substitute into the equation and solve for <math>[\text{COCl}_2]</math>.</li> <li>Answer is given to two significant figures since all data in the question is to two significant figures.</li> </ul>

### TRY THIS YOURSELF

An experiment was performed for the decomposition of phosgene to form carbon dioxide and chlorine at  $527^\circ\text{C}$ . The equilibrium constant for this reaction at  $527^\circ\text{C}$  is  $4.63 \times 10^{-3}$ . Initially, only phosgene was present in the reaction vessel. At equilibrium, the concentration of phosgene at  $527^\circ\text{C}$  was  $0.0864 \text{ mol L}^{-1}$ . Calculate the equilibrium concentration of carbon monoxide. (**Hint:** Let  $x$  be the concentration of carbon monoxide at equilibrium.)

- 1 Dinitrogen tetroxide, in chloroform solution, dissociates into nitrogen dioxide, as follows:



The concentrations of the two species at equilibrium at 298 K can be determined from absorption of light (spectrophotometry). Values for three equilibrium mixtures are given below. Calculate the equilibrium constant for the reaction.

	MIXTURE A	MIXTURE B	MIXTURE C
$[\text{N}_2\text{O}_4] (\text{mol L}^{-1})$	0.129	0.324	0.778
$[\text{NO}_2] (\text{mol L}^{-1})$	0.00117	0.00185	0.00284

- Calculate the equilibrium constant for each of the mixtures.
- Discuss the reliability of the data gathered in this investigation.

### CHECK YOUR UNDERSTANDING

3.2

3.3



Numeracy



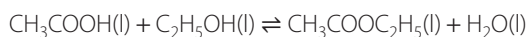
Critical and creative thinking





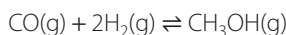


- 2 To measure the equilibrium constant for the reaction:



1.00 mol L<sup>-1</sup> of pure acetic acid and 0.18 mol L<sup>-1</sup> of pure ethanol were mixed. At equilibrium, there was 0.171 mol L<sup>-1</sup> of ethyl acetate. Calculate the equilibrium constant.

- 3 Methanol can be made by the reaction:

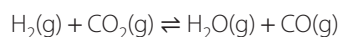


At 100°C, an equilibrium mixture was found to have the following concentrations:

$$[\text{CO}] = 3.76 \times 10^{-3} \text{ mol L}^{-1}; [\text{H}_2] = 4.30 \times 10^{-3} \text{ mol L}^{-1}; [\text{CH}_3\text{OH}] = 4.17 \times 10^{-8} \text{ mol L}^{-1}$$

Calculate the equilibrium constant for the reaction. What would be the effect on the value for  $K$  of using a catalyst for this reaction?

- 4 One mole of hydrogen and one mole of carbon dioxide were placed in a closed container of 1.00 L volume and brought to equilibrium at 1260 K, the reaction being:

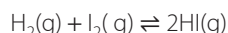


The equilibrium mixture was rapidly cooled – so rapidly that the equilibrium was unable to adjust itself as the temperature changed (because the rates of both the forward and reverse reactions became very small). The system was therefore ‘frozen’ into the state corresponding to equilibrium at 1260 K. The amount of CO<sub>2</sub> present was measured; it corresponded to a concentration of 0.44 mol L<sup>-1</sup> at 1260 K. Calculate the equilibrium constant for this reaction at 1260 K.

- 5 For the reactions listed below, the values of the equilibrium constants at specified temperatures are given in brackets after the equations. For each reaction at the specified temperature, does the equilibrium lie well to the left, well to the right or about in the middle?

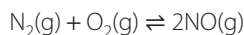
- a  $\text{Ag}^+(\text{aq}) + 2\text{NH}_3(\text{aq}) \rightleftharpoons \text{Ag}(\text{NH}_3)_2^+(\text{aq})$  ( $K_{\text{eq}} = 1.6 \times 10^7$  at 298 K)  
b  $\text{N}_2(\text{g}) + 3\text{H}_2(\text{g}) \rightleftharpoons 2\text{NH}_3(\text{g})$  ( $K_{\text{eq}} = 1.6 \times 10^{-3}$  at 1000 K)  
c  $\text{Br}_2(\text{aq}) + \text{Br}^-(\text{aq}) \rightleftharpoons \text{Br}_3^-(\text{aq})$  ( $K_{\text{eq}} = 18$  at 298 K)  
d  $\text{I}_2(\text{g}) \rightleftharpoons 2\text{I}(\text{g})$  ( $K_{\text{eq}} = 4 \times 10^{-5}$  at 1000 K)  
e  $\text{N}_2\text{O}_4(\text{g}) \rightleftharpoons 2\text{NO}_2(\text{g})$  ( $K_{\text{eq}} = 0.48$  at 373 K)  
f  $\text{Zn}^{2+}(\text{aq}) + 4\text{CN}^-(\text{aq}) \rightleftharpoons \text{Zn}(\text{CN})_4^{2-}(\text{aq})$  ( $K_{\text{eq}} = 10^{19}$  at 298 K)  
g  $\text{N}_2(\text{g}) + \text{O}_2(\text{g}) \rightleftharpoons 2\text{NO}(\text{g})$  ( $K_{\text{eq}} = 10^{-3}$  at 2000 K)  
h  $\text{CO}(\text{g}) + \text{Cl}_2(\text{g}) \rightleftharpoons \text{COCl}_2(\text{g})$  ( $K_{\text{eq}} = 4 \times 10^5$  at 400 K)

- 6 At 500 K, the equilibrium constant for the reaction below is 159.

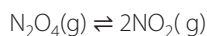


Two mixtures are prepared with the concentrations given below. For each mixture, is the reaction at equilibrium? If not, in which direction will the reaction proceed?

- a  $[\text{H}_2] = 0.14 \text{ mol L}^{-1}$ ,  $[\text{I}_2] = 0.078 \text{ mol L}^{-1}$ ,  $[\text{HI}] = 1.74 \text{ mol L}^{-1}$   
b  $[\text{H}_2] = 0.32 \text{ mol L}^{-1}$ ,  $[\text{I}_2] = 0.24 \text{ mol L}^{-1}$ ,  $[\text{HI}] = 0.83 \text{ mol L}^{-1}$
- 7 The equilibrium constant for the following reaction at 1500 K is  $1.0 \times 10^{-5}$ .



- a A particular mixture at 1500 K was 0.050 mol L<sup>-1</sup> in N<sub>2</sub>, 0.025 mol L<sup>-1</sup> in O<sub>2</sub> and 0.0030 mol L<sup>-1</sup> in NO. Is this mixture at equilibrium? If not, in which direction will the reaction go? Give your reasoning.  
b Another mixture at the same temperature was 0.35 mol L<sup>-1</sup> in N<sub>2</sub>, 0.60 mol L<sup>-1</sup> in O<sub>2</sub> and 0.0010 mol L<sup>-1</sup> in NO. Is this mixture at equilibrium? If not, in which direction will the reaction go?
- 8 At 100°C the equilibrium constant for the following reaction is 0.48.



- a A mixture of N<sub>2</sub>O<sub>4</sub> and NO<sub>2</sub> is brought to equilibrium. The equilibrium concentration of N<sub>2</sub>O<sub>4</sub> is 0.15 mol L<sup>-1</sup>. Calculate the concentration of NO<sub>2</sub>.  
b Another equilibrium mixture at the same temperature has an NO<sub>2</sub> concentration of 0.25 mol L<sup>-1</sup>. Calculate the equilibrium concentration of N<sub>2</sub>O<sub>4</sub>.



- 9 Iodine, in aqueous solution, reacts with iodide to form the triiodide ion:



The equilibrium constant for this reaction is 723 at 25°C.

- a Calculate the ratio  $\frac{[\text{I}_3^-]}{[\text{I}_2]}$  in a solution at 298 K in which the equilibrium concentration of iodide is  $7.00 \times 10^{-3} \text{ mol L}^{-1}$ .
- b What equilibrium concentration of iodide is needed to convert 99 per cent of the iodine initially added to a solution to triiodide?
- 10 At 250°C, the equilibrium constant for the following reaction is 0.042.



- a A sample of  $\text{PCl}_5$  was placed in a vessel and heated to 250°C. At equilibrium, the concentration of chlorine was  $0.084 \text{ mol L}^{-1}$ . Calculate the equilibrium concentrations of  $\text{PCl}_3$  and  $\text{PCl}_5$ .
- b Another sample of  $\text{PCl}_5$  was similarly heated to 250°C. At equilibrium, the concentration of  $\text{PCl}_5$  was  $0.095 \text{ mol L}^{-1}$ . Calculate the equilibrium concentration of  $\text{PCl}_3$ .

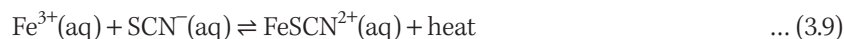
## 3.4

# Effect of temperature on the equilibrium constant

The equilibrium constant provides information about the ratio of products to reactants for a specific reaction at equilibrium at a specific temperature. If the concentration of one of the chemical species in the reaction changes, according to Le Chatelier's principle, the system will adjust to favour the reaction that minimises the change to the reaction. This leads to an adjustment of the concentrations of reactants and products so that the ratio of products to reactants is again the same as the equilibrium constant. This was evident in Investigation 3.2 where the concentrations of the chemical species for the formation of  $\text{FeSCN}^{2+}$  were different in beakers 1–5, yet the equilibrium constant was the same in each instance.

In chapter 2, you saw the qualitative effect of temperature on an equilibrium system both in terms of particle theory and Le Chatelier's principle. You learnt about the effects of heating or cooling a system and whether the forward or reverse reaction was favoured. Here, the explanation is taken one step further and look at the effect on the equilibrium constant.

The reaction to form  $\text{FeSCN}^{2+}$  is exothermic; hence, it has a negative enthalpy. It could be written as:



Therefore, if the temperature of the system is increased, then according to Le Chatelier's principle, the system will adjust to minimise the change. Hence, in this case, the reverse reaction is favoured since it absorbs (uses up) the heat that has been added to the system. In doing this, the  $[\text{Fe}^{3+}]$  and  $[\text{SCN}^-]$  increase and the  $[\text{FeSCN}^{2+}]$  decreases. This, in turn, changes the ratio of the concentration of products to the concentration of the reactants, and therefore, changes the equilibrium constant.

$$K = \frac{[\text{products}]}{[\text{reactants}]} = \frac{\text{smaller number (decreased concentration)}}{\text{bigger number (increased concentrations)}} = \text{smaller value for } K$$

So, the equilibrium constant decreases as the temperature at which the reaction occurs increases for an exothermic reaction. The opposite is the case for endothermic reactions.

This is why the temperature is always specified when an equilibrium constant is given.

Table 3.1 (page 72) shows how the equilibrium constant changes as the temperature increases for several different chemical reactions.

Go to section 2.4 on page 39 to revise the effect of temperature on equilibrium in terms of particle theory and Le Chatelier's principle.



Calculating equilibrium values

**TABLE 3.1** Temperature dependence of some equilibrium constants\*

a $N_2O_4(g) \rightleftharpoons 2NO_2(g)$		b $N_2(g) + 3H_2(g) \rightleftharpoons 2NH_3(g)$	
Temperature (K)	K	Temperature (K)	K
273	$5.7 \times 10^{-4}$	298	$4.0 \times 10^8$
298	$4.7 \times 10^{-3}$	500	60.0
373	0.48	700	0.26
500	41.4	900	$5.4 \times 10^{-3}$
c		d	
Temperature (K)	K	Temperature (K)	K
600	450.0	273	1360
700	30.0	298	723
850	1.6	330	372
1000	0.21	370	190

\*Equilibrium constants are as defined in equation 3.3.

## 3.5 Applications of $K_{eq}$ for different types of chemical reactions

As you will learn in chapter 16, industrial processes need to consider equilibrium constants when determining the conditions required to maximise the yield of the product under the most economical conditions. Equilibrium constants also give useful information for other types of chemical systems.

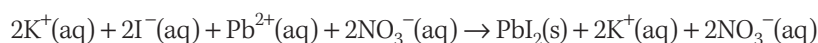
### Introduction to solubility equilibria

Some basic ideas on solubility equilibria are introduced here. This will be done in much greater detail in chapter 4 ('Solubility equilibria').

In Module 3 of the Year 11 course, you investigated some precipitation reactions. An example would be the reaction between potassium iodide and lead nitrate:



Each of the aqueous substances can be written as ions, since in solution the ions are free to move. However, the precipitate remains as a solid and does not separate into its ions. Hence, equation 3.10 can be rewritten as:



The  $K^+(aq)$  and  $NO_3^-(aq)$  have not taken part in the chemical reaction. They started as ions and finished up as ions. They are called spectator ions. The reaction can now be simplified to include only the species that took part in the reaction:



Although  $PbI_2$  is a precipitate, it is in dynamic equilibrium with its ions in a saturated solution.

The convention is to write the solid on the left side of the equation and its ions on the right side of the equation. Since the solid is in dynamic equilibrium with its ions, the equilibrium arrows ( $\rightleftharpoons$ ) are used; hence, equation 3.11 should be rewritten as:



The equilibrium constant for an equation written in this way is called the **solubility product**,  $K_{sp}$ . The equilibrium expression for this reaction is:

$$K_{sp} = [\text{Pb}^{2+}] \times [\text{I}^-]^2$$

Since this is a heterogeneous system, the solid is not included in the equilibrium expression.

The smaller the solubility product for a precipitate, the lower its solubility.

Earlier in the chapter, you learnt that the equilibrium constant could only be used if the concentrations were measured at equilibrium. If the concentrations of the chemical species were measured when the system was not at equilibrium, then the expression represented the reaction quotient,  $Q$ .

When considering solubility equilibria, the term 'solubility product' is only used when the concentrations of the chemical species are measured at equilibrium. If the concentrations of the chemical species are measured when the system is not at equilibrium, then the expression represents the **ionic product**.

- If the ionic product =  $K_{sp}$ , then the system is at equilibrium.
- If the ionic product <  $K_{sp}$ , the forward reaction would be favoured and the solid would dissolve for the system to reach equilibrium.
- If the ionic product >  $K_{sp}$ , the reverse reaction would be favoured and more precipitate would form for the system to reach equilibrium.

## Introduction to dissociation of acids and bases

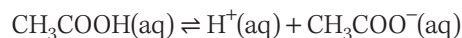
Some basic ideas on the dissociation of acids and bases are introduced here. This will be done in much greater detail in Module 6 ('Acid/base reactions'). The quantitative treatment of the dissociation of acids and bases will be covered in chapter 6 ('Using Brønsted–Lowry theory').

### Equilibrium constants for acids

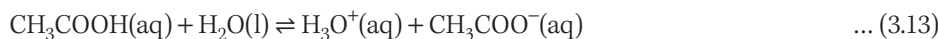
In some acids, all of the molecules ionise in water to form their ions. However, in other acids only some of the molecules ionise. Here, you are looking at acids in which only some of the molecules ionise when placed in water. These acids are called **weak acids**.

For acids that only partially ionise in water, some of their molecules break apart to form hydrogen ions and the anion of the acid. Other molecules of the acid remain as molecules and do not ionise. Therefore, this is an example of an equilibrium reaction. For example, some of the molecules of acetic acid ( $\text{CH}_3\text{COOH}$ ) ionise to form  $\text{H}^+$  and  $\text{CH}_3\text{COO}^-$ . This is illustrated in Figure 3.2.

In simplified form, the chemical equation for acetic acid, which only partially ionises in water, can be written as:



However, since the ionisation process occurs in water, it is more correctly written by including the water and hydronium ion ( $\text{H}_3\text{O}^+$ ), as:



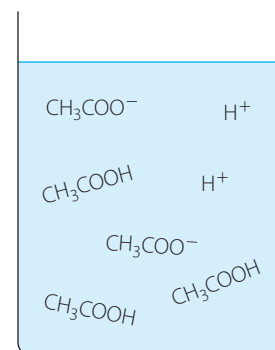
Since this is an equilibrium reaction, an equilibrium expression can be written:

$$K_{eq} = \frac{[\text{H}_3\text{O}^+][\text{CH}_3\text{COO}^-]}{[\text{CH}_3\text{COOH}][\text{H}_2\text{O}]}$$

This can be rewritten as:

$$K_{eq} = \frac{[\text{H}_3\text{O}^+][\text{CH}_3\text{COO}^-]}{[\text{CH}_3\text{COOH}]}$$

A detailed explanation of weak acids can be found in section 6.3.



**FIGURE 3.2** In simplified form, acetic acid only partially ionises to form hydrogen ions and acetate ions.

Since the concentration of water is approximately constant in a dilute solution, the equilibrium constant for the ionisation of an acid is called the **acid dissociation constant** ( $K_a$ ).

$$K_a = K_{eq} \times [\text{H}_2\text{O}]$$

The equilibrium expression for  $K_a$  for equation 3.13 is:

$$K_a = \frac{[\text{H}_3\text{O}^+][\text{CH}_3\text{COO}^-]}{[\text{CH}_3\text{COOH}]} \quad \dots (3.14)$$

The general equation for a weak acid is:



Therefore, the general expression for the equilibrium constant for a weak acid is:

$$K_a = \frac{[\text{H}_3\text{O}^+][\text{A}^-]}{[\text{HA}]} \quad \dots (3.16)$$

The size of the constant provides information about the degree of ionisation that occurs. The larger the  $K_a$ , the larger the value of the numerator in equation 3.16; hence, the greater the concentration of ions compared to the concentration of molecules of the acid and therefore, the greater the degree of ionisation. pH meters can accurately measure the concentration of the hydronium ions; hence, for a known concentration of acid, the acid dissociation constant can be determined.

## Dissociation constants for bases

A **weak base** is a base where only some of the molecules of the base react with water to produce ions. This **dissociation reaction** is illustrated in Figure 3.3. Ammonia is an example of a weak base.

The equation for the reaction between ammonia and water is given:



Since this is an equilibrium reaction, an equilibrium expression can be written as:

$$K_{eq} = \frac{[\text{NH}_4^+][\text{OH}^-]}{[\text{NH}_3][\text{H}_2\text{O}]}$$

This can be rewritten as:

$$K_{eq} \times [\text{H}_2\text{O}] = \frac{[\text{NH}_4^+][\text{OH}^-]}{[\text{NH}_3]}$$

Since the concentration of water is approximately constant in a dilute solution, the equilibrium constant is denoted as  $K_b$ :

$$K_b = K_{eq} \times [\text{H}_2\text{O}]$$

The equilibrium expression for  $K_b$  for equation 3.17 is:

$$K_b = \frac{[\text{NH}_4^+][\text{OH}^-]}{[\text{NH}_3]} \quad \dots (3.18)$$

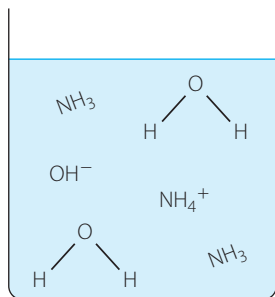
The general equation for a base reacting with water is:



Therefore, the general expression for the **base dissociation constant** for a weak base is:

$$K_b = \frac{[\text{BH}^+][\text{OH}^-]}{[\text{B}]} \quad \dots (3.20)$$

A detailed explanation of weak bases can be found in section 6.3.



**FIGURE 3.3** Some molecules of ammonia react with water to produce ammonium ions and hydroxide ions. This is an example of a dissociation reaction.

## Expressing equilibrium constants for gaseous systems in terms of pressure

All of the examples presented in this chapter have involved expressing equilibrium constants using concentration values for each chemical species in a specific chemical reaction. Even the examples from gaseous systems have expressed the data in this way. However, equilibrium constants for gaseous systems can also be expressed in terms of pressure. The symbol used for this is  $K_p$ .

Pressure can be expressed using a variety of units, including atmospheres (atm), kilopascals (kPa) or millimetres of mercury (mmHg). The pressure for each chemical species in a gaseous state can be expressed in any unit of pressure. However, the units used must be consistent for all gaseous species in a particular chemical reaction.

There are two important terms that you need to understand before looking at equilibrium systems:

- ▶ mole fraction
- ▶ partial pressure.

The **mole fraction** is determined for each species when there is a mixture of gases in the same container. For example, there is a mixture of 1 mole of chlorine gas ( $\text{Cl}_2$ ) and 5 moles of phosphorus trichloride ( $\text{PCl}_3$ ) in the same container. Hence, there is a total of 6 moles of gas in the container.

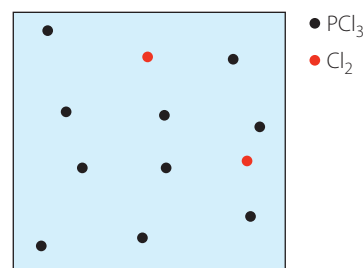
$$\text{Mole fraction of } \text{Cl}_2 = \frac{\text{Number of moles of } \text{Cl}_2}{\text{Total number of moles of gas present}} = \frac{1}{6}$$

$$\text{Mole fraction of } \text{PCl}_3 = \frac{\text{Number of moles of } \text{PCl}_3}{\text{Total number of moles of gas present}} = \frac{5}{6}$$

- The general equation for the mole fraction is:

$$\text{Mole fraction of gas A} = \frac{\text{Number of moles of gas A}}{\text{Total number of moles of gas present}}$$

Gases create pressure when they collide with the walls of a container. Hence, if there is a mixture of gases in the container, then the pressure is due to the collisions of all particles of all gases with the walls of the container. We'll use the example above with the chlorine and phosphorus trichloride and a total pressure in the container of 120 atmospheres (atm). The **partial pressure** is the proportion of the pressure that is due to the collisions for a particular gas present. In Figure 3.4, the mole ratio of chlorine molecules is  $\frac{1}{6}$  and the mole ratio of phosphorus trichloride is  $\frac{5}{6}$ . You can see in the diagram that the phosphorus trichloride molecules are five times more likely to collide with the sides of the container than the chlorine molecules.



**FIGURE 3.4** Container with a gaseous mixture of  $\text{Cl}_2$  and  $\text{PCl}_3$  molecules

$$\text{Partial pressure of } \text{Cl}_2 = \text{Mole fraction of } \text{Cl}_2 \times \text{Total pressure of the system} = \frac{1}{6} \times 120 = 20 \text{ atm}$$

$$\text{Partial pressure of } \text{PCl}_3 = \text{Mole fraction of } \text{PCl}_3 \times \text{Total pressure of the system} = \frac{5}{6} \times 120 = 100 \text{ atm}$$

- The general equation for the partial pressure of a gas in a system containing a mixture of gases is:

$$\text{Partial pressure of gas A} = \text{Mole fraction of gas A} \times \text{Total pressure of the system}$$



To write the expression for the equilibrium constant in terms of pressures, you include the partial pressures for each species, instead of their concentrations. The generalised equation for a gaseous reaction is given in equation 3.21:



The expression for the equilibrium constant in terms of pressure ( $K_p$ ) is:

$$K_p = \frac{P_A^a \times P_B^b}{P_C^c \times P_D^d}$$

Do not use brackets when writing the expression for  $K_p$  since (square) brackets indicate concentrations. You need to clearly specify that you are using pressures and not concentrations. Only gaseous species are included in the expression for  $K_p$ . The value for the equilibrium constant in terms of pressure is different to the equilibrium constant for a reaction in terms of concentration:

$$K_p \neq K_c$$

Therefore, you need to clearly specify which equilibrium constant you are using. There is a relationship between the two equilibrium constants, using the ideal gas equation, but that is beyond the scope of this course.



Check your understanding

### WORKED EXAMPLE (3.7)



Numeracy

The following reaction reached equilibrium with the total pressure of the system being 5 atm. At equilibrium, there was 1.45 moles of  $\text{Cl}_2\text{O}_5$ , 0.729 moles of  $\text{Cl}_2$  and 0.822 moles of  $\text{O}_2$  present.



Critical and creative thinking

Calculate  $K_p$  for this reaction.

ANSWER	LOGIC
<p>Mole fraction for <math>\text{Cl}_2\text{O}_5 = \frac{n_{\text{Cl}_2\text{O}_5}}{\text{total moles of gas}} = \frac{1.45}{3.00} = 0.483</math></p> <p>Mole fraction for <math>\text{Cl}_2 = \frac{n_{\text{Cl}_2}}{\text{total moles of gas}} = \frac{0.729}{3.00} = 0.243</math></p> <p>Mole fraction for <math>\text{O}_2 = \frac{n_{\text{O}_2}}{\text{total moles of gas}} = \frac{0.822}{3.00} = 0.274</math></p>	<ul style="list-style-type: none"> <li>Convert the moles to mole fractions for each gaseous species.</li> </ul>
<p>Partial pressure for <math>\text{Cl}_2\text{O}_5 = \text{Mole fraction for } \text{Cl}_2\text{O}_5 \times \text{total pressure}</math>  <math>= 0.483 \times 5</math>  <math>= 2.42 \text{ atm}</math></p> <p>Partial pressure for <math>\text{Cl}_2 = \text{Mole fraction for } \text{Cl}_2 \times \text{total pressure}</math>  <math>= 0.243 \times 5</math>  <math>= 1.22 \text{ atm}</math></p> <p>Partial pressure for <math>\text{O}_2 = \text{Mole fraction for } \text{O}_2 \times \text{total pressure}</math>  <math>= 0.274 \times 5</math>  <math>= 1.37 \text{ atm}</math></p>	<ul style="list-style-type: none"> <li>Convert mole fractions to partial pressures for each gaseous species.</li> </ul>

ANSWER	LOGIC
$K_p = \frac{P_{Cl_2}^2 \times P_{O_2}^5}{P_{Cl_2O_3}^2}$	<ul style="list-style-type: none"> <li>Write the equilibrium expression for <math>K_p</math>, including only gaseous species in the expression.</li> </ul>
$K_p = \frac{1.22^2 \times 137^5}{2.42^2}$	<ul style="list-style-type: none"> <li>Substitute partial pressures into the equilibrium expression.</li> </ul>
$K_p = 1.23$	<ul style="list-style-type: none"> <li>Calculate answer.</li> </ul>

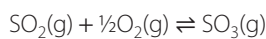
### TRY THIS YOURSELF

Consider the reaction  $2H_2(g) + O_2(g) \rightleftharpoons 2H_2O(l)$ . At equilibrium, the partial pressure of hydrogen was 0.705 atm and the partial pressure of oxygen was 2.21 atm. Calculate the  $K_p$  for this reaction.

- 1 Explain, using Le Chatelier's principle, whether the equilibrium constant for each of the following reactions increases or decreases as temperature rises:

- a**  $CO(g) + 2H_2(g) \rightleftharpoons CH_3OH(g)$   $\Delta H$  is negative  
**b**  $CO_2(g) + H_2(g) \rightleftharpoons CO(g) + H_2O(g)$   $\Delta H$  is positive  
**c**  $CO(g) + Cl_2(g) \rightleftharpoons COCl_2(g)$  exothermic  
**d**  $N_2(g) + O_2(g) \rightleftharpoons 2NO(g)$  endothermic

- 2 Consider the reaction:



The equilibrium constant for this reaction is  $3.5 \times 10^4$  at 600 K, while it is  $2.2 \times 10^3$  at 700 K. Justify whether the synthesis of sulfur trioxide is endothermic or exothermic.

- 3 Write the expression for the solubility product for each of the following saturated solutions.

- a** Silver chloride  
**b** Aluminium hydroxide

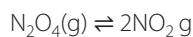
- 4 Write the expression for the acid dissociation constant for the following weak acids.

- a** Hypochlorous acid (HOCl)  
**b** Hydrocyanic acid (HCN)

- 5 Write the expression for the base dissociation constant for the following weak bases.

- a** Methylamine ( $CH_3NH_2$ )  
**b** Phenylamine ( $C_6H_5NH_2$ )

- 6 The equilibrium partial pressures are 0.723 atm for  $N_2O_4$  and 0.693 atm for  $NO_2$  at 45°C. Calculate the equilibrium constant in terms of pressure for the reaction:



### CHECK YOUR UNDERSTANDING

3.4 3.5



Numeracy



Critical and creative thinking

# 3 CHAPTER SUMMARY

## IMPORTANT NEW TERMS

After studying this chapter you should know the meaning of the following terms:

acid dissociation constant (p. 74)

base dissociation constant (p. 74)

dissociation reaction (p. 74)

equilibrium constant ( $K$  or  $K_{eq}$ ) (p. 54)

equilibrium expression (p. 54)

ionic product (p. 73)

mole fraction (p. 75)

partial pressure (p. 75)

reaction quotient (p. 57)

solubility product (p. 73)

weak acid (p. 73)

weak base (p. 74)

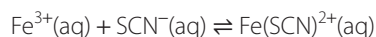
## AFTER STUDYING THIS CHAPTER YOU SHOULD KNOW:

- the definitions for all terms in the important new terms list
- the species to include in the reaction quotient
- the difference between the equilibrium constant and reaction quotient
- the difference between solubility product and ionic product
- why temperature changes the value of an equilibrium constant.

## YOU SHOULD BE ABLE TO:

- write equilibrium expressions for a variety of heterogeneous ( $K_{eq}$ ) and homogeneous reactions, including  $K_{sp}$ ,  $K_a$  and  $K_b$
- interpret equilibrium constants to determine the relative amounts of reactants and products
- compare the reaction quotient with the equilibrium constant to determine whether a reaction is at equilibrium
- calculate the equilibrium constant for a reaction given the equilibrium concentration for all chemical species
- calculate the equilibrium constant for a reaction given the initial concentrations for all chemical species and the equilibrium concentration for one of the chemical species
- use the equilibrium constant to calculate the concentration of a species at equilibrium
- explain the effect of temperature on the equilibrium expression for both endothermic and exothermic reactions
- interpret absorbance versus concentration graphs
- interpret temperature changes on both the equilibrium position and the rate of a chemical reaction.

- 1** Explain why solids and liquids are not included in the equilibrium expression for a heterogeneous system.
- 2** Describe the relative concentrations of reactants and products for a reaction with an equilibrium constant of  $5.0 \times 10^{-17}$ .
- 3** Write the equilibrium expression for the dissociation of acetic acid in water.
- 4** Ammonia may be produced from its elements according to the equation:
- $$\text{N}_2(\text{g}) + 3\text{H}_2(\text{g}) \rightleftharpoons 2\text{NH}_3(\text{g}) \quad \Delta H = -92 \text{ kJ/mol}$$
- a** Write an expression for the equilibrium constant ( $K$ ) for this reaction.
- b** If the equilibrium constant for this reaction at  $500^\circ\text{C}$  is  $1.1 \times 10^{-7}$ , what is the equilibrium constant for the reverse reaction?
- 5** Explain what information the  $K$  values for the following equilibria give about the reactions involved.
- a**  $\text{HNO}_3(\text{aq}) + \text{H}_2\text{O}(\text{l}) \rightleftharpoons \text{H}_3\text{O}^+(\text{aq}) + \text{NO}_3^-(\text{aq})$   
 $K_{\text{eq}} = 19.9$  at  $25^\circ\text{C}$
- b**  $\text{PbCl}_2(\text{s}) \rightleftharpoons \text{Pb}^{2+}(\text{aq}) + 2\text{Cl}^-(\text{aq})$   
 $K_{\text{eq}} = 1.7 \times 10^{-5}$  at  $25^\circ\text{C}$
- 6** At  $800 \text{ K}$ , the equilibrium constant for the reaction:
- $$\text{COCl}_2(\text{g}) \rightleftharpoons \text{CO}(\text{g}) + \text{Cl}_2(\text{g})$$
- is  $5.0 \times 10^{-3}$ . At this temperature, what is the value of the equilibrium constant for the following reaction.
- $$2\text{CO}(\text{g}) + 2\text{Cl}_2(\text{g}) \rightleftharpoons 2\text{COCl}_2(\text{g})$$
- 7** Iron(III) ions react with colourless thiocyanate ( $\text{SCN}^-$ ) to form an intensely red-coloured complex in an equilibrium reaction:



By knowing the starting concentrations of  $\text{Fe}^{3+}$  and  $\text{SCN}^-$  and measuring the concentration of  $\text{Fe}(\text{SCN})^{2+}$  by colourimetry, it is possible to determine the concentrations of all species at equilibrium. Use the equilibrium concentrations (all in  $\text{mol L}^{-1}$ ) in the table below to calculate the equilibrium constant for this reaction.

$[\text{Fe}^{3+}]$	0.200	0.200	0.100	0.100
$[\text{Fe}(\text{SCN})^{2+}]$	0.0094	0.0190	0.0087	0.0047
$[\text{SCN}^-]$	0.00060	0.0012	0.0011	0.00060

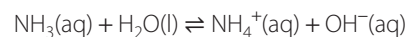


Numeracy



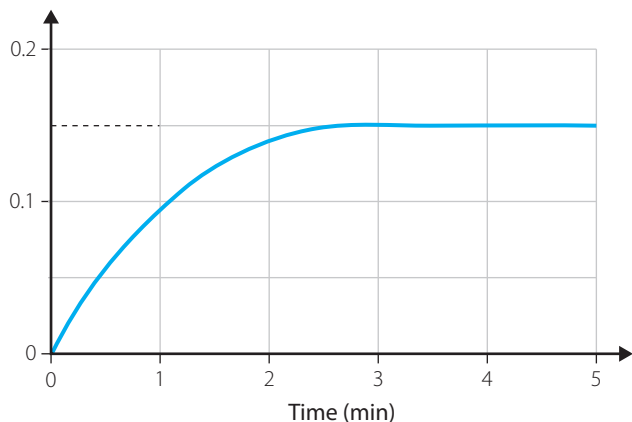
Critical and creative thinking

- 8** Phosgene gas ( $\text{COCl}_2$ ) decomposes to carbon monoxide and chlorine at elevated temperatures.  $0.050$  mole of phosgene was placed in a  $1.0 \text{ L}$  flask and heated to  $400^\circ\text{C}$ . At equilibrium, it was found that the concentration of chlorine was  $0.0060 \text{ mol L}^{-1}$ . Calculate the equilibrium constant.
- 9** For the reaction:
- $$\text{Br}_2(\text{aq}) + \text{Br}^-(\text{aq}) \rightleftharpoons \text{Br}_3^-(\text{aq})$$
- the equilibrium constant at  $298 \text{ K}$  is  $18$ . What is the concentration of  $\text{Br}_2$  in a solution in which the equilibrium concentrations of bromide and tribromide are  $0.085$  and  $0.050 \text{ mol L}^{-1}$  respectively?
- 10** At  $1000 \text{ K}$  the equilibrium constant is  $246$  for the reaction:
- $$2\text{SO}_2(\text{g}) + \text{O}_2(\text{g}) \rightleftharpoons 2\text{SO}_3(\text{g})$$
- At equilibrium, the concentrations of  $\text{SO}_2$  and  $\text{O}_2$  are  $0.600 \text{ mol L}^{-1}$  and  $1.00 \text{ mol L}^{-1}$  respectively, what is the equilibrium concentration of  $\text{SO}_3$ ?
- 11** Nitrogen dioxide ( $\text{NO}_2$ ) a brown gas often present in photochemical smog, decomposes when heated according to the equilibrium:
- $$2\text{NO}_2(\text{g}) \rightleftharpoons 2\text{NO}(\text{g}) + \text{O}_2(\text{g}), \text{ for which } K = 9.0 \text{ at } 910^\circ\text{C}$$
- An analysis of a mixture of  $\text{NO}_2$ ,  $\text{NO}$  and  $\text{O}_2$  at  $910^\circ\text{C}$  shows the concentrations of these species to be  $2.0 \text{ mol L}^{-1}$ ,  $1.0 \text{ mol L}^{-1}$  and  $2.0 \text{ mol L}^{-1}$  respectively.
- a** Is this an equilibrium mixture?
- b** If the mixture is not an equilibrium mixture, which reaction – forward or reverse – will be favoured as the system moves to equilibrium?
- 12** A  $0.0500 \text{ mol L}^{-1}$  solution of ammonia contained a hydroxide concentration of  $9.49 \times 10^{-4} \text{ mol L}^{-1}$  at equilibrium.
- Calculate the base dissociation constant ( $K_b$ ) for the reaction:



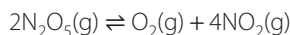
- 13** At room temperature, gaseous dinitrogen pentoxide decomposes to nitrogen dioxide and oxygen. In a particular experiment, 0.10 mol of dinitrogen pentoxide was placed in a 1.00 L flask and the concentration of nitrogen dioxide was measured as a function of time. The results are represented in Figure 3.5.

Calculate the equilibrium constant for the reaction:



**FIGURE 3.5** Quantitative equilibria

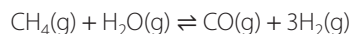
- 14** Calculate  $K_p$  for the following reaction:



At temperature ( $T$ ), the partial pressures for each of the gases at equilibrium were:

- $\text{N}_2\text{O}_5 = 3.00$  atm
- $\text{O}_2 = 0.142$  atm
- $\text{NO}_2 = 2.50$  atm.

- 15** A reaction commonly used industrially as a source of hydrogen is:



The equilibrium constant is 0.26 at 1200 K.

- a** Write the equilibrium expression for this reaction.
- b** In a particular reaction mixture, the concentrations were:  
 $[\text{CH}_4] = 0.045$  mol L<sup>-1</sup>,  $[\text{H}_2\text{O}] = 0.24$  mol L<sup>-1</sup>  
 $[\text{CO}] = 0.060$  mol L<sup>-1</sup>,  $[\text{H}_2] = 0.50$  mol L<sup>-1</sup>
- Is this mixture at equilibrium? Explain how you made your decision.
- c** Depending on your answer to part **b**, answer one of the questions below.
- If the mixture in part **b** is not at equilibrium, in which direction will the reaction go as the mixture approaches equilibrium – to the right or to the left? Explain why.
  - If the mixture in part **b** is at equilibrium, in which direction will the reaction go if the mixture is suddenly compressed into half the original volume? Explain why.
- d** At 1400 K, the value of the equilibrium constant is greater than at 1200 K. Is the reaction exothermic or endothermic? Explain how you made your decision.

## 4

## Solution equilibria

## INQUIRY QUESTION

How does solubility relate to chemical equilibrium?

## Students:

describe and analyse the processes involved in the dissolution of ionic compounds in water

investigate the use of solubility equilibria by Aboriginal and Torres Strait Islander Peoples when removing toxicity from foods, for example: [ATSIHC](#)

– toxins in cycad fruit

conduct an investigation to determine solubility rules, and predict and analyse the composition of substances when two ionic solutions are mixed, for example:

– potassium chloride and silver nitrate

– potassium iodide and lead nitrate

– sodium sulfate and barium nitrate [ACSCH06](#))

derive equilibrium expressions for saturated solutions in terms of  $K_p$  and calculate the solubility of an ionic substance from its  $K_p$  value [ICT N](#)

predict the formation of a precipitate given the standard reference values for  $K_p$ .

Chemistry Stage 6 Syllabus © NSW Educational Standards Authority for and on behalf of the Crown in right of the State of New South Wales, 2017







**FIGURE 4.1** Dissolving coffee crystals in hot water helps us get our day started.

Solubility is an important concept that is used in many parts of our daily life. Stain removal involves identifying an appropriate solvent to remove the stain. Painters need to have an understanding of the role of solvents when cleaning their brushes. Some drinks involve dissolving a solid in water (for example, making a cup of coffee). When looking at disposal of chemicals in the school science laboratories, you are given instructions for different chemicals, dependent on both their solubility and their toxicity. Copper salts, although soluble in water, are not disposed of down the drain. Instead, you're given a waste bottle. This

is because chemicals disposed of down the drain are eventually released into our waterways and could enter the food chain or our water supplies. The World Health Organization has set the level of  $2\text{mgL}^{-1}$  as the safe level of copper ions in drinking water. Humans have known about the importance of solubility for a long time. Australia's first peoples have used running water to dissolve toxins and remove them from potential food sources for many thousands of years.

## 4.1 Revision



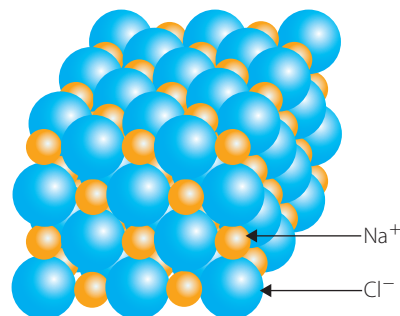
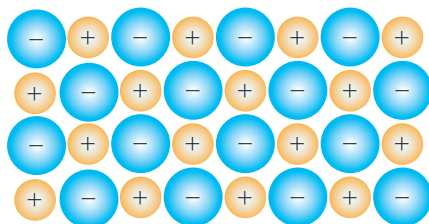
Prior knowledge

In this chapter, you will focus on the solubility of ionic compounds in water. Before you look at how ionic compounds and water interact, you will briefly revise the structure of ionic compounds and the structure of water.

### Structure of ionic compounds

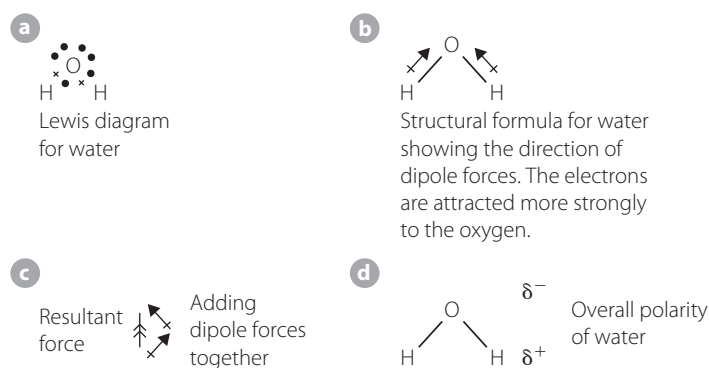
In Module 1 of the Year 11 course, you looked at the structure of ionic compounds. They have a crystalline structure in which the positive and negative ions are arranged in an orderly fashion with every positive ion being surrounded by negative ions and every negative ion being surrounded by positive ions, as shown in Figure 4.2. The electrostatic attraction between oppositely charged ions extends throughout the whole crystal. There are no separate units of NaCl, just a large array of cations and anions held together by ionic bonds.

**FIGURE 4.2** An ionic substance consists of an orderly array of positive and negative ions.



## Structure of water

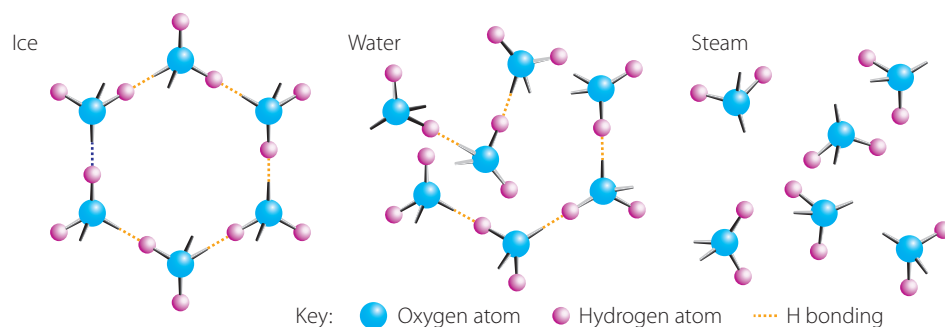
Water is composed of two hydrogen atoms covalently bonded to an oxygen atom. Water is a polar molecule because there is a large difference in electronegativity between the oxygen and hydrogen atoms within the molecule. Oxygen's strong ability to attract electrons means that the electrons in the O—H covalent bond are more attracted to oxygen. Oxygen becomes slightly negatively charged and hydrogen is left with a slightly positive charge. The hydrogen atom is so small that it also means that two molecules can get very close to each other. Figure 4.3 shows the polarity of the water molecule.



**FIGURE 4.3** Polarity of the water molecule

Since water is polar and there is a large difference in electronegativity between the oxygen and hydrogen atoms within the molecule, water displays **hydrogen bonding**, as shown in Figure 4.4.

Another property of water is its ability to act as a solvent. Pure water is liquid from 0°C to 100°C. This means that it can act as a solvent over this temperature range. Water dissolves and transports a range of materials across the whole planet and also through each cell of a living organism. Water does this by forming hydrogen bonds or **ion-dipole bonds** with a wide range of substances from salts to organic molecules such as proteins.



**FIGURE 4.4** The structure of ice compared to that of liquid water and steam, showing hydrogen bonding

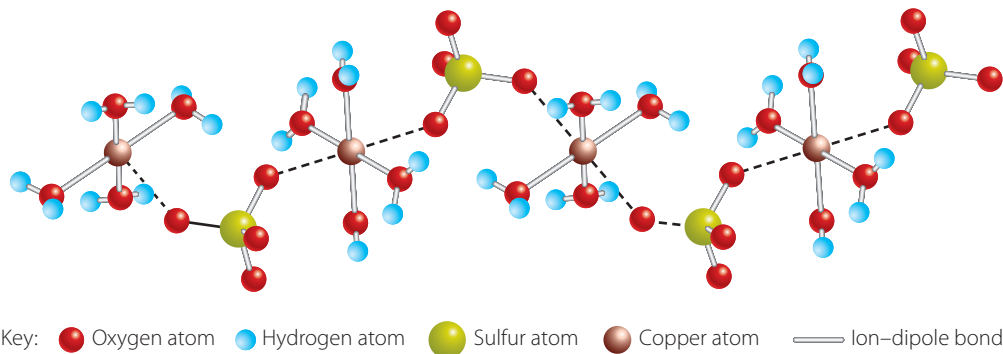
An understanding of hydrogen bonding, dipole-dipole and dispersion forces is important because it allows chemists to predict properties such as whether one substance will dissolve in another substance. Refer to chapters 6 and 10 in *Chemistry in Focus* Year 11.

## Water of crystallisation

Water of crystallisation occurs when water molecules are attracted to the ions of a salt. Many ionic compounds that crystallise out of an aqueous solution include water molecules in a regular array through the crystal lattice. The water molecules are in a set ratio to the ionic substance. These compounds are said to be hydrated. For example,  $\text{CuSO}_4 \cdot 5\text{H}_2\text{O}$  has five water molecules of crystallisation per unit of

Refer to *Chemistry in Focus Year 11*, page 119 to revise VSEPR theory.

copper(II) sulfate. The bonds between the ions and water are called ion–dipole bonds; the ion and the dipole in the water molecules form a weak bond. Water or other molecules that form dipole bonds to a metal atom are referred to as **ligands**. The water ligands take the positions around the central ion and will follow the **VSEPR theory**.  $\text{CuSO}_4 \cdot 5\text{H}_2\text{O}$  is an octahedral shape. The central ion is a cation, so the negative oxygen of water points towards the  $\text{Cu}^{2+}$ , as shown in Figure 4.5.



**FIGURE 4.5** The crystals of copper(II) sulfate consist of an octahedral arrangement of water molecules and sulfate ions around the central copper ion.

Refer to *Chemistry in Focus Year 11* Investigation 7.4 ('Empirical formula for hydrated copper sulfate').

The water of crystallisation can be evaporated by heating the hydrated compound. When all the water molecules have been removed, the compound is said to be **anhydrous**. To do this, a known mass of the hydrated compound is heated so that the mass of water removed can be determined. From this, the empirical formula of the hydrate can be calculated.

## INVESTIGATION 4.1

### Water of crystallisation

#### INTRODUCTION

Some salts are different colours in their hydrated and anhydrous forms (for example,  $\text{CuSO}_4 \cdot 5\text{H}_2\text{O}$  is blue, while anhydrous  $\text{CuSO}_4$  is white). Therefore, it is relatively easy to determine when all of the water has evaporated, so that there is only  $\text{CuSO}_4$  remaining. However, some ionic salts do not change colour when the water evaporates. Both the hydrated and anhydrous salts are the same colour, usually white. In this case, it is more challenging to determine the end point (that is, when all of the water has evaporated so that only the anhydrous salt remains).

In this investigation, you will be planning and performing an experiment to determine the formula for the hydrated salt for several ionic salts.

#### AIM

Write an aim for your investigation.

#### MATERIALS

Hydrated salts for the following ionic compounds will be provided:

- Barium chloride
- Calcium chloride
- Magnesium sulfate
- Sodium carbonate

Critical and creative thinking

Numeracy



- » Construct a materials list for your investigation, including quantities of each material that you need.  
Complete a risk assessment for your investigation

WHAT ARE THE RISKS IN DOING THIS INVESTIGATION?

HOW CAN YOU MANAGE THESE RISKS TO STAY SAFE?



#### METHOD

Devise a method for your investigation.

How will you know when the investigation has reached its end point?

#### RESULTS

Record your results in a carefully planned table.

#### ANALYSIS OF RESULTS

Analyse your data to determine the formula for each of the hydrated salts.

#### CONCLUSION

With reference to the data obtained and its analysis, write a conclusion based on the aim for this investigation.

Discuss any limitations in your methodology.

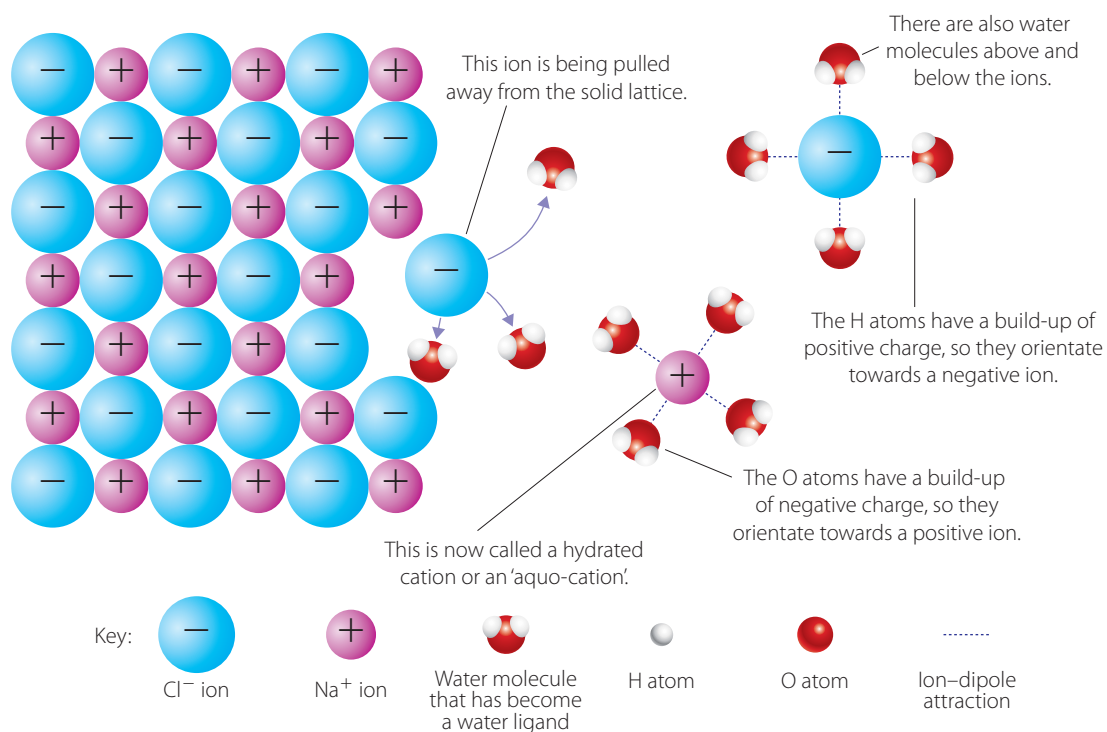
## 4.2 Dissolution of ionic compounds

Water is considered to be an important solvent. This is due to its polarity. Solutes are substances that dissolve in a solvent. The solution that is formed from a solute dissolving in a solvent is homogeneous (uniform) since the particles are too small to be seen.

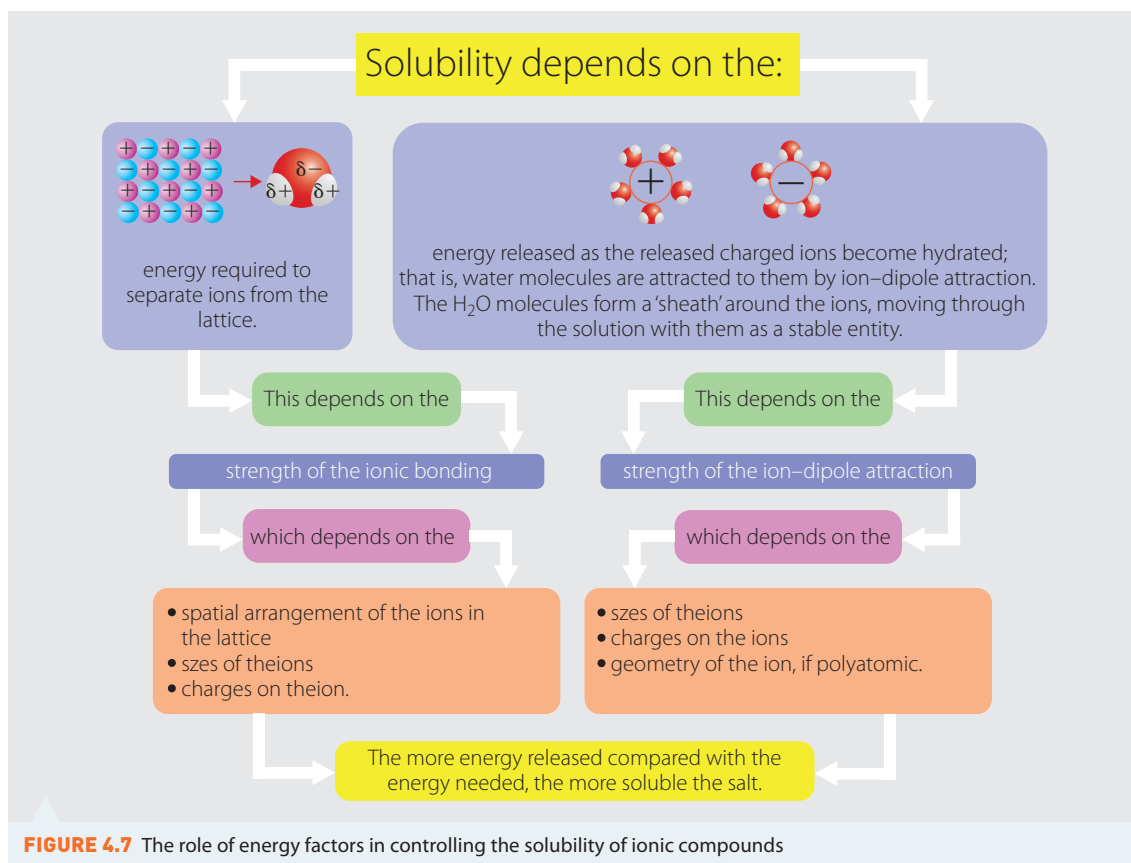
When a salt dissolves in water, ion-dipole bonds are formed. The positive part of the water molecule is attracted to the anion of the salt. More water molecules surround the anion until it is perfectly hydrated. The negative part of water is attracted to the cation and a similar process occurs until the ionic bonds within the salt crystal are broken and the salt has dissolved, as shown in Figure 4.6 (page 86).

For ionic substances to dissolve in water, the energy required to separate the ions has to be less than the energy released when the ions are hydrated, as shown in Figure 4.7 (page 86). The temperature of the solution alters both the rate at which an ionic salt will dissolve and the amount that can dissolve.

- A solute dissolves when the energy of the bonds it forms with water is lower than the energy of the bonds between water molecules or between the ions of the substance being dissolved. The energy difference explains why some ionic salts dissolve in water and some do not.



**FIGURE 4.6** A simplified model of the solution process for a sodium chloride crystal in water



- 1 Define 'ligand'.
- 2 Describe the structure of an ionic lattice.
- 3 Explain why water is a polar molecule.
- 4 Explain why water is a solvent.
- 5 Explain why some ionic compounds form hydrated salts.
- 6 Explain why sodium chloride dissolves in water but silver chloride does not.

## 4.3 Measuring solubility

The mass of a substance that dissolves depends upon temperature. The **solubility** of a solute is the maximum mass in grams that can dissolve in 100 g of the solvent at a given temperature.

When adding sugar to a cup of water, there reaches a point at which no more sugar can dissolve at a particular temperature. The extra sugar stays at the bottom of the cup. The solution is said to be saturated with sugar. Before this point was reached, it was an **unsaturated solution**.

If the water is heated, then more sugar will dissolve. If this heated solution is allowed to cool, crystals will start to precipitate again. The temperature at which this happens is the temperature at which the solution is saturated. A solution can also become supersaturated. This means that there is more solute dissolved than in a **saturated solution** at the same temperature. If this **supersaturated solution** is bumped, a sugar crystal is added or the side of the glass is scratched, then the extra sugar will precipitate out again. This is because the solution is unstable. Toffee is a supersaturated solution of sugar, so to stop the toffee crystallising, a mixture of sugars or the addition of some fats can be used to stabilise the solution.

### Solubility curves

A graph showing how much of a solute, such as a salt, can be dissolved at a particular temperature provides useful information on the solubility of a substance. Generally, as temperature increases, more salt will dissolve. This graph is called a **solubility curve**, as shown in Figure 4.8. The amount of solute is measured in grams of solute in 100 g of water.

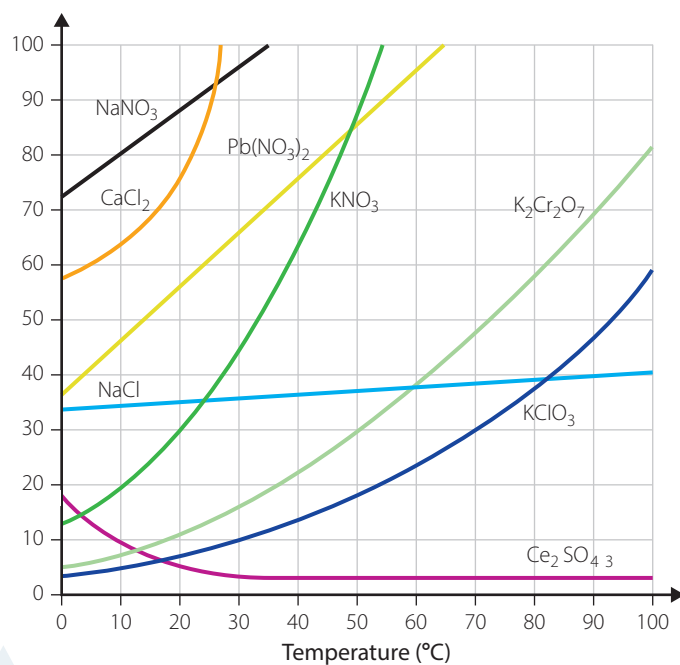


FIGURE 4.8 A selection of solubility curves for various salts



## WORKED EXAMPLE 4.1

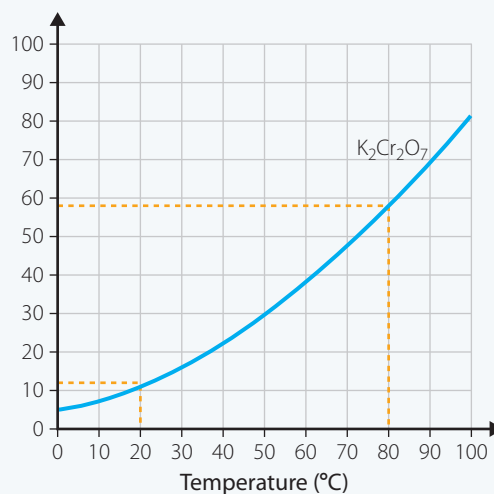
Refer to the solubility curve in Figure 4.9 for this worked example.

- How much potassium dichromate ( $K_2Cr_2O_7$ ) will dissolve at  $20^\circ C$ ?
- How much extra will dissolve at  $80^\circ C$ ?



ANSWERS	LOGIC
<p><b>1</b> At <math>20^\circ C</math>, approximately 12 g of <math>K_2Cr_2O_7</math> will dissolve in 100 g of water.</p>	<ul style="list-style-type: none"> <li>Find the curve for <math>K_2Cr_2O_7</math> on the graph. Draw a line from <math>20^\circ C</math> up to the potassium dichromate curve. Then draw a line from this point across to the y axis, as shown in Figure 4.9. This will indicate the amount that will dissolve at <math>20^\circ C</math>.</li> </ul>
<p><math>58\text{ g} - 12\text{ g} = 46\text{ g}</math></p> <p><b>2</b> The extra amount that would dissolve at <math>80^\circ C</math> is 46 g.</p>	<ul style="list-style-type: none"> <li>Similarly, if the temperature is increased to <math>80^\circ C</math>, approximately 58 g of the substance will dissolve in 100 g (or 100 mL) of water.</li> <li>This is also the amount that would crystallise out of solution if the temperature of the saturated solution was cooled from <math>80^\circ C</math> to <math>20^\circ C</math>.</li> </ul>

**FIGURE 4.9** Calculating the amounts of potassium dichromate ( $K_2Cr_2O_7$ ) that can dissolve at  $20^\circ C$  and at  $80^\circ C$ . The difference is how much extra or how much potassium dichromate will crystallise out of the solution on lowering the temperature from  $80^\circ C$  to  $20^\circ C$ .



### TRY THESE YOURSELF

Refer to Figure 4.8 (page 87) to answer questions 1–3.

- What mass of the following solutes will dissolve in 100 mL of water?
  - $K_2Cr_2O_7$  at  $50^\circ C$
  - NaCl at  $100^\circ C$
  - $NaNO_3$  at  $10^\circ C$
- Determine which of  $K_2Cr_2O_7$ , NaCl and  $NaNO_3$  is most soluble in water at  $15^\circ C$ .
- At  $60^\circ C$ , what mass of  $K_2Cr_2O_7$  and NaCl would just dissolve in 100 mL of water. For this mass at this temperature, would the solution be saturated, unsaturated or supersaturated?

## INVESTIGATION 4.2

### Deriving the solubility curve for potassium chloride

#### INTRODUCTION

This investigation can be done individually or as a class collaboration where each group collects data for one of the scenarios given in the results table.

#### AIM

To gather data to draw a solubility curve for potassium chloride.

#### MATERIALS

- Potassium chloride
- Distilled water
- 250 mL beaker
- 10 mL measuring cylinder
- Large test tubes
- Bunsen burner
- Tripod
- Gauze mat
- Bosshead and clamp
- $-10$ – $110^{\circ}$  thermometer
- Stirring rod
- Balance
- Weighing bottle
- Matches
- Test-tube rack
- Wire gauze
- Spatula
- Safety glasses

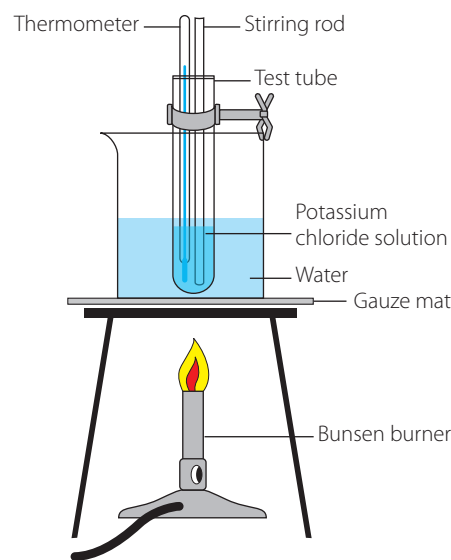
WHAT ARE THE RISKS IN DOING THIS INVESTIGATION?	HOW CAN YOU MANAGE THESE RISKS TO STAY SAFE?
The Bunsen burner will get hot.	Do not use the Bunsen burner if the gas tube is damaged. Ensure long hair is tied back and the flame is away from flammable material. If you burn yourself, place the affected part under cold running water for 20 minutes and inform your teacher.
Broken glassware will cut.	Inspect and discard any chipped or cracked glassware, no matter how small the damage. Sweep up broken glass with a brush and dustpan; do not use your fingers.



What other risks are associated with your investigation? How can you manage these?

#### METHOD

- 1 Carefully weigh out the amount of potassium chloride assigned to your group (see table on page 90).
- 2 Place the weighed potassium chloride into a test tube.
- 3 Add 10 mL of distilled water.
- 4 Half-fill the beaker with tap water, clamp the test tube securely into the beaker so that it is immersed in the water (Figure 4.10).
- 5 Warm the beaker, mixing the contents of the test tube with the stirring rod. Continue until the potassium chloride has dissolved completely.
- 6 Allow the test tube to cool. Continue to stir it until tiny flakes of potassium chloride start to appear. Note the temperature at which this occurs.



**FIGURE 4.10** Experimental set-up for determination of a solubility curve



## » RESULTS

Copy and complete the following table.

GROUP	MASS OF POTASSIUM CHLORIDE (g)	MASS OF WATER (g)	TEMPERATURE OF RECRYSTALLISATION (°C)	SOLUBILITY (g/100 g H <sub>2</sub> O)
1	3.00	10.00		
2	3.40	10.00		
3	3.80	10.00		
4	4.20	10.00		
5	4.60	10.00		
6	5.00	10.00		

## ANALYSIS OF RESULTS

- 1 Use the class results to plot a graph of solubility against temperature. Plot the temperature along the horizontal axis (0–100°C).
- 2 From the graph, predict the solubility of potassium chloride at 20°C, 40°C, 60°C and 80°C.

## DISCUSSION

- 1 Describe what happens to the solubility of potassium chloride as temperature increases.
- 2 At the point the crystals first appear, the solution is saturated. Define 'saturated'.
- 3 At what temperature would 10 g of potassium chloride saturate 50 g of water?
- 4 If a saturated solution of potassium chloride at 90°C is cooled to 10°C, how many grams of potassium chloride would crystallise out of 100 g of water?
- 5 If the theoretical value for the solubility of potassium chloride at 50°C is 50 g/100 g, what percentage error does your experiment have?

$$\text{Percentage error} = \frac{\text{Experimental value} - \text{true value}}{\text{True value}} \times 100$$

- 6 List possible sources of errors in your experiment.
- 7 Describe modifications to the experiment that could improve the accuracy.



Solubility and solutions

- The solubility of a solute is the maximum mass in grams that can dissolve in 100 g of the solvent at a given temperature.
- A solubility curve shows how much of a solute, such as a salt, can be dissolved at a particular temperature.

## 4.4

## Australia's first peoples – removing toxicity from foods

Australia's first peoples, the Aboriginal and Torres Strait Islander Peoples, had a deep understanding of the land on which they lived. They used plants for many purposes, including:



- ▶ shelter by building huts
- ▶ transport, using canoes
- ▶ weapons, such as shields and fighting sticks
- ▶ hunting, using spears
- ▶ fishing, using both harpoons and spears
- ▶ food preparation and storage, using baskets and sticks
- ▶ food – plants were a major source of carbohydrates
- ▶ firewood and firesticks
- ▶ water carriers.

Australia's first peoples ate nearly 700 different species of plants. Of these, more than 300 required some form of processing, while about 20 required complex processing. Complex processing referred to the time required for the processing to occur, generally more than half a day. This usually involved leaching due to either **toxins** or **unpalatable substances** or a combination of the two. Toxins referred to substances that had harmful effects on people or even caused death, while unpalatable substances had either an unpleasant taste or smell. However, while the percentage of species requiring complex processing was small overall, in some more localised areas it was a larger proportion of the plant species. This was especially true in tropical rainforest ecosystems.

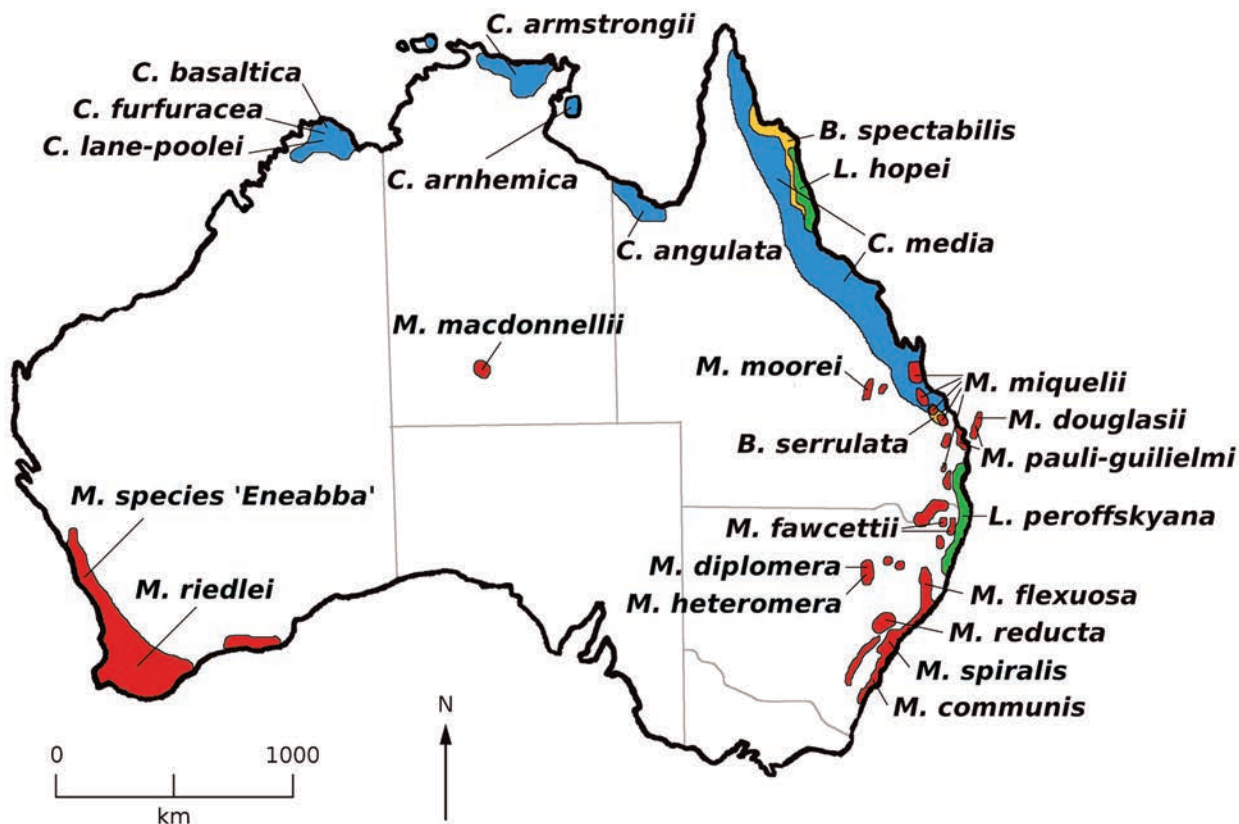
In the tropical rainforests of north-eastern Queensland, about two-thirds of the edible plant species did not contain any toxic substances. In some cases, parts of the plants were toxic but these were not the parts that were eaten, while in other cases, the toxin was present in very small quantities, below the threshold that could create health issues for humans if they ate small quantities of these plants. For example, *Planchonia careya*, commonly referred to as the cocky apple, had fruit that was edible, though its bark and roots contained toxins.

Australia's first peoples developed an understanding about how to process plants to remove or deactivate the toxins. Some plants required pounding and roasting, while others required more extensive processing such as washing or leaching. This enabled them to increase the number of species that they could use as food sources – it increased variety in their diet. For example, the cycad, *Bowenia spectabilis*, found in tropical north-eastern Queensland is the most toxic cycad in the world with the highest level of mercury (Figure 4.11). However, Australia's first peoples ate the roots of this plant. It may have provided a food source at a time of the year when other foods were less readily available.



**FIGURE 4.11** *Bowenia spectabilis*, a cycad found in north-eastern Queensland

Cycads are commonly found in tropical rainforests, as shown in the distribution map in Figure 4.12. They produce large amounts of fruit. However, they contain azoxyglycosides, which cause gastrointestinal and liver disorders, including cancer. They also strip the insulating layer of myelin from around nerves, which causes the nerve impulses to leak and leads to unpredictable movements. Azoxyglycosides can even lead to death.

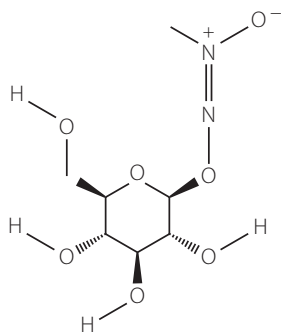


**FIGURE 4.12** Distribution of cycad genera in Australia – *Bowenia* (yellow), *Cycas* (blue), *Macrozamia* (red) and *Lepidozamia* (green)

Cycads regenerate quickly after fire; hence, they are an available food source when other plants are not available since they take longer to regenerate. So, developing techniques to remove the toxins in cycads improved the lifestyle of Australia's first peoples.

Cycads and other very toxic plants, such as the yellow walnut (*Beilschmiedia bancroftii*), required complex processing. The first step was to cook the plant, then in some cases it was pounded, sliced or ground into a meal; however, the most important step in removing the toxins was **leaching**.

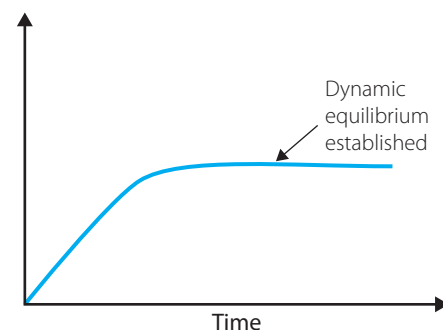
Leaching involves the use of water to dissolve the toxin and remove it from the plant. Hence, it is used when the toxins are water soluble and there is a readily available water supply. Cycasin's solubility is  $56.6\text{gL}^{-1}$  of water. Therefore, leaching was a very effective process for removing the toxin. The molecular structure of cycasin is shown in Figure 4.13. Australia's first peoples placed the parts of the plants to be leached (for example, seeds or kernels) in a finely woven basket made from lawyer cane (*Calamus australis*), which was placed in a flowing creek so that the toxin would dissolve and flow away with the water. This process could take as little as a few hours or as long as several days. Accounts vary regarding the treatment, especially how long the leaching process occurred.



**FIGURE 4.13** The toxin, cycasin, methylazoxymethanol glucoside, is commonly found in cycads.

Leaching today usually involves placing an object, such as an artefact recovered from a shipwreck, in a container of water. The salts in the artefact dissolve in the water, and hence, the concentration of salts increases until the water cannot dissolve any more salts. Dynamic equilibrium is reached – the rate at which salts are dissolving in the water is equal to the rate at which the salts are moving back into the artefact (Figure 4.14). At this point, the artefact is removed from the container, the solution is discarded and the container is refilled with fresh water. The artefact is returned to the container and the process continues.

Australia's first peoples did not have to replace the water since they placed their baskets in flowing creeks, so the toxins were carried away with the water and it never reached dynamic equilibrium.



**FIGURE 4.14** A graph indicating the change in concentration of ions over time during leaching. It also indicates when dynamic equilibrium occurs and it is time to replace the water.

- Australia's first peoples developed an understanding about how to process plants to remove or deactivate the toxins.

- 1 Define the following terms.
  - a Solubility
  - b Toxin
- 2 Distinguish between a saturated and a supersaturated solution.
- 3 Use Figure 4.8 (page 87) to answer the following questions.
  - a What is the solubility of lead(II) nitrate at 20°C?
  - b Describe the effect on the solubility of cerium sulfate of increasing the temperature from 0°C to 30°C.
  - c Quantitatively compare the solubility of potassium dichromate at 50°C to its solubility at 90°C.
  - d Justify the shape of the graph for the solubility of cerium sulfate as the temperature is increased from 50°C to 90°C.
- 4 Using Figure 4.8, determine how many moles of potassium chlorate will dissolve at 70°C.
- 5 Explain why leaching was an effective method for removing toxins from cycads.

**CHECK YOUR  
UNDERSTANDING**

4.3

4.4

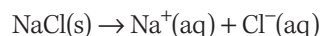


## 4.5 Solubility rules

As you learnt in chapter 1 of *Chemistry in Focus Year 11*, solutions are defined as homogeneous mixtures. The most commonly occurring natural solutions have water as the solvent and a wide variety of different solutes, including solids, liquids and gases. Oceans are solutions of different compounds, many of which are ionic, dissolved in water. The chemical reactions that are responsible for maintaining all living things occur in water solutions. Solutions of substances dissolved in water are called **aqueous solutions**. The term 'aqueous' comes from the Latin *aqua*, meaning water.

When ionic substances dissolve in water, they dissociate. This means they separate into their ions, which are then able to move freely and independently of each other through the solution.

For example, when sodium chloride (NaCl) dissolves in water, it separates into  $\text{Na}^+$  ions and  $\text{Cl}^-$  ions. This can be represented as:



Although most ionic compounds are soluble in water, they do not all dissolve to the same extent.

Chemists use the terms 'soluble', 'insoluble' and 'sparingly soluble' to categorise the solubility of different compounds. 'Soluble' means that a compound dissolves to more than  $10\text{gL}^{-1}$  (or  $1\text{g}/100\text{mL}$ ), 'insoluble' means that it dissolves to less than  $1\text{gL}^{-1}$ , and 'sparingly soluble' means that it dissolves in the range  $1\text{gL}^{-1}$  to  $10\text{gL}^{-1}$ .

Units can be expressed as either  $\text{gL}^{-1}$  or  $\text{g}/100\text{mL}$ . Both have the same meaning.



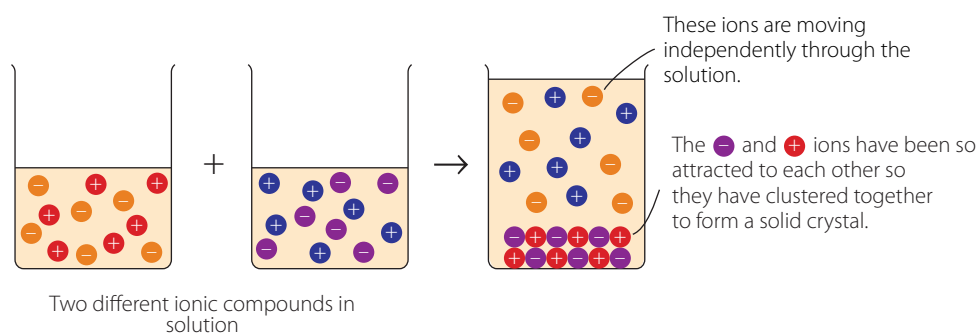
**FIGURE 4.15** A silver chloride precipitate

### Precipitation reactions

In chapter 10 of *Chemistry in Focus Year 11*, you saw that when solutions of certain ionic compounds were mixed, they sometimes reacted to produce a solid called a **precipitate**. This type of reaction was called a **precipitation reaction**.

For example, when sodium chloride solution is added to silver nitrate solution, a white solid of silver chloride is formed. When the solution of  $\text{Na}^+$  and  $\text{Cl}^-$  ions is mixed with the solution of  $\text{Ag}^+$  and  $\text{NO}_3^-$  ions, the result is a solution containing all the ions moving randomly throughout (that is, no precipitate is formed). Remember that each of the ions is surrounded by water molecules. The  $\text{Ag}^+$  and  $\text{Cl}^-$  ions are more strongly attracted to each other than they are to the water, so they cluster together in groups and form a solid, which precipitates out of solution, as shown in Figures 4.15 and 4.16.

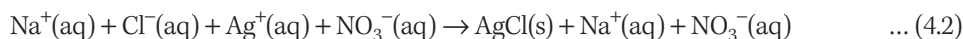
Key:  $\oplus$  Silver ions  
 $\ominus$  Nitrate ions  
 $\oplus$  Sodium ions  
 $\ominus$  Chloride ions



**FIGURE 4.16** Explaining the formation of silver chloride precipitate (**Note:** This is a simplified model of the association process.)

The  $\text{Na}^+$  and  $\text{NO}_3^-$  ions are not involved in the reaction and remain in the solution as ions. Ions that are not involved in a reaction are called **spectator ions**.

The equation for this reaction can be written in a number of different ways, which may include or omit the spectator ions:



Equation 4.1 is an overall equation. It shows all the reactants and products as actual neutral compounds. Equation 4.2 is a **complete ionic equation**. It shows all the ions present in the solution. Equation 4.3 is the **net ionic equation**. It shows only the reacting ions. Removing the spectator ions from the complete ionic equation produces the net ionic equation. This equation most accurately represents the reaction taking place, so is most commonly used to represent precipitation reactions.

## Predicting precipitation

By systematically mixing solutions that contain known cations and anions, chemists have experimentally determined which compounds are soluble and which form a precipitate (are insoluble). These results have been summarised into a table of solubility data that can then be used to predict whether or not precipitation will occur when two known solutions are mixed. Sometimes, when only a small amount of precipitate forms, it does not settle to the bottom but stays in suspension and makes the mixture look cloudy (Figure 4.17).



FIGURE 4.17 Solutions and suspensions



### Preitaiton animation

View this animation and predict when a precipitate will form.

## INVESTIGATION 4.3

### Investigating precipitation reactions

#### INTRODUCTION

Solubility rules can be formulated from experimental result. In this experiment, you will determine which mixtures of solutions form precipitates and use these results to construct solubility rules. These can then be compared with theoretical data.

#### AIM

To compare the solubility of a range of ionic substances through precipitation reactions.

#### MATERIALS

- Cations (all  $0.1 \text{ mol L}^{-1}$  except lead(II) nitrate, which is  $0.02 \text{ mol L}^{-1}$ ) in dropper bottle: sodium nitrate ( $\text{NaNO}_3$ ) silver nitrate ( $\text{AgNO}_3$ ) lead(II) nitrate ( $\text{Pb}(\text{NO}_3)_2$ ) ammonium nitrate ( $\text{NH}_4\text{NO}_3$ ) magnesium sulfate ( $\text{MgSO}_4$ ) iron(II) sulfate ( $\text{FeSO}_4$ ) copper(II) sulfate ( $\text{CuSO}_4$ ) zinc sulfate ( $\text{ZnSO}_4$ ) aluminum sulfate ( $\text{Al}_2\text{SO}_4 \cdot 3\text{H}_2\text{O}$ ) barium chloride ( $\text{BaCl}_2$ ) calcium chloride ( $\text{CaCl}_2$ ) iron(III) chloride ( $\text{FeCl}_3$ )



Critical and creative thinking



- » Anions (all 0.1 mol L<sup>-1</sup>) in dropper bottles: potassium nitrate (KNO<sub>3</sub>), potassium chloride (KCl), sodium sulfate (Na<sub>2</sub>SO<sub>4</sub>), sodium carbonate (Na<sub>2</sub>CO<sub>3</sub>), sodium acetate (NaCH<sub>3</sub>COO), sodium hydroxide (NaOH)
- » Overhead projector sheet
- » Finesline permanent marker
- » Safety glasses



WHAT ARE THE RISKS IN DOING THIS INVESTIGATION?	HOW CAN YOU MANAGE THESE RISKS TO STAY SAFE?
Chemicals could splash on your skin or into your eyes.	Wear safety glasses and avoid contact with skin. If contact occurs, wash thoroughly with soap and water.
Some chemicals are not able to be disposed of down the sink.	You can wipe the chemicals up with a paper towel. Refer to safety data sheets or use the RiskAssess program to identify alternative methods of disposal.

What other risks are associated with your investigation? How can you manage these?

#### METHOD

- 1 Draw up a grid on an overhead projector sheet with anions written across the top and cations down the side.
- 2 Place the grid against a dark background (a dark laboratory bench or sheet of black paper).
- 3 Place one drop each of the appropriate chemicals on the grid. There should be two drops (one solution on top of the other solution) in each square of the grid.
- 4 Record observations.

#### RESULTS

Record all observations in an appropriate format.

#### ANALYSIS OF RESULTS

Summarise your results into statements such as 'All nitrates are...'

#### DISCUSSION

- 1
  - a Compare the results of the experiment with the solubility rules in Table 4.1 (page 97).
  - b What, if any, were the discrepancies between your results and Table 4.1? Suggest a reason for these discrepancies and a way of resolving them.
- 2 Write a balanced net ionic equation for each of the reactions in which a precipitate was obtained.

#### CONCLUSION

Summarise the solubility rules according to your results.

Table 4.1 summarises the solubility of common ionic compounds. The table applies to the cations in groups 1 and 2, NH<sub>4</sub><sup>+</sup>, Al<sup>3+</sup>, Cr<sup>3+</sup>, Mn<sup>2+</sup>, Fe<sup>2+</sup>, Fe<sup>3+</sup>, Cu<sup>2+</sup>, Co<sup>2+</sup>, Ni<sup>2+</sup>, Ag<sup>+</sup>, Zn<sup>2+</sup>, Sn<sup>2+</sup>, Cd<sup>2+</sup> and Pb<sup>2+</sup>. The table is organised in terms of the solubility of various anions. An additional useful generalisation is that all group 1 and NH<sub>4</sub><sup>+</sup> salts are soluble.

**TABLE 4.1 Solubility of common ionic substances**

SOLUBLE ANIONS	EXCEPTIONS	INSOLUBLE ANIONS	EXCEPTIONS
$\text{NO}_3^-$	None	$\text{OH}^-$	Group 1, $\text{NH}_4^+$ , $\text{Ba}^{2+}$ , $\text{Sr}^{2+}$ soluble; $\text{Ca}^{2+}$ slightly soluble
$\text{CH}_3\text{COO}^-$	$\text{Ag}^+$ slightly soluble	$\text{O}^{2-}$	Group 1, $\text{NH}_4^+$ , $\text{Ba}^{2+}$ , $\text{Sr}^{2+}$ , $\text{Ca}^{2+}$ soluble
$\text{Cl}^-$	$\text{Ag}^+$ insoluble $\text{Pb}^{2+}$ slightly soluble	$\text{S}^{2-}$	Groups 1 and 2, $\text{NH}_4^+$ soluble
$\text{Br}^-$	$\text{Ag}^+$ insoluble $\text{Pb}^{2+}$ slightly soluble	$\text{CO}_3^{2-}$	Group 1, $\text{NH}_4^+$ soluble
$\text{I}^-$	$\text{Ag}^+$ , $\text{Pb}^{2+}$ insoluble	$\text{SO}_3^{2-}$	Group 1, $\text{NH}_4^+$ soluble
$\text{SO}_4^{2-}$	$\text{Ba}^{2+}$ , $\text{Pb}^{2+}$ , $\text{Sr}^{2+}$ insoluble $\text{Ag}^+$ , $\text{Ca}^{2+}$ slightly soluble	$\text{PO}_4^{3-}$	Group 1, $\text{NH}_4^+$ soluble



Precipitation challenge

## Applying solubility data

Chemists are often asked to identify substances such as cations and anions that may have contaminated food, soil and water. Precipitation reactions are useful for finding out whether a particular anion or cation is present; for example, chemists could use precipitation reactions to test for lead or cadmium in water supplies. Precipitation reactions can also be used to remove unwanted substances from water.

The data in Table 4.1 can be used to predict whether or not a precipitate will form when particular solutions are mixed.



**FIGURE 4.18** Chemists working in an analytical laboratory

### WORKED EXAMPLE 4.2

Use Table 4.1 to answer these questions.

- What precipitate, if any, will form when aqueous solutions of magnesium iodide and silver nitrate are mixed? If a precipitate forms, write the neutral species and net ionic equations for the reaction.
- Select a reagent that could be used to precipitate the cation in  $\text{BaBr}_2$ , explaining your selection.



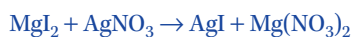
Critical and creative thinking

#### ANSWERS

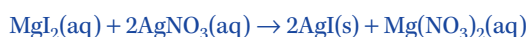
Magnesium iodide ( $\text{MgI}_2$ )

Silver nitrate ( $\text{AgNO}_3$ )

- Precipitate is  $\text{AgI}$ .



Neutral species equation:



#### LOGIC

- Write the formula of the compounds present.
- Predict the products by swapping the partners of the reacting compounds and check that the formulae are correct.
- Use Table 4.1 to see if either of the products is insoluble. All nitrates are soluble, all iodides are soluble except  $\text{Ag}^+$  and  $\text{Pb}^{2+}$ , so  $\text{AgI}$  will precipitate.

ANSWERS	LOGIC
<p>Net ionic equation:</p> $\text{Ag}^+(\text{aq}) + \Gamma(\text{aq}) \rightarrow \text{AgI}(\text{s})$	<ul style="list-style-type: none"> <li>Write the required equations, checking they are balanced.</li> </ul>
<p><math>\text{Ba}^{2+}</math> and <math>\text{Br}^-</math> are the ions present in solution.</p> <p><b>2</b> <math>\text{Ba}^{2+}</math> is the ion to be precipitated.</p> <p><math>\text{SO}_4^{2-}</math>, <math>\text{S}^{2-}</math>, <math>\text{CO}_3^{2-}</math>, <math>\text{SO}_3^{2-}</math> and <math>\text{PO}_4^{3-}</math> are suitable anions to produce an insoluble compound with <math>\text{Ba}^{2+}</math>.</p> <p><math>\text{SO}_4^{2-}</math> would be a suitable anion to precipitate with <math>\text{Ba}^{2+}</math>.</p> <p><math>\text{Na}^+</math> would be a suitable cation for the reagent since it is soluble with both <math>\text{SO}_4^{2-}</math> and <math>\text{Br}^-</math>.</p> <p><math>\text{Na}_2\text{SO}_4</math> can be used to precipitate <math>\text{Ba}^{2+}</math> from a solution of <math>\text{BaBr}_2</math>.</p>	<ul style="list-style-type: none"> <li>Identify the ions present and the one to be precipitated:</li> <li>Use Table 4.1 to identify an anion that could be used to precipitate the identified cation.</li> <li>Choose one of the anions and identify a cation to form a compound. Check that the cation does not react with the anion from the original compound.</li> <li>Generally, it is best to choose a cation from group 1 or <math>\text{NH}_4^+</math> because compounds of these are soluble. It would be incorrect to choose <math>\text{Ag}^+</math> and <math>\text{Pb}^{2+}</math> since they precipitate with <math>\text{Br}^-</math>.</li> <li>Identify the reagent and write the formula.</li> </ul>

#### TRY THESE YOURSELF

Use Table 4.1 to answer these questions.

- When solutions of potassium sulfide and cobalt acetate are mixed, which salt, if any, will precipitate? If a precipitate does form, write the neutral species and net ionic equations.
- Name and give the formula of the precipitate (if any) that forms when each of the following pairs of substances are mixed.
  - Copper(II) chloride and potassium hydroxide
  - Sodium carbonate and ammonium sulfate
  - Lead(II) nitrate and copper(II) sulfate
- What solution would you mix with calcium chloride to obtain a precipitate of the cation?

## INVESTIGATION 4.4



Critical and creative thinking

### Identifying ionic compounds

#### INTRODUCTION

The labels on the bottles of five different chemicals have fallen off. The bottles have been labelled A, B, C, D and E. The chemicals are known to be ammonium hydroxide, potassium iodide, sodium carbonate, silver nitrate and zinc sulfate. You have been asked to identify what is in each bottle.

#### AIM

Write an aim for your investigation.



## » MATERIALS

Devise a materials list for your investigation. Make sure you identify quantities of each material that you need. Complete a risk assessment for your investigation.

WHAT ARE THE RISKS IN DOING THIS INVESTIGATION?

HOW CAN YOU MANAGE THESE RISKS TO STAY SAFE?



## METHOD

Write your method in a logical sequence of steps. **Hint:** You need to use solubility rules.

## RESULTS

Record your observations in a carefully planned table.

## ANALYSIS OF RESULTS

Consider what your results show. Look at theoretical predictions you made about possible precipitates and compare your results with these. Are there any differences or inconclusive results? Do you need to repeat any tests? Do you need to use an alternative solution for confirmation?

## CONCLUSION

With reference to the data obtained and its analysis, write a conclusion based on the aim of this investigation.

- When ionic substances dissolve in water, they dissociate.
- A precipitation reaction is when solutions of certain ionic compounds are mixed to produce a solid.
- A complete ionic equation shows all the ions present in the solution.
- An overall equation shows all the reactants and products as actual neutral compounds.
- A net ionic equation shows only the reacting ions.

- 1 Define 'precipitate'.
- 2 Explain what is meant by a 'spectator ion'.
- 3 Which of the following substances are soluble in water?
  - a Sodium hydroxide
  - b Aluminium oxide
  - c Copper(II) sulfate
  - d Silver carbonate
  - e Lithium chloride
- 4 Name a different pair of substances (using suitable amounts) that you could dissolve in one sample of water to produce a solution identical with that containing:
  - a potassium chloride and zinc nitrate
  - b ammonium sulfate and sodium carbonate
  - c magnesium bromide and copper(II) sulfate.

CHECK YOUR UNDERSTANDING

4.5





- 5 Write overall equations for the reactions (if any) that occur when solutions of the following pairs of substances are mixed. If there is no reaction, write 'NR'.
- Sodium chloride and silver nitrate
  - Copper(II) sulfate and potassium hydroxide
  - Nickel chloride and potassium sulfate
  - Sodium carbonate and iron(II) sulfate
  - Zinc nitrate and ammonium sulfide
  - Potassium carbonate and calcium chloride
- 6 Solutions of which substances would you mix to prepare the following compounds by precipitation? Write equations for your reactions.
- Magnesium carbonate
  - Lead sulfate
  - Silver bromide
- 7 Separate portions of an unknown solution (A) formed precipitates when potassium carbonate and sodium hydroxide solutions were added to them, but did not give precipitates when solutions of sodium chloride or ammonium sulfate were added. Solution A could have contained which of the following?
- $\text{Pb}^{2+}, \text{Zn}^{2+}, \text{Cu}^{2+}$
  - $\text{Mg}^{2+}, \text{Al}^{3+}, \text{Zn}^{2+}$
  - $\text{Mg}^{2+}, \text{Ba}^{2+}, \text{Al}^{3+}$
  - $\text{Cu}^{2+}, \text{Zn}^{2+}, \text{Ag}^+$
- 8 Describe tests to determine whether a solution contained:
- lead nitrate or barium nitrate
  - copper(II) sulfate or iron(II) sulfate.

## 4.6 Solubility equilibrium

In chapter 2 of *Chemistry in Focus Year 12*, you learnt about equilibrium reactions and in chapter 3, you learnt how to calculate the equilibrium constant and its meaning in terms of the ratio of reactants to products when the reaction reaches equilibrium. Now it is time to apply these concepts to ionic compounds when they dissolve in water.

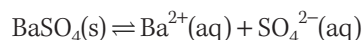
In section 4.3, you saw that different ionic compounds have different solubility and that the solubility was affected by temperature. In the previous section, the terms 'soluble', 'sparingly soluble' and 'insoluble' were defined. Insoluble is a relative term, defined as having a solubility of less than  $1 \text{ g L}^{-1}$ .

In reality, no ionic compound is completely insoluble in water. However, very little of the ionic compound dissolves before it reaches saturation. At this point, the ions of the ionic salt and the solid reach dynamic equilibrium – the rate at which ions are breaking away from the ionic lattice is equal to the rate at which ions are rejoining the lattice.

This can be represented by the equation:



An example would be barium sulfate:



The equation is always written with the solid on the left side of the arrows and the ions on the right side of the arrows. Since this is a heterogeneous equilibrium, only the ions are included in the equilibrium expression. The equilibrium constant for this type of system is called a **solubility product** and it is denoted

by the symbol  $K_{sp}$ . This symbol can only be used if the system is at equilibrium. The equilibrium expression for barium sulfate is:

$$K_{sp} = [\text{Ba}^{2+}] \times [\text{SO}_4^{2-}]$$

The equilibrium expression is written in the same way as the other equilibrium expressions in chapter 3. It includes the concentration of the chemical species raised to the power of the coefficient in the balanced chemical equation. Hence, the equilibrium expression for equation 4.4 is given in equation 4.5:

$$K_{sp} = [\text{A}^{2+}] \times [\text{B}^{-2}] \quad \dots (4.5)$$

Equilibrium systems will only occur for 'sparingly soluble' or 'insoluble' salts. Hence, equilibrium expressions are only written for these types of salts.

### WORKED EXAMPLE (4.3)

Write the equilibrium expression for each of the following insoluble compounds.

1 Calcium hydroxide

2 Iron(II) phosphate



Numeracy



Critical and creative thinking

ANSWER	LOGIC
<p>1 <math>\text{Ca}(\text{OH})_2(\text{s}) \rightleftharpoons \text{Ca}^{2+}(\text{aq}) + 2\text{OH}^{-}(\text{aq})</math></p> $K_{sp} = [\text{Ca}^{2+}] \times [\text{OH}^{-}]^2$	<ul style="list-style-type: none"> <li>▪ Write the balanced chemical equation for the compound and its ions.</li> <li>▪ Write the equilibrium expression for this heterogeneous system. Remember to:               <ul style="list-style-type: none"> <li>– only include aqueous species</li> <li>– raise each species to the power of its coefficient in the balanced chemical equation.</li> </ul> </li> </ul>
<p>2 <math>\text{Fe}_3(\text{PO}_4)_2(\text{s}) \rightleftharpoons 3\text{Fe}^{2+}(\text{aq}) + 2\text{PO}_4^{3-}(\text{aq})</math></p> $K_{sp} = [\text{Fe}^{2+}]^3 \times [\text{PO}_4^{3-}]^2$	<ul style="list-style-type: none"> <li>▪ Write the balanced chemical equation for the compound and its ions.</li> <li>▪ Write the equilibrium expression for this heterogeneous system. Remember to:               <ul style="list-style-type: none"> <li>– only include aqueous species</li> <li>– raise each species to the power of its coefficient in the balanced chemical equation.</li> </ul> </li> </ul>

#### TRY THESE YOURSELF

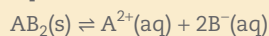
Write the equilibrium expression for each of the following insoluble compounds.

1 Calcium carbonate

2 Lead(II) chloride

3 Magnesium phosphate

- Dynamic equilibrium is when the rate at which ions are breaking away from the ionic lattice is equal to the rate at which ions are rejoining the lattice. It is shown by the expression:



- 1 Define 'solubility product'.
- 2 Explain why there is only a numerator term for expressions for solubility products.
- 3 Use Table 4.1 (page 97) to determine whether it is appropriate to write an equilibrium expression for the following salts.
  - a Sodium nitrate
  - b Strontium sulfide
  - c Silver acetate
  - d Calcium bromide
  - e Ammonium carbonate
  - f Aluminium sulfite
  - g Cadmium sulfide
- 4 Write the equilibrium expressions for the following insoluble compounds.
  - a Zinc sulfide
  - b Silver carbonate
  - c Vanadium(III) hydroxide
- 5 Justify why only insoluble and sparingly soluble salts reach dynamic equilibrium.

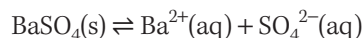
## 4.7 Relationship between the $K_{sp}$ and solubility

When a salt is dissolved in distilled water, there is a direct relationship between the solubility product and the concentration of each of the ions measured in  $\text{mol L}^{-1}$ , sometimes referred to as the **molar solubility**. This only occurs when there are no other contaminants present, and only the salt and water are present.

### Using molar solubility to determine the $K_{sp}$

The solubility of barium sulfate ( $\text{BaSO}_4$ ) is  $0.00025\text{ g}/100\text{ g}$  of water at  $298\text{ K}$ . This is a measure of how much barium sulfate can dissolve before a precipitate forms. This data can be used to determine the solubility product for barium sulfate. The following steps should be used:

- Write the balanced equation for the solubility of the salt:



- Convert the solubility data into  $\text{mol L}^{-1}$ :

$$\text{Solubility of BaSO}_4 = 0.00025\text{ g}/100\text{ g water} = 0.0025\text{ g L}^{-1}$$

$$\text{Molar mass of BaSO}_4 = 233.4\text{ g}$$

$$n = \frac{\text{mass}}{\text{molar mass}} = \frac{0.0025}{233.4} = 1.07 \times 10^{-5}\text{ mol}$$

$$\text{Solubility of BaSO}_4 = 1.07 \times 10^{-5}\text{ mol L}^{-1}$$

- Determine the concentration for each of the ions:

Using mole ratios from the balanced equation, 1 mole of  $\text{BaSO}_4$  ionises to form 1 mole of  $\text{Ba}^{2+}$  ions and 1 mole of  $\text{SO}_4^{2-}$  ions.

Therefore,  $1.07 \times 10^{-5} \text{ mol L}^{-1}$  of  $\text{BaSO}_4$  ionises to form  $1.07 \times 10^{-5} \text{ mol L}^{-1}$  of  $\text{Ba}^{2+}$  ions and  $1.07 \times 10^{-5} \text{ mol L}^{-1}$  of  $\text{SO}_4^{2-}$  ions.

- Write the equilibrium expression:

$$K_{sp} = [\text{Ba}^{2+}] \times [\text{SO}_4^{2-}]$$

- Substitute data into the equilibrium expression to calculate  $K_{sp}$ :

$$K_{sp} = [1.07 \times 10^{-5}] \times [1.07 \times 10^{-5}] = [1.07 \times 10^{-5}]^2 = 114 \times 10^{-10}$$

### WORKED EXAMPLE 4.4



Numeracy



Critical and creative thinking

The solubility of zinc hydroxide is 0.001 g/100 g water at 298 K. Calculate the  $K_{sp}$  for zinc hydroxide.

ANSWER	LOGIC
$\text{Zn}(\text{OH})_2(\text{s}) \rightleftharpoons \text{Zn}^{2+}(\text{aq}) + 2\text{OH}^{-}(\text{aq})$	<ul style="list-style-type: none"> <li>Write the balanced equation for the solubility of the salt.</li> </ul>
Solubility of $\text{Zn}(\text{OH})_2 = 0.001 \text{ g}/100 \text{ g H}_2\text{O}$  Solubility of $\text{Zn}(\text{OH})_2 = 0.01 \text{ g L}^{-1}$  Molar mass of $\text{Zn}(\text{OH})_2 = 99.4 \text{ g}$  $n = \frac{\text{mass}}{\text{molar mass}} = \frac{0.01}{99.4} = 1.01 \times 10^{-4} \text{ mol}$  Solubility of $\text{Zn}(\text{OH})_2 = 1.01 \times 10^{-4} \text{ mol L}^{-1}$	<ul style="list-style-type: none"> <li>Convert the solubility data into <math>\text{mol L}^{-1}</math>.</li> </ul>
$[\text{Zn}^{2+}] = 1.01 \times 10^{-4} \text{ mol L}^{-1}$  $[\text{OH}^{-}] = 2 \times 1.01 \times 10^{-4} = 2.02 \times 10^{-4} \text{ mol L}^{-1}$	<ul style="list-style-type: none"> <li>Determine the concentration for each of the ions.</li> <li>Using mole ratios from the balanced equation, 1 mole of <math>\text{Zn}(\text{OH})_2</math> ionises to form 1 mole of <math>\text{Zn}^{2+}</math> ions and 2 moles of <math>\text{OH}^{-}</math> ions. Therefore, <math>1.01 \times 10^{-4} \text{ mol L}^{-1}</math> of <math>\text{Zn}(\text{OH})_2</math> ionises to form <math>1.01 \times 10^{-4} \text{ mol L}^{-1}</math> of <math>\text{Zn}^{2+}</math> ions and <math>2 \times 1.01 \times 10^{-4} \text{ mol L}^{-1}</math> (i.e. <math>2.02 \times 10^{-4} \text{ mol L}^{-1}</math>) of <math>\text{OH}^{-}</math> ions.</li> </ul>
$K_{sp} = [\text{Zn}^{2+}] \times [\text{OH}^{-}]^2$	<ul style="list-style-type: none"> <li>Write the equilibrium expression.</li> </ul>
$K_{sp} = [1.01 \times 10^{-4}] \times [2.02 \times 10^{-4}]^2 = 4.12 \times 10^{-12}$	<ul style="list-style-type: none"> <li>Substitute data into equilibrium expression to calculate <math>K_{sp}</math>.</li> </ul>

#### TRY THESE YOURSELF

- The molar solubility of iron(II) sulfide is 0.0006 g/100 g of water at 25°C. Calculate the  $K_{sp}$  for iron(II) sulfide.
- The molar solubility of calcium phosphate is 0.002 g/100 g of water at 25°C. Calculate the  $K_{sp}$  for calcium phosphate.

## Using $K_{sp}$ to determine the solubility

Conversely, if the  $K_{sp}$  is given, the concentration of each of the ions can be determined. In this case, you need to use some algebra to assist with the calculation.

### WORKED EXAMPLE (4.5A)

The  $K_{sp}$  for manganese(II) carbonate is  $2.24 \times 10^{-11}$  at  $25^\circ\text{C}$ . Calculate the concentrations of the manganese ions and the carbonate ions in a saturated aqueous solution of manganese(II) carbonate.



Numeracy



Critical and creative thinking

ANSWER	LOGIC
$\text{MnCO}_3(\text{s}) \rightleftharpoons \text{Mn}^{2+}(\text{aq}) + \text{CO}_3^{2-}(\text{aq})$	<ul style="list-style-type: none"> <li>Write the balanced equation for the solubility of the salt.</li> </ul>
$[\text{Mn}^{2+}] = s \text{ mol L}^{-1}$ $[\text{CO}_3^{2-}] = s \text{ mol L}^{-1}$	<ul style="list-style-type: none"> <li>Determine the concentration for each of the ions.</li> <li>Using mole ratios from the balanced equation, 1 mole of <math>\text{MnCO}_3(\text{s})</math> ionises to form 1 mole of <math>\text{Mn}^{2+}</math> ions and 1 mole of <math>\text{CO}_3^{2-}</math> ions.</li> <li>You do not know the solubility of <math>\text{MnCO}_3</math>, so give it the value 's' (for solubility in <math>\text{mol L}^{-1}</math>).</li> <li>Therefore, <math>s \text{ mol L}^{-1}</math> of <math>\text{MnCO}_3</math> ionises to form <math>s \text{ mol L}^{-1}</math> of <math>\text{Mn}^{2+}</math> ions and <math>s \text{ mol L}^{-1}</math> of <math>\text{CO}_3^{2-}</math> ions.</li> </ul>
$K_{sp} = [\text{Mn}^{2+}] \times [\text{CO}_3^{2-}]$	<ul style="list-style-type: none"> <li>Write the equilibrium expression.</li> </ul>
$2.24 \times 10^{-11} = [s] \times [s]$ $s^2 = 2.24 \times 10^{-11}$ $s = \sqrt{2.24 \times 10^{-11}}$ $s = 4.73 \times 10^{-6}$	<ul style="list-style-type: none"> <li>Substitute data into the equilibrium expression to calculate 's'.</li> </ul>
$[\text{Mn}^{2+}] = 4.73 \times 10^{-6} \text{ mol L}^{-1}$ $[\text{CO}_3^{2-}] = 4.73 \times 10^{-6} \text{ mol L}^{-1}$	<ul style="list-style-type: none"> <li>Calculate the <math>[\text{Mn}^{2+}]</math> and <math>[\text{CO}_3^{2-}]</math>.</li> </ul>

### WORKED EXAMPLE (4.5B)

The  $K_{sp}$  for calcium iodate  $\text{Ca}(\text{IO}_3)_2$  is  $6.47 \times 10^{-6}$  at  $25^\circ\text{C}$ . Calculate the concentrations of the calcium ions and iodate ions in a saturated aqueous solution of calcium iodate.

ANSWER	LOGIC
$\text{Ca}(\text{IO}_3)_2(\text{s}) \rightleftharpoons \text{Ca}^{2+}(\text{aq}) + 2\text{IO}_3^{-}(\text{aq})$	<ul style="list-style-type: none"> <li>Write the balanced equation for the solubility of the salt.</li> </ul>
$[\text{Ca}^{2+}] = s \text{ mol L}^{-1}$ $[\text{IO}_3^{-}] = 2s \text{ mol L}^{-1}$	<ul style="list-style-type: none"> <li>Determine the concentration for each of the ions.</li> <li>Using mole ratios from the balanced equation, 1 mole of <math>\text{Ca}(\text{IO}_3)_2(\text{s})</math> ionises to form 1 mole of <math>\text{Ca}^{2+}</math> ions and 2 moles of <math>\text{IO}_3^{-}</math> ions.</li> <li>You do not know the solubility of <math>\text{Ca}(\text{IO}_3)_2</math>, so give it the value 's' (for solubility in <math>\text{mol L}^{-1}</math>).</li> <li>Therefore, <math>s \text{ mol L}^{-1}</math> of <math>\text{Ca}(\text{IO}_3)_2</math> ionises to form <math>s \text{ mol L}^{-1}</math> of <math>\text{Ca}^{2+}</math> ions and <math>2s \text{ mol L}^{-1}</math> of <math>\text{IO}_3^{-}</math> ions.</li> </ul>
$K_{sp} = [\text{Ca}^{2+}] \times [\text{IO}_3^{-}]^2$	<ul style="list-style-type: none"> <li>Write the equilibrium expression.</li> </ul>

ANSWER	LOGIC
$6.47 \times 10^{-6} = [s] \times [2s]^2$ $4s^3 = 6.47 \times 10^{-6}$ $s = \sqrt[3]{\frac{6.47 \times 10^{-6}}{4}}$ $s = 0.0117$	<ul style="list-style-type: none"> <li>Substitute data into the equilibrium expression to calculate 's':</li> </ul>
$[\text{Ca}^{2+}] = 0.0117 \text{ mol L}^{-1}$ $[\text{IO}_3^-] = 0.0234 \text{ mol L}^{-1}$	<ul style="list-style-type: none"> <li>Calculate the <math>[\text{Ca}^{2+}]</math> and <math>[\text{IO}_3^-]</math>:           <math display="block">[\text{Ca}^{2+}] = s = 0.0117 \text{ mol L}^{-1}</math> <math display="block">[\text{IO}_3^-] = 2s = 2 \times 0.0117 = 0.0234 \text{ mol L}^{-1}</math> </li> </ul>

### TRY THESE YOURSELF

- The  $K_{sp}$  for silver chloride is  $1.77 \times 10^{-10}$  at  $25^\circ\text{C}$ . Calculate the concentrations of the silver ions and chloride ions in a saturated aqueous solution of silver chloride.
- The  $K_{sp}$  for barium hydroxide is  $2.55 \times 10^{-4}$  at  $25^\circ\text{C}$ . Calculate the concentrations of the barium ions and hydroxide ions in a saturated aqueous solution of barium hydroxide.
- The  $K_{sp}$  for copper(II) phosphate,  $\text{Cu}_3(\text{PO}_4)_2$ , is  $1.40 \times 10^{-37}$  at  $25^\circ\text{C}$ . Calculate the concentrations of the copper ions and phosphate ions in a saturated aqueous solution of copper(II) phosphate.

The  $K_{sp}$  can also be used to determine the solubility of the solute at a specific temperature.

### WORKED EXAMPLE 4.6

The  $K_{sp}$  for calcium iodate,  $\text{Ca}(\text{IO}_3)_2$ , is  $6.47 \times 10^{-6}$  at  $25^\circ\text{C}$ . Calculate the solubility of calcium iodate in g/100 g  $\text{H}_2\text{O}$  at  $25^\circ\text{C}$  and determine whether it would be classified as sparingly soluble or insoluble.



Numeracy



Critical and creative thinking

ANSWER	LOGIC
$\text{Ca}(\text{IO}_3)_2(\text{s}) \rightleftharpoons \text{Ca}^{2+}(\text{aq}) + 2\text{IO}_3^-(\text{aq})$	<ul style="list-style-type: none"> <li>Write the balanced equation for the solubility of the salt.</li> </ul>
$[\text{Ca}^{2+}] = s \text{ mol L}^{-1}$ $[\text{IO}_3^-] = 2s \text{ mol L}^{-1}$	<ul style="list-style-type: none"> <li>Determine the concentration for each of the ions.</li> <li>Using mole ratios from the balanced equation, 1 mole of <math>\text{Ca}(\text{IO}_3)_2(\text{s})</math> ionises to form 1 mole of <math>\text{Ca}^{2+}</math> ions and 2 moles of <math>\text{IO}_3^-</math> ions.</li> <li>You do not know the solubility of <math>\text{Ca}(\text{IO}_3)_2</math>, so give it the value 's' (for solubility in <math>\text{mol L}^{-1}</math>).</li> <li>Therefore, <math>s \text{ mol L}^{-1}</math> of <math>\text{Ca}(\text{IO}_3)_2</math> ionises to form <math>s \text{ mol L}^{-1}</math> of <math>\text{Ca}^{2+}</math> ions and <math>2s \text{ mol L}^{-1}</math> of <math>\text{IO}_3^-</math> ions.</li> </ul>
$K_{sp} = [\text{Ca}^{2+}] \times [\text{IO}_3^-]^2$	<ul style="list-style-type: none"> <li>Write the equilibrium expression.</li> </ul>
$6.47 \times 10^{-6} = [s] \times [2s]^2$ $4s^3 = 6.47 \times 10^{-6}$ $s = \sqrt[3]{\frac{6.47 \times 10^{-6}}{4}}$ $s = 0.0117$	<ul style="list-style-type: none"> <li>Substitute data into equilibrium expression to calculate 's':</li> </ul>



ANSWER	LOGIC
Solubility of $\text{Ca}(\text{IO}_3)_2 = 0.0117 \text{ mol L}^{-1}$	<ul style="list-style-type: none"> <li>Calculate the solubility of <math>\text{Ca}(\text{IO}_3)_2(\text{s})</math>.</li> <li>Since <math>s \text{ mol L}^{-1}</math> of <math>\text{Ca}(\text{IO}_3)_2</math> ionised, therefore the solubility of <math>\text{Ca}(\text{IO}_3)_2</math> is <math>0.0117 \text{ mol L}^{-1}</math>.</li> </ul>
Solubility of $\text{Ca}(\text{IO}_3)_2 = 0.456 \text{ g L}^{-1}$	<ul style="list-style-type: none"> <li>Convert solubility in <math>\text{mol L}^{-1}</math> to <math>\text{g L}^{-1}</math>: <math>m = n \times MM = 0.0117 \times 389.9 = 4.56 \text{ g}</math></li> <li>Solubility of <math>\text{Ca}(\text{IO}_3)_2</math> is <math>4.56 \text{ g L}^{-1}</math>.</li> </ul>
$\text{Ca}(\text{IO}_3)_2$ is sparingly soluble.	<ul style="list-style-type: none"> <li>Determine if <math>\text{Ca}(\text{IO}_3)_2</math> is sparingly soluble or insoluble.</li> <li>Insoluble salts are salts with a solubility of less than <math>1 \text{ g L}^{-1}</math>.</li> <li>Solubility of <math>\text{Ca}(\text{IO}_3)_2</math> is <math>4.56 \text{ g L}^{-1}</math>.</li> <li>Since solubility of <math>\text{Ca}(\text{IO}_3)_2</math> is not less than <math>1 \text{ g L}^{-1}</math>, it is sparingly soluble.</li> </ul>

#### TRY THIS YOURSELF

Determine whether the following salts are classified as sparingly soluble or insoluble at  $25^\circ\text{C}$ .

- a Silver chloride ( $K_{sp} = 1.77 \times 10^{-10}$ )  
b Silver sulfate ( $K_{sp} = 1.20 \times 10^{-5}$ )

### Ionic product

As stated earlier, you can only use the symbol  $K_{sp}$  when there is an equilibrium system; that is, when there is a saturated solution and both solid and ions are present. Equilibrium systems will only occur for 'sparingly soluble' or 'insoluble' salts. However, if there is a very, very dilute solution of a sparingly soluble salt, such as lead(II) bromide, then the concentrations of the ions will be too small to produce any precipitate. In this case, equilibrium will not occur, since there is no solid lead(II) bromide present. Hence, the reaction quotient for this system is called the **ionic product** and is denoted as  $Q_{sp}$ .

- If  $Q_{sp} < K_{sp}$ , the forward reaction will be favoured to reach equilibrium (that is, no precipitate has formed and it is an unsaturated solution).
- If  $Q_{sp} = K_{sp}$ , the reaction has reached dynamic equilibrium (that is, it is a saturated solution).
- If  $Q_{sp} > K_{sp}$ , the reverse reaction will be favoured to reach equilibrium (that is, it is a supersaturated solution).

#### WORKED EXAMPLE 4.7

$0.500 \text{ g}$  of  $\text{Ba}(\text{OH})_2$  was placed into  $200 \text{ mL}$  of water at  $25^\circ\text{C}$  and stirred. Determine whether a precipitate forms.  $K_{sp}$  for  $\text{Ba}(\text{OH})_2$  at  $25^\circ\text{C}$  is  $2.55 \times 10^{-4}$ .



Numeracy



Critical and creative thinking

ANSWER	LOGIC
$\text{Ba}(\text{OH})_2(\text{s}) \rightleftharpoons \text{Ba}^{2+}(\text{aq}) + 2\text{OH}^{-}(\text{aq})$	<ul style="list-style-type: none"> <li>Write the balanced equation for the solubility of the salt.</li> </ul>
$0.500 \times 5 = 2.50 \text{ g L}^{-1}$ $[\text{Ba}(\text{OH})_2] = 0.0146 \text{ mol L}^{-1}$ $n = \frac{m}{MM} = \frac{2.50}{171.3} = 0.0146 \text{ mol L}^{-1}$	<ul style="list-style-type: none"> <li>Calculate <math>[\text{Ba}(\text{OH})_2]</math> in <math>\text{mol L}^{-1}</math>.</li> <li>Convert <math>\text{g}/200 \text{ mL}</math> to <math>\text{g L}^{-1}</math>.</li> <li>Convert <math>\text{g L}^{-1}</math> to <math>\text{mol L}^{-1}</math>.</li> </ul>

ANSWER	LOGIC
$[\text{Ba}^{2+}] = 0.0146 \text{ mol L}^{-1}$ $[\text{OH}^-] = 0.0292 \text{ mol L}^{-1}$	<ul style="list-style-type: none"> <li>Calculate concentrations of each ion.</li> <li>Using mole ratios from the balanced equation, 1 mole of <math>\text{Ba}(\text{OH})_2</math> ionises to form 1 mole of <math>\text{Ba}^{2+}</math> ions and 2 moles of <math>\text{OH}^-</math> ions.</li> <li>Therefore, <math>0.0146 \text{ mol L}^{-1}</math> of <math>\text{Ba}(\text{OH})_2</math> ionises to form <math>0.0146 \text{ mol L}^{-1}</math> of <math>\text{Ba}^{2+}</math> ions and <math>2 \times 0.0146 \text{ mol L}^{-1}</math> (i.e. <math>0.0292 \text{ mol L}^{-1}</math>) of <math>\text{OH}^-</math> ions.</li> </ul>
$Q_{sp} = [\text{Ba}^{2+}] \times [\text{OH}^-]^2$	<ul style="list-style-type: none"> <li>Write the equation for the ionic product.</li> </ul>
$Q_{sp} = [0.0146] \times [0.0292]^2 = 1.24 \times 10^{-5}$	<ul style="list-style-type: none"> <li>Substitute data into the equilibrium expression to calculate <math>Q_{sp}</math>.</li> </ul>
No precipitate formed	<ul style="list-style-type: none"> <li>Compare <math>Q_{sp}</math> with <math>K_{sp}</math>.</li> <li>Since <math>Q_{sp} &lt; K_{sp}</math>, no precipitate has formed; i.e. all of the <math>\text{Ba}(\text{OH})_2</math> dissolved.</li> </ul>

#### TRY THIS YOURSELF

$0.0118 \text{ mol L}^{-1} \text{ Pb}^{2+}$  reacted with  $0.236 \text{ mol L}^{-1} \text{ Br}^-$ . Determine whether a precipitate formed.  $K_{sp}$  for  $\text{PbBr}_2$  at  $25^\circ\text{C}$  is  $6.60 \times 10^{-6}$ .

- When a salt is dissolved in distilled water, there is a direct relationship between the solubility product and the concentration of each of the ions measured in  $\text{mol L}^{-1}$  (this is referred to as the molar solubility).



Solubility equilibrium calculations

- Define the following terms.
  - Molar solubility
  - Insoluble
- Calculate the  $K_{sp}$  for  $\text{Co}(\text{OH})_2$  at  $25^\circ\text{C}$  given that its molar solubility is  $1.14 \times 10^{-5} \text{ mol L}^{-1}$ .
- Calculate the  $[\text{Fe}^{2+}]$  and  $[\text{CO}_3^{2-}]$  in a saturated solution of  $\text{FeCO}_3$  given that it has a  $K_{sp}$  of  $3.13 \times 10^{-11}$  at  $25^\circ\text{C}$ .
  - Calculate the  $[\text{Eu}^{3+}]$  and  $[\text{OH}^-]$  in a saturated solution of  $\text{Eu}(\text{OH})_3$  given that it has a  $K_{sp}$  of  $9.38 \times 10^{-27}$  at  $25^\circ\text{C}$ .
- Justify whether each of the following is sparingly soluble or insoluble.
  - Caesium periodate ( $\text{CsIO}_4$ ), given that its  $K_{sp}$  is  $5.16 \times 10^{-6}$  at  $25^\circ\text{C}$
  - Strontium iodate ( $\text{Sr}(\text{IO}_3)_2$ ), given that its  $K_{sp}$  is  $1.14 \times 10^{-7}$  at  $25^\circ\text{C}$
- $10.0 \text{ g}$  of zinc fluoride was placed into a beaker containing  $500 \text{ mL}$  of water. Justify whether a precipitate forms. The  $K_{sp}$  for zinc fluoride is  $0.0304$  at  $25^\circ\text{C}$ .

#### CHECK YOUR UNDERSTANDING

4.7



Numeracy

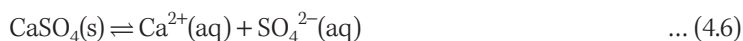


Critical and creative thinking

## 4.8 The common ion effect

So far, we've looked at equilibrium where there is a single ionic salt present in the solution. Here, we'll look at what happens when another chemical, which has an ion in common with the original ionic salt, is added to the solution (for example, adding  $\text{Na}_2\text{SO}_4$  to a test tube that has some  $\text{CaSO}_4$  in it). The  $\text{CaSO}_4$  is sparingly soluble in water.

Let us use Le Chatelier's principle to determine the effect of adding  $\text{Na}_2\text{SO}_4$  to a test tube that has some  $\text{CaSO}_4$  in it:



$\text{Na}_2\text{SO}_4$  is a soluble salt, and it will completely dissociate to form  $\text{Na}^+$  and  $\text{SO}_4^{2-}$ . Therefore, when  $\text{Na}_2\text{SO}_4$  is added to the test tube containing the  $\text{CaSO}_4$ , there is an increase in the concentration of  $\text{SO}_4^{2-}$ . According to Le Chatelier's principle, the chemical system represented in equation 4.6 will adjust to overcome this increase in the concentration of  $\text{SO}_4^{2-}$ , and hence, it will favour the reverse reaction. This will cause a decrease in the concentration of  $\text{Ca}^{2+}$  and an increase in the mass of  $\text{CaSO}_4$  that has precipitated. Thus, the sparingly soluble salt is even less soluble when there is a common ion present.

This example illustrates that adding a common ion to a saturated solution will decrease the solubility of the salt. This is known as the **common ion effect**.

Now, we'll use quantitative data to analyse this example.

The  $K_{sp}$  for calcium sulfate at  $25^\circ\text{C}$  is  $4.93 \times 10^{-5}$ .

The equilibrium expression for equation 4.6 is:

$$K_{sp} = [\text{Ca}^{2+}] \times [\text{SO}_4^{2-}] \quad \dots (4.7)$$

At equilibrium:

$$[\text{Ca}^{2+}] = [\text{SO}_4^{2-}] = s$$

Therefore,

$$K_{sp} = 4.93 \times 10^{-5} = s^2$$

and

$$s = \sqrt{4.93 \times 10^{-5}} = 7.02 \times 10^{-3}$$

Hence, a saturated solution of calcium sulfate in water contains a  $\text{Ca}^{2+}$  concentration of  $7.02 \times 10^{-3} \text{ mol L}^{-1}$ .

Let us see what happens when calcium sulfate is dissolved in a solution containing  $0.100 \text{ mol L}^{-1}$   $\text{Na}_2\text{SO}_4$ . **Note:**  $[\text{SO}_4^{2-}] = [\text{Na}_2\text{SO}_4]$  since  $\text{Na}_2\text{SO}_4$  completely dissociates and there is a 1:1 ratio between  $\text{Na}_2\text{SO}_4$  and  $\text{SO}_4^{2-}$ .

$[\text{Ca}^{2+}] = s$  due to dissociation of  $\text{CaSO}_4$ .

$[\text{SO}_4^{2-}] = (0.100 + s)$  due to dissociation of  $\text{Na}_2\text{SO}_4$  and the dissociation of  $\text{CaSO}_4$ .

However, since  $\text{Na}_2\text{SO}_4$  completely dissociates and  $\text{CaSO}_4$  only sparingly dissociates, then  $s \ll 0.100 \text{ mol L}^{-1}$  and therefore:

$$(0.100 + s) \approx 0.100 \quad \dots (4.8)$$

Substituting into the equilibrium expression denoted by equation 4.7

$$K_{sp} = 4.93 \times 10^{-5} = s \times 0.100$$

$$s = \frac{4.93 \times 10^{-5}}{0.100} = 4.93 \times 10^{-4} \quad \dots (4.9)$$

Hence,  $[\text{Ca}^{2+}] = 4.93 \times 10^{-4} \text{ mol L}^{-1}$  when  $\text{CaSO}_4$  dissolves in  $0.100 \text{ mol L}^{-1}$   $\text{Na}_2\text{SO}_4$  solution. This is less than the  $[\text{Ca}^{2+}]$  when it was dissolved in water. Therefore,  $\text{CaSO}_4$  is less soluble in a  $\text{Na}_2\text{SO}_4$  solution than it is in water. This supports the qualitative effect determined using Le Chatelier's principle.

Also, note that in equation 4.9,  $s = 4.93 \times 10^{-4}$ , which is significantly less than 0.100. Hence, the assumption made in equation 4.8 is valid.

## WORKED EXAMPLE (4.8)



Compare, both qualitatively and quantitatively, the solubility of silver iodide in water with its solubility in  $0.250 \text{ mol L}^{-1}$  KI.  $K_{sp}$  for silver iodide is  $8.52 \times 10^{-17}$  at  $25^\circ\text{C}$ .

ANSWER	LOGIC
$\text{AgI(s)} \rightleftharpoons \text{Ag}^+(\text{aq}) + \text{I}^-(\text{aq})$	<ul style="list-style-type: none"> <li>Write the balanced equation for the solubility of the salt.</li> </ul>
<p>Solubility of AgI decreases when it is dissolved in KI solution.</p>	<ul style="list-style-type: none"> <li>Use Le Chatelier's principle to determine the effect of increasing the <math>[\text{I}^-]</math>.</li> <li>When the <math>[\text{I}^-]</math> is increased, according to Le Chatelier's principle, the system will adjust to minimise this change by favouring the reverse equation. Hence, increasing the precipitation of AgI. Therefore, the solubility of AgI decreases.</li> </ul>
$K_{sp} = [\text{Ag}^+] \times [\text{I}^-]$	<ul style="list-style-type: none"> <li>Write the equilibrium expression.</li> </ul>
$[\text{Ag}^+] = [\text{I}^-] = s$ <p>Therefore:</p> $K_{sp} = 8.52 \times 10^{-17} = s^2$ $s = \sqrt{8.52 \times 10^{-17}} = 9.23 \times 10^{-9}$ <p>Solubility of <math>\text{Ag}^+</math> in water is <math>9.23 \times 10^{-9} \text{ mol L}^{-1}</math>.</p>	<ul style="list-style-type: none"> <li>Calculate the solubility of <math>\text{Ag}^+</math> in water.</li> </ul>
<p><math>[\text{I}^-] = [\text{KI}]</math> since KI completely dissociates and there is a 1:1 ratio between KI and <math>\text{I}^-</math>.</p> <p><math>[\text{Ag}^+] = s</math> due to the dissociation of AgI</p> <p><math>[\text{I}^-] = (0.250 + s)</math> due to the dissociation of KI and the dissociation of AgI</p> <p>Since <math>s \ll 0.250</math></p> <p>Therefore, <math>(0.250 + s) \approx 0.250</math></p> <p>Substituting into the equilibrium expression:</p> $K_{sp} = 8.52 \times 10^{-17} = s \times 0.250$ $s = \frac{8.52 \times 10^{-17}}{0.250} = 3.41 \times 10^{-16}$ <p>Solubility of <math>\text{Ag}^+</math> in <math>0.250 \text{ mol L}^{-1}</math> KI is <math>3.41 \times 10^{-16} \text{ mol L}^{-1}</math>.</p>	<ul style="list-style-type: none"> <li>Calculate the solubility of <math>\text{Ag}^+</math> in <math>0.250 \text{ mol L}^{-1}</math> KI.</li> </ul>
<p>Solubility of <math>\text{Ag}^+</math> in water is <math>9.23 \times 10^{-9} \text{ mol L}^{-1}</math>.</p> <p>While the solubility of <math>\text{Ag}^+</math> in <math>0.250 \text{ mol L}^{-1}</math> KI is <math>3.41 \times 10^{-16} \text{ mol L}^{-1}</math>:</p> $\frac{9.23 \times 10^{-9}}{3.41 \times 10^{-16}} = 27 \times 10^6$ <p>Hence, solubility of AgI is about 27 million times less in <math>0.250 \text{ mol L}^{-1}</math> KI compared to its solubility in water.</p>	<ul style="list-style-type: none"> <li>Compare the values for the solubility of <math>\text{Ag}^+</math> in water and <math>0.250 \text{ mol L}^{-1}</math> KI.</li> </ul>

### TRY THESE YOURSELF

- Quantitatively compare the solubility of magnesium carbonate in  $0.550 \text{ mol L}^{-1}$   $\text{Na}_2\text{CO}_3$  with its solubility in  $0.375 \text{ mol L}^{-1}$   $\text{Na}_2\text{CO}_3$ .  $K_{sp}$  for  $\text{MgCO}_3$  is  $6.82 \times 10^{-12}$  at  $25^\circ\text{C}$ .
- Qualitatively and quantitatively compare the solubility of  $\text{Cu}(\text{OH})_2$  in water and  $0.075 \text{ mol L}^{-1}$  NaOH.  $K_{sp}$  for  $\text{Cu}(\text{OH})_2$  is  $2.2 \times 10^{-20}$  at  $25^\circ\text{C}$ .

## INVESTIGATION 4.5

### Teacher demonstration: Common ion effect

#### AIM

To observe the common ion effect.

#### MATERIALS

- 6 mL saturated NaCl solution
- Dropper bottle concentrated HCl
- Dropper bottle  $10\text{ mol L}^{-1}$  NaOH
- 3 test tubes
- Test-tube rack
- 3 small labels
- Measuring cylinder (5 mL) or disposable droppers
- Safety glasses



WHAT ARE THE RISKS IN DOING THIS INVESTIGATION?	HOW CAN YOU MANAGE THESE RISKS TO STAY SAFE?
Concentrated HCl is highly corrosive.	Use in a fume cupboard or open windows and turn on fans to create a well-ventilated space. Teacher to use a dropper to dispense HCl. Wear safety glasses and wash hands immediately after use.
$10\text{ mol L}^{-1}$ NaOH is very corrosive.	Wear safety glasses to protect eyes from splashes. Teacher to use a dropper to dispense NaOH. Wash hands immediately after use.

What other risks are associated with your investigation? How can you manage these?

#### METHOD

- 1 Label test tubes A, B and C.
- 2 Pour 2 mL of the saturated NaCl solution into three test tubes.
- 3 Add 10 drops of concentrated HCl to test tube B and record observations using words or photos.
- 4 Add 10 drops of  $10\text{ mol L}^{-1}$  NaOH to test tube C and record observations using words or photos.

#### RESULTS

Record your observations in a carefully planned table.

#### CONCLUSION

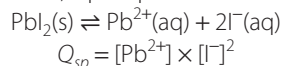
- 1 What was the purpose of test tube A?
- 2 Justify how this investigation illustrates the common ion effect.

## INVESTIGATION 4.6

### Determining the $K_{sp}$ for lead(II) iodide

#### INTRODUCTION

A variety of mixtures of known concentrations of  $Pb^{2+}$  and  $I^-$  will be prepared. In some cases, the ionic product ( $Q_{sp}$ ) will exceed the solubility product ( $K_{sp}$ ) and a precipitate of  $PbI_2$  will form, while in others, the ionic product will not exceed the solubility product, and hence, a precipitate will not form.



The  $K_{sp}$  for  $PbI_2$  will not be able to be measured directly. However, you will be able to determine it indirectly.

To avoid local supersaturation, always add the water to the test tube first. This investigation can be done in groups or can be done collaboratively as a class. Stock solutions must be prepared using deionised water.

#### AIM

To determine the  $K_{sp}$  for  $PbI_2$ .

#### MATERIALS

- Burette containing  $1.00 \times 10^{-2} \text{ mol L}^{-1} Pb(NO_3)_2$
- Burette containing  $1.00 \times 10^{-2} \text{ mol L}^{-1} KI$
- Burette containing deionised water
- 9 large test tubes
- Test-tube rack
- 9 small labels
- Heavy metal waste bottle
- Retort stands
- Burette clamps
- Safety glasses

Complete a risk assessment for your investigation.

WHAT ARE THE RISKS IN DOING THIS INVESTIGATION?	HOW CAN YOU MANAGE THESE RISKS TO STAY SAFE?
Lead salts are highly toxic.	Use a burette to dispense lead salts. Wear safety glasses and wash hands immediately after use. Dispose of solutions in the heavy metal waste bottle provided.



What other risks are associated with your investigation? How can you manage these?

#### METHOD

- 1 Label each of the test tubes 1–9.
- 2 Make up each of the mixtures given in the table in separate test tubes. Remember to put the water in the test tube first.
- 3 Leave each mixture for at least 30 minutes before observing if a precipitate has formed.

TEST TUBE	VOL H <sub>2</sub> O (mL)	VOL Pb <sup>2+</sup> (mL)	VOL I <sup>-</sup> (mL)	[Pb <sup>2+</sup> ]	[I <sup>-</sup> ]	$Q_{sp}$	PbI <sub>2</sub> FORMED
1	1.00	4.00	5.00				
2	2.00	3.00	5.00				
3	3.00	2.00	5.00				
4	4.00	1.00	5.00				
5	5.50	2.50	2.00				
6	6.30	1.20	2.50				
7	6.75	1.25	2.00				
8	6.50	2.50	1.00				
9	8.00	1.00	1.00				





## » RESULTS

After at least 30 minutes, record whether a precipitate formed.

### ANALYSIS OF RESULTS

- 1 Use the following equation to determine the concentration of each of the ions in the mixture:

$$[\text{ion}]_{\text{mixture}} = [\text{ion}]_{\text{stock solution}} \times \frac{\text{Volume (mL) of ion added to solution}}{\text{Total volume (mL) of solution}}$$

- 2 Use these values to determine the  $Q_{sp}$  for each mixture (1–9).
- 3 Identify the smallest value for  $Q_{sp}$  that has a precipitate present.
- 4 Identify the largest value for  $Q_{sp}$  that does not have a precipitate present.
- 5 Determine the range for the  $K_{sp}$  for  $\text{PbI}_2$  – it lies between the values found in **3** and **4**.

### CONCLUSION

- 1 Compare your value for the  $K_{sp}$  for  $\text{PbI}_2$  and compare it to the value on the NESAs data sheet.
- 2 Discuss reasons for any difference in the  $K_{sp}$  for  $\text{PbI}_2$  between the value obtained in this investigation with the value provided on the NESAs data sheet.

- The common ion effect is when a common ion is added to a saturated solution that decreases the solubility of the salt.

## CHECK YOUR UNDERSTANDING

4.8



Numeracy



Critical and creative thinking

- 1 Define the 'common ion effect'.
- 2 Calculate the solubility of lead(II) bromide in  $0.10 \text{ mol L}^{-1}$  lead(II) nitrate at  $25^\circ\text{C}$ , given that the  $K_{sp}$  for lead(II) bromide is  $6.60 \times 10^{-6}$ .
- 3 Use Le Chatelier's principle to justify whether the solubility of nickel(II) carbonate is greater in  $0.1 \text{ mol L}^{-1}$  nickel(II) nitrate or in water.
- 4 Quantitatively compare the solubility of magnesium hydroxide in water with its solubility in  $0.20 \text{ mol L}^{-1}$  sodium hydroxide. The  $K_{sp}$  for magnesium hydroxide is  $5.61 \times 10^{-12}$  at  $25^\circ\text{C}$ .
- 5 By what factor is the solubility of calcium phosphate decreased when it is placed in  $0.30 \text{ mol L}^{-1}$  sodium phosphate compared to its solubility in  $0.15 \text{ mol L}^{-1}$  sodium phosphate? The  $K_{sp}$  for calcium phosphate at  $25^\circ\text{C}$  is  $2.07 \times 10^{-29}$ .

# 4 CHAPTER SUMMARY

## IMPORTANT NEW TERMS

After studying this chapter you should know the meaning of the following terms:

anhydrous (p. 84)

aqueous solution (p. 94)

common ion effect (p. 108)

complete ionic equation (p. 95)

hydrogen bonding (p. 83)

ion–dipole bond (p. 83)

ionic product (p. 106)

leaching (p. 92)

ligand (p. 84)

molar solubility (p. 102)

net ionic equation (p. 95)

precipitate (p. 94)

precipitation reaction (p. 94)

saturated solution (p. 87)

solubility (p. 87)

solubility curve (p. 87)

solubility product (p. 100)

spectator ions (p. 95)

supersaturated solution (p. 87)

toxin (p. 91)

unpalatable substance (p. 91)

unsaturated solution (p. 87)

VSEPR theory (p. 84)

## AFTER STUDYING THIS CHAPTER YOU SHOULD KNOW:

- ▶ the definitions for all terms in the important new terms list
- ▶ how to describe the structure of ionic compounds and the structure of water
- ▶ why some ionic compounds contain water of crystallisation and others do not
- ▶ how to describe the solubility of ionic compounds in terms of ion–dipole interactions
- ▶ how to explain why an understanding of solubility is used to detoxify some plants
- ▶ how to describe the leaching process
- ▶ how to describe precipitation reactions
- ▶ how to distinguish between ionic product and solubility product
- ▶ how to describe the common ion effect.

## YOU SHOULD BE ABLE TO:

- ▶ interpret solubility curves
- ▶ write net ionic equations
- ▶ identify the precipitate formed when two solutions are mixed
- ▶ use a solubility table to determine whether a solute will produce an aqueous solution
- ▶ write equilibrium expressions for saturated solutions
- ▶ perform calculations involving solubilities and solubility products
- ▶ relate solubility to the solubility product
- ▶ perform calculations to show the common ion effect.

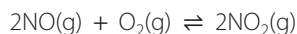


- Define the following terms.
  - Saturated solution
  - Toxin
  - Molar solubility
  - Sparingly soluble
- Distinguish between ionic product and solubility product.
- The solubility of ionic salts increases linearly as the temperature increases. Evaluate this statement with reference to Figure 4.8 (page 87).
- Explain the process of leaching.
- Assess the usefulness of leaching for Australia's first peoples.
- Determine whether a precipitate is formed when the following solutions are mixed. Write a net ionic equation for any precipitate that forms.
  - Sodium chloride and lead nitrate
  - Magnesium sulfate and zinc chloride
  - Barium hydroxide and sodium sulfate
  - Aluminum chloride and ammonium sulfite
  - Copper(II) bromide and sodium carbonate
- When a potassium hydroxide solution was mixed with a magnesium nitrate solution, a magnesium hydroxide precipitate formed.
  - Write a net ionic equation for this chemical reaction.
  - Write the expression for the solubility product for magnesium hydroxide.

In a particular investigation, the concentration of magnesium ions at equilibrium is  $0.00100 \text{ mol L}^{-1}$  and the concentration of hydroxide ions is  $3.74 \times 10^{-5} \text{ mol L}^{-1}$ .
  - Calculate the solubility product of magnesium hydroxide.
  - Calculate the molar solubility of magnesium hydroxide.
- Justify whether a saturated solution of iron(II) hydroxide or iron(III) hydroxide has a greater concentration of iron ions present at  $25^\circ\text{C}$ .
  - $K_{sp}$  for iron(II) hydroxide =  $4.87 \times 10^{-17}$
  - $K_{sp}$  for iron(III) hydroxide =  $2.79 \times 10^{-39}$
- The solubility of silver sulfate is  $14.1 \text{ g L}^{-1}$  at  $100^\circ\text{C}$  and  $5.7 \text{ g L}^{-1}$  at  $10^\circ\text{C}$ .
  - Use Le Chatelier's principle to determine whether the heat of solution for silver sulfate would be endothermic or exothermic.
  - Write the expression for the solubility product for silver sulfate.
  - Calculate the molar solubility for silver sulfate at  $100^\circ\text{C}$ .
  - Calculate the solubility product for silver sulfate at  $100^\circ\text{C}$ .
- The solubility of manganese carbonate is  $0.0065 \text{ g}/100 \text{ g H}_2\text{O}$  at  $25^\circ\text{C}$ . Calculate the  $K_{sp}$  for manganese carbonate.
- The yellow solid, silver chromate ( $\text{Ag}_2\text{CrO}_4$ ), dissolves in water to produce a saturated solution that contains  $0.0025 \text{ g L}^{-1}$  silver chromate.
  - Calculate the molar solubility of silver chromate.
  - Calculate the  $K_{sp}$  for silver chromate.
  - Calculate the molar solubility of silver chromate when  $0.0025 \text{ g L}^{-1}$  is dissolved in  $0.10 \text{ mol L}^{-1}$  silver nitrate.
  - Justify the difference in the value for the molar solubility of silver chromate in parts a and c.

Answer the following questions.

- 1 Nitric oxide reacts with oxygen to form nitrogen dioxide:



The following table gives the equilibrium constant for this reaction at different temperatures.



Numeracy



Literacy

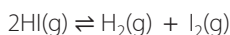


Critical and creative thinking

TEMPERATURE (°C)	EQUILIBRIUM CONSTANT
477	112
727	1.60
1227	$2.4 \times 10^{-2}$
1727	$6.4 \times 10^{-4}$

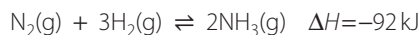
- Write the equilibrium expression for this reaction.
- Justify whether the formation of nitrogen dioxide is endothermic or exothermic.
- Justify the conditions required to maximise the production of nitrogen dioxide.
- The mixture of gases is at equilibrium at 477°C. There is  $0.17 \text{ mol L}^{-1}$  oxygen and  $0.60 \text{ mol L}^{-1}$  nitrogen dioxide. Calculate the concentration of nitric oxide in this mixture.

- 2 Hydrogen iodide decomposes to form hydrogen and iodine at a specific temperature:



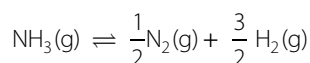
Initially, only 1.00 mol of hydrogen iodide was present in the 1 L container. At equilibrium, there is 0.78 mol of HI remaining.

- Complete the ICE table for this reaction.
  - Calculate the equilibrium constant for the decomposition of hydrogen iodide at this specific temperature.
- 3 Ammonia is produced from nitrogen and hydrogen in the Haber process:



The equilibrium constant in terms of concentration for the Haber process at 300°C is 9.60.

- Explain the effect on the production of ammonia if the temperature was increased.
- Determine  $K_c$  for the following reaction at 300°C:

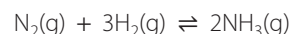


- 4 The production of sulfuric acid involves a number of steps, one of which is the gaseous equilibrium reaction between sulfur dioxide and oxygen to form sulfur trioxide.

A scaled-down version of the reaction was performed in a 3 L container. Initially, 0.18 mol of sulfur dioxide was added to 0.15 mol of oxygen. After equilibrium was reached, the concentration of sulfur trioxide was 0.12 mol.

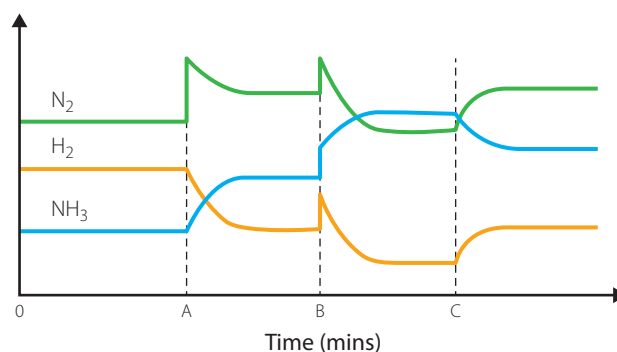
Calculate the equilibrium constant for the reaction.

- 5 Ammonia is produced from nitrogen and hydrogen in the Haber process:



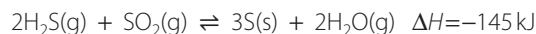
The graph below shows the variations in the concentrations of each species over time.

At time C, the temperature was increased.

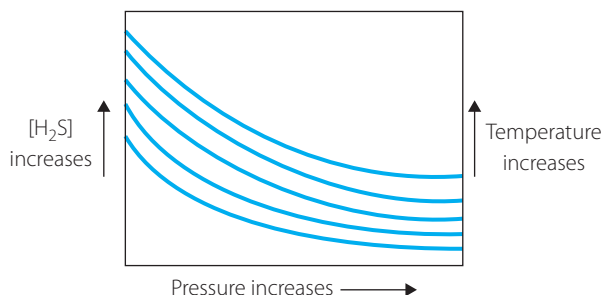


Explain the changes that occur to the system at times A, B and C and justify whether the production of ammonia is an endothermic or exothermic reaction.

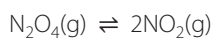
- 6 The removal of hydrogen sulfide from methane is achieved via the following process:



Evaluate whether the figure below is a reasonable representation of the effect of changes in temperature and pressure on the concentration of hydrogen sulfide.



- 7 The decomposition of dinitrogen tetroxide is endothermic:

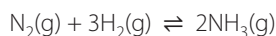


Explain the effect on the equilibrium constant if the:

- a volume of the container is halved
- b temperature of the system is doubled.

- 8 Compare, both qualitatively and quantitatively, the solubility of silver oxalate ( $\text{Ag}_2\text{C}_2\text{O}_4$ ) in water with its solubility in  $0.150 \text{ mol L}^{-1} \text{ AgNO}_3$ .  $K_{sp}$  for silver oxalate is  $5.40 \times 10^{-12}$  at  $25^\circ\text{C}$ .

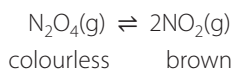
- 9 Nitrogen and hydrogen are mixed to form ammonia according to:



A magnetite catalyst is added to the mixture. Which of the following best describes the effect?

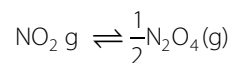
	EQUILIBRIUM YIELD	REACTION RATE
A	Increases	Increases
B	Increases	No change
C	No change	No change
D	No change	Increases

- 10 Dinitrogen tetroxide exists in equilibrium with nitrogen dioxide. A spectrophotometer can be used to determine the  $[\text{NO}_2]$  present in the gaseous mixture.



The equilibrium constant for this reaction is  $4.7 \times 10^{-3}$  at  $298 \text{ K}$ .

- a Write the equation for the equilibrium expression for this reaction.
- b Keeping the volume of the reaction vessel constant, the temperature of the system was then increased by  $20^\circ\text{C}$ . The reaction mixture became a deeper brown. Justify whether the reaction is endothermic or exothermic.
- c Keeping the temperature of the system constant, the volume of the reaction vessel was halved. The system was adjusted to re-establish equilibrium. Justify the effect on the colour of the gaseous mixture in the reaction vessel.
- d Calculate the equilibrium constant for the reaction:



- 11 The equilibrium constant for the decomposition of ethanol to form dimethyl ether and water is  $5.74$  at  $350^\circ\text{C}$ .



Initially, methanol is pumped into a  $15.0 \text{ L}$  reaction vessel. At equilibrium, there is  $0.255 \text{ mol}$  of methanol at  $350^\circ\text{C}$ .

- a Calculate the number of moles of dimethyl ether present at equilibrium.
- b How many moles of methanol were initially pumped into the reaction vessel?

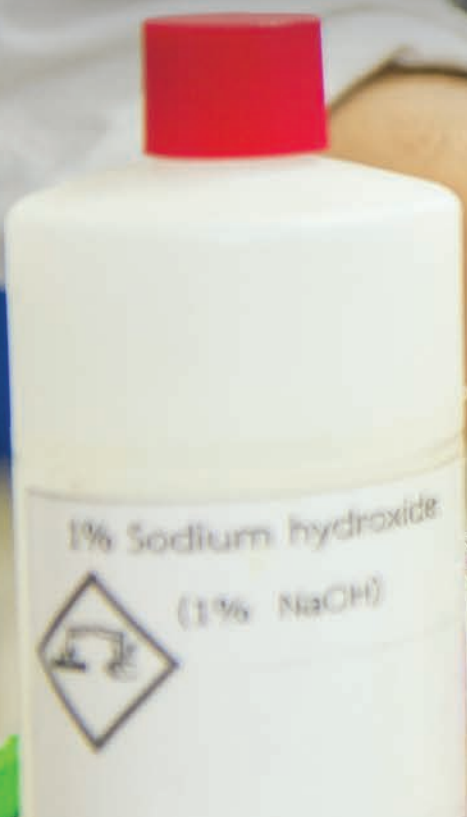
### DEPTH STUDY SUGGESTIONS

- Create a model to demonstrate steady state, dynamic equilibrium and static equilibrium.
- Research how Australia's first peoples removed toxins from foods other than cycads.
- Investigate the solubility of ionic compounds.
- Model collision theory for an equilibrium reaction.
- Use colourimetry to compare the solubility of copper or nickel salts.
- Create an animation to model the common ion effect.

## » MODULE SIX

# ACID/BASE REACTIONS

- 5 Properties of acids and bases
- 6 Using Brønsted–Lowry theory
- 7 Using quantitative analysis





# 5 Properties of acids and bases

## INQUIRY QUESTION

What is an acid and what is a base?

### Students:

investigate the correct IUPAC nomenclature and properties of common inorganic acids and bases (ACSC067)

conduct an investigation to demonstrate the preparation and use of indicators as illustrators of the characteristics and properties of acids and bases and their reversible reactions (ACSC10)

predict the products of acid reactions and write balanced equations to represent: ICT

- acids and bases
- acids and carbonates
- acids and metals (ACSC067)

investigate applications of neutralisation reactions in everyday life and industrial processes

conduct a practical investigation to measure the enthalpy of neutralisation (ACSC09)

explore the changes in definitions and models of an acid and a base over time to explain the limitations of each model, including but not limited to:

- Arrhenis' theory
- Brønsted–Lowry theory. (ACSC06, ACSC67) ICT

Chemistry Stage 6 Syllabus © NSW Educational Standard Authority for and on behalf of the Crown in right of the State of New South Wales, 2017





Our environment is naturally acidic. Rain is slightly acidic, as are many of the foods we eat and drink. Soft drink contains carbonic acid, citrus fruits contain citric acid and vitamin C is also known as ascorbic acid. **Acids** are also important components of many of the compounds that make up living things. Proteins are long chains of amino acids and our stomach produces hydrochloric acid to aid with digestion of food.

**Bases** are also part of our natural environment although not as commonly recognised. Ammonia is a base found in volcanic gases and produced by rotting plant and animal matter. Caffeine, found in coffee and tea, is a base, as is nicotine, which is in tobacco.

As you learnt in Year 11, acids and bases are also important substances in our homes and industry. Figure 5.1 (left) shows some common substances containing acids, while Figure 5.1 (right) shows some common substances containing bases.



**FIGURE 5.1** Some substances from around the home that are acidic (left) and basic (right).



Prior knowledge

## 5.1 Naming inorganic compounds

In *Chemistry in Focus Year 11*, you learnt rules for determining the name and formula of ionic (section 5.4) and molecular compounds (section 5.9). The organisation responsible for developing these rules is the International Union of Pure and Applied Chemistry (IUPAC). The use of an agreed chemical **nomenclature** system is important since it provides a key tool for communication in the chemical sciences.

IUPAC has developed rules for naming inorganic compounds that can be found in the publication *Nomenclature of Inorganic Chemistry*, colloquially known as the Red Book. Rules for naming organic compounds can be found in the Blue Book, while those for naming polymers are in the Purple Book. You will learn about naming organic compounds and polymers in later chapters.

While the Red Book focuses on naming inorganic compounds, molecules and ions (that is, those that do not contain carbon), there is some blurring of boundaries, primarily for those compounds that contain a carbonate ( $\text{CO}_3^{2-}$ ), hydrogen carbonate ( $\text{HCO}_3^-$ ) or cyanide ( $\text{CN}^-$ ) ion.

It should be noted that IUPAC rules allow for more than one systematic name depending on the information required. There are also many compounds that are still known by their common, non-systematic names and these names are also acceptable.

The naming rules you learnt in Year 11 are related to stoichiometric or compositional naming. This type of naming provides information on the composition of an ion, molecule or compound and may be related to either the empirical or molecular formula but it does not provide any structural information.

## Naming inorganic acids

You may remember learning about the common acids: hydrochloric acid (HCl); sulfuric acid (H<sub>2</sub>SO<sub>4</sub>); nitric acid (HNO<sub>3</sub>); and phosphoric acid (H<sub>3</sub>PO<sub>4</sub>) in *Chemistry in Focus Year 11* (section 10.7). These are examples of inorganic acids, also known as mineral acids.

You will learn the rules for the systematic naming of organic acids in chapter 9.

There are also organic acids. These are organic compounds that have acidic properties. The most common organic acids typically have a –COOH group attached at the end of a carbon chain. Examples of common organic acids are citric acid (in citrus fruit), acetic acid in vinegar, lactic acid in milk and ascorbic acid, which is vitamin C.

The term 'acid' is not used consistently in naming substances since there are many species that exhibit the chemical properties of acids (for example, ammonium ion (NH<sub>4</sub><sup>+</sup>)) but are not named as such. As a result, the use of the word 'acid' in any new name in inorganic nomenclature is discouraged. However, non-systematic and semi-systematic acid names of common acids, such as those above, are so commonly used that IUPAC considers these names acceptable.

There are simple rules for determining the nomenclature of common acids that have the general formula HA. The compositional name of an inorganic acid is derived from the anion (A) that is formed when the acid, HA, dissociates in water to form H<sup>+</sup> and A<sup>-</sup>. The anion may be monoatomic (for example, Cl<sup>-</sup>) or polyatomic (for example, SO<sub>4</sub><sup>2-</sup>). There is one exception to this, which is acetic acid (CH<sub>3</sub>COOH). This is a common organic acid so its formula is generally written using organic nomenclature conventions. You may also see the formula written HC<sub>2</sub>H<sub>3</sub>O<sub>2</sub>, which is the inorganic style.

Most acids are what are called **oxyacids**: they have oxygen attached to an element such as sulfur, nitrogen, phosphorus or carbon. It is important to know the correct name of the anion when naming the acid from which it is produced. Refer to appendix 4 for the names of common ions.

The flow chart in Figure 5.2 summarises the steps used for naming common inorganic acids.

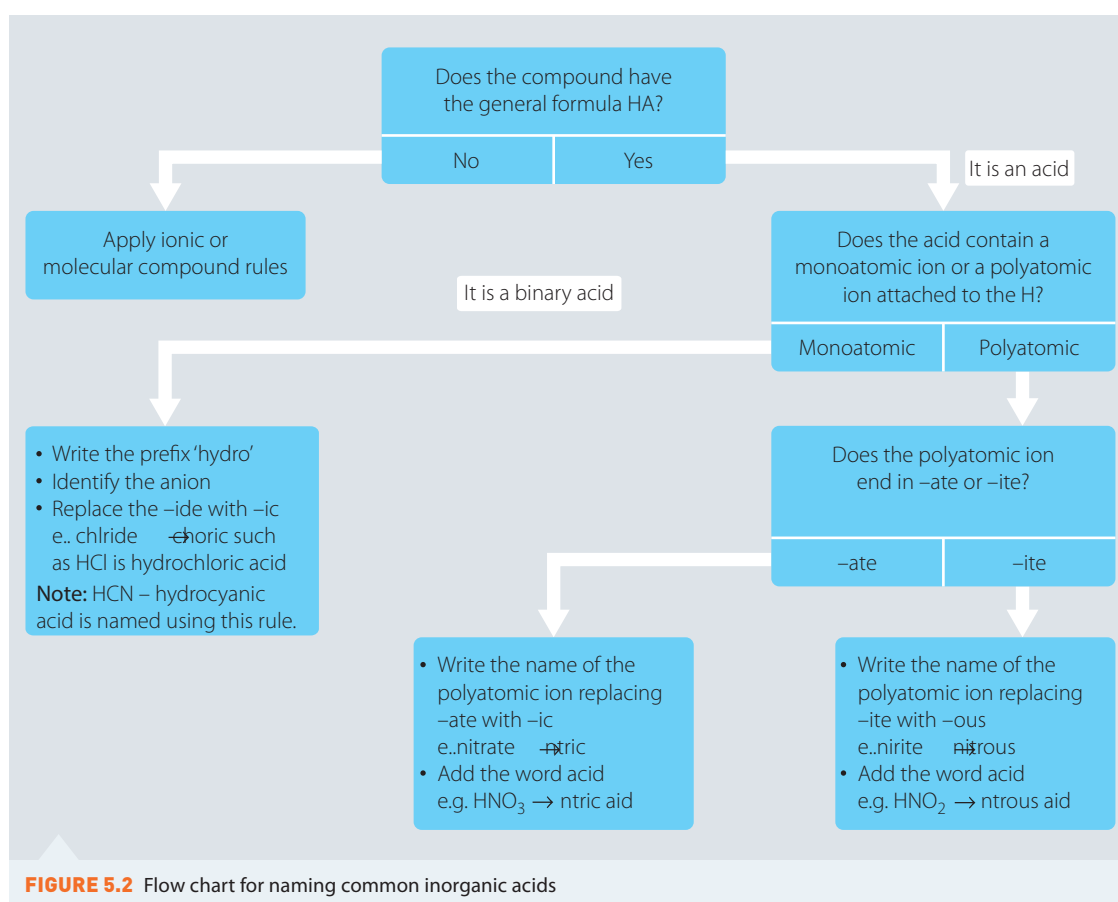


FIGURE 5.2 Flow chart for naming common inorganic acids

## Naming inorganic bases

You may remember learning about the common bases: sodium hydroxide (NaOH); barium hydroxide ( $\text{Ba}(\text{OH})_2$ ); magnesium oxide (MgO); iron(III) oxide ( $\text{Fe}_2\text{O}_3$ ); copper(II) hydroxide ( $\text{Cu}(\text{OH})_2$ ); and ammonia ( $\text{NH}_3$ ) (which in aqueous solution produces  $\text{NH}_4^+$  and  $\text{OH}^-$  ions) in *Chemistry in Focus Year 11* (section 10.7). These are examples of inorganic bases.

As you learnt in *Chemistry in Focus Year 11*, bases that are soluble in water are called **alkalis**. Common alkalis are sodium and potassium hydroxides, calcium and barium hydroxides, and ammonia. There are also organic bases, organic compounds with certain basic properties. The most common organic bases contain a nitrogen atom bonded to carbon groups. One important class is known as amines. Those with a  $-\text{NH}_2$  group attached to the end of a carbon chain are called primary amines. Examples of organic bases include quinine, caffeine, strychnine, nicotine and morphine.

In *Chemistry in Focus Year 11* a base was defined as a substance that contains either the hydroxide ( $\text{OH}^-$ ) or the oxide ( $\text{O}^{2-}$ ) ion or which in solution produces the hydroxide ion. Metallic oxides and hydroxides are ionic compounds that contain the oxide or hydroxide ion respectively and so are bases. Therefore, these bases are named using the rules for naming ionic compounds.

Weak bases may be ionic, molecular or organic compounds. Therefore, they are named using the relevant naming rules for each of those classifications.

You will learn more about amines in chapter 9.

### CHECK YOUR UNDERSTANDING

5.1

- Name the following acids.
  - HF
  - $\text{H}_2\text{SO}_4$
  - $\text{H}_2\text{CO}_3$
- Write the formula for the following acids.
  - Hydrobromic acid
  - Hydrocyanic acid
  - Nitric acid
- Name the following bases.
  - KOH
  - $\text{Ca}(\text{OH})_2$
  - $\text{Fe}_2\text{O}_3$
- Write the formula for the following bases.
  - Lithium hydroxide
  - Cobalt(II) hydroxide
  - Magnesium oxide
- Acids may be named using the IUPAC systematic name. For example, the systematic name for sulfurous acid ( $\text{H}_2\text{SO}_3$ ) is dihydroxidooxidosulfur.
  - Match up the components of the name with parts of the acid formula. (**Hint:** Rewriting the formula as  $\text{SO}(\text{OH})_2$  will help.)
  - Which of the following substances would be named dihydroxidodioxidosulfur?
    - HCl
    - $\text{HSO}_4^-$
    - $\text{H}_2\text{SO}_4$
    - $\text{H}_2\text{S}$





**FIGURE 5.3** *Pamelia sulcata* is used as a source of dye for litmus.

## 5.2

# Properties of common inorganic acids and bases

Acids and bases are families of substances, and members of these families can be recognised and defined by their common properties.

Common properties of acids include:

- ▶ a sour taste (note that students must never taste chemicals in the laboratory)
- ▶ conducting electricity in solution
- ▶ turning blue litmus (a vegetable dye) red. (**B**lue in **A**cid goes **R**ed – **BAR**)

Common properties of bases include:

- ▶ a soapy feel in aqueous solution
- ▶ a bitter taste (though, again students should never taste them)
- ▶ conducting electricity in solution (though not all bases are soluble)
- ▶ turning red litmus blue (the opposite of acids).

It was the effects of acids and bases on vegetable dyes such as litmus that was initially used to help classify substances as acids and bases. Litmus can be found and extracted from different species of lichens such as *Pamelia sulcata* shown in Figure 5.3.

There are many different plants that are sources of dyes that act as **acid–base indicators**. Anthocyanins are a class of organic compounds found in many plants including red cabbage, red onion, blueberries, red grapes and violet leaves that change colour in the presence of acids and bases. Other natural sources of acid–base indicators include hydrangea, geranium, petunia and red rose petals and turmeric.

### Edbe pH indicator chart

Summary of the colour changes that occur in a range of natural indicators

## INVESTIGATION 5.1

### Preparing and using natural indicators

#### INTRODUCTION

Acid–base indicators are substances that in solution change colour depending on whether the solution is acidic or basic/alkaline. Various plants, including red cabbage, contain certain dyes that can act as acid–base indicators. The actual range of acidity or alkalinity over which indicators change colour varies from one indicator to another.

#### AIM

To prepare and test natural indicators on a range of substances to determine their acidity or alkalinity.



## » HYPOTHESIS

Different natural indicators will produce a range of different colours depending on the acidity or alkalinity of the substance.

## MATERIALS

- Plant material that acts as an indicator (for example, red cabbage, blueberries, turmeric or petals from violets, geranium, petunias)
- Approx. 5 mL of solution of each of the following:
  - 0.1 mol L<sup>-1</sup> NaOH (sodium hydroxide)
  - 0.1 mol L<sup>-1</sup> HCl (hydrochloric acid)
  - white vinegar
  - household ammonia
  - lemon juice
  - lemonade
  - bicarbonate of soda
  - washing powder
  - antacid tablet
  - salt water
- Distilled water
- 500 mL beaker
- 100 mL beakers (one for each type of plant material)
- Test tubes
- Test-tube rack
- 10 mL measuring cylinder
- Knife
- Cutting board
- Mortar and pestle
- Kettle (for warm water)
- Hotplate
- Spatula
- Droppers
- Stirring rod
- Strainer or filter paper and funnel
- Safety glasses

WHAT ARE THE RISKS IN DOING THIS INVESTIGATION?	HOW CAN YOU MANAGE THESE RISKS TO STAY SAFE?
Sodium hydroxide is caustic and hydrochloric acid is corrosive.	Wear safety glasses and personal protective clothing and avoid contact with skin. If spilt on skin, wash with plenty of water.



What other risks are associated with your investigation? How can you manage these?

## METHOD

- 1 For the red cabbage: Finely shred two leaves of cabbage, place in 500 mL beaker and just cover with distilled water (about 200 mL). Slowly boil the cabbage leaves until the water turns a dark reddish-purple and the leaves lose most of their colour.
- 2 Allow to cool and pour the liquid off into a clean 100 mL beaker. This is the red cabbage indicator.  
**Note:** If the colour of the solution is pale, further boiling may be necessary to concentrate the solution.
- 3 For other plant material: Cut the material into small pieces and place in a mortar and pestle. Grind the material to a paste, add 5–10 mL of warm water and stir.





- » 4 Strain the solution into a beaker to remove any solids.
- 5 Place 2 mL of each of NaOH and HCl into clean separate test tubes. Add a few drops of one indicator to each test tube until a definite colour is observed. Record the indicator and its colour in your results table.
- 6 Repeat step 5 with other indicators and record your results in the table.
- 7 Repeat steps 5 and 6 with other substances. Classify the substances as acidic, basic or neutral.
- 8 Place 2 mL of HCl in a clean test tube. Choose an indicator that produced a good colour difference between acid and base and add a few drops to the test tube.
- 9 Add NaOH a few drops at a time to the HCl test tube until the colour no longer changes. Record any colour changes that occur during the addition of NaOH.
- 10 To the test tube from step 9 add HCl a few drops at a time until the colour no longer changes. Record any colour changes.

### RESULTS

Record your results in a table.

### DISCUSSION

- 1 Identify which indicators would be most effective in identifying acidic, basic and neutral solutions. Provide a reason for your choice.
- 2 Which indicators, if any, were not effective in distinguishing between acidic, basic and neutral solutions? Suggest possible reasons for this.
- 3 Using your results, justify whether or not indicator colour change is a reversible reaction.

### CONCLUSION

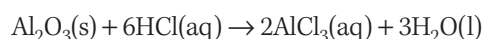
Explain why indicators give a range of colours in different acid and alkaline solutions.

While practical definitions are useful in the laboratory, chemists attempt to define substances by what they are as well as what they do. In Year 11, you learnt the definitions of acids and bases shown in the key concepts box below.

The definition of a base is quite general. It is important to note that not all oxides are basic. Most oxides formed between a non-metal and oxygen (for example, CO<sub>2</sub>, SO<sub>2</sub>) are acidic or neutral, while those formed between a metal and oxygen (for example, CaO, MgO) are basic or **amphoteric** (that is, can act as both an acid and a base). Common amphoteric oxides are those of beryllium, aluminium, zinc, tin and lead.

For example:

Aluminium oxide reacting with an acid:



Aluminium oxide reacting with a base:



- An acid is a substance that produces hydrogen ions (H<sup>+</sup>) in aqueous solution. More strictly, the hydrogen ion attaches to a water molecule and forms **hydronium ions (H<sub>3</sub>O<sup>+</sup>)**.  
e.g.  $\text{HCl} \rightarrow \text{H}^+ + \text{Cl}^-$   
or  $\text{HCl} + \text{H}_2\text{O} \rightarrow \text{H}_3\text{O}^+ + \text{Cl}^-$
- A base is a substance that either contains the oxide (O<sup>2-</sup>) or hydroxide ion (OH<sup>-</sup>) or produces hydroxide ion in aqueous solution.  
e.g.  $\text{NaOH} \rightarrow \text{Na}^+ + \text{OH}^-$   
 $\text{K}_2\text{O} + \text{H}_2\text{O} \rightarrow 2\text{K}^+ + 2\text{OH}^-$

- List two properties that can be used to distinguish between an acid and a base.
- Why must you not test the taste properties of acids and bases in the laboratory?
- Define 'acid' and 'base'.
- Explain the difference between the hydrogen and hydronium ion.
- Define 'amphoteric oxide'. Give an example.
- Write the dissociation statements for the following acids and alkalis in water.
  - Nitric acid
  - Phosphoric acid
  - Calcium hydroxide
  - Ammonium hydroxide
- Name two plant materials that are a source of acid–base indicator.
  - List the colour changes these indicators undergo in acidic and alkaline solutions.

## 5.3 Reactions of acids

Just as acids and bases can be identified by their properties, they can also be identified by the types of reactions they undergo.

The characteristic properties of acids mean they undergo similar chemical reactions. These similarities allow chemists to generalise reactions that can then be used to predict the products of most reactions involving acids.

You learnt about reactions between acids and bases, acids and carbonates and acids and metals in *Chemistry in Focus Year 11* (section 10.7 and section 11.1). Information about these types of reactions is provided below to refresh your memory.

### Acid–base reactions

Acids and bases react to form compounds called salts and water. The name given to this reaction is **neutralisation**.

If the right amount of acid and base are reacted, the resulting solution will be **neutral** (neither acidic nor basic). Neutralisation reactions can be written as the following generalised form:



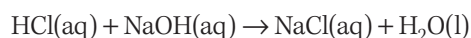
The generalised reaction given above can be used to predict the products of most reactions between an acid and a base.

Following are typical reactions between acids and bases.

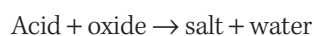
- The reaction between an acid and a hydroxide:



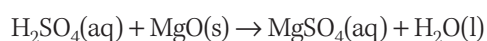
For example:



- The reaction between an acid and a basic or amphoteric oxide:



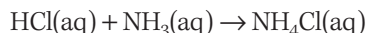
For example:



It is typical to write these reactions using the neutral species equation shown above. The  $\text{Na}^+$  and  $\text{Cl}^-$  ions are spectator ions so the net ionic equation is  $\text{H}^+(\text{aq}) + \text{OH}^-(\text{aq}) \rightarrow \text{H}_2\text{O}(\text{l})$

Another common but not typical acid–base reaction worth noting is the reaction between an acid and ammonia. This reaction does not adhere to the generalisation given above because the  $\text{H}^+$  ion attaches to the  $\text{NH}_3$  molecule (not  $\text{H}_2\text{O}$ ) to produce  $\text{NH}_4^+(\text{aq})$ .

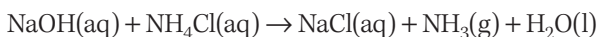
An example:



While ammonia is considered to be a weak base due the production of  $\text{OH}^-$  ions when it reacts with water:



the ammonium ion is considered to be a weak acid. This means it will react with a base to produce a salt and water; however, ammonia gas will also be produced in the reaction, as seen in the following example:

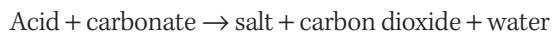


Ammonium salts such as ammonium sulfate or ammonium nitrate are commonly used as fertilisers. This is one reason why a farmer would not treat a field with an ammonium compound at the same time as using an alkali (a soluble base) like lime. The ammonium salt will react with the base to give off ammonia that will escape into the atmosphere as a gas, and so not be available to the plants.

## Acid–carbonate reactions

Many products, such as bread and sponge cakes, have a honeycomb structure that contains bubbles. These bubbles are formed by a gas during cooking, causing the mixture to rise. The gas is carbon dioxide and is formed by adding a carbonate ( $\text{CO}_3^{2-}$ ) or hydrogen carbonate ( $\text{HCO}_3^-$ ) and an acid to the cooking mixture. When an acid and carbonate react, they produce a salt, carbon dioxide and water.

This can be represented by the general equation:



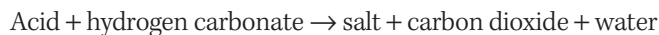
The following reactions are examples of reactions between an acid and calcium carbonate:



Figure 5.4 shows the vigorous reaction between calcium carbonate and hydrochloric acid, resulting in fizzing and production of carbon dioxide.

A hydrogen carbonate ion has the formula  $\text{HCO}_3^-$ . Compounds containing the hydrogen carbonate ion undergo similar reactions with acids to those containing the carbonate ion.

When an acid and a hydrogen carbonate react they will also produce a salt, water and carbon dioxide according to the general equation:



The following reactions are examples of reactions between an acid and sodium hydrogen carbonate:

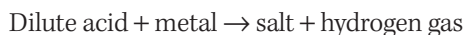


**FIGURE 5.4** Marble chips (calcium carbonate) react vigorously with hydrochloric acid.

## Acid–metal reactions

Another type of reaction that acids undergo is with metals. This reaction is what occurs when rain becomes acidic due to pollutants in the air. The acid rain reacts with metals causing them to corrode more quickly. As you learnt in Year 11 (section 11.1), most metals (except copper, silver, gold and platinum) react with dilute hydrochloric and sulfuric acids to form hydrogen gas, although tin and lead reactions are quite slow. The reaction between metals and dilute acid can be represented by a general equation.

When an acid and metal react they produce a salt and hydrogen gas according to the general equation:



The following neutral species equations demonstrate examples of reactions between an acid and magnesium metal:

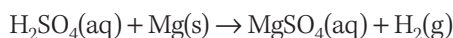
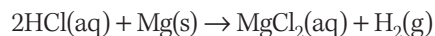
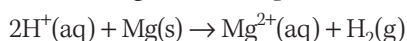


Figure 5.5 shows hydrogen gas produced in the reaction between magnesium and hydrochloric acid. Remember, it is actually the hydrogen ion ( $\text{H}^+$ ) that acids produce in aqueous solution that reacts with the metal so the equations above can be written in the following net ionic equation form:



As you can see, there is a pattern to the reactions of acids. Knowing the pattern means the products of a reaction can be predicted.



**FIGURE 5.5** The reaction between magnesium metal and dilute hydrochloric acid



Reactions of acids



Information and communication technology capability

- Neutralisation reactions can be written as the following generalised form:  
Acid + base  $\rightarrow$  salt + water
- When an acid and carbonate react they produce a salt, carbon dioxide and water. This can be represented by the general equation:  
Acid + carbonate  $\rightarrow$  salt + carbon dioxide + water
- When an acid and a hydrogen carbonate react they will also produce a salt, water and carbon dioxide according to the general equation:  
Acid + hydrogen carbonate  $\rightarrow$  salt + carbon dioxide + water
- When an acid and metal react they produce a salt and hydrogen gas according to the general equation:  
Dilute acid + metal  $\rightarrow$  salt + hydrogen gas



### Acids and bases

The online lab has many different resources showing properties and reactions of acids and bases as well as pH and indicators. View the video to see reactions or use the simulator to conduct your own.

- 1 Complete the following general equations for the reactions of acids.
  - a Acid + base  $\rightarrow$
  - b Acid + carbonate  $\rightarrow$
  - c Acid + metal  $\rightarrow$
- 2 Define 'neutralisation'. Give an example.
- 3 Write the net ionic equation for the reaction between an acid and a hydroxide.

## CHECK YOUR UNDERSTANDING

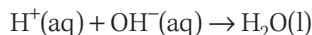
5.3



- 4 a What is the difference between a carbonate ion and a hydrogen carbonate ion?  
 b How does the reaction between an acid and a carbonate differ from the reaction between an acid and a hydrogen carbonate?
- 5 Write balanced neutral species equations for the following reactions.  
 a Nitric acid with potassium hydroxide  
 b Sulfuric acid with zinc oxide  
 c Hydrofluoric acid with magnesium hydroxide  
 d Phosphoric acid with ammonia  
 e Acetic acid with sodium oxide  
 f Calcium oxide with ammonium nitrate
- 6 Using the general reactions as a guide, write balanced equations for the reactants given below.  
 a  $\text{H}_2\text{SO}_4(\text{aq}) + \text{NaOH}(\text{aq}) \rightarrow$   
 b  $\text{CH}_3\text{COOH}(\text{aq}) + \text{Ca}(\text{OH})_2(\text{aq}) \rightarrow$   
 c  $\text{HNO}_3(\text{aq}) + \text{Fe}(\text{s}) \rightarrow$   
 d  $\text{HCl}(\text{aq}) + \text{Zn}(\text{s}) \rightarrow$   
 e  $\text{HF}(\text{aq}) + \text{CaHCO}_3(\text{s}) \rightarrow$   
 f  $\text{HNO}_3(\text{aq}) + \text{CuCO}_3(\text{s}) \rightarrow$

## 5.4 Neutralisation reactions

As you learnt in the previous section, a neutralisation reaction occurs when an acid and a base react to form a salt and water. The net ionic equation for this reaction is:



However, there is another product that has not been included in this equation – heat energy.

### Enthalpy of neutralisation

As you learnt in *Chemistry in Focus Year 11*, chemical reactions involve breaking the bonds in the reactants, then forming new bonds to make the products. These changes involve energy.

Energy is stored in the chemical bonds of the reactants and the products. The law of conservation of energy states that energy cannot be created or destroyed; it can only be changed from one form to another. Energy is needed to break bonds and is released when new bonds are formed.

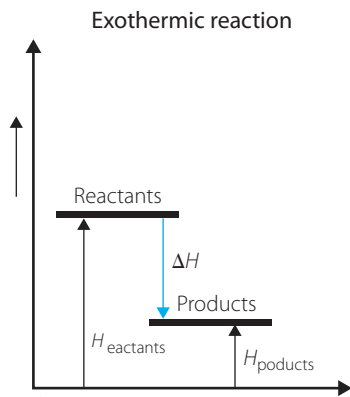
**Enthalpy** is a measure of the total energy possessed by a substance or group of substances. The change in enthalpy, more commonly referred to as the heat of reaction, is given the symbol  $\Delta H$ . It is measured in  $\text{kJ mol}^{-1}$ .

The **change in enthalpy** for a chemical reaction ( $\Delta H$ ) is defined as the energy change per mole of specified reactant or product when the reaction occurs at constant pressure:

$$\Delta H = \text{enthalpy of products} - \text{enthalpy of reactants}$$

Since change in enthalpy is defined as the energy absorbed during a chemical reaction, by definition  $\Delta H$  is positive. Therefore, a negative  $\Delta H$  indicates that energy has been released during a chemical reaction.

**Exothermic** reactions are reactions in which the energy of the reactants is greater than the energy of the products. Energy is released in exothermic reactions so they have negative  $\Delta H$  values. **Endothermic** reactions have positive  $\Delta H$  values. This is because the energy of the products is greater than the energy of the reactants, so energy is absorbed during an endothermic reaction.



**FIGURE 5.6** In an exothermic reaction, energy is released since energy of reactants is greater than energy of products.

During a neutralisation reaction there is a change in enthalpy due to the chemical reaction that occurs. As you learnt in *Chemistry in Focus Year 11*, enthalpy change ( $\Delta H$ ) depends on the concentration of any reactants and products present in solution and the pressure of any gas involved in the reaction.

The term 'standard enthalpy change' was defined as:

'The standard enthalpy change,  $\Delta H^\ominus$ , for a reaction is the enthalpy change when the reaction occurs with all reactants and products present in their standard states. Standard conditions are a temperature of  $25^\circ\text{C}$  or  $298\text{K}$  and  $100\text{kPa}$  pressure.'

This is also applied when defining standard enthalpy of neutralisation.

The **standard enthalpy of neutralisation** is the enthalpy change when solutions of an acid and alkali react together under standard conditions ( $25^\circ\text{C}$  and  $100\text{kPa}$ ) to produce exactly 1 mole of water.

## Measuring enthalpy

As you learnt in *Chemistry in Focus Year 11*, a common way to measure energy changes in the laboratory is to measure the change in temperature of water or a solution.

The **specific heat capacity** of water is  $4.18\text{J K}^{-1}\text{g}^{-1}$ . This means that 4.18 joules of energy is needed to increase the temperature of 1 gram of water by 1K.

The total amount of energy needed to heat a substance is dependent on the:

- ▶ mass of the substance
- ▶ substance (that is, the specific heat capacity of the substance involved)
- ▶ increase in temperature required.

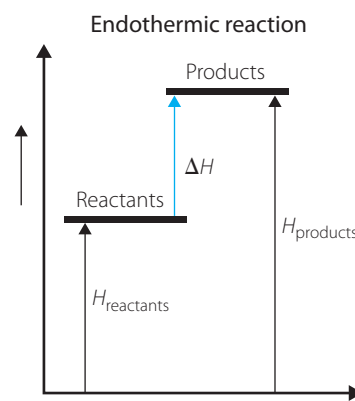
This can be written as a mathematical equation:

$$q = mC\Delta T$$

where:

- ▶  $q$  = quantity of heat involved, measured in joules (J)
- ▶  $m$  = mass of the substance, measured in grams (g)
- ▶  $C$  = specific heat capacity of the substance, measured in  $\text{J K}^{-1}\text{g}^{-1}$
- ▶  $\Delta T$  = change in temperature (final temperature – initial temperature), measured in kelvin (K).

If the temperature change is positive, then the temperature has increased and the substance has lost energy. If the temperature change is negative, then the temperature has decreased and the substance has gained energy.



**FIGURE 5.7** In an endothermic reaction, energy is absorbed since energy of reactants is less than energy of products.



Determining the enthalpy of neutralisation experimentally

## INVESTIGATION 5.2

### Measuring the enthalpy of neutralisation

#### INTRODUCTION

When a neutralisation reaction occurs there is a change in enthalpy. The standard enthalpy of neutralisation is the enthalpy change when solutions of an acid and alkali react together under standard conditions to produce exactly 1 mole of water. In this reaction you will determine the standard enthalpy of neutralisation for a reaction between aqueous sodium hydroxide solution with hydrochloric acid. You will also determine whether or not there is a difference in enthalpy when solid sodium hydroxide is used instead of the aqueous solution. >>



## » AIM

To determine the enthalpy of neutralisation and the effect of the state of the reactants.

## HYPOTHESIS

Write a suitable hypothesis for this investigation.

## MATERIALS

- 4g NaOH(s)
- 100 mL 1.0 mol L<sup>-1</sup> HCl
- 50 mL 2.0 mol L<sup>-1</sup> HCl
- 50 mL 2.0 mol L<sup>-1</sup> NaOH
- 100 mL measuring cylinder
- -10–110°C thermometer or temperature probe and data logger
- Spatula
- Electronic balance
- 2 polystyrene cups
- Safety glasses



WHAT ARE THE RISKS IN DOING THIS INVESTIGATION?	HOW CAN YOU MANAGE THESE RISKS TO STAY SAFE?
NaOH is caustic. HCl is corrosive.	Use a spatula to transfer the NaOH(s). Use safety glasses, and personal protective clothing. Dispose of as directed by your teacher to protect from splashing.

What other risks are associated with your investigation? How can you manage these?

## METHOD

### PART A

- 1 Pour 100 mL 1.0 mol L<sup>-1</sup> HCl into a polystyrene cup.
- 2 Measure the temperature of this solution using the thermometer or temperature probe.
- 3 Accurately weigh out approximately 4.0 g of NaOH(s) and add this to the same polystyrene cup.
- 4 Use the thermometer to stir, then record the highest or lowest temperature reached.

### PART B

- 1 Pour 50 mL of 2.0 mol L<sup>-1</sup> NaOH into a polystyrene cup.
- 2 Measure the temperature of the NaOH using the thermometer or temperature probe.
- 3 Measure 50 mL of 2.0 mol L<sup>-1</sup> HCl and record its initial temperature.
- 4 Average the initial temperatures of the NaOH and HCl – this is the initial temperature of this experiment.
- 5 Pour the HCl into the polystyrene cup containing the NaOH, stir and record the highest or lowest temperature reached.

## RESULTS

### PART A

Record the following data.

- Volume of HCl used
- Initial temperature of HCl
- Mass of solid NaOH used
- Final temperature of solution



## » RESULTS

### PART B

Record the following data:

- Total volume of solution used
- Initial temperature of solution
- Final temperature of solution

### ANALYSIS OF RESULTS

Assume heat capacity ( $C$ ) of each solution is  $4.18 \text{ J K}^{-1} \text{ g}^{-1}$ .

Data for:

- part A will be used to determine  $\Delta H$  of neutralisation when using solid sodium hydroxide
  - part B will be used to determine  $\Delta H$  of neutralisation when using aqueous sodium hydroxide.
- For each part, calculate:

- 1 the heat of reaction ( $q = mC\Delta T$ )
- 2 the number of moles of NaOH and HCl that took part in the reaction
- 3 the number of moles of water produced
- 4 the heat of reaction per mole of water.

### DISCUSSION

- 1 Compare the heat of reaction per mole of water for part A and part B and suggest reasons for any differences between the values obtained.
- 2 The theoretical value for enthalpy changes of neutralisation for reactions between solutions of strong acids and bases is around  $-57 \text{ kJ mol}^{-1}$  (of water). Explain any discrepancies in your data.

### CONCLUSION

Evaluate your hypothesis.

### EXTENSION

Evaluate if it would be better to clean up an acid spill with a solid or aqueous base.

## Applications of neutralisation reactions

Neutralisation reactions are important in our everyday life as well as in industry and the environment.

### Neutralisation and me

In many natural systems, including that of our bodies, the balance of acid and/or base is important in maintaining the health of the system and this is regulated by naturally occurring processes. For example, our stomach produces hydrochloric acid to aid with the digestion of food and to kill many harmful micro-organisms that may have also been swallowed. However, if the system is upset and too much hydrochloric acid is produced, you end up with heartburn or indigestion. The problem is commonly fixed by taking an antacid, which contains a base such as magnesium hydroxide ( $\text{Mg}(\text{OH})_2$ ) or aluminium hydroxide ( $\text{Al}(\text{OH})_3$ ), which neutralises the excess acid. Other active ingredients commonly found in antacids include magnesium oxide, magnesium carbonate, calcium carbonate and sodium hydrogen carbonate.

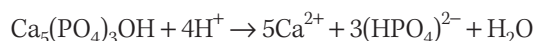


**FIGURE 5.8** Antacids contain a base that neutralises excess acid in the stomach.

In our digestive tract, the acidic component of the partially digested food from our stomach is neutralised by bile produced by the liver. This is because an alkaline environment is needed for the enzymes of the small intestine to work best and for nutrients to be able to be absorbed through the intestinal wall.

Many of the foods we eat and drink are acidic. For example, apples contain malic acid, tea contains tannic acid and carbonic acid is found in carbonated drinks. Acid is also produced when the bacteria in your mouth consume sugar from the food you eat. The enamel that makes up our teeth is 95% hydroxyapatite ( $\text{Ca}_5(\text{PO}_4)_3\text{OH}$ ), and is easily decayed in the presence of an acid by a process called demineralisation.

The acid reacts with the enamel causing it to break down according to the reaction:



Toothpaste is alkaline and used to neutralise the acids in the mouth as well as removing food particles that produce acids when they decay. Typically, toothpaste contains mild abrasives such as calcium carbonate, aluminium oxides and magnesium carbonates that remove food particles and neutralise acids. Many toothpastes also contain fluoride that strengthens and remineralises the tooth enamel by replacing the  $\text{OH}^-$  ions in the hydroxyapatite, forming fluorhydroxyapatite ( $\text{Ca}_5(\text{PO}_4)_3\text{F}$ ), which is more resistant to acids.

The reaction between an acid and carbonate or hydrogen carbonate to produce a salt, water and carbon dioxide is important in cooking. The carbon dioxide produced forms thousands of little bubbles in the dough causing bread, cakes and other baked goods to rise when they go in the oven. Baking soda, which is sodium hydrogen carbonate, is basic. When this combines with an acidic ingredient such as buttermilk, lemon juice or sour cream, it reacts to produce carbon dioxide, which causes the dough to rise.

Baking powder contains both an acid and a base in a dry form. The base is sodium hydrogen carbonate and usually tartaric acid (cream of tartar). The components of baking powder react with each other in the presence of a liquid like water or milk producing the carbon dioxide needed for the mixture to rise.



**FIGURE 5.9** Sponge cakes rise due to the production of tiny bubbles of carbon dioxide when an acid and carbonate react.

## Neutralisation and industry

Use of neutralisation is important in many industries and to manage wastes produced during industrial processes.

In agriculture, the neutralisation of soil is important since the ability of plants to take up nutrients from the soil is affected by how acidic or alkaline the soil is. While most plants grow well in soil that is around neutral, some plants grow well in soil that is more acidic (for example, azaleas, blueberries, parsley, potato), while other plants grow well in soil that is more alkaline (for example, lilac, thyme, leek).

If soil is too acidic, slaked lime (calcium hydroxide) or limestone (calcium carbonate) is added to the soil to neutralise the acid. Other organic sources of calcium carbonate such as eggshells or oyster shells could also be used.

If soil is too alkaline, then substances that can act as acids, including gypsum (calcium sulfate) and powdered sulfur can be used to neutralise the alkaline component. Naturally occurring acidic materials including pine needles, coffee grounds and fresh manure could also be used.

As you learnt in section 5.2, many plants contain natural indicators that change colour in the presence of an acid and a base. The hydrangea is unique among plants because its flower colour changes depending on whether the soil is acidic or alkaline. The shrub produces blue flowers when grown in acidic soil and pink or red flowers when grown in neutral to basic soils, as shown in Figure 5.10. The colour of hydrangea blooms can be manipulated by changing soil acidity.



**FIGURE 5.10** Hydrangeas produce pink flowers in alkaline soils and blue flowers in acidic soil.

Fertilisers containing ammonium sulfate ( $(\text{NH}_4)_2\text{SO}_4$ ) or ammonium nitrate ( $\text{NH}_4\text{NO}_3$ ) are made using a neutralisation reaction between sulfuric acid or nitric acid and ammonia gas ( $\text{NH}_3$ ).

In the textile industry there are many processes that occur in alkaline conditions and neutralisation is used at the end of many of these steps.

Fabric made from natural fibres is often difficult to dye because the fibres contain natural oils and waxes. These oils and waxes are removed by a process called scouring. This involves treating the fabric with a strong alkali solution of sodium hydroxide or a mixture of sodium hydroxide and sodium carbonate at boiling temperature for 1–2 hours. At the end of the process, the fabric is put through a cold rinse with acetic acid to neutralise the sodium hydroxide.

Much wastewater from industrial processes is acidic or alkaline. If this water was allowed to enter creeks and rivers untreated it could cause a significant amount of environmental damage. The application of neutralisation varies between industries.

For example, wastewater from mine drainage contains a large amount of acidity because of the presence of sulfuric acid produced from the oxidation of pyrite. This acid water is neutralised with calcium oxide before the land is reclaimed after mining.

The most widely used methods of neutralising acidity are:

- ▶ passing the acidic water through a limestone (calcium carbonate) bed
- ▶ mixing acid waste with lime (calcium oxide) slurries
- ▶ supplementing acidic wastewater with caustic soda (sodium hydroxide) or soda ash (sodium carbonate).

Acidic wastes are neutralised either by adding lime alkalis, usually quicklime ( $\text{CaO}$ ) or slaked lime ( $\text{Ca}(\text{OH})_2$ ) or sodium alkalis, usually caustic soda ( $\text{NaOH}$ ) or soda ash ( $\text{Na}_2\text{CO}_3$ ). Calcium and magnesium oxides may also be used; however, because they are only moderately soluble, they are typically used in slurries.



If wastewater is too alkaline, it is commonly neutralised using sulfuric acid, hydrochloric acid or nitric acid. Amongst these, sulfuric acid is most widely used.

Industrial spills involving acids and bases must be dealt with quickly due to the corrosive nature of these chemicals. Neutralisation reactions are used to deal with spills. Sodium carbonate or sodium hydrogen carbonate is widely used to neutralise acid spills, while dilute sulfuric or hydrochloric acid are used to neutralise base spills.

- The change in enthalpy for a chemical reaction ( $\Delta H$ ) is defined as the energy change per mole of specified reactant or product when the reaction occurs at constant pressure.
- $\Delta H = \text{enthalpy of products} - \text{enthalpy of reactants}$
- The standard enthalpy of neutralisation is the enthalpy change when solutions of an acid and alkali react together under standard conditions (25°C and 100 kPa) to produce exactly 1 mole of water.

### CHECK YOUR UNDERSTANDING

5.4

- Write the net ionic equation for neutralisation.
  - Identify any bonds being broken and any bonds being formed in this reaction.
  - Based on your answer to **b**, justify if a neutralisation reaction is exothermic or endothermic.
  - Rewrite the net ionic equation for neutralisation including the energy term.
- Define the following.
  - Change in enthalpy for a reaction
  - Standard enthalpy of neutralisation
- Explain why the enthalpy of neutralisation differs when using solid reactants to using aqueous reactants.
- In a calorimeter, the reaction between 100 ml of 0.100 mol L<sup>-1</sup> HCl and 100 mL of 0.100 mol L<sup>-1</sup> KOH causes a temperature rise of 0.70°C.
  - Write the net ionic equation for the reaction.
  - Calculate the heat evolved in this reaction.
  - Calculate the heat of reaction per mole of water.
  - Calculate the temperature rise if 200 mL of 0.100 mol L<sup>-1</sup> HCl and 200 mL of 0.100 mol L<sup>-1</sup> KOH was mixed in the same calorimeter.
- Give two examples of the use of neutralisation reactions in everyday life.
  - Write a balanced equation for one of these examples.
- Describe how the alkalinity of soil can be reduced.
- Write a balanced equation for the production of ammonium sulfate.
- A gardener has a hydrangea shrub that produces blue flowers.
  - What does that indicate about the soil?
  - What could they do to have the shrub produce pink flowers?
- Explain why wastewater from industry should be treated so that it is not too acidic or alkaline.
  - Describe how acidity in wastewater can be neutralised.
- Suggest why sodium carbonate or sodium hydrogen carbonate is preferred to sodium hydroxide when cleaning up acid spills.

## 5.5

## Changes in understanding of acids and bases

Over time scientific understanding of acids and bases has changed and so have the definitions and models of these substances. The definition of an acid has changed several times over the last 250 years.

Initially, ancient Greeks identified sour-tasting substances as *oxein*, which was translated to Latin as *acetum* and later anglicised to the current name 'acid'. Later these substances were also found to change the colour of litmus paper and corrode metals (in the case of acids).

Bases were known to counteract the effects of acids. They were originally known as *alkaline*, from the Arabic word for roasting, due to the production of soap that involved roasting ashes and reacting them with water and slaked lime.

Earlier in this chapter, you learnt how acids and bases can be identified by common properties that provide an operational definition of these substances. These properties can be observed in the laboratory. While operational definitions are useful in the laboratory, although there are also exceptions and practical difficulties in testing taste, chemists attempt to develop a conceptual definition (that is, to define substances by what they are as well as what they do).

During the 18th century, French scientist Antoine Lavoisier (1743–94) studied the composition and structure of these substances and began to inform our modern understanding of acids and bases.

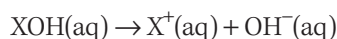
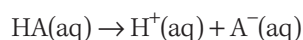
Around 1776, Lavoisier published a paper in which he proposed that oxygen was the component in a compound responsible for the compound being an acid. This was later disproved because it was found that many acids did not contain oxygen and some basic substances did; however, this idea is historically important because it is the first attempt to chemically characterise an acid.

English chemist Humphry Davy challenged this idea following a series of experiments in which he demonstrated HCl, H<sub>2</sub>S and H<sub>2</sub>Te were acids, showing that oxygen could not be responsible for acidity. This led him to develop the idea that hydrogen was the key component that gives an acid its properties and proposed that acids were substances that contained hydrogen that could be replaced by a metal.

### The Arrhenius theory

In the late 19th century, Swedish chemist Svante Arrhenius attempted to explain acids and bases in terms of the particles they produced in aqueous solution. He proposed that an acid was a substance that ionised in solution to produce hydrogen ions (H<sup>+</sup>) and that a base was a substance that in solution produced hydroxide ions (OH<sup>-</sup>).

So if HA is used to represent an acid and XOH a base then, according to Arrhenius:



While Arrhenius' theory was consistent with all the acids known at that time and many of the bases, it could not explain why ammonia was a base. There were other limitations of Arrhenius' theory.

The nature and role of the solvent was not considered in the Arrhenius' model. An acid should be expected to exhibit acidic properties in any solvent. While the model works for aqueous solutions when an organic solvent (such as benzene) is used, many acids and bases do not dissociate.

According to this model, all salts produced by reactions of an acid and a base should be neutral. In reality, this is not the case. For example, a neutralisation reaction between acetic acid and sodium hydroxide results in a basic solution.

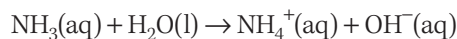
Not all bases are soluble, thus OH<sup>-</sup> ions cannot be produced and when bases are dissolved in non-aqueous solvents, no hydroxide ion is present in the resulting solution. This means an OH<sup>-</sup> ion is not necessary for a substance to be identified as a base.



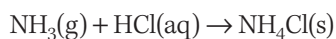
The  $\text{H}^+$  ion does not exist as such in aqueous solutions. It bonds to a water molecule to produce the hydronium ion ( $\text{H}_3\text{O}^+$ ).

## The ammonia dilemma

The weak base ammonia challenged Arrhenius' definition of a base. The dilemma was that either ammonia was not a base or the definition was inaccurate or incomplete. Some chemists argued that the definition was acceptable because when ammonia reacts with water, the following reaction occurs:



But ammonia gas reacts with hydrochloric acid fumes to form ammonium chloride. There is no water and no  $\text{OH}^-$  or  $\text{O}^{2-}$  ions are involved, as shown in the reaction:



This reaction showed that the original definition of an acid and a base needed to be redefined.

## INVESTIGATION 5.3

### Teacher demonstration: White smoke

#### INTRODUCTION

Bases, such as ammonia, were originally described by their reaction with water. They produced hydroxide ions ( $\text{OH}^-$ ) and by definition the hydroxide ions gave the basic nature to the substance. When water is not present, will ammonia still act as a base? In this reaction, fumes from hydrochloric acid react with the gaseous ammonia forming a white smoke substance when they meet.

#### AIM

To demonstrate that acid and base reactions can occur without water.

#### MATERIALS

- Concentrated ammonia solution ( $15 \text{ mol L}^{-1}$ )
- Concentrated hydrochloric acid ( $10 \text{ mol L}^{-1}$ )
- Glass tubing at least 500 cm long and 2 cm wide
- Retort stands with boss heads and clamps
- Cotton wool
- Bungs with small hole to hold cotton wool
- Universal indicator paper (optional)
- Safety glasses

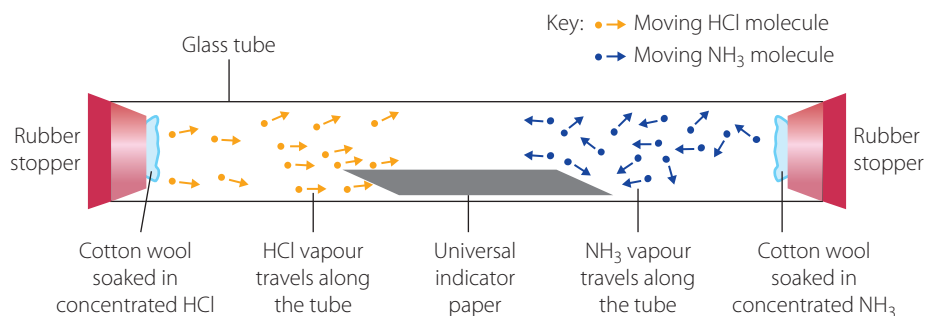


FIGURE 5.11 The reaction between ammonia gas and hydrogen chloride gas



WHAT ARE THE RISKS IN DOING THIS INVESTIGATION?	HOW CAN YOU MANAGE THESE RISKS TO STAY SAFE?
Ammonia gas and concentrated ammonia solution ( $15\text{--}16\text{ mol L}^{-1}$ or $28\text{--}30\%$ w/w) is highly toxic and irritating to the lungs due to ammonia gas evolved. It is corrosive to skin and eyes and may cause asthma attack.	Avoid inhalation of extremely pungent vapour. Do not mix with halogens or materials that release halogens. Wear gloves and safety glasses. Teacher to perform the demonstration in a fume cupboard.
Concentrated hydrochloric acid (variable $10\text{--}12\text{ M}$ , $32\text{--}37\%$ w/w; density $1.16\text{--}1.18\text{ g mL}^{-1}$ ) is highly irritating to the lungs due to the HCl gas evolved. It is highly corrosive to skin and eyes and toxic if ingested.	Wear gloves and safety glasses and perform the demonstration in a fume cupboard. Do not breathe vapour. Avoid splashes in eyes or on skin.
Glassware may crack or break.	Handle glass with care. Inspect and discard any chipped or cracked beakers, no matter how small the damage. Sweep up broken glass with brush and dustpan; do not use fingers.

What other risks are associated with your investigation? How can you manage these?

#### METHOD

- 1 Use the clamps and retort stand to ensure that the glass is secure and horizontal in a functioning fume cupboard. Ensure that the bottles are also in the fume cupboard. If universal indicator paper is being used, place it in the glass tube (Figure 5.11).
- 2 Open the bottle of ammonia solution cautiously. Ensure that the mouth of the bottle is not facing anyone.
- 3 Dip one of the cotton wool wads into the ammonia solution and then quickly secure it in the glass tube and replace the lid back on the ammonia bottle.
- 4 Repeat steps 2 and 3 with the other cotton wad and the hydrochloric acid solution.

#### RESULTS

Observe what occurs in the glass tube.

#### DISCUSSION

- 1 What was the most likely substance that formed?
- 2 If a strip of universal indicator paper was used, what colour did it turn?
- 3 Write the equation for the reaction that occurred between ammonia and hydrochloric acid.
- 4 Which reactant acted as a base? Which one acted as an acid?

#### CONCLUSION

Is ammonia acting as a base in this case? Is the definition of a base as a substance that produces  $\text{OH}^-$  or  $\text{O}^{2-}$  ions justified by this experiment?

#### EXTENSION

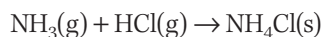
- 1 Why is it important that only the vapours are used?
- 2 Explore how the vapours travel in the tube, explaining the white smoke.

## Redefining acids – the Brønsted–Lowry theory

It was the Danish chemist Brønsted and the English chemist Lowry who refined the definition of an acid and a base to take ammonia into account:

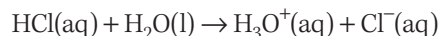
- An acid is a substance that donates one or more protons or hydrogen ions ( $\text{H}^+$ ).
- A base is redefined as a substance that accepts one or more protons.

The Brønsted–Lowry definition is broader than the Arrhenius definition. Consider the following reaction between ammonia gas and fumes of hydrochloric acid:

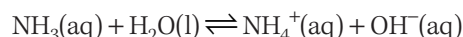


In this reaction, ammonia accepts a proton to form an ammonium ion ( $\text{NH}_4^+$ ) and is acting as a base. HCl is acting as an acid since it donates a proton to form a chloride ion ( $\text{Cl}^-$ ).

When hydrochloric acid reacts with water, the HCl molecule is acting as an acid and the water is acting as a base. The hydrochloric acid ionises to form a hydronium ion ( $\text{H}_3\text{O}^+$ ) and a chloride ion ( $\text{Cl}^-$ ). The water molecules are acting as a base because they accept the  $\text{H}^+$  ion:



In the reaction of ammonia with water:

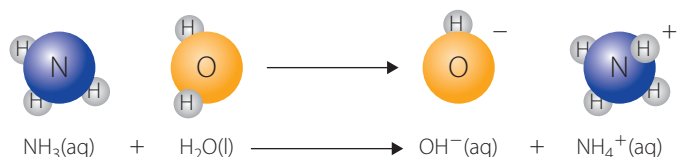


ammonia is acting as a base and water is acting as an acid, as illustrated in Figure 5.12.

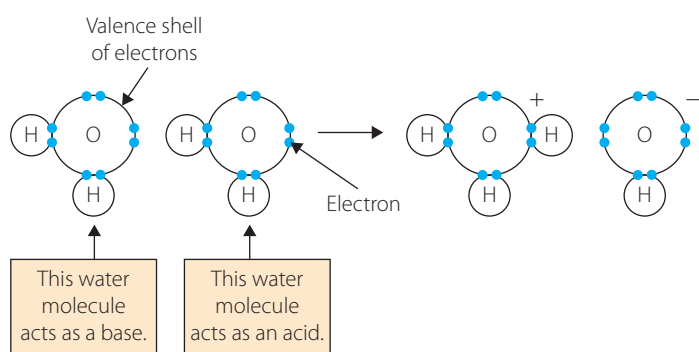
In these two examples, water is capable of acting as an acid and a base. The water is called **amphiprotic** and is able to accept or donate a proton and can act as an acid and a base, as illustrated in Figure 5.13.

The Brønsted–Lowry definition of an acid as a proton donor and a base as a proton acceptor meant that bases became the mirror companion of acids, merely simple receptors. The measurement of hydronium ion concentration became key to defining the degree of acidity.

While the Brønsted–Lowry model of acids and bases overcomes most of the limitations of the Arrhenius model, it still has some limitations. This is because for a substance to be identified as an acid or base, a  $\text{H}^+$  must be transferred in the reaction. This model requires the presence of a solvent, which has a hydrogen attached to an oxygen or nitrogen (for example, water, ammonia, acetic acid). However, it



**FIGURE 5.12** Reaction of the ammonia molecule with water to form a hydroxide ion and an ammonium ion

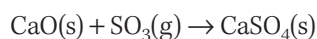


**FIGURE 5.13** The amphiprotic nature of water. Water can act as an acid and as a base, depending on what species is present.

does not explain the acid–base behaviour of substances in non-aqueous solvents where a proton is not involved.

Another limitation is that the Brønsted–Lowry model cannot explain reactions between acidic oxides, such as  $\text{CO}_2$ ,  $\text{SO}_2$ ,  $\text{SO}_3$  and basic oxides like  $\text{CaO}$ ,  $\text{BaO}$ ,  $\text{MgO}$ , which take place even where there is no solvent.

For example:



There are also substances such as  $\text{BF}_3$  and  $\text{AlCl}_3$  that are known to act as acids but do not have a hydrogen present, so they cannot donate a proton.

## Lewis' definition

Gilbert Lewis wanted a definition of an acid and a base that was not limited or restricted by the chemical environment. The definition should allow an acid and a base to be identified even if no solvent is present.

Lewis proposed the definition that:

- ▶ an acid is an electron pair acceptor
- ▶ a base is an electron pair donor.



### Theories of acids and bases

Compares Arrhenius and Brønsted–Lowry theories of acids and bases

This definition is broader than the Brønsted–Lowry theory because it does not require either a proton or a solvent. A Lewis acid is any atom, ion or molecule that can accept electrons, while a Lewis base is any atom, ion or molecule capable of donating electrons.

In Figure 5.13, you can see one of the water molecules has donated an electron pair to a  $\text{H}^+$ , thus making it a Lewis base, while the  $\text{H}^+$  from the other water molecule has accepted the electron pair, thus making it a Lewis acid.

The Lewis definition explains why  $\text{BF}_3$  reacts with ammonia. The boron in the  $\text{BF}_3$  molecule is a Lewis acid because it accepts a non-bonding electron pair from the nitrogen in  $\text{NH}_3$ , which is a Lewis base, forming the compound  $\text{BF}_3\text{NH}_3$ .

While these two definitions are complimentary, there are also instances where a substance is classified as an acid or base according to one definition but not the other. While all Brønsted–Lowry acids and bases are Lewis acids and bases, the reverse is not true. This is shown by the example above.



Check your understanding

- Brønsted–Lowry definition:
  - An acid is a substance that donates one or more protons or hydrogen ions ( $\text{H}^+$ ).
  - A base is redefined as a substance that accepts one or more protons.
- Lewis definition:
  - An acid is an electron pair acceptor
  - A base is an electron pair donor

- 1 What was the earliest definition of acids and bases?
- 2 What is the difference between an operational definition and a conceptual definition?
- 3 What was the difference between Lavoisier's and Davy's definition of an acid?
- 4 **a** Give the Arrhenius definition of an acid and a base.  
**b** Why did ammonia challenge this definition?  
**c** List the limitations of the Arrhenius theory of acids and bases.
- 5 **a** How did Brønsted–Lowry theory deal with the ammonia problem?  
**b** Give the Brønsted–Lowry definition of an acid and a base.  
**c** Illustrate this using an example.
- 6 Explain how water can act as both an acid and a base.
- 7 The equation of the reaction between a solution of ammonium chloride and a solution of sodium hydroxide is:



Which substance is acting as an acid and which is acting as a base? Explain your reasoning.

- 8 What are the limitations of the Brønsted–Lowry theory of acids and bases?
- 9 How does the Lewis definition of acids and bases address the limitations of the Brønsted–Lowry theory?
- 10 **a** What is the relationship between Lewis acids and bases and Brønsted–Lowry acids and bases?  
**b** Use an example to illustrate a difference.

CHECK YOUR UNDERSTANDING

5.5

**IMPORTANT NEW TERMS**

After studying this chapter you should know the meaning of the following terms:

acid (p. 119)

acid–base indicator (p. 122)

alkali (p. 121)

amphiprotic (p. 138)

amphoteric (p. 124)

base (p. 119)

change in enthalpy (p. 128)

endothermic (p. 128)

enthalpy (p. 128)

exothermic (p.128)

hydronium ion (p. 124)

neutral (p. 125)

neutralisation (p. 125)

nomenclature (p. 119)

oxyacid (p. 120)

specific heat capacity (p. 129)

standard enthalpy of neutralisation (p. 129)

**AFTER STUDYING THIS CHAPTER YOU SHOULD KNOW:**

- ▶ the definitions for all terms in the important new terms list
- ▶ the rules for naming inorganic acids and bases
- ▶ the common properties of acids and bases
- ▶ how indicators are used to identify acids and bases
- ▶ the general equations for reactions of acids with bases, carbonates and metals
- ▶ applications of neutralisation reactions in everyday life and industry
- ▶ how definitions of acids and bases have changed over time
- ▶ the Arrhenius definition of an acid and a base
- ▶ the limitations of the Arrhenius theory of acids and bases
- ▶ the Brønsted–Lowry definition of acids and bases
- ▶ the limitations of the Brønsted–Lowry theory.

**YOU SHOULD BE ABLE TO:**

- ▶ correctly name and write the formula of inorganic acids and bases
- ▶ write dissociation statements for acids and alkalis in water
- ▶ predict the products of reactions of acids with bases, carbonates and metals
- ▶ write balanced equations for the reactions of acids with bases, carbonates and metals
- ▶ calculate enthalpy of neutralisation
- ▶ explain how definitions of acids and bases have changed over time
- ▶ compare theories of acids and bases.

# 5 CHAPTER REVIEW QUESTIONS



Review quiz

- Explain why it is important to have an agreed upon chemical nomenclature system.
- Name the following substances and classify them as acids or bases.
  - $\text{H}_3\text{PO}_4$
  - $\text{HNO}_2$
  - $\text{CuO}$
  - $\text{NH}_3$
- Write the formula for the following substances.
  - Acetic acid
  - Sulfurous acid
  - Potassium oxide
  - Ammonium hydroxide
- Explain what is meant by the statement: 'All alkalis are bases but not all bases are alkalis' using examples.
- Write the dissociation statements for the following acids and alkalis in water.
  - Sulfuric acid
  - Hydrofluoric acid
  - Sodium oxide
  - Potassium hydroxide
- An indicator is a substance that takes on different colours as the acidity and basicity of a solution changes. Different indicators change colour over different acidity–basicity ranges, as shown in Table 5.1.  
Answer the following questions using Table 5.1 as a guide.
  - Solution A is red in blueberries, while solution B is colourless in curry powder.
    - Which is the more acidic? Explain how you determined this.
    - What further test could be conducted to confirm this answer?
  - Four different solutions (w, x, y, z) were tested with different indicators. Which of the solutions could be neutral?
    - Colourless in curry powder
    - Red in red cabbage
    - Green in radish
    - Purple in blueberries
- Using the general reactions as a guide, write balanced equations for the reactants given below.
  - $\text{HNO}_3(\text{aq}) + \text{Ba}(\text{OH})_2(\text{aq}) \rightarrow$
  - $\text{HCl}(\text{aq}) + \text{Al}(\text{OH})_3(\text{s}) \rightarrow$
  - $\text{H}_2\text{SO}_4(\text{aq}) + \text{Mg}(\text{s}) \rightarrow$
  - $\text{CH}_3\text{COOH}(\text{aq}) + \text{MgCO}_3(\text{s}) \rightarrow$
  - $\text{H}_3\text{PO}_4(\text{aq}) + \text{NaHCO}_3(\text{s}) \rightarrow$
- A solution was thought to contain either sodium hydroxide or calcium carbonate. Describe what test/s could be carried out to correctly identify the substance.
- In a well-insulated calorimeter, 25 mL of  $0.412 \text{ mol L}^{-1}$  sodium hydroxide solution was added to 50 mL of  $0.206 \text{ mol L}^{-1}$  nitric acid solution. The two solutions were at the same initial temperature. The maximum temperature rise for the reaction was  $1.77^\circ\text{C}$ . Calculate the enthalpy of neutralisation for the reaction.
- If 500 mL of a  $2 \text{ mol L}^{-1}$  solution of HCl reacts with 500 mL of a  $2 \text{ mol L}^{-1}$  solution of NaOH to produce a temperature rise of  $14^\circ\text{C}$ , what is the heat of neutralisation, assuming there is no heat lost during the reaction.
- Explain why neutralisation is an important reaction in maintaining healthy teeth.
- Write a paragraph justifying the application of neutralisation reactions in industry.
- Evaluate the accuracy of the statement: 'Indicators can undergo reversible reactions in the presence of acids and bases'. Use an example to support your case.

**TABLE 5.1** Natural indicators and their acidity/alkalinity ranges

INDICATOR	HIGHLY ACIDIC	SLIGHTLY ACIDIC	NEUTRAL	SLIGHTLY ALKALINE	HIGHLY ALKALINE
Raddish	orange	pink	green	green	green
Blueberries	red	purple	green	green	green
Red cabbage	red	pink	purple	blue	green
Curry powder	colourless	colourless	colourless	yellow	red



- 14** Data tables give a theoretical value for enthalpy changes of neutralisation for reactions of  $-57 \text{ kJ mol}^{-1}$  irrespective of the strong acid or strong base used. Explain how this value can be independent of the acids and bases involved in the reaction.
- 15** Using a flow chart, show how theories of acids and bases have changed over time.
- 16** Compare Arrhenius theory of acids and bases with that of Brønsted–Lowry, identifying how limitations of the Arrhenius theory were addressed.
- 17** Carbonates are bases. The early definitions of bases could not account for the behaviour of carbonates but the Brønsted–Lowry definition can. Explain why.
- 18** Explain why the Brønsted–Lowry theory of acids and bases is still widely used despite its limitations.

## 6

## Using Brønsted–Lowry theory

## INQUIRY QUESTION

How can the position of equilibrium be described and what does the equilibrium constant represent?

## INQUIRY QUESTION

What is the role of water in solutions of acids and bases?

## INQUIRY QUESTION

How are solutions of acids and bases analysed?

## Students:

conduct a practical investigation to measure the pH of a range of acids and bases

calculate  $p$ ,  $pO$ , hydrogen ion concentration ( $[H^+]$ ) and hydroxide ion concentration ( $[OH^-]$ ) for a range of solutions ACSCH10) ICT N

conduct an investigation to demonstrate the use of pH to indicate the differences between the strength of acids and bases ACSCH10)

write ionic equations to represent the dissociation of acids and bases in water, conjugate acid/base pairs in solution and amphiprotic nature of some salts, for example:

- sodium hydrogen carbonate
- potassium dihydrogen phosphate

construct models and/or animations to communicate the differences between strong, weak, concentrated and dilute acids and bases ACSCH09) ICT

calculate the pH of the resultant solution when solutions of acids and/or bases are diluted or mixed ICT N

explore the use of  $K_a$  for different types of chemical reactions, including but not limited to:

- dissociation of acids and bases ACSCH09, ACSCH99) \*

- model neutralisation of strong and weak acids and bases using a variety of media ICT

calculate and apply the dissociation constant ( $K_a$ ) and  $pK_a$  ( $pK_a = -\log_{10}(K_a)$ ) to determine the difference between strong and weak acids. ACSCH09) ICT N

\*from Module 5

Chemistry Stage 6 Syllabus © NSW Educational Standards Authority for and on behalf of the Crown in right of the State of New South Wales, 2017





The majority of solutions found naturally on Earth are aqueous solutions. A tremendous amount of chemistry occurs in these aqueous solutions. Water is often referred to as the universal solvent because it dissolves both organic materials, such as enzymes and amino acids, and inorganic materials, such as salts and minerals.

Water is an essential component in the definitions of both acids and bases.

Water ( $\text{H}_2\text{O}$ ) plays a key role in many different chemical reactions. In fact, there is a particular type of chemical reaction called hydrolysis in which water is used to break down the bonds of a particular substance. The word 'hydrolysis' comes from the Greek in which 'hydro' means water and 'lysis' means to unbind.

The most common type of hydrolysis occurs when water ionises into hydroxide ions ( $\text{OH}^-$ ) and hydronium cations ( $\text{H}_3\text{O}^+$ ). According to Brønsted–Lowry theory, water can act as both an acid and a base so is an important component in reactions of these compounds.



FIGURE 6.1 Water is the most common solvent in nature.

## 6.1 Brønsted–Lowry revisited

As you learnt in chapter 5, the Brønsted–Lowry theory of acids and bases is broader than the Arrhenius definition:

- ▶ An acid is a substance that donates one or more protons or hydrogen ions ( $\text{H}^+$ ).
- ▶ A base is defined as a substance that accepts one or more protons.

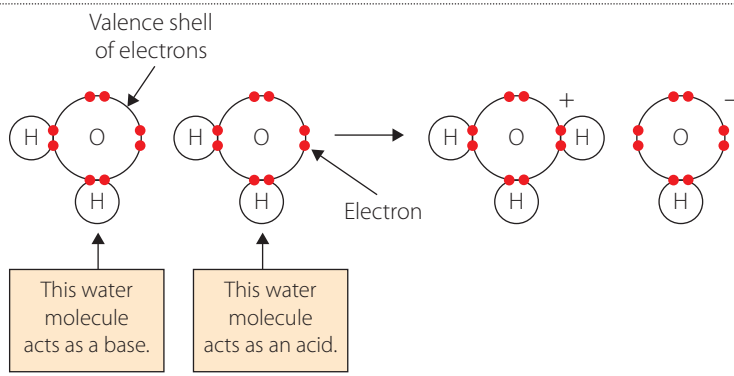
As you learnt in chapter 5, a substance that can act as an acid or base is called amphoteric. It is able to accept or donate a proton. This is illustrated in Figure 6.2.

Amphoteric substances were discussed in section 5.2 page 124. You may like to revisit this section.



Prior knowledge

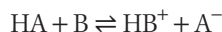
**FIGURE 6.2** The amphoteric nature of water. Water can act as an acid and as a base. Which one it acts as depends on what other species is present.



The Brønsted–Lowry definitions of an acid as a proton donor and a base as a proton acceptor meant that bases became the mirror companion of acids (as merely simple receptors). The measurement of hydronium ion concentration became key to defining the degree of acidity.

## Mirror companions and conjugate pairs

The Brønsted–Lowry definition of a base as the mere receptor of a proton allows the reactions of acids to be generalised. The reactions can be considered reversible, as shown in the following equation where HA denotes an acid molecule and B denotes a base molecule:



For the forward reaction, HA is an acid because it is donating a proton to the base, B. The base accepts a proton from HA. The reverse reaction is between the  $\text{HB}^+$  ion and the  $\text{A}^-$  ion. In the reverse reaction,  $\text{HB}^+$  is the acid because it is donating a proton to the  $\text{A}^-$  ion. The  $\text{A}^-$  ion is a base that accepts a proton from the  $\text{HB}^+$ .

The acid (HA) on the left produces a base ( $\text{A}^-$ ) when it loses a proton ( $\text{H}^+$ ). The base (B) on the left produces an acid ( $\text{HB}^+$ ) when it accepts a proton. These acid–base pairs are called **conjugate pairs**. Figure 6.3 shows the pairs diagrammatically.

Members of a conjugate acid–base pair differ from each other by the presence or absence of the transferable  $\text{H}^+$  (hydrogen ion).

The example here shows the acid HCl donating a proton to form its **conjugate base**,  $\text{Cl}^-$ . Water is accepting the proton so acts as the base and forms its **conjugate acid**,  $\text{H}_3\text{O}^+$  (Figure 6.4).

Conjugate pairs can be identified in any acid–base reaction. This can be seen in the reaction between sulfuric acid ( $\text{H}_2\text{SO}_4$ ) and ammonia ( $\text{NH}_3$ ) shown in Figure 6.5.

- An acid is a substance that donates one or more protons or hydrogen ions ( $\text{H}^+$ ).
- A base is defined as a substance that accepts one or more protons.
- Members of a conjugate acid–base pair differ from each other by the presence or absence of the transferable  $\text{H}^+$  (hydrogen ion).

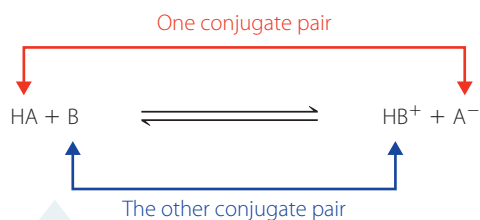


FIGURE 6.3 Conjugate acid–base pairs

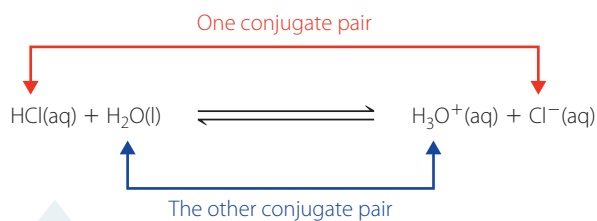


FIGURE 6.4 Conjugate acid–base pairs

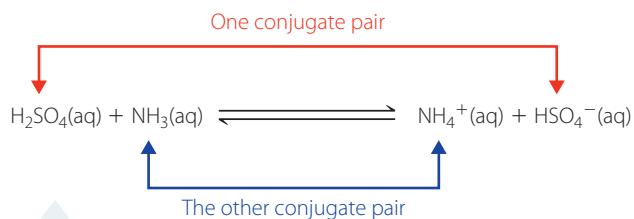


FIGURE 6.5 Conjugate acid–base pairs

- 1 Use an example to explain what is meant by conjugate pairs.
- 2 What is the difference between a conjugate acid and a conjugate base?
- 3 Define 'amphiprotic'.
- 4 Identify the two conjugate acid–base pairs in each of the following equations.
  - a  $\text{HNO}_3(\text{aq}) + \text{H}_2\text{O}(\text{l}) \rightleftharpoons \text{H}_3\text{O}^+(\text{aq}) + \text{NO}_3^-(\text{aq})$
  - b  $\text{NH}_4^+(\text{aq}) + \text{H}_2\text{O}(\text{l}) \rightleftharpoons \text{H}_3\text{O}^+(\text{aq}) + \text{NH}_3(\text{aq})$
  - c  $\text{HSO}_4^-(\text{aq}) + \text{O}^{2-}(\text{aq}) \rightleftharpoons \text{SO}_4^{2-}(\text{aq}) + \text{OH}^-(\text{aq})$
  - d  $\text{H}_2\text{PO}_4^-(\text{aq}) + \text{CO}_3^{2-}(\text{aq}) \rightleftharpoons \text{HPO}_4^{2-}(\text{aq}) + \text{HCO}_3^-(\text{aq})$
  - e  $\text{HC}_2\text{H}_3\text{O}_2(\text{aq}) + \text{HS}^-(\text{aq}) \rightleftharpoons \text{C}_2\text{H}_3\text{O}_2^-(\text{aq}) + \text{H}_2\text{S}(\text{aq})$

CHECK YOUR UNDERSTANDING

6.1





- 5 Write a reaction showing how water can act as both an acid and base. Identify the acid base pairs in the reaction.
- 6 Write the conjugate acids of the following bases.
  - a  $\text{HCO}_3^-$
  - b  $\text{OH}^-$
  - c  $\text{HPO}_4^{2-}$
- 7 Write the conjugate bases of the following acids.
  - a  $\text{H}_2\text{CO}_3$
  - b  $\text{HOCN}$
  - c  $\text{HPO}_4^{2-}$
- 8 The equation for the reaction between a solution of ammonium chloride and a solution of sodium hydroxide is:



Which substance is acting as an acid and which is acting as a base? Explain your reasoning.

- 9 Carbonates are bases. The earlier definitions could not account for the behaviour of carbonates as bases but the Brønsted–Lowry definition can. Explain why.

## 6.2 The pH scale

In chapter 5 you used natural indicators to determine whether a substance was acidic or alkaline. Indicators are commonly used every day to measure acidity and alkalinity in soil and water, such as swimming pools, as well as to monitor waste from industries, laboratories and sewage treatment plants.

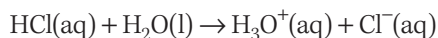


**FIGURE 6.6** Checking the approximate pH of soil using an indicator colour chart

An indicator can also be used to provide information on the degree of acidity or alkalinity of a solution. However, because chemists need more precise measures of the degree of acidity and alkalinity of solutions, they have developed a scale to quantitatively measure the acidity of a solution. This is called the **pH scale**.

The term 'pH' stands for 'hydrogen power'. This name came about because the scale is based on the concentration of hydrogen ions in solution. Remember that in aqueous solutions the hydrogen ion attaches to a water molecule to form the hydronium ion ( $\text{H}_3\text{O}^+$ ). Therefore, it is also based on the concentration of hydronium ions. Danish biochemist Soren Sorensen devised the scale to make writing the hydrogen ion concentration in solution more manageable.

The pH scale also reflects the importance of the Brønsted–Lowry definition of an acid as a proton donor. This is because the pH scale is a measurement of the number of hydronium ions present in a solution (that is, the number of  $\text{H}^+$  ions the acid has donated to water to form the hydronium ion). For example:





The pH scale generally goes from 0 to 14, although there are also values outside this range. The lower the pH, the more acidic a solution is; the higher the pH, the more basic the solution is. Therefore, at 25°C, acids have a pH of less than 7 and bases have a pH greater than 7. A substance that has a pH equal to 7 is neutral.

Table 6.1 shows the relationship between pH and hydrogen ion concentration.

**TABLE 6.1 pH and hydrogen ion concentration**

pH	0	1	2	3	4	5	6	7	8	9	10	11	12	13	14
H <sup>+</sup> (or H <sub>3</sub> O <sup>+</sup> ) concentration mol L <sup>-1</sup>	1	1 × 10 <sup>-1</sup> or 0.1	1 × 10 <sup>-2</sup>	1 × 10 <sup>-3</sup>	1 × 10 <sup>-4</sup>	1 × 10 <sup>-5</sup>	1 × 10 <sup>-6</sup>	1 × 10 <sup>-7</sup>	1 × 10 <sup>-8</sup>	1 × 10 <sup>-9</sup>	1 × 10 <sup>-10</sup>	1 × 10 <sup>-11</sup>	1 × 10 <sup>-12</sup>	1 × 10 <sup>-13</sup>	1 × 10 <sup>-14</sup>

Notice the relationship between the pH value and the number (ignoring the negative sign) of the base 10 superscript in the hydrogen ion concentration. They are the same number because pH is based on the hydrogen ion concentration of a solution.

An important aspect of the pH scale to note is that an increase in 1 unit on the scale is equal to a 10 times decrease in the hydrogen ion concentration. For example, a change from pH1 to pH2 is equivalent to a change in the hydrogen ion concentration from 0.1 to 0.01 mol L<sup>-1</sup>.

The pH of a solution is defined as:

$$\text{pH} = -\log_{10}[\text{H}^+]$$

While the pH scale is based on the hydrogen ion concentration it can also be used to determine the alkalinity and therefore the hydroxide ion (OH<sup>-</sup>) concentration. A pH of 7 represents a neutral solution. At pH 7 the concentration of H<sup>+</sup> is 10<sup>-7</sup> mol L<sup>-1</sup>, so the concentration of OH<sup>-</sup> must also be 10<sup>-7</sup> mol L<sup>-1</sup>.

Table 6.2 includes the concentration of OH<sup>-</sup> ions compared to pH.

**TABLE 6.2 pH and OH<sup>-</sup> ion concentration**

pH	0	1	2	3	4	5	6	7	8	9	10	11	12	13	14
H <sup>+</sup> (H <sub>3</sub> O <sup>+</sup> ) concentration mol L <sup>-1</sup>	1 or 10 <sup>0</sup>	10 <sup>-1</sup> or 0.1	10 <sup>-2</sup>	10 <sup>-3</sup>	10 <sup>-4</sup>	10 <sup>-5</sup>	10 <sup>-6</sup>	10 <sup>-7</sup>	10 <sup>-8</sup>	10 <sup>-9</sup>	10 <sup>-10</sup>	10 <sup>-11</sup>	10 <sup>-12</sup>	10 <sup>-13</sup>	10 <sup>-14</sup>
OH <sup>-</sup> concentration mol L <sup>-1</sup>	10 <sup>-14</sup>	10 <sup>-13</sup>	10 <sup>-12</sup>	10 <sup>-11</sup>	10 <sup>-10</sup>	10 <sup>-9</sup>	10 <sup>-8</sup>	10 <sup>-7</sup>	10 <sup>-6</sup>	10 <sup>-5</sup>	10 <sup>-4</sup>	10 <sup>-3</sup>	10 <sup>-2</sup>	10 <sup>-1</sup>	10 <sup>0</sup>

As can be seen in Table 6.2, there is a relationship between the concentration of the H<sup>+</sup> ion and the concentration of the OH<sup>-</sup> ion. You should notice that:

- as the H<sup>+</sup> ion concentration goes down, the OH<sup>-</sup> ion concentration goes up by the corresponding number
- adding the numbers in the concentration superscripts (ignoring the negative sign) always results in 14.

## Measuring pH

There are many ways of measuring pH, such as indicators, as well as pH meters and pH probes that give a digital readout of the pH of a solution. A pH probe is shown in Figure 6.7 (page 148).

The concentration of H<sup>+</sup> has been written in exponential notation since that is a better way of representing the numbers involved.

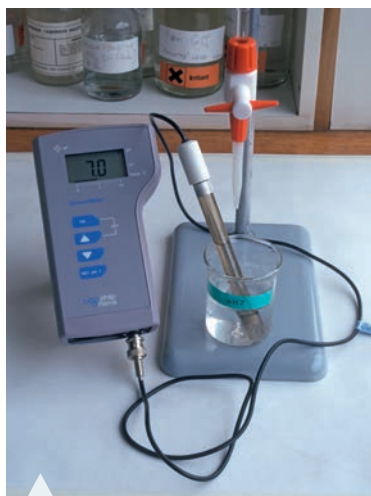
The square brackets around a species mean 'molar concentration of,' so [H<sup>+</sup>] is read as the molar concentration of hydrogen ions.



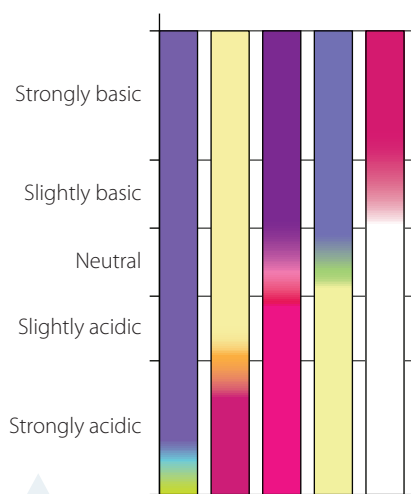
### pH scale and concentrations

A virtual lab that shows the relationship between the pH scale and acid and base concentrations





**FIGURE 6.7** A pH probe



**FIGURE 6.8** Colour changes in a range of indicators

In chapter 5 you used natural indicators to determine whether a solution is acidic or alkaline; however, there are also synthetic indicators that can be used as well. The synthetic indicators also provide a quantitative measurement for the degree of acidity. Some synthetic indicators are methyl violet, methyl orange, litmus, bromothymol blue and phenolphthalein. The colour changes can be seen in Figure 6.8, which shows the actual range of acidity or alkalinity over which an indicator changes colour varies between indicators.

Chemists have also developed a **universal indicator** that produces several colour changes depending on the pH of the solution. It is a mixture of several indicators.

**TABLE 6.3** pH of some common substances

COLOUR OF UNIVERSAL INDICATOR	$[H_3O^+]$	pH	SUBSTANCE	
Red	10	-1	Concentrated hydrochloric acid	ACID
	1	0	Car batter acid 1 mol L <sup>-1</sup> hydrochloric acid	
	10 <sup>-1</sup>	1	0.1 mol L <sup>-1</sup> hydrochloric acid	
	10 <sup>-2</sup>	2	Stomach acid	
	10 <sup>-3</sup>	3	Vinegar Lemon juice	
	10 <sup>-4</sup>	4	Soft drinks Soda water	
Yellow	10 <sup>-5</sup>	5	Wine Black coffee	
	10 <sup>-6</sup>	6	Rain water Milk, saliva	
Green	10 <sup>-7</sup>	7	Very pure water	NEUTRAL
Blue	10 <sup>-8</sup>	8	Blood Sea water	ALKALINE
	10 <sup>-9</sup>	9	Bore water Baking soda solution	
	10 <sup>-10</sup>	10	Toilet soap	
	10 <sup>-11</sup>	11	Laundry detergents	
	10 <sup>-12</sup>	12	Household ammonia Dishwashing machine powders	
	10 <sup>-13</sup>	13	Chlorine bleach solutions	
10 <sup>-14</sup>	14	Oven cleaners 1.0 mol L <sup>-1</sup> sodium hydroxide		



pH and indicators

# INVESTIGATION 6.1

## Measuring pH

### INTRODUCTION

By measuring the pH of various substances, you can determine how acidic or basic they are. In this investigation you will be able to determine the actual pH of these substances using universal indicator and a pH meter. An advantage of using a pH meter is that it does not involve adding any additional substances to the solution and the pH can usually be found with a greater degree of accuracy, provided the meter is calibrated correctly.

### AIM

To measure and compare the pH of various substances.

### MATERIALS

- Various household substances (for example, vinegar, lemon juice, dishwasher detergent, shampoo, antacid tablet, baking soda, vitamin C, bleach, washing detergent, fabric conditioner, soda water, salt, sugar)
- Soil samples (including potting mix)
- Samples of water from swimming pools and local waterways
- 1 mol L<sup>-1</sup> and 0.0001 mol L<sup>-1</sup> hydrochloric acid (HCl)
- 1 mol L<sup>-1</sup> and 0.0001 mol L<sup>-1</sup> sodium hydroxide (NaOH)
- Barium sulfate (BaSO<sub>4</sub>) powder
- Universal indicator solution and pH colour chart
- Distilled water
- Petri dishes (one for each soil sample)
- Test tubes and test-tube rack
- pH meter or pH probe
- Spatula
- Filter funnel and paper
- Gloves
- Safety glasses

WHAT ARE THE RISKS IN DOING THIS INVESTIGATION?	HOW CAN YOU MANAGE THESE RISKS TO STAY SAFE?
Household chemicals can burn the skin.	Wear safety glasses and protective clothing. Take care when handling the chemicals and tell the teacher if there is a spill.
Sodium hydroxide is caustic and hydrochloric acid is corrosive.	Wear safety glasses and personal protective clothing, avoid contact with skin. If spilt on skin, wash with plenty of water.
Food products can be contaminated in the laboratory.	Do not eat or drink any food used in the laboratory.
Soil samples may contain harmful micro-organisms.	Do not touch the soil sample. Work in a well-ventilated area. Wash your hands at the end of the experiment.



What other risks are associated with your investigation? How can you manage these?

### METHOD

#### PART A: TESTING HOUSEHOLD SUBSTANCES, HYDROCHLORIC ACID AND SODIUM HYDROXIDE SOLUTIONS

- 1 Set up test tubes in the rack. Place a few millilitres (enough to allow measurement using the pH meter) of the substance to be tested in a test tube. (You may need to add distilled water if the substance is a solid.)
- 2 Test the pH with the pH meter.
- 3 Record the pH.
- 4 Rinse the pH meter with distilled water.
- 5 Add one drop of universal indicator solution.



- » 6 Record the colour and pH.
- 7 Repeat with all other household substances, hydrochloric acid and sodium hydroxide solutions.

#### PART B: TESTING WATER SAMPLES

- 1 If the samples contain a lot of suspended sediment, filter or allow them to settle before testing.
- 2 Repeat the method used in part A to test the samples.

#### PART C: TESTING SOIL SAMPLES

- 1 Place approximately a spatula of soil in a Petri dish.
- 2 Add a few drops of indicator to make a paste and stir it.
- 3 Lightly sprinkle a thin layer of barium sulfate powder over the soil paste. Do not stir.
- 4 Allow a few minutes for the powder to absorb the indicator. Record the colour and pH values.
- 5 Repeat steps 1–4 with other soil samples.

#### RESULTS

Record your results in a table. Include an additional column for hydrogen ion concentration.

#### ANALYSIS OF RESULTS

- 1 List the substances from the most acidic to the most basic.
- 2 Record which substances, if any, were neutral.

#### DISCUSSION

- 1 Identify where there were significant differences between the pH values obtained using universal indicator and the pH meter. Suggest possible reasons for these differences
- 2 Suggest a procedure for measuring the pH of the soil samples using a pH meter.
- 3 Identify any noticeable difference in the pH of the water samples and suggest a reason for this difference.
- 4 Compare the hydrogen ion concentration of the samples of HCl used with the pH reading obtained from the meter. Suggest what the difference in these readings could imply.
- 5 Use Table 6.2 (page 147) to determine the hydroxide ion concentration of the sodium hydroxide samples from the pH measured. Compare the value obtained from the pH meter with that of the solutions. Suggest possible reasons for any differences.
- 6 Reflect on possible errors that could have occurred and suggest what effect these may have had on the results.

#### CONCLUSION

Identify any generalisations related to the acidity and alkalinity of the substances tested.



Information and communication technology capability



#### Determination of pH

Run a virtual lab that shows how to determine pH using indicators.

When determining the significant figures in pH values, only the mantissa (the digits after the decimal place) is significant; for example, a pH of 3.14 has only two significant figures. The '3' is called the characteristic and is a 'place holder'.

### Calculating pH

It is relatively straightforward to work out the pH when the concentration is 0.1 or 0.01, or any factor of 10 using the relationship  $\text{pH} = -\log_{10}[\text{H}^+]$ :

- for a solution in which  $[\text{H}^+] = 0.1 \text{ M}$  (or  $1 \times 10^{-1}$ ), the pH is 1.0
- for a solution in which  $[\text{H}^+] = 0.01 \text{ M}$  (or  $1 \times 10^{-2}$ ), the pH is 2.0
- for a solution in which  $[\text{H}^+] = 0.0000001 \text{ M}$  (or  $1 \times 10^{-7}$ ), the pH is 7.0.

Notice that  $[\text{H}^+] = 10^{-\text{pH}}$ .

However, when the concentration is 0.015, which is between 0.1 and 0.01, you need a calculator.

Worked example 6.1 shows how to calculate pH and  $[\text{H}^+]$  when the values are more complex.

**WORKED EXAMPLE** (6.1)

- 1 Calculate pH, given  $[H^+] = 2.0 \times 10^{-5} \text{ M}$ .
- 2 Calculate  $[H^+]$  when  $\text{pH} = 8.5$ .

ANSWER	LOGIC
$\text{pH} = -\log_{10}[H^+]$ $\text{pH} = -\log_{10}(2.0 \times 10^{-5})$ 1 $\text{pH} = 4.70$	<ul style="list-style-type: none"> <li>Choose correct formula and insert numbers.</li> </ul>
$[H^+] = 10^{-\text{pH}}$ $[H^+] = 10^{-8.5}$ 2 $[H^+] = 3.2 \times 10^{-9} \text{ M}$	<ul style="list-style-type: none"> <li>Choose correct formula and insert numbers.</li> </ul>

**TRY THESE YOURSELF**

- 1 Determine the pH of a solution, given  $[H^+] = 0.001 \text{ M}$ .
- 2 Determine the pH of a solution, given  $[H^+] = 1.2 \times 10^{-5} \text{ M}$ .
- 3 Calculate  $[H^+]$  when the pH of the solution is 6.
- 4 Calculate  $[H^+]$  when the pH of the solution is 11.7.

- The pH scale, which is based on the concentration of hydrogen ions in a solution, provides a quantitative measure of acidity and alkalinity.
- The pH of a solution is defined as the negative logarithm (to the base 10) of the hydrogen ion concentration:  

$$\text{pH} = -\log_{10}[H^+]$$
- Universal indicator produces several colour changes depending on the pH of the solution.

- 1 Define 'pH'.
- 2 Explain what information the pH scale provides.
- 3 **a** Explain the difference between a hydrogen ion and hydronium ion.  
**b** Describe the relationship between pH, concentration of hydrogen ion and concentration of hydronium ion.
- 4 Describe the purpose of universal indicator.
- 5 **a** Explain the relationship between concentration of an acid, concentration of a base and pH.  
**b** At which pH are there equal concentrations of hydrogen and hydroxide ions?
- 6 Look at the following pH values.
 

<ul style="list-style-type: none"> <li>pH 1–3</li> <li>pH 4–6</li> <li>pH 7</li> </ul>	<ul style="list-style-type: none"> <li>pH 8–10</li> <li>pH 11–13</li> </ul>
--	---

Which pH range would apply to each of the following solutions?

- Concentrated hydrochloric acid
- Distilled water
- Dilute sodium hydroxide
- Dishwasher detergent

**CHECK YOUR UNDERSTANDING**

6.2





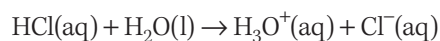
- 7 Compare and contrast two different ways of measuring pH, stating positives and negatives for each method.
- 8 a Determine the pH of a solution, given  $[H^+] = 0.01 \text{ mol L}^{-1}$ .  
b Determine the pH of a solution, given  $[H^+] = 0.0175 \text{ mol L}^{-1}$ .
- 9 a Calculate  $[H^+]$  when the pH of the solution is 3.  
b Calculate  $[H^+]$  when the pH of the solution is 10.4

## 6.3 Concentration versus strength of acids and bases

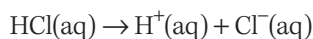
The terms 'concentration' and 'strength' may be interchanged in general use; however, to the chemist these terms have quite different meanings.

As you learnt in chapter 5, acids and bases react with water to produce hydronium and hydroxide ions.

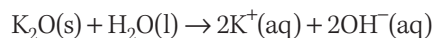
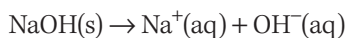
The reaction of the acid with water is called an **ionisation reaction** since ions are formed. When an acid ionises, it produces hydronium ions ( $H_3O^+$ ) in aqueous solution, although this is often simplified to  $H^+$ . For example:



or



When a base dissolves in water, it forms separate ions. This reaction is called a **dissociation reaction**. A base usually dissociates to produce hydroxide ions in aqueous solution. For example:



### Understanding concentration

Molarity was explained in *Chemistry in Focus Year 11* in section 8.4 page 181. You might wish to revisit this.

You will recall from *Chemistry in Focus Year 11* in chapter 8 that the definitions of 'concentrated' and 'dilute' relate to the amount of solute in a specified amount of solution. There are many different ways of representing concentration; however, the most convenient measure of concentration used in chemistry is **molarity**, which is measured in moles per litre, and represented as  $\text{mol L}^{-1}$  or M.

- A concentrated solution is one in which the total concentration is high (for example, 4 M or  $4 \text{ mol L}^{-1}$ ).
- A dilute solution is one in which the total concentration is low (for example, less than 2 M or  $2 \text{ mol L}^{-1}$ ).

### Understanding strength of acids and bases

The degree to which an acid ionises or a base dissociates gives a measure of the strength of that acid or base. This can be determined by measuring the pH of the aqueous solution of the same concentration.

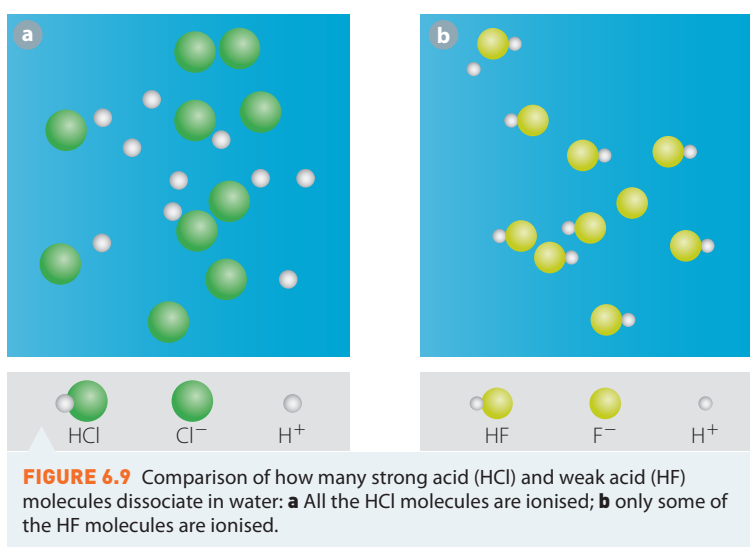
Acids in which almost all of the acid molecules ionise to produce a hydrogen ion are defined as **strong acids**. Examples of strong acids are hydrochloric acid (HCl), nitric acid ( $HNO_3$ ) and sulfuric acid ( $H_2SO_4$ ). Acids in which only some of the molecules ionise are defined as weak acids. Examples of weak acids are acetic acid ( $CH_3COOH$ ) and carbonic acid ( $H_2CO_3$ ).

Bases can be similarly defined as strong or weak depending on the number of molecules or ionic compounds that dissociate in aqueous solution. A **strong base** is one in which almost all the species have dissociated. Examples of strong bases are sodium hydroxide (NaOH) and potassium hydroxide (KOH). Bases in which only a small proportion of the species produce hydroxide ions in aqueous solution are defined as weak bases. Examples of weak bases are ammonia (NH<sub>3</sub>) and methylamine (CH<sub>3</sub>NH<sub>2</sub>) Table 6.4 provides examples of acids and bases.

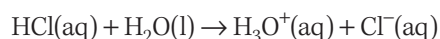
**TABLE 6.4** Examples of acids and bases in aqueous solution

STRONG ACIDS	STRONG BASES
Hydrochloric acid, HCl Nitric acid, HNO <sub>3</sub> Sulfuric acid, H <sub>2</sub> SO <sub>4</sub>	Sodium hydroxide, NaOH Potassium hydroxide, KOH Barium hydroxide, Ba(OH) <sub>2</sub> Sodium oxide, Na <sub>2</sub> O
WEAK ACIDS	WEAK BASES
Ethanoic acid, CH <sub>3</sub> COOH Carbonic acid, H <sub>2</sub> CO <sub>3</sub> Hydrofluoric acid, HF Citric acid, C <sub>6</sub> H <sub>8</sub> O <sub>7</sub>	Ammonia, NH <sub>3</sub> Methylamine, CH <sub>3</sub> NH <sub>2</sub>

The strength of an acid or base is determined by the proportion of molecules that have ionised or dissociated.

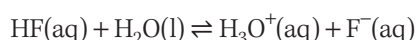


In an aqueous solution of a strong acid, as shown in Figure 6.9a, all the molecules are ionised so the reaction has gone to completion and is written:



However, in an aqueous solution of a weak acid, shown in Figure 6.9b, only some of the molecules are ionised. The solution represents an equilibrium situation with weak acid molecules and the ions produced from the ionisation. Therefore, when writing the ionisation for weak acids and bases, the equilibrium arrow representation should be used.

For example, the ionisation of the weak acid HF should be written as:





## Comparing concentration and strength

If the concentrations of a strong acid solution and a weak acid solution are the same, the concentration of hydronium ions  $[\text{H}_3\text{O}^+]$  is higher in the strong acid solution than in the weak acid solution. This is because while almost all the molecules of strong acids ionise, only a small proportion of the molecules of weak acid ionise; therefore, there is a lower concentration of hydronium ions in aqueous solution of a weak acid. This also means that when the concentrations of solutions of a strong acid and weak acid are the same, the resulting pH of the strong acid solution will be lower than the pH of the weak acid. This is because pH is a measure of hydronium ion concentration and the strong acid solution will have more hydronium ions than the weak acid solution.

A similar trend exists for strong and weak base solutions of the same concentration. A strong base will completely dissociate to produce a high concentration of hydroxide ions  $[\text{OH}^-]$ , while a weak base produces a much lower concentration of hydroxide ions  $[\text{OH}^-]$  due to fewer particles dissociating.

## INVESTIGATION 6.2

### Comparing the pH of solutions of strong and weak acids and bases

#### INTRODUCTION

The acidity or alkalinity of a solution can be expressed in terms of pH or the concentration of  $\text{H}^+$  ions present, while the concentration of a solution is expressed in  $\text{mol L}^{-1}$ . Solutions of the same concentration of acids (or alkalis) may not have the same pH since this is dependent on the proportion of the acid or base that produces  $\text{H}^+$  ions or  $\text{OH}^-$  ions in solution.

#### AIM

To compare the pH of different solutions of acids and bases.

#### MATERIALS

- 50 mL  $0.1 \text{ mol L}^{-1}$  and  $0.01 \text{ mol L}^{-1}$  hydrochloric acid (HCl)
- 50 mL  $0.1 \text{ mol L}^{-1}$  acetic acid ( $\text{CH}_3\text{COOH}$ )
- 50 mL  $0.1 \text{ mol L}^{-1}$  and  $0.01 \text{ mol L}^{-1}$  sodium hydroxide (NaOH)
- 50 mL  $0.1 \text{ mol L}^{-1}$  ammonium hydroxide solution ( $\text{NH}_4\text{OH}$ )
- Distilled water
- 8 × 50 mL beakers
- 25 mL measuring cylinder
- pH meter or pH probe
- Safety glasses



#### WHAT ARE THE RISKS IN DOING THIS INVESTIGATION?

Sodium hydroxide is caustic and hydrochloric acid is corrosive.

#### HOW CAN YOU MANAGE THESE RISKS TO STAY SAFE?

Wear safety glasses and personal protective clothing, avoid contact with skin. If spilt on skin, wash with plenty of water.

What other risks are associated with your investigation? How can you manage these? »»

## » METHOD

### PART A: COMPARING pH OF SOLUTIONS OF THE SAME CONCENTRATION

- 1 Place 25 mL (enough to allow measurement using the pH meter or probe) of the  $0.1 \text{ mol L}^{-1}$  hydrochloric acid in a clean beaker.
- 2 Test the pH with the pH meter or probe.
- 3 Record the pH.
- 4 Rinse the pH meter with distilled water.
- 5 Repeat steps 1–4 with all other solutions of  $0.1 \text{ mol L}^{-1}$  concentration.

### PART B: COMPARING SOLUTIONS OF DIFFERENT CONCENTRATIONS

- 1 Place 25 mL (enough to allow measurement using the pH meter or probe) of the  $0.01 \text{ mol L}^{-1}$  hydrochloric acid in a clean beaker.
- 2 Test the pH with the pH meter or probe.
- 3 Record the pH.
- 4 Rinse the pH meter with distilled water.
- 5 Repeat steps 1–4 with NaOH solutions.

## RESULTS

Record your results in a table. Include an additional column for hydrogen ion/hydroxide ion concentration.

## ANALYSIS OF RESULTS

- 1 Use the pH to determine the  $[\text{H}^+]$  for each sample.
- 2 Use Table 6.2 (page 147) to determine the approximate hydroxide ion concentration of the sodium hydroxide and ammonium hydroxide samples.

## DISCUSSION

- 1 Compare the pH of the two different concentrations of the HCl. Suggest why the pH of the two concentrations is different.
- 2 Compare the  $[\text{OH}^-]$  of the two different concentrations of NaOH. Suggest why these concentrations are different.
- 3 Write a generalisation for the relationship between pH and concentration.
- 4 Compare the pH of  $0.1 \text{ mol L}^{-1}$  concentrations of hydrochloric and acetic acids. Which acid has the lower pH?
- 5 Suggest why the pH and  $[\text{H}^+]$  of the two acids are different even though the concentrations are the same.
- 6 Conduct a similar comparison for the two bases, remembering that the larger the pH the more basic the solution is.
- 7 Decide which acid and base you would classify as stronger and which acid and base you would classify as weaker. Explain how you decided this.

## CONCLUSION

Identify the relationship between pH and strength of acids and bases of the same concentration. Identify the relationship between pH and concentration of the same acid or base.

## EXTENSION

Calculate the degree of ionisation of the weak acid using the formula:

$$\text{Fraction ionised} = \frac{[\text{H}^+]}{\text{Total concentration of acid in solution}}$$



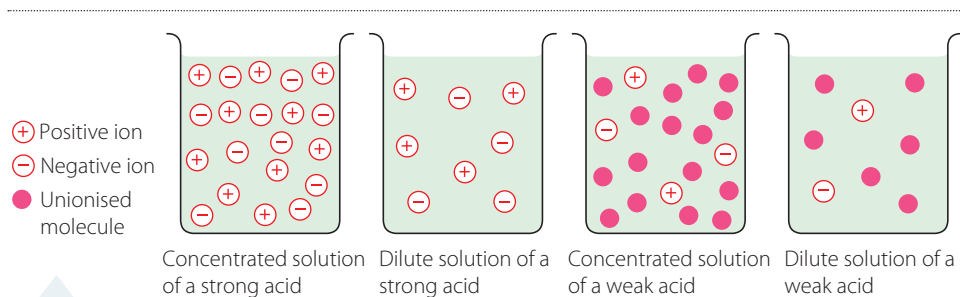
Strong, weak, concentrated and dilute



### Visiuing strength vs concentration

This simulation allows you to vary strength and concentration of acids and bases.

It is possible to have a dilute solution of a strong acid and a concentrated solution of a weak acid. This is also true of strong and weak bases. 'Concentrated', 'dilute', 'strong' and 'weak' have independent meanings in chemistry, as shown in Figure 6.10.



**FIGURE 6.10** Concentrated and dilute solutions of a weak and strong acid

## INVESTIGATION 6.3

### Modelling strength versus concentration of acids and bases

#### INTRODUCTION

In chemistry, the terms 'strength' and 'concentration' have very different meanings. Equal concentrations of acids or bases may not have the same pH because the acids or bases may dissociate to different extents depending on their strengths.

In this activity you are to construct a model or animation to communicate a chemistry understanding of the difference between strength and concentration.

#### AIM

To construct models or animations to communicate the differences between strong, weak, concentrated and dilute acids and bases.

#### METHOD

- 1 Refer to Figure 6.10 – this shows diagrammatically the difference between strong, weak, concentrated and dilute acids.
- 2 Decide whether to construct physical models or animations.
- 3 If constructing physical models, list what materials will be needed to produce molecular models of the acids and bases being represented. For example, molecular model kits, polystyrene balls of different size and colour, and toothpicks to join them.
- 4 For ideas about modelling, view the video in the relevant weblink.
- 5 If producing an animation, decide what software is available.
- 6 For ideas about making animations, view the video in the relevant weblink.

#### DISCUSSION

- 1 Explain how your model/animation shows different strengths of acids and bases.
- 2 Describe how your model/animation shows different concentrations.
- 3 Justify how your model shows a comparison between strength and concentration.



Selecting information from grids to support a claim



Information and communication technology capability



Modelling ionisation



Acid animation

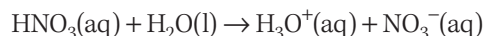
## Polyprotic acids

Acids such as HCl, HNO<sub>3</sub> and HF will give up one proton (hydrogen ion) per molecule when they ionise. These are called **monoprotic** acids.

Some acids can give up more than one proton. These acids are called **polyprotic** acids. The term 'polyprotic' refers to the ability to donate more than one proton, not how readily these protons ionise in water. **Diprotic** acids can donate two protons.

### pH of monoprotic acids

A strong monoprotic acid will ionise completely, so the [H<sub>3</sub>O<sup>+</sup>] will be equal to the concentration of the acid. For example:



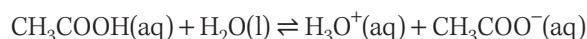
If [HNO<sub>3</sub>] = 0.1 mol L<sup>-1</sup>, then

$$[\text{HNO}_3] = [\text{H}_3\text{O}^+] = 0.1 \text{ mol L}^{-1} = 1 \times 10^{-1} \text{ mol L}^{-1} \text{ (complete ionisation of HNO}_3\text{)}$$

$$\text{pH} = 1$$

However, a weak monoprotic acid will only ionise to a small extent, producing very few [H<sub>3</sub>O<sup>+</sup>].

For example:



$$[\text{CH}_3\text{COOH}] = 0.1 \text{ mol L}^{-1} = 1 \times 10^{-1} \text{ mol L}^{-1}$$

$$[\text{H}_3\text{O}^+] \lll 1 \times 10^{-1} \text{ mol L}^{-1} \text{ (only partial ionisation of CH}_3\text{COOH)}$$

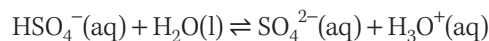
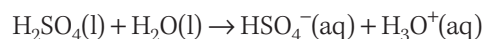
$$\text{pH} \gg 1$$

### pH of polyprotic acids

The measured pH of a 0.1 mol L<sup>-1</sup> solution of sulfuric acid (H<sub>2</sub>SO<sub>4</sub>) is around 0.69, not 1.0, which means it is a more acidic solution than a 0.1 mol L<sup>-1</sup> solution of monoprotic HCl. The smaller pH of the H<sub>2</sub>SO<sub>4</sub> indicates that there are more hydronium ions than HCl of equivalent concentration.

The pH value can be used to calculate the concentration of hydronium ions [H<sub>3</sub>O<sup>+</sup>] as almost 0.2 mol L<sup>-1</sup>. This means there are almost twice as many hydronium ions for H<sub>2</sub>SO<sub>4</sub> than for HCl when these acids are the same concentration.

The ionisation of sulfuric acid occurs in two steps:



H<sub>2</sub>SO<sub>4</sub> is a strong acid, and so a large number of the molecules ionise in the first equation. HSO<sub>4</sub><sup>-</sup> is a much weaker acid than H<sub>2</sub>SO<sub>4</sub>, so not many of the molecules will react with water and ionise. This means that the total concentration of hydronium ions is the number produced by the first ionisation plus the number produced by the second ionisation. Strong diprotic acids have a hydronium ion concentration greater than a monoprotic acid of the same concentration.

When a diprotic acid, such as H<sub>2</sub>SO<sub>4</sub>, reacts with a base, the number of protons that may be donated is two protons when the reaction goes to completion and all the acid has reacted. So when performing calculations involving a polyprotic acid the total number of protons must be taken into account.

Other acids, such as phosphoric acid (H<sub>3</sub>PO<sub>4</sub>), can donate up to three protons and are called **triprotic** acids and again, the second and third ionisation steps involve weak acids.

- When acids are added to water they undergo an ionisation reaction.
- When alkalis are added to water they undergo a dissociation reaction.
- The strength of an acid or base is determined by the proportion of molecules that have ionised or dissociated.
- Polyprotic acids can donate more than one proton per molecule. Diprotic acids donate two protons, and therefore, will produce more hydronium ions in solution than a monoprotic acid of the same concentration.

## CHECK YOUR UNDERSTANDING

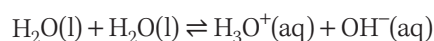
6.3

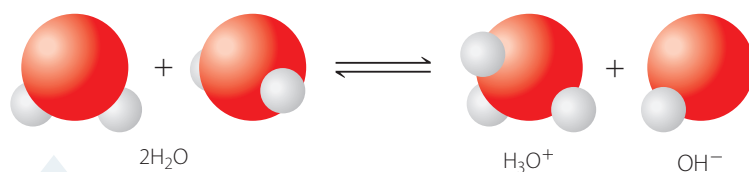
- 1 Identify the strong acids or strong bases in the following list.
  - Ammonia solution –  $\text{NH}_3(\text{aq})$
  - Carbonic acid –  $\text{H}_2\text{CO}_3(\text{aq})$
  - Nitric acid –  $\text{HNO}_3(\text{aq})$
  - Sulfuric acid –  $\text{H}_2\text{SO}_4(\text{aq})$
  - Sodium hydroxide –  $\text{NaOH}(\text{aq})$
- 2 Write the ionisation reaction(s) for the following acids in water. For polyprotic acids, include the stepwise ionisation reactions.
  - a Nitric acid ( $\text{HNO}_3$ )
  - b Sulfuric acid ( $\text{H}_2\text{SO}_4$ )
  - c Hydrofluoric acid ( $\text{HF}$ )
  - d Phosphoric acid ( $\text{H}_3\text{PO}_4$ )
- 3 Write the dissociation reaction for the following bases in water.
  - a Barium hydroxide ( $\text{Ba}(\text{OH})_2$ )
  - b Calcium oxide ( $\text{CaO}$ )
  - c Ammonium hydroxide ( $\text{NH}_4\text{OH}$ )
- 4
  - a Explain the difference between strength and concentration of an acid or base.
  - b Draw a diagram to show the difference between a concentrated solution of a strong acid and a dilute solution of a strong acid.
- 5
  - a What is the relationship between pH of a strong acid and pH of a weak acid of the same concentration?
  - b What is the relationship between pH of a strong base and pH of a weak base?
- 6
  - a Define 'diprotic'.
  - b Explain why the pH of a strong diprotic acid is smaller than that of a strong monoprotic acid of the same concentration.

## 6.4 Self-ionisation of water

The pH scale can also be used to measure the concentration of hydroxide ions in alkaline solutions. This is because, according to the Brønsted–Lowry theory, a base is a substance that accepts a proton from an acid. A substance cannot act as an acid (that is, donate a proton) without another substance that can act as a base (that is, accept a proton). The key to unlocking this relationship comes from understanding the reactions of water.

As you learnt in section 6.1, water's amphiprotic nature means that it can actually react with itself to form hydronium and hydroxide ions, as shown in Figure 6.11. This is an equilibrium reaction:





**FIGURE 6.11** Water reacts with itself in an equilibrium reaction to form hydronium and hydroxide ions, showing water's amphoteric nature.

While this is a reversible reaction, the forward reaction only occurs to a very small extent. Therefore, the equilibrium constant is small. The concentration of water is very large (approximately 55 M) and so effectively does not change significantly in the reaction, so  $[\text{H}_2\text{O}]$  is not included in the equilibrium expression. To represent this, the **self-ionisation constant ( $K_w$ )**, the ionic product constant for water, is used:

$$K_w = [\text{OH}^-][\text{H}_3\text{O}^+], \text{ where } K_w = 1.0 \times 10^{-14} (\text{mol L}^{-1})^2 \text{ at } 298 \text{ K.}$$

In pure water, the concentration of  $\text{OH}^-$  equals the concentration of  $\text{H}_3\text{O}^+$ :

$$[\text{OH}^-] = [\text{H}_3\text{O}^+]$$

This means at 298 K:

$$\begin{aligned} K_w &= [\text{OH}^-][\text{H}_3\text{O}^+] = 1.0 \times 10^{-14} \\ [\text{H}_3\text{O}^+]^2 &= 1.0 \times 10^{-14} \\ [\text{H}_3\text{O}^+] &= \sqrt{10^{-14}} = 10^{-7} \text{ M} \end{aligned}$$

At 298 K, when a solution is neutral,  $[\text{H}_3\text{O}^+] = [\text{OH}^-] = 10^{-7} \text{ M}$ . The pH at this temperature is 7. This is true only when the temperature is 298 K (25°C).

## Defining acidic, alkaline and neutral solutions

Earlier in this chapter, an acid was defined as a proton donor and a base as a proton acceptor. Now the pH of a solution can be used to determine whether it is acidic, alkaline or neutral.

- An **acidic solution** is one in which  $[\text{H}_3\text{O}^+] > [\text{OH}^-]$ . At 298 K, this is when  $[\text{H}_3\text{O}^+] > 10^{-7} \text{ mol L}^{-1}$ .
- An **alkaline solution** is one in which  $[\text{H}_3\text{O}^+] < [\text{OH}^-]$ . At 298 K, this is when  $[\text{H}_3\text{O}^+] < 10^{-7} \text{ mol L}^{-1}$ .
- A **neutral solution** is one in which  $[\text{H}_3\text{O}^+] = [\text{OH}^-]$ . At 298 K, this is when the concentration of both species =  $10^{-7} \text{ mol L}^{-1}$ .

## Calculating the pH of solutions using $K_w$

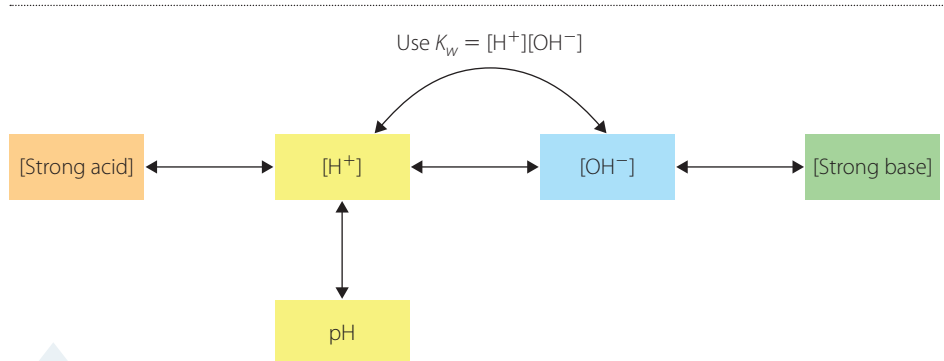
In section 6.2, pH was defined as  $-\log_{10}[\text{H}_3\text{O}^+]$  (or more simply  $-\log_{10}[\text{H}^+]$ ). This definition was then used to calculate the pH of a solution of known  $[\text{H}^+]$ . The relationship between  $[\text{OH}^-]$  and  $[\text{H}_3\text{O}^+]$  due to the self-ionisation of water now makes it possible to calculate the  $[\text{H}_3\text{O}^+]$  and thus the pH of alkaline solutions too.

If an alkaline solution has a known concentration of hydroxide ion  $[\text{OH}^-]$ , the relationship shown below can be used in calculating the  $[\text{H}_3\text{O}^+]$ :

$$K_w = [\text{OH}^-][\text{H}_3\text{O}^+] = 1.0 \times 10^{-14}$$

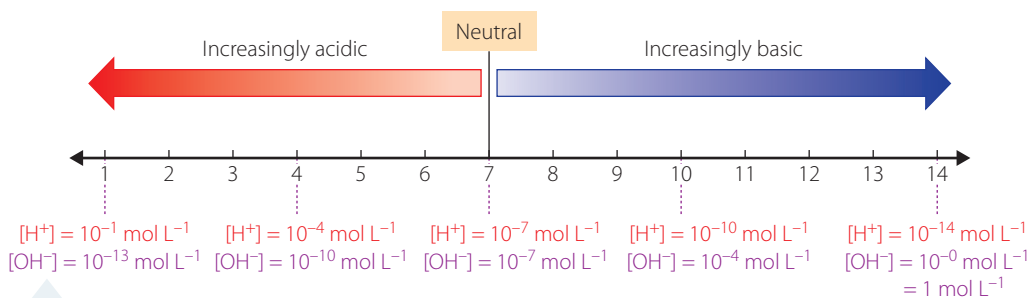
Once the hydronium ion concentration  $[\text{H}_3\text{O}^+]$  is known, the pH can be calculated. Figure 6.12 (page 160) shows a pathway that can be used to perform the pH calculations for strong acids and bases. The skill is in recognising what is given and what has to be determined.





**FIGURE 6.12** Pathway for performing pH calculations for strong acids and strong bases

Table 6.2 (page 147) showed the pH values for solutions and the corresponding  $\text{H}_3\text{O}^+$  and  $\text{OH}^-$  ion concentration. This is shown diagrammatically in Figure 6.13. Adding the superscripts of the two ion concentrations always gives  $-14$ , due to the  $K_w$  of water, which is equal to  $10^{-14}$  at  $25^\circ\text{C}$ .



**FIGURE 6.13** The pH scale

### WORKED EXAMPLE (6.2)

- Find the pH of a  $0.02 \text{ mol L}^{-1}$  solution of sodium hydroxide.
- If the  $[\text{OH}^-] = 3.98 \times 10^{-11} \text{ mol L}^{-1}$  of a solution of  $\text{HNO}_3$ , calculate the concentration of the solution.

ANSWER	LOGIC
$\text{NaOH}(\text{aq}) \rightarrow \text{Na}^+(\text{aq}) + \text{OH}^-(\text{aq})$ Therefore, $[\text{OH}^-] = \text{original} [\text{NaOH}] = 0.02 \text{ mol L}^{-1}$ . <b>1</b> $\text{pH} = 12.3$ $K_w = [\text{H}_3\text{O}^+][\text{OH}^-] = 1 \times 10^{-14}$ $= [\text{H}^+][0.02] = 1 \times 10^{-14}$	<ul style="list-style-type: none"> <li>Determine the species present.</li> <li><math>\text{NaOH}</math> is a strong base and dissociates 100% in solution.</li> <li>Determine <math>[\text{OH}^-]</math>.</li> <li>Choose the correct formula and insert the correct numbers.</li> <li>Hence, <math>[\text{H}^+] = \frac{1 \times 10^{-14}}{0.02} = 5 \times 10^{-13} \text{ mol L}^{-1}</math>  <math>\text{pH} = -\log[\text{H}^+] = -\log(5 \times 10^{-13}) = 12.3</math></li> </ul>

ANSWER	LOGIC
2 $[\text{HNO}_3] = 2.51 \times 10^{-4} \text{ mol L}^{-1}$	<ul style="list-style-type: none"> <li>▪ Use <math>K_w</math> to calculate the <math>[\text{H}_3\text{O}^+]</math>:  <math>K_w = [\text{H}_3\text{O}^+][\text{OH}^-] = 1 \times 10^{-14}</math>  <math>[\text{H}_3\text{O}^+] \times 3.98 \times 10^{-11} = 1 \times 10^{-14} \text{ mol L}^{-1}</math></li> <li>▪ Hence, <math>[\text{H}_3\text{O}^+] = \frac{1 \times 10^{-14}}{3.98 \times 10^{-11}} = 2.51 \times 10^{-4} \text{ mol L}^{-1}</math></li> <li>▪ Determine the species present:  <math>\text{HNO}_3</math> is a strong acid and dissociates 100% in solution.  <math>\text{HNO}_3(\text{aq}) + \text{H}_2\text{O}(\text{l}) \rightarrow \text{H}_3\text{O}^+(\text{aq}) + \text{NO}_3^-(\text{aq})</math></li> <li>▪ Determine the stoichiometric relationship and calculate the concentration:  <math>[\text{H}_3\text{O}^+] = [\text{HNO}_3]</math>  <math>[\text{HNO}_3] = 2.51 \times 10^{-4} \text{ mol L}^{-1}</math></li> </ul>

### TRY THESE YOURSELF

- 1 Potassium hydroxide is a strong base. Determine the pH of a  $0.04 \text{ mol L}^{-1}$  potassium hydroxide solution.
- 2 If the pH of the NaOH solution was 9.5, what was the concentration of the solution?
- 3 If  $[\text{OH}^-] = 4.7 \times 10^{-8} \text{ mol L}^{-1}$  in a HCl solution, calculate the concentration of HCl.

- In a solution, the concentration of  $[\text{H}_3\text{O}^+]$  compared to the  $[\text{OH}^-]$  can be used to determine whether a solution is acidic, alkaline or neutral.

### CHECK YOUR UNDERSTANDING

6.4

- 1 Write the equation to show the self-ionisation of water.
- 2
  - a Write the  $K_w$  expression for water. Include the numerical value of  $K_w$  at  $25^\circ\text{C}$ .
  - b Explain why  $[\text{H}_2\text{O}]$  is not included in the  $K_w$  expression.
- 3 Determine the concentrations of  $\text{H}_3\text{O}^+$  and  $\text{OH}^-$  in aqueous solutions of:
  - a black coffee (pH = 5.0)
  - b dishwasher liquid (pH = 13.0)
  - c cola drink (pH = 3.0).
- 4 Determine the pH of each of the following substances that ionise or dissociate completely into ions in aqueous solution.
  - a  $0.01 \text{ mol L}^{-1} \text{ HNO}_3$
  - b  $0.1 \text{ mol L}^{-1} \text{ NaOH}$
  - c  $1 \text{ mol L}^{-1} \text{ HCl}$
  - d  $0.230 \text{ mol L}^{-1}$  hydrochloric acid
  - e  $0.005 \text{ mol L}^{-1} \text{ Ca(OH)}_2$
- 5 What is the concentration of the following solutions?
  - a KOH solution with a pH of 11.5
  - b HCl with a pH of 3
  - c Calcium hydroxide ( $\text{Ca(OH)}_2$ ) solution with a pH of 10

## 6.5 Defining and calculating pOH

Just as pH is a measure of the  $[H^+]$ , the pOH for an aqueous solution is a measure of  $[OH^-]$ , and it is defined in the same way as pH.

The pOH of a solution is defined as the negative logarithm (to the base 10) of the hydroxide ion concentration:

$$pOH = -\log_{10}[OH^-]$$

$$[OH^-] = 10^{-pOH}$$

Calculating the pOH follows the same logic used for calculating pH.

### WORKED EXAMPLE 6.3

- 1 Calculate pOH, given  $[OH^-] = 1.5 \times 10^{-4} \text{ mol L}^{-1}$ .
- 2 Calculate  $[OH^-]$  when pOH = 5.8.
- 3 Calculate the concentration of a NaOH solution that had the same pOH as the solution in question 2.

ANSWER	LOGIC
$pOH = -\log_{10}[OH^-]$ $pOH = -\log_{10}(1.5 \times 10^{-4})$ <b>1</b> $pOH = 3.82$	<ul style="list-style-type: none"> <li>Choose the correct formula and insert numbers.</li> </ul>
$[OH^-] = 10^{-pOH}$ $[OH^-] = 10^{-5.8}$ <b>2</b> $[OH^-] = 1.6 \times 10^{-6} \text{ mol L}^{-1}$	<ul style="list-style-type: none"> <li>Choose the correct formula and insert numbers.</li> </ul>
<b>3</b> $[NaOH] = 1.6 \times 10^{-6} \text{ mol L}^{-1}$	<ul style="list-style-type: none"> <li>From question 2 you know <math>[OH^-] = 1.6 \times 10^{-6} \text{ mol L}^{-1}</math>.</li> <li>NaOH is a strong base that dissociates completely according to the equation:  <math>NaOH(aq) \rightarrow Na^+(aq) + OH^-(aq)</math></li> <li>Therefore, from the balanced equation:  <math>[NaOH] = [OH^-] = 1.6 \times 10^{-6} \text{ mol L}^{-1}</math></li> </ul>

#### TRY THESE YOURSELF

- 1 Determine the pOH of a solution, given  $[OH^-] = 0.001 \text{ mol L}^{-1}$ .
- 2 Determine the pOH of a solution, given  $[OH^-] = 7.2 \times 10^{-3} \text{ mol L}^{-1}$ .
- 3 Calculate  $[OH^-]$  when the pOH of the solution is 8.
- 4 Calculate  $[OH^-]$  when the pOH of the solution is 1.17.
- 5 Calculate the concentration of a KOH solution of pOH = 11.2.

### Relating pH and pOH

You know that  $K_w$  gives the following relationship between  $[OH^-]$  and  $[H_3O^+]$  in aqueous solutions:

$$K_w = [OH^-][H_3O^+], \text{ where } K_w = 1.0 \times 10^{-14} \text{ at } 298 \text{ K.}$$

Therefore, it follows that in aqueous solutions at 298 K (25°C):  $pH + pOH = 14$ .

This relationship can be used to convert between pH and pOH. It also provides another method for calculations that require pH of an alkaline solution or pOH of an acidic solution.

The following worked example provides an alternative method to answer the question in Worked example 6.3.

### WORKED EXAMPLE (6.4)

- Find the pH of a  $0.02 \text{ mol L}^{-1}$  solution of sodium hydroxide.
- If the pH of a  $\text{Ba}(\text{OH})_2$  solution is 8.3, what is the concentration of the solution?

ANSWER	LOGIC
<b>1</b> NaOH is a strong base and dissociates 100% in solution.	<ul style="list-style-type: none"> <li>Determine the species present.</li> </ul>
$\text{NaOH}(\text{aq}) \rightarrow \text{Na}^+(\text{aq}) + \text{OH}^-(\text{aq})$ Therefore, $[\text{OH}^-] = \text{original} [\text{NaOH}] = 0.02 \text{ mol L}^{-1}$ .	<ul style="list-style-type: none"> <li>Determine <math>[\text{OH}^-]</math>.</li> </ul>
$\text{pOH} = -\log_{10}[\text{OH}^-]$ $\text{pOH} = -\log_{10}(0.02) = 1.7$	<ul style="list-style-type: none"> <li>Choose the formula for calculating pOH and insert the numbers.</li> </ul>
$\text{pH} + \text{pOH} = 14$ $\text{pH} + 1.7 = 14$ $\text{pH} = 12.3$	<ul style="list-style-type: none"> <li>Choose the relationship between pH and pOH and insert the correct numbers.</li> </ul>
<b>2</b> $\text{pH} + \text{pOH} = 14$ $8.3 + \text{pOH} = 14$ $\text{pOH} = 5.7$	<ul style="list-style-type: none"> <li>Use the pH to determine the pOH.</li> </ul>
$[\text{OH}^-] = 10^{-\text{pOH}}$ $[\text{OH}^-] = 10^{-5.7} = 2.0 \times 10^{-6} \text{ mol L}^{-1}$	<ul style="list-style-type: none"> <li>Calculate <math>[\text{OH}^-]</math> using the appropriate formula.</li> </ul>
$\text{Ba}(\text{OH})_2(\text{aq}) \rightarrow \text{Ba}^{2+}(\text{aq}) + 2\text{OH}^-(\text{aq})$	<ul style="list-style-type: none"> <li>Write a balanced equation for the dissociation of the strong base <math>\text{Ba}(\text{OH})_2</math>.</li> </ul>
$[\text{Ba}(\text{OH})_2] = \frac{1}{2} [\text{OH}^-]$ $= \frac{1}{2} \times 2.0 \times 10^{-6}$ $= 1.0 \times 10^{-6} \text{ mol L}^{-1}$	<ul style="list-style-type: none"> <li>Use the stoichiometric relationship from the balanced equation to calculate the concentration of the solution.</li> </ul>

#### TRY THESE YOURSELF

- Potassium hydroxide is a strong base. Determine the pH of a  $0.004 \text{ mol L}^{-1}$  potassium hydroxide solution.
- Hydrochloric acid is a strong acid. Determine the pOH of a  $0.023 \text{ mol L}^{-1}$  HCl solution.
- If the pH of a  $\text{Ba}(\text{OH})_2$  solution is 10.5, what is the concentration of the solution?

## Diluting, pH and pOH

In Investigation 6.2 you compared the pH of different concentrations of the same solutions of acid and base to determine how concentration affects pH.

Because pH is a measure of  $[\text{H}_3\text{O}^+]$ , changing the concentration by adding or removing the solvent (such as water in the case of aqueous solutions) will change the pH.

Table 6.1 (page 147) shows how a change by a factor of 10 in concentration results in a pH change of one unit.

The following worked examples show the effect on pH and pOH of changing concentration.

### WORKED EXAMPLE 6.5

- 1 If a solution of HF with a pH of 3 was diluted by a factor of 100, what is the pH of the final solution?
- 2 A solution of 500 mL of NaOH of pOH 5 was left to evaporate until the final volume was 40 mL. Calculate the following.
  - a pOH
  - b pH of the final solution

ANSWERS	LOGIC
<b>1</b> The final pH is 5.	<ul style="list-style-type: none"><li>▪ Recall the relationship between pH and concentration. A change by a factor of 10 in concentration is equivalent to a change in 1 unit in the pH scale.</li><li>▪ Therefore, a change in concentration by a factor of 100 means a change in pH by two units.</li><li>▪ The solution is being diluted, so therefore, the concentration of <math>\text{H}_3\text{O}^+</math> will decrease, so the pH will increase and the pH of the final solution will be 5.</li></ul>
<b>2 a</b> $c_1 = 10^{-5} \text{ mol L}^{-1}$ , $V_1 = 500 \text{ mL}$ , $c_2 = ?$ , $V_2 = 40 \text{ mL}$ $10^{-5} \times 500 = c_2 \times 40$ $c_2 = \frac{(10^{-5} \times 500)}{40} = 1.25 \times 10^{-4} \text{ mol L}^{-1}$ $\text{pOH} = -\log [\text{OH}^-] = -\log(1.25 \times 10^{-4}) = 3.90$ <b>b</b> $\text{pH} + 3.9 = 14$ $\text{pH} = 10.1$	<ul style="list-style-type: none"><li>▪ Calculate the concentration of <math>[\text{OH}^-]</math> ions: <math>[\text{OH}^-] = 10^{-\text{pOH}}</math></li><li>▪ <math>[\text{OH}^-] = 10^{-5} \text{ mol L}^{-1}</math></li><li>▪ Use the formula <math>c_1V_1 = c_2V_2</math> to calculate the new <math>[\text{OH}^-]</math>.</li><li>▪ Calculate pOH.</li><li>▪ Use the relationship <math>\text{pH} + \text{pOH} = 14</math> to calculate pH.</li></ul>

#### TRY THESE YOURSELF

- 1 If a solution of HCl with a pH of 1 is diluted by a factor of 1000, what will the pH of the diluted solution be?
- 2 If a solution of  $\text{Na}_2\text{O}$  with a pOH of 11.5 is diluted by a factor of 100, what will the pOH of the diluted solution be?
- 3 A 250 mL solution of  $\text{H}_2\text{SO}_4$  of pOH 10.4 was left to evaporate until the resulting volume was 20 mL. What is the pH of the resultant solution?

- The pOH of a solution is defined as the negative logarithm (to the base 10) of the hydroxide ion concentration:

$$\text{pOH} = -\log_{10}[\text{OH}^-]$$

$$[\text{OH}^-] = 10^{-\text{pOH}}$$

- $\text{pH} + \text{pOH} = 14$

### CHECK YOUR UNDERSTANDING

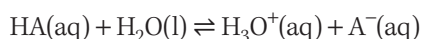
6.5

- Define 'pOH'.
  - What is the relationship between pH and pOH?
- Determine the pOH of a solution, given  $[\text{OH}^-] = 9.4 \times 10^{-2} \text{ mol L}^{-1}$ .
  - Calculate  $[\text{OH}^-]$  when the pOH of the solution is 3.21.
- Determine the concentrations of  $\text{H}_3\text{O}^+$  and  $\text{OH}^-$  in aqueous solutions of:
  - oven cleaner (pOH = 0.0)
  - lemon juice (pOH = 11)
  - toothpaste (pH = 8).
- Determine the pH of each of the following substances that ionise or dissociate completely into ions in aqueous solution.
  - $1.27 \text{ mol L}^{-1}$  hydrochloric acid
  - $0.052 \text{ mol L}^{-1}$  NaOH
- Determine the pOH of each of the following substances that ionise or dissociate completely into ions in aqueous solution.
  - $0.0175 \text{ mol L}^{-1}$  nitric acid
  - $0.033 \text{ mol L}^{-1}$   $\text{Ba}(\text{OH})_2$
- Calculate the molarity of the following solutions.
  - 20 mL of HCl with a pOH of 11
  - 300 mL of a calcium hydroxide solution with a pH of 10
- Explain the relationship between pH of a concentrated solution and pH of a dilute solution of the same substance.
- An alkaline solution has a pH of 8. If 10 mL of this solution is diluted so the final volume is 1000 mL, what is the pH of the diluted solution?
  - If a 100 mL container of orange juice concentrate had a pH of 5 and the instructions on the container were to add the concentrate to 900 mL of water, what would be the pH of the diluted solution?
  - What is the pOH of a solution that was made by adding 400 mL of water to 250 mL of a  $5.0 \times 10^{-4} \text{ mol L}^{-1}$  KOH solution?

## 6.6 Applying dissociation constants for acids

As explained earlier in this chapter, in a weak acid, only some of the acid molecules ionise. This means that there is an equilibrium for this ionisation reaction.

The general equation for the ionisation reaction of a weak acid is:



As you learnt in section 3.5, the equilibrium constant for the ionisation of a weak acid is called the acid dissociation constant and is represented by  $K_a$ .

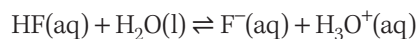


You may wish to revise what you have already covered on equilibrium expressions and dissociation constants for acids and bases. Refer to chapter 3, page 73.

Therefore, the general expression for the dissociation constant is:

$$K_a = \frac{[\text{H}_3\text{O}^+][\text{A}^-]}{[\text{HA}]}$$

For example, the weak acid HF ionises according to the reaction below:



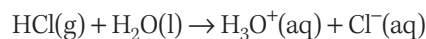
And the equilibrium expression for this reaction is:

$$K_a = \frac{[\text{H}_3\text{O}^+][\text{F}^-]}{[\text{HF}]}$$

When the weak acid hydrofluoric acid ionises in water, only a small percentage of the molecules ionise. The  $K_a$  of hydrofluoric acid is very small because the extent of the forward reaction is very small.

$$K_a = \frac{[\text{H}_3\text{O}^+][\text{F}^-]}{[\text{HF}]} = 7.6 \times 10^{-4}$$

When a strong acid such as hydrochloric acid ionises in water, almost 100 per cent reacts to form the hydronium and chloride ions:



The  $K_a$  of a strong acid is very large because there is a large concentration of the products and very little of the reactants. The conjugate base  $\text{Cl}^-$  is very weak and does not readily react in the reverse reaction, so the reverse reaction only occurs to a very small extent. It is not necessary to use the equilibrium arrows for the reactions of strong acids since they effectively go to completion.

As you learnt in chapter 3, the size of the dissociation constant provides information about the degree of ionisation that occurs. The larger the  $K_a$  the larger the value of the numerator in the equilibrium expression; hence, the greater the concentration of ions (products) compared to the concentration of un-dissociated molecules of the acid (reactants) and therefore, the greater the degree of dissociation.

The pH can be used to determine the concentration of hydronium ions. As you have already learnt, for strong acids, the concentration of acid molecules at equilibrium is negligible, so the pH will give a direct measurement of the concentration of the acid. However, for weak acids, the pH does not give a direct measurement of the acid concentration. Instead, the  $K_a$  and the concentration of hydronium ions needs to be used to calculate the concentration of the acid.

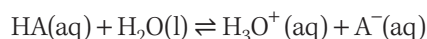
Acid dissociation constants only apply when the acid is dissolved in water and are temperature dependent. They are usually quoted at 25°C.

**TABLE 6.5** Acidity constants ( $K_a$ ) of some weak acids

ACID NAME	FORMULA	$K_a$
Ammonium ion	$\text{NH}_4^+$	$5.6 \times 10^{-10}$
Ethanoic	$\text{CH}_3\text{COOH}$	$1.7 \times 10^{-5}$
Hydrocyanic	$\text{HCN}$	$6.3 \times 10^{-10}$
Hydrofluoric	$\text{HF}$	$7.6 \times 10^{-4}$
Lactic	$\text{HC}_3\text{H}_5\text{O}_3$	$1.4 \times 10^{-4}$
Methanoic	$\text{HCOOH}$	$1.8 \times 10^{-4}$
Nitrous	$\text{HNO}_2$	$7.2 \times 10^{-4}$

## Determining the $K_a$

The  $K_a$  of an acid can be determined by measuring the pH of the sample and using this to calculate the hydronium ion concentration. Using HA to represent any acid and  $A^-$  to represent the conjugate base, the reaction of a weak acid with water can be represented as:



And the equilibrium expression is:

$$K_a = \frac{[H_3O^+][A^-]}{[HA]}$$

Since  $[A^-]$  must equal  $[H_3O^+]$ , then:

$$K_a = \frac{[H_3O^+]^2}{[HA]}$$

The following assumptions are made:

- 1 At equilibrium,  $[HA]$  is the same as the initial concentration; the weak acid only ionises to a small degree in water.
- 2  $[H_3O^+]$  produced by the self-ionisation of water is negligible and has no effect on the calculations.

### WORKED EXAMPLE (6.6)

- 1 A 0.10 M hypobromous (HOBr) acid has a pH of 4.80. Determine  $K_a$  for this acid.
- 2 Determine the pH of a 0.01 M solution of HF ( $K_a = 6.8 \times 10^{-4}$ ).

ANSWER	LOGIC
1 $HOBr(aq) + H_2O(l) \rightleftharpoons H_3O^+(aq) + OBr^-(aq)$	<ul style="list-style-type: none"> <li>Write the equation for the ionisation of the acid.</li> </ul>
$K_a = \frac{[H_3O^+][OBr^-]}{[HOBr]}$	<ul style="list-style-type: none"> <li>Write the expression for <math>K_a</math>.</li> </ul>
$[H_3O^+] = 10^{-pH}$ $[H_3O^+] = 10^{-4.80}$ Therefore, $[H_3O^+] = 1.58 \times 10^{-5} M$	<ul style="list-style-type: none"> <li>Choose the correct formula to calculate the hydronium ion concentration and insert the numbers.</li> </ul>
$K_a = \frac{[H_3O^+][OBr^-]}{[HOBr]} \quad ([OBr^-] = [H_3O^+])$ $= \frac{[H_3O^+]^2}{0.10}$ $= \frac{(1.58 \times 10^{-5})^2}{0.10} = 2.5 \times 10^{-9}$	<ul style="list-style-type: none"> <li>Insert numbers into the formula to calculate the <math>K_a</math> and calculate the answer. Assume <math>[HOBr]_{initial} = [HOBr]_{equil} = 0.10</math>.</li> </ul>

**ANSWER**

2 pH = 2.58

**LOGIC**

- Choose correct formula and insert numbers:

$$K_a = \frac{[\text{H}_3\text{O}^+][\text{F}^-]}{[\text{HF}]} = 6.8 \times 10^{-4}$$

$$= \frac{[\text{H}_3\text{O}^+]^2}{[\text{HF}]} \text{ as } [\text{F}^-] = [\text{H}_3\text{O}^+]$$

$$[\text{H}_3\text{O}^+]^2 = 6.8 \times 10^{-4} \times [\text{HF}]$$

$$[\text{H}_3\text{O}^+] = \sqrt{(6.8 \times 10^{-4} \times 0.01)} = 2.6 \times 10^{-3}$$

- Determine pH:

$$\text{pH} = -\log[\text{H}_3\text{O}^+]$$

$$= -\log(2.6 \times 10^{-3}) = 2.58$$

**TRY THESE YOURSELF**

- The pH of a  $0.050 \text{ mol L}^{-1}$  solution of nitrous acid ( $\text{HNO}_2$ ) is measured as 2.22. Determine the acid dissociation equilibrium constant.
- Determine the pH of a  $0.2 \text{ mol L}^{-1}$  ethanoic acid solution ( $K_a = 1.7 \times 10^{-5}$ ).

**INVESTIGATION 6.4****Determining the  $K_a$  for a weak acid****INTRODUCTION**

This investigation will involve using the weak acid – acetic acid. You will be given the initial concentration of the acetic acid and you will be able to determine the equilibrium concentration of the hydronium ion using the pH meter.

Hence, using the same methodology as was used in Worked example 6.6 (page 167), you will be able to determine the equilibrium concentrations of the acetate ion and the acetic acid. Finally, you can use the equilibrium concentrations for all species to calculate the  $K_a$  for acetic acid.

**AIM**

To determine the  $K_a$  for acetic acid.

**MATERIALS**

- 100 mL  $0.100 \text{ mol L}^{-1}$  acetic acid ( $\text{CH}_3\text{COOH}$ ),
- Distilled water
- Wash bottle containing distilled water
- 4 × 100 mL volumetric flasks (you could use one 100 mL volumetric flask to make up each solution, then pour the solution into a beaker or conical flask, then rinse the volumetric flask with water and use it to make the next solution)
- 5 × 150 mL beakers
- 10 mL bulb pipette
- 25 mL bulb pipette



- » ■ Pipette filler
- Disposable plastic dropper
- pH meter
- 5 small labels
- Safety glasses

WHAT ARE THE RISKS IN DOING THIS INVESTIGATION?	HOW CAN YOU MANAGE THESE RISKS TO STAY SAFE?
Chemicals may splash onto your skin or into your eyes.	Wear safety glasses and wash your hands at the end of the experiment.
Glassware may break.	Keep glassware away from the edge of the bench. Place pipettes in the fold of a book to prevent them rolling around.



What other risks are associated with your investigation? How can you manage these?

#### METHOD

- 1 Label five beakers A–E.
- 2 Pour 100 mL of  $0.100 \text{ mol L}^{-1}$  acetic acid into the beaker labelled A.
- 3 Measure the pH of solution A using a pH meter and record the value in a table.
- 4 Use the 25 mL bulb pipette to transfer 25 mL of solution from beaker A to a clean 100 mL volumetric flask.
- 5 Fill the volumetric flask to the line with distilled water. Remember to use a dropper to add the last few mL of water.
- 6 Pour the solution into the beaker labelled B.
- 7 Measure the pH of solution B using a pH meter and record the value in a table.
- 8 Repeat steps 4–7, using appropriate pipettes to make solutions (C–E) as shown in the table below.

#### NOTE

- Always rinse the pipette with a small amount of the solution that you are putting in it.
- If you are re-using the volumetric flask, rinse it with distilled water before re-using it.
- Always rinse the pH meter with distilled water after use.
- Measure the pH of a solution before using it to make other solutions.

SOLUTION	VOLUME/CHEMICAL
A	100 mL $0.100 \text{ mol L}^{-1}$ acetic acid
B	25 mL solution A + 75 mL distilled water
C	10 mL solution A + 90 mL distilled water
D	25 mL solution C + 75 mL distilled water
E	10 mL solution C + 90 mL distilled water

#### RESULTS

Record results in an appropriately formatted table.

#### ANALYSIS OF RESULTS

- 1 Calculate the initial concentration of  $\text{CH}_3\text{COOH}$  for each solution (A–E).
- 2 Draw a graph of pH versus  $[\text{CH}_3\text{COOH}]$ .
- 3 Use a spreadsheet program to draw a line of best fit for this graph and note the equation for the line of best fit.
- 4 Use the equation for the line of best fit for an initial concentration value of  $\text{CH}_3\text{COOH}$  within the range for the investigation to determine the pH.
- 5 Use the data in step 4 to determine the equilibrium concentrations of the hydronium ion, acetate ion and acetic acid.

- » 6 Write a balanced chemical equation for the ionisation of acetic acid.  
7 Write the  $K_a$  expression and calculate the  $K_a$  for the dissociation of acetic acid.

#### DISCUSSION

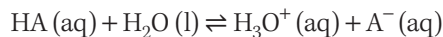
- 1 Why was the  $K_a$  calculated using the line of best fit for the graphed data?
- 2 Outline another method that could have been used to analyse the experimental data to calculate the  $K_a$ .
- 3 According to chemical data tables, the  $K_a$  for acetic acid at 25°C is  $1.8 \times 10^{-5}$ . Compare the methods for data analysis in terms of validity and accuracy of the  $K_a$ .

#### EXTENSION

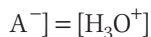
The effect of temperature on the value of the  $K_a$  for the dissociation of acetic acid could be determined by heating the solutions (A–E) to a temperature of 50°C. The pH of each of the solutions could be measured. The same method of analysis could be used to determine the  $K_a$  for acetic acid at 50°C. You could then compare this value with the value from the original experiment and discuss the effect of temperature on the equilibrium position for this reaction.

### Percentage ionisation

**Percentage ionisation** is the percentage of acid that has ionised in water. The general reaction for weak acids with water is:



For each proton that is donated to water, one  $\text{A}^-$  ion is formed (provided the acid is monoprotic). By measuring the pH, the  $[\text{H}_3\text{O}^+]$  can be determined and this is equal to  $[\text{A}^-]$ :



This can then be used to calculate the percentage of the original acid that has been ionised. Note that  $[\text{HA}]$  here refers to the initial concentration and not the concentration at equilibrium:

$$\text{Percentage ionisation} = \frac{[\text{A}^-]}{[\text{HA}]} \times 100\%$$

Once the percentage ionisation is known, a more accurate calculation for  $K_a$  can be determined. Some weak acids may have significant ionisation (less than 100%), so the assumption that  $[\text{HA}]_{\text{initial}} = [\text{HA}]_{\text{equil}}$  for  $K_a$  calculations may not be valid.

#### WORKED EXAMPLE (6.7)

Hydrofluoric acid (HF) reacts with water, as shown by:



Determine the percentage ionisation of HF(aq) in a 0.1 M HF solution that was found to have a pH of 2.1.

ANSWER	LOGIC
$[\text{H}_3\text{O}^+] = 10^{-\text{pH}} = 10^{-2.1}$ $= 0.008 \text{ mol L}^{-1}$ Percentage ionisation = 8%	<ul style="list-style-type: none"> <li>Choose correct formula and insert numbers.</li> </ul>
$\text{HF(g)} + \text{H}_2\text{O(l)} \rightleftharpoons \text{H}_3\text{O}^+ \text{ (aq)} + \text{F}^- \text{ (aq)}$ $[\text{F}^-] = [\text{H}_3\text{O}^+] = 0.008 \text{ mol L}^{-1}$	<ul style="list-style-type: none"> <li>Determine <math>[\text{F}^-]</math>.</li> </ul>

ANSWER	LOGIC
	<ul style="list-style-type: none"> <li>▪ Percentage ionisation of HF:               <math display="block">= \frac{[\text{F}^-]}{[\text{HF}]} \times \frac{100}{1}</math> <math display="block">= \frac{0.008}{0.1} \times \frac{100}{1}</math> <math display="block">= 8\%</math> </li> </ul>

#### TRY THESE YOURSELF

- 1 A  $0.1 \text{ mol L}^{-1}$  solution of methanoic acid ( $\text{HCOOH}$ ) has a pH of 2.87 ( $K_a = 1.8 \times 10^{-5}$ ). What is the percentage ionisation?
- 2 The pH of a  $0.137 \text{ mol L}^{-1}$  solution of nitrous acid ( $\text{HNO}_2$ ) is 2.08 ( $K_a = 7.2 \times 10^{-4}$ ). What is the percentage ionisation?

## $K_a$ of polyprotic acids

As discussed earlier in section 6.3, a separate equation can be written for each step of the ionisation of a polyprotic acid. Therefore, each step has its own equilibrium expression and  $K_a$  value. These are generally labelled  $K_{a1}$ ,  $K_{a2}$  and so on, and the first  $K_a$  is usually the largest.

### Strong polyprotic acids

For strong polyprotic acids, the  $K_{a1}$  is much larger than the  $K_a$  of any subsequent ionisation steps. Consider sulfuric acid, which is a strong diprotic acid. It can release two protons, which is done in two steps. The first proton is donated very easily to water and the conjugate base,  $\text{HSO}_4^-$  is produced, as shown in the equation below:



The donation of the second proton from  $\text{HSO}_4^-$  is shown in the second reaction equation:



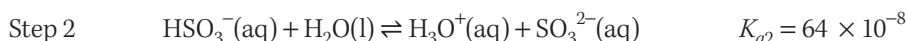
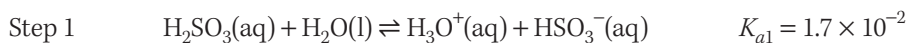
The conjugate base  $\text{HSO}_4^-$  from step 1 is now donating a proton and acting as a weak acid by reacting with water to form  $\text{SO}_4^{2-}$ . The weaker a weak acid, the stronger its conjugate base, so the reverse reaction in step 2 occurs to a higher degree.

In summary:  $\text{H}_2\text{SO}_4$  produced will ionise since it is a strong acid, as can be seen by the large  $K_{a1}$  (which is  $10^9$ ) so will not be present in any significant quantity in the final solution. Only a very small percentage of  $\text{SO}_4^{2-}$  will form since  $\text{HSO}_4^-$  is a very weak acid (step 2) as can be seen by its small  $K_{a2}$  of  $10^{-2}$ .  $\text{HSO}_4^-$  is amphiprotic (that is, it will both accept and donate a proton) so it is present as a product in step 1 and as a reactant in step 2. Therefore, at equilibrium the main species present will be water,  $\text{H}_3\text{O}^+$  and  $\text{HSO}_4^-$ .

### Weak polyprotic acids

Weak polyprotic acids will also donate electrons through a series of steps; however, the smaller  $K_a$  values of these steps results in a different group of species in the final solution.

Consider the weak diprotic acid, sulfurous acid ( $\text{H}_2\text{SO}_3$ ), which dissociates in two steps according to the following reaction equations:





Since sulfurous acid is a weak acid in step 1, it is in equilibrium with the conjugate base,  $\text{HSO}_3^-$ . In step 2,  $\text{HSO}_3^-$  acts as a weak acid and donates a proton to water to produce the conjugate base,  $\text{SO}_3^{2-}$ . While  $K_{a1}$  is bigger than  $K_{a2}$ , they still represent weak acids so all three species ( $\text{H}_2\text{SO}_3$ ,  $\text{HSO}_3^-$  and  $\text{SO}_3^{2-}$ ) would be expected to be present in an aqueous solution of sulfurous acid.

## Understanding $\text{p}K_a$

As has just been discussed, the acid dissociation constant ( $K_a$ ) provides an easy way of determining the strength of an acid: the greater the value of  $K_a$ , the stronger the acid.

The values of  $K_a$  are spread over a wide range so the term  $\text{p}K_a$  (like pH) was introduced as a convenient way of comparing acid strength.  $\text{p}K_a$  is defined as:

$$\text{p}K_a = -\log_{10} K_a$$

Just as a smaller pH means greater  $[\text{H}^+]$  and a stronger acid provided concentrations are the same, smaller  $\text{p}K_a$  corresponds to greater acid strength. For example, the  $\text{p}K_a$  of acetic acid is 4.8, while the  $\text{p}K_a$  for lactic acid is 3.8. This makes lactic acid a stronger acid than acetic acid.

Table 6.6 shows the  $K_a$  and  $\text{p}K_a$  of some weak acids.

**TABLE 6.6** Acidity constants,  $K_a$ , and  $\text{p}K_a$  of some weak acids

ACID NAME	FORMULA	$K_a$	$\text{p}K_a$
Hydrofluoric	HF	$7.6 \times 10^{-4}$	3.12
Lactic	$\text{HC}_3\text{H}_5\text{O}_3$	$1.4 \times 10^{-4}$	3.85
Ethanoic	$\text{CH}_3\text{COOH}$	$1.7 \times 10^{-5}$	4.77
Hydrocyanic	HCN	$6.3 \times 10^{-10}$	9.20
Ammonium ion	$\text{NH}_4^+$	$5.6 \times 10^{-10}$	9.25



Interpreting graphs:  
How do indicators work?

Another important point is the relationship between pH and  $\text{p}K_a$  as shown in the equation below:

$$\text{pH} = \text{p}K_a + \log_{10} \frac{[\text{A}^-]}{[\text{HA}]}$$

This relationship is important when dealing with buffers and will be explored further in the next chapter.

- The acid dissociation constant ( $K_a$ ) is a measure of the strength of acids. Strong acids ionise completely in water;  $K_a$  is very large. Weak acids only ionise to a small degree in water;  $K_a$  is small.
- The smaller the value for  $\text{p}K_a$ , the stronger the acid.
- The larger the value of  $\text{p}K_a$ , the weaker the acid.

## CHECK YOUR UNDERSTANDING

6.6

- Write the acid dissociation equilibrium expression for the following acids in water.
  - Hypobromous (HOBr)
  - Hydrocyanic (HCN)
  - Ammonium ion ( $\text{NH}_4^+$ )
- Why is water not included in the expression for the acid dissociation constant?

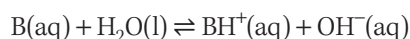


- 3 a** Write the definition of  $pK_a$ .
- b** Describe the relationship between the strength of an acid and the value of  $K_a$ .
- c** Describe the relationship between strength of an acid and the value of  $pK_a$ .
- d** Explain the relationship between pH,  $K_a$  and  $pK_a$ .
- 4** Malic acid ( $C_4H_6O_5$ ) is a diprotic acid, commonly found in fruit. Write the two acid dissociation equilibrium expressions for the ionisation of this acid in water. Predict which  $K_a$  will be larger and explain why.
- 5** Four unknown solutions W, X, Y and Z were found to have the following  $K_a$  or  $pK_a$  values respectively:  $1.7 \times 10^{-5}$ , 3.8, 7.4 and  $6.3 \times 10^{-5}$ . Arrange these in order of decreasing acid strength (strongest to weakest).
- 6** List any assumptions that are made when performing pH, concentration and  $K_a$  calculations involving weak acids.
- 7** Phenol ( $C_6H_5OH$ ) was used as an antiseptic for wounds and in calamine lotions for skin irritations. It is a weak monoprotic acid with a  $K_a$  of  $1.05 \times 10^{-10}$ .
- a** Calculate the pH of a  $3.5 \times 10^{-3} \text{ mol L}^{-1}$  solution of phenol.
- b** Determine the percentage ionisation.
- 8 a** Write an equation showing the equilibrium that occurs when ethanoic (acetic) acid ionises in water.
- b** The  $K_a$  for ethanoic acid is  $1.74 \times 10^{-5} \text{ mol L}^{-1}$ . What is the pH of a  $0.4 \text{ mol L}^{-1}$  solution?
- 9 a** Use the pH and concentration of the weak acid solutions given below to calculate  $K_a$  and  $pK_a$ .
- i**  $0.10 \text{ mol L}^{-1}$  HCN (pH = 5.15)
- ii**  $0.017 \text{ mol L}^{-1}$  HS (pH = 4.41)
- b** Which of these acids is the strongest?
- 10** Propanoic acid ( $C_2H_5COOH$ ) is a weak monoprotic acid that is used in food preservation. What is the  $[H_3O^+]$  of a  $0.10 \text{ mol L}^{-1}$  solution of propanoic acid given  $pK_a = 4.87$ ?

## 6.7 Dissociation constants for bases

As explained earlier in section 6.3, in a weak base only some of the base molecules dissociate. So, similar to weak acids, there is an equilibrium for this dissociation reaction.

The general equation for a base reacting with water is:

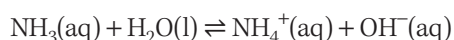


As you learnt in chapter 3 (page 74), the equilibrium constant for the dissociation of a weak base is called the base dissociation constant and represented by  $K_b$ .

Therefore, the general expression for the dissociation constant for a weak base is:

$$K_b = \frac{[BH^+][OH^-]}{[B]}$$

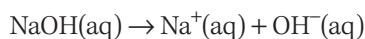
For example:



$$K_b = \frac{[NH_4^+][OH^-]}{[NH_3]} = 1.8 \times 10^{-5}$$

As with acids, the size of  $K_b$  is a measure of the strength of the base. The larger the  $K_b$ , the larger the value of the numerator in the equilibrium expression. Hence, the greater the concentration of ions (products) compared to the concentration of the un-dissociated base (reactants), and therefore, the greater the degree of dissociation.

When a strong base, such as sodium hydroxide, dissociates in water, almost 100 per cent reacts to form sodium and hydroxide ions, as per:



The  $K_b$  of a strong base is very large because of this high percentage of dissociation.

The pOH or pH can be used to determine the concentration of hydroxide ions. As you have already learnt for strong bases, the dissociation is effectively 100%. This means the final concentration of the original base is negligible, so the pOH will give a direct measurement of the concentration of the original base species. However, for weak bases, the pOH does not give a direct measurement of the base concentration. Instead, the  $K_b$  and the concentration of hydroxide ions need to be used to calculate the concentration of the base.

**TABLE 6.7** Dissociation constants for some weak bases at 25°C.

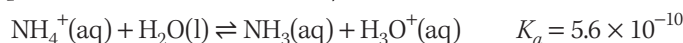
BASE NAME AND FORMULA	DISSOCIATION EQUATION	$K_b$
Phosphate ion ( $\text{PO}_4^{3-}$ )	$\text{PO}_4^{3-}(\text{aq}) + \text{H}_2\text{O}(\text{l}) \rightleftharpoons \text{HPO}_4^{2-}(\text{aq}) + \text{OH}^-(\text{aq})$	$5.9 \times 10^{-3}$
Methylamine ( $\text{CH}_3\text{NH}_2$ )	$\text{CH}_3\text{NH}_2 + \text{H}_2\text{O}(\text{l}) \rightleftharpoons \text{CH}_3\text{NH}_3^+(\text{aq}) + \text{OH}^-(\text{aq})$	$4.2 \times 10^{-4}$
Carbonate ion ( $\text{CO}_3^{2-}$ )	$\text{CO}_3^{2-}(\text{aq}) + \text{H}_2\text{O}(\text{l}) \rightleftharpoons \text{HCO}_3^-(\text{aq}) + \text{OH}^-(\text{aq})$	$2.1 \times 10^{-4}$
Ammonia ( $\text{NH}_3$ )	$\text{NH}_3(\text{aq}) + \text{H}_2\text{O}(\text{l}) \rightleftharpoons \text{NH}_4^+(\text{aq}) + \text{OH}^-(\text{aq})$	$1.8 \times 10^{-5}$
Hydrazine ( $\text{NH}_2\text{NH}_2$ )	$\text{NH}_2\text{NH}_2 + \text{H}_2\text{O}(\text{l}) \rightleftharpoons \text{NH}_2\text{NH}_3^+(\text{aq}) + \text{OH}^-(\text{aq})$	$8.5 \times 10^{-7}$
Aniline ( $\text{C}_6\text{H}_5\text{NH}_2$ )	$\text{C}_6\text{H}_5\text{NH}_2 + \text{H}_2\text{O}(\text{l}) \rightleftharpoons \text{C}_6\text{H}_5\text{NH}_3^+(\text{aq}) + \text{OH}^-(\text{aq})$	$7.4 \times 10^{-10}$

Just as there is a relationship between pH and pOH ( $\text{pH} + \text{pOH} = 14$ ) there is also a relationship between  $K_a$  and  $K_b$  for conjugate acid–base pairs:

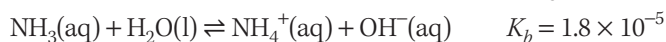
$$K_a \times K_b = K_w$$

For example, consider the conjugate acid–base pair  $\text{NH}_4^+$  and  $\text{NH}_3$ .

The ionisation equation for the weak acid ( $\text{NH}_4^+$ ) is:



The dissociation equation for the corresponding conjugate base  $\text{NH}_3$  is:



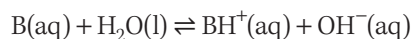
$$K_a \times K_b = 5.6 \times 10^{-10} \times 1.8 \times 10^{-5}$$

$$= 1.0 \times 10^{-14}$$

$$= K_w$$

## Determining the $K_b$

The  $K_b$  of a base can be determined by measuring the pH or pOH of the sample and using this to calculate the hydroxide ion concentration. Using B to represent any base and  $\text{BH}^+$  to represent the conjugate acid, the reaction of a weak base with water can be represented as:



And the equilibrium expression is:  $K_b = \frac{[\text{BH}^+][\text{OH}^-]}{[\text{B}]}$

Since  $[\text{OH}^-]$  must equal  $[\text{BH}^+]$ , then:

$$K_b = \frac{[\text{OH}^-]^2}{[\text{B}]}$$

As for weak acids, the following assumptions are made.

- 1 At equilibrium,  $[\text{B}]$  is the same as the initial concentration; the weak base only ionises to a small degree in water.
- 2  $[\text{OH}^-]$  produced by the self-ionisation of water is negligible and has no effect on the calculations.

The method used to calculate concentrations,  $K_b$  and pOH is the same as that used for acid calculations.



Interpreting data and diagrams

### WORKED EXAMPLE (6.8)

- 1 A  $5.0 \times 10^{-3} \text{ mol L}^{-1}$  solution of the weak base codeine ( $\text{C}_{18}\text{H}_{21}\text{NO}_3$ ) has a pOH of 4.05. Determine  $K_b$  for this base.
- 2 Determine the pH of a  $0.01 \text{ mol L}^{-1}$  solution of  $\text{NH}_3$  ( $K_b = 1.8 \times 10^{-5}$ ).

ANSWER	LOGIC
<p>1 <math>\text{C}_{18}\text{H}_{21}\text{NO}_3(\text{aq}) + \text{H}_2\text{O}(\text{l}) \rightleftharpoons \text{C}_{18}\text{H}_{22}\text{NO}_3^+(\text{aq}) + \text{OH}^-(\text{aq})</math></p>	<ul style="list-style-type: none"> <li>Write the equation for the dissociation of the base.</li> </ul>
$K_b = \frac{[\text{C}_{18}\text{H}_{22}\text{NO}_3^+][\text{OH}^-]}{[\text{C}_{18}\text{H}_{21}\text{NO}_3]}$	<ul style="list-style-type: none"> <li>Write the expression for <math>K_b</math>.</li> </ul>
<p><math>[\text{OH}^-] = 10^{-\text{pOH}}</math>  <math>[\text{OH}^-] = 10^{-4.05}</math>                      Therefore, <math>[\text{OH}^-] = 8.91 \times 10^{-5} \text{ mol L}^{-1}</math>.</p>	<ul style="list-style-type: none"> <li>Choose the correct formula to calculate the hydroxide ion concentration and insert the numbers.</li> </ul>
$K_b = \frac{[\text{OH}^-]^2}{[\text{C}_{18}\text{H}_{21}\text{NO}_3]} \quad ([\text{OH}^-] = [\text{C}_{18}\text{H}_{22}\text{NO}_3^+])$ $= \frac{[8.91 \times 10^{-5}]^2}{5.0 \times 10^{-3}} = 1.59 \times 10^{-6}$	<ul style="list-style-type: none"> <li>Insert numbers into the formula to calculate the <math>K_b</math> and calculate the answer. Assume <math>[\text{C}_{18}\text{H}_{21}\text{NO}_3]_{\text{initial}} = [\text{C}_{18}\text{H}_{21}\text{NO}_3]_{\text{equil}} = 5.0 \times 10^{-3}</math>.</li> </ul>
<p>2 <math>K_b = 1.6 \times 10^{-6}</math></p> <p><math>\text{NH}_3(\text{aq}) + \text{H}_2\text{O}(\text{l}) \rightleftharpoons \text{NH}_4^+(\text{aq}) + \text{OH}^-(\text{aq})</math></p>	<ul style="list-style-type: none"> <li>Write the dissociation equation.</li> </ul>
$K_b = \frac{[\text{NH}_4^+][\text{OH}^-]}{[\text{NH}_3]} = 1.8 \times 10^{-5}$	<ul style="list-style-type: none"> <li>Choose correct formula and insert numbers.</li> </ul>

ANSWER	LOGIC
pH = 10.6	$= \frac{[\text{OH}^-]^2}{[\text{NH}_3]}, \text{ as } [\text{OH}^-] = [\text{NH}_4^+]$ $[\text{OH}^-]^2 = 1.8 \times 10^{-5} \times [\text{NH}_3]$ $[\text{OH}^-] = \sqrt{(1.8 \times 10^{-5} \times 0.01)} = 4.2 \times 10^{-4}$ <ul style="list-style-type: none"> <li>▪ Determine pOH:  <math>\text{pOH} = -\log[\text{OH}^-]</math>  <math>= -\log(4.2 \times 10^{-4}) = 3.4</math></li> <li>▪ Determine pH:  <math>\text{pH} + \text{pOH} = 14</math>  <math>\text{pH} = 14 - \text{pOH} = 14 - 3.4 = 10.6</math></li> </ul>

#### TRY THESE YOURSELF

- 1 A  $0.38 \text{ mol L}^{-1}$  solution of the ascorbate ion ( $\text{HC}_6\text{H}_6\text{O}_6^-$ ) has a pOH of 5.15. Calculate the  $K_b$  for the ascorbate ion.
- 2 Determine the pH of a  $0.32 \text{ mol L}^{-1}$  of the phosphate ion ( $\text{PO}_4^{3-}$ ). ( $K_b = 5.9 \times 10^{-3}$ )

## INVESTIGATION 6.5

### Determining the $K_b$ for a weak base

#### INTRODUCTION

This investigation will involve using an ammonia solution.

You will be given the initial concentration of the ammonia solution and you will be able to determine the equilibrium concentration of the hydronium ion using the pH meter.

Hence, using the same methodology as was used in Investigation 6.4 (page 168) and Worked example 6.8 (page 174), you will be able to determine the equilibrium concentrations of the ammonium ion and the ammonia. Finally, you can use the equilibrium concentrations for all species to calculate the  $K_b$  for ammonia.

#### AIM

Write an aim for your investigation.

#### HYPOTHESIS

Write a suitable hypothesis for your investigation.

#### MATERIALS

- 100 mL  $0.100 \text{ mol L}^{-1}$  ammonia solution ( $\text{NH}_3$ )
- Add other materials that will be needed. Make sure you identify sizes of glassware that will be needed. Complete a risk assessment for your investigation.



Information and communication technology capability



Numeracy





WHAT ARE THE RISKS IN DOING THIS INVESTIGATION?	HOW CAN YOU MANAGE THESE RISKS TO STAY SAFE?
Chemicals may splash onto your skin or into your eyes.	



### METHOD

Devise a method to test your hypothesis.

**Hint:** Refer to Investigation 6.4 for ideas on a possible method.

Possible solutions that could be used are given in the table below.

SOLUTION	VOLUME/CHEMICAL
A	100 mL 0.100 mol L <sup>-1</sup> ammonia solution
B	25 mL solution A + 75 mL distilled water
C	10 mL solution A + 90 mL distilled water
D	25 mL solution C + 75 mL distilled water
E	10 mL solution C + 90 mL distilled water

### NOTE

- Always rinse the pipette with a small amount of the solution that you are putting in it.
- If you are re-using the volumetric flask, rinse with water before re-using it.
- Always rinse the pH meter with distilled water after use.
- Measure the pH of a solution before using it to make other solutions.

### RESULTS

Record results in an appropriately formatted table.

### ANALYSIS OF RESULTS

- Calculate the initial concentration of NH<sub>3</sub> for each solution (A–E).
- Draw a graph of pH versus initial [NH<sub>3</sub>].
- Use a spreadsheet program to draw a line of best fit for this graph and note the equation for the line of best fit.
- Use the equation for the line of best fit for an initial concentration value of NH<sub>3</sub> within the range for the investigation to determine the pH.
- Use the data in step 4 to determine the equilibrium concentration of the hydronium ion.
- Use the value for the hydronium ion's equilibrium concentration to determine the equilibrium concentrations for the hydroxide ion, ammonium ion and ammonia.
- Calculate the  $K_b$  for ammonia.

### DISCUSSION

$K_b$  for ammonia at 25°C is  $1.8 \times 10^{-5}$ .

Discuss your results with particular attention to the theoretical value given above.

### CONCLUSION

Write a conclusion based on the aim of this investigation.

### EXTENSION

Repeat the experiment to determine the temperature effect on  $K_b$  at 50°C.



- For a conjugate acid–base pair:  $K_a \times K_b = K_w$

## CHECK YOUR UNDERSTANDING

6.7

- 1 Define ' $K_b$ '.
- 2 Write the base dissociation equilibrium expressions for the following bases in water.
  - a  $\text{CN}^-$
  - b  $\text{HS}^-$
- 3
  - a Describe the relationship between strength of a base and the value of  $K_b$ .
  - b Describe the relationship between pOH and  $K_b$ .
- 4 Four unknown solutions (P, Q, R and S) were found to have the following  $K_b$  values respectively:  $9.1 \times 10^{-9}$ ,  $5.2 \times 10^{-4}$ ,  $5.8 \times 10^{-7}$ , and  $5.9 \times 10^{-4}$ . Arrange these in order of increasing base strength (weakest to strongest).
- 5 List any assumptions that are made when performing pOH, concentrations and  $K_b$  calculations involving weak bases.
- 6 A  $0.0534 \text{ mol L}^{-1}$  solution of a weak base (generic formula = B) has a pOH of 5.61. Calculate the  $K_b$  for this weak base.
- 7 What is the pH of a  $0.300 \text{ mol L}^{-1}$  solution of morphine? (Use  $K_b = 1.62 \times 10^{-6}$ )

## 6.8 Revisiting neutralisation

In chapter 5, you learnt that a neutralisation reaction occurs when an acid and a base react to form a salt and water. According to this definition, if the correct amounts of acid and base are mixed, then the resultant solution is neutral (neither acidic nor basic). However, it is only neutral when strong acids and strong bases react.

Definitions of acidic, basic and neutral solutions were given in section 6.4.

- An acidic solution is one in which  $[\text{H}_3\text{O}^+] > [\text{OH}^-]$ . At 298 K, this is when  $[\text{H}_3\text{O}^+] > 10^{-7} \text{ mol L}^{-1}$ .
- An alkaline solution is one in which  $[\text{H}_3\text{O}^+] < [\text{OH}^-]$ . At 298 K, this is when  $[\text{H}_3\text{O}^+] < 10^{-7} \text{ mol L}^{-1}$ .
- A neutral solution is one in which  $[\text{H}_3\text{O}^+] = [\text{OH}^-]$ . At 298 K, this is when the concentration of both species =  $10^{-7} \text{ mol L}^{-1}$ .

If an acid reacts with a base other than its conjugate base or water, it will always react completely, provided the reaction quantities meet the required stoichiometric ratios. This means that the same calculations are used to determine the amount needed for neutralisation for both weak and strong acids.

Determining the pH of the final solution for strong acids or strong bases is straightforward, as shown in Worked example 6.2 (page 160) and Worked example 6.4 (page 163). The pH determination for weak acids and bases is not so straightforward but can be calculated using the  $K_a$  or  $K_b$  values, as shown in Worked example 6.6 (page 167) and Worked example 6.8 (page 175).

The following worked example shows how to calculate the pH of the final solution when a strong acid and base react. Remember that sulfuric acid is diprotic and undergoes ionisation in two steps; however, when it is the limiting reagent, all of the protons will react.



### Revson

Check your understanding of acids, bases and pH.

### WORKED EXAMPLE (6.9)

If 55 mL of a  $0.70 \text{ mol L}^{-1}$  solution of NaOH was added to 75 mL of a  $0.22 \text{ mol L}^{-1}$  solution of  $\text{H}_2\text{SO}_4$ , then what would the pH of the final solution be?

ANSWER	LOGIC
$\text{H}_2\text{SO}_4(\text{aq}) + 2\text{NaOH}(\text{aq}) \rightarrow \text{Na}_2\text{SO}_4(\text{aq}) + 2\text{H}_2\text{O}(\text{l})$ or $\text{H}_3\text{O}^+ + \text{OH}^- \rightarrow 2\text{H}_2\text{O}$ (but remember that $\text{H}_2\text{SO}_4$ is diprotic)	<ul style="list-style-type: none"> <li>Write a balanced equation.</li> </ul>
$c(\text{NaOH}) = 0.70 \text{ mol L}^{-1}$ $V = 55 \text{ mL} = 0.055 \text{ L}$ $n = ?$ $0.70 = \frac{n}{0.055}$ $n(\text{NaOH}) = 0.70 \times 0.055 = 0.0385 \text{ mol}$ $c(\text{H}_2\text{SO}_4) = 0.22 \text{ mol L}^{-1}$ $V = 75 \text{ mL} = 0.075 \text{ L}$ $n = ?$ $0.22 = \frac{n}{0.075}$ $n(\text{H}_2\text{SO}_4) = 0.22 \times 0.075 = 0.0165 \text{ mol}$	<ul style="list-style-type: none"> <li>Calculate the number of moles of <math>\text{H}_2\text{SO}_4</math> and NaOH using <math>c = \frac{n}{V}</math>.</li> </ul>
$n(\text{NaOH}) = 0.0385 \text{ mol}$ $n(\text{OH}^-) = 0.0385 \text{ mol}$ $n(\text{H}_2\text{SO}_4) = 0.0165 \text{ mol}$ $n(\text{H}_3\text{O}^+) = 2 \times 0.0165 = 0.033 \text{ mol}$ ( $\text{H}_2\text{SO}_4$ can donate 2 protons) $\text{OH}^-$ is in excess by $0.0385 - 0.033 = 0.0055 = 5.5 \times 10^{-3} \text{ mol}$	<ul style="list-style-type: none"> <li>If the solution was neutral, then <math>[\text{H}_3\text{O}^+] = [\text{OH}^-]</math>. Determine which reactant is in excess.</li> </ul>
Using $c = \frac{n}{V}$ , $V = 55 \text{ mL} + 75 \text{ mL} = 0.130 \text{ L}$ $[\text{OH}^-] = \frac{5.5 \times 10^{-3}}{0.130} = 0.042 \text{ mol L}^{-1}$	<ul style="list-style-type: none"> <li>Calculate <math>[\text{OH}^-]</math>.</li> </ul>
$\text{pOH} = -\log [\text{OH}^-] = -\log(0.042) = 1.4$	<ul style="list-style-type: none"> <li>Calculate the pOH.</li> </ul>
$\text{pH} + \text{pOH} = 14$ $\text{pH} = 14 - 1.4 = 12.6$ $\text{pH} = 12.6$	<ul style="list-style-type: none"> <li>Calculate pH.</li> </ul>

#### TRY THESE YOURSELF

- What is the resultant pH when 50 mL of 0.1 M NaOH is added to 100 mL of 0.1 M HCl?
- How many grams of barium hydroxide is required to neutralise 500 mL of 0.2 M nitric acid?
- How much 0.1  $\text{mol L}^{-1}$  NaOH is required to neutralise 100 mL of 0.277 M ethanoic acid ( $\text{CH}_3\text{COOH}$ ) solution?

## INVESTIGATION 6.6

### Modelling neutralisation

#### INTRODUCTION

Neutralisation occurs when equal quantities of  $\text{H}_3\text{O}^+$  and  $\text{OH}^-$  ions are present in solution, irrespective of whether the ions are produced from strong or weak acids and bases. Provided the correct amounts of acid and base are used, the reaction will go to completion.

Neutralisation reactions can be demonstrated or modelled in a variety of ways. In this investigation there is the opportunity to demonstrate neutralisation through one of the following methods.

- Using an experiment
- Using molecular models
- Using an animation

#### AIM

To show neutralisation reactions in a variety of ways.

#### PART A: USING AN EXPERIMENT

##### MATERIALS

- 50 mL of  $1 \text{ mol L}^{-1}$  acid (for example, hydrochloric acid, acetic acid)
- 50 mL of  $1 \text{ mol L}^{-1}$  base (for example, sodium hydroxide, ammonium hydroxide)
- Distilled water
- Universal indicator and colour chart
- 10 mL measuring cylinder
- 5 test tubes and a test-tube rack
- Dropper
- Stirring rod
- Digital camera (optional)
- Safety glasses



##### WHAT ARE THE RISKS IN DOING THIS INVESTIGATION?

Sodium hydroxide is caustic and hydrochloric acid is corrosive.

##### HOW CAN YOU MANAGE THESE RISKS TO STAY SAFE?

Wear safety glasses and personal protective clothing. Avoid contact with skin. If spilt on skin, wash with plenty of water.

What other risks are associated with your investigation? How can you manage these?

##### METHOD

- Pour 5 mL of an acid into a clean test tube.
- Add one drop of universal indicator.
- Rinse the measuring cylinder with distilled water and fill to the 5 mL mark with a base.
- Add the base, drop by drop, to the test tube containing the acid. Stir constantly while adding the base. Continue adding until the colour of the solution matches the neutral colour on the universal indicator colour chart.
- Record the volume of base added.
- Repeat steps 1–5 with a different combination of acid and base.

##### RESULTS

Record the results in a table.

##### DISCUSSION

- Write balanced equations for the neutralisation reactions conducted.
- Were equal volumes of acid and base required to achieve a neutral solution? If not, suggest reasons for differences in volume.
- Explain how this investigation demonstrated neutralisation.



## » PART B: USING MOLECULAR MODELS

### MATERIALS

- Molecular model kit or similar substitute

### METHOD

- 1 Using a molecular model kit or other appropriate materials, construct two models of HCl and NaOH.
- 2 Rearrange one set of models to show the products of the reaction between HCl and NaOH.
- 3 Draw or take photos of the models, and annotate to provide an explanation of how this shows neutralisation.
- 4 Repeat steps 1–2 using models of different acids and bases.

### RESULTS

Record the results in an appropriately formatted table.

### DISCUSSION

- 1 Write balanced equations for the neutralisation reactions conducted.
- 2 Explain how this investigation demonstrated neutralisation, using annotated drawings or photos.

## PART C: USING AN ANIMATION

### MATERIALS

- Computer
- Appropriate software

### METHOD

Construct or research an animation that demonstrates neutralisation. See the weblink for an example.

### RESULTS

Record the results in a table.

### DISCUSSION

Use the animation to explain neutralisation.



Neutralisation reactions

## Salts: Not necessarily neutral

Another factor that influences the pH of the final solution is the salt produced after the reaction of an acid with a base. Salts are ionic compounds produced when an acid neutralises a base.

A solution of a salt may be acidic, basic or neutral. Earlier definitions of acids and bases could not explain why. However, the Brønsted–Lowry theory can explain it: the conjugate acids or bases (the ions) formed in the neutralisation reaction may react with the water in the solution to produce hydronium ions or hydroxide ions.

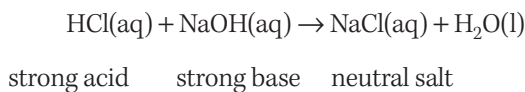
### Strength of conjugate acid–base pairs

In section 6.3, you learnt acids and bases can be classified as strong or weak depending on the degree to which the acid ionises or the base dissociates. In sections 6.6 and 6.7, you learnt about how  $K_a$  and  $K_b$  provide a quantitative measure for the strength of an acid and a base. This information can be used to determine the pH of the salt solution.

The strength of the conjugate acid or base produced is dependent on the strength of the original acid or base. Generally, a weaker acid will produce a stronger conjugate base, while a weaker base will produce a stronger acid. A strong acid will produce a weak or neutral conjugate base and a strong base will produce a weak or neutral conjugate acid.

Salts produced from the neutralisation reaction between a strong acid and strong base do not hydrolyse (react with water) and the pH of the solution will be neutral.

For example:



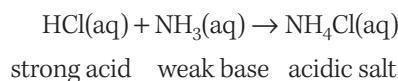
When the salt (NaCl) produced in this reaction is dissolved in water, it produces  $\text{Na}^+(\text{aq})$  and  $\text{Cl}^-(\text{aq})$ :



$\text{Na}^+$  does not react with water, so it will not affect the pH of the solution. HCl is a strong acid that produces  $\text{Cl}^-$  as its conjugate base. It is a considerably weak base, so it will not react to remove a proton from water. The resulting solution will be neutral (pH = 7).

When a strong acid and weak base react, the resulting solution will have a pH < 7. While the anion (conjugate base of the strong acid) produced will not affect the pH, the conjugate acid of the weak base (cation) will hydrolyse to produce  $\text{H}_3\text{O}^+$  so the solution will be acidic. For weak bases, the conjugate acid will react with water to form an acidic solution.

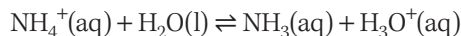
For example:



The ammonium chloride salt produced contains the ammonium cation and chloride anion:



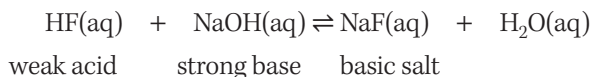
The chloride ion that had come from the strong acid does not affect the pH of the solution. However, the ammonium cation is the conjugate acid of a weak base. It will react with water (hydrolyse) to produce a hydronium ion according to the following reaction:



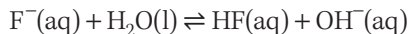
The resulting solution will be acidic (pH < 7).

When a weak acid and strong base react, the resulting solution will have a pH > 7. While the cation produced from the base will not affect the pH, the conjugate base of the weak acid (anion) will hydrolyse to produce  $\text{OH}^-$ , so the solution will be basic. For weak acids, the conjugate bases are stronger. They will then react with water to form a basic solution.

For example:



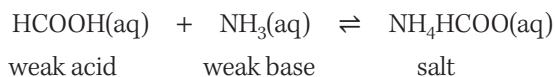
The salt dissociates into  $\text{Na}^+(\text{aq})$  and  $\text{F}^-(\text{aq})$ . The  $\text{Na}^+(\text{aq})$  cation does not affect the pH. However, the conjugate base of the weak acid will react with water to produce hydroxide ions:



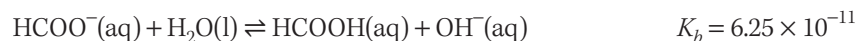
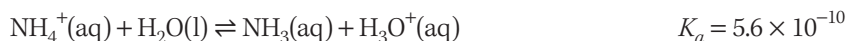
The resulting solution is basic (pH > 7).

The salts formed from reaction between a weak acid and a weak base will also react with water, as shown for the weak acids and bases in the examples above. Whichever salt is the stronger acid or base will determine whether the solution is acidic or basic. The  $K_a$  and  $K_b$  values from data tables will need to be compared to determine this.

For example:



The salt produces  $\text{NH}_4^+$  cation (conjugate of the weak base  $\text{NH}_3$ ) and  $\text{HCOO}^-$  anion (conjugate of the weak acid  $\text{HCOOH}$ ). The possible hydrolysis reactions are:



$K_a > K_b$ , so the solution will be acidic.

Table 6.8 gives examples of the pH of salts formed from reactions between strong and weak acids and bases.

**TABLE 6.8** pH of salts formed from reaction between different acids and bases

	STRONG BASE (e.g. NaOH)	WEAK BASE (e.g. NH <sub>3</sub> )
STRONG ACID (e.g. HCl)	pH = 7 (e.g. NaCl)	pH < 7 (e.g. NH <sub>4</sub> Cl)
WEAK ACID (e.g. CH <sub>3</sub> COOH)	pH > 7 (e.g. CH <sub>3</sub> COONa)	pH = ? (e.g. CH <sub>3</sub> COONH <sub>3</sub> ) Depends on the $K_a$ and $K_b$ of the cation and anion of the salt.

## Amphiprotic salts

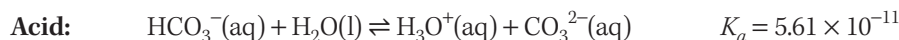
You have already learnt that water is amphiprotic, which means it can act as both an acid and a base; however, some salts are also amphiprotic.

Consider the salts sodium hydrogen carbonate (NaHCO<sub>3</sub>) and potassium dihydrogen phosphate (KH<sub>2</sub>PO<sub>4</sub>).

Both of these salts will dissociate in aqueous solution to produce the ions Na<sup>+</sup> and HCO<sub>3</sub><sup>-</sup> or K<sup>+</sup> and H<sub>2</sub>PO<sub>4</sub><sup>-</sup> respectively. In both cases, it is the anion that demonstrates the amphiprotic properties. While the Na<sup>+</sup> and K<sup>+</sup> are present in the solution, they are spectator ions since they do not react with water.

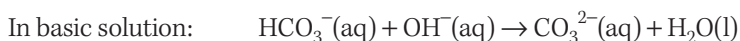
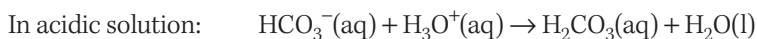
In aqueous solution, the amphiprotic substance acts as both an acid and a base. This means that it will both donate a proton (acid) to water and accept a proton (base) from water.

For example, when sodium hydrogen carbonate is dissolved in water, the following reactions occur simultaneously but only to a small extent:



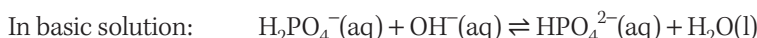
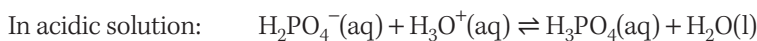
As can be seen from the  $K_a$  and  $K_b$  values, the  $K_a$  is slightly larger than the  $K_b$  value so the solution should have a pH < 7.

However, when placed in acidic or basic solutions the reactions go to completion.



In acidic solutions, the hydrogen carbonate ion (HCO<sub>3</sub><sup>-</sup>) acts as a base, accepting a proton from the hydronium ion to form its conjugate acid, carbonic acid (H<sub>2</sub>CO<sub>3</sub>). While in basic solutions, the hydrogen carbonate ion donates a proton, the hydroxide ion thus acting as an acid to form its conjugate base, carbonate ion (CO<sub>3</sub><sup>2-</sup>).

The dihydrogen phosphate ion (H<sub>2</sub>PO<sub>4</sub><sup>-</sup>) will act similarly in acidic and basic solutions.



Other examples of amphiprotic substances are the hydrogen sulfate ion (HSO<sub>4</sub><sup>-</sup>), hydrogen sulfite ion (HSO<sub>3</sub><sup>-</sup>) and the hydrogen sulfide ion (HS<sup>-</sup>).



Check your understanding



## INVESTIGATION 6.7

### Amphiprotic nature of salts

#### INTRODUCTION

When amphiprotic materials react with water, they can either donate or accept protons. Measuring the pH will determine if the solution is relatively acidic or basic, and therefore, which reaction is predominating.

At 25°C, if  $[H^+] > [OH^-]$ , then  $pH < 7$  and the substance acts as an acid. If  $[H^+] < [OH^-]$ , then  $pH > 7$  and the substance acts as a base.

The sodium salt for each sample is used. The  $Na^+$  ion is a spectator ion and will not play a role in the reactions.

#### AIM

To test salts for their acid and base strength.

#### MATERIALS

- 50 mL of 0.1 mol L<sup>-1</sup> NaHCO<sub>3</sub>
- 50 mL of 0.1 mol L<sup>-1</sup> NaHSO<sub>4</sub>
- 50 mL of 0.1 mol L<sup>-1</sup> Na<sub>2</sub>HPO<sub>4</sub>
- 50 mL of 0.1 mol L<sup>-1</sup> NaH<sub>2</sub>PO<sub>4</sub>
- Distilled water
- pH meter
- 100 mL beaker

Complete the risk assessment box to show any risks associated with completing this investigation and ways to manage them.



WHAT ARE THE RISKS IN DOING THIS INVESTIGATION?	HOW CAN YOU MANAGE THESE RISKS TO STAY SAFE?

#### METHOD

- Place 50 mL of one salt solution in a clean beaker.
- Use the pH meter to measure the pH.
- Record the pH value.
- Repeat steps 1–3 for each salt solution.

#### RESULTS

Construct an appropriate table to record the results.

#### ANALYSIS OF RESULTS

- Determine the  $[H_3O^+]$  for each sample.
- List the samples from the lowest pH to the highest pH.
- Which sample is the most acidic?
- Which sample is the most basic?



## » DISCUSSION

- 1 Write the reaction with water for each sample.
- 2 For each sample, decide if the salt solution was an acid or a base. Explain your reasoning.
- 3 Why could a pH meter not be used for this investigation?

## CONCLUSION

- 1 Compare the pH results obtained for each sample.
- 2 Are the salts acidic or basic?
- 3 Discuss whether the results allow the comparison of the acid and base strength of the amphiprotic salts.

- Strong monoprotic acids have very weak conjugate bases. Strong bases produce cations that do not affect the  $H^+$ . The salt formed when they react will produce a neutral solution.
- A salt formed from the reaction between a strong acid and weak base produces a cation, which is a weak acid, so the resulting solution will be acidic.
- The salt formed from the reaction between a weak acid and a strong base will produce an anion that is a weak base so the resulting solution will be basic.
- Salts from a weak acid and a weak base are formed from the conjugate base and a conjugate acid. The cation and anion of the resulting salt will hydrolyse and the pH of the resulting solution will depend on the  $K_a$  and  $K_b$  of the conjugates.

- 1 Explain what is required for a solution to be neutral.
- 2 What is the resultant pH when:
  - a 50 mL of  $0.2 \text{ mol L}^{-1}$  HCl is added to 75 mL of  $0.1 \text{ M Ca(OH)}_2$ ?
  - b 25 mL of  $0.015 \text{ mol L}^{-1}$  potassium hydroxide is added to 50 mL of  $0.012 \text{ mol L}^{-1}$  nitric acid?
  - c a solution is produced by measuring  $3.50 \times 10^{-3}$  moles of NaOH and  $2.50 \times 10^{-4}$  moles of  $H_2SO_4$  into a container then water is added until the final volume is 1.00 L?
- 3 Explain, using examples, why the reaction between a strong acid and strong base produces a neutral salt, while the reaction between a strong acid and weak base produces a salt that is acidic.
- 4 For each of the following salts:
  - i potassium carbonate
  - ii ammonium nitrate
  - iii sodium sulfate
  - a write a reaction for its formation
  - b identify whether it will have a pH equal to 7, less than 7 or greater than 7, giving a reason.
- 5  $HS^-$  is amphiprotic. Write equations showing its reactions with each of the following.
  - a Water
  - b Hydrochloric acid
  - c Sodium hydroxide
- 6 An aquarium was at the correct pH when a young child poured a 500 mL bottle of vinegar into it. The label on the bottle showed the vinegar in the bottle to be a  $0.83 \text{ mol L}^{-1}$  solution of acetic acid ( $CH_3COOH$ ).
  - a How was the pH of the aquarium changed as a result of this action?
  - b How many grams of sodium hydroxide would need to be added to the aquarium to neutralise the excess acid?

## CHECK YOUR UNDERSTANDING

6.8

# 6 CHAPTER SUMMARY

## IMPORTANT NEW TERMS

After studying this chapter you should know the meaning of the following terms:

acidic solution (p. 159)

alkaline solution (p. 159)

conjugate acid (p. 145)

conjugate base (p. 145)

conjugate pair (p. 145)

diprotic (p. 157)

dissociation reaction (p. 152)

ionisation reaction (p. 152)

molarity (p. 152)

monoprotic (p. 157)

neutral solution (p. 159)

percentage ionisation (p. 170)

pH scale (p. 146)

polyprotic (p. 157)

self-ionisation constant ( $K_w$ ) (p. 159)

strong acid (p. 152)

strong base (p. 153)

triprotic (p. 157)

universal indicator (p. 148)

## AFTER STUDYING THIS CHAPTER YOU SHOULD KNOW:

- the definitions for all terms in the important new terms list
- the pH scale is based upon the self-ionisation of water ( $K_w$ )
- the self-ionisation constant for water
- the definition of pH and pOH and the relationship between them
- relationship between pH and acid or base strength
- how dilution affects pH
- acids can be classified as monoprotic or polyprotic depending on the number of protons donated by each molecule of the acid
- the Brønsted–Lowry definition of acids and bases
- acid donates a proton to form the conjugate base; a base accepts a proton to form the conjugate acid
- amphiprotic salts can both accept and donate a proton
- concentration of a solution refers to amount in a certain volume
- if an acid reacts with a different base (not the conjugate base and not water), it will always react 100%; this means that the same calculations are used to determine the amount needed for neutralisation for both weak and strong acids
- the strength of an acid refers to the ability of the acid to donate a proton in water
- the strength of a base refers to the ability to accept a proton from water

## YOU SHOULD BE ABLE TO:

- construct models or animations to communicate the differences between strong, weak, concentrated and dilute acids and bases
- represent acid–base reactions as equilibrium equations, determining the expressions for the acid dissociation equilibrium constant  $K_a$  and  $pK_a$  for both monoprotic and polyprotic acids
- recognise and write equations for conjugate acid and base pairs
- write equations to show the amphiprotic nature of some ions
- calculate the pH of solutions of strong acids and bases, and by using  $K_a$  values
- calculate the pH of weak acid and base solutions
- calculate the percentage ionisation for a weak acid given the pH and  $K_a$
- predict the pH of a weak acid or base given the concentration and  $K_a$  or  $K_b$
- represent ionisation, dissociation and the reactions of weak acids and bases using chemical equations
- model neutralisation
- calculate the pH of the resultant solution produced when strong acids and bases are mixed
- predict whether a salt will produce an acidic, basic or neutral solution.

## AFTER STUDYING THIS CHAPTER YOU SHOULD KNOW:

- strong acids completely ionise in water and have a large equilibrium constant ( $K_a$ ); weak acids have a small  $K_a$  and do not as readily ionise
- the value of  $pK_a$  gives a measure of acid strength
- strong bases completely dissociate in water and have a large equilibrium constant ( $K_b$ ); weak bases have a small  $K_b$  and do not as readily dissociate
- salts produced by reactions of acids and bases may produce acidic, basic or neutral solutions depending on the strength of the reacting acids and bases.

# 6 CHAPTER REVIEW QUESTIONS



Review quiz

- Construct a flow chart to show the relationships between pH, pOH,  $K_w$ , hydrogen ion and hydroxide ion concentrations.
- Explain the difference between strength and concentration with respect to acids and bases.
  - List three different measures that can be used to compare strength of acids or bases, and any limitations of these.
- What colour would you expect to see in a piece of litmus paper to which the following have been added?
  - 1 drop of  $\text{Ca}(\text{OH})_2(\text{aq})$
  - 1 drop of  $\text{HF}(\text{aq})$
  - 1 drop of  $\text{NaNO}_3(\text{aq})$
- Milk has a pH of 6.5. This means that milk is:
  - strongly acidic.
  - slightly acidic.
  - slightly basic.
  - strongly basic.
- If tomato juice has a pH of 5 and orange juice has a pH of 3, then:
  - orange juice is twice as acidic as tomato juice.
  - tomato juice is twice as acidic as orange juice.
  - orange juice is 100 times more acidic than tomato juice.
  - tomato juice is 100 times more acidic than orange juice.
- Write the ionic equations to show the ionisation of the following acids in water.
    - Nitric acid
    - Acetic acid
  - Write the dissociation reaction for the following bases in water.
    - Sodium oxide
    - Ammonia
- State the names and formulae of two polyprotic acids.
  - Write the ionisation equations for the two-step ionisation of one of these acids.
  - Identify the conjugate acid–base pairs in each equation.
- Calculate the pH and pOH of the following solutions.
  - $0.050 \text{ mol L}^{-1} \text{ HCl}(\text{aq})$
  - $0.020 \text{ mol L}^{-1} \text{ NaOH}(\text{aq})$
  - 40.0 mL of  $0.200 \text{ mol L}^{-1}$  hydrochloric acid solution that reacts with 20.0 mL of a  $0.100 \text{ mol L}^{-1}$  sodium hydroxide solution
- The volume of solution in column A was diluted to the volume in column B. Calculate the pH of the diluted solution for each of the three solutions.

	COLUMN A	COLUMN B
a	50 mL hydrochloric acid (pH = 0.62)	500 mL
b	25 mL of $0.152 \text{ mol L}^{-1}$ nitric acid	2.0 L
c	10 mL of $0.114 \text{ mol L}^{-1}$ sodium hydroxide	250 mL

- 10** A  $0.25 \text{ mol L}^{-1}$  solution of sodium hydrogen sulfate has a pH of 1.31 at  $25^\circ\text{C}$ . Calculate the acid dissociation constant ( $K_a$ ) for the hydrogen sulfate ion.
- 11** A  $0.10 \text{ mol L}^{-1}$   $\text{NH}_3$  solution has a pH of 11. Calculate the base dissociation constant ( $K_b$ ) for ammonia.
- 12** What mass of sodium hydroxide must be dissolved in water to produce 750 mL of solution with pH 13?
- 13** Write all the equilibrium expressions for the ionisation of phosphoric acid. The  $K_a$  values are  $7.5 \times 10^3$ ,  $6.2 \times 10^{-8}$  and  $2.2 \times 10^{-13}$ . Describe the trend in the size of the  $K_a$  values.
- 14**
- Write the equilibrium expression for citric acid as it reacts with water.
  - Explain the effect of the addition of acid on a solution of citric acid. How is the pH affected?
  - Explain what occurs when the citric acid solution is diluted by a factor of 10. How could this be determined experimentally?
- 15**
- A student is investigating an equilibrium mixture produced by reacting methanoic acid ( $\text{HCOOH}$ ) with water. They find that the pH of the solution is 2.40 and the concentration of  $\text{HCOOH}$  is  $0.10 \text{ mol L}^{-1}$ . Calculate the  $K_a$  of methanoic acid.
  - A pH meter was placed in a beaker containing 200 mL of  $0.00100 \text{ mol L}^{-1}$  hypochlorous acid ( $\text{HOCl}$ ). The pH was 5.3. Calculate the  $K_a$  for hypochlorous acid.
- 16** Predict whether the pH of each of the following salts placed in water is acidic, basic or neutral.
- $\text{NaCH}_3\text{COO}$
  - $\text{KCN}$
  - $\text{NH}_4\text{NO}_3$
- 17** Boric acid ( $\text{H}_3\text{BO}_3$ ) is a weak acid. Its conjugate base, the borate ion, exists as  $\text{B}(\text{OH})_4^-$ .

A solution of pure sodium borate,  $\text{NaB}(\text{OH})_4$ , is prepared in water at  $25^\circ\text{C}$ . The borate ion dissociates according to the equation:

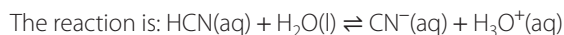


- Give the equilibrium expression for this reaction.

At equilibrium, the concentration of  $\text{B}(\text{OH})_4^-$  was exactly  $0.1 \text{ mol L}^{-1}$  and the pH was determined to be 11.11.

- Calculate the hydrogen ion and hydroxide ion concentrations in the solution.
- Calculate the  $\text{H}_3\text{BO}_3$  concentration.
- Calculate the  $K_a$  of boric acid.
- Calculate the  $\text{p}K_a$  of boric acid.

- 18** Hydrogen cyanide gas is highly toxic. It dissolves in water to form a weak acid.



The acid dissociation constant is  $6.3 \times 10^{-10}$ .

- Write the expression for the acid dissociation constant.
  - Calculate the pH of a solution of HCN of concentration  $0.00010 \text{ mol L}^{-1}$ .
  - Calculate the percentage ionisation of the HCN solution at this concentration.
  - The mining industry uses solutions of HCN to extract gold. Explain why the solutions are always kept above pH 7.
- 19** The weak acid hydrogen sulfide ( $\text{H}_2\text{S}$ ) reacts with  $\text{NH}_3$  to produce the salt  $\text{NH}_4\text{HS}$ . ( $K_a(\text{NH}_4^+) = 5.7 \times 10^{-10}$ ;  $K_a(\text{H}_2\text{S}) = 1 \times 10^{-7}$ )
- Write the equations for the reactions of the salt cations and anions with water.
  - Calculate  $K_b$  for  $\text{HS}^-$  (**Hint:** For conjugate acid–base pairs  $K_a \times K_b = K_w$ ).
  - Predict if the solution will be acidic, basic or neutral.
- 20** Calculate the pH of the solution that results when 40.0 mL of  $0.100 \text{ mol L}^{-1}$   $\text{NH}_3$  ( $K_b = 1.77 \times 10^{-5}$ ) is:
- diluted with 20.0 mL of distilled water
  - mixed with 30.0 mL of 0.200 M HCl solution.

# 7 Using quantitative analysis

## INQUIRY QUESTION

How are solutions of acids and bases analysed?

### Students:

conduct practical investigations to analyse the concentration of an unknown acid or base by titration **ICT N**

investigate titration curves and conductivity graphs to analyse data to indicate characteristic reaction profile, for example: **ICT**

- strong acid/strong base
- strong acid/weak base
- weak acid/strong base **ACSCH08, ACSCH02**)

explore acid/base analysis techniques that are applied:

- in industries
- by Aboriginal and Torres Strait Islander Peoples **ATSIHC**
- using digital probes and instruments **ICT**

conduct a chemical analysis of a common household substance for its acidity or basicity **ACSCH08**) for example: **ICT N**

- soft drink
- wine
- juice
- medicine

conduct a practical investigation to prepare a buffer and demonstrate its properties **ACSCH08**) **ICT N**

describe the importance of buffers in natural systems. **ACSCH09, ACSCH02**)

Chemistry Stage 6 Syllabus © NSW Educational Standard Authority for and on behalf of the Crown in right of New South Wales, 2017







Determining whether or not a chemical reaction has occurred is a form of qualitative analysis – it gives a ‘yes/no’ answer. However, there are times when chemists want not only to know whether a chemical reaction occurs, but they also want to be able to quantify the reaction. For this, they need to be able to perform **quantitative analysis**. There are many different methods that chemists use to quantify a sample and these can be broadly classified as chemical methods or physical methods.

Physical methods involve the measurement of a physical property such as solubility, absorption of light and density. Various types of spectroscopic methods (infrared, UV, NMR, atomic emission), and chromatography are examples of physical methods. You will learn about these in Module 8.

Chemical methods involve using chemical reactions to form new chemical compounds. Volumetric, gravimetric and combustion analysis are examples of chemical quantitative methods.

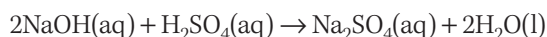


**FIGURE 7.1** Student conducting a volumetric analysis experiment

## 7.1 Volumetric analysis – the basics

**Volumetric analysis** is one chemical analysis method that is widely used in industry. Volumetric means measuring volumes. Hence, volumetric analysis involves determining the concentration of a sample by measuring the volume of this sample that reacts with a known volume of another substance of known concentration.

**Titration** is the main technique for volumetric analysis. This involves determining the **equivalence point**. Consider the following reaction:



The mole ratio indicates that 2 moles of sodium hydroxide react with 1 mole of sulfuric acid. The equivalence point is the point at which there are twice as many moles of sodium hydroxide present as there are moles of sulfuric acid. This is because 1 mole of sulfuric acid produces 2 moles of hydrogen ions ( $\text{H}^+$ ) and 2 moles of sodium hydroxide produce 2 moles of hydroxide ions ( $\text{OH}^-$ ). Therefore, there are an equal number of moles of hydrogen ions and hydroxide ions. Hence, the equivalence point is the point at which the reactants are present in the mole ratio given in the balanced equation for the reaction.



Prior knowledge

In the reaction on the previous page, both solutions are clear, as are the products. It is not possible to see when the equivalence point has been reached. As you learnt in chapter 6, acid–base indicators change colour within certain pH ranges. An acid–base indicator is added to determine when the **end point** has been reached. The end point is indicated by a change in colour of the indicator.

Titration uses specialist glassware and the end point can be detected by a variety of methods, such as the use of acid–base indicators, conductivity and pH probes. Chemists must have an understanding of the chemistry of the specific reaction to determine the most appropriate way to ascertain the end point.

## Specialised glassware

Volumetric analysis involves the measuring of volumes, so you need to use glassware with accurate measuring scales. The most common types of glassware are volumetric flasks, burettes and pipettes. Since **accuracy** is very important in this technique, you must minimise **parallax error** by ensuring that when reading the volume, the measuring line is directly in line with your eye level. You can see the effect your eye level has on the reading in Figure 7.2.

### Volumetric flask

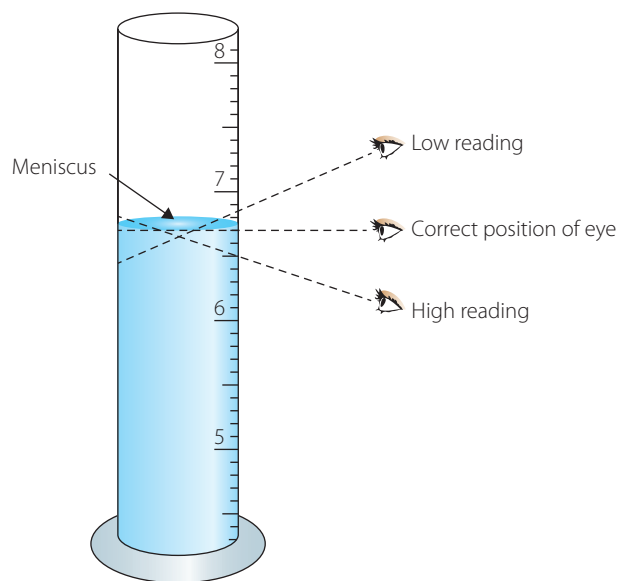
A volumetric flask is a flat-bottomed flask with a long narrow neck (Figure 7.3). You used these in Year 11 for accurately diluting a solution. Volumetric flasks are available in a variety of sizes but the most commonly used in schools are the 100 mL and 250 mL volumetric flasks. A line on the flask indicates the volume that can be accurately measured. The volumetric flask is always rinsed with the solvent, generally water, prior to use.

Once the flask has been rinsed with the solvent, pour the solution into the flask and top it up to the line with a wash bottle or a Pasteur pipette – a dispenser with a fine tip to add small drops. The bottom of the meniscus must be just touching the line on the flask. It is important not to overfill the flask, because then the volume of solution will not be accurately known. If this happens, you will need to empty the flask and start again from the beginning.

### Burette

A burette is a long, narrow glass tube with a tap at the bottom. The most commonly used burette is a 50 mL burette. The measuring scale on a burette is inverted, since it measures the volume of solution that leaves the burette through the tap. Hence, the zero position is at the top of the burette and the 50 mL position is near the bottom of the burette. You can see this in Figure 7.4. The burette is always rinsed with the solution that will be placed in the burette prior to use.

To rinse the burette, pour a small volume of solution into the burette. Then, holding the burette horizontally, open the tap and turn the burette slowly in your hands so that all surfaces on the inside of the burette are rinsed with the solution. Empty this solution.



**FIGURE 7.2** How to read a measurement line to avoid parallax error



**FIGURE 7.3** A volumetric flask



**FIGURE 7.4** A burette

#### Methodology for using specialised glassware

Descriptions, diagrams and step-by-step videos of using glassware

To fill the burette, place it back in the burette clamp and close the tap. Pour the solution into the burette until it is above the zero mark. Place a flask under the burette and open the tap so that the airlock below the tap is filled with solution. Adjust the volume of solution in the burette to the zero mark.

## Pipette

A pipette is a thin glass tube that accurately measures a fixed volume of solution. The most common used in school laboratories are 20 mL and 25 mL pipettes, as shown in Figure 7.5. A line on the pipette indicates the volume that can be accurately measured. The pipette is always rinsed with the solution that will be placed in it prior to use.

To rinse the pipette, use a pipette filler to draw up a small volume of solution. Remove the pipette filler, hold the pipette horizontally and turn the pipette in your hands so that all surfaces on the inside of the pipette are rinsed with the solution. Empty this solution.

To fill the pipette, use the pipette filler to draw the solution into the pipette. Stop when the volume of solution is above the line on the pipette. Slowly evacuate the solution until the bottom of the meniscus is just touching the line. Place the pipette over the flask into which the solution will be evacuated, remove the pipette filler and allow the pipette to empty. Tap the tip of the pipette on the inside of the flask. A small volume of solution will remain in the pipette – do not try to evacuate this solution. The pipette has been calibrated to evacuate the specified volume when it empties naturally under gravity.

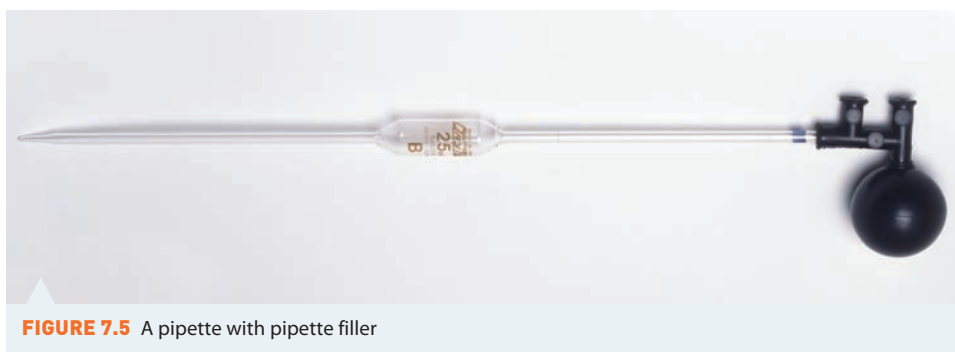


FIGURE 7.5 A pipette with pipette filler

## INVESTIGATION 7.1

### Practising rinsing and reading measurements on glassware

#### INTRODUCTION

Volumetric flasks, burettes and pipettes are used to measure accurate volumes. Hence, you need to learn to use this equipment correctly and to read the scales to benefit from using this equipment.

#### AIM

To read volumes accurately using volumetric flasks, burettes and pipettes.

#### MATERIALS

- 100 mL or 250 mL volumetric flask with lid
- 20 mL or 25 mL pipette
- Pipette filler



- » ■ Burette
- Burette clamp or bosshead and retort clamp
- Retort stand
- 250 mL conical flask
- 250 mL beaker
- 150 mL beaker
- Wash bottle or Pasteur pipette and bulb
- Filter funnel
- Water

WHAT ARE THE RISKS IN DOING THIS INVESTIGATION?	HOW CAN YOU MANAGE THESE RISKS TO STAY SAFE?
Glassware may break and cut you.	Always ensure that glassware is kept away from the edge of benches. If glassware does break, inform your teacher immediately.



What other risks are associated with this investigation? How can you manage these?

#### METHOD

##### PART A: VOLUMETRIC FLASK

- 1 Rinse the volumetric flask with a small volume of water, then empty it.
- 2 Place a filter funnel in the neck of the volumetric flask.
- 3 Use a 250 mL beaker to pour water through the filter funnel into the flask. Hold the filter funnel slightly above the flask so that the water will flow freely.
- 4 When the bulb of the flask is filled, remove the filter funnel and use a wash bottle or Pasteur pipette to fill the flask so that the bottom of the meniscus is touching the line marked on the flask.
- 5 Check your result with your teacher.

##### PART B: BURETTE

- 1 Clamp the burette to a retort stand using a burette clamp and close the tap on the burette.
- 2 Place a filter funnel into the burette and pour a small volume of water into the burette.
- 3 Remove the filter funnel then remove the burette from the burette clamp, hold it horizontally, open the tap and turn the burette so that all surfaces of the burette are rinsed.
- 4 Empty the water into the sink.
- 5 Clamp the burette to the retort stand and close the tap on the burette.
- 6 Place a filter funnel into the burette and use a 150 mL beaker to fill the burette with water above the zero line. Remove the filter funnel.
- 7 Open the tap to allow water to flow to remove the air lock, and then close the tap.
- 8 Adjust the water level in the burette to the zero mark.
- 9 Place a flask under the burette and release exactly 26.30 mL from the burette.
- 10 Check your result by showing your teacher.
- 11 Refill your burette and adjust the water level in the burette to the zero mark.
- 12 Place a flask under the burette and release exactly 15.70 mL from the burette.
- 13 Check your result with your teacher.

##### PART C: PIPETTE

- 1 Attach the pipette filler to the pipette and draw up a small volume of water into the pipette.
- 2 Hold the pipette horizontally, remove the pipette filler and turn the pipette so that all surfaces of the pipette are rinsed.
- 3 Empty the pipette.



- » 4 Attach the pipette filler to the pipette and draw water into the pipette until the volume is above the line marked on the pipette.
- 5 Adjust the volume until the bottom of the meniscus touches the line marked on the pipette.
- 6 Check your result with your teacher.
- 7 Place the pipette over the 250 mL conical flask and remove the pipette filler so that the pipette empties into the flask. Tap the tip of the pipette on the inside wall of the flask and rinse down the sides of the flask with water.

#### RESULTS

Record your results in a table, including equipment, volume and comments by your teacher.

#### ANALYSIS OF RESULTS

- 1 Compare your results with those of other students in the class.
- 2 Comment on the accuracy of your results.

#### DISCUSSION

- 1 Discuss any common sources of error in the class results.
- 2 Describe ways to overcome these sources of error.

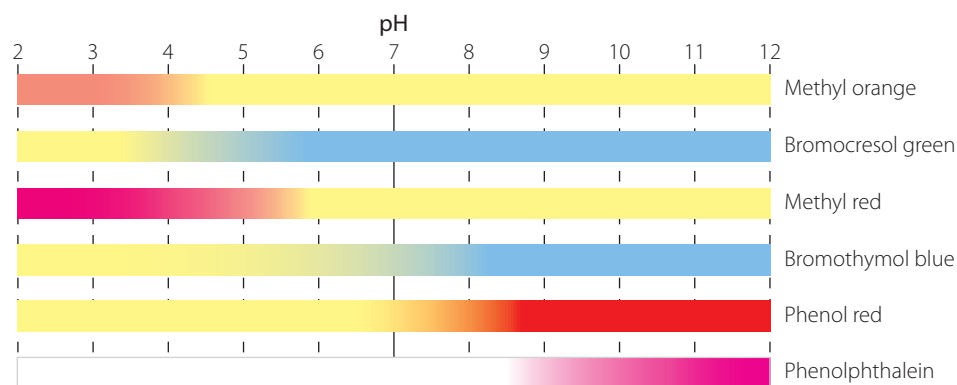
## Identifying the end point – indicators

During volumetric analysis, you need to be able to determine when the equivalence point has been reached. The physical sign that the equivalence point has been reached is called the ‘end point’. A simple way of observing the end point for an acid–base reaction is the use of an acid–base indicator. Acid–base indicators are used to visually show when a particular pH is passed. Different indicators change colour at different pH ranges, as shown in Table 7.1 and Figure 7.6. You were introduced to different acid–base indicators in chapters 5 and 6.

Acid–base indicators contain weak acids where the acid has a different colour from its conjugate base. As you learnt, some indicators are found in nature, while others are synthesised in the laboratory. Universal indicator is a mixture of indicators; therefore, it has a number of colour changes over the pH range of 1–14.

**TABLE 7.1** Common indicators and their pH ranges

INDICATOR	COLOUR CHANGE (FROM LOW pH TO HIGH pH)	pH RANGE
Methyl orange	Red–yellow	3.1–4.4
Bromocresol green	Yellow–blue	3.8–5.4
Methyl red	Pink–yellow	4.4–6.0
Bromothymol blue	Yellow–blue	6.2–7.6
Phenol red	Yellow–red	6.8–8.4
Phenolphthalein	Colourless–red	8.3–10.0



**FIGURE 7.6** Colours of some common indicators over ranges of pH

- Volumetric analysis involves determining the concentration of a sample by measuring the volume of this sample that reacts with a known volume of another substance of known concentration.
- Volumetric analysis involves using specialised glassware with accurate measuring scales.

- Define the following terms.
  - Volumetric analysis
  - Accuracy
  - Parallax error
- Explain the difference between end point and equivalence point.
- What is used to rinse a pipette?
  - Explain why is this used.
- Draw a scientific diagram of a volumetric flask.
- Explain why it is significant that universal indicator changes colour several times over the pH range 1–14?
- Describe how parallax error can be minimised.
- A student wanted to fill a burette with hydrochloric acid. They poured some water into the burette, then opened the tap and emptied the burette. The student then filled the burette with hydrochloric acid, adjusted the volume to the zero mark and indicated that they was ready to use the burette. Identify errors in the student's method and justify the correct method for using a burette.
- A student used three indicators to determine the pH of a sample of water from the local river. The results were colourless in phenolphthalein, yellow in methyl orange and blue in bromothymol blue. Use Figure 7.6, to determine whether the sample of river water was acidic, basic or neutral.
  - Explain how you came to that conclusion.

CHECK YOUR UNDERSTANDING

7.1

## 7.2 Primary standard solutions

To accurately determine the concentration of an unknown solution, it is titrated against a solution with an accurately known concentration. Accuracy is the number of significant figures to which a quantity is known. Some mass balances measure to the nearest gram, while others measure to the nearest milligram (0.001 gram). The mass balance that can measure to the nearest milligram is a more accurate



measuring device than the mass balance that measures to the nearest gram. Accuracy is determined by the measuring instrument that is used.

A chemical that can be made up into a solution of accurately known concentration is called a **primary standard**. A primary standard must be stable over a long time and under common laboratory conditions. A primary standard must also:

- ▶ have a large molar mass so that a reasonable mass is measured (hence, there is a smaller percentage error)
- ▶ be cheap so that it is affordable for use
- ▶ be of high purity so that no side reactions occur
- ▶ be stable in the presence of air (so that no reaction with air occurs)
- ▶ not have any water of hydration, which may change due to atmospheric conditions such as humidity
- ▶ dissolve readily in solvent (generally water) to form a stable solution.

Anhydrous sodium carbonate ( $\text{Na}_2\text{CO}_3$ ) and sodium hydrogen carbonate ( $\text{NaHCO}_3$ ) are frequently used as primary standards in school science laboratories since they meet all of the criteria.

## INVESTIGATION 7.2

### Making a primary standard solution

#### INTRODUCTION

Primary standard solutions have an accurately known concentration and are stable over a period of time in common laboratory conditions. These solutions are the starting point for the volumetric analysis so it is important that their concentration is accurate.

#### AIM

To make a primary standard solution.

#### MATERIALS

- 250 mL volumetric flask with lid
- Electronic balance
- Clean, dry 150 mL beaker
- Spatula
- Approximately 1.5 g anhydrous sodium carbonate
- 300 mL distilled water
- Wash bottle filled with distilled water
- Filter funnel
- Stirring rod
- Disposable droppers
- Safety glasses

#### WHAT ARE THE RISKS IN DOING THIS INVESTIGATION?

Solid sodium carbonate can irritate skin and eyes.

#### HOW CAN YOU MANAGE THESE RISKS TO STAY SAFE?

Wear safety glasses and wash your hands at the end of the experiment.

What other risks are associated with this investigation? How can you manage these?

#### METHOD

- 1 Rinse the volumetric flask with a small volume of distilled water.
- 2 Place a clean, dry 150 mL beaker on the electronic balance and **tare** the balance.
- 3 Accurately measure out, to the nearest 0.001 g, about 1.4 g of anhydrous sodium carbonate into the beaker.



Numeracy



- » 4 Add about 80 mL of distilled water to the beaker and stir until the sodium carbonate has completely dissolved.
- 5 Place the filter funnel into the neck of the volumetric flask.
- 6 Pour the sodium carbonate solution into the volumetric flask.
- 7 Pour a small volume of distilled water into the beaker, swirl and pour into the volumetric flask. Repeat three times.
- 8 Rinse the filter funnel by pouring some distilled water from the wash bottle into the volumetric flask.
- 9 Remove the filter funnel.
- 10 Fill the volumetric flask with distilled water until the bottom of the meniscus is just touching the line on the volumetric flask.
- 11 Place a lid on the volumetric flask, hold the lid in place, invert and swirl the contents of the flask so that mixing occurs.
- 12 Label your solution and keep it for use in Investigation 7.3 (page 201).

### RESULTS

Accurately record the mass of anhydrous sodium carbonate that was measured out.

### ANALYSIS OF RESULTS

Calculate the concentration of the sodium carbonate solution. Your answer should be given to four significant figures.

### DISCUSSION

- 1 Justify why the beaker and filter funnel were rinsed after use.
- 2 Evaluate the accuracy of this technique for preparing a primary standard.
- 3 Sodium carbonate decahydrate ( $\text{Na}_2\text{CO}_3 \cdot 10\text{H}_2\text{O}$ ) is readily available, has a higher molar mass and is cheaper than anhydrous sodium carbonate. Justify why anhydrous sodium carbonate is used as a primary standard, while sodium carbonate decahydrate is not.

- Accuracy is the number of significant figures to which a quantity is known. It is determined by the measuring instrument that is used.
- A chemical that can be made up into a solution of accurately known concentration is called a primary standard.

- 1 Identify three criteria that must be met for a substance to be used as a primary standard.
- 2 Describe the purpose of a primary standard.
- 3 Explain why sodium hydroxide is not appropriate for use as a primary standard.
- 4 Use your knowledge of the nature of hydrochloric acid to explain why it should not be used as a primary standard.
- 5 A student was making the following primary standard: 250 mL of a  $0.135 \text{ mol L}^{-1}$  solution of sodium hydrogen carbonate.
  - a Calculate the mass of sodium hydrogen carbonate that must be used to make this solution.
  - b Describe the method used to make this primary standard.
- 6 A student wanted to measure 90 mL of a solution. Suggest what piece (or pieces) of measuring equipment s/are most appropriate for this task and explain why.

### CHECK YOUR UNDERSTANDING

7.2

## 7.3 Performing volumetric analysis

The solution in the burette is called the **titrant**. The solution to be analysed – the solution with the unknown concentration – is called the **analyte**.

The most common titration conducted in a school science laboratory is the acid–base titration. The basic technique for performing a titration is as follows:

- One of the solutions will have an accurately known concentration.
- Place one of the solutions in the burette. The acid is generally placed in the burette since bases have the capacity to etch the glass and, over time, change the volume of the burette.
- Use a pipette to transfer a known volume of the other solution to a conical flask that has been rinsed with distilled water.
- Add two drops of an appropriate acid–base indicator (see page 194) to the solution in the conical flask.
- Slowly add the solution from the burette to the conical flask until the indicator just shows the first permanent colour change.
- Record the volume of solution added from the burette.
- Repeat the experiment several times until the volume of solution added from the burette is consistent to within about one-third of a division (0.03 mL). The second and subsequent titrations should involve slowing the rate of flow of solution from the burette to dropwise and parts of drops when near the end point. Use the average titre for the most accurately known titrations for your calculations.
- Write a balanced chemical equation and use mole calculations to determine the concentration of the unknown solution.

### WORKED EXAMPLE 7.1



Numeracy

Potassium hydrogen phthalate ( $\text{KH}(\text{C}_8\text{H}_4\text{O}_4)$ ) is a good primary standard for standardising alkali solutions. It contains one acidic hydrogen per formula unit. Potassium hydrogen phthalate (0.917 g) was dissolved in water and titrated with approximately  $0.2 \text{ mol L}^{-1}$  sodium hydroxide solution; 27.2 mL of sodium hydroxide solution was needed to reach the end point. Calculate the accurate molarity of the hydroxide solution.

ANSWER	LOGIC
$\text{KH}(\text{C}_8\text{H}_4\text{O}_4)(\text{aq}) + \text{NaOH}(\text{aq}) \rightarrow \text{Na}^+(\text{aq}) + \text{K}(\text{C}_8\text{H}_4\text{O}_4)^-(\text{aq}) + \text{H}_2\text{O}(\text{l})$	<ul style="list-style-type: none"> <li>▪ Write a balanced chemical equation for the reaction.</li> </ul>
$n_{\text{KH}(\text{C}_8\text{H}_4\text{O}_4)} = \frac{m_{\text{KH}(\text{C}_8\text{H}_4\text{O}_4)}}{M_{\text{KH}(\text{C}_8\text{H}_4\text{O}_4)}} = \frac{0.917}{204.22} = 0.00449 \text{ mol}$	<ul style="list-style-type: none"> <li>▪ Calculate the number of moles of potassium hydrogen phthalate that reacted with the sodium hydroxide.</li> </ul>
$C_{\text{NaOH}} = \frac{n_{\text{NaOH}}}{V_{\text{NaOH}}} = \frac{0.00449}{0.0272} = 0.165 \text{ mol L}^{-1}$	<ul style="list-style-type: none"> <li>▪ Calculate the number of moles of sodium hydroxide that reacted with the potassium hydrogen phthalate.</li> <li>▪ Use equation <math>n_{\text{NaOH}} = n_{\text{KH}(\text{C}_8\text{H}_4\text{O}_4)} = 0.00449 \text{ mol}</math>.</li> <li>▪ Calculate the molarity of the sodium hydroxide solution.</li> </ul>

## WORKED EXAMPLE (7.2)

The acidity of a particular white wine was determined by titrating 25.0 mL of the wine with  $0.0511 \text{ mol L}^{-1}$  sodium hydroxide solution; 8.70 mL of the sodium hydroxide was required. Calculate the molarity of hydrogen ions in the wine. Assume that the hydrogen ions come entirely from diprotic tartaric acid ( $\text{H}_2\text{C}_4\text{H}_4\text{O}_6$ ) and calculate the concentration of tartaric acid in the wine in grams per 100 mL.



ANSWER	LOGIC
$\text{H}_2\text{C}_4\text{H}_4\text{O}_6(\text{aq}) + 2\text{NaOH}(\text{aq}) \rightarrow 2\text{Na}^+(\text{aq}) + \text{C}_4\text{H}_4\text{O}_6^{2-}(\text{aq}) + 2\text{H}_2\text{O}(\text{l})$	<ul style="list-style-type: none"> <li>Write a balanced chemical equation for the reaction.</li> </ul>
$n_{\text{NaOH}} = C_{\text{NaOH}} \times V_{\text{NaOH}} = 0.0511 \times 0.00870 = 0.000445 \text{ mol}$	<ul style="list-style-type: none"> <li>Calculate the number of moles of sodium hydroxide that reacts with tartaric acid.</li> </ul>
<p>Using the equation and data in the question:</p> $n_{\text{H}^+} = n_{\text{NaOH}} = 0.000445 \text{ mol.}$	<ul style="list-style-type: none"> <li>Calculate the number of moles of hydrogen ions that react with the sodium hydroxide.</li> </ul>
$C_{\text{H}^+} = \frac{n_{\text{H}^+}}{V_{\text{H}_2\text{C}_4\text{H}_4\text{O}_6}} = \frac{0.000445}{0.0250} = 0.0178 \text{ mol L}^{-1}$	<ul style="list-style-type: none"> <li>Calculate the molarity of hydrogen ions in tartaric acid.</li> </ul>
$n_{\text{H}_2\text{C}_4\text{H}_4\text{O}_6} = \frac{1}{2} n_{\text{NaOH}} = 0.000222 \text{ mol}$ $m_{\text{H}_2\text{C}_4\text{H}_4\text{O}_6} = n_{\text{H}_2\text{C}_4\text{H}_4\text{O}_6} \times M_{\text{H}_2\text{C}_4\text{H}_4\text{O}_6} = 0.000222 \times 150.088 = 0.0334 \text{ g}$ $[\text{H}_2\text{C}_4\text{H}_4\text{O}_6] = \frac{m_{\text{H}_2\text{C}_4\text{H}_4\text{O}_6}}{V_{\text{H}_2\text{C}_4\text{H}_4\text{O}_6}} = \frac{0.00334}{0.0250} = 1.33 \text{ g L}^{-1} = 0.133 \text{ g/100 mL}$ $C_{\text{H}_2\text{C}_4\text{H}_4\text{O}_6} = 0.133 \text{ g/100 mL}$	<ul style="list-style-type: none"> <li>Tartaric acid is diprotic; that is, each molecule of tartaric acid contains two hydrogen ions. Calculate the concentration of tartaric acid in g/100 mL, using the equation.</li> </ul>

### TRY THESE YOURSELF

- Oxalic acid dihydrate ( $(\text{COOH})_2 \cdot 2\text{H}_2\text{O}$ ) can be used as a primary standard for standardising alkali solutions. 0.291 g diprotic oxalic acid required 18.2 mL of a potassium hydroxide solution for exact neutralisation. Calculate the molarity of the hydroxide solution.
- 5.267 g anhydrous sodium carbonate was dissolved in water in a volumetric flask and the volume made up to 250 mL. 10 mL of this solution was pipetted into a conical flask and titrated with hydrochloric acid. 21.3 mL was needed to reach the equivalence point. Calculate the molarity of the hydrochloric acid solution. This solution was then used to determine the concentration of an unknown barium hydroxide solution. 25 mL of the barium hydroxide solution required 27.1 mL hydrochloric acid solution for exact neutralisation. Calculate the molarity of the barium hydroxide solution. In addition, calculate its concentration in grams per litre.

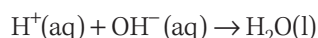
## Choice of indicators

It is important that the indicator chosen is appropriate for the pH of the equivalence point. As you learnt in chapter 6, different acids and bases have different strengths – they have different degrees of ionisation. Hydrochloric acid, sulfuric acid and nitric acid are classified as strong acids because almost all the molecules completely ionise in solution. Other acids are classified as weak acids because only some molecules ionise in solution. Similarly, hydroxide salts and oxide salts are classified as strong bases, while most other bases, including carbonates, are classified as weak bases.

As you learnt in chapter 5, a reaction between an acid and a base (a neutralisation reaction) is essentially a reaction between the hydronium ions and hydroxide ions to form water:



or



However, during neutralisation reactions, a salt is also formed. As you learnt in chapter 6, not all salts are neutral. Depending on the reaction, salts may be acidic, neutral or basic. Table 6.8 on page 183 summarises reactions between strong and weak acids and bases and the pH of the resulting salt.

When determining which indicator to use, you must:

- ▶ identify the salt that is formed
- ▶ determine whether either ion in the salt is a weak acid or a weak base or neither
- ▶ decide whether the resultant solution will have a pH greater than 7, less than 7, or equal to 7.

In light of this, it is important to choose the most appropriate indicator, the one that will change colour at the expected pH of the equivalence point. Table 7.2 lists some common indicators and the types of titrations over which they change colour.

**TABLE 7.2** Indicators used for different types of titrations

TYPE OF TITRATION	EXAMPLE	PREDICTED EQUIVALENCE POINT	INDICATOR
Strong acid–strong base	Hydrochloric acid and sodium hydroxide	Neutral	Bromothymol blue
Strong acid–weak base	Hydrochloric acid and sodium carbonate	Acidic region	Methyl orange
Weak acid–strong base	Acetic acid and sodium hydroxide	Basic region	Phenolphthalein
Weak acid–weak base	Acetic acid and sodium carbonate	Generally do not use direct titration	

## Performing the titration

It is now time to put all of this information together and perform a titration, such as in Investigation 7.3.



How do acid–base titrations work?



Information and communication technology capability



**Titrator – detecting the end point**

Descriptions, photos and short videos related to performing a titration, especially detecting the end point

# INVESTIGATION 7.3

## Performing a titration

### INTRODUCTION

In this titration, you will be using the primary standard solution that you made in Investigation 7.2 to determine the unknown concentration of a solution of hydrochloric acid. Hydrochloric acid is a strong acid and sodium carbonate is a weak base so the equivalence point will be in the acidic region. Methyl orange is a suitable indicator for this titration.

### AIM

To determine the concentration of a hydrochloric acid solution using volumetric analysis.

### MATERIALS

- 250 mL of accurately known concentration of sodium carbonate (made in Investigation 7.2)
- 200 mL hydrochloric acid of unknown concentration
- 50 mL burette
- Retort stand and burette clamp
- 25 mL pipette and pipette filler
- 2 × 150 mL beakers
- 3 × 250 mL conical flasks
- Dropper bottle containing methyl orange indicator
- 2 small labels (for the 150 mL beakers)
- Wash bottle with distilled water
- Filter funnel
- Safety glasses

WHAT ARE THE RISKS IN DOING THIS INVESTIGATION?	HOW CAN YOU MANAGE THESE RISKS TO STAY SAFE?
Dilute solutions of hydrochloric acid, sodium carbonate and methyl orange indicator may splash onto your skin or into your eyes.	Wear safety glasses to avoid any splashes and wash your hands at the end of the investigation.
Glassware could break and cut your hands.	Keep glassware away from edge of the bench. When pipette is not in use, leave pipette filler on pipette to prevent it rolling off the bench. If glassware does break, inform your teacher immediately.

What other risks are associated with your investigation? How can you manage these?

### METHOD

- Rinse one of the 150 mL beakers with a small amount of the hydrochloric acid solution, empty it, label it and fill with about 100 mL of the hydrochloric acid solution.
- Prepare the burette, then fill it with the hydrochloric acid solution.
- Rinse the other 150 mL beaker with a small amount of the sodium carbonate solution, empty it, label it and fill with about 100 mL of the sodium carbonate solution.
- Rinse the conical flask with water.
- Prepare the pipette, then use the pipette to transfer 25.00 mL of the sodium carbonate solution to the conical flask.
- Add two drops of methyl orange indicator to the conical flask and swirl to mix.
- Place the conical flask under the burette and begin the titration.
- When the first permanent colour change has occurred, record all results.
- Repeat the titration several more times until the titrant added is within 0.03 mL.



Flow diagrams





## » RESULTS

Draw up a suitably formatted table and record the:

- concentration of sodium carbonate solution
- volume of sodium carbonate used
- volume of hydrochloric acid used.

## ANALYSIS OF RESULTS

- 1 Calculate the average volume of hydrochloric acid used.
- 2 Write a balanced chemical equation for the reaction between hydrochloric acid and sodium carbonate.
- 3 Calculate the number of moles of sodium carbonate placed in the reaction vessel (conical flask).
- 4 Use the mole ratio from your balanced chemical equation to determine the number of moles of hydrochloric acid that was titrated.
- 5 Calculate the concentration of hydrochloric acid that was titrated.

## DISCUSSION

- 1 Compare your value for the concentration of the hydrochloric acid with your peers and with the value provided by your teacher.
- 2 Discuss any variations in the value and suggest how to improve the accuracy of your results.
- 3 Justify why the conical flask was rinsed with water and not the solutions that were placed in it.

## CONCLUSION

With reference to the data obtained and its analysis, write a conclusion based on the aim of this investigation.

Investigation 7.3 is the simplest type of titration – where an acid and a base are titrated directly against each other using an appropriate acid–base indicator. The only issues to be considered are:

- identifying the correct indicator to use; and
- making sure that the chemical equation is correctly balanced to ensure that the correct mole ratio is used in the calculations.

- The solution in the burette is called the titrant and the solution to be analysed is called the analyte.
- It is important that the indicator chosen is appropriate for the pH of the equivalence point.

## CHECK YOUR UNDERSTANDING

7.3

- 1 Identify the term given to a solution that is placed into a burette.
- 2 Justify whether an analyte can be a titrant.
- 3 Explain why titrations are repeated and the volumes are averaged.
- 4 25.00 mL of  $0.0873 \text{ mol L}^{-1}$  HCl was titrated with 37.30 mL of sodium hydroxide.
  - a Identify the most appropriate indicator to be used for this titration.
  - b Calculate the concentration of the sodium hydroxide solution.



- 5 20.00 mL of sulfuric acid was titrated with  $0.145 \text{ mol L}^{-1}$  of sodium hydrogen carbonate. The titration was performed four times. The volumes of sodium hydrogen carbonate were 22.35 mL, 22.40 mL, 24.35 mL and 22.35 mL.
- Identify an appropriate indicator to be used in this titration.
  - Justify which solution is in the burette.
  - Explain how you will be able to determine when equivalence has been reached.
  - Write a balanced equation for this reaction.
  - Calculate the concentration of the sulfuric acid solution.

## 7.4 Other types of titrations

Once the direct titration technique is understood, variations on this can be used for more complex examples. Some other applications of titrations include:

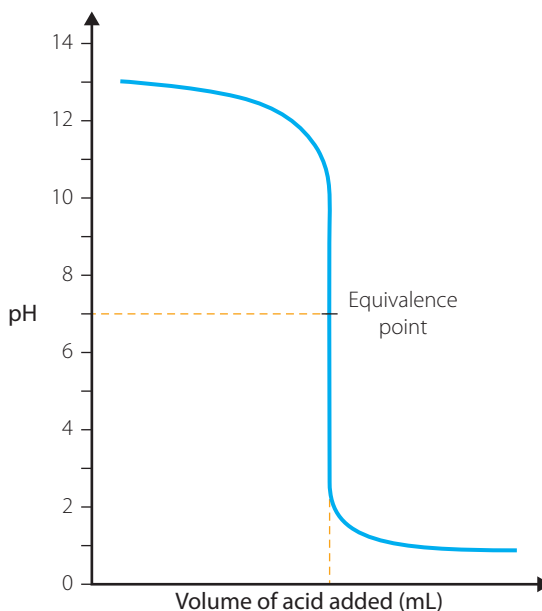
- using pH curves to determine the end point
- using conductivity graphs to determine the end point
- using back titrations to determine the concentration or mass of a substance that is not able to be determined directly
- performing a redox titration.

### Using titration curves

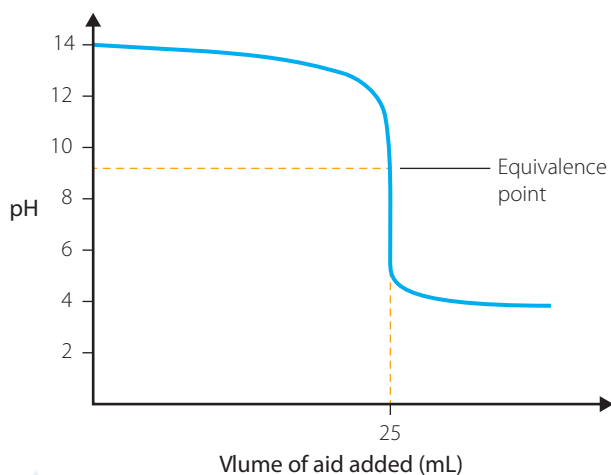
If the solution being analysed is not clear, then it will interfere with the colour change of the indicator. Some solutions, such as malt vinegar, orange juice and red wine are so dark that the indicator colour cannot be seen at all. In this case, a pH meter would be used rather than an indicator. The data from the pH is recorded then graphed. The resulting graph is then used to determine the volume of solution added at equivalence point.

When performing an acid–base titration, the pH of the solution in the reaction vessel changes. If the base is pipetted into the conical flask, then the acid is added from the burette, the pH will change from basic to acidic. The shape of the graph depends on the strength of the acid and base used; however, it is not a linear change.

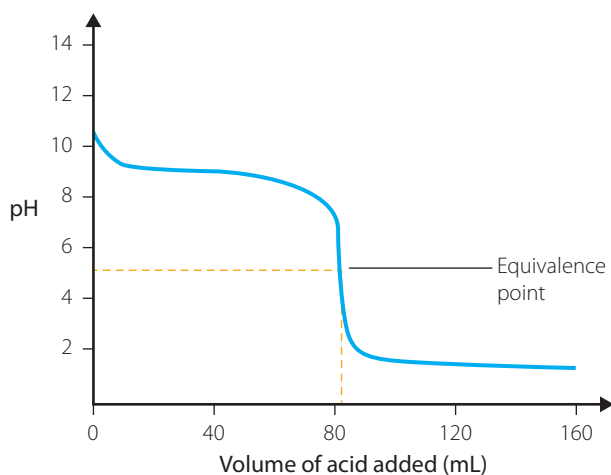
The graph for a titration of a strong base and strong acid (Figure 7.7) shows that the pH starts at a very high value, in the basic region. It remains fairly constant until close to the equivalence point, when it suddenly decreases. The pH drops from 12–13 to 1–2. When acid is in excess, the pH stays reasonably constant again at a very low pH. The equivalence point is the midpoint of the sudden change in the pH.



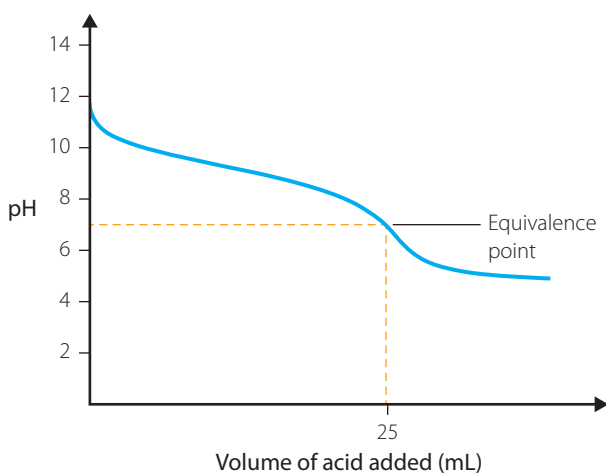
**FIGURE 7.7** A pH graph for a titration involving a strong base and a strong acid



**FIGURE 7.8** A pH graph for a titration involving a strong base and a weak acid



**FIGURE 7.9** A pH graph for a titration involving a weak base and a strong acid



**FIGURE 7.10** A pH graph for a titration involving a weak base and a weak acid

The graph for a titration of a strong base and weak acid (Figure 7.8) again shows that the pH starts at a very high value, in the basic region. It remains fairly constant until close to the equivalence point, when it suddenly decreases, although not as much as for the strong base–strong acid titration. The pH drops from 12–13 to about 4. When acid is in excess, the slope of the pH graph changes and eventually stays reasonably constant at a low pH. The equivalence point is the midpoint of the sudden change in the pH. This is because the salt produced in this reaction is basic so the pH of the solution at equivalence point is greater than 7.

The graph for the titration of a weak base and strong acid (Figure 7.9) shows that the pH starts at a high value in the basic region, although not as high as for the strong base. It decreases slightly, and then close to the equivalence point, suddenly decreases, although not as much as for the strong base–strong acid titration. The pH drops from 8–9 to 1–2. When acid is in excess, the pH stays reasonably constant again at a very low pH. The equivalence point is the midpoint of the sudden change in the pH. This is because the salt produced in this reaction is acidic so the pH of the solution at equivalence point is less than 7.

The graph for the titration of a weak base and weak acid (Figure 7.10) shows that pH starts at a high value in the basic region, although not as high as for the strong base. It remains fairly constant until close to the equivalence point, when it decreases. This change is much smaller than for the other curves. The pH drops from 8–9 to 4–5. When weak acid is in excess, the pH decreases reasonably constantly at a low pH. Generally, titrations of weak acids and weak bases are not performed directly since the curve does not show a significant change in pH at the equivalence point. It is very difficult to identify the equivalence point.

In large analytical laboratories, these titrations can be done using automated systems. In the school laboratory, it is a little more time-consuming. The basic technique is to record the pH in the reaction vessel at the beginning, then again after each millilitre of titrant is added. The data should be analysed so that the location of the large change in pH is identified. The method should be repeated, with pH measurements recorded every 0.2 (or even 0.1) mL close to the equivalence point, so that you plot the shape of the graph accurately.

## INVESTIGATION 7.4

### Acid content in orange juice

#### INTRODUCTION

The colour of orange juice distorts the colour change of indicators and makes it difficult to determine the end point, so using a pH meter is a more suitable method. It is assumed that all of the acid in the orange juice that reacts in the titration with sodium hydroxide is citric acid ( $C_6H_8O_7$ ). You may need to use a beaker as the reaction vessel since the pH meter may not fit into a conical flask.

#### AIM

Write an aim for this investigation.

#### MATERIALS

- About 20 mL of orange juice (not orange fruit juice drink)
- 200 mL standardised sodium hydroxide solution (about  $0.1 \text{ mol L}^{-1}$ )
- Calibrated pH meter
- 50 mL burette
- Retort stand and burette clamp
- 150 mL beaker
- 3 × 250 mL conical flasks or beakers
- 1 small label (for the 150 mL beaker)
- Wash bottle with distilled water
- Electronic balance
- Filter funnel
- Safety glasses

WHAT ARE THE RISKS IN DOING THIS INVESTIGATION?	HOW CAN YOU MANAGE THESE RISKS TO STAY SAFE?
Dilute solutions of sodium hydroxide may splash onto your skin or into your eyes.	Wear safety glasses and wash your hands at the end of the experiment.
Glassware could break and cut you.	Always ensure that glassware is kept away from the edge of benches. If glassware does break, inform your teacher immediately.

What other risks are associated with your investigation? How can you manage these?

#### METHOD

- 1 Rinse the 150 mL beakers with a small amount of the sodium hydroxide solution, empty it, label it and fill it with about 100 mL of the sodium hydroxide solution.
- 2 Prepare the burette, then fill it with the sodium hydroxide solution.
- 3 Rinse the reaction vessel (conical flask or 250 mL beaker) with water.
- 4 Weigh the reaction vessel.
- 5 Pour about 20 mL of orange juice into the reaction vessel and reweigh it.
- 6 Add about 50 mL of water to the reaction vessel so the depth is sufficient to cover the glass electrode of the pH meter.
- 7 Place the pH meter in the reaction vessel and record the pH.
- 8 Place the reaction vessel under the burette and begin the titration, stopping after each millilitre of sodium hydroxide has been added, to record the pH.



- » 9 Continue adding sodium hydroxide until the pH is fairly constant in the basic region.
- 10 Repeat the titration a couple more times with more frequent sampling of pH near the large change in pH.

### RESULTS

For each titration, record the following.

- The concentration of sodium hydroxide solution
- A table showing volume of sodium hydroxide added and pH of solution in reaction vessel
- Mass of orange juice added to reaction vessel

### ANALYSIS OF RESULTS

- 1 Write a balanced chemical equation for the reaction between citric acid and sodium hydroxide. Citric acid is a triprotic carboxylic acid.
- 2 For each data set except the first, use a spreadsheet program such as Microsoft Excel or Apple Numbers to input the data and produce a scatter graph of pH versus volume of sodium hydroxide added.
- 3 Determine the volume of sodium hydroxide added at equivalence.
- 4 Calculate the number of moles of sodium hydroxide that was titrated with the orange juice.
- 5 Use the mole ratio from your balanced chemical equation to determine the number of moles of citric acid that reacted with the sodium hydroxide.
- 6 Calculate the mass of citric acid that reacted with the sodium hydroxide.
- 7 Calculate the percentage of citric acid present in the orange juice.
- 8 Average your values for the percentage of citric acid present in the orange juice.

### DISCUSSION

- 1 Compare your value for the percentage of acid in orange juice with those of other students.
- 2 Discuss any variations in the value and make suggestions for improving the accuracy of your results.
- 3 Justify why the first data set was discarded.
- 4 Justify why the averaging of data only occurred in the last step of the analysis.

### CONCLUSION

With reference to the data obtained and its analysis, write a conclusion based on the aim of this investigation.

## Using conductivity graphs

In Investigation 7.4 (page 205), a pH meter was used to trace the change in pH of the analyte during the titration. Equivalence point, and hence, volume of titrant was determined from the titration curve drawn using the experimental data.

Another method of determining when the equivalence point is reached is by measuring the change in conductivity of the analyte using a conductivity probe. A titration that uses changes in conductivity to determine equivalence point is called a **conductometric titration**.

The main advantages of using a conductometric titration are that it can be used:

- with very diluted solutions
- when species being investigated are at trace levels
- with coloured or turbid solutions
- when the system involves relatively incomplete reactions
- for acid–base, redox, precipitation and non-aqueous titrations.



#### Titrator simulation

Link to simulations of acid–base titrations that can be done on screen

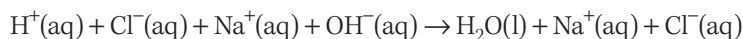
The electrical conductivity of a solution is proportional to the concentration of ions in the solution. The conductivity of a solution of a strong acid or base, which ionise completely, is higher than the conductivity of a solution of a weak acid or base. Similarly, a concentrated solution will have higher conductivity than a dilute solution of the same substance. Other factors that affect conductivity are the size of the ions (as ion size increases conductivity decreases because larger ions are less mobile) and temperature (as temperature increases, conductivity increases because the mobility of the ions has increased).

Changes in conductivity during a conductometric titration are due to the fact that during the titration one of the ions is replaced by another of different conductivity. The equivalence point is determined graphically by plotting change in conductance against volume of titrant added.

Typical conductivity graphs for acid–base conductometric titrations are shown to the right. Just as for titration curves, the shape of the graph depends on the strength of the acid and base used.

The graph for a strong acid and strong base (Figure 7.11) shows that conductance starts at a high value due to the presence of the highly mobile hydrogen ions.

Using HCl and NaOH as examples, when the base is added, the following reaction occurs:



The highly mobile  $\text{H}^+$  ion reacts with the  $\text{OH}^-$  to form the weakly ionised water molecule. The conductivity of the solution decreases as the  $\text{H}^+$  ion is replaced by the less mobile  $\text{Na}^+$  ion until equivalence point where only  $\text{Na}^+(\text{aq})$  and  $\text{Cl}^-(\text{aq})$  ions are present. Continued addition of NaOH leads to an increase in conductivity due to the increasing concentration of  $\text{Na}^+(\text{aq})$  and  $\text{OH}^-(\text{aq})$  ions. The equivalence point is the minimum of the curve.

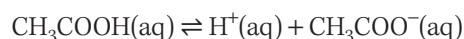
The graph for a strong acid and weak base (Figure 7.12) shows that conductance starts at a high value due to the presence of the highly mobile hydrogen ions.

When the weak base is added, the highly mobile  $\text{H}^+$  ion reacts with the  $\text{OH}^-$  to form the weakly ionised water molecule. The conductivity of the solution decreases as the  $\text{H}^+$  ion is replaced until the equivalence point. Unlike the strong base situation, continued addition of the weak base does not lead to an increase in conductivity. The graph becomes almost horizontal because the weak base is not appreciably ionised. The equivalence point is the minimum of the curve.

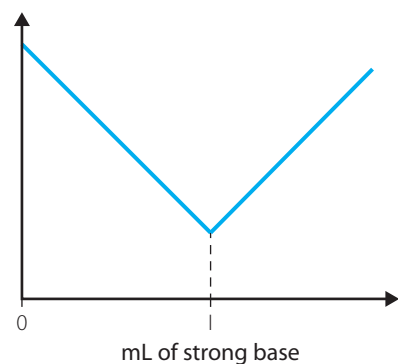
The graph for a weak acid and strong base (Figure 7.13) shows that before titration, conductance starts at a low value. This is due to the small degree of ionisation that occurs in a weak acid, resulting in a low concentration of hydrogen ions.

When the strong base is added, the  $\text{H}^+$  ion reacts with the  $\text{OH}^-$  to form the weakly ionised water molecule, resulting in a slight decrease in conductivity. This slight decrease is also due to the presence of the weak acid anion that suppresses the ionisation of the weak acid. This is called the common ion effect and you will learn more about this later in this chapter when you study the action of buffers.

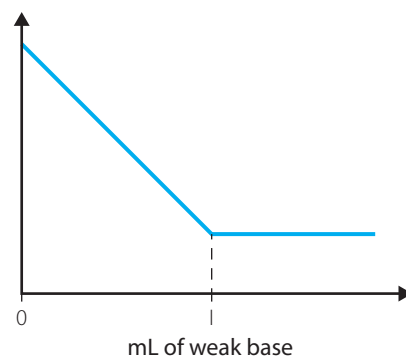
For example:



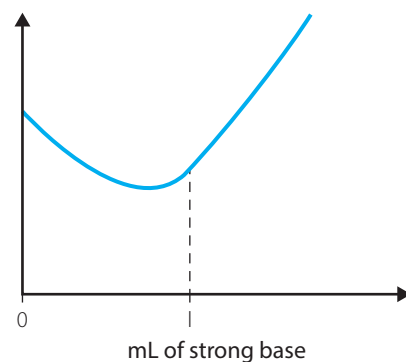
According to Le Chatelier, increasing concentration of the  $\text{CH}_3\text{COO}^-(\text{aq})$  will drive the reaction in the reverse direction, preventing ionisation.



**FIGURE 7.11** Conductivity graph for a titration involving a strong acid and a strong base

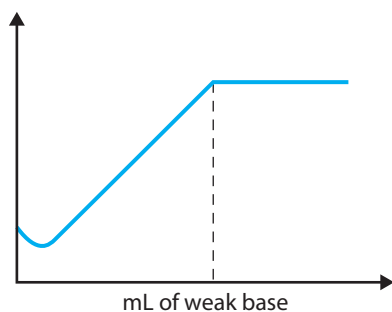


**FIGURE 7.12** Conductivity graph for a titration involving a strong acid and a weak base



**FIGURE 7.13** Conductivity graph for a titration involving a weak acid and a strong base





**FIGURE 7.14** Conductivity graph for a titration involving a weak acid and a weak base

However, with further addition of the strong base the conductivity increases as the strong base reacts with the unionised weak acid molecules and produces a salt which is basic. Near equivalence point, the graph is curved due to the hydrolysis of the salt produced. Continued addition of the strong base leads to a rapid increase in conductivity.

The graph for a weak acid and weak base (Figure 7.14) shows that before titration, conductance starts at a low value. This is due to the small degree of ionisation that occurs in a weak acid, resulting in a low concentration of hydrogen ions. The initial shape of the graph is similar to that obtained when titrating a weak acid and strong base. However, after the equivalence point there is little change in conductivity due to the small degree of dissociation of a weak base.

## Back titrations

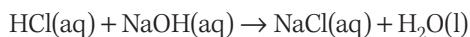
Sometimes, it is not appropriate to directly titrate one substance against another. In this instance, the indirect method of **back titration** is used. Back titration is when:

- it is difficult to determine a definite end point because the reaction occurs too slowly
- the sample is not soluble in water but will react with an acid, for example
- the sample is toxic
- the sample is volatile
- the sample is gaseous and in a mixture of gases
- the sample is fairly unreactive (that is, too weak to have a clearly defined end point, the sample is present in low concentration or in trace amounts in a mixture).

A back titration would be used to determine the percentage of calcium carbonate in a sample of limestone. Calcium carbonate is not soluble in water, so the sample cannot be dissolved to form a solution. However, the following reaction will occur with hydrochloric acid:



A known excess volume of a standardised hydrochloric acid solution would be added to the limestone. It is assumed that the acid only reacts with the calcium carbonate, not with any of the other impurities. The reaction would be left for a period of time and then the reaction vessel would be heated to ensure that the reaction goes to completion and all of the carbon dioxide has been released. A couple of drops of methyl orange indicator are added to the solution, and then it is titrated against a standardised sodium hydroxide solution. The excess hydrochloric acid reacts with the sodium hydroxide until the end point is reached. The equation for this reaction is:



Back titrations are also used for the analysis of the:

- nitrogen content of lawn fertilisers, usually present as ammonium salts
- aspirin (acetylsalicylic acid) content in a commercial painkiller tablet (such as Disprin or Aspro Clear)
- amount of alcohol in wine.



### Conductometric titration example

Conductometric titration showing method and analysis of results



Dominoes

## WORKED EXAMPLE 7.3

- 1 A 2.5 g sample of limestone was dissolved in 75.0 mL of 0.996 mol L<sup>-1</sup> hydrochloric acid. After heating to ensure that all of the CO<sub>2</sub> was expelled, the solution was cooled and diluted to 250 mL. A 25.0 mL sample of this diluted solution was titrated with 25.27 mL of a standardised solution of 0.1215 mol L<sup>-1</sup> sodium hydroxide. Determine the percentage of calcium carbonate in the original limestone sample.
- 2 A student wanted to determine the percentage of the ammonium ion, NH<sub>4</sub><sup>+</sup>(aq), present in a particular brand of plant food. The student added 50.0 mL of 0.890 mol L<sup>-1</sup> sodium hydroxide to a 5 g sample of the plant food. This was boiled to promote the formation of ammonia. The excess sodium hydroxide was titrated against 42.3 mL of 0.881 mol L<sup>-1</sup> hydrochloric acid. Calculate the percentage of ammonium ion present in the plant food.

ANSWER	LOGIC
<p>1 <math>2\text{HCl}(\text{aq}) + \text{CaCO}_3(\text{s}) \rightarrow \text{CaCl}_2(\text{aq}) + \text{CO}_2(\text{g}) + \text{H}_2\text{O}(\text{l})</math></p> <p>2 <math>\text{HCl}(\text{aq}) + \text{NaOH}(\text{aq}) \rightarrow \text{NaCl}(\text{aq}) + \text{H}_2\text{O}(\text{l})</math></p>	<ul style="list-style-type: none"> <li>Write balanced chemical equations for all reactions.</li> </ul>
$n_{\text{HCl}} = C_{\text{HCl}} \times V_{\text{HCl}} = 0.996 \times 0.075 = 0.0747 \text{ mol}$	<ul style="list-style-type: none"> <li>Calculate the original number of moles of HCl that was added to the limestone.</li> </ul>
$n_{\text{NaOH}} = C_{\text{NaOH}} \times V_{\text{NaOH}} = 0.1215 \times 0.02527 = 0.00307 \text{ mol}$ $n_{\text{HCl}} = n_{\text{NaOH}} = 0.00307 \text{ mol}$ <p>This is the number of moles of unreacted HCl in the 25.0 mL sample of the diluted solution.</p> <p>Since the solution was 250 mL, the number of moles of HCl present in this solution is 10 times the value calculated above.</p> $n_{\text{HCl}} \text{ in 250 mL solution} = 10 \times 0.00307 = 0.0307 \text{ mol}$	<ul style="list-style-type: none"> <li>Calculate the number of moles of HCl that reacted with the NaOH.</li> </ul>
<p>number moles HCl reacted with CaCO<sub>3</sub> = number moles HCl added to limestone – number moles HCl reacted with NaOH</p> $n_{\text{HCl}} \text{ reacted with CaCO}_3 = 0.0747 - 0.0307 = 0.0440 \text{ mol}$	<ul style="list-style-type: none"> <li>Calculate the number of moles of HCl that reacted with the CaCO<sub>3</sub>.</li> </ul>
$n_{\text{CaCO}_3} = \frac{1}{2} n_{\text{HCl}} = \frac{1}{2} \times 0.0440 = 0.0220 \text{ mol}$	<ul style="list-style-type: none"> <li>Calculate the number of moles of CaCO<sub>3</sub> that reacted with HCl; this is the number of moles of CaCO<sub>3</sub> in the limestone sample.</li> </ul>
$m_{\text{CaCO}_3} = n_{\text{CaCO}_3} \times M_{\text{CaCO}_3} = 0.0220 \times 100.09 = 2.20 \text{ g}$ $\% \text{CaCO}_3 = \frac{m_{\text{CaCO}_3}}{m_{\text{limestone}}} \times 100 = \frac{2.20}{2.50} \times 100 = 88\%$	<ul style="list-style-type: none"> <li>Calculate the percentage of CaCO<sub>3</sub> in original limestone sample.</li> </ul>
$\text{NH}_4^+(\text{aq}) + \text{OH}^-(\text{aq}) \rightarrow \text{NH}_3(\text{g}) + \text{H}_2\text{O}(\text{l})$ $\text{HCl}(\text{aq}) + \text{NaOH}(\text{aq}) \rightarrow \text{NaCl}(\text{aq}) + \text{H}_2\text{O}(\text{l})$	<ul style="list-style-type: none"> <li>Write balanced chemical equations for all reactions.</li> </ul>
$n_{\text{NaOH}} = C_{\text{NaOH}} \times V_{\text{NaOH}} = 0.890 \times 0.0500 = 0.0445 \text{ mol}$	<ul style="list-style-type: none"> <li>Calculate the original number of moles of NaOH that was added to the plant food.</li> </ul>
$n_{\text{HCl}} = C_{\text{HCl}} \times V_{\text{HCl}} = 0.881 \times 0.0423 = 0.0373 \text{ mol}$ $n_{\text{NaOH}} = n_{\text{HCl}} = 0.0373 \text{ mol}$	<ul style="list-style-type: none"> <li>Calculate the number of moles of NaOH that reacted with HCl.</li> </ul>

ANSWER	LOGIC
number of moles of NaOH reacted with $\text{NH}_4^+$ = number of moles of NaOH added to plant food – number of moles NaOH reacted with HCl $n_{\text{NaOH}}$ reacted with ammonium = $0.0445 - 0.0373 = 0.00720$ mol	<ul style="list-style-type: none"> <li>Calculate the number of moles of NaOH that reacted with the <math>\text{NH}_4^+</math>.</li> </ul>
From the equation: $n_{\text{NH}_4^+} = n_{\text{NaOH}} = 0.00720$ mol	<ul style="list-style-type: none"> <li>Calculate the number of moles of <math>\text{NH}_4^+</math> that reacted with NaOH; this is the number of moles of <math>\text{NH}_4^+</math> present in the sample of plant food.</li> </ul>
$m_{\text{NH}_4^+} = n_{\text{NH}_4^+} \times M_{\text{NH}_4^+} = 0.00720 \times 18.042 = 0.130$ g $\% \text{NH}_4^+ = \frac{m_{\text{NH}_4^+}}{m_{\text{plant food}}} \times 100 = \frac{0.130}{5.00} \times 100 = 2.6\%$	<ul style="list-style-type: none"> <li>Calculate the percentage of <math>\text{NH}_4^+</math> present in the plant food.</li> </ul>
<b>1</b> Percentage of calcium carbonate = 88% <b>2</b> Percentage of ammonium ion = 2.6%	

#### TRY THESE YOURSELF

- To calculate the percentage of calcium carbonate in a sample of limestone, a chemist dissolved 0.552 g in 50 mL of  $0.121 \text{ mol L}^{-1}$  hydrochloric acid, boiled the mixture gently to ensure complete reaction (and to expel all carbon dioxide), and then titrated the excess hydrochloric acid with 21.1 mL of  $0.0950 \text{ mol L}^{-1}$  sodium hydroxide solution. Calculate the mass of calcium carbonate in the sample and, hence, the percentage.
- To determine the amount of ammonium ion in a sample, a chemist dissolved 0.375 g of the sample in water, added 25 mL of  $0.414 \text{ mol L}^{-1}$  sodium hydroxide solution and boiled the mixture to drive off all of the ammonia formed. The hydroxide left over, after all of the ammonium ion had been reacted, required 21.2 mL of  $0.161 \text{ mol L}^{-1}$  hydrochloric acid for exact neutralisation. Calculate the mass of ammonium ion in the original sample and, hence, the weight percentage of ammonium ion in the sample.

## INVESTIGATION 7.5

### Analysis of aspirin using back titration

#### INTRODUCTION

The following procedure outlines a back titration process for analysing an aspirin product to determine the amount of acetylsalicylic acid in the product (Figure 7.15).

A back titration is used in preference to a direct titration in this instance because a clear end point is obtained. The back titration involves a reaction between the strong acid (hydrochloric acid) and the strong base (sodium hydroxide) thus producing an easily recognisable end point. On the other hand, the direct titration would involve a reaction between the weak acetylsalicylic acid and the strong sodium hydroxide base that does not have as clearly a recognisable end point.

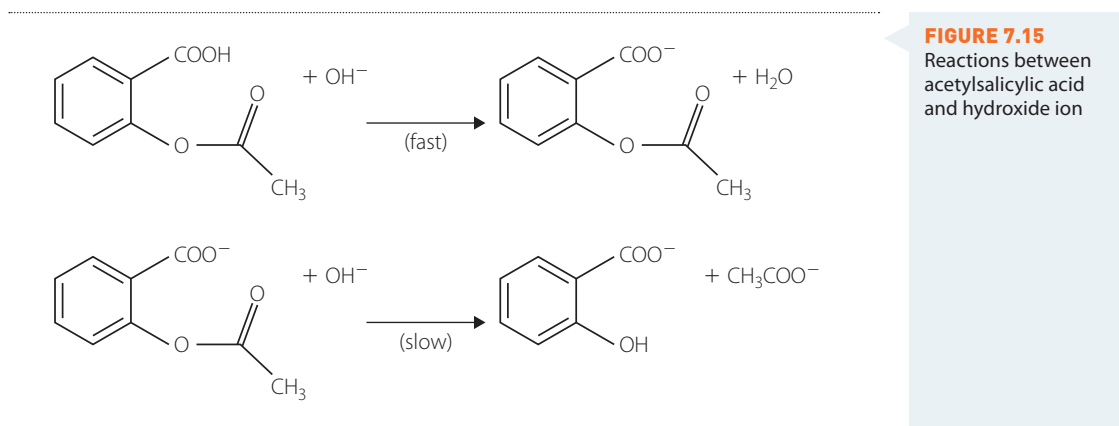
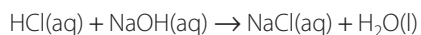
Initially, a known number of moles of sodium hydroxide is added to the prepared aspirin sample. A neutralisation reaction occurs between the sodium hydroxide and the acetylsalicylic acid present in the sample. The product is further hydrolysed. The unreacted (excess) sodium hydroxide is then titrated against a standardised solution of hydrochloric acid.



» The difference between the number of moles of NaOH that was originally added and the number of moles that remain to neutralise the HCl is determined. This is equal to the number of moles of NaOH that reacted with the acetylsalicylic acid. Hence, the number of moles of acetylsalicylic acid in the aspirin sample can be determined.

The balanced equations for the reactions that occur when excess NaOH is added to aspirin and the reaction is allowed to proceed to completion are given below. This process is shown in Figure 7.15.

The reaction that occurs in the titration is between HCl and the remaining unreacted NaOH:



For a blank titration, aspirin is initially dissolved in ethanol, since it is more readily soluble in ethanol than water. There may be a reaction between the solvent, ethanol, and the NaOH. Therefore, the amount of sodium hydroxide used in this reaction must be taken into account. This is done by titrating the ethanol–sodium hydroxide mixture with hydrochloric acid. This is called a blank titration.

#### AIM

To determine the concentration of acetylsalicylic acid in an aspirin sample.

#### MATERIALS

- Aspirin sample
- 50 mL ethanol (96%)
- 200 mL of  $0.5 \text{ mol L}^{-1}$  NaOH
- 200 mL of  $0.5 \text{ mol L}^{-1}$  HCl
- Distilled water
- Phenolphthalein indicator
- Burette
- Retort stand and burette clamp
- 5 mL pipette
- 25 mL pipette
- Pipette filler
- 6 × 250 mL conical flask and stoppers
- Mortar and pestle
- Electronic balance
- Spatula
- Filter funnel
- Paper towel
- White tile
- Safety glasses





WHAT ARE THE RISKS IN DOING THIS INVESTIGATION?	HOW CAN YOU MANAGE THESE RISKS TO STAY SAFE?
Ethanol is highly flammable.	Use in a well-ventilated area. Keep away from naked flames.
Dilute solutions of sodium hydroxide may splash onto your skin or into your eyes.	Wear safety glasses and wash your hands at the end of the investigation.
Glassware could break and cut your hands.	Keep glassware away from the edge of the bench. When the pipette is not in use, leave the pipette filler on the pipette to prevent it rolling off the bench. If glassware does break, inform your teacher immediately.

What other risks are associated with your investigation? How can you manage these?

#### METHOD

##### PART A: BLANK TITRATION

- Pipette 5 mL ethanol into a 250 mL conical flask.
- Pipette 25 mL sodium hydroxide into the same flask. Add 1–2 drops of phenolphthalein indicator and swirl to mix.
- Fill burette with 0.5 mol L<sup>-1</sup> HCl. Record volume reading.
- Titrate the solution in the flask with 0.5 mol L<sup>-1</sup> HCl until the indicator colour just disappears. Record the final volume reading from the burette.
- Repeat steps 1–4 until three consistent results are achieved.

##### PART B: BACK TITRATION

- Crush the aspirin sample to a fine powder using mortar and pestle.
- Weigh accurately 0.5 g of crushed aspirin sample in 250 mL conical flask.
- Pipette 5 mL ethanol into the 250 mL flask containing aspirin sample.
- Pipette 25 mL of 0.5 mol L<sup>-1</sup> NaOH into the same flask. Swirl to dissolve the sample.
- Seal flask with stopper and allow to stand for 1 hour.
- Add 1–2 drops of indicator and swirl to mix.
- Fill burette with 0.5 mol L<sup>-1</sup> HCl. Record volume reading.
- Titrate the solution in the flask with the acid until the purple indicator colour just disappears. Record the final volume reading from the burette.
- Repeat steps 2–8 until three consistent results are achieved.

#### RESULTS

Copy and complete the tables below.

##### PART A: BLANK TITRATION

	TRIAL 1	TRIAL 2	TRIAL 3	AVERAGE
Volume ethanol added				
Initial burette reading				
Final burette reading				
Volume HCl				
Volume NaOH added				



## » PART B: BACK TITRATION

	TRIAL 1	TRIAL 2	TRIAL 3	TRIAL 4
Volume NaOH added				
Mass sample				
Initial burette reading				
Final burette reading				
Volume HCl				

### ANALYSIS OF RESULTS

#### PART A: BLANK TITRATION

- 1 Calculate the number of moles of HCl used.
- 2 Calculate the initial number of moles of NaOH.
- 3 Calculate the number of moles of NaOH which reacted with HCl. This represents the number of moles of NaOH available for subsequent reactions. The difference is the number of moles of NaOH that reacted with the ethanol.

#### PART B: BACK TITRATION

- 1 Calculate the number of moles of hydrochloric acid.
- 2 Calculate the number of moles of sodium hydroxide that reacted with hydrochloric acid. This is referred to as the *excess* sodium hydroxide (remaining after reaction with aspirin and ethanol).
- 3 Calculate the number of moles of sodium hydroxide that reacted with the aspirin by subtracting the number of moles of excess sodium hydroxide from the number of moles of sodium hydroxide available for reaction. The number of moles of sodium hydroxide available for reaction was determined in part A (3).
- 4 Write a balanced chemical equation for the complete reaction between acetylsalicylic acid and sodium hydroxide.
- 5 From the balanced chemical equation, state the mole ratio of the acetylsalicylic acid and sodium hydroxide.
- 6 Calculate the number of moles of acetylsalicylic acid in the tablet.
- 7 Determine the molar mass of acetylsalicylic acid.
- 8 Calculate the mass of acetylsalicylic acid using the molar mass and the number of moles of acetylsalicylic acid.
- 9 Calculate the percentage of acetylsalicylic acid in the aspirin tablet.

### DISCUSSION

Compare the calculated percentage of acetylsalicylic acid to that stated on the package. Explain possible reasons for the discrepancies.

### CONCLUSION

With reference to the data obtained, write a conclusion relating the stated amount of aspirin in the product to the results.



## Redox titrations

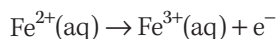
Volumetric analysis can also be used to analyse redox reactions. As with all titrations, you must determine the equivalence point. When using salts of transition metals such as manganese, the natural colour of their varying oxidation states can be used to determine the end point. In other cases, appropriate indicators must be used.



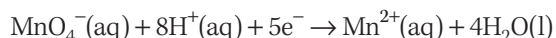
Redox titration

In Investigation 7.6, you will use a redox titration to standardise a potassium permanganate solution. Analytical grade (AR grade) hydrated iron(II) ammonium sulfate,  $\text{Fe}(\text{NH}_4)_2(\text{SO}_4)_2 \cdot 6\text{H}_2\text{O}$ , is a commonly used primary standard for redox titrations. Although it is hydrated, it has a large molar mass and a high purity, can be directly weighed, does not react with the atmosphere and remains stable for a long time.

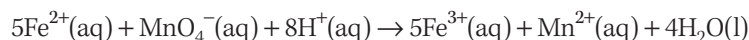
The oxidation reaction is:



The reduction reaction is:



Therefore, the reaction for the titration is:



## INVESTIGATION 7.6

### Teacher demonstration: Standardising potassium permanganate

#### INTRODUCTION

A pale green solution of hydrated iron(II) ammonium sulfate will be used to determine the concentration of a potassium permanganate solution. The manganese(VII) in  $\text{MnO}_4^{-}$  is a purple colour, while the manganese(II) is a pale pink colour. The end point is reached when the first permanent pink-purple colour is seen. This indicates a very slight excess of  $\text{MnO}_4^{-}$ . However, this one drop of excess  $\text{MnO}_4^{-}$  is negligible in the measured volume.

#### AIM

To standardise a potassium permanganate solution.

#### MATERIALS

- 10 g of hydrated iron ammonium sulfate ( $\text{Fe}(\text{NH}_4)_2(\text{SO}_4)_2 \cdot 6\text{H}_2\text{O}$ )
- 5 mL of concentrated sulfuric acid
- 50 mL of  $2 \text{ mol L}^{-1}$  sulfuric acid
- 200 mL of unknown concentration of potassium permanganate
- 50 mL burette
- 150 mL beaker
- 2 × 100 mL beakers
- 25 mL pipette and pipette filler
- 10 mL measuring cylinder
- 25 mL measuring cylinder
- 250 mL conical flask
- 250 mL volumetric flask and lid



- » Filter funnel
- Retort stand and burette clamp
- Electronic balance
- Spatula
- Stirring rod
- 2 small labels to label the 150 mL beakers
- Wash bottle with distilled water
- Safety glasses

WHAT ARE THE RISKS IN DOING THIS INVESTIGATION?	HOW CAN YOU MANAGE THESE RISKS TO STAY SAFE?
Chemicals may splash onto skin or into eyes.	Wear safety glasses and wash hands at the end of the experiment.
Glassware could break and cut hands.	Keep glassware away from the edge of the bench. When the pipette is not in use, leave the pipette filler on the pipette to prevent it rolling off the bench. If glassware does break, inform your teacher immediately.
Concentrated sulfuric acid is corrosive and emits harmful vapours.	Teacher to dispense acid. Kept in the fume cupboard when not in use. PPE to be worn when handling the acid.



What other risks are associated with this investigation? How can these be managed?

#### METHOD

- 1 Rinse the volumetric flask with a small volume of distilled water.
- 2 Place a clean, dry 150 mL beaker on the electronic balance and tare the balance.
- 3 Accurately measure out, to the nearest 0.001 g, about 10 g of hydrated iron(II) ammonium sulfate into the beaker.
- 4 Add about 80 mL of distilled water to the beaker and stir until the hydrated iron(II) ammonium sulfate has completely dissolved.
- 5 Place the filter funnel into the neck of the volumetric flask.
- 6 Pour the iron(II) solution into the volumetric flask.
- 7 Pour a small volume of distilled water into the beaker, swirl and pour it into the volumetric flask.
- 8 Add about 5 mL of concentrated sulfuric acid to the volumetric flask.
- 9 Rinse the filter funnel by pouring some distilled water from the wash bottle into the volumetric flask.
- 10 Remove the filter funnel.
- 11 Fill the volumetric flask with distilled water until the bottom of the meniscus is just touching the line on the volumetric flask.
- 12 Place the lid on the volumetric flask, hold the lid in place, invert, and swirl the contents of the flask so that mixing occurs.
- 13 Rinse one of the 100 mL beakers with a small amount of the potassium permanganate solution, empty it, label it and fill it with about 100 mL of the potassium permanganate solution.
- 14 Prepare the burette, then fill it with the potassium permanganate solution.
- 15 Rinse the other 100 mL beaker with a small amount of the iron(II) solution, empty it, label it and fill it with about 100 mL of the iron(II) solution.
- 16 Rinse the conical flask with water.
- 17 Prepare the pipette, then use the pipette to transfer 25 mL of the iron(II) solution to the conical flask.
- 18 Add about 10 mL of 2 mol L<sup>-1</sup> sulfuric acid solution to the conical flask and swirl to mix.
- 19 Place the conical flask under the burette and begin the titration.
- 20 When the first permanent colour change has occurred, record the result.
- 21 Repeat the titration several more times until the titrant added is within 0.03 mL.



## » RESULTS

Record the:

- concentration of hydrated iron(II) ammonium sulfate solution
- volume of iron(II) solution used
- volume of potassium permanganate solution used.

## ANALYSIS OF RESULTS

- 1 Calculate the average volume of potassium permanganate solution used.
- 2 Calculate the number of moles of iron(II) solution placed in the reaction vessel.
- 3 Use the mole ratio from the balanced chemical equation to determine the number of moles of permanganate that was titrated.
- 4 Calculate the concentration of potassium permanganate that was titrated.

## DISCUSSION

- 1 Discuss any variations in the concentration of potassium permanganate that could arise and make suggestions for improving the accuracy of results.

## CONCLUSION

With reference to the data obtained and its analysis, write a conclusion based on the aim of this investigation

Redox titrations are useful for determining the amount of ascorbic acid (vitamin C) in particular foods. A redox titration is used because it specifically targets the ascorbic acid, while an acid–base titration would also react with the other acids present in foods. The ascorbic acid reacts with an iodine solution. Starch is used as the indicator. Redox titrations can also be used to analyse the alcohol (ethanol) content and the sulfur dioxide of wine.

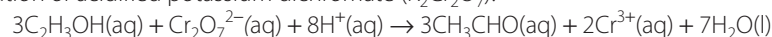
# INVESTIGATION 7.7

## Measuring the concentration of alcohol by titration

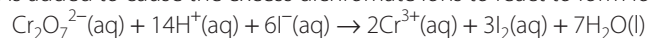
### INTRODUCTION

The concentration of alcohol (ethanol) is determined using a redox back titration. This involves a few steps.

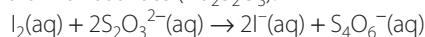
- 1 The ethanol is oxidised to ethanal (acetaldehyde) by warming a diluted sample of wine with an excess solution of acidified potassium dichromate ( $K_2Cr_2O_7$ ):



- 2 Potassium iodide is added to cause the excess dichromate ions to react to form iodine:



- 3 This iodine is titrated with sodium thiosulfate ( $Na_2S_2O_3$ ):



### AIM

To measure the concentration of alcohol by titration.



## » MATERIALS

- 10 mL wine
- 60 mL standard potassium dichromate solution ( $0.04 \text{ mol L}^{-1}$ )
- 100 mL of standard  $0.1 \text{ mol L}^{-1}$  sodium thiosulfate solution
- 30 mL of 40% sulfuric acid
- 6 g potassium iodide
- 250 mL distilled water
- Starch indicator (starch solution, freshly made)
- 10 mL pipette
- 2 × 20 mL pipettes
- Pipette filter
- 250 mL volumetric flask
- 3 × 250 mL conical flasks with stoppers
- 10 mL measuring cylinder
- Small filter funnel
- Burette and retort stand
- Burette clamp
- Hot water bath
- Thermometer
- Spatula
- Electronic balance
- White tile
- Gloves
- Safety glasses

WHAT ARE THE RISKS IN DOING THIS INVESTIGATION?	HOW CAN YOU MANAGE THESE RISKS TO STAY SAFE?
Sulfuric acid is corrosive.	Wear safety glasses and wash your hands at the end of the experiment.
Iodine solution stains skin, clothing and bench surfaces.	Avoid contact with iodine solution; wear gloves and a lab coat.
Potassium dichromate is a carcinogen.	Avoid exposure to the skin. Wear gloves and safety glasses.



What other risks are associated with this investigation? How can you manage these?

## METHOD

- 1 Pipette 10 mL of wine into a 250 mL volumetric flask.
- 2 Use distilled water to make the volume up to 250 mL and swirl to mix thoroughly.
- 3 From this diluted wine, take a 20 mL **aliquot** and put this in a conical flask.
- 4 Repeat step 3 twice so that there are three flasks.
- 5 To each flask add a 20 mL aliquot of  $0.04 \text{ mol L}^{-1}$  potassium dichromate solution.
- 6 Add 10 mL of 40% sulfuric acid to each flask using a measuring cylinder.
- 7 Stopper each flask loosely and heat for 10 minutes in a water bath at  $45\text{--}50^\circ\text{C}$ . Do not allow the water bath temperature to exceed  $50^\circ\text{C}$ .
- 8 After 10 minutes, remove the flasks from the bath and add 2 g of potassium iodide to each flask.
- 9 Fill a burette with standard thiosulfate solution.



- » **10** Titrate the contents of the flask with the thiosulfate solution. Add 1–2 mL of starch solution when the brown colour of the solution becomes green. The equivalence point of the titration is reached when the blue colour of the starch iodine complex just disappears, leaving a clear green colour.
- 11** Record the titres for each flask.

### RESULTS

Copy and complete the following results table.

FLASK	TITRE (mL)
1	
2	
3	
Average	

### ANALYSIS OF RESULTS

- Calculate the number of moles of  $\text{Cr}_2\text{O}_7^{2-}(\text{aq})$  ions in each 20 mL of potassium dichromate.
- Use the average titre of the standard sodium thiosulfate solution and calculate the number of moles of thiosulfate ions ( $\text{S}_2\text{O}_3^{2-}$ ) in this titre.
- Calculate the amount of iodine ( $\text{I}_2$ ) formed during the reaction with the excess dichromate.
- Use the equation for the reaction between the  $\text{Cr}_2\text{O}_7^{2-}$  and the  $\text{I}^-$  ions to deduce the amount of  $\text{Cr}_2\text{O}_7^{2-}$  ions in excess after the oxidation of the alcohol.
- By subtracting the amount of excess  $\text{Cr}_2\text{O}_7^{2-}$  ions from the original amount of  $\text{Cr}_2\text{O}_7^{2-}$  ions added to the diluted wine (calculated in question **1**), calculate the amount of  $\text{Cr}_2\text{O}_7^{2-}$  ions that reacted with the ethanol.
- Using the equation for the reaction between the ethanol and the  $\text{Cr}_2\text{O}_7^{2-}$  ions, find the amount of ethanol in each 20 mL aliquot of diluted wine.
- Calculate the amount of ethanol in the 250 mL volumetric flask.
- Find the molar mass of ethanol, and hence, calculate the mass of ethanol in the 10 mL sample of wine.
- Given that the density of ethanol is  $0.785 \text{ g mL}^{-1}$ , calculate the volume of ethanol in the 10 mL sample.
- Determine the percentage alcohol in the wine on a volume/volume basis.

### DISCUSSION

Compare your result with the alcohol content as specified by the label on the bottle. If there is a discrepancy between the two, suggest possible reasons for this.

### CONCLUSION

With reference to the data obtained and its analysis, write a conclusion based on the aim of this investigation.

## INVESTIGATION 7.8

### Determination of sulfur dioxide content of wine

Sulfur dioxide is used in wine-making for two reasons. It acts as an antioxidant and as an antimicrobial agent. Unfortunately, some people are allergic to this chemical. There is a legal limit for the total concentration of sulfur dioxide in wine.

Wine must have a concentration of sulfur dioxide of less than  $10 \text{ mg L}^{-1}$  to be classed as preservative free; otherwise, the wine label must indicate that preservative 220 has been added or that the wine contains sulfites. The maximum level for sulfur dioxide in Australian wine is  $300 \text{ mg L}^{-1}$ .

#### AIM

To determine the total mass of sulfur dioxide in wine by performing a redox titration.

#### MATERIALS

- 60 mL of white wine
- 40 mL of  $1 \text{ mol L}^{-1}$  NaOH
- 30 mL of  $2 \text{ mol L}^{-1}$   $\text{H}_2\text{SO}_4$
- Starch indicator, freshly prepared
- 100 mL of  $0.00500 \text{ mol L}^{-1}$  iodine
- 20 mL pipette
- Pipette filler
- 3 × 250 mL conical flasks
- 25 mL measuring cylinder
- 10 mL measuring cylinder
- Small filter funnel
- Burette and retort stand
- Burette clamp
- Safety glasses

WHAT ARE THE RISKS IN DOING THIS INVESTIGATION?	HOW CAN YOU MANAGE THESE RISKS TO STAY SAFE?
Sodium hydroxide and sulfuric acid are corrosive.	Avoid contact with skin. Wear gloves and a lab coat.
$\text{SO}_2$ gas may be produced.	Must be performed in a fume cupboard.
Glassware may be cracked or broken.	Handle glass with care. Inspect and discard any chipped or cracked beakers, no matter how small the damage. Sweep up broken glass with a dustpan and brush; do not use fingers.
Iodine solution stains skin, clothing and bench surfaces.	Avoid contact with iodine solution. Wear gloves and a lab coat.



What other risks are associated with this investigation? How can you manage these?

#### METHOD

- Use a pipette to transfer a 20 mL aliquot of wine into each 250 mL conical flask.
- Add approximately 12 mL of  $1 \text{ mol L}^{-1}$  NaOH to each conical flask and allow to stand for 15 minutes. This releases the  $\text{SO}_2$  bound in complex compounds in the wine.
- Rinse and fill the burette with  $0.00500 \text{ mol L}^{-1}$  iodine solution. Record your initial burette reading and concentration of the iodine.
- To one flask add approximately 10 mL of 2M sulfuric acid and 1–2 mL of the starch solution. Immediately titrate the mixture with iodine. Record the burette reading the moment the colour turns permanently blue (end point).
- Repeat the above steps with each of the other two flasks.



## » RESULTS

- 1 Calculate the average titre of the iodine solution.
- 2 Calculate the amount of iodine in moles in the average titre using the concentration of the iodine solution.

## ANALYSIS OF RESULTS

- 1 Write an ionic equation for the redox reaction that occurs during the titration given the half equations for the titration reactions are:  
$$\text{SO}_2(\text{aq}) + 2\text{H}_2\text{O}(\text{l}) \rightarrow 3\text{H}^+(\text{aq}) + \text{HSO}_4^-(\text{aq}) + 2\text{e}^-$$
$$\text{I}_2(\text{aq}) + 2\text{e}^- \rightarrow 2\text{I}^-(\text{aq})$$
- 2 Calculate the amount of sulfur dioxide present in each 20 mL aliquot of wine.
- 3 Calculate the amount of sulfur dioxide that would be present in 1 L of wine.
- 4 Calculate the mass of sulfur dioxide that would be present in 1 L of wine.

## DISCUSSION

- 1 Compare your results with the information on the wine bottle label. Do they agree?
- 2 Discuss possible sources of error in your result.

## CONCLUSION

Is the wine that you tested within the legal limits for  $\text{SO}_2$ ? What result did you find?

## EXTENSION

Winemakers may use commercial tests; for example,  $\text{SO}_2$  ampoules to determine the concentration of  $\text{SO}_2$  in the wine. Investigate the effectiveness of these commercial tests.

- A back titration is the method used to determine the mass or concentration of a substance that is not able to be determined directly.
- A redox titration is based on oxidation–reduction.

## CHECK YOUR UNDERSTANDING

7.4

- 1 Identify when a back titration may be used.
- 2
  - a What information is obtained when performing a conductometric titration?
  - b When would this type of titration be used?
- 3 How is the process of obtaining a titration curve different to that of obtaining a conductivity graph?
- 4
  - a Draw a pH curve for a titration between barium hydroxide and acetic acid. The barium hydroxide is in the burette.
    - b Identify the equivalence point.
  - a Draw a conductivity graph for the reaction between hydrochloric acid and ammonium hydroxide. The ammonium hydroxide is in the burette.
    - b Identify the equivalence point.
- 6 Some redox titrations do not require the use of an indicator. Explain how the end point is determined without the use of an indicator.
- 7 Explain why a pH meter was used to determine the end point for the experiment analysing the citric acid content of orange juice.







8 The following data table shows the results of a titration between 25 mL of  $0.100 \text{ mol L}^{-1}$  HCl and a NaOH solution of unknown concentration.

VOLUME OF NaOH (mL)	0.00	2.50	5.00	7.50	10.0	11.0	12.0	12.5	13.0	14.0	15.0	17.5	20.0	25.0
pH	1.00	1.14	1.30	1.51	1.85	2.08	2.57	7.00	11.42	11.89	12.10	12.37	12.52	12.7

Source of data: [https://chem.libretexts.org/Textbook\\_Maps/Analytical\\_Chemistry\\_Textbook\\_Maps/Map%3A\\_Analytical\\_Chemistry\\_2.0\\_\(Harvey\)/09\\_Titrimetric\\_Methods/9.2%3A\\_Acid%E2%80%93Base\\_Titrations#Practice\\_Exercise\\_9.1](https://chem.libretexts.org/Textbook_Maps/Analytical_Chemistry_Textbook_Maps/Map%3A_Analytical_Chemistry_2.0_(Harvey)/09_Titrimetric_Methods/9.2%3A_Acid%E2%80%93Base_Titrations#Practice_Exercise_9.1)

- Draw a titration curve using the data above.
  - Use the curve to determine the volume of NaOH at equivalence point.
  - Calculate the concentration of NaOH.
- 9 Some chemists suspected that their supply of sodium sulfite had been partially converted to sulfate by exposure to air over a long time. To determine the percentage of sulfite in their sample, they dissolved 0.781 g in 50 mL of  $0.308 \text{ mol L}^{-1}$  hydrochloric acid, boiled the solution gently to expel sulfur dioxide, then titrated the excess hydrochloric acid with  $0.144 \text{ mol L}^{-1}$  sodium hydroxide solution; 35.4 mL was required. Calculate the percentage of sodium sulfite in the sample.
- 10 A student conducted a titration using  $0.060 \text{ mol L}^{-1}$  solutions of both the acid and the base. The results were collected using a pH probe, then graphed. The data is shown on Figure 7.16.
- Identify the solution that was placed in the flask at the beginning of the titration, including specific details.
  - What volume of titrant was used?
  - Determine a volume that could have been used for the solution in the flask. Explain your reasoning.

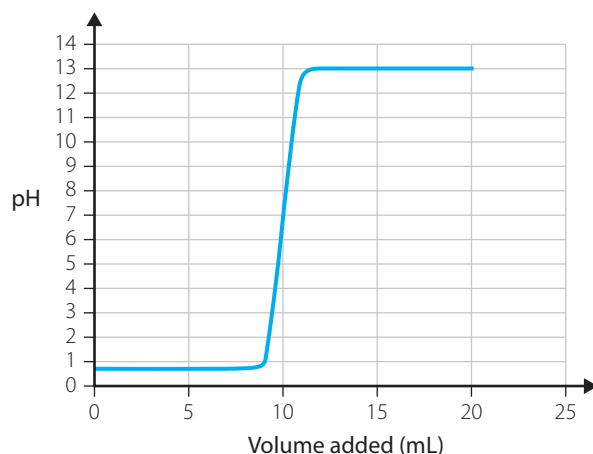


FIGURE 7.16 An acid–base titration

## 7.5 Keeping the balance

It is important that environments meet the needs of the organisms that live there. This means that conditions such as pH, concentration of ions and temperature are maintained at suitable levels. In a natural environment, the levels of these conditions in a particular environment will dictate what organisms are able to survive. For example, freshwater fish, such as the Murray cod, need to live in water with low concentrations of salt. However, marine fish, such as the clownfish, need to live in water with a higher salt concentration. Keeping biological systems in balance is also important to maintain the health of an organism.

### Buffers

**Buffers** are utilised in the natural environment and biological systems to maintain an optimal pH. Buffers are also important in many industries including the pharmaceutical industry, fermentation and food industry, the dyeing industry, printing industry and electroplating industry.

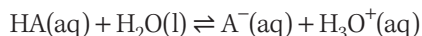
A buffer is a solution of a weak acid and its conjugate base (or vice versa) that is able to resist a change in pH when an acid or base is added. It achieves this due to the equilibrium established between the weak acid (or base) and the conjugate base (or conjugate acid). When an acid or base is added, the equilibrium will shift to counteract the addition. The concentration of hydronium ions returns to close to the original concentration and therefore the pH will remain constant.

An example is a solution of carbonic acid and sodium hydrogen carbonate ( $\text{H}_2\text{CO}_3/\text{HCO}_3^-$ ).

The pH of a buffer is determined by the:

- equilibrium constant  $K_a$  of the weak acid
- ratio of weak base  $[\text{A}^-]$  to weak acid  $[\text{HA}]$  in solution.

If a buffer has more acid than base, more  $\text{H}^+$  ions are present and the pH is lower. When the concentrations of  $\text{A}^-$  and  $\text{HA}$  are equal,  $[\text{H}^+]$  is equal to  $K_a$  and pH is equal to  $\text{p}K_a$ .



If a strong acid is added, according to Le Chatelier's principle, the extra  $\text{H}_3\text{O}^+$  pushes the equilibrium reaction to the left to partially reduce the concentration of  $\text{H}_3\text{O}^+$ . The pH increases to near the original value.

Addition of a strong base ( $\text{OH}^-$ ) will result in the added  $\text{OH}^-$  reacting with the  $\text{H}_3\text{O}^+$ . The system will try to oppose this change and move to produce more  $\text{H}_3\text{O}^+$ , shifting to the right. The pH is decreased to near the original value.

The pH is maintained by manipulating the proportion of weak base ( $\text{A}^-$ ) and weak acid ( $\text{HA}$ ) in solution. As long as  $[\text{A}^-]/[\text{HA}]$  is between  $\frac{1}{10}$  and 10, the pH is within 1 unit and the solution is therefore buffered.

The **buffer capacity** is the amount of the acid or base that can be added without a significant change in pH. The buffer capacity is greatest when there are equal number of moles of the weak acid and the conjugate base. This is because it is able to counteract the addition of both acids and bases. The buffer capacity is also affected by the actual amount of the weak acid and conjugate base. The more of each is present in the solution, the greater the buffer capacity. This is because there are more reactants and products present; therefore, both the forward and reverse reactions can occur to a greater extent to counteract the addition of acids and bases.



#### Buffer capacity

More information about buffering capacity

## INVESTIGATION 7.9

### Effect of buffers

#### INTRODUCTION

A buffer consists of a solution of a weak acid and its conjugate base (or vice versa). A buffer solution is prepared by mixing a solution of a weak acid (or base) with its conjugate base (or acid). The properties of the buffer allow constant pH to be maintained when acids and bases are added to the solution.

#### AIM

To compare the behaviour of a buffered solution with an unbuffered solution.

#### MATERIALS

- ▀ 10 mL of  $0.2 \text{ mol L}^{-1}$  acetic acid ( $\text{CH}_3\text{COOH}$ )
- ▀ 40 mL of  $0.2 \text{ mol L}^{-1}$  sodium acetate ( $\text{CH}_3\text{COONa}$ )
- ▀ 30 mL of  $0.1 \text{ mol L}^{-1}$  hydrochloric acid ( $\text{HCl}$ )
- ▀ 30 mL of  $0.1 \text{ mol L}^{-1}$  sodium hydroxide ( $\text{NaOH}$ )
- ▀ Distilled water
- ▀  $6 \times 150 \text{ mL}$  beaker
- ▀ 50 mL measuring cylinder
- ▀ Stirring rod



- » ■ 2 × plastic droppers
- Universal indicator and colour chart
- Safety glasses
- Disposable gloves and an apron

WHAT ARE THE RISKS IN THIS INVESTIGATION?	HOW CAN YOU MANAGE THESE RISKS TO STAY SAFE?
Chemicals may splash onto you skin or into your eyes.	Wear safety glasses and wash your hands at the end of the experiment.
0.1 mol L <sup>-1</sup> HCl is corrosive to skin and clothes.	Wear gloves and an apron.
0.1 mol L <sup>-1</sup> NaOH is corrosive.	Wear gloves and an apron.



What other risks are associated with your investigation? How can you manage these?

#### METHOD

- 1 Measure 10 mL of 0.2 mol L<sup>-1</sup> acetic acid (CH<sub>3</sub>COOH) and pour it into a clean, dry beaker.
- 2 Measure 40 mL of 0.2 mol L<sup>-1</sup> sodium acetate (CH<sub>3</sub>COONa) and add this to the acetic acid in the beaker.
- 3 Use a measuring cylinder to measure 20 mL of this solution into two beakers. Discard the remainder.
- 4 Add five drops of universal indicator to both beakers. Record the colour, and therefore pH, of the solutions. Label these beakers 'Buffered solution'.
- 5 Into a fourth beaker, add 50 mL of distilled water.
- 6 Add 10 drops of universal indicator to the water.
- 7 Add hydrochloric acid drop by drop to the distilled water until the colour is the same as the buffered solution.
- 8 Use a measuring cylinder to measure 20 mL of the solution from step 7 into two beakers and discard the remainder. Label these beakers 'Unbuffered solution'. Record the colour of these solutions.
- 9 To one of the buffered solutions add 0.1 mol L<sup>-1</sup> HCl one drop at a time until 40 drops have been added. Stir the solution between each drop.
- 10 Record the colour and pH of the resultant solution.
- 11 Repeat steps 9 and 10 for one of the unbuffered beakers.
- 12 Repeat steps 9–11 with the remaining beakers adding 0.1 mol L<sup>-1</sup> NaOH instead of HCl.

#### RESULTS

Copy and complete the following result table.

BEAKER	INITIAL COLOUR	INITIAL pH	FINAL COLOUR	FINAL pH	CHANGE IN pH
Buffered solution + 0.1 mol L <sup>-1</sup> HCl					
Buffered solution + 0.1 mol L <sup>-1</sup> NaOH					
Unbuffered solution + 0.1 mol L <sup>-1</sup> HCl					
Unbuffered solution + 0.1 mol L <sup>-1</sup> NaOH					

#### ANALYSIS OF RESULTS

- 1 Describe the pH change for each of the beakers.
- 2 Describe the difference between changes in the buffered and unbuffered solutions.
- 3 Use your understanding of equilibrium to account for these changes.



## » DISCUSSION

- 1 Suggest what would happen if you continued to add HCl to the buffered solution.
- 2 Suggest what would happen if you continued to add NaOH to the buffered solution.
- 3 What is the effect of having a buffer in the solution?
- 4 In what ways may the experiment be improved to provide more accurate results? Explain how each of your suggestions would facilitate this improvement.

## CONCLUSION

What conclusion can you make regarding the action of a buffer in a solution?

## EXTENSION

- 1 Your teacher may allow you to test the effect of adding more acid or base to the buffered solution to test your hypothesis.
- 2 How could you further test the effect of buffers?

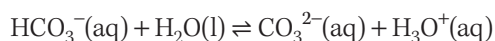
## Buffering in the environment

With increasing carbon dioxide levels in the atmosphere, there is a major concern that the oceans and soil are being acidified. In ocean waters, carbon dioxide is found in higher concentrations than other non-polar gases as it reacts with water. The changes in pH at these levels are significant and are altering the thickness of shells of aquatic organisms and the ability of organisms to take up calcium (Figure 7.17).



**FIGURE 7.17** Aquatic organisms need their environment to maintain a balance.

In sea water, the buffer is due to bicarbonate and carbonate ions. In this case, the bicarbonate is the weak acid and the carbonate is the conjugate base. This sets up the following equilibrium:



With increasing carbon dioxide levels in the atmosphere, there is a major concern that the oceans are being acidified. The breakdown of organic matter and fish waste also causes the water to become more acidic. The buffer is able to counteract this change so that the pH is not affected.

When an acid is added to natural bodies of water, the concentration of hydronium ions increases. According to Le Chatelier's principle, this leads to the reverse reaction being favoured to counteract the change. As the reverse reaction uses up hydronium ions, their concentration decreases, which means that the pH remains close to its original value despite the addition of an acid.

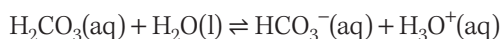
Calcium and magnesium ions cause the water to become more alkaline. This happens when items such as shells are added to the environment and when minerals in the surrounding soil are in run off entering the water. When a base is added to natural bodies of water it will react with the hydronium ions, neutralising them. This causes a decrease in their concentration. According to Le Chatelier's principle, the forward reaction will be favoured to counteract this change. The forward reaction produces hydronium ions; therefore, the pH will remain close to its original value despite the addition of a base.

The buffering in the natural aquatic system is able to counteract changes and maintain the original pH. Natural sea water has a pH of 8.0–8.3. At this pH, there are approximately equal amounts of bicarbonate and carbonate ions. This is the ideal situation because it allows the buffer to effectively counteract the addition of both acids and bases.

pH also plays a critical role in soils since most plants grow best in a pH range of 6.0–7.0. Acid rain can lead to acidification of the soil, leaching away beneficial nutrients and killing beneficial bacteria responsible for nitrification of the soil and the decomposition of organic matter. The minerals and organic matter in soil act as buffers.

## Buffering in biological systems

The pH of many biological systems are maintained within narrow ranges by buffers. The internal pH of most living cells is close to 7.0. The pH range for human blood is 7.35–7.45. The main buffer system in blood is the carbonic acid/hydrogen carbonate ion system:



If blood becomes too acidic, then the reverse reaction occurs to reduce the excess  $\text{H}_3\text{O}^+$ . If the blood becomes too basic, then the forward reaction occurs to increase the  $\text{H}_3\text{O}^+$  to neutralise the excess base.

This buffer is also involved in the transport of the waste carbon dioxide from the cells. Carbon dioxide is a clear odourless gas produced in every cell in the body. The carbon dioxide has to dissolve in blood, which is an aqueous medium in accordance to the reaction:



In enzyme-catalysed reactions, the dissolved carbon dioxide then reacts with water in the blood to form carbonic acid, as shown in reactions 7.2 and 7.3. The majority of the carbon dioxide is transported in the blood to the lungs as the hydrogen carbonate ion:



The acidity of the blood increases as more carbon dioxide is dissolved.





**FIGURE 7.18** Animals such as Australian seals have a high tolerance for carbon dioxide in their blood. This, in part, allows them to dive for extended periods of time.

Once the blood reaches the lungs, the reverse series of reactions occurs with the carbon dioxide gas diffusing into the air space in the lungs. Carbon dioxide is breathed out. The concentration of carbon dioxide in the lungs is lower than in blood. Reaction 7.1 proceeds to the left, which reduces the concentration of  $\text{CO}_2(\text{aq})$ . Reducing  $[\text{CO}_2(\text{aq})]$  has the effect of pushing reaction 7.2 to the left. This reduces  $[\text{H}_2\text{CO}_3]$  so that reaction 7.3 is also pushed to the left. Overall,  $[\text{H}_3\text{O}^+]$  decreases. The amount of  $\text{CO}_2$  in the blood is maintained within a narrow band, which helps prevent blood from becoming too acidic.

Sea-diving animals, such as whales, seals and dolphins, can stay under water for more than an hour (Figure 7.18). Other adaptations these organisms have include a higher tolerance for carbon dioxide in their blood compared to humans. Humans can generally only hold their breath for a couple of minutes. It is the high level of carbon dioxide, not the low level of oxygen, that causes the breathing reflex when holding one's breath.

- Buffers are utilised in the natural environment and biological systems to maintain an optimal pH.
- The buffer capacity is the amount of the acid or base that can be added without a significant change in pH.

## CHECK YOUR UNDERSTANDING

7.5

- 1 Define 'buffer' and give an example.
- 2 **a** What is buffering capacity?  
**b** Explain how the buffering capacity of a system could be increased.
- 3 An aqueous solution of ethanoic acid/ethanoate ion can act as a buffer.  
**a** What is a buffer solution?  
**b** Use Le Chatelier's principle to explain what happens when a small amount of the following is added.
  - i HCl
  - ii NaOH
- 4 The pH of sea water has fallen from 8.2 to 8.1 over the last 200 years.  
**a** Calculate the percentage change in  $[\text{H}_3\text{O}^+]$ .  
**b** One main concern is the ability of marine organisms to build calcium carbonate structures such as shells. Sea water is basic because it is naturally saturated with carbonate ion ( $\text{CO}_3^{2-}$ ), a base. Explain how this base is buffering the increase in acidity and how this is also causing the reduction of calcium carbonate-based structures such as shells.
- 5 It is a common practice for doctors to inject a solution of sodium hydrogen carbonate directly into the heart of a patient who has suffered cardiac arrest. Under cardiac arrest, the heart is not supplied with blood, and carbon dioxide builds up and death may follow.  
Use the following series of reactions to explain how the hydrogen carbonate might be of benefit to the patient.
 
$$\text{H}_2\text{CO}_3(\text{aq}) + \text{H}_2\text{O}(\text{l}) \rightleftharpoons \text{HCO}_3^-(\text{aq}) + \text{H}_3\text{O}^+(\text{aq}) \quad K_a = 4.5 \times 10^{-7}$$

$$\text{HCO}_3^-(\text{aq}) + \text{H}_2\text{O}(\text{l}) \rightleftharpoons \text{CO}_3^{2-}(\text{aq}) + \text{H}_3\text{O}^+(\text{aq}) \quad K_a = 4.7 \times 10^{-11}$$
- 6 Use an example to explain why buffers are important in natural systems.

The information in this chapter has focused on using volumetric analysis techniques to analyse a mixture to determine the quantity of a particular compound in the mixture. This technique is a classical method that has been used since the beginning of modern chemistry in the 19th century. You may also hear it referred to as wet analysis because it involves solutions. Today there are many instrumental methods that can be used to determine the presence of, and the relative amount of, a particular substance in a mixture.

Quantitative analysis is widely used in many different fields, including various industries, healthcare, environmental monitoring, forensics and chemical biology.

### Analysis techniques used in industry

In the food and beverage industry, titration techniques are widely used. For example, it can be used to determine the amount of salt or sugar in a product, the concentration of vitamin C or E and the amount of preservatives such as sulfur dioxide.

The use of analytical instruments in the wine industry allows scientists to learn more about the complex chemistry of wine and to discover the chemical pathways of some of the key molecules in wine.

The winemaker will monitor the production of alcohol during fermentation as part of quality control. It is a legal requirement that the final alcohol level be measured and reported on the bottle's label. There are various ways to determine the alcohol level, including by monitoring density changes and titration.

As fermentation proceeds, the density of the mixture decreases. This is due to ethanol's lower density ( $0.789\text{g mL}^{-1}$  at  $25^\circ\text{C}$ ) compared to that of water ( $1\text{g mL}^{-1}$ ). A hydrometer is one way of tracking the change in density. A titration, or more specifically a back titration, can be used to measure the alcohol content of wine.

Gas chromatography (GC) can detect the amount of ethanol and other alcohols such as methanol, which is naturally produced in the fermentation process in small quantities. Methanol is highly toxic. It can be fatal or cause permanent brain damage at quite low doses. Methanol must be present at less than  $2\text{g L}^{-1}$  of ethanol content for white wine and less than  $3\text{g L}^{-1}$  of ethanol in red wine. Higher levels in wine usually indicate that illegal tampering or adulteration of the wine has occurred.

The wine industry also uses infrared spectroscopy. A near-infrared spectrometer measures the alcohol content quicker and more reliably to produce better quality wines. A specific range of  $1150\text{--}1200\text{nm}$  is used so that the other constituents of the wine do not influence the result. This means the one procedure can work for white or red wine and sweet or dry wine.

The acidity of wine is one of the main factors that contribute to its taste. Acidity balances residual sugar and alcohol. There are more than 40 organic acids found in wine. These organic acids are weak acids. The pH of the fermentation mixture is also important since the enzymes in yeast have an optimum pH. The acid level in wine also helps the microbial action of  $\text{SO}_2$  (the main preservative); it helps desirable micro-organisms and enhances the wine's colour and flavour. The amount of acid present is measured by titration. In the wine industry, it is called the **titratable acidity**. Titration acidity consists of acids that can be titrated by a strong base solution by reaction with their free carboxylic acid groups ( $-\text{COOH}$ ). The use of automatic titrators is now common in most laboratories. These are devices designed to automatically complete the titration process and use digital probes to obtain the required measurements.

Sulfur dioxide is used to kill or inhibit unwanted yeasts and bacteria in wine and to protect the wine from oxidation. When sulfur dioxide is added to wine, there are three forms present: molecular  $\text{SO}_2$ ,  $\text{SO}_3^{2-}$  and  $\text{HSO}_3^-$ . Knowing both the amount of free and total sulfites is important because only the free forms of sulfites play a preservative role in wine. This is often expressed as 'ppm free  $\text{SO}_2$ /ppm total  $\text{SO}_2$ '



to denote which number is free and which is total. A redox titration of the wine using iodine with starch as the indicator can be used to measure the free  $\text{SO}_2$ .

The total  $\text{SO}_2$  can also be determined by titration. This requires the additional step of adding sodium hydroxide to break down the complexes binding the  $\text{SO}_2$ .

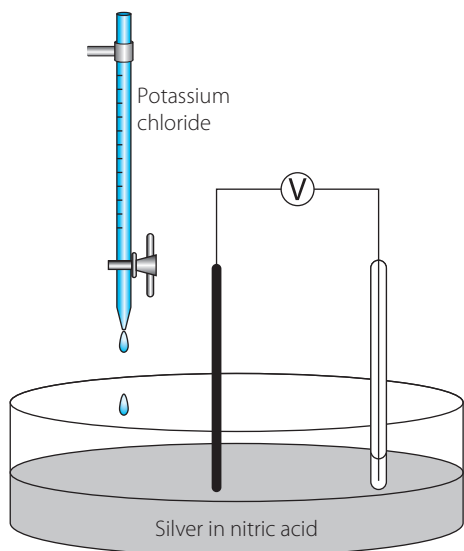
In the mining industry, metals, alloys and ores are analysed to determine their exact composition. A variety of chemical and instrumental methods are used, including assaying, atomic absorption spectroscopy (AAS), spectroscopy and titrations.

The first step in wet analysis involves dissolving the ore. This is done using particular acids or combinations of acids, depending on the chemical properties of the ore. For example, nitric acid is used to dissolve ores of Cd, Cu, Mo, Co, Ni, while a combination of  $\text{H}_3\text{PO}_4$  and  $\text{H}_2\text{SO}_4$  is used to dissolve fused  $\text{Al}_2\text{O}_3$  and chrome ores.

A series of titrations are then used, depending on the metals present, to obtain an analysis of the percentage composition of the ore. Today, spectroscopic methods are more commonly used than wet chemistry methods since these methods are more accurate and less time-consuming.

A type of titration used to determine the purity of silver, gold and palladium is called a potentiometric titration.

In this type of titration, there is no need for an indicator. Instead of using a chemical to determine the end point, the electric potential across the solution is measured. Ions in a solution are conductive; the more ions that are present, the higher the conductivity of the solution. Two electrodes are placed to measure the potential across the solution, as seen in Figure 7.19.



**FIGURE 7.19** Set-up for a potentiometric titration

To measure the amount of silver in an alloy, the silver sample is weighed, and then dissolved in nitric acid to form a silver nitrate solution. Potassium chloride solution is added via a burette, causing the silver ions to precipitate as silver chloride.

The end point of the titration is detected through a set of electrodes that measure the changes in the electrical conductivity of the solution due to the silver ions. As the silver ions precipitate, the conductivity decreases since fewer ions are present.

The amount of potassium chloride that was required to cause all the silver to precipitate is then used to calculate the mass of silver in the solution. This is compared to the mass of the original silver alloy sample and a percentage of silver in the sample is calculated.

The monitoring of acid mine drainage is very important in the mining industry. As you learnt in chapter 5, wastewater from mine drainage contains a large amount of acidity because of the presence of sulfuric acid produced from the oxidation of pyrite. This acid water is neutralised with calcium oxide before the land is reclaimed after mining. The acidity of wastewater can be determined by titrating against a standard NaOH solution while alkalinity is determined by titrating against a standard hydrochloric or sulfuric acid solution.

Chemical analysis of a substance is vital in the pharmaceutical industry. It is used in all aspects of the industry from drug development to final product in assessing the stability of the drug molecule, quantification of impurities and the content of the drug in the marketed product. Acid–base titrations are often used for salicylic acid and benzoic acid determinations. Widely used instrumental techniques include spectroscopy (infrared, atomic absorption, mass), chromatography (thin layer, gas and high performance liquid) and electrophoresis.



Check your understanding

## Indigenous peoples of Australia use of acids and bases

Aboriginal peoples have lived in the midst of the natural environment for thousands of years and in many regions continue to do so. Over generations, Aboriginal peoples have investigated, developed and exploited hundreds of native plant species for food and medicinal purposes. Through an investigative process involving observations and trial and error applications, they were able to identify and utilise the chemical and physical properties of materials for a variety of purposes.

While Indigenous Australians did not use the terms 'acid' and 'base', their use of plants and other natural substances demonstrated their understanding of the properties of these compounds. Subsequent chemical analysis by pharmacologists has identified the active ingredients in Australian plants used by Indigenous peoples. While not all Indigenous medicines have been investigated, many have contributed to the development of modern pharmaceuticals widely used today. For example, the pharmacological analysis of the corkwood tree (*Duboisia myoporoides*), used by Aboriginal groups as a narcotic and poison, led to the discovery of a drug that controls pupil dilation and which is widely used in eye surgery.

### Uses of the soap tree (*Alphitonia excelsa*)

The Kuku Yalanji people of the Daintree, along with other Indigenous peoples have many medicinal uses of the soap tree. They prepare a lather by crushing and rubbing leaves with a little water, as shown in Figure 7.20. The lather produced is rubbed on the skin as a cleanser and as an antiseptic for the treatment of rashes and ringworm.

Prior to colonisation, young leaf tips were chewed for an upset stomach, leaves were applied to sore eyes and warm water infused with leaves was applied across the head to reduce headaches. An infusion of the bark and root was rubbed on the body to relieve muscle aches or gargled to relieve toothache.

Analysis of the leaves has found they contain saponins, which tend to be acidic. The wood, bark and leaves contain many organic acids, and small amounts of methyl salicylate. The large size of the saponin molecules means one end of the molecule is hydrophilic and the other end is hydrophobic. This results in their ability to act as a mild soap by removing dirt particles. The methyl salicylate is thought to be responsible for the [analgesic](#) properties of the plant.

### Treating stings

There are many plants that were used by Indigenous peoples to treat different types of stings. The plants used depended on availability in different locations. In Queensland, the chewed leaf and juice of the hop-bush (*Dodonaea viscosa*) was put on stingray and stonefish stings and bound up for 4–5 days. The peanut tree (*Sterculia quadrifida*) was also used by the Indigenous peoples of North Queensland who placed heated leaves on the site of stings and bites caused by insects and marine creatures.

In Western Australia, pig face (*Carpobrotus glaucescens*) leaf juice was applied to stings from marine animals such as jellyfish.



FIGURE 7.20 Using soap tree to cleanse the skin

Groups from northern Australia and parts of New South Wales used the plant goats foot (*Ipomea pes-caprae*) to treat stingray and stonefish stings. The leaves of the plant were crushed and heated then applied directly to the skin.

The grey mangrove, also called the white mangrove (*Avicennia marina*), is widely distributed along the Australian coastline. It has been used to relieve the pain of stingray and stonefish stings. The leaves and young shoots are chewed and the mixture applied directly to the wound.

The plant known to the Indigenous people as *Nipan* (*Capparis lasiantha*) is found throughout northern tropical Australia (except the coast). An infusion of whole mashed plant in water is applied externally to treat snakebite, insect bites and stings.

The analysis of many of the plants mentioned in this section has shown the presence of **alkaloids**. While the medical properties of alkaloids are quite diverse, many are used for pain relief and possess anaesthetic properties.

## Use of clay

While the use of ochres and white clay as paints/pigments for domestic and ceremonial purposes is well-known in the mainstream, the use of clay and ochre in Aboriginal medicine is not. Ochre was also used to preserve food, which could be used in times of shortage. Plant food such as berries were packed inside a ball of ochre and buried. These could later be retrieved and used. When coated with ochre, domestic and hunting tools were protected against termites.

Many Indigenous groups used ochre and clay to treat ailments. It was either applied directly to the skin or ingested. In Arnhem Land, Indigenous peoples ate small balls of white clay and pieces of termite mound to cure diarrhea and stomach upsets. Other groups would eat small balls of white clay and ochre to cure gastrointestinal toxins produced by infection. In many parts of Australia, clay and sediment was used to cover wounds, providing a physical barrier to infection.

The colours of ochre are due to the presence of an iron oxide or iron hydroxide, as shown in Figure 7.21. Yellow ochre is hydrated iron hydroxide ( $\text{FeO}(\text{OH}) \cdot n\text{H}_2\text{O}$ ), red ochre is anhydrous iron oxide ( $\text{Fe}_2\text{O}_3$ ), brown ochre is partly hydrated iron oxide ( $\text{FeO}(\text{OH})$ ), while white ochre has little or no iron. The white colour comes from kaolin, which is a white clay mineral –  $\text{Al}_2(\text{Si}_2\text{O}_5)(\text{OH})_4$ .



**FIGURE 7.21** Iron oxide deposit

In current medicine, the ingestion of dried clay minerals or a clay suspension is commonly used as a detoxifying agent and to treat gastrointestinal illness. The alkaline nature of the clay and ochre helps neutralise excess stomach acid in much the same way as an indigestion tablet. The addition of iron oxide also provides an essential mineral that may be lacking in diets. Research has also shown that kaolin clay can absorb commonly ingested toxins, thus lowering food toxicity and improving digestive health.

Clay also has absorption capabilities and has been used externally to remove oils, secretions, toxins and impurities from the skin.

There is still much to learn from First Nations' peoples' pharmaceuticals and their use of natural materials.

# 7 CHAPTER SUMMARY

## IMPORTANT NEW TERMS

After studying this chapter you should know the meaning of the following terms:

accuracy (p. 191)

aliquot (p. 217)

alkaloid (p. 230)

analgesic (p. 229)

analyte (p. 198)

back titration (p. 208)

buffer (p. 221)

buffer capacity (p. 222)

conductometric titration (p. 206)

end point (p. 191)

equivalence point (p. 190)

parallax error (p. 191)

primary standard (p. 196)

quantitative analysis (p. 190)

tare (p. 196)

titrant (p. 198)

titratable acidity (p. 227)

titration (p. 190)

volumetric analysis (p. 190)

## AFTER STUDYING THIS CHAPTER YOU SHOULD KNOW:

- ▶ the definitions for all terms in the important new terms list
- ▶ quantitative analysis involves the measurement of numerical data
- ▶ the difference between equivalence point and end point
- ▶ the correct technique for preparing volumetric flasks, pipettes and burettes for use
- ▶ the colour changes for common acid–base indicators
- ▶ the criteria for a substance to be used as a primary standard:
  - large molar mass
  - cheap
  - high purity
  - stable in the presence of air
  - absence of any water of hydration
  - dissolves readily in solvent
- ▶ the correct technique for performing a titration
- ▶ how to choose the appropriate indicator for specific types of acid–base titrations
- ▶ the shapes of titration curves for different types of acid–base reactions
- ▶ the shapes of conductivity curves for different types of acid–base reactions
- ▶ the different types of titrations: acid–base titrations, back titrations and redox titrations

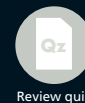
- ▶ buffer systems are conjugate acid–base pairs
- ▶ the importance of buffers in natural systems and how they maintain pH
- ▶ analysis techniques applied to industry
- ▶ Aboriginal and Torres Strait Islander People use of acids and bases.

## YOU SHOULD BE ABLE TO:

- ▶ use volumetric flasks, pipettes and burettes to measure accurate volumes of solutions
- ▶ read volumes accurately without parallax error
- ▶ use indicators to classify solutions as acidic, basic or neutral
- ▶ prepare a primary standard solution
- ▶ calculate the concentration of a solution, given the mass of solute and volume of solution
- ▶ perform a titration to obtain valid, reliable and accurate results
- ▶ use volumetric analysis to calculate the concentration of an unknown solution using the:
  - concentration of known solution
  - volume of known solution
  - volume of unknown solution
- ▶ use pH curves and conductivity graphs to determine the end point of a titration.

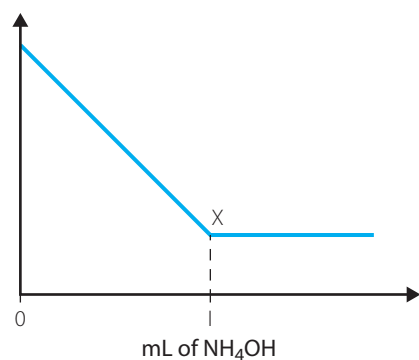


# 7 CHAPTER REVIEW QUESTIONS



Review quiz

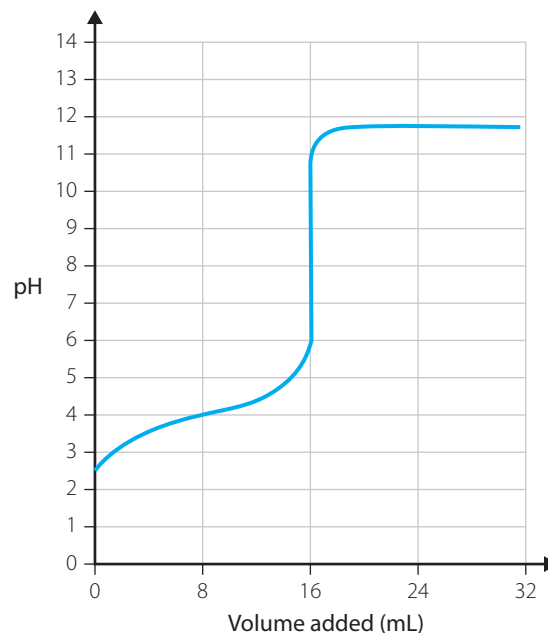
- Identify the colour change for phenolphthalein indicator.
- What is the end point of a titration?
  - What is the difference between end point and equivalence point?
- Identify two methods for determining when the end point of a titration has been reached.
- Identify three possible sources of error when using a burette.
- A student performed a titration between sodium hydroxide and a known concentration of sulfuric acid. The student put the sodium hydroxide in the burette and the sulfuric acid was pipetted into the reaction vessel. Prior to using the pipette, the student rinsed it with some distilled water. How would this affect the results?
- Why is the reaction vessel (conical flask) rinsed with distilled water rather than the solutions used in the titration?
- The same indicator cannot be used for a strong acid–weak base titration and a weak acid–strong base titration. Explain why not.
- Justify why anhydrous sodium carbonate can be used as a primary standard.
- Distinguish between a primary standard solution and a standard solution.
- Figure 7.22 shows the conductivity graph for a reaction between sulfuric acid and ammonium hydroxide.



**FIGURE 7.22** Conductivity graph for a titration between  $\text{H}_2\text{SO}_4$  and  $\text{NH}_4\text{OH}$

- What does the point labelled X signify?
- Explain why the conductivity falls then levels out.

- 3.25 g of barium hydroxide was used to make 100 mL of solution. 20 mL of this solution was titrated with 17.80 mL of hydrochloric acid.
  - Write a balanced equation for this reaction.
  - Identify an appropriate indicator that can be used for this titration. Justify your answer.
  - Identify the colour change that will occur at the end point for the indicator identified in part b.
  - Calculate the concentration of the hydrochloric acid solution.
- 25.00 mL of hydrogen peroxide solution was diluted to 250.00 mL using a volumetric flask. 20.0 mL of the diluted hydrogen peroxide solution was titrated with 19.60 mL of  $0.0200 \text{ mol L}^{-1}$  acidified potassium permanganate. The equation for this reaction is:
 
$$2\text{MnO}_4^-(\text{aq}) + 5\text{H}_2\text{O}_2(\text{aq}) + 6\text{H}^+(\text{aq}) \rightarrow 2\text{Mn}^{2+}(\text{aq}) + 5\text{O}_2(\text{g}) + 8\text{H}_2\text{O}(\text{l})$$
  - Identify the reducing agent in this titration.
  - Outline how the end point of this titration will be determined.
  - Calculate the concentration of hydrogen peroxide in the original solution.
- Look at the pH curve for the titration in Figure 7.23.



**FIGURE 7.23** A pH curve for a titration

- Identify the solution that was pipetted into the reaction vessel.
- Give an example of the type of acid that could have been used in this titration.
- Determine the pH of the end point for this titration.

- 14 The following data table gives the results of a titration between 25.0 mL  $\text{NH}_4\text{OH}$  with  $0.0625 \text{ mol L}^{-1}$  HCl.

VOLUME OF HCl (mL)	0.00	10.0	20.0	30.0	40.0	50.0	60.0	70.0	80.0	90.0	100
pH	11.17	9.84	9.42	9.07	8.64	5.31	2.13	1.88	1.75	1.66	1.60

Source of data: [https://chem.libretexts.org/Textbook\\_Maps/Analytical\\_Chemistry\\_Textbook\\_Maps/Map%3A\\_Analytical\\_Chemistry\\_2.0\\_\(Harvey\)/09\\_Titrimetric\\_Methods/9.2%3A\\_Acid%E2%80%93Base\\_Titrations#Practice\\_Exercise\\_9.1](https://chem.libretexts.org/Textbook_Maps/Analytical_Chemistry_Textbook_Maps/Map%3A_Analytical_Chemistry_2.0_(Harvey)/09_Titrimetric_Methods/9.2%3A_Acid%E2%80%93Base_Titrations#Practice_Exercise_9.1)

- a** Draw a titration curve using the data provided.
- b** Use the curve to determine the volume of HCl at equivalence point.
- c** Calculate the concentration of  $\text{NH}_4\text{OH}$ .
- 15 A student wanted to determine the nitrogen content, present as  $\text{NH}_4^+$ , in lawn fertiliser. A 1.432 g sample of the fertiliser was boiled with 25.00 mL of NaOH solution of concentration  $1.020 \text{ mol L}^{-1}$ . The excess NaOH was titrated against hydrochloric acid of concentration  $0.2154 \text{ mol L}^{-1}$ , using bromothymol blue indicator. A titre of 19.82 mL was required.
- What was the percentage by mass of ammonium ions in the fertiliser?
- 16 The phosphate buffer system works in the internal fluid of all cells that have a pH of 7. It is also widely used in laboratories to buffer solutions at pH around 7. It consists of an aqueous mixture of dihydrogen phosphate ions ( $\text{H}_2\text{PO}_4^-$ ) and hydrogen phosphate ions ( $\text{HPO}_4^{2-}$ ) in equilibrium with each other.
- a** Write the balanced equation to show the buffer system.
- b** Identify the acid and its conjugate base.
- c** Explain how this system maintains approximately constant pH even when additional hydrogen ions or hydroxide ions enter the system.
- 17 Two students were checking the volume in a burette. One student said that the volume was 37.30 mL, while the other student said that it was 36.90 mL. Explain how the two students might have recorded different values.
- 18 Give an example of the use of volumetric analysis in an industry and the different analytical techniques used.
- 19 Discuss, using examples, Australian Indigenous peoples' knowledge and use of acids and bases.
- 20 Discuss the usefulness of volumetric analysis as part of a chemist's toolbox.



Answer the following questions.

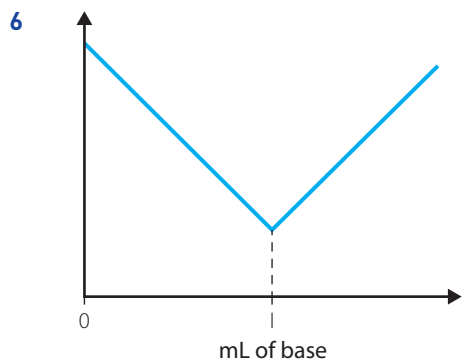
- 1 Which of the following statements about the reactions of acids is *not* correct?
- A Acids neutralise bases.
  - B Acids react with metals to produce a salt and hydrogen gas.
  - C Acids react with non-metals to produce a salt and oxygen gas.
  - D Acids react with carbonates to produce a salt, water and carbon dioxide gas.

- 2 A Brønsted–Lowry base is defined as:
- A a proton acceptor.
  - B a proton donor.
  - C a substance that produces  $\text{OH}^-$  ions in aqueous solution.
  - D an electron acceptor.

- 3 Which of these acids is monoprotic?
- A  $\text{CH}_3\text{COOH}$
  - B  $\text{H}_2\text{SO}_4$
  - C  $\text{H}_2\text{S}$
  - D  $\text{H}_2\text{PO}_4^-$

- 4 Which of the following species is amphiprotic in aqueous solution?
- |                    |                      |
|--------------------|----------------------|
| A HCl              | C $\text{NH}_4^+$    |
| B $\text{HCO}_3^-$ | D $\text{SO}_4^{2-}$ |

- 5 Which of the following is the correct process to use in order to make up a  $0.1 \text{ mol L}^{-1}$  solution of sodium carbonate?
- A Dissolve 0.01 moles of sodium carbonate in exactly 100 mL of water.
  - B Dissolve 0.1 moles of sodium carbonate in 100 mL then add a further 900 mL.
  - C Dissolve 0.1 moles of sodium carbonate in water and add more water until the volume is 1000 mL.
  - D Add 999 g of water to 1 g of sodium carbonate and stir until dissolved.



The conductivity graph shows the how conductivity changes when:

- A a strong acid is added to a strong base.
- B a weak base is added to a strong acid.
- C a weak acid is added to a strong base.
- D a weak base is added to a weak acid.

Use the following information for questions 7 & 8.

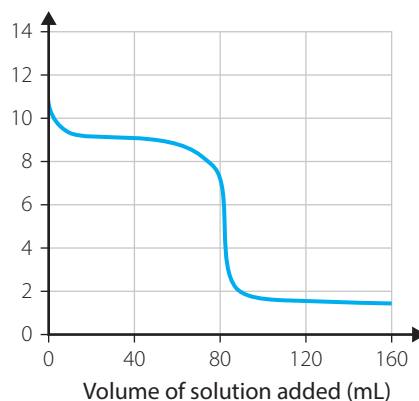
Base dissociation constants ( $K_b$ ) of four weak bases are as follows:

- I hydrazine =  $8.5 \times 10^{-7}$
- II morphine =  $7.4 \times 10^{-7}$
- III ammonia =  $1.8 \times 10^{-5}$
- IV ethylamine =  $4.3 \times 10^{-4}$

- 7 Which of the following gives the correct order of increasing basicity?
- A IV, I, III, II
  - B I, III, II, IV
  - C II, I, III, IV
  - D IV, III, I, II

- 8 Which of the above bases would have the strongest conjugate acid?
- |      |       |
|------|-------|
| A I  | C III |
| B II | D IV  |

- 9 The following graph represents the pH changes during an acid–base titration.



Listed below are four indicators and the pH range at which they change colour. Which one is the best to use for identifying the end point of the above titration?

- A Methyl orange (pH range 3.1–4.4)
- B Bromocresol green (pH range 3.8–5.4)
- C Phenol red (pH range 6.8–8.4)
- D Phenolphthalein (pH range 8.3–10)

- 10 Acid–base indicators are weak acids that have a conjugate base which is a different colour. The  $pK_a$  values of four indicators are given below:

INDICATOR	$pK_a$
Methyl yellow	3.1
Methyl red	5.1
Cresol red	8.3
Nile blue	9.7

Which would be the most suitable for a titration between acetic acid and sodium hydroxide?

- A Methyl yellow  
 B Methyl red  
 C Cresol red  
 D Nile blue
- 11 A, B, C, D, and E are  $0.1 \text{ mol L}^{-1}$  solutions containing a weak or a strong acid or base. The pH value of each of these solutions are listed in the table below:

SOLUTION	pH
A	12.12
B	0.69
C	13
D	1
E	2.87

Identify which one of A–E is a diprotic acid and explain your choice.

- 12 A student prepares four aqueous solutions in small beakers, then measures the pH with a pH meter and the electrical conductivity with a circuit containing a milliammeter, giving the following results:

	MILLIAMMETER READING (mA)	pH METER READING
<b>Beaker I</b> $0.1 \text{ mol L}^{-1}$ hydrochloric acid	270	1
<b>Beaker II</b> $0.1 \text{ mol L}^{-1}$ acetic acid	4	3
<b>Beaker III</b> Solution containing both $0.1 \text{ mol L}^{-1}$ hydrochloric acid and $0.1 \text{ mol L}^{-1}$ sodium chloride	340	1
<b>Beaker IV</b> Solution containing both $0.1 \text{ mol L}^{-1}$ hydrochloric acid and $0.1 \text{ mol L}^{-1}$ sodium acetate	70	3

Compare the conductivity and pH reading in beaker IV with the other three beakers and give an explanation for the values in beaker IV.

- 13 Students were given the following problem in an exam.

a In beaker A,  $50 \text{ mL}$  of  $1.0 \text{ mol L}^{-1}$  HCl is reacted with  $30 \text{ mL}$  of  $0.70 \text{ mol L}^{-1}$  NaOH.

In beaker B,  $50 \text{ mL}$  of  $1.0 \text{ mol L}^{-1}$   $\text{CH}_3\text{COOH}$  is reacted with  $30 \text{ mL}$  of  $0.70 \text{ mol L}^{-1}$  NaOH.  
 $(K_a \text{ of } \text{CH}_3\text{COOH} = 1.7 \times 10^{-5})$

Will the pH of the final solutions be the same?

Lee's answer was 'yes they will be the same'.

Eva's answer was 'no they will be different'.

Which student is correct? Support your choice with calculations showing the final pH of each solution.

b If the species in the solutions were swapped so:

In beaker A,  $50 \text{ mL}$  of  $1.0 \text{ mol L}^{-1}$  NaOH is reacted with  $30 \text{ mL}$  of  $0.70 \text{ mol L}^{-1}$  HCl.

In beaker B,  $50 \text{ mL}$  of  $1.0 \text{ mol L}^{-1}$  NaOH is reacted with  $30 \text{ mL}$  of  $0.70 \text{ mol L}^{-1}$   $\text{CH}_3\text{COOH}$ .

$(K_b \text{ of } \text{CH}_3\text{COO}^- = 5.8 \times 10^{-10})$

Would the pOH of the final solutions be the same?

Justify your answer without using calculations.

- 14  $1 \text{ mL}$  of concentrated nitric acid was sealed into a glass ampoule and placed in a calorimeter containing exactly  $100 \text{ mL}$  of  $0.100 \text{ mol L}^{-1}$  NaOH solution at  $25.6^\circ\text{C}$ . The ampoule is broken under conditions of continuous stirring and the temperature rises to  $26.9^\circ\text{C}$ .

A  $25.0 \text{ mL}$  aliquot of the solution in the calorimeter is titrated against a  $0.100 \text{ mol L}^{-1}$  sodium hydroxide solution.  $11.3 \text{ mL}$  of sodium hydroxide is required to neutralise the acid.

(Specific heat of water =  $4.18 \text{ JK}^{-1} \text{ g}^{-1}$ )

- a Calculate the heat of neutralisation for the reaction in the calorimeter.  
 b List any assumptions you made in performing the calculation in part a.  
 c Calculate the concentration of the nitric acid in the glass ampoule.

- 15 A patient is admitted to hospital and is observed to be hyperventilating (breathing rapidly and shallowly so that her oxygen intake increases). The patient also has a high temperature and is in great distress. The patient's blood pH is measured and found to be 7.15. Blood normally has a pH of 7.4. The doctor diagnoses the patient's condition as due to untreated diabetes.

a Compare quantitatively the hydrogen ion concentration in normal blood plasma with that of the patient.

The equilibrium reaction involving haemoglobin (Hb) and hydrogen ions that balances the blood pH is:



- b** Use the information above to explain the pH changes that have occurred in the patient's blood.  
One of the major buffering reactions in the blood is:  
 $\text{CO}_2(\text{aq}) + \text{H}_2\text{O}(\text{l}) \rightleftharpoons \text{HCO}_3^-(\text{aq}) + \text{H}^+(\text{aq}) \dots$  Equation 2
- c** Give the conjugate base to  $\text{HCO}_3^-$ .
- d** Explain what a buffer is.
- e** The doctor decides to inject a solution of hydrogen carbonate ( $\text{HCO}_3^-$ ) ions. Explain fully how this will help the patient (show any relevant equations).

- 16** Two groups of students were asked check the concentration of ammonia in a particular brand of cleaning product because there had been complaints about that brand. The students placed a 25.0 mL sample of cleaning product in a volumetric flask and made it up to 250 mL using distilled water. They then performed a titration by using 25.0 mL of the diluted ammonia solution in a conical flask and 0.10 mol L<sup>-1</sup> hydrochloric acid in the burette. One group used bromocresol green (pH range 4.0–5.6) as the indicator and obtained the following results.

TITRATION	1st	2nd	3rd	4th
VOLUME OF HCl ADDED (mL)	23.2	22.9	22.8	22.9

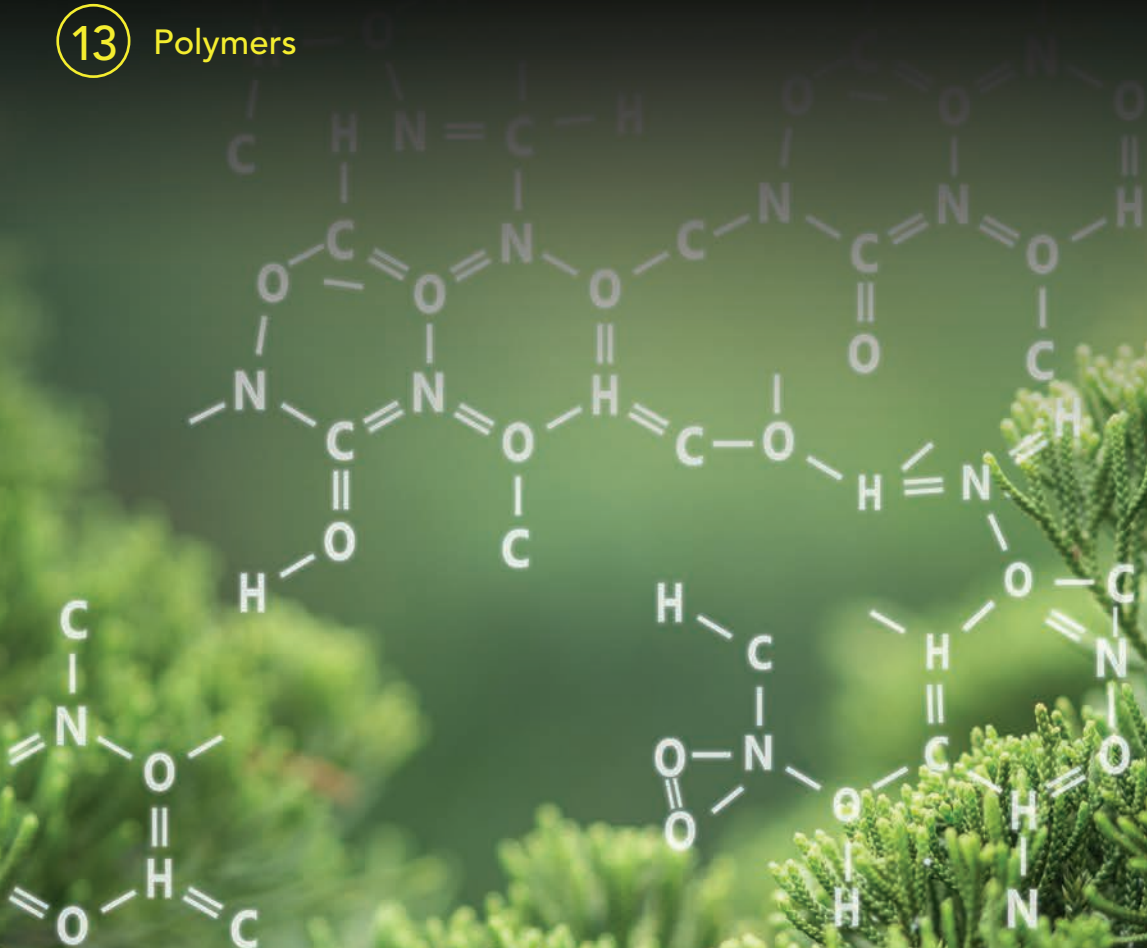
- a** Calculate the concentration of the diluted sample.
- b** Calculate the concentration of ammonia in 1 L of the original sample.
- c** Another group wanted to use phenol red for this titration (pH range 6.4–8). Is this an appropriate indicator? Fully explain your opinion.
- 17** Ethylamine ( $\text{C}_2\text{H}_5\text{NH}_2$ ) is a weak base and can be represented by B.
- a** Write the equation for the dissociation of a weak base in water.
- b** Write the expression for the base dissociation constant ( $K_b$ ) for this reaction.
- c**  $K_b = 4.3 \times 10^{-4}$ , for the dissociation of ethylamine. Calculate  $K_a$  for its conjugate acid.
- d** Calculate the pH of a 0.10 mol L<sup>-1</sup> solution of this base.
- e** In this calculation, you made an approximation. Explain what this approximation was and why it is a valid approximation to make.

### DEPTH STUDY SUGGESTIONS

- Conduct an investigation of the pH changes in a range of natural indicators and use these to make a 'natural' universal indicator.
- Conduct an investigation to measure the percentage ionisation of a weak acid or base.
- Conduct research into the buffer system used in swimming pools.
- Conduct an investigation into the effectiveness of different brands of antacids.
- Conduct an investigation to measure the acid or alcohol or sulfur dioxide content of wine.
- Conduct an investigation to measure the aspirin content of different brands of tablets.
- Research how increased atmospheric carbon dioxide is affecting the ocean's natural buffering system.
- Research the use of plant saps to neutralise stings.
- Create a presentation to demonstrate the amphiprotic nature of some salts.
- Create a presentation to show how the understanding of acids and bases has changed over time.

# ORGANIC CHEMISTRY

- 8 Hydrocarbons
- 9 Functional group compounds
- 10 Hydrocarbon reactions
- 11 Alcohols
- 12 Reactions of organic acids and bases
- 13 Polymers



## 8

## Hydrocarbons

## INQUIRY QUESTION

How do we systematically name organic chemical compounds?

## INQUIRY QUESTION

How can hydrocarbons be classified based on their structure and reactivity?

## Students:

investigate the nomenclature of organic chemicals, upto C<sub>8</sub>, using IUPAC conventions, including simple methyl and ethyl branched chains, including: ACSCH12) ICT

- alkanes
- alkenes
- alkynes
- halogenated organic compounds

explore and distinguish the different types of structural isomers, including saturated and unsaturated hydrocarbons, including: ACSCH03) ICT

- chain isomers
- position isomers

construct model, identify the functional group, and write structural and molecular formulae for homologous series of organic chemical compounds, up to C<sub>8</sub> ACSCH03) ICT

- alkanes
- alkenes
- alkynes

conduct an investigation to compare the properties of organic chemical compounds within a homologous series, and explain these differences in terms of bonding ACSCH03)

analyse the shape of molecules formed between carbon atoms when a single, double or triple bond is formed between them

explain the properties within and between the homologous series of alkanes with reference to the intermolecular and intramolecular bonding present. ICT

Chemistry Stage 6 Syllabus © NSW Educational Standards Authority for and on behalf of the Crown in right of the State of New South Wales, 2017



Carbon is found in more places and in more forms than any other element. Carbon forms more compounds than any other element. More than 90 per cent of compounds known to chemists are carbon compounds and there is a branch of chemistry, **organic chemistry**, devoted to carbon-based compounds. One of the main reasons for this is that carbon readily bonds to other carbon atoms and each atom can form a total of four bonds from single to double to triple.

There are millions of natural and synthetic organic compounds and every day new ones are being synthesised or isolated. In order to work effectively with the large number of organic compounds, chemists have developed a classification system based on the structural features of compounds. The types of atoms present in a molecule and the way in which they are arranged determines the physical and chemical properties of the molecule.



**FIGURE 8.1** An organic chemist at work



Prior knowledge

## 8.1 Bonding in carbon

In **organic compounds**, carbon atoms almost always form four bonds. For this to occur, the four valence electrons must be involved in the bonding. In simple carbon-based compounds such as alkanes, there are four identical bonds and a tetrahedral orientation of the electron pairs with an angle of  $109.5^\circ$  between bonds.

One, two or three pairs of the valence electrons from adjoining carbon atoms may be involved in the bonding to form:

- ▶ single bonds (one shared pair of electrons)  $C-C$
- ▶ double bonds (two shared pairs of electrons)  $C=C$
- ▶ triple bonds (three shared pairs of electrons)  $C\equiv C$ .

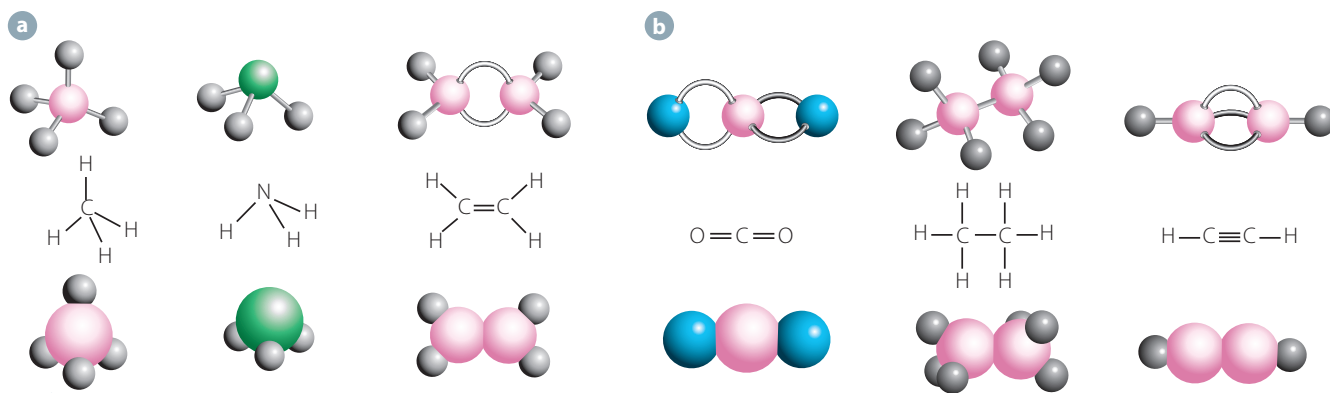
When four carbon atoms bond to each other, a different type of substance forms. Covalent network lattices of four carbon atoms bond together form diamond, as well as other allotropes of carbon you learned about in the Year 11 course.

Valence electrons not involved in forming carbon-carbon bonds form bonds with other elements, typically hydrogen, oxygen and nitrogen.

The physical appearance of molecules can be visualised by **space-filling models**. However, these models do not show the nature of the chemical bonding very clearly so chemists use **ball and stick models** in which the atoms are represented by balls and the bonds by sticks. Figure 8.2 (page 240) shows a comparison of these two models with their structural formula.

Table 8.1 (page 240) provides a summary of the geometrical arrangement of bonds around carbon atoms.





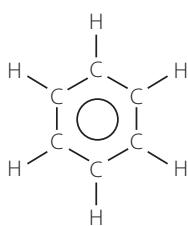
**FIGURE 8.2** Ball and stick models, structural formulae and space-filling models of **a** methane, ammonia and ethene; and **b** carbon dioxide, ethane and ethyne

**TABLE 8.1** Geometrical arrangement of bonds around carbon atoms

BONDS AROUND THE C ATOM	ARRANGEMENT OF BONDS AROUND THE CARBON ATOM	GEOMETRICAL ARRANGEMENTS OF THE BONDS	ANGLE BETWEEN BONDS	EXAMPLE
Four single bonds		Tetrahedral	109.5°	Methane
One double and two single bonds		Planar	120°	Ethene
Two double bonds		Linear	180°	Carbon dioxide
One triple and one single bond		Linear	180°	Ethyne

Key:

is the symbol for the benzene ring shown below. The ring represents a ring of shared electrons.



**FIGURE 8.3** The basic structure of benzene

## Types of hydrocarbons

**Hydrocarbons** are compounds made up of only hydrogen and carbon. Almost all other organic compounds are considered to be derivatives of simple hydrocarbons. Hydrocarbons can be classified as aliphatic or aromatic.

**Aromatic hydrocarbons** contain one or more **benzene** rings, as seen in Figure 8.3. Benzene will be discussed in more detail later in this chapter.

**Aliphatic compounds** are all the other hydrocarbons. The carbon atoms may be bonded in chains or non-aromatic rings. The chain compounds may be further classified into families on the basis of individual carbon–carbon bonds.

The family of chain hydrocarbon compounds where all the carbon–carbon bonds are single bonds are called the **alkanes**. Compounds with only single bonds between carbon atoms are called **saturated compounds**.

The family of chain hydrocarbon compounds in which at least one of the carbon–carbon bonds is a double bond are called the **alkenes**. Compounds with at least one multiple bond (double or triple) between carbon atoms are called **unsaturated compounds**.

There are two other families of aliphatic hydrocarbons – alkynes and alicyclic compounds. **Alkynes** are the family of chain hydrocarbons that have at least one carbon–carbon triple bond. Like alkenes, alkynes are classified as unsaturated compounds.

Hydrocarbon compounds in which the carbon atoms have joined to form a closed ring structure are called **alicyclic**, or more commonly, **cyclic hydrocarbons**. Cyclic hydrocarbons containing from as few as three to as many as 30 carbon atoms have been identified. Five and six-membered rings are the most common in nature.

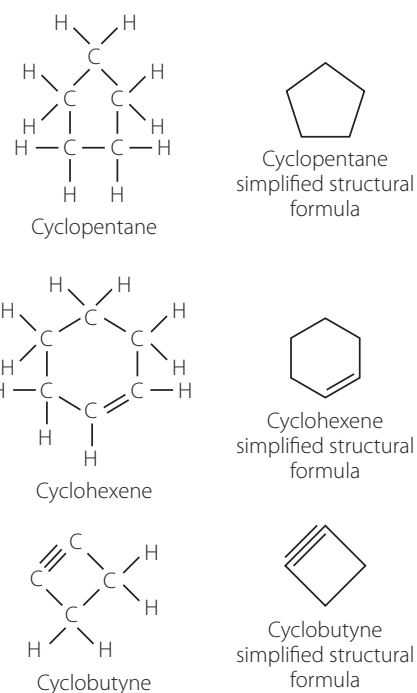
Cyclic hydrocarbons may be saturated or unsaturated. Those that contain only C—C single bonds are cycloalkanes, those with C=C double bonds are cycloalkenes and those with C≡C triple bonds are cycloalkynes. Figure 8.4 shows examples of each of these cyclic hydrocarbon groups.

## Representing organic molecules

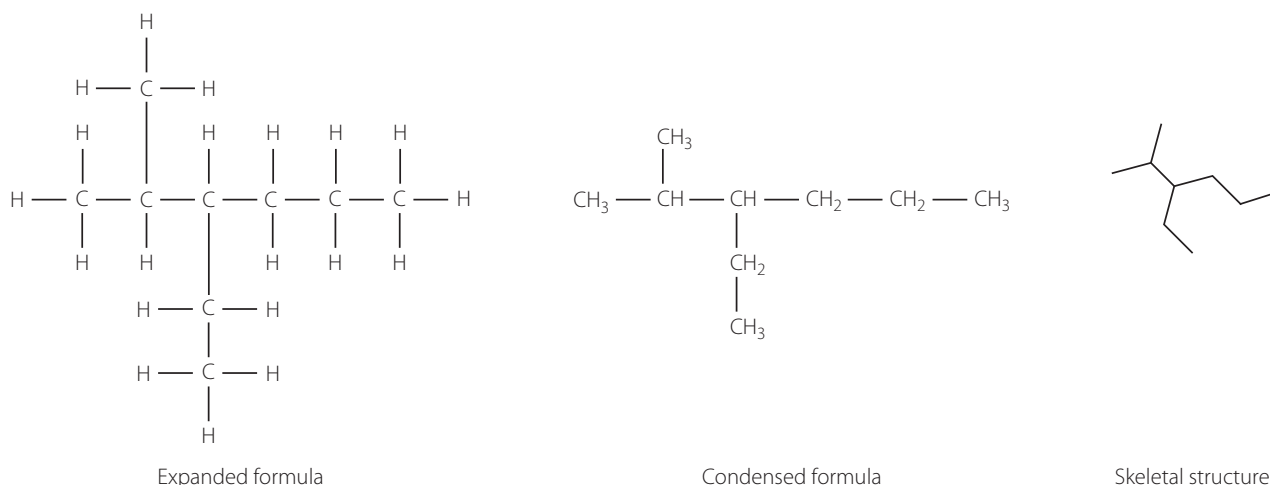
Organic molecules can be represented in a number of different ways, each giving different information. A **molecular formula** such as C<sub>3</sub>H<sub>8</sub> gives information on the number of atoms, but nothing about the arrangement of those atoms.

Usually, **structural formulae** are used to represent organic molecules as the arrangement of atoms can vary greatly within molecules with the same molecular formula. Figure 8.5 shows the same molecule represented in expanded, condensed and skeletal structures.

The **expanded formula** shows each atom arranged in relation to the others. The **condensed formula** is more commonly used and condenses alkyl groups such as —CH<sub>2</sub> and —CH<sub>3</sub>, while still showing the overall arrangement of atoms in the molecule. The **skeletal structure** is more basic, showing only a representation of the carbon chain arrangement, but none of the atom detail.



**FIGURE 8.4** Examples of cyclic hydrocarbons showing the structural formula



**FIGURE 8.5** Expanded formula, condensed formula and skeletal structure representations of organic molecules

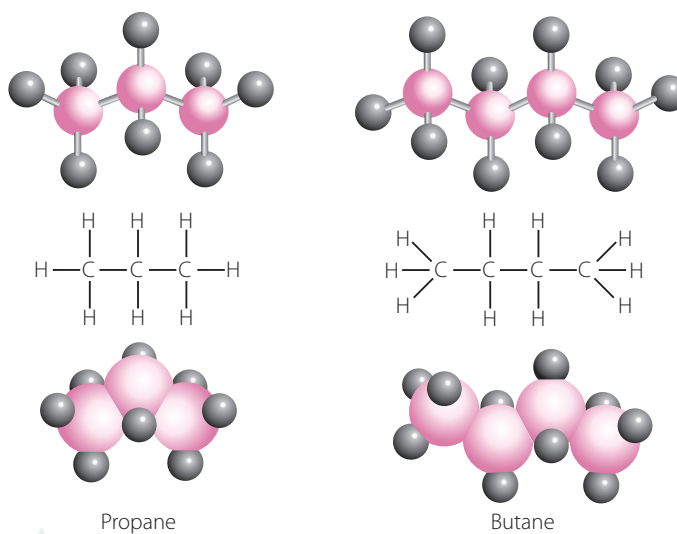
- More than 90 per cent of known compounds are organic compounds, giving the branch of chemistry called organic chemistry.
- Carbon readily bonds to other atoms and can form four bonds with its four valence electrons in single, double or triple forms.
- Hydrocarbons are made of only hydrogen and carbon and can be aromatic – containing a benzene ring – or aliphatic; all other hydrocarbons are in either chain or ring form.
- Alkanes have single bonds between carbon atoms and are saturated compounds.
- Alkenes have a double bond between two carbon atoms, and alkynes have a triple bond between two carbon atoms. These are both unsaturated compounds.
- Cyclic hydrocarbons, or alicyclic compounds, are ring structures commonly containing five or six carbons.

- 1 Describe how the valence electrons of carbon are involved in bonding in organic compounds.
- 2 Describe the differences between:
  - a aromatic and aliphatic compounds
  - b saturated and unsaturated compounds
  - c alkanes, alkenes and alkynes.
- 3 Explain the reason ball and stick models are used over space-filling models when drawing organic molecules.
- 4 Use diagrams to contrast the geometrical arrangements of the bonds around a carbon atom.
- 5 Use diagrams to explain the difference between representing organic molecules in expanded formula, condensed formula and skeletal structure.

## 8.2 Alkanes

The alkane family is very important because among its members are the fuels that supply us with energy every day. For many Australians, we use alkanes to run our cars, supply us with hot water, heat our homes and cook our food. Alkanes also supply us with the raw materials to make many other substances, including plastics.

The simplest alkane is methane ( $\text{CH}_4$ ). Next are ethane ( $\text{C}_2\text{H}_6$ ), propane ( $\text{C}_3\text{H}_8$ ), and butane ( $\text{C}_4\text{H}_{10}$ ). Figure 8.6 shows models and structural formulae for propane and butane.



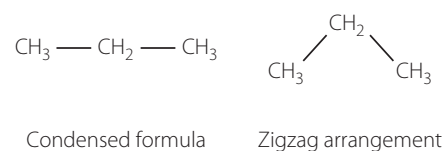
**FIGURE 8.6** Models and structural formulae for propane and butane

The first ten alkanes are listed in Table 8.2. These are called straight-chain alkanes because the carbon atoms are joined in one continuous string. The chain is not really straight but more like a zigzag because of the way carbon bonds are arranged tetrahedrally. Alkanes are saturated compounds, containing no multiple carbon-carbon bonds. Figure 8.7 shows an alkane in condensed formula and in the zigzag arrangement.

**TABLE 8.2** First ten members of the alkane family

NAME	FORMULA
Methane	CH <sub>4</sub>
Ethane	C <sub>2</sub> H <sub>6</sub>
Propane	C <sub>3</sub> H <sub>8</sub>
Butane	C <sub>4</sub> H <sub>10</sub>
Pentane	C <sub>5</sub> H <sub>12</sub>
Hexane	C <sub>6</sub> H <sub>14</sub>
Heptane	C <sub>7</sub> H <sub>16</sub>
Octane	C <sub>8</sub> H <sub>18</sub>
Nonane	C <sub>9</sub> H <sub>20</sub>
Decane	C <sub>10</sub> H <sub>22</sub>

The alkanes are known as a homologous series. A homologous series is a group of compounds with the same general formula. Each successive member of the series is formed by replacing one H with a C and then adding three more hydrogens. This pattern follows for all straight-chain alkanes, so the general molecular formula for alkanes can be expressed as C<sub>n</sub>H<sub>2n+2</sub> where *n* is a whole number.

**FIGURE 8.7** Straight-chain and zigzag arrangement of an alkane molecule

## Naming alkanes

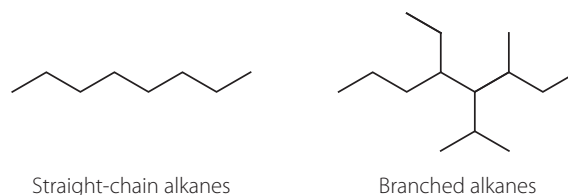
Naming of hydrocarbons is governed by IUPAC – the International Union of Pure and Applied Chemistry. There is a set of guidelines used the world over that determines a single scientifically accepted name for any organic compound. This ensures consistency between scientists no matter what language they speak or in what country they are working.

The name of a carbon compound consists of a stem, which gives the length of the carbon chain, and an ending, which denotes the family of hydrocarbons the compound belongs to. All compounds that are in the alkane family have names ending in -ane. The stems of the first ten members of the series are: meth –C<sub>1</sub>, eth –C<sub>2</sub>, prop –C<sub>3</sub>, but –C<sub>4</sub>, pent –C<sub>5</sub>, hex –C<sub>6</sub>, hept –C<sub>7</sub>, oct –C<sub>8</sub>, non –C<sub>9</sub>, dec –C<sub>10</sub>. The combination of stem and ending -ane leads to the names given in Table 8.2.

The alkanes considered so far have been straight-chain alkanes. These are compounds in which all of the carbon atoms are in one continuous chain. However, many carbon compounds contain branched chains. The skeletal structure of a straight-chain and a branched alkane is shown in Figure 8.8.

The rules for naming branched alkanes are as follows.

- 1 The end of the name indicates to which hydrocarbon family the compound belongs. Alkanes always end in -ane.
- 2 Determine the longest continuous carbon chain and use the name of the corresponding alkane. This chain may not necessarily be drawn in a linear manner. This is the **main chain** and represents the parent structure. For example, if the longest chain had six carbon atoms, the parent structure would be hexane.

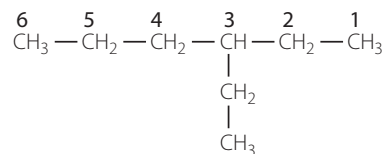
**FIGURE 8.8** Straight-chain and branched alkanes

- 3 Other atoms or groups of atoms attached to the main (parent) chain are **substituents** and form 'branches'. If the substituent is a carbon group, then it is called an alkyl group. The alkyl group is named according to the number of carbon atoms and given the ending -yl. For example, a substituent group  $\text{CH}_3\text{CH}_2-$  would be called ethyl, while the  $\text{CH}_3-$  would be called methyl.

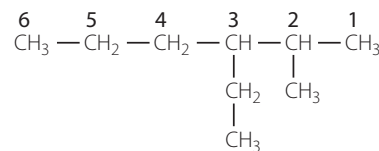
Number the carbons in the main (parent) chain so the branch or branches have the lowest possible number/s.

The position at which the group is attached to the main (parent) chain is specified by the number of the carbon to which it is attached. The number is separated by a hyphen.

In the first example to the right, the branch is 3-ethyl and the compound is 3-ethylhexane. **Note:** The alkane name is written as one word.



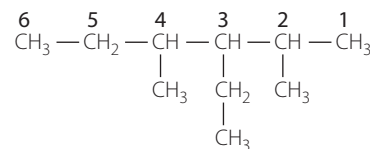
- 4 List the names of the substituents in alphabetical order. In the second example to the right, there are two branches: 3-ethyl and 2-methyl. Words and numbers are separated by a hyphen.



The name of this compound is 3-ethyl-2-methylhexane.

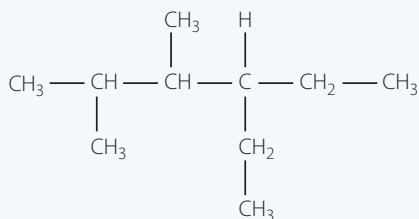
Where there is more than one substituent of the same type, use the prefixes di- (two), tri- (three), tetra- (four), penta- (five), etc. Separate numbers by a comma.

In the third example to the right, the compound contains two methyl groups so 'dimethyl' will be part of its name, which is 3-ethyl-2,4-dimethylhexane.



### WORKED EXAMPLE 8.1

Name the following alkane.

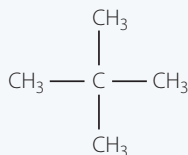


ANSWERS	LOGIC
Name ends with 'hexane'	<ul style="list-style-type: none"> <li>Determine the longest continuous chain to get base name – 6 carbons.</li> </ul>
Name includes (in alphabetical order): 4-ethyl 2,3-dimethyl	<ul style="list-style-type: none"> <li>List substituents and number of each.</li> <li>Arrange the substituents in alphabetical order.</li> <li>Remember to ignore the di- of the 2,3-dimethyl when arranging alphabetically.</li> </ul>
4-ethyl-2,3-dimethylhexane	<ul style="list-style-type: none"> <li>Write the full final name.</li> </ul>

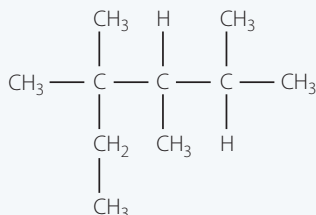
### TRY THESE YOURSELF

Name the following alkanes.

1



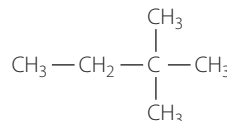
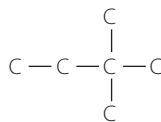
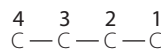
2



## Drawing alkanes

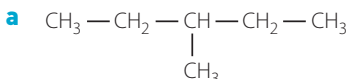
To draw the structure when given a systematic name:

- 1 Use the main name to draw the longest carbon chain and number the carbon chain, starting from 1 at an end of the chain (it doesn't matter which end). For example, in 2,2-dimethyl butane, the main chain is butane and the carbon atoms are numbered from 1 to 4.
- 2 Identify the substituents that form the branches and to which carbon atom they are attached. For example, in 2,2-dimethylbutane, there are two methyl groups, both attached to carbon number 2.
- 3 Add the substituent group(s) to the parent chain.
- 4 Add hydrogen atoms to complete the structure. Check that each carbon atom has four bonds.



- Alkanes have general formula  $\text{C}_n\text{H}_{2n+2}$ .
- The prefixes for the number of carbons in the main (parent) chain of a hydrocarbon are meth- (1), eth- (2), pro- (3), but- (4), pent- (5), hex- (6), hept- (7), oct- (8), non- (9), dec- (10).
- Alkanes can be straight chain or branched.
- Naming alkanes has a specific set of rules involving numbering the main (parent) chain and using those numbers to identify substituents (side chains).
- Alkyl substituents are named according to the number of carbon atoms: methyl (1), ethyl (2), propyl (3), etc.
- Substituents are named in alphabetical order, ignoring any prefixes.
- Alkanes are drawn by using the numbers of the substituents in the name to position them on the main (parent) chain.

- 1 Give the general formula for alkanes.
- 2 List the prefixes given for the stems of hydrocarbon names with 1–10 carbons.
- 3 Give the name and formula of the first ten straight-chain alkanes.
- 4 Name the following alkanes.

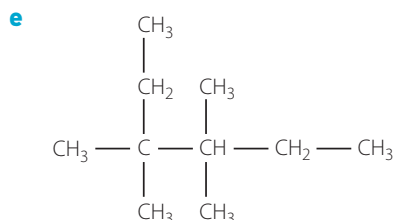
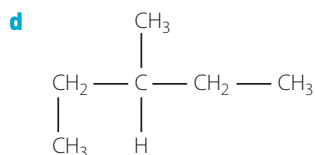
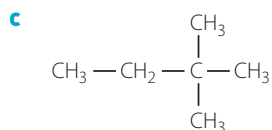
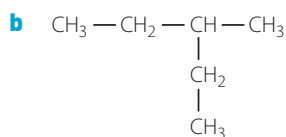


### CHECK YOUR UNDERSTANDING

8.2

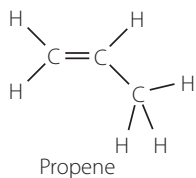
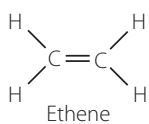






- 5** Draw the following alkanes.
- 2-methylpentane
  - 2,3-dimethylbutane
  - 3-ethyl-3-methylhexane
  - 2,2,3-trimethylpentane
  - 3-ethyl-2,3-dimethyloctane
- 6** By drawing the alkane, explain why the names below are incorrect, then write the correct name of the molecule.
- 4,4-dimethylhexane
  - 12-dimethylbutane

## 8.3 Alkenes



**FIGURE 8.9** Ethene and propene

The alkene family contains hydrocarbons in which one pair of carbon atoms is joined by a double bond and all the other carbon atoms are joined by single bonds. All compounds that are in the alkene family have names ending in *-ene*. The simplest alkene is ethene ( $\text{C}_2\text{H}_4$ ) and the next member is propene ( $\text{C}_3\text{H}_6$ ). These structures are shown in Figure 8.9.

Since alkenes contain double bonds between carbon atoms they are unsaturated hydrocarbons.

Alkenes have a general formula  $\text{C}_n\text{H}_{2n}$ . As with alkanes, each successive member of the series is formed by adding  $\text{CH}_2$  to the formula of the previous member.

## Naming alkenes

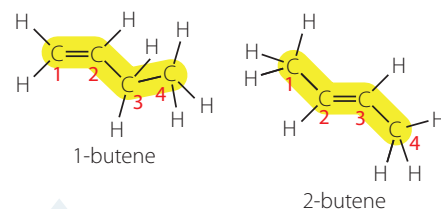
The process of naming alkenes has a lot of similarities to naming alkanes but with one major difference. The double bond in the alkene molecule can occupy a number of different positions. While this does not change the molecular formula of the compound, it does change the structural formula, which shows the position of the double bond. This can be seen in Figure 8.10.

When naming alkenes, the location of the double bond needs to be included. Alkenes are named according to the following rules.

- 1 Take the usual stem name (such as eth- or but-), which indicates the number of carbon atoms in the chain, and add the ending -ene.
- 2 Determine the location of the double bond by numbering the carbon atoms from the end of the chain closest to the double bond, as shown in Figure 8.10.
- 3 Show the location of the double bond by putting in front of the name the number of the carbon at which the double bond starts, followed by a hyphen. For example, in Figure 8.10 in 1-butene, the double bond is between carbons 1 and 2. In 2-butene, the double bond is between carbons 2 and 3. Note that for ethene and propene no number is required since there is only one possible position of the double bond.

To name branched alkenes, add the following rules to those for naming branched alkanes.

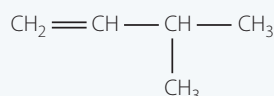
- 4 When naming alkenes the longest continuous carbon chain containing the carbon-carbon double bond becomes the main (parent) chain. This may not be the longest carbon chain in the molecule. The name corresponding to the alkane stem with the ending -ene forms the main name.
- 5 Branched alkenes are named in a similar way to branched alkanes, except the lowest number is assigned to the double bond and not the substituent group.



**FIGURE 8.10** The different possible positions for the double bond in a butene molecule

### WORKED EXAMPLE 8.2

Name the following alkene.

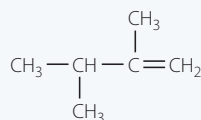


ANSWER	LOGIC
Name ends with '1-butene'	▪ Determine the longest continuous chain and position of double bond to get base name – 4 carbons, double bond on first carbon.
Name includes: 3-methyl	▪ List substituents and number of each.
3-methyl-1-butene	▪ Arrange substituents in alphabetical order ignoring any di-, tri-, etc. prefixes and write final name.

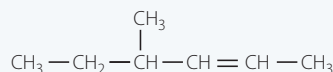
### TRY THESE YOURSELF

Name the following alkenes.

1



2



## Drawing alkenes

To draw the structure when given a systematic name:

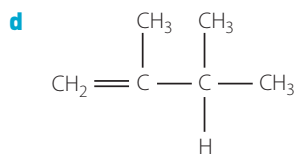
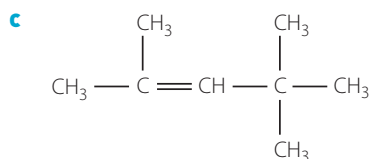
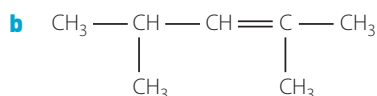
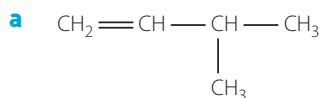
- 1 Use the main name to draw the longest carbon chain and number the carbons, starting from 1 at any end of the chain.
- 2 Draw a double bond according to the number in the main name. For example, for 2-butene, draw the double bond between the second and third carbons.
- 3 Identify the substituents that form the branches and to which carbon they are attached. Add to the main chain.
- 4 Add hydrogen atoms to complete the structure, checking that each carbon has four bonds.

- Alkenes contain a double bond between two carbon atoms and have a name ending in -ene.
- Alkenes have general formula  $C_nH_{2n}$ .
- Alkenes are named in a similar manner to alkanes, with the position of the double bond indicated by a number in the name.
- Alkenes are drawn by inserting a double bond between carbons as indicated by the number in the name.

### CHECK YOUR UNDERSTANDING

8.3

- 1 Give the general formula for alkenes.
- 2 Identify the main difference between the alkane and alkene families of molecules.
- 3 Name the following alkenes.



- 4 Draw the following alkenes.
  - a 2-methyl-2-pentene
  - b 3,3-dimethyl-1-butene
  - c 2,3-dimethyl-2-hexene
  - d 2,3-dimethyl-3-ethyl-1-heptene
- 5 Draw the structure of 3-methyl-3-butene and explain why it is not the correct name. Write the correct name of this molecule.

## 8.4 Alkynes

Alkynes are a family of hydrocarbons containing at least one triple bond between a pair of carbon atoms. The alkynes, like alkenes, are unsaturated hydrocarbons.

The simplest member, ethyne ( $C_2H_2$ ) is a linear molecule, as shown in Figure 8.2 (p. 240). Ethyne is commonly known as acetylene and is widely used in oxyacetylene torches for cutting and welding, as seen in Figure 8.11.

Alkynes have the general molecular formula  $C_nH_{2n-2}$ . Similar to both alkanes and alkenes, each successive member of the series is formed by adding  $CH_2$  to the formula of the previous member.

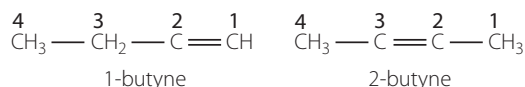


**FIGURE 8.11** Oxyacetylene torches are widely used for cutting and welding metals.

### Naming and drawing alkynes

Naming alkynes follows the same rules as alkenes. The position of the triple bond is indicated with a number, and when numbering carbons, the triple bond must have the smallest number possible.

- 1 Add the ending *-yne* to the usual stem name (for example, *eth-* and *prop-*), which indicates the number of carbon atoms in the chain.
- 2 Determine the location of the triple bond by numbering the carbon atoms from the end of the chain closest to the triple bond.
- 3 Show the location of the triple bond by putting in front of the name the number of the carbon at which the triple bond starts followed by a hyphen. Numbers are not used for ethyne and propyne since they have no other options but to have the triple bond on carbon 1.



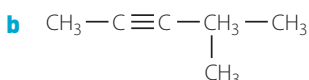
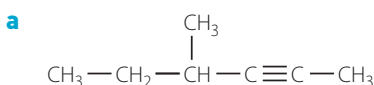
The first compound shown to the right is 1-butyne and the second is 2-butyne. Drawing alkynes follows the same rules as alkenes.

- Alkynes have a triple bond between two carbons in the main (parent) chain and are unsaturated hydrocarbons.
- Alkynes have general formula  $C_nH_{2n-2}$ .
- Alkynes are named using the same rules as alkanes and alkenes, with the position of the triple bond indicated by a number.



Properties and bonding in carbon

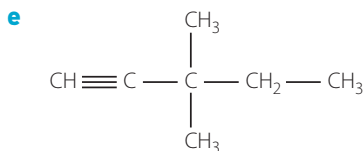
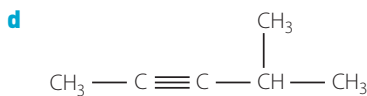
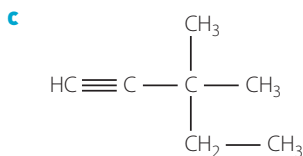
- 1 Give the general formula for alkynes.
- 2 Name the following alkynes.



CHECK YOUR UNDERSTANDING

8.4





- 3** Draw the following alkynes.
- 3-heptyne
  - 4,6-dimethyl-2-heptyne
  - 4,4-dimethyl-2-pentyne
- 4** 2-ethyl-2-methyl-3-butyne is incorrectly named. Draw the molecule to help explain why and give its correct name.

## 8.5 Halogenated organic compounds

Halogenated organic compounds include any organic compound that contains one or more halogen atoms (bromine, chlorine, fluorine or iodine) attached to one of the carbon atoms in the molecule. A molecule can have different halogen atoms within one molecule; for example, it may contain both bromine and chlorine atoms.

**Haloalkanes** are commonly occurring organic molecules that have a wide variety of uses. In the past they have been used as refrigerants, firefighting agents and to make various polymers. Unfortunately, many of these substances were released into the atmosphere during use, or through production or the disposal of appliances and polymers. Their chemical reactions in the upper atmosphere have contributed to the hole in the ozone layer.

Halogen atoms such as fluorine, chlorine, bromine and iodine can be side chains on hydrocarbon molecules.

To name hydrocarbons with halogen atoms attached to carbons on the main (parent) chain:

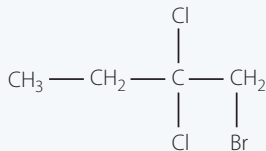
- 1 Name the main (parent) chain as normal, including the position of any double or triple bonds. Where double and triple bonds exist in the chain, they must be given the lowest number when numbering the chain.
- 2 Alkyl side chains are identified and named as normal.
- 3 Any halogen atoms are identified with the number of the carbon they are attached to. Their name is given as follows: fluorine (-fluoro), chlorine (-chloro), bromine (-bromo), iodine (-iodo). For example, a chlorine on the second carbon is 2-chloro. If bromines are found on the second and third carbon, then it is named 2,3-dibromo.

When allocating numbers to the halogens, the overall combination of numbers must be as low as possible. For example, 2,2-dibromo-3-chloro is a lower combination than 3,3-dibromo-2-chloro.

- 4 The halogen branches are put into alphabetical order with any other branches, remembering to exclude any prefixes such as di-, tri-, tetra-, etc. and so on.

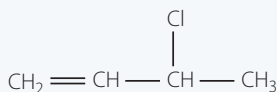
### WORKED EXAMPLE 8.3

1 Name the following haloalkane.



ANSWER	LOGIC
1 Name ends with 'butane'	<ul style="list-style-type: none"> <li>Determine the longest continuous chain and position of any double or triple bonds to get base name – 4 carbons.</li> </ul>
Name includes: 1-bromo 2,2-dichloro	<ul style="list-style-type: none"> <li>List substituents and number of each.</li> </ul>
1-bromo-2,2-dichlorobutane	<ul style="list-style-type: none"> <li>Arrange substituents in alphabetical order ignoring any prefixes such as di-, tri-, and so on and write final name.</li> </ul>

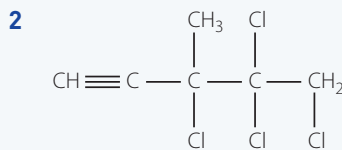
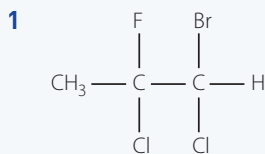
2 Name the following haloalkene.



ANSWER	LOGIC
2 Name ends with '1-butene'	<ul style="list-style-type: none"> <li>Determine the longest continuous chain and position of any double or triple bonds to get base name – 4 carbons.</li> <li>Remember any double bond must have the lowest number so will be 1-butene.</li> </ul>
Name includes: 3-chloro	<ul style="list-style-type: none"> <li>List substituents and number of each.</li> </ul>
3-chloro-1-butene	<ul style="list-style-type: none"> <li>Arrange substituents in alphabetical order write final name.</li> </ul>

#### TRY THESE YOURSELF

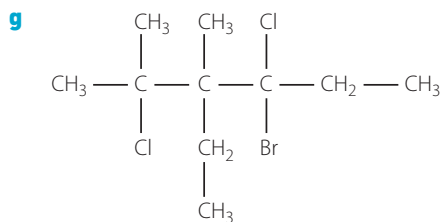
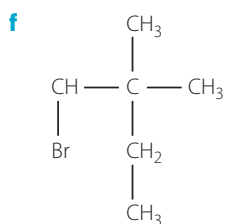
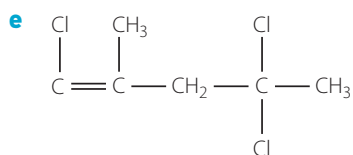
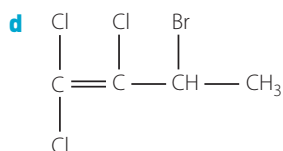
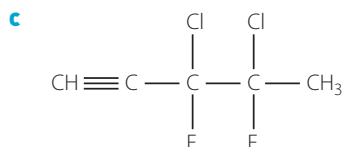
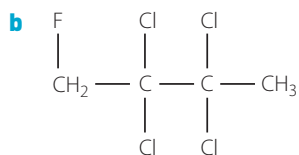
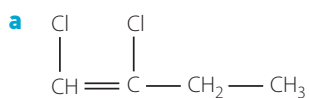
Name the following haloalkane and haloalkyne.



- Haloalkanes are hydrocarbons that contain halogen atoms like fluorine, chlorine and bromine.
- Halogens that are substituents in a haloalkane are named as -chloro, -fluoro, -bromo and -iodo, with their position indicated by a number.



1 Name the following halogenated organic compounds.



2 Draw the following halogenated organic compounds.

- 1,2,3-tribromo-2,3-dichlorobutane
- 3,4-dibromo-1,3-difluoro-1-heptene
- 11-ichloro-1,-difluorohexane

## INVESTIGATION 8.1

### Modelling hydrocarbon structures

#### AIM

To investigate the structures of hydrocarbons through modelling.

#### MATERIALS

- Organic model kits (if no kits are available, use modelling clay in various colours to represent carbon, hydrogen and various halogen atoms, toothpicks to represent bonds)
- Digital camera

#### WHAT ARE THE RISKS IN DOING THIS INVESTIGATION?

Possible risk of slipping on model kit components if they are on the floor

#### HOW CAN YOU MANAGE THESE RISKS TO STAY SAFE?

Keep all components within the containers provided if not being used.



What other risks are associated with your investigation? How can you manage these?

#### METHOD

- Use the model kits to make the first five alkane, alkene and alkyne molecules.
- Take photos of each model and create a multimedia presentation showing each molecule with its correct name.

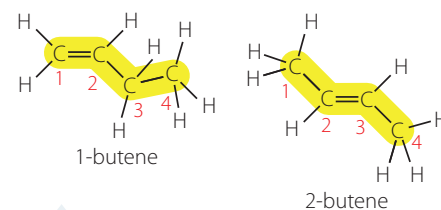
#### DISCUSSION

- Compare the shapes of the first five alkanes.
- Explain the shape of the main (parent) chain seen.
- Why could 'straight chain' be seen as a misleading description of the alkanes?
- Describe the effect on the molecule shape of including a double or triple bond in the main (parent) chain.
- Using 5 carbon and 12 hydrogen atoms, construct as many different molecules as you can. You can include branches in your structures.
- Compare the number of molecules you made with other groups until you are confident you have found them all.
- Correctly name each of the molecules you have constructed.
- Is it possible to make two different molecules with the same name? Explain your answer.
- With a partner, each person construct three molecules: one alkane, one alkene and one alkyne each of which must contain side chains or halogens or both. Give your three molecules to your partner to name, while you name the molecules your partner constructed.

## 8.6 Isomers

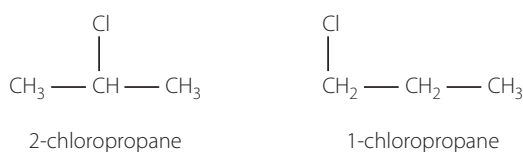
Compounds that have the same molecular formula but different structural formula are called **structural isomers**. In hydrocarbons, isomers can occur through changing the position of double or triple bonds, or different placement of substituents (**positional isomers**). **Chain isomers** involve rearrangement of the carbon skeleton.

Figure 8.12 shows two isomers of butene that you looked at earlier.



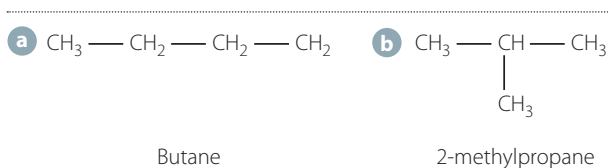
**FIGURE 8.12** The different position of the double bond means these two molecules are positional isomers.

Figure 8.13 shows a position isomer involving a chlorine atom located on different carbons, giving 2-chloropropane (left) and 1-chloropropane (right). This is a position isomer since the basic organic molecule is the same, but the substituents are placed on different carbon atoms.



**FIGURE 8.13** Example of a position isomer

Isomers also occur due to rearrangement of the chain, as seen in Figure 8.14. Butane ( $\text{C}_4\text{H}_{10}$ ) is a straight-chain molecule. 2-methylpropane is also  $\text{C}_4\text{H}_{10}$ , but in a different configuration. Butane and 2-methylpropane are structural isomers. This is an example of chain isomerism.



**FIGURE 8.14** Chain isomers: **a** butane and **b** 2-methylpropane



Isomers

## 8.7

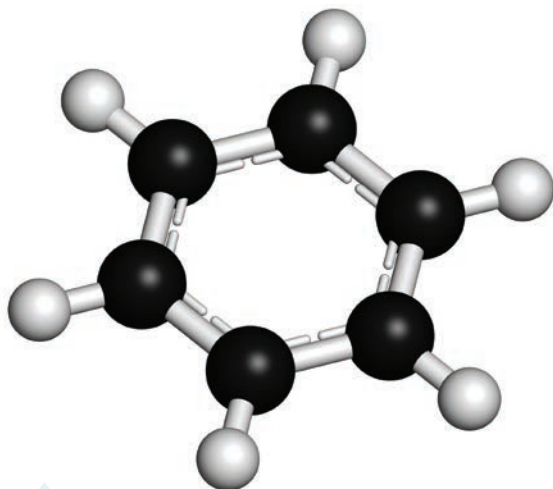
# Benzene

The group known as aromatic compounds originally got their name because many of them have a strong smell (aroma). They all contain a ring or groups of rings of carbon atoms linked together in a special way such that they have delocalised electrons. Delocalised electrons are electrons that are

not contained within bonds but are free to move about a structure or material. Since they are free to move, they change the properties of benzene significantly from other organic molecules that do not contain delocalised electrons.

Many of these compounds were originally derived from plant oils. Today, the source of many aromatic hydrocarbons is coal tar.

The simplest, and also the parent compound of this family, is benzene. It is a colourless liquid with molecular formula  $\text{C}_6\text{H}_6$  so it is an unsaturated molecule. It is a flat, six-sided ring, with all bond angles being  $120^\circ$ . Figure 8.15 shows a model of benzene.



**FIGURE 8.15** A model of benzene

On the basis of this representation, it was thought that benzene contained alternating single and double bonds so should undergo reactions similar to those of alkanes and alkenes. However, this rarely happens. The reactions of benzene are completely different to those of other double-bonded hydrocarbons.

Further investigation of the benzene ring found that all the carbon-carbon bonds were the same length, which is somewhere between the length of a single bond and a double bond. This can be explained if the electrons of the double bond are spread out around the ring of carbon atoms making a cloud of delocalised electrons above and below the ring, as shown in Figure 8.16. This is similar to the delocalisation of electrons found in the structure of metals.

In chemical structures, the benzene ring is usually represented in either of the two forms shown in Figure 8.17.

The cyclic delocalisation of electrons in the benzene molecule makes it extremely stable. Benzene tends to undergo reactions in which the stable ring is preserved because reactions that disrupt the bonding due to the delocalised electrons are less favourable and will only occur at higher temperatures and under more vigorous conditions.

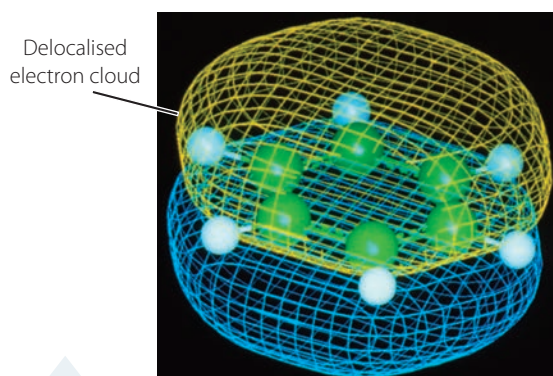


FIGURE 8.16 Bonding in benzene

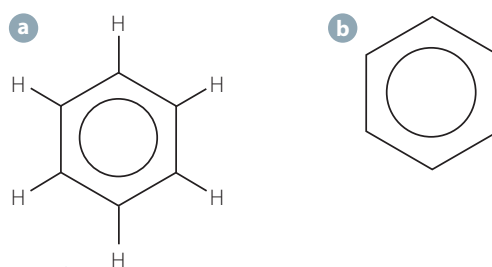
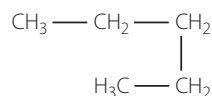
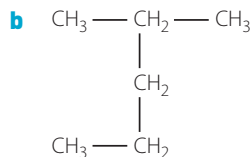
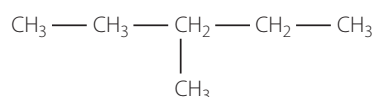
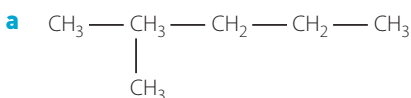


FIGURE 8.17 Different ways of drawing benzene

- Structural isomers have the same molecular formula but different structural formula.
- Isomers can occur through different positions of the double or triple bonds in alkanes and alkynes, or through different placement of substituents – either alkyl chains or halogens.
- Benzene is a 6-carbon ring with a cloud of delocalised electrons above and below the ring.
- Benzene is the parent molecule for a group of compounds, the aromatic hydrocarbons.
- Benzene is extremely stable and has different physical and chemical properties than other hydrocarbons.

- 1 Explain, using butane as an example, what is meant by the term 'structural isomer'.
- 2 Which of the following pairs represent structural isomers?



- 3 Draw and name all possible isomers of pentane and butene.
- 4 What is the main characteristic of aromatic compounds?
- 5 Write the formula and draw the structure of the parent member of the aromatic family.
- 6 Explain why benzene is extremely stable.
- 7 Draw the structure of the compound formed if one of the hydrogen atoms on the benzene ring was substituted with a methyl group.

CHECK YOUR  
UNDERSTANDING

8.6

8.7

## 8.8 Properties of alkanes

Alkanes are covalent molecular substances so will have similar physical properties to other covalent molecules. Carbon and hydrogen have similar electronegativity and most hydrocarbon molecules are relatively symmetrical, making hydrocarbons non-polar. Alkenes and alkynes have a similar structure to alkanes, and so share the same physical properties.

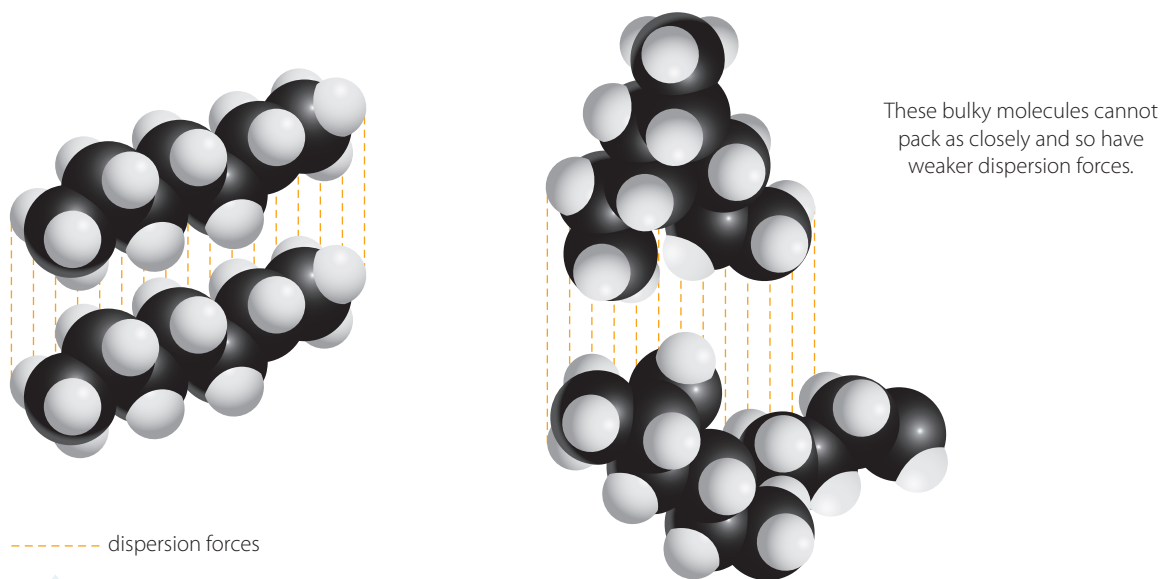
Alkanes have relatively low melting and boiling points since dispersion forces are the only type of intermolecular force that forms between molecules.

As the size of the molecule increases, more atoms are present, increasing the number of electrons in the molecule. Thus the strength of the overall dispersion forces between molecules increases. Larger molecules require more energy to overcome the dispersion forces between molecules and so have higher melting and boiling points. As a consequence, the shorter chain alkanes like ethane and propane are gases at room temperature. Longer chain alkanes like octane (main component of petrol) and oils are liquids, and very long chain alkanes like waxes and tar will be solids.

The shape of the hydrocarbon also plays a role in the melting and boiling points, as seen in Figure 8.18. Linear molecules pack closely together and allow many dispersion forces to form, thus creating a greater attraction between molecules. Bulky molecules do not pack neatly together, so less overall dispersion forces form, changing the melting and boiling points.



Trends in alkanes



**FIGURE 8.18** Factors that affect attraction between hydrocarbon molecules: size and shape

Alkanes do not conduct electricity since they are non-polar molecules. They have no dipole charges or ionic charges that would allow them to conduct electricity.

Alkanes are insoluble in water and other polar solvents. They cannot form bonds with polar molecules and so will not dissolve in them. Alkanes will form dispersion forces with other non-polar molecules, so will be soluble in non-polar solvents such as hexane.

## INVESTIGATION 8.2

### Properties of compounds in a homologous series



#### AIM

To analyse data and investigate trends in the melting and boiling points of alkanes.

#### METHOD

- 1 Use a graphing program with the data in the table below to graph the melting and boiling points of the alkanes provided against the molecular weight.

NAME	MOLECULAR WEIGHT	MELTING POINT (°C)	BOILING POINT (°C)	DENSITY OF LIQUID (g/mL AT 0°C)
Methane	16.0	-182	-164	Gas
Ethane	30.1	-183	-88	Gas
Propane	44.1	-190	-42	Gas
Butane	58.1	-138	0	Gas
Pentane				0.626
Hexane	86.2	-95	69	0.659
Heptane	100.2	-90	98	0.684
Octane	114.2	-57	126	0.703
Nonane	128.3	-51	151	
Decane	142.3	-30	174	0.730

- 2 Use your graph to estimate the molecular weight, melting point and boiling point of pentane. Research the correct values and comment on the accuracy of your answers. Propose reasons for any difference between your answer and the accepted values.
- 3 Devise a method for determining the density of nonane given the values provided in the table. Research the correct values and comment on the accuracy of your answer.

#### DISCUSSION

- 1 In terms of intermolecular bonding, explain why the melting and boiling points of the alkanes increase with increasing molecular weight.
- 2 Propose a reason the density of the liquid alkanes increases with molecular weight.

### Uses of alkanes and alkenes

The main use of alkanes can be seen in the examples below.

- Methane is the main component of natural gas.
- Propane is also known as LPG (liquid petroleum gas).
- Pentane is used as an industrial solvent.
- Octane is the main constituent of automobile fuel.
- Nonane and decane are both used in petrol as additives.



The longer chain molecules are fuel oil and mineral oil and these are used as lubricants. Other heavier molecules ( $C_{16}$  to  $C_{24}$ ) are the basis of petroleum jelly, greases, paraffin wax and asphalt.

The low molecular mass alkanes are the starting materials for many organic chemistry-based industries, such as paint and plastics manufacture.

The main use of alkenes is as the basis of the petrochemical industry – especially those with low molecular mass. They are used as the starting materials in the syntheses of alcohols, plastics, lacquers, detergents and fuels.

Ethene is the most important organic **feedstock** in the chemical industry. A feedstock is a chemical or substance that is used to manufacture useful materials and chemicals. Ethene is produced from natural gas and crude oil. It is used as feedstock for many chemical products such as polyethylene, vinyl chloride, styrene, ethanol, acetaldehyde and many more. It is also used for the artificial ripening of fruits, as a general anaesthetic, and to generate an ethylene-oxygen flame.

Propene, the second most important feedstock for organic products, is mainly used for the production of polypropylene and various oxidation products such as butanol, acrylic acid, acrolein, acrylic acid ester, glycerol, allyl chloride and epichlorohydrin.



Check your understanding

- Hydrocarbons, including alkanes, alkenes and alkynes, are largely non-polar covalent molecules that can be used to explain their properties.
- Hydrocarbons, including alkanes, alkenes and alkynes, have relatively low melting and boiling points due to the formation of weak dispersion forces between molecules.
- The melting and boiling points of hydrocarbons increase with molecule size due to increased dispersion forces that form between molecules.
- Hydrocarbons, including alkanes, do not conduct electricity since they have no dipole or ionic charges.
- Hydrocarbons are insoluble in polar solvents like water, but are soluble in non-polar solvents.
- Hydrocarbons have a wide variety of uses including fuels, feedstock for industrial processes, solvents, oils and greases.

## CHECK YOUR UNDERSTANDING

8.8

- 1 Identify three uses of alkanes.
- 2 Identify three uses of alkenes.
- 3 Explain what is meant by a 'feedstock'.
- 4 Explain why alkanes have relatively low melting and boiling points.
- 5 Explain why the first four alkenes are gases at room temperature, while the next in the homologous series are liquids.
- 6 Explain why alkanes:
  - a do not conduct electricity
  - b are insoluble in water but are soluble in non-polar solvents.
- 7 Explain why the physical properties of alkanes, alkenes and alkynes are very similar.
- 8 Sketch the general shape of a graph that plots molecular weight of an alkane against boiling point. Explain the shape of the graph you have drawn in terms of intermolecular forces.

# 8 CHAPTER SUMMARY

## IMPORTANT NEW TERMS

After studying this chapter you should know the meaning of the following terms:

aliphatic compound (p. 240)

alkane (p. 240)

alkene (p. 240)

alkyne (p. 240)

aromatic hydrocarbon (p. 240)

ball and stick model (p. 239)

benzene (p. 240)

chain isomer (p. 253)

condensed formula (p. 241)

cyclic hydrocarbon/alicyclic hydrocarbon (p. 241)

expanded formula (p. 241)

feedstock (p. 258)

haloalkane (p. 250)

hydrocarbon (p. 240)

main chain (p. 243)

molecular formula (p. 241)

organic chemistry (p. 239)

organic compound (p. 239)

positional isomer (p. 253)

saturated compound (p. 240)

skeletal structure (p. 241)

space-filling model (p. 239)

structural formula (p. 241)

structural isomer (p. 253)

substituent (p. 244)

unsaturated compound (p. 240)

## AFTER STUDYING THIS CHAPTER YOU SHOULD KNOW:

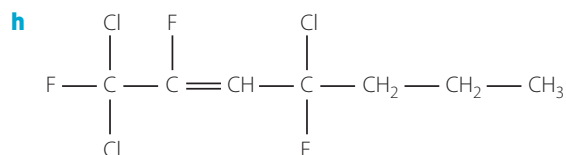
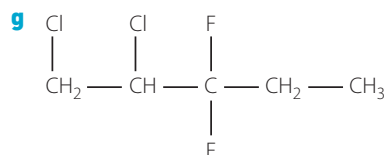
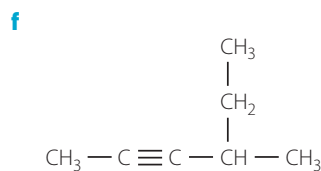
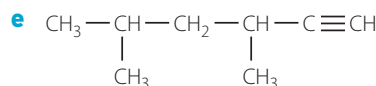
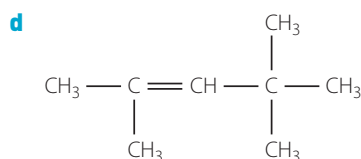
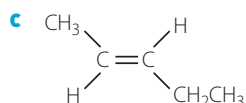
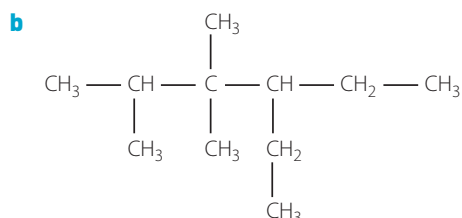
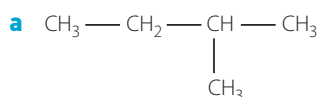
- the definitions for all terms in the important new terms list
- the IUPAC conventions for naming alkanes, alkenes, alkynes and haloalkanes (up to C<sub>8</sub>, including simple methyl and ethyl branched chains)
- the difference between alkanes, alkenes and alkynes
- the difference between saturated and unsaturated organic compounds
- the difference between chain and position isomers
- the key physical properties of alkanes and similar hydrocarbons
- the trends in boiling points and melting points within a homologous series (alkanes)
- the shapes of molecules when single, double or triple bonds form between carbon atoms.

## YOU SHOULD BE ABLE TO:

- name alkanes, alkenes and alkynes, up to C<sub>8</sub>, including simple methyl and ethyl branched chains
- name halogenated organic compounds
- draw structural and molecular formula for alkanes, alkenes and alkynes, up to C<sub>8</sub>, including simple methyl and ethyl branched chains
- identify and draw isomers of organic compounds
- draw the shape of molecules when single, double or triple bonds form between carbon atoms
- explain the physical properties of alkanes based on their molecular nature and in terms of intermolecular forces present.



- 1 Explain why carbon is the basis for so many compounds.
- 2 Draw electron dot diagrams to show how single, double and triple carbon-carbon bonds form.
- 3 Draw diagrams and name the geometrical shapes formed when carbon atoms have:
  - a four single bonds
  - b one double and two single bonds
  - c two double bonds
  - d one triple and one single bond.
- 4 Describe, with examples, the difference between saturated and unsaturated compounds.
- 5 Describe, with examples, the difference between aromatic and aliphatic compounds.
- 6 For each of the families of hydrocarbons (alkanes, alkenes and alkynes):
  - a give the general formula
  - b write the molecular and structural formula for the first five in the series; for the alkenes and alkynes, have the double and triple bond on the first carbon.
- 7 Name the following hydrocarbons.



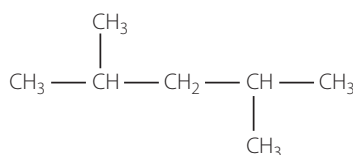
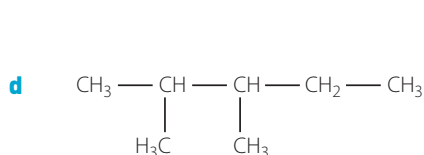
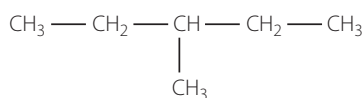
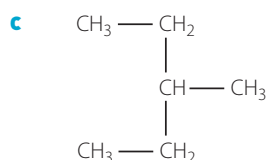
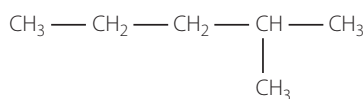
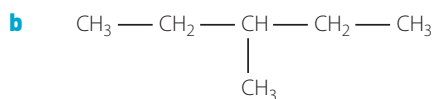
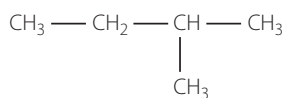
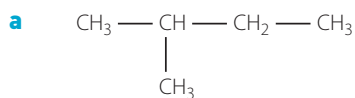
- 8 Draw structural formula for the following molecules.

- a 1,1-dichloroethane
- b 2,3-dimethylhexane
- c 2,2,6-trimethyl-3-octene
- d 2,3-dimethyl-3-ethyl-1-pentene
- e 4,5-dimethyl-2-hexyne
- f 3-ethyl-3-methyl-1-pentyne
- g 2,3,4-trichloro-2,3-difluoroheptane
- h 1,1,1-tribromo-2,2,2-trifluoroethane

- 9 Draw the following molecules, identify why they are named incorrectly and give the correct name.

- a 5-hexene
- b 2,2-dimethyl-4-heptene
- c 1,1-dichloro-2-bromo-3-butene

10 Explain whether the following pairs of structures represent isomers.



11 Draw and name all possible isomers of:

- pentane
- the alkene  $\text{C}_6\text{H}_{12}$  with the double bond staying between the first and second carbon atoms
- the alkene  $\text{C}_6\text{H}_{12}$  with the double bond staying between the second and third carbon atoms
- the alkyne  $\text{C}_5\text{H}_8$  with the triple bond staying between the first and second carbon atoms.

12 Using specific organic molecules, distinguish between chain and position isomers.

13 Pentane and 2,2-dimethylpropane are isomers.

- Identify the type of isomer that is formed here.
- Draw both molecules.
- Predict and explain which isomer will have a higher boiling point.

14 The table below shows the boiling points for some alkenes.

ALKENE	MOLECULAR WEIGHT	BOILING POINT ( $^{\circ}\text{C}$ )
Ethene		-104
Propene		-48
1-butene		-6
1-pentene		30
1-hexene		64
1-heptene		94
1-octene		121

- Calculate the molecular weight for each alkene and place into the table.
  - Graph the molecular weight against the boiling point.
  - Describe the trend shown on the graph.
  - Explain the trend in terms of intermolecular bonding.
- 15 Compound X has a boiling point of  $-6^{\circ}\text{C}$ . Compound Y has a boiling point of  $12^{\circ}\text{C}$ . Compound Z has a boiling point of  $-55^{\circ}\text{C}$ . All compounds are from the same homologous series.
- List the compounds in order of increasing molecular weight.
  - Explain your answer to part a.
- 16 A compound has a relatively low boiling point, but is able to conduct electricity and is soluble in water. Is it likely to be a hydrocarbon? Justify your answer.

# 9

## Functional group compounds

### INQUIRY QUESTION

How do we systematically name organic compounds?

### INQUIRY QUESTION

How can alcohols be produced and what are their properties?

### INQUIRY QUESTION

What are the properties of organic acids and bases?

#### Students:

investigate the nomenclature of organic chemicals, upto C<sub>8</sub>, using IUPAC conventions, including simple

methyl and ethyl branched chains, including: ACSCH12) ICT

- alcohols (primary, secondary and tertiary)
- aldehydes and ketones
- carboxylic acids
- amines and amides

explore and distinguish the different types of structural isomers, including saturated and unsaturated hydrocarbons, including: ACSCH03)

- functional group isomers

investigate the structural formulae, properties and functional group including:

- primary
- secondary
- tertiary alcohols ICT

explain the properties within and between the homologous series of alcohols with reference to the intermolecular and intramolecular bonding present ICT

conduct an investigation to compare the properties of organic chemical compounds within a homologous series, and explain these differences in terms of bonding ACSCH03)

investigate the structural formulae, properties and functional group including:

- primary, secondary and tertiary alcohols ICT
- aldehydes and ketones ACSCH12) ICT
- amines and amides

explain the properties within and between the homologous series of carboxylic acids amines and amides with reference to the intermolecular and intramolecular bonding present. ICT

Chemistry Stage 6 Syllabus © NSW Educational Standards Authority for and on behalf of the Crown in right of the State of New South Wales, 2017

Organic compounds are grouped into a series of 'families' of related compounds, which share key chemical properties. Most commonly, these properties arise from the presence of one or more particular groups of atoms, called **functional groups**. These 'families' are also known as a **homologous series**, a group of organic chemicals with the same functional group, varying only in the length of the carbon chain. A homologous series can be represented by a common general molecular formula.

This classification system is extremely useful because knowing the properties and reactivities of one member of a family allows you to predict the properties and reactivities of other family members. Similarly, finding ways to modify one member in a particular chemical reaction provides information on how to modify another member in the same way.



**FIGURE 9.1** Ethanol, with an alcohol functional group, is used as an additive in petrol.



Prior knowledge

## 9.1 Functional groups

A group or family of organic compounds has similar properties. Substances within a particular family contain a specific atom or group of atoms called a functional group. For example, compounds containing the  $\text{—OH}$  (**hydroxyl**) functional group are called **alcohols**. Alcohols have many common properties because the hydroxyl group is the most reactive part of the molecule and so compounds within this group will undergo similar types of reactions.

Table 9.1 lists important functional groups. In the general formula, the symbols R and R' are used to represent different alkyl groups. **R groups** can be a single hydrogen or carbon chain of any length, which can be straight chain, branched, cyclic or aromatic structures.

All the functional groups in the table are part of your course of study. This chapter and those following will focus on the structure, nomenclature, properties and reactions of alcohols, **aldehydes**, **ketones**, **carboxylic acids**, **amines**, **amides** and **esters**.

**TABLE 9.1** Functional groups

CLASS	SUFFIX	FUNCTIONAL GROUP	GENERAL STRUCTURE	EXAMPLE	NAME OF EXAMPLE
Haloalkane	—ane	Halogen $\text{—F}$ , $\text{—Cl}$ , $\text{—Br}$ , $\text{—I}$	$\text{R—X}$	$\begin{array}{c} \text{H} \quad \text{H} \\   \quad   \\ \text{H—C—C—Br} \\   \quad   \\ \text{H} \quad \text{H} \end{array}$	Bromoethane
Alcohol	—ol	$\text{—OH}$	$\text{R—OH}$	$\begin{array}{c} \text{H} \quad \text{H} \\   \quad   \\ \text{H—C—C—OH} \\   \quad   \\ \text{H} \quad \text{H} \end{array}$	Ethanol
Aldehyde	—al	$\begin{array}{c} \text{O} \\    \\ \text{—C—H} \end{array}$	$\begin{array}{c} \text{O} \\    \\ \text{R—C—H} \end{array}$	$\begin{array}{c} \text{H} \quad \text{H} \quad \text{O} \\   \quad   \quad    \\ \text{H—C—C—C—H} \\   \quad   \\ \text{H} \quad \text{H} \end{array}$	Propanal







CLASS	SUFFIX	FUNCTIONAL GROUP	GENERAL STRUCTURE	EXAMPLE	NAME OF EXAMPLE
Ketone	-one		$\text{R}-\overset{\text{O}}{\parallel}{\text{C}}-\text{R}'$		Propanone
Carboxylic acid	-oic acid		$\text{R}-\overset{\text{O}}{\parallel}{\text{C}}-\text{OH}$		Ethanoic acid
Ester	alkyl -oate		$\text{R}-\overset{\text{O}}{\parallel}{\text{C}}-\text{O}-\text{R}'$	$\text{CH}_3-\overset{\text{O}}{\parallel}{\text{C}}-\text{O}-\text{CH}_3$	Methyl ethanoate
Amine	-amine	$-\text{NH}_2$			Ethanamine
Amide	-amide		$\text{R}-\overset{\text{O}}{\parallel}{\text{C}}-\text{NH}_2$		Methanamide

## 9.2 Alcohols

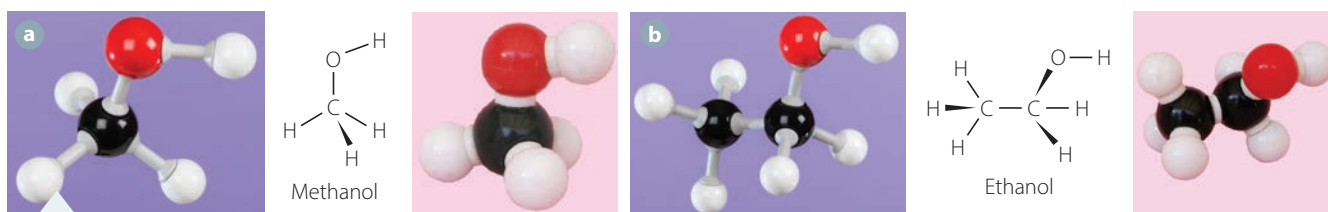
Ethanol, or ethyl alcohol, is the most commonly known member of the alcohol family. It is also one of the most widely used compounds of carbon. Its major uses are:

- in beverages, such as wine, beer and spirits
- as an additive to petrol or alternative fuels for motor vehicles
- as a solvent in many products, including medicines, antiseptics and household cleaners
- as a reactant and solvent in industry for the manufacture of many products, including plastics, adhesives, pharmaceuticals and perfumes.

However, ethanol is only one member of the family of organic compounds called alcohols. The alcohol functional group is the hydroxyl group  $-\text{OH}$ , and all alcohols have the general formula  $\text{R}-\text{OH}$ .

Alcohols have a general molecular formula of  $\text{C}_n\text{H}_{2n+1}\text{OH}$ . The simplest alcohol is  $\text{CH}_3\text{OH}$ , which is methanol or methyl alcohol. Ethanol, or ethyl alcohol, is  $\text{CH}_3\text{CH}_2\text{OH}$ .

Figure 9.2 shows ball and stick, structural and space-filling models for methanol and ethanol.



**FIGURE 9.2** Ball and stick, structural and space-filling models for **a** methanol and **b** ethanol

## Naming and drawing alcohols and their isomers

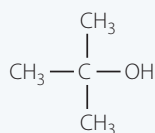
The name given to an alcohol clearly reflects its relationship to the alkane. It is simply a substitution of one H on an alkane by an —OH group.

Naming alcohols shares many of the rules of naming alkanes and other hydrocarbons. To name an alcohol:

- 1 identify the longest carbon chain, the parent or main chain and use the stems previously used for hydrocarbons (for example, if the parent chain has four carbons, then the stem is but-)
- 2 once the stem is identified, write the alkane name without the 'e' at the end, and replace with 'ol' (so butane becomes butanol, ethane becomes ethanol and hexane becomes hexanol)
- 3 similar to identifying the position of the double bond in alkenes, the position of the —OH group is identified by using a number in front of the main alcohol name (for example, if the hydroxyl group is on the second carbon of butanol, the name would be 2-butanol)
- 4 substituents (side chains) are numbered in the same way as for hydrocarbons.

### WORKED EXAMPLE 9.1

Name the following alcohol.



ANSWER	LOGIC
Propanol	<ul style="list-style-type: none"><li>▪ Determine the longest continuous chain to get base name – three carbons, so this is propane.</li><li>▪ Name as an alcohol – remove 'e' and add 'ol'.</li></ul>
2-propanol	<ul style="list-style-type: none"><li>▪ Determine placing of hydroxyl group and add to name.</li></ul>
Name includes: 2-methyl	<ul style="list-style-type: none"><li>▪ List substituents and numbers of each.</li></ul>
2-methyl-2-propanol	<ul style="list-style-type: none"><li>▪ Arrange substituents in alphabetical order ignoring any di-, tri- etc. prefixes and write final name.</li></ul>

### TRY THESE YOURSELF

Name the following alcohols.

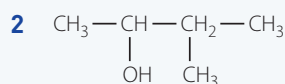
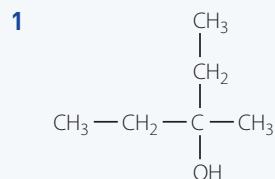
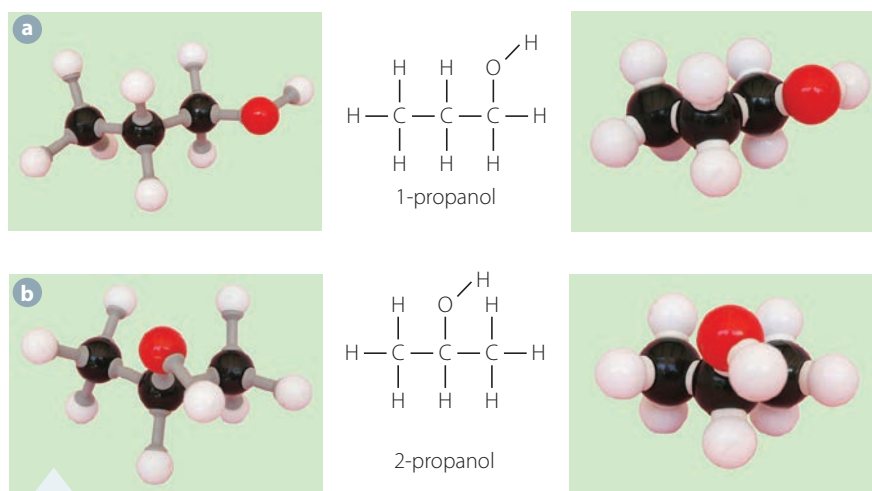


Figure 9.3 shows ball and stick, structural and space-filling models for 1-propanol and 2-propanol. These two molecules are isomers, having the same molecular formula but different structural formula, since they only vary in the position of the hydroxyl group. This is an example of a positional isomer.



**FIGURE 9.3** Ball and stick, structural and space-filling models for **a** 1-propanol and **b** 2-propanol

Alcohols show isomerism in exactly the same manner as the alkanes, alkenes and alkynes. The following worked example shows examples of position isomerism (position of the hydroxyl group) and chain isomerism (rearrangement of the carbon chain).

### WORKED EXAMPLE 9.2

Draw and name one chain isomer and one position isomer of 2-pentanol.

ANSWER	LOGIC
$  \begin{array}{c}  \text{OH} \\    \\  \text{CH}_3 - \text{C} - \text{CH}_2 - \text{CH}_3 \\    \\  \text{CH}_3  \end{array}  $ <p>2-methyl-2-butanol</p>	<ul style="list-style-type: none"> <li>▪ Chain isomer:           <ul style="list-style-type: none"> <li>- need to rearrange carbon chain</li> <li>- create a methyl group and shorten the main chain by one carbon.</li> </ul> </li> </ul>
$  \begin{array}{c}  \text{OH} \\    \\  \text{CH}_2 - \text{CH}_2 - \text{CH}_2 - \text{CH}_2 - \text{CH}_3  \end{array}  $ <p>1-pentanol</p>	<ul style="list-style-type: none"> <li>▪ Position isomer:           <ul style="list-style-type: none"> <li>- need to move the position of the hydroxyl group</li> <li>- move from second to the first carbon.</li> </ul> </li> </ul>

#### TRY THESE YOURSELF

- 1 Draw and name one chain isomer and one positional isomer of 2-methyl-2-propanol.
- 2 Draw and name two isomers of 1-hexanol where each is both a chain and positional isomer.

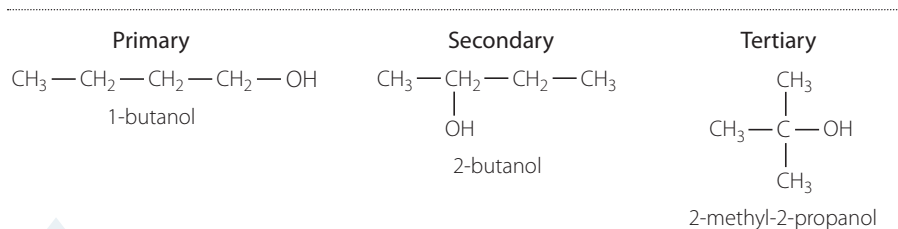
### Types of alcohols

Alcohols can be classified according to the number of carbon atoms attached to the carbon bearing the —OH group.

- A **primary alcohol** is one in which only one carbon atom is bonded to the carbon atom attached to the —OH group.

- ▶ A **secondary alcohol** is one in which two carbon atoms are bonded to the carbon attached to the —OH group.
- ▶ A **tertiary alcohol** is one in which three carbon atoms are bonded to the carbon attached to the —OH group.

Figure 9.4 shows primary, secondary and tertiary alcohols with the molecular formula  $C_4H_9OH$ .

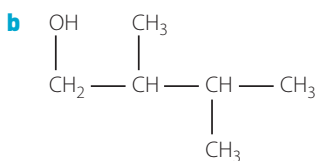
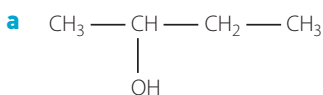


**FIGURE 9.4** Primary, secondary and tertiary alcohols

The three different groups of alcohols have different physical properties and chemical reactivity due to the different positions of the hydroxyl group in the molecule. Physical properties will be discussed in this chapter and chemical properties will be discussed in chapter 11.

- Organic compounds are grouped into families based on the presence of one or more particular group of atoms called 'functional groups'.
- Knowledge of the functional group allows you to predict physical and chemical properties of the entire group.
- Alcohols have a variety of uses including as fuels, alcoholic drinks, solvents, and the manufacture of a wide variety of synthetic products.
- Alcohols have a hydroxyl group (—OH), and general molecular formula  $C_nH_{2n+1}OH$ .
- Naming alcohols follows many conventions of naming other hydrocarbons, with the position of the —OH group indicated by a number within the name, and the name of the alcohol ending in 'ol'.
- Positional isomers occur when the carbon skeleton of a molecule is the same but the position of the functional group changes.
- Alcohols can be classed as primary, secondary or tertiary based on how many carbon atoms are bonded to the carbon attached to the —OH group.

- 1 Explain, using an example, what is meant by the term 'functional group'.
- 2 Identify three uses of alcohols.
- 3 Name and draw the functional group that is present in alcohol molecules.
- 4 Write the general formula for alcohols; hence, write the formula for alcohols with three, six and eight carbons.
- 5 Name the following alcohols.

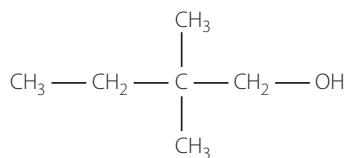
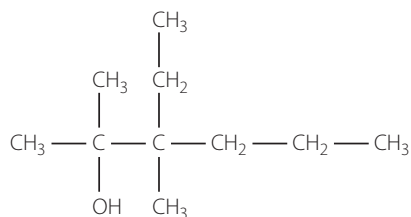


**CHECK YOUR  
UNDERSTANDING**

9.1

9.2a



**c****d**

- 6** Draw structural formulae for the following alcohols.
- 2-propanol
  - 3-methyl-1-butanol
  - 2,3-dimethyl-3-pentanol
  - 3-methyl-4-octanol
- 7** 2-hexanol and 3-hexanol are isomers.
- Identify and explain whether they are chain or positional isomers.
  - Draw and name a positional isomer of 2-hexanol that has not already been mentioned in this question.
  - Draw and name a chain isomer of 2-hexanol that has not already been mentioned in this question.
- 8** Explain, using examples, the difference between primary, secondary and tertiary alcohols.
- 9** For the alcohols in question **5** and **6**, identify each molecule as a primary, secondary or tertiary alcohol.

## Properties of alcohols

The hydroxyl group in alcohols contains a highly electronegative oxygen atom. Thus the C—O and O—H bonds are very polar. The rest of the alcohol molecule is a hydrocarbon molecule of varying size, depending upon the alcohol.

The properties of alcohols, including boiling points and solubility in water are dependent on two factors:

- the presence of the —OH group, which is capable of forming hydrogen bonds with other alcohol molecules and also with water
- the size of the hydrocarbon chain.

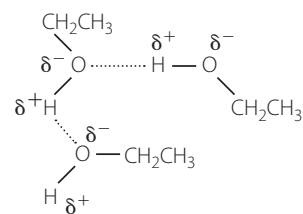
The hydroxyl group influences the boiling point of an alcohol compared to the alkanes, alkenes and alkynes, while the size of the hydrocarbon chain influences the properties within the alcohol homologous series.

### Boiling points

The boiling point of an organic compound relates to the energy required to overcome intermolecular forces between molecules. Recall that alkanes, alkenes and alkynes had relatively low melting and boiling points since they only formed dispersion forces between molecules.

Comparing butane to 1-butanol sees a molecule with similar length carbon chain, so the dispersion forces formed by each molecule will be approximately the same strength. However, 1-butanol also has the —OH group that can form hydrogen bonds with —OH groups on other 1-butanol molecules. Figure 9.5 shows the hydrogen bonding between ethanol molecules.

Hydrogen bonding is much stronger than dispersion forces, causing alcohols to have significantly higher boiling points than alkanes, alkenes and alkynes of similar molecular weight.



**FIGURE 9.5** Hydrogen bonding in liquid ethanol

## INVESTIGATION 9.1

### Data analysis – boiling point of alcohols

#### AIM

To investigate the boiling points of alcohols:

- within the alcohol homologous series
- compared to alkanes of similar molecular weight.

#### METHOD

- 1 Calculate the molecular weight of each of the alkanes and alcohols. Copy Table 9.2 to record your results.
- 2 Use a chemical data book or other reliable secondary sources to research the boiling points of the alkanes and the remaining alcohols. (Some data for alkanes is given in chapter 8.)
- 3 Construct a graph of molecular weight (horizontal axis) against boiling point (vertical axis).

**TABLE 9.2** Molecular weights and boiling points of the first eight alkanes and alcohols

ALKANE	MOLECULAR WEIGHT ( $\text{g mol}^{-1}$ )	BOILING POINT ( $^{\circ}\text{C}$ )	ALCOHOL	MOLECULAR WEIGHT ( $\text{g mol}^{-1}$ )	BOILING POINT ( $^{\circ}\text{C}$ )
Methane			Methanol		65
Ethane			Ethanol		78
Propane			1-propanol		97
Butane			1-butanol		118
Pentane			1-pentanol		138
Hexane			1-hexanol		
Heptane			1-heptanol		
Octane			1-octanol		

#### DISCUSSION

- 1 Butane and 1-butanol both have four carbons in their chain. Explain, using specific data from your table, why comparing their boiling points could be considered to be a non-valid comparison.





- » 2 Two isomers of 1-butanol are 2-butanol and 2-methyl-2-propanol. Their boiling points are 99.5°C and 83°C respectively.
- Explain the connection between these three molecules and why they can be compared more validly than the examples given in question 1.
  - Propose reasons why these molecules do not have the same boiling point.
- 3 Look at the trendline you have created for the alcohols.
- Describe the trend relating the molecular weight of the alcohol and its boiling point.
  - Explain the chemical reason for this trend.
- 4 Examine the two trendlines showing the boiling points of the alcohols and the alkanes.
- Explain, using correct chemical terminology, the trend seen on your graph.
  - Using data contained within this investigation, sketch a trendline to show the boiling points of 2-propanol, 2-butanol, 2-pentanol, 2-hexanol, etc. in comparison to the two plotted lines.

### CONCLUSION

With reference to the data obtained and its analysis, write a conclusion based on the aim of this investigation.

## Solubility

Solubility of alcohols relies on the balance between the polar functional group and the non-polar hydrocarbon chain of the molecule.

The polar —OH group forms hydrogen bonds with water, which makes short chain alcohols soluble in water. The non-polar hydrocarbon chain cannot form hydrogen bonds so is not soluble in water.

For the smaller alcohols, like methanol and ethanol, the effect of the polar hydroxyl group outweighs the effect of the non-polar hydrocarbon chain. Overall, these alcohols are very soluble in water. As the non-polar hydrocarbon chain increases in size, its effect begins to outweigh the effect of the polar hydroxyl group, making larger alcohols progressively less soluble in water. Larger alcohols become insoluble in water. Table 9.3 lists the solubility of some alcohols in water.

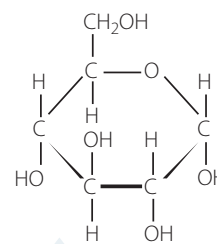
There are some larger alcohols that are soluble in water, despite the large size of their hydrocarbon chain. These molecules contain multiple hydroxyl groups instead of just one, multiplying the effect of the polar functional group.

**TABLE 9.3 Solubility of alcohols in water**

ALCOHOL	SOLUBILITY IN WATER (g/100 mL)
Methanol	Infinitely soluble
Ethanol	Infinitely soluble
Propanol	Infinitely soluble
1-butanol	7.7
1-pentanol	2.2
1-hexanol	0.59
1-heptanol	0.18
1-octanol	Insoluble in water
1-decanol	Insoluble in water

For these molecules, the overall effect of the multiple hydroxyl groups outweigh the large hydrocarbon chain and thus large molecules with hydroxyl groups can be water soluble.

An example of a large molecule that is very soluble in water is glucose,  $C_6H_{12}O_6$ . Glucose is a molecule with a high molecular mass ( $180.156\text{g mol}^{-1}$ ) but it is very soluble. Figure 9.6 shows a glucose molecule with five hydroxyl groups.



**FIGURE 9.6** Glucose molecule with multiple hydroxyl groups

## INVESTIGATION 9.2

### Solubility of alcohols

#### AIM

To investigate the solubility of alcohols with increasing length carbon chain.

#### HYPOTHESIS

Write a hypothesis for this investigation.

#### MATERIALS

- 4 mL of the alcohols methanol, ethanol, 1-propanol, 1-butanol, 1-pentanol and 1-hexanol
- Food colouring
- Deionised water
- 6 small test tubes
- Test-tube rack
- Pipette
- Digital camera
- Gloves
- Safety glasses

WHAT ARE THE RISKS IN DOING THIS INVESTIGATION?	HOW CAN YOU MANAGE THESE RISKS TO STAY SAFE?
Chemicals may splash and make skin contact.	Wear gloves, safety glasses and lab coat.
Fumes from organic compounds can be harmful.	Use small volumes of alcohols. Perform in a fume cupboard if available or a well-ventilated area. Keep chemicals containers closed unless being directly used.



What other risks are associated with your investigation? How can you manage these?

#### METHOD

- 1 Place six test tubes into the test-tube rack and label them 1–6 to represent the number of carbons in the six alcohols provided. If you have different alcohols, number the test tubes accordingly.
- 2 Place 3 mL deionised water in each test tube, along with two drops of food colouring. Food colouring is soluble in water, and not in non-polar substances.
- 3 Place 2 mL of each alcohol into the appropriate test tube, matching the carbon numbers to the numbers on the test tubes.



- » 4 Observe or take photos of each test tube, noting any layers that have formed, and which alcohols have fully mixed with the deionised water.
- 5 Add a further 2 mL of each alcohol to the appropriate test tube, noting any changes from the previous set of observations.

### RESULTS

Record your observations in an appropriate table pasting any images into the final column.

### DISCUSSION

- 1 Which of the alcohols were completely soluble? Were there any differences when extra alcohol was added in step 3? Propose a reason for any differences.
- 2 Did your results confirm your hypothesis? Explain, using specific examples from your results.
- 3 Describe the trend found in your experiment and explain the chemistry behind your observations.
- 4 Describe a way this investigation could be turned into a quantitative investigation. Outline changes or additions to the above method, including what you would be measuring.

### CONCLUSION

With reference to the observations made, write a conclusion based on the aim of this investigation.

- The hydroxyl functional group in alcohols is very polar and affects its physical properties.
- Physical properties of alcohols are affected by the polar functional group and the non-polar hydrocarbon chain.
- Alcohols have higher boiling points than alkanes, alkenes and alkynes of similar size due to the formation of hydrogen bonds between molecules.
- Alcohol boiling points increase as the molecule size increases due to more dispersion forces forming between the hydrocarbon chain.
- Smaller alcohols, or those with multiple hydroxyl groups, are water soluble since the functional group can form hydrogen bonds with water.
- As the length of the carbon chain increases, solubility decreases since the effect of the non-water soluble hydrocarbon chain outweighs the effect of the functional group.

### CHECK YOUR UNDERSTANDING

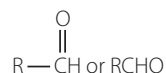
9.2b

- 1 Explain, using specific examples, whether it is more valid to compare molecules with the same number of carbon atoms or molecules of similar molecular weight.
- 2 By considering the bonding involved, explain why the —OH group has a large effect on the properties of alcohols.
- 3 Draw a diagram to show how hydrogen bonding occurs between 1-propanol molecules.
- 4 Explain why alcohols have significantly higher boiling points than alkanes, alkenes and alkynes of similar molecular weight.
- 5 Explain why:
  - a smaller alcohols are soluble in water
  - b solubility decreases as the hydrocarbon chain of the alcohol gets longer.
- 6 Explain, using an example, how a very large molecular weight alcohol can be soluble in water.
- 7 1-pentanol is a primary alcohol.
  - a Draw and name two isomers of 1-pentanol that are secondary and tertiary alcohols.
  - b Predict and explain whether these three molecules would have the same or different boiling points.

## 9.3 Aldehydes and ketones

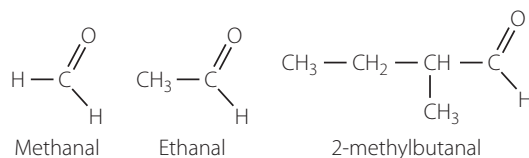
Compounds containing a carbon atom double bonded to an oxygen atom are called **carbonyl** compounds. Both aldehydes and ketones are carbonyl compounds.

Aldehydes are carbon compounds that contain a carbon–oxygen double bond at the end of the carbon chain. The compound is represented by the general molecular formula:



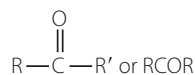
Note the condensed version of the formula includes  $-\text{CHO}$ , not to be confused with the condensed form of the alcohol group  $-\text{OH}$ . In the alcohol group, the carbon is attached to the oxygen that is attached to a hydrogen. There is no direct connection between the carbon and hydrogen of the functional group. In the aldehyde, both the oxygen and the hydrogen in the condensed formula are directly attached to the carbon.

Examples of aldehydes are:

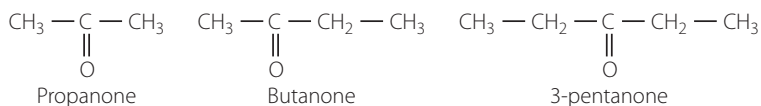


Methanal ( $\text{HCHO}$ ), commonly known as formaldehyde, is the simplest aldehyde. Methanal is used in vast quantities in the manufacture of plastics. The first plastic, known as bakelite, was made by using phenol (based on benzene) and formaldehyde.

Ketones differ from aldehydes in that the  $\text{C}=\text{O}$  can be located on any carbon except those at the ends of the hydrocarbon chain. The compounds have the general formula:



Examples of ketones are:



Propanone is widely used as a solvent, and is commonly known as acetone.

### Naming and drawing aldehydes and ketones and their isomers

Aldehydes are named by replacing the 'e' on the name of the hydrocarbon containing the  $\text{C}=\text{O}$  group with the suffix 'al'.

To name an aldehyde:

- 1 identify the longest carbon chain containing the  $-\text{CHO}$  group
- 2 delete the 'e' of the parent alkane and add 'al' (for example, ethane becomes ethanal)
- 3 number the carbon atoms of the main chain from the aldehyde. No number is needed for the aldehyde functional group since it is always at the end of the chain and so is always numbered as 1
- 4 name any alkyl groups as for branched alkanes.

To name a ketone:

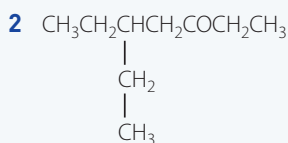
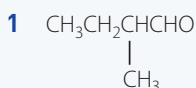
- 1 identify the longest carbon chain containing the C=O group
- 2 delete the 'e' of the parent alkane and add 'one' (for example, propane becomes propanone)
- 3 number the carbon atoms of the main chain from the end that results in the smallest number for the C=O group
- 4 add a number to the prefix to denote the position of the C=O group (for example, 2-pentanone)
- 5 name any alkyl groups as for branched alkanes.

Aldehydes and ketones are known as **functional group isomers**. These have the same molecular formula, but different functional groups, and hence, different structural formulae.

You can also draw aldehydes and ketones based on the rules above. Draw the parent chain, name the carbons, then place the carbonyl group as indicated by the name, and any alkyl chains.

### WORKED EXAMPLE 9.3

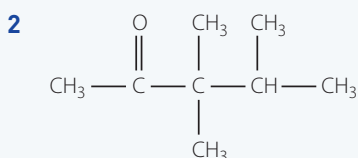
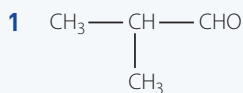
Identify each molecule as an aldehyde or a ketone and name them correctly.



ANSWER	LOGIC
1 Molecule 1 is an aldehyde.  2-methylbutanal	<ul style="list-style-type: none"><li>▪ First molecule has the carbonyl group at the end of the chain so is an aldehyde.</li><li>▪ Parent chain has four carbons; includes a methyl group on carbon 2.</li></ul>
2 Molecule 2 is a ketone.  5-ethyl-3-heptanone	<ul style="list-style-type: none"><li>▪ Second molecule has the carbonyl group in the middle so is a ketone.</li><li>▪ Parent chain has seven carbons; ketone group is on carbon 3 – ensure functional group has the smallest number; includes an ethyl group on carbon 5.</li></ul>

#### TRY THESE YOURSELF

Name the following aldehydes or ketones.



## Properties of aldehydes and ketones

Oxygen is more electronegative than carbon, so it has a strong tendency to attract electrons in the carbon–oxygen bond. This makes the carbon–oxygen bond highly polar. Because of this polarity, dipole–dipole forces form between molecules in aldehydes and ketones.

As a result, aldehydes and ketones have higher boiling points than hydrocarbons of similar molecular mass. Hydrocarbons have only weak dispersion forces so require less energy to break these intermolecular forces than the dipole–dipole forces formed between aldehyde and ketone molecules.

However, aldehydes and ketones have lower boiling points than alcohols of similar size. Alcohols form hydrogen bonds between molecules due to the presence of the hydroxyl group. Hydrogen bonds are stronger than dipole–dipole forces so require more energy to break.

The carbonyl group, being highly polar, does form an attraction to highly polar water molecules. This makes aldehydes and ketones more soluble than hydrocarbons, but less soluble than alcohols.

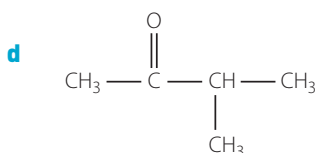
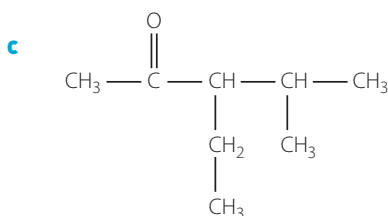
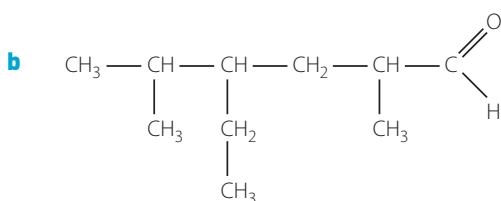
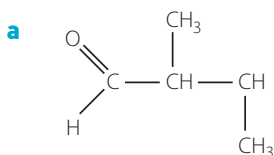
Small aldehydes and ketones are soluble in water, but as chain length increases, solubility in water decreases. This is because the longer hydrocarbon component of the molecule begins to outweigh the effect of the polar carbonyl group.

- Aldehydes and ketones contain a carbonyl group, which has a carbon–oxygen double bond (C=O).
- Aldehydes have the carbonyl group at the end of a carbon chain; ketones have the group on any carbon other than the end carbons.
- Aldehydes have general molecular formula RCHO; ketones have general molecular formula RCOR'.
- Aldehydes and ketones are named in a similar manner to alcohols, with names ending in 'al' for aldehydes and 'one' for ketones. The position of the carbonyl group in ketones is indicated by a number.
- The carbonyl group is highly polar, allowing for formation of dipole–dipole bonds between molecules.
- Aldehydes and ketones have higher boiling points than alkanes, alkenes and alkynes, but lower than alcohols of similar size.
- Aldehydes and ketones are more soluble in water than alkanes, alkenes and alkynes, but lower than alcohols of similar size.

- 1 Describe the structure of a carbonyl functional group. Use a diagram in your answer.
- 2 Explain the structural difference between an aldehyde and a ketone.
- 3 Name the following compounds.

CHECK YOUR  
UNDERSTANDING

9.3



- 4 Draw the structural formula of the following.
- Butanal
  - 4-methylpentanal
  - 3-hexanone
  - 3-methyl-2-pentanone
- 5 Describe the type of bonding that forms between aldehyde and ketone molecules and explain why these bonds form.
- 6 Consider the following compounds: 1-propanol, butane and propanal.
- Calculate the molecular weight of each compound and explain why their physical properties can be validly compared.
  - Rank the three compounds in order of increasing boiling point. Explain your answer.
- 7 Explain why smaller aldehydes like ethanal are water soluble but larger aldehydes like hexanal are not.
- 8 The alcohol 1-pentanol is slightly soluble in water, while pentanal is not. Explain this observation.

## 9.4 Carboxylic acids



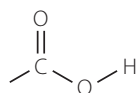
**FIGURE 9.7** Ants inject formic acid when they bite, causing a 'sting'.

Carboxylic acids can be found throughout nature. A few of the more common acids are methanoic acid (also known as formic acid) a chemical defence for some ants, injected when they bite (Figure 9.7). Acetic acid is found in vinegar, propanoic acid in cheese, butanoic acid in spoiled butter, citric acid in citrus fruits and lactic acid in milk and other dairy products. Many of these carboxylic acids have strong and unpleasant odours.

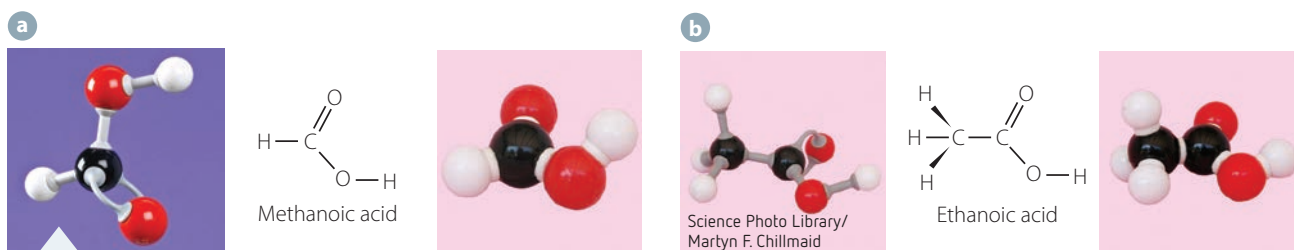
Synthetic compounds manufactured from carboxylic acids include soap, some plastics, pharmaceuticals and herbicides.

Carboxylic acids contain the carboxyl functional group, which is always found at the end of the parent chain of the molecule. While it looks like carboxylic acids contain a carbonyl (C=O) and a hydroxyl (—OH) group, when they are arranged together like this, it is called a **carboxyl** group and is considered to be one single functional group.

The configuration of the carboxyl group is:



This group has the general molecular formula  $\text{C}_n\text{H}_{2n+1}\text{COOH}$ . Figure 9.8 shows methanoic and ethanoic acid, the two simplest carboxylic acids.



**FIGURE 9.8** Ball and stick, structural and space-filling models for **a** methanoic acid and **b** ethanoic acid



As described above, many carboxylic acids have common names. Methanoic acid is formic acid, while ethanoic acid is more commonly known as acetic acid. Propanoic acid is also propionic acid and butanoic acid is also butyric acid. Citric acid and lactic acid are also commonly used names, but not their IUPAC systematic name. It is important to know how to name this group according to IUPAC rules, while also being familiar with common names.

## Naming and drawing carboxylic acids and their isomers

To name a carboxylic acid:

- 1 identify the longest carbon chain containing the  $\text{—COOH}$  group
- 2 delete the 'e' of the parent alkane and add 'oic acid' (for example, ethane becomes ethanoic acid)
- 3 number the carbon atoms of the main chain from the acid group; no number is needed for the acid functional group, which is always at the end of the carbon chain so will always be numbered as 1
- 4 name any alkyl groups as for branched alkanes.

Drawing carboxylic acids is done by using the above rules, placing the carboxyl functional group on the first carbon, and placing alkyl chains as indicated by the name.

## Properties of carboxylic acids

The presence of the  $\text{—OH}$  and  $\text{C=O}$  groups makes the entire carboxyl group polar. Carboxylic acids are capable of forming a range of intermolecular forces between molecules. The hydrocarbon chain will form dispersion forces, while the  $\text{C=O}$  carbonyl part of the functional group will form dipole–dipole forces due to its high polarity. The  $\text{—OH}$  part of the functional group will form hydrogen bonds in the same way alcohols do.

### Boiling point

Overall, carboxylic acids have much stronger intermolecular forces than any of the molecules discussed so far. Alcohols have primarily hydrogen bonding, aldehydes and ketones have primarily dipole–dipole forces, and alkanes, alkenes and alkynes have only dispersion forces.

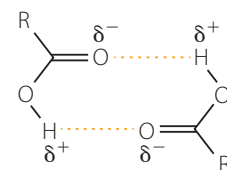
Since it requires more energy to overcome the intermolecular forces between carboxylic acid molecules, this group will have higher boiling points than other molecules of similar size. For example, 1-propanol has a boiling point of  $97.2^\circ\text{C}$ , while ethanoic acid, with a similar molecular mass, has a boiling point of  $118^\circ\text{C}$ .

Within the carboxylic acid homologous series, the boiling points increase as the length of the carbon chain increases. This is due to the increasing number of the dispersion forces that form between the longer chain molecules. This is the same effect seen in alkanes, alkenes, alkynes, aldehydes, ketones and alcohols.

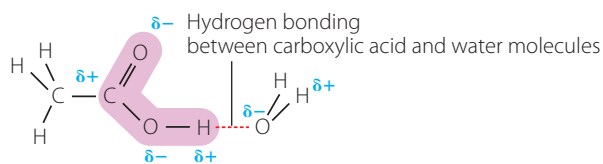
Under certain circumstances a pure carboxylic acid will form a structure called a **dimer**, as seen in Figure 9.9.

In a dimer, two carboxylic acid molecules form intermolecular bonds between the  $\text{C=O}$  part of the carboxyl group on one molecule and the  $\text{—OH}$  part on a different molecule. As you can see in Figure 9.9, this arrangement forms two hydrogen bonds between each pair of molecules, increasing the boiling point of carboxylic acids.

It may be unexpected that the carbonyl component of the functional group can form hydrogen bonds, as it would normally be expected to form dipole–dipole intermolecular forces. In a carboxyl functional group, the carbonyl group and the hydroxyl group interact with each other, so neither the carbonyl or hydroxyl function in the same way as if they were an isolated functional group. The chemistry of their interaction is beyond the scope of this course, but be aware it does lead to some bonds forming you might not normally predict. A dimer is one example of this interaction.



**FIGURE 9.9** A dimer forms between two carboxylic acid molecules under certain circumstances.



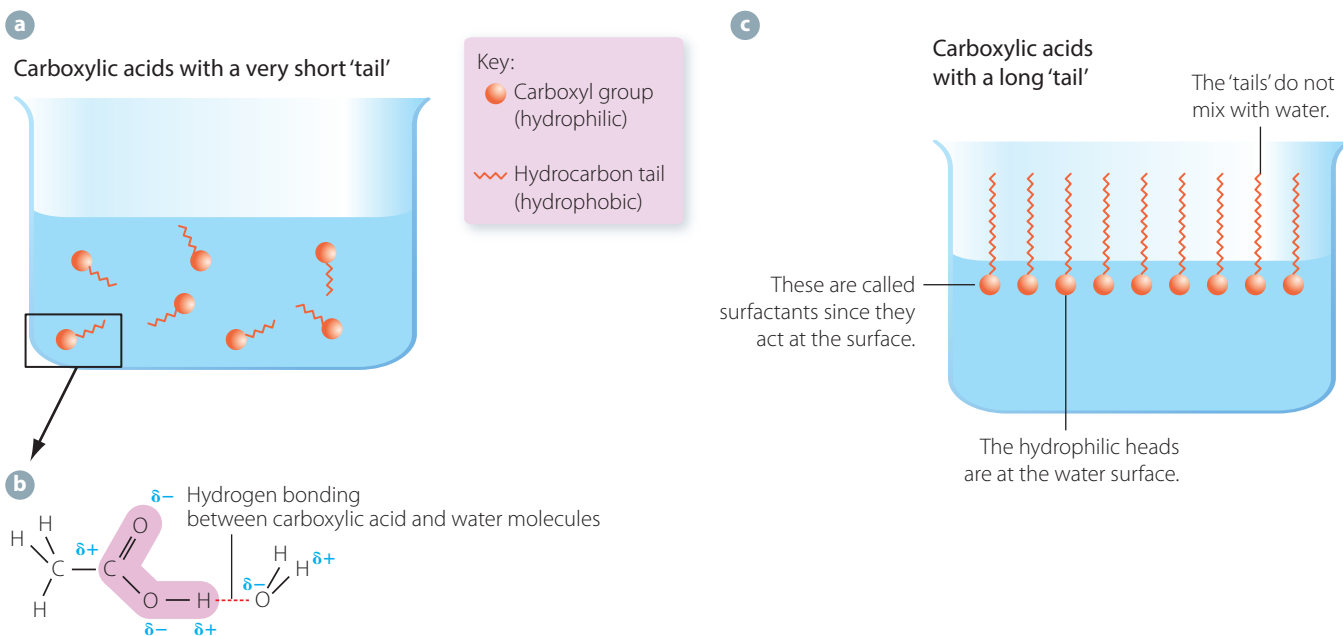
**FIGURE 9.10** Carboxylic acids form hydrogen bonds with water.

the non-polar tail prevents the acids being soluble in water. These molecules line up at the surface of the water (as shown in Figure 9.11) and are known as surfactants. You will investigate the action and use of surfactants in later chapters.

## Solubility

Small carboxylic acids like methanoic acid and ethanoic acid are very soluble in water. The carboxyl functional group forms hydrogen bonds with water, as seen in Figure 9.10.

In smaller acids, the effect of the non-polar hydrocarbon chain is small so is outweighed by the effect of the very polar carboxyl groups ability to form hydrogen bonds. In larger acids,



**FIGURE 9.11** The interaction between different length carboxylic acids and water

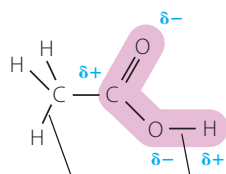
Since the carboxyl group is more polar than other functional groups seen so far, their ability to form hydrogen bonds with water, and hence their solubility, is far greater. Pentanal (an aldehyde), 1-pentanol (an alcohol), and butanoic acid have very similar molecular weights, but large differences in solubility and boiling point due to the differences in intermolecular forces. The values for solubility and boiling point can be seen in Table 9.4.

**TABLE 9.4** Solubility and boiling point of comparable alcohol, aldehyde and carboxylic acid molecules

NAME	MOLECULAR WEIGHT	BOILING POINT (°C)	SOLUBILITY (g/100 mL)
Butanoic acid	88.1	163	Infinite
1-pentanol	88.1	137	2.3
Pentanal	86.1	103	Slight

## Monoprotic nature

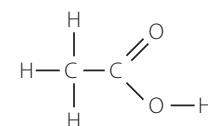
The carboxylic acid group is monoprotic. This is because the only H atom that can react with a base is the one in the —COOH group. This is shown in Figure 9.12. As a monoprotic acid, they have the same properties of acids as discussed in previous modules.



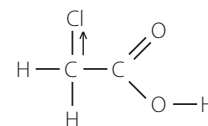
This bond is virtually non-polar and so this H cannot be drawn away and leave its electron behind.

This bond is highly polar. Since the electrons spend more time near the O atom, H can be drawn away by a base and leave its electron behind.

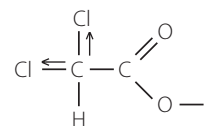
**FIGURE 9.12** Ethanoic acid is a monoprotic acid.



Ethanoic acid



Chloroethanoic acid



Dichloroethanoic acid

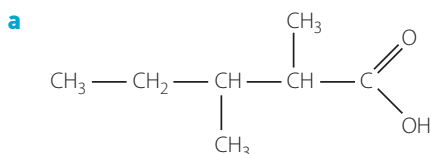
**FIGURE 9.13**  
Substituted  
carboxylic acids

Carboxylic acids are weak acids, so they will partially ionise when in solution, producing hydrogen ions. Different acids ionise to different extents. Citric acid ionises to 8.6%, while acetic acid only ionises to 1.3%.

The strength of a carboxylic acid can be increased by substituting a highly electronegative atom such as a halogen onto the hydrocarbon chain. As the number of substituted atoms increases, so does the strength of the acid. This is because the strong electron-attracting power of the substituent weakens the oxygen–hydrogen bond in the —OH group and makes it easier to form  $H^+$  ions. This is shown in Figure 9.13; dichloroethanoic acid is almost 3000 times stronger than ethanoic acid. As the number of electronegative atoms increases, so does the strength of the acid.

- Carboxylic acids have a carboxyl functional group that contains carbonyl (C=O) and hydroxyl (—OH) components, with general molecular formula  $C_nH_{2n+1}COOH$ .
- Many carboxylic acids have common names as well as their IUPAC systematic names.
- Carboxylic acids are named in a similar manner to aldehydes since the functional group is always on the end carbon. Names end in 'oic acid'.
- The carboxyl group is highly polar, which affects boiling points and solubility of the carboxylic acids.
- Carboxylic acids have higher boiling points and increased solubility when compared to alcohols, aldehydes, ketones, alkanes, alkenes and alkynes of similar molecular weight.
- Carboxylic acids can form dimers under certain circumstances.
- Carboxylic acids have higher boiling points but decreasing solubility as their carbon chain length increases.
- Carboxylic acids are weak, monoprotic acids.

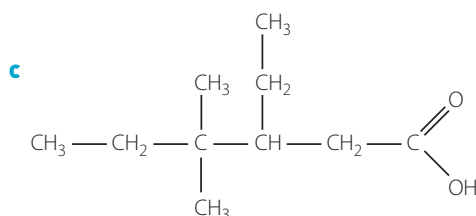
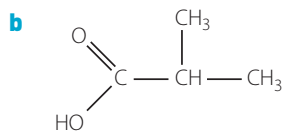
- 1 Draw the carboxyl functional group, labelling the polarity of the atoms involved.
- 2 Many carboxylic acids have common names as well as IUPAC names.
  - a Explain what is meant by an IUPAC name.
  - b Identify three carboxylic acids with their common and IUPAC names.
- 3 Name the following compounds.



**CHECK YOUR  
UNDERSTANDING**

9.4





- 4 Draw the structural formula of the following.
- Heptanoic acid
  - 3-methylbutanoic acid
  - 2,3-dimethylbutanoic acid
- 5 Explain why the boiling points of the carboxylic acids increases as their chain length increases.
- 6 The following molecules represent different groups of organic compounds: 1-pentanol, pentanal, hexane, pentanoic acid, 2-pentanone.
- For each molecule, identify the homologous series it belongs to, and name the functional group.
  - For each molecule, identify the types of intermolecular bonding that forms between those molecules.
  - Arrange the molecules in order of increasing boiling points. Justify your answer.
- 7 Draw the dimer that forms between two ethanoic acid molecules, labelling the resulting intermolecular bonds.
- 8 Explain why the presence of the carboxyl group can result in water solubility for some carboxylic acids.
- 9 Explain why octanoic acid will be much less soluble than propanoic acid.
- 10 Explain, using structural diagrams of each molecule, why chloroethanoic acid is a much stronger acid than ethanoic acid.

## 9.5 Amines and amides

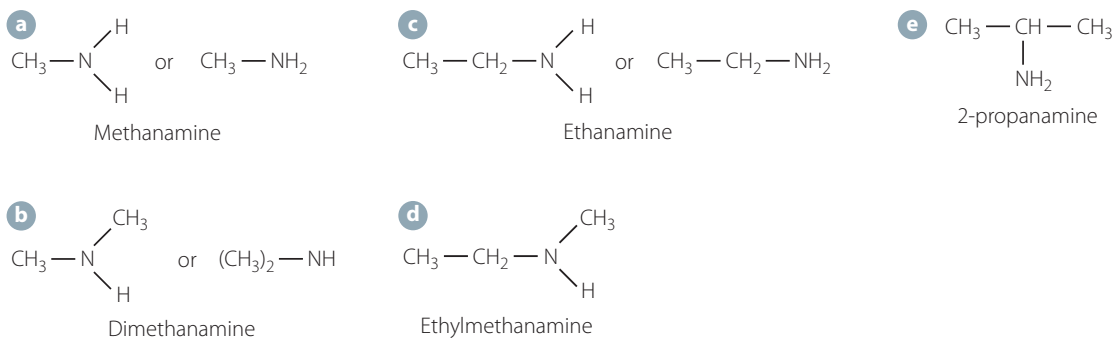
Amines have a wide range of uses as catalysts and solvents and in the manufacture of dyes, medicines and polymers, so they are an extremely important family of organic compounds. Amines are also widely found in nature as **amino acids**, which are the building blocks of **proteins**.

An amide is formed when an amine reacts with a carboxylic acid. Polyamides are an important group of synthetic plastics.

Urea, an important compound in industry and living systems, is also known as carbamide with the formula  $\text{H}_2\text{N}-\text{CO}-\text{NH}_2$ . It has two  $\text{NH}_2$  groups attached to a carbonyl ( $\text{C}=\text{O}$ ) group. Urea was the first organic compound to be synthesised from inorganic starting materials, thus showing organic compounds were part of a chemical system and could be produced outside living things.

### Amines

The amine or **amino** functional group is  $-\text{NH}_2$ . Amines are compounds in which one or more atoms of hydrogen in ammonia ( $\text{NH}_3$ ) are replaced by a carbon-containing group, such as an alkyl group. Alkyl amines are represented by the general formula  $\text{RNH}_2$ . Some simple amines are shown in Figure 9.14.



**FIGURE 9.14** Some simple amines

Amines may be classified as primary, secondary or tertiary depending on the number of alkyl groups attached to the nitrogen. A **primary amine** has one alkyl group (Figure 9.14a and Figure 9.14c), a **secondary amine** has two alkyl groups attached to the nitrogen (Figure 9.14b) and a **tertiary amine** has three alkyl groups attached to the nitrogen (for example,  $(\text{CH}_3)_3\text{N}$ ).

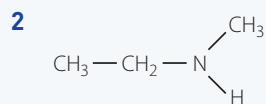
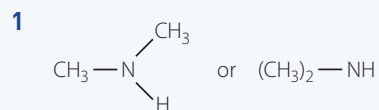
## Naming amines

To name a simple amine:

- 1 identify the carbon chains attached to the N and put them in alphabetical order (using the alkyl name except for the final group) with no spaces
- 2 delete the 'e' from the last alkane name and add 'amine' (for example, ethane becomes ethanamine (Figure 9.14c)); if there is an ethyl and a methyl chain, then the name would be ethylmethanamine.
- 3 add the prefixes di- and tri- if two or three of the alkyl groups are the same (Figure 9.14b)
- 4 number the carbons on the main chain from the end nearest the amine group; if the amine group is not on the end, its location is shown by stating the number of the carbon to which it is attached at the front of the name (for example, 2-propanamine (Figure 9.14e))
- 5 name any alkyl group attached to the main carbon chain according to the conventions for naming alkanes.

### WORKED EXAMPLE 9.4

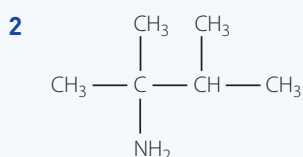
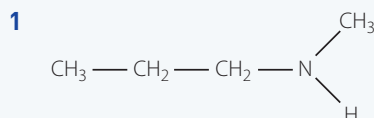
Name the following amines.



ANSWER	LOGIC
1 Dimethanamine	<ul style="list-style-type: none"> <li>Attached to the nitrogen are two (di-) methyl groups – so name will contain methanamine: (methan - 'e') + amine.</li> </ul>
2 Ethylmethanamine	<ul style="list-style-type: none"> <li>Attached to the nitrogen is an ethyl and a methyl group (placed in alphabetical order).</li> <li>Methyl group becomes methanamine since it is last alphabetically.</li> <li>Ethyl group placed before and named as an alkyl group.</li> </ul>

### TRY THESE YOURSELF

Name the following amines.



## Drawing amines

To draw an amine:

- if the amine group is not at the end of the chain:
  - draw the main carbon chain
  - number the carbons
  - position the amine and any other alkyl groups as substituents on the appropriate carbon.
- if the amine group is at the end of the chain:
  - draw with the nitrogen atom
  - identify the alkyl groups from the molecule name (for example, ethylmethanamine has an ethyl and a methyl group)
  - add the alkyl groups to the nitrogen atom
  - the nitrogen atom should have three bonds (fill any spare bonds with hydrogen).

### WORKED EXAMPLE 9.5

Draw the amine methylpropanamine.

ANSWERS	LOGIC
$\text{CH}_3 - \text{N} \begin{array}{l} \diagup \text{CH}_2 - \text{CH}_2 - \text{CH}_3 \\ \diagdown \end{array}$	<ul style="list-style-type: none"> <li>Draw the central nitrogen atom.</li> <li>Identify the alkyl groups from the name: methyl and propyl groups.</li> <li>Add the alkyl groups to the nitrogen atom.</li> </ul>
$\text{CH}_3 - \text{N} \begin{array}{l} \diagup \text{CH}_2 - \text{CH}_2 - \text{CH}_3 \\   \\ \text{H} \end{array}$	<ul style="list-style-type: none"> <li>Add hydrogens to the nitrogen atom until it has three bonds.</li> </ul>

### TRY THESE YOURSELF

Draw the following amines.

- 1 3-methyl-2-butanamine
- 2 Ethylpropanamine

## Properties of amines

Nitrogen is the third most electronegative element after fluorine and oxygen, so the  $\text{—NH}_2$  functional group is very polar. Primary and secondary amines can form hydrogen bonds due to the presence of  $\text{N—H}$  bonds within the molecule. Because nitrogen is less electronegative than oxygen, the hydrogen bonds formed by amines are weaker than those formed by alcohols. This results in the boiling points of amines being lower than those of similar sized alcohols. The hydrogen bonding also means the smaller amines are soluble in water. Tertiary amines cannot form hydrogen bonds because there is no  $\text{N—H}$  bond in the molecule. Consequently, their boiling points are lower than those of primary and secondary amines and they are generally insoluble in water.

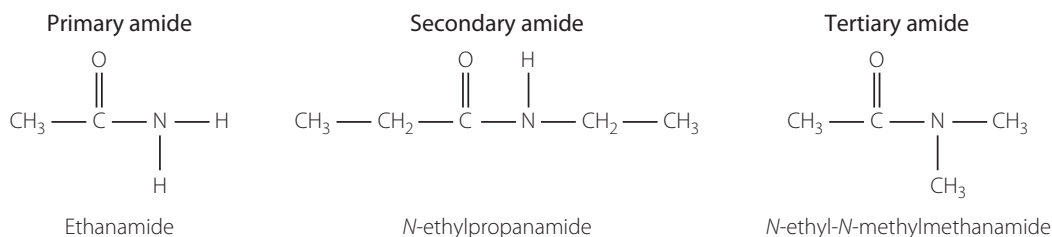


Trends in alkanes,  
amines and carboxylic  
acids

- Amines contain the functional group  $\text{—NH}_2$  and have the general molecular formula  $\text{RNH}_2$ .
- Amines are compounds in which one or more atoms of hydrogen in ammonia ( $\text{NH}_3$ ) are replaced by an alkyl group.
- Amines are classed as primary, secondary or tertiary depending on the number of alkyl groups attached to the nitrogen.
- Amines are named by identifying the alkyl groups attached to the nitrogen and ordering alphabetically, giving the last one an 'amine' ending.
- Drawing amines is done by adding the alkyl groups in the name to a nitrogen atom and filling the nitrogen bonds by adding hydrogen.
- The amine functional group is very polar, which gives amines high melting and boiling points, and good solubility in water.
- As amines become larger, their melting and boiling points increase and their solubility decreases.

## Amides

Amides are derivatives of carboxylic acids and are formed when the  $\text{—OH}$  group of the acid is replaced by an amine ( $\text{—NH}_2$ ,  $\text{—NHR}$ ) group. The amide formed is a stable covalent molecule with no acidic or basic properties. Amides all contain the structural unit  $\text{—CO—NH—}$ , which is shown in Figure 9.15. This amide link occurs in proteins and **polyamides**. As with amines, amides are classified as **primary**, **secondary** or **tertiary amides** depending on the number of alkyl chains attached to the nitrogen.



**FIGURE 9.15** Primary, secondary and tertiary amides. Note the common structure of the amide group in the main chain.



## Naming amides

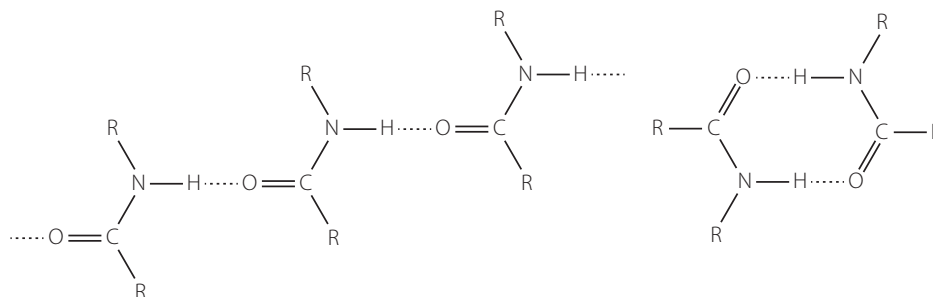
To name an amide:

- 1 change the ending of the acid name (the alkyl group including the C=O bond) by replacing '–oic acid' with 'amide' (for example, ethanoic acid becomes ethanamide)
- 2 name any alkyl groups bonded to the nitrogen atom as *N*-alkyl in front of the amide name (for example, in Figure 9.15 the second molecule has an ethyl group attached to the nitrogen so is *N*-ethyl); the *N*- designation on the alkyl groups shows that the alkyl group is directly attached to the nitrogen atom
- 3 a tertiary amide with three alkyl groups in the name is named according to the following examples:
  - ▶ an amide with two methyl groups and an ethyl group would be *N*-ethyl-*N*-methylmethanamide
  - ▶ an amide with three methyl groups would be *NN*-dimethylmethanamide.

## Properties of amides

Primary and secondary amides have two very polar bonds, the N–H and the C=O. Tertiary amides only have the C=O since the nitrogen is attached to three alkyl groups, so no N–H bond exists.

This means primary and secondary amides can form hydrogen bonds between molecules. They can also form dimers with hydrogen bonds forming between the N–H on one molecule and the C=O of a different molecule. Bonding between amide molecules is seen in Figure 9.16.



**FIGURE 9.16** Bonding between multiple amide molecules (left) and dimer formation (right)

The hydrogen bonds between molecules give amides higher melting and boiling points that might be expected for the size of the molecule. Many amides are solid at room temperature.

Small amides are soluble in water since the amide group can form hydrogen bonds with water molecules. As the molecule becomes larger, solubility decreases since the non-polar hydrocarbon chain begins to outweigh the effect of the polar amide group.



Check your understanding

- Amides contain the functional group  $\text{—CO—NH}_2$  and have the general molecular formula  $\text{RCONHR}'$ .
- Amides are classified as primary, secondary or tertiary based on the number of alkyl chains on the nitrogen.
- Amides are named by changing the name of the carboxylic acid it is based on, ending the name with 'amide'. Alkyl groups are named with *N*-alkyl.
- Amides have two polar bonds in the functional group, which allows them to form strong intermolecular forces, resulting in high melting and boiling points and high solubility in water.
- Boiling points of amides increases, but solubility decreases as the carbon chain increases in length.

- 1 Draw and label the structural units that identify a substance as an amine or amide.
- 2 Describe the relationship between an amine and an amide.
- 3 Name the following compounds and identify them as primary, secondary or tertiary.
  - a  $\text{CH}_3\text{—CH}_2\text{—CH}_2\text{—NH}_2$
  - b  $(\text{CH}_3\text{—CH}_2)_3\text{N}$
  - c 
$$\begin{array}{c} \text{CH}_3\text{—CH—CH—CH}_3 \\ | \quad | \\ \text{NH}_2 \quad \text{CH}_3 \end{array}$$
  - d 
$$\begin{array}{c} \text{CH}_3\text{—C—N—H} \\ || \quad | \\ \text{O} \quad \text{H} \end{array}$$
  - e 
$$\begin{array}{c} \text{CH}_3\text{—N—C—CH}_3 \\ | \quad || \\ \text{H} \quad \text{O} \end{array}$$
  - f 
$$\begin{array}{c} \text{CH}_3\text{—CH}_2\text{—CH}_2\text{—N—C—CH}_3\text{—CH}_3 \\ | \quad || \\ \text{H} \quad \text{O} \end{array}$$
- 4 Draw the structure of each of the following.
  - a Hexanamine
  - b Dipropanamine
  - c 2-methyl-3-octanamine
  - d Propanamide
  - e *N*-methylmethanamide
- 5 Explain the type of bonding that amines and amides form between molecules and explain how this impacts upon their melting and boiling points.
- 6 Explain why tertiary amines:
  - a are insoluble in water
  - b do not form amides
  - c have lower boiling points than primary or secondary amines.
- 7 Why does the solubility of amines and amides decrease as the molecule becomes larger?
- 8 Explain, with reference to the functional group, why the properties of tertiary amides are different to the properties of primary and secondary amides.

# 9 CHAPTER SUMMARY

## IMPORTANT NEW TERMS

After studying this chapter you should know the meaning of the following terms:

alcohol (p. 263)

aldehyde (p. 263)

amide (p. 263)

amine (p. 263)

amino (p. 280)

amino acid (p. 280)

carbonyl (p. 273)

carboxyl (p. 276)

carboxylic acid (p. 263)

dimer (p. 277)

ester (p. 263)

functional group isomer (p. 274)

functional group (p. 263)

homologous series (p. 263)

hydroxyl (p. 263)

ketone (p. 263)

polyamide (p. 283)

primary/secondary/tertiary alcohol (p. 266, 267)

primary/secondary/tertiary amide (p. 283)

primary/secondary/tertiary amine (p. 281)

protein (p. 280)

R group (p. 263)

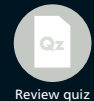
## AFTER STUDYING THIS CHAPTER YOU SHOULD KNOW:

- the definitions for all terms in the important new terms list
- the IUPAC conventions for naming organic chemicals (up to C8, for primary, secondary and tertiary alcohols, aldehydes, ketones, carboxylic acids, amines and amides)
- the functional groups for alcohols, aldehydes, ketones, carboxylic acids, amines and amides
- the intermolecular forces that form between pure samples of each type of organic compound: alcohols, aldehydes, ketones, carboxylic acids, amines and amides
- the trends in boiling points, melting points and solubility within each of alcohols, aldehydes, ketones, carboxylic acids, amines and amides.

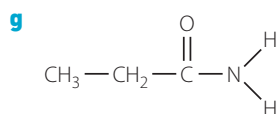
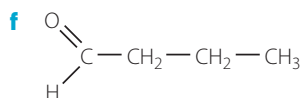
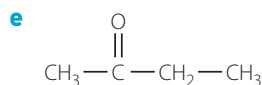
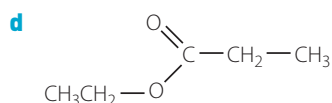
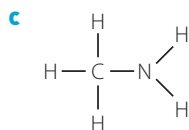
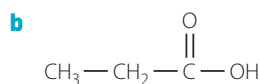
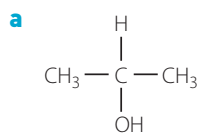
## YOU SHOULD BE ABLE TO:

- name alcohols, aldehydes, ketones, carboxylic acids, amines and amides (up to C8, including simple methyl and ethyl branched chains)
- identify alcohols, amines and amides as primary, secondary or tertiary
- draw structural and molecular formula for alcohols, aldehydes, ketones, carboxylic acids, amines and amides, up to C8, including simple methyl and ethyl branched chains
- compare the melting/boiling points and solubility of similar molecular weight molecules from organic groups
- explain the differences in melting/boiling points and solubility of different group molecules using intermolecular bonding
- explain the trends in boiling points, melting points and solubility within each of alcohols, aldehydes, ketones, carboxylic acids, amines and amides.

# 9 CHAPTER REVIEW QUESTIONS



1 Identify the functional group in each of the following compounds.

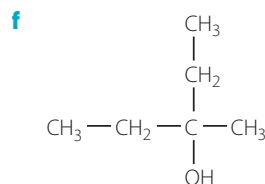
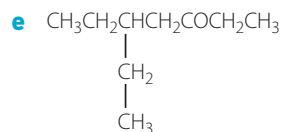
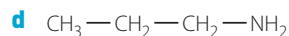
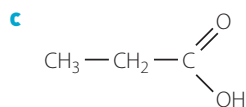
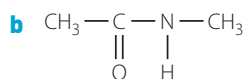
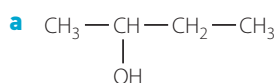


2 In general, in organic formulae an R group is often used. Explain what the R group represents.

3 Identify the functional group, draw its structure and give the general formula for alcohols, aldehydes, ketones and carboxylic acids.

4 Distinguish between an amine and amide in terms of structure and physical properties.

5 For each of the following molecules, identify the homologous series it belongs to and write its correct IUPAC name.



6 Draw structural formulae for the following.

**a** 2-heptanol

**b** 4,5-dimethyl-2-hexanone

**c** 2-ethylbutanoic acid

**d** 3-ethyl-1-hexanol

**e** Pentanamide

**f** 3-heptanamine

**g** *N*-methylpropanamide

**h** 2-fluorobutanal

**i** 3-methyl-2-butanone

7 Identify one alcohol, one aldehyde and one carboxylic acid that have common names. Draw each molecule and give its correct IUPAC name.

8 Draw structural formulae for the following and give the systematic names for:

**a** all isomers with molecular formula  $\text{C}_3\text{H}_8\text{O}$

**b** carboxylic acids with molecular formula  $\text{C}_4\text{H}_8\text{O}_2$ .

9 Compare the intermolecular forces and relative boiling points of the following classes of organic compounds.

**a** Alkanes and alcohols

**b** Carboxylic acids and aldehydes

**c** Alcohols and aldehydes

**d** Amines and amides

10 Using examples from the alcohol, aldehyde, ketone, carboxylic acid, amine or amide groups:

**a** explain the difference between chain and positional isomers

**b** explain the term 'functional group isomer'

11 Using the molecules 1-pentanol, 2-pentanol and 2-methyl-2-propanol, explain the difference between primary, secondary and tertiary alcohols.

- 12** Draw structures to describe the difference between primary, secondary and tertiary:
- amines
  - amides.
- 13** Explain why molecules like glucose are soluble in water despite their high molecular weight.
- 14** Explain why the solubility of carboxylic acids and alcohols decreases as the length of their carbon chains increase.
- 15** Explain why the boiling points of organic groups increase as the length of their carbon chains increase.
- 16** Explain, using a specific example, how a dimer forms between two molecules. Use a diagram in your answer.
- 17** Carboxylic acids are weak acids. Describe one way their structure can be modified so their strength is increased.
- 18** Explain why citric acid is considered to be 'more acidic' than ethanoic acid.
- 19** Explain why tertiary amines have lower boiling points and decreased solubility than similar molecular mass primary and secondary amines.
- 20** Ethanol and water readily dissolve in each other, as do ethanol and hexane. However, water and hexane do not dissolve in each other.
- Draw structures of each molecule and explain whether it is polar or non-polar.
  - Explain why water and hexane do not dissolve in each other.
  - Explain, using diagrams showing intermolecular bonds, why ethanol can dissolve in both water and hexane.
  - Considering your answer to part **c**, explain why ethanol is a widely used solvent in industry.
- 21** Three compounds are known to be 1-propanol, ethanoic acid and propanone. Their boiling points (not in order) are 56°C, 118°C and 97°C. Match the correct boiling point to the compound, giving reasons for your answer.
- 22** Consider the table below showing the boiling points of various organic substances.
- Plot a graph of 'number of carbons' against boiling point for each of the three organic groups.
  - Identify and explain two trends seen on the graph.
  - Sketch trendlines to predict the approximate boiling points of the ketone and amine groups and explain the lines you have drawn.
  - Suggest a more valid way to compare these molecules than by 'number of carbons'.

PRIMARY ALCOHOL	BOILING POINT (°C)	ALDEHYDE	BOILING POINT (°C)	CARBOXYLIC ACID	BOILING POINT (°C)
Ethanol	78.3	Ethanal	47.9	Ethanoic acid	140.8
1-propanol	97.2	Propanal	74.8	Propanoic acid	163.3
1-butanol	117.7	Butanal	102.5	Butanoic acid	185.5
1-pentanol	138.0	Pentanal	128.7	Pentanoic acid	205.7

# 10 Hydrocarbon reactions

## INQUIRY QUESTION

What are the products of reactions of hydrocarbons and how do they react?

### Students:

investigate, write equations and construct models to represent the reactions of unsaturated hydrocarbons when added to a range of chemical, including but not limited to:

- hydrogen ( $H_2$ )
- halogens  $X_2$
- hydrogen halides (HX)
- water ( $H_2O$  ACSCH13) ICT

investigate, write equations and construct models to represent the reactions of saturated hydrocarbons when substituted with halogens

describe the procedures required to safely handle and dispose of organic substances ACSCH07) ICT

examine the environmental, economic and sociocultural implications of obtaining and using hydrocarbons from the Earth.

Chemistry Stage 6 Syllabus © NSW Educational Standards Authority for and on behalf of the Crown in right of the State of New South Wales, 2017







The presence of the double and triple bonds in alkenes and alkynes make them very reactive, and they can undergo a range of reactions with substances like halogens, water and hydrogen. They also take part in **polymerisation** reactions, which will be discussed in a later chapter. Alkanes are far less reactive; however, they undergo combustion and substitution reactions.

The use of organic chemicals in these types of reactions presents some hazards, so it is important to be able to identify possible risks and take suitable precautions for the use and disposal of these chemicals.

Many alkanes are used for fuels, undergoing combustion and releasing carbon dioxide and other products, like nitrogen dioxide, as a result of this reaction. Chemicals released contribute to environmental issues like the enhanced greenhouse effect, pollution due to discarded polymers and increasing ocean acidity.



Prior knowledge



**FIGURE 10.1** Combustion of fuels, including alkanes, has increased production of carbon dioxide.

## 10.1 Using organic substances safely

In your high school laboratory studies, you will come across small amounts of organic substances that present some risks that are easily managed. In industry, large quantities of organic substances are used in a wide variety of manufacturing industries, presenting a challenge in the management of risk and safe use of these chemicals.

Products that are used in industry and around the home that can be dangerous include paints, lacquers, adhesives, degreasing materials, dry cleaning chemicals and printing materials.

These products contain common organic substances such as ethanal, propanone, pentyl acetate, benzene, tetrachloromethane, dichloromethane, ethanol and 1,2-ethanediol. Table 10.1 shows a selection of widely used organic solvents with their IUPAC name, common names and hazards.

The naming of organic compounds poses some difficulty since many industries and laboratories will use common names that often do not describe the chemical structure. For example, benzene is often known as coal naphtha or mineral naphtha. It is difficult from the name to identify the presence of benzene and thus take appropriate precautions with use and handling.

One method of reducing confusion over naming and thus safety precautions is the use of a **SDS (Safety Data Sheet)**. These give the official IUPAC name as well as other possible common names the chemical is known by.



The names of some hazardous but common substances are listed in Table 10.1.

**TABLE 10.1** Hazardous organic compounds

IUPAC NAME	OTHER COMMON NAMES	USES	HAZARDS
Ethanal	Acetaldehyde, acetic aldehyde, ethyl aldehyde	Polymer production, perfume production	Inhaled vapours are toxic. Long-term exposure can cause nervous system damage and pulmonary oedema. Short-term irritant to skin, eyes and mucous membranes.
Benzene	Coal naphtha, mineral naphtha, pyrobenzol	Production of plastics, resins, synthetic fibres, dyes, detergents, medicines and pesticides	Inhaled vapours are toxic. Long-term exposure can cause nervous system damage. Is an anaesthetic. Causes damage to blood components, anaemia and bleeding.
Propanone	Acetone, dimethyl ketone, methyl ketone, dimethylformaldehyde	Used as nail polish remover and paint thinner	Inhalation of vapours causes irritation to eyes, nose and throat. Not harmful if ingested.
Tetrachloromethane	Carbon tetrachloride, perchloromethane	Used in dry cleaning, as a degreaser, in fire extinguishers and as a pesticide	Toxic by inhalation, absorption or ingestion. Causes nervous system damage, irritates eyes and skin. Long-term skin contact causes dermatitis, and long-term liver and kidney damage.

All chemicals have SDS. They are available online, and are kept in all chemical laboratories and manufacturing or industrial sites that use chemicals. Each SDS details the properties of a particular chemical, identifies possible hazards and precautions for safe use and handling, as well as steps to be taken to administer first aid upon contact, inhalation or ingestion.

Another method of preventing accidental contact with hazardous chemicals is correct labelling. Correct labelling procedures are covered by local regulations but should clearly indicate the name, concentration and possible hazards of the chemical. Examples of chemical labels are seen in Figure 10.2.



**FIGURE 10.2** Labels for organic chemicals

## INVESTIGATION 10.1



Information and  
communication  
technology  
capability

### SDS and chemical labelling

#### AIM

To find and analyse SDS information and to examine labelling on chemical containers.

#### MATERIALS

- At least five SDS for commonly used laboratory chemicals. Suggestions include ethanol, cyclohexane, bromine, benzene and concentrated sulfuric acid. Identify some other chemicals you use on a regular basis and include those as well. **Note:** Your teacher may supply the SDS, otherwise they are easily searchable on the Internet.
- Various containers of chemicals. Not to be opened or used during this investigation. Alternately, your laboratory staff can provide examples of labels used on chemical storage bottles.

#### METHOD

The following can be done individually or in small groups.

- Print copies of five SDS, including at least three organic compounds.
- Compare the sections/headings used, explaining why each section has been included.
- Compare the information provided on managing risks and providing first aid to the facilities available in your laboratory. Identify the safety equipment/facilities available to you that allow you to deal with possible issues.
- Using information from the SDS, suggest reasons why some chemicals are:
  - for teacher use and teacher demonstration only
  - not allowed to be used in schools.
- Many students write up their risk assessment after completing an investigation. Explain the purpose of doing a risk assessment *prior* to undertaking a practical investigation.
- Examine the common features of the labels used on various chemicals.
- Identify and explain the meaning of the warning symbols on the label.
- Explain how these labels can help to avoid accidental exposure to chemicals.

#### CONCLUSION

Write a conclusion about the importance of understanding and using SDS and chemical labelling.

### Risks of organic chemicals related to physical properties

The physical properties of organic compounds lead to particular hazards. Knowledge of the properties allows chemists to identify safe ways to use the substance.

Many organic compounds are **volatile**. They have weak intermolecular forces and often evaporate at room temperature to form a vapour. This vapour can be less dense than air and will rise and fill the room or can be dense and will settle at lower levels. Vapours of organic compounds are usually colourless and thus not easily seen; however, almost all have pungent smells so can be detected.

Most organic compounds are highly flammable, especially when in vapour form. This is related to a property called **flashpoint**: the lowest temperature at which a liquid can form an ignitable mixture in air

near the surface of the liquid. The lower the flashpoint, the easier it is to ignite. Any organic substance with a flashpoint below 23°C is considered to be highly flammable. Chemicals with flashpoints below this include cyclohexane, cyclohexene, ethanol, propanone, pentane, propanol and methanol.

Many organic compounds are also often highly reactive so will react with substances in the air, water, or other nearby chemicals.

## Exposure methods and effects

There are three ways that an organic compound can enter the body.

- 1 Inhalation through the lungs. This is the most common method since vapours are the easiest way to come in contact with a chemical, and therefore, the gas is able to be breathed in. The organic compound will dissolve into the bloodstream through the walls of the lungs and travel around the body to various internal organs where it will build up over time.
- 2 Absorption through the skin. This is less common, but has the same mechanism. The compounds dissolve through the skin and make their way into the bloodstream.
- 3 Ingestion (swallowing). This is usually done accidentally when chemicals remain on the hands or clothes and then later ingested along with food or drinks.

The effects of contact with organic compounds vary with length of exposure, type of chemical and the health of the person.

Contact effects (absorption) causes the solvent to dissolve fats in human skin and remove the protective barrier that would normally exist. This allows chemicals to more easily enter the bloodstream. Symptoms of skin contact include a burning or tingling sensation on the skin, the presence of welts or rashes, or chemical burns (similar to burns from a heat source or flame).

Acute poisoning can occur immediately upon contact or symptoms can develop within a few hours. This often occurs upon exposure to organic vapours. A subject can develop headaches, dizziness, have their reaction time or vision affected, suffer from poor coordination and possibly lose consciousness.

Chronic poisoning occurs after repeated exposure, often over years or decades. This is found in industries where people are exposed to chemicals on a daily basis. Symptoms can include chronic fatigue, physical weakness, mood changes, liver and kidney damage, and damage to the central nervous system.

## Prevention methods

Various methods are used in laboratories and in industry to prevent or minimise exposure to organic compounds.

Many industries have moved to eliminate or substitute harmful chemicals. Alternative, less toxic chemicals have replaced substances like benzene. Benzene was used for years with little protection for its users.

Long-term effects of benzene include:

- ▶ damage to bone marrow cells, resulting in anaemia and blood disorders
- ▶ immune system disorders where the white blood cells are destroyed and antibodies are produced at much lower levels than normal
- ▶ effects on the unborn foetus, causing birth defects and premature births.

Benzene has been phased out of many industries, and in products like paints and glues. Alternative products, such as cyclohexane, are now used in processes like electroplating, rubber manufacture and chemical production.

Isolation is another method used to prevent people from chemical contact. As seen in Figure 10.3 (page 294), physical separation from chemicals via a container, or use of automated systems reduces exposure significantly. Simple isolation includes use of a lab coat, safety glasses and gloves to avoid contact and possible absorption of chemicals through the skin.



**FIGURE 10.3** A chemist working in a containment system to isolate the chemical vapours



**FIGURE 10.4** A chemist working in a fume cupboard to avoid chemical vapour exposure



Safety with hydrocarbons

A method you have probably used is ventilation or fume extraction. On a small scale, a fume cupboard, seen in Figure 10.4, is a ventilation system that uses fans to draw fumes upwards and away from the user. On an industrial scale, giant extractor systems clear rooms and factories of vapours and reduce the chance of chemical inhalation.

## Disposal of organic compounds

Disposal of organic compounds is strictly governed by legislation in Australia. In both the laboratory and industry contexts, waste is collected and then dealt with by specific chemical waste disposal companies. Often waste is treated first to remove acids or bases (by simple neutralisation), or filtered to remove metal solids or other solid materials.

Different types of waste are often kept separate; for example, halogen-based organic substances are often collected separately to simple hydrocarbon or alcohol/aldehyde waste. Since they pose different hazards and risks, they are treated separately, using different chemical methods to reduce the risk of these compounds affecting the environment.

The largest consideration when dealing with chemical waste is what can be washed down the sink and what cannot. As a general rule, no organic waste should be washed down the sink, no matter how dilute. These chemicals end up in the sewage system, and eventually in our river systems. The toxic nature of these chemicals results in poisoning of plants, animals and humans who use these waterways.

In your classroom, there should always be a waste container when dealing with organic chemicals. Ensure that you empty all organic waste into this container. This is also the reason why practical investigations involving organic

substances use very small amounts. Reduction of the volume of waste is key, so you should always use as small a volume as possible when conducting practical investigations in any chemical experiment, but specifically when using organic materials.

- SDS (Safety Data Sheets) are used to ensure common understanding of chemical names, identify and minimise hazards, and provide first aid information.
- Labelling of chemicals is governed by legislation and to minimise accidental contact with chemicals.
- Physical properties of organic chemicals like volatility, flammability and reactivity allow for identification of risks.
- Exposure to organic chemicals occurs through inhalation, absorption or ingestion.
- Effects of exposure can be minor, or can result in acute poisoning (immediate symptoms) or chronic poisoning (long-term symptoms).
- Elimination or substitution of chemicals, isolation (including use of personal protective equipment) and proper ventilation/extraction are used to minimise risks of chemical use.
- Disposal of organic chemicals is governed by legislation and involves collection and treatment of different classes of substances.



- 1 Identify three commonly used organic chemicals by their IUPAC and common names.
- 2 Identify what features you should see on a chemical label.
- 3 Explain how using a SDS:
  - a reduces confusion about chemicals
  - b reduces risk in using chemicals.
- 4 Describe three physical properties of organic substances that pose a risk in the use of those chemicals.
- 5 Explain the difference between contact effects, acute poisoning and chronic poisoning. Include common symptoms of each.
- 6 Explain three methods of minimising or preventing risks when using organic substances.
- 7 In your studies you will be asked to use various organic compounds.
  - a Identify three possible risks of using organic compounds.
  - b For each risk you have identified, suggest a precaution you can take in a school laboratory to minimise risk.
- 8 Explain why you have an organic waste container during practical investigations involving organic compounds.
- 9 Table 10.2 below shows some organic chemicals and their flashpoints.

**TABLE 10.2** Flashpoints of some organic chemicals

ORGANIC CHEMICAL AND FORMULA	FLASHPOINT (°C)
Ethanoic acid (C <sub>2</sub> H <sub>4</sub> O <sub>2</sub> )	39
Propanone (C <sub>3</sub> H <sub>6</sub> O)	-20
1-butanol (C <sub>4</sub> H <sub>10</sub> O)	37
Ethanol (C <sub>2</sub> H <sub>6</sub> O)	13
Hexane (C <sub>6</sub> H <sub>14</sub> )	-22

Suggest a reason related to managing risk that:

- a 1-butanol should be used when testing alcohols rather than ethanol
- b hexane should always be used in a fume cupboard where possible, while ethanoic acid can be used outside the fume cupboard.

## 10.2

# Unsaturated hydrocarbon reactions

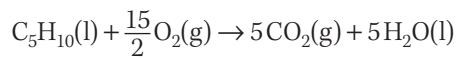
Alkenes and alkynes are highly reactive due to the presence of the double bond (alkene) or triple bond (alkyne). The double and triple bonds in alkenes and alkynes have a different structure from the single C—C bonds in alkanes. The double and triple bonds are weaker, easier to break and thus result in the higher reactivity of molecules containing these bonds.

### Combustion reactions

Both alkenes and alkynes undergo combustion reactions. Combustion reactions occur when substances are burnt in the presence of oxygen, releasing large amounts of energy. This energy is often harnessed to power internal combustion engines, industrial furnaces, or domestically for heating or cooking.

Combustion can be complete or incomplete depending upon the amount of oxygen available. Incomplete combustion will be discussed in detail later in this chapter.

Complete combustion of hydrocarbons (both alkenes and alkynes) produces carbon dioxide and water, as seen with 1-pentene:



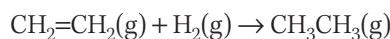
## Addition reactions

Alkenes and alkynes undergo reactions that add atoms to the compound by breaking the double or triple bond. This type of reaction is called an **addition reaction**.

In an addition reaction, substances such as hydrogen ( $\text{H}_2$ ), water ( $\text{H}_2\text{O}$ ), hydrogen halides ( $\text{HX}$ ) or halogens ( $\text{X}_2$ ) are reacted with an alkene or alkyne and all of the atoms of the molecule are added to the alkene/alkyne structure. No atoms are left over in an addition reaction.

## Addition of hydrogen

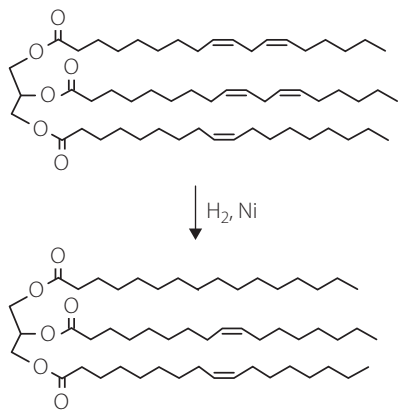
One common addition reaction of both compounds is addition of hydrogen, in a reaction known as **hydrogenation**. Alkenes are converted to alkanes in this reaction, as seen with ethene forming ethane below:



The addition of hydrogen to an alkene occurs in the presence of a metal **catalyst** such as nickel, platinum, palladium or rhodium. The catalyst is necessary since the hydrogenation reaction is quite slow. The overall reaction involving the catalyst takes place as follows.

- 1 The hydrogen molecule reacts with the metal catalyst breaking the bond between the two hydrogen atoms, forming two weak metal–hydrogen bonds.
- 2 The alkene molecule reacts with the metal catalyst, breaking one of the bonds in the alkene double bond, forming weak carbon–metal bonds.
- 3 The metal catalyst causes the hydrogen atoms to join to the carbon atoms, creating the final alkane molecule.

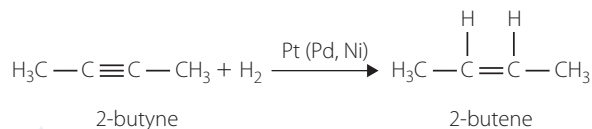
Hydrogenation of alkenes is used to make margarine from edible liquid oils. Margarine is a solid fat. Fats and oils are natural esters (discussed in chapter 12). Both fats and oils contain long chain hydrocarbons. Fats contain primarily saturated hydrocarbon chains whereas, oils contain unsaturated chains, with one or multiple double bonds. This is the meaning of terms you may have heard like ‘saturated fats’ or ‘**polyunsaturated**’ margarine/oils.



**FIGURE 10.5** Hydrogenation of a liquid unsaturated oil to make a more saturated molecule like margarine

To make margarine, liquid oils containing double bonds have hydrogen gas added, in the presence of heat and a nickel catalyst. Sufficient hydrogen is added so the oil becomes a solid at room temperature, but not enough to fully saturate the entire molecule. This process is seen in Figure 10.5.

An alkyne can be converted into an alkene, as seen in Figure 10.6 where 2-butyne is converted to 2-butene. To prevent the alkene reacting to form an alkane, a Lindlar catalyst is used. This is a heterogeneous catalyst consisting of palladium deposited on calcium carbonate. The catalyst acts as an **inhibitor**, preventing the alkene from reacting further to an alkane.

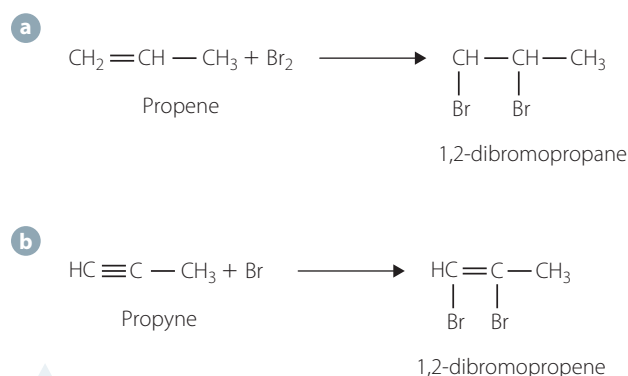


**FIGURE 10.6** Reaction of 2-butyne to form 2-butene with a Lindlar catalyst

## Addition of halogens

In a similar mechanism to the addition of hydrogen, halogen atoms like chlorine or bromine can be added across a double or triple bond. This is known as **halogenation**. Figure 10.7a shows the addition of bromine to propene to form 1,2-dibromopropane. Figure 10.7b shows the addition of bromine to propyne, forming 1,2-dibromopropene. This can go on to add bromine again, breaking the double bond and forming 1,1,2,2-dibromopropane.

Due to the reactivity of the halogens, a catalyst is not needed for this reaction to occur.



**FIGURE 10.7** Addition of bromine to **a** propene and **b** propyne

## Addition of hydrogen halides

**Hydrogen halides** are molecules with a hydrogen atom and a halogen atom like chlorine or bromine. Hydrogen chloride and hydrogen bromide are common hydrogen halides. Figure 10.8 shows the addition of hydrogen chloride to ethyne (alkyne) and chloroethene (alkene). The hydrogen halide adds across the double/triple bond, with the hydrogen attaching to one of the carbons originally in the double/triple bond, and the halogen attaching to the other carbon in the original double/triple bond.

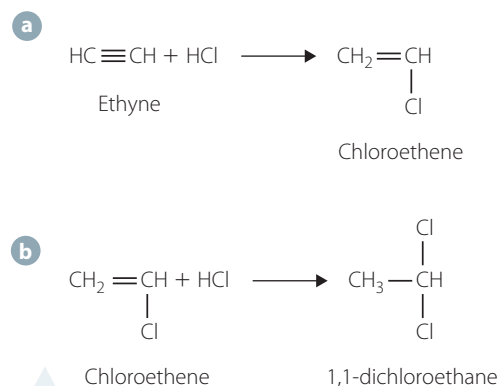
## Addition of water

To add water to an alkene, a dilute sulfuric acid catalyst is required. When water is added across a double bond, one of the hydrogens from the water molecule attaches to one carbon originally in the double bond, the remaining  $-\text{OH}$  attaches to the other carbon. Figure 10.9 shows the addition of water to ethene to form ethanol.

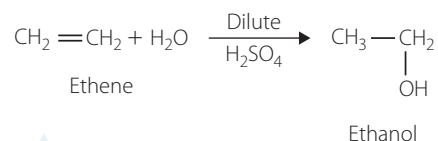
The production of ethanol in this way is of significant industrial importance. While alcohol that is used for beverages is almost exclusively produced by fermentation, the industrial quantities required cannot be produced using fermentation alone.

Ethanol has many uses in industry including as a solvent, an antiseptic and disinfectant, in the synthesis of multiple organic products and polymers (see chapter 13) and as a biofuel (see chapter 12).

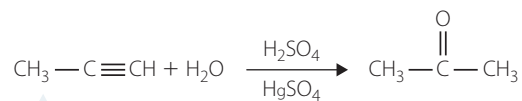
The hydration of alkynes is catalysed by mercury(II) compounds and sulfuric acid. Addition of water to an alkyne will produce a ketone, as seen in Figure 10.10. The exception is hydration of ethyne that produces ethanal since a ketone cannot form with only two carbons in the chain.



**FIGURE 10.8** Addition of hydrogen chloride to **a** ethyne and **b** chloroethene



**FIGURE 10.9** Addition of water to ethene to form ethanol



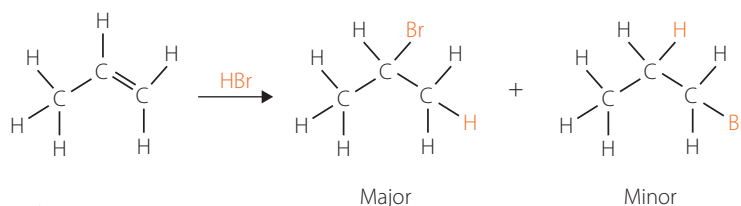
**FIGURE 10.10** Addition of water to propyne to form propanone

## General notes on addition reactions

The following points should be noted about all addition reactions.

- ▶ When a symmetrical reagent (for example  $\text{H}_2$  and  $\text{Cl}_2$ ) is added, the product of the reaction has the same group added to each carbon.
- ▶ When an asymmetrical reagent (for example  $\text{H}_2\text{O}$  or  $\text{HBr}$ ) is added to a symmetrical alkene, there is only one possible product.
- ▶ When an asymmetrical reagent (for example  $\text{H}_2\text{O}$  or  $\text{HBr}$ ) is added to an asymmetrical alkene, there are two possible products. In reality, one product predominates, as explained by **Markovnikov's rule**, which states that the hydrogen atom will predominantly add across the double bond to the carbon that already has the greater number of hydrogen atoms, creating a major and a minor product. This can be seen in Figure 10.11 (page 298).





**FIGURE 10.11** Markovnikov's rule – the hydrogen adds to the end carbon since it has the greater number of hydrogens attached.

## Polymerisation

Alkenes and alkynes are extensively used in addition polymerisation reactions where multiple alkenes/alkynes are added together to form a long chain polymer. You will learn more about polymerisation in chapter 13.

## INVESTIGATION 10.2



Information and communication technology capability

### Modelling reactions of unsaturated hydrocarbons (Part 1)

#### AIM

To model the reactions of alkenes and alkynes.

#### MATERIALS

- Organic model kits if no kits are available, use modelling clay in various colours to represent carbon, hydrogen, oxygen and various halogen atoms and toothpicks to represent bonds)
- Digital camera



#### WHAT ARE THE RISKS IN DOING THIS INVESTIGATION?

Possible risk of slipping on model kit components if they are on the floor.

#### HOW CAN YOU MANAGE THESE RISKS TO STAY SAFE?

Keep all components within the containers provided if not being used.

What other risks are associated with your investigation? How can you manage these?

#### METHOD

##### PART A: MODELLING HYDROGENATION (ADDITION OF HYDROGEN)

Make models of ethene and hydrogen. Take photos of the 'reactants'. Combine the two models to make the product. Take photos (or sketch drawings) of the 'product'. Repeat for two other simple alkenes.

##### PART B: MODELLING THE ADDITION OF HYDROGEN HALIDES, HALOGENS AND WATER

Repeat the process above to model the addition of each of hydrogen halides, halogens and water to at least two simple alkenes. Take photos of your 'reactants' and 'products'.

#### DISCUSSION

##### PART A

- Write equations for each of the three reactions you modelled, naming all reactants and products.
- Identify a benefit of using modelling to improve your understanding.

- 3 Identify a specific limitation of modelling this type of reaction. (What does it not show/represent properly?)
- 4 Explain what you would do differently to model the addition of hydrogen to an alkyne like ethyne.

#### PART B

- 1 Identify two reactions you have modelled that are addition reactions. Use the photos you have taken to explain what is meant by an addition reaction.
- 2 Using a model of the reaction between propene and water, explain why two different products are possible from some addition reactions.

- Alkenes and alkynes undergo combustion reactions, producing carbon dioxide and water.
- Addition reactions in alkenes and alkynes occur when atoms add by breaking a double or triple bond
- Addition of hydrogen, halogens, hydrogen halides and water occurs for both alkanes and alkenes
- Many addition reactions involve the use of a catalyst to speed up the reaction.

- 1 Write balanced equations for each of the following.
  - a The combustion of 1-pentyne
  - b The reaction of ethene with chlorine gas
  - c The reaction of 2-butene with water
  - d The reaction of ethyne with bromine
- 2 Explain how a metal catalyst works in the reaction converting an alkene to an alkane.
- 3
  - a Describe the conversion of liquid oils to margarine.
  - b Describe the importance of the production of ethanol from ethene.
- 4 Explain why the addition of a hydrogen halide to propyne is considered a two-step process. Write equations to represent each step.
- 5 Write an equation to represent the addition of water to 1-butene and explain why there are two possible products. Explain which product is more likely to form.
- 6 Compare the addition of water to alkenes and alkynes.

#### CHECK YOUR UNDERSTANDING

10.2

## 10.3 Saturated hydrocarbon reactions

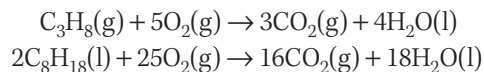
Alkanes do not react with most substances due to a lack of reactive group like the double or triple bonds of alkenes and alkynes.

They have two important reactions: combustion and **substitution**.

### Combustion of alkanes

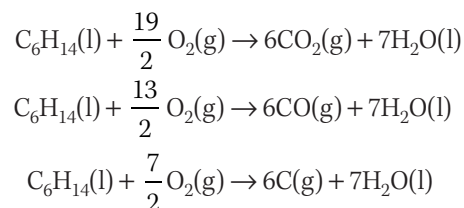
Like alkenes and alkynes, the alkanes undergo combustion reactions when in a plentiful supply of oxygen, producing carbon dioxide and water. Large amounts of heat are produced, making them ideal for use as a fuel.

Complete combustion occurs when oxygen is present in excess:



In many situations, including furnaces and internal combustion engines, oxygen is not present in excess amounts. Under conditions of limited oxygen, **incomplete combustion** occurs. Incomplete combustion results in other products being formed such as carbon monoxide and carbon (soot). Depending on the amount of oxygen available, products can include a mixture of carbon dioxide, carbon monoxide and carbon. Incomplete combustion can also occur for alkenes, alkynes, alcohols and other organic compounds.

The equations below compare the combustion of hexane with excess and limited oxygen:



The enthalpy of combustion values for each of the above reactions decrease as the levels of oxygen available decrease. Complete combustion of hexane releases around  $4000\text{ kJ mol}^{-1}$ , while the incomplete combustion of hexane producing carbon (third equation above) releases less than  $2000\text{ kJ mol}^{-1}$ .

Therefore, incomplete combustion releases less energy per mole of organic compound than complete combustion. This makes fuel combustion less efficient. In cars, part of a regular service involves ensuring as much air as possible can enter the combustion chamber to encourage complete combustion to occur.

The release of carbon dioxide will be discussed later in this chapter, but issues exist with releasing carbon monoxide and carbon as well.

Carbon monoxide impacts on human health at levels above 10 ppm. Effects can include impaired judgement, headaches, dizziness and altered visual perception at lower levels. Higher levels, above 250 ppm, can result in loss of consciousness and death. Normally, oxygen molecules bind to a protein in the blood called haemoglobin, forming an equilibrium that ensures oxygen levels in the body remain at sufficient levels for respiration to occur in cells. The carbon monoxide molecule replaces oxygen in this process, so cells are unable to function normally. Carbon monoxide levels in cities during peak hour traffic can reach 50–100 ppm, far above levels that are safe.

Carbon particles are also known as soot. They are crystalline particles that are small enough to be breathed in by animals. These particles can coat the lungs, decreasing the ability of the body to take in oxygen, and thus, impairing respiration. The soot particles also have molecules of fuel and other toxic substances bonded to the surface. These act as a toxin inside the body when inhaled along with the soot.

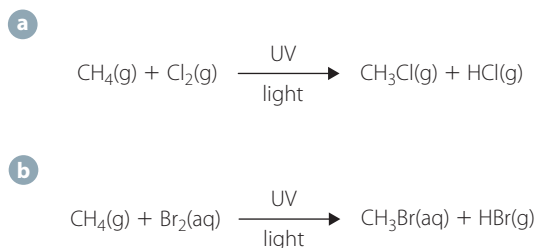
## Substitution with halogens

In a substitution reaction, an atom of another element substitutes for a hydrogen atom. This reaction usually only occurs with chlorine or bromine and it will not occur unless sufficient amounts of energy are supplied. This reaction will only occur if the mixture is subjected to UV light.

In the presence of UV light, methane will have one of its hydrogen atoms replaced by chlorine, forming chloromethane and hydrogen chloride, as seen in Figure 10.12a.

Under the same conditions, methane will also react with bromine to form bromomethane and hydrogen bromide, as seen in Figure 10.12b.

Substitution reactions can continue until all the hydrogen atoms in the compound have been replaced by halogen atoms. This occurs with only one halogen atom being substituted at a time. If four halogen atoms are to be added, then four reactions would need to occur. For example, methane would eventually form tetrachloromethane or tetrabromomethane after four separate substitution reactions.



**FIGURE 10.12** Addition of chlorine and bromine to methane under UV light

## INVESTIGATION 10.3

### Modelling reactions of unsaturated hydrocarbons (Part 2)

#### AIM

To model substitution reactions of alkanes.

#### MATERIALS

- Organic model kits (if no kits are available, use modelling clay in various colours to represent carbon, hydrogen, oxygen and various halogen atoms and toothpicks to represent bonds)
- Digital camera

#### WHAT ARE THE RISKS IN DOING THIS INVESTIGATION?

Possible risk of slipping on model kit components if they are on the floor

#### HOW CAN YOU MANAGE THESE RISKS TO STAY SAFE?

Keep all components within the containers provided if not being used.



What other risks are associated with your investigation? How can you manage these?

#### METHOD

- 1 Modelling substitution of halogens:
  - a Make a molecule of methane and several molecules of either chlorine ( $\text{Cl}_2$ ) or bromine ( $\text{Br}_2$ ).
  - b Take photos of a methane and a halogen model as your 'reactants'.
  - c Predict and make the products of this reaction. Take photos as your 'products'.
  - d Continue with this process until you have created the final product of this series of substitution reactions.

#### DISCUSSION

- 1 Identify why the reactions you have modelled are substitution reactions. Use the photos you have taken to explain what is meant by a substitution reaction.
- 2 Identify how many reactions occurred between the reactant methane and the final product.
- 3 Write a series of equations to represent the reactions that occurred, naming the product of each reaction.
- 4 Identify a significant limitation of modelling this process.

## INVESTIGATION 10.4

### Comparing reactivities of alkanes and alkenes

#### AIM

Write a suitable aim for this investigation.

#### MATERIALS

- 3 mL samples of alkanes and alkenes: hexane, cyclohexane and cyclohexene (or similar – should be in liquid form)
- 4 mL of 0.01 mol L<sup>-1</sup> potassium permanganate (KMnO<sub>4</sub>) solution
- 6 mL bromine water (Br<sub>2</sub>)
- 2 mL of 2.0 mol L<sup>-1</sup> sulfuric acid (H<sub>2</sub>SO<sub>4</sub>)
- Deionised water
- 4 test tubes and a test-tube rack
- 4 disposable droppers
- 5 mL measuring cylinder
- Gloves



WHAT ARE THE RISKS IN DOING THIS INVESTIGATION?	HOW CAN YOU MANAGE THESE RISKS TO STAY SAFE?
Cyclohexane and cyclohexene are toxic.	Avoid contact with skin and inhalation of vapours. Wear gloves and a lab coat. Use in a fume cupboard. Wash your hands at the end of the experiment.
Bromine water is poisonous and corrosive.	Avoid contact with skin and inhalation of vapours. Wear gloves and a lab coat. Use in a fume cupboard. Wash your hands at the end of the experiment.
Sulfuric acid is corrosive.	Wear gloves and a lab coat. Avoid contact with skin. Wash your hands at the end of the experiment.
Hexane, cyclohexane and cyclohexene are highly flammable.	Ensure no flame sources are present near any of these chemicals.

What other risks are associated with your investigation? How can you manage these?

#### METHOD

##### PART A: OXIDATION REACTIONS WITH ACIDIFIED KMnO<sub>4</sub> SOLUTION

Potassium permanganate is a strong oxidising agent so may cause the hydrocarbon to oxidise. A positive reaction indicates that the hydrocarbon has oxidised.

- Label three test tubes, one for each hydrocarbon.
- Place 1 mL of each hydrocarbon into the corresponding test tube.
- In a clean test tube, mix 4 mL of KMnO<sub>4</sub> solution and 2 mL of H<sub>2</sub>SO<sub>4</sub>.
- Add 1 mL of the KMnO<sub>4</sub>/H<sub>2</sub>SO<sub>4</sub> solution to each of the test tubes containing the hydrocarbons.
- Shake gently and observe for 5 minutes.
- Dispose of the solutions in a chemical waste jar as directed by your teacher. Do not pour down the sink.
- Rinse the test tubes and droppers with deionised water.

##### PART B: ADDITION AND SUBSTITUTION REACTIONS WITH BROMINE

- Place 1 mL of each hydrocarbon into a clean, labelled test tube.
- Add 1 mL of Br<sub>2</sub> to each test tube.
- Shake gently and observe for 5 minutes.
- If a change is noted, add another 1 mL of Br<sub>2</sub> to that test tube and observe.
- Dispose of the solutions in a chemical waste jar as directed by your teacher. Do not pour down the sink.

## RESULTS

Record your observations/results in a suitable table. You should include observations of the hydrocarbons before and after adding the  $\text{KMnO}_4$  and  $\text{Br}_2$ .

## DISCUSSION

- 1 Potassium permanganate is a strong oxidising agent.
  - a Explain what this means.
  - b Explain which hydrocarbons were readily oxidised by the  $\text{KMnO}_4$  solution.
- 2 Which of the hydrocarbons reacted with the  $\text{Br}_2$  solution? Explain whether your results are expected.
- 3 How would you modify the investigation so all hydrocarbons showed a positive reaction with  $\text{Br}_2$ ?
- 4 Write equations for the reactions that occurred in part B.

## CONCLUSION

With reference to the observations made and analysis, write a conclusion about the relative reactivities of alkanes and alkenes.

- Alkanes, alkenes and alkynes all undergo combustion reactions in excess oxygen, or incomplete combustion under conditions of limited oxygen.
- Incomplete combustion produces carbon monoxide and soot, both of which have harmful effects on human health.
- Alkanes undergo halogen substitution reactions in the presence of UV light, creating haloalkanes.

- 1 Identify the key difference between halogen reaction with alkanes and alkenes.
- 2 Distinguish, using examples, between substitution and addition reactions.
- 3 Compare complete and incomplete combustion in terms of products and energy released.
- 4 Write balanced equations for:
  - a the complete combustion of pentane
  - b the reaction of butane with chlorine gas under UV light
  - c the stepwise reaction of methane with chlorine gas until the molecule is fully substituted.
- 5 Write an equation to show the complete and incomplete combustion of butane.
- 6 Describe possible negative consequences of incomplete combustion.
- 7 A certain gaseous hydrocarbon is bubbled through bromine water. The bromine is not decolourised. Explain what you can conclude about the unknown hydrocarbon.

## CHECK YOUR UNDERSTANDING

10.3

## 10.4

# Implications of obtaining and using hydrocarbons

The hydrocarbons we use on a daily basis come in many forms. We use polymers, including plastics and fibres in our clothes, furniture, containers and electronics. We use hydrocarbon-based fuel through gas cooking, heating or as automobile fuel. We use many products containing organic substances that have their origins in simple alkanes, alkenes and alkynes. Paints, adhesives, solvents, medicines and cosmetics all have connections to the hydrocarbons you have already studied.

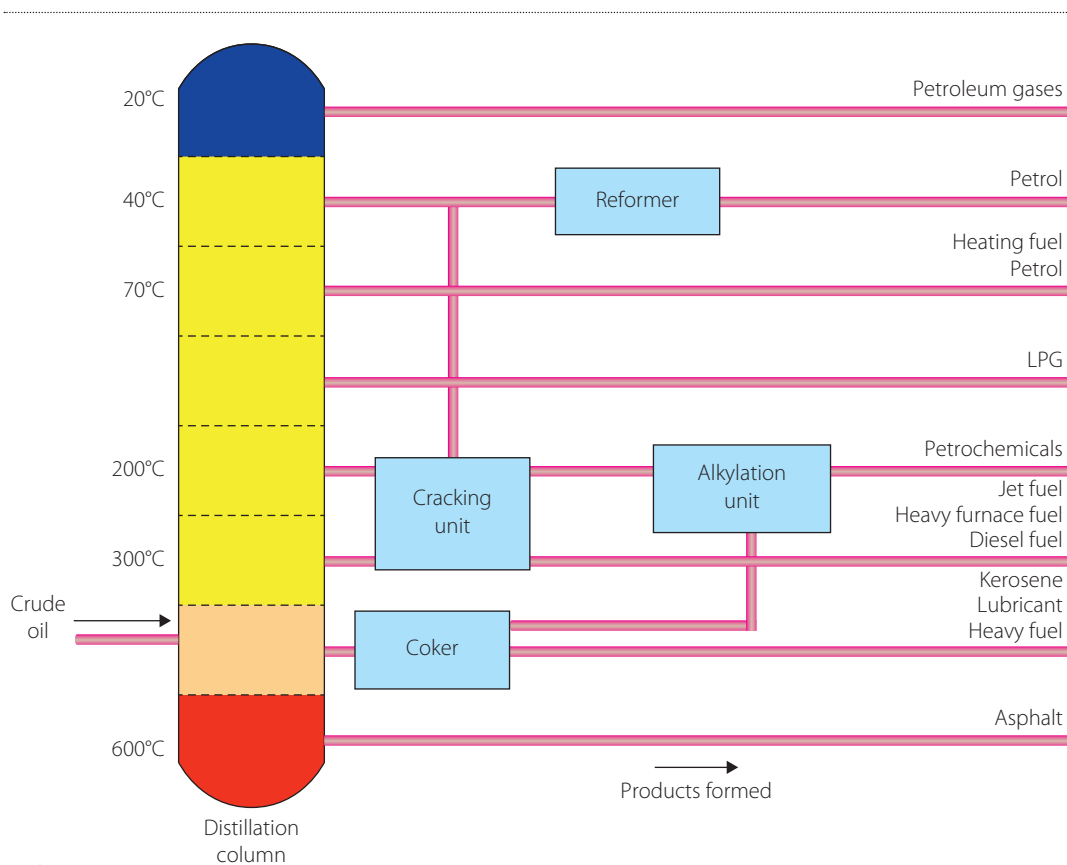


The primary source of these hydrocarbons is from **crude oil**, a fossil fuel formed by the decomposition of prehistoric living organisms. Crude oil takes millions of years to form.

Crude oil is a mixture of hydrocarbons, and is processed using **fractional distillation**. Fractional distillation separates substances with different boiling points. The crude oil is boiled at the bottom of the tower. The gases then rise up the fractionating column, which decreases in temperature towards the top of the tower. As each fraction reaches the part of the tower that matches its boiling point, it condenses in trays and is collected.

Fractions with higher boiling points are condensed at lower levels of the fractionating tower, while the low boiling point gases rise to the top and remain in gaseous form.

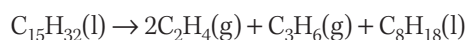
Oil refineries make the processing of crude oil economically viable and efficient. The crude oil is heated at normal atmospheric pressure to about 400°C in the distillation column (Figure 10.13), which has multiple exit points for the condensed substances. Crude oil is continuously fed into the distillation column, which allows for a continuous process.



**FIGURE 10.13** Distillation column in an oil refinery

Most fuels are not refined any further. However, some of the heavier fractions are processed further to increase the yields of the lighter fractions, which are the fractions in highest demand.

In Australia, some of the heavier fractions that have carbon chains with 15–25 carbon atoms undergo **catalytic cracking**. Catalytic cracking is an example of a decomposition reaction where larger molecules are broken down into smaller molecules. This process uses a catalyst, a temperature of about 500°C and a moderately low pressure. The catalysts are **zeolites** (aluminosilicates), which are compounds containing aluminium, silicon and oxygen. An example of a catalytic cracking reaction is:





In this reaction, pentadecane ( $C_{15}H_{32}$ ) is broken down into shorter alkanes like octane ( $C_8H_{18}$ ) and alkenes like ethene ( $C_2H_4$ ) and propene ( $C_3H_6$ ). Octane is used primarily as automobile fuel, while ethene and propene are common feedstocks for polymer and chemical production.

**Thermal cracking** is also used to create more desired organic products. In thermal cracking, high temperatures, in the range of  $450^\circ\text{C}$  to around  $750^\circ\text{C}$ , and pressures of 70 atmospheres are used to break down the large, unwanted hydrocarbons into more useful products as described above. The reactions for thermal cracking and catalytic cracking are often the same, but the mechanism of the reaction is different.

## Mining and transporting crude oil and natural gas

Mining for crude oil and **natural gas** is often ocean-based since the sedimentation that occurred there over millions of years is ideal for formation of fossil fuels. Natural gas is a mixture of simple alkanes – mostly methane, but with small amounts of ethane, propane, butane and pentane. Crude oil is also mined on land, sometimes in remote areas of environmental significance. There has long been controversy over mining in Alaska and the Arctic and Antarctic regions and the potential environmental impact the mining and transport of oil and gas may bring.

One significant example of this was the Exxon Valdez oil spill in 1989 that caused significant environmental damage in Prince William Sound in Alaska when an oil tanker ran aground. Around 41 million litres of oil was spilt, contaminating over 1800km of coastline, causing massive short-term damage to plants, animals and the local environment. Figure 10.14 shows workers in protective suits cleaning up crude oil that has washed ashore. In the weeks after the spill there were four human deaths. The following animal deaths were also recorded:

- ▶ 140 eagles
- ▶ 300 seals
- ▶ 3000 sea otters
- ▶ over 250000 sea birds.

There were also long-term effects on the local economy due to poisoning and depletion of fish stocks, and lasting consequences for the animal life in the area with disruption to breeding, hunting and the homes of many species. It is estimated that:

- ▶ 26000 jobs were lost in the tourism industry
- ▶ 10000 jobs were lost or affected in and around the fishing industry
- ▶ \$2.4 billion of income from fishing and tourism was lost.

When incidents like this occur there are also significant sociocultural effects including psychological stress due to job loss, mortgage stress, and legal action related to compensation from the effects of the disaster.

A more recent example is the Deepwater Horizon, which exploded in April 2010, killing 11 people and causing the largest oil spill in US history. Like the Exxon Valdez, this incident has had long-term effects on the environment with animal and plant life severely affected for several years after the event. There is also significant economic and social harm from these events with many locals forced to give up their fishing, seafood and tourist businesses due to pollution and a downturn in people visiting the area. It is estimated that thousands of people ended up out of work for years after this event, placing stress on welfare systems and the local communities to provide support for these people and their families.



**FIGURE 10.14** The consequences of an oil spill can be severe, both in terms of environment and economy.

It is estimated that thousands of people ended up out of work for years after this event, placing stress on welfare systems and the local communities to provide support for these people and their families.

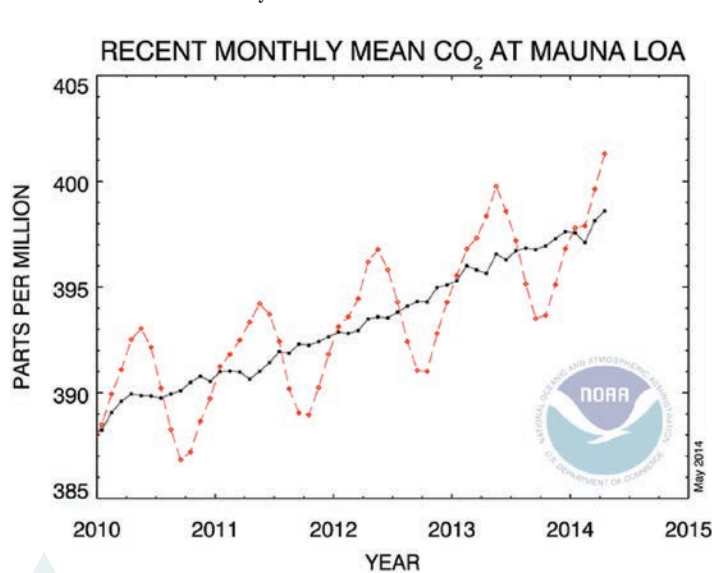
There are many locations in the world where shipping passes through areas of significant environmental importance. Oil spills in these areas can have massive ecological impacts. In July 2015, the tanker *Regina* ran around in the Great Barrier Reef Marine Park off the coast of Queensland. 15 tonnes of oil reached the Australian mainland and cost several million dollars to clean up. While there was limited environmental damage in this case, there is the potential for much more damage, as seen in the Exxon Valdez and Deepwater Horizon examples.

## The greenhouse effect

As discussed earlier, one of the primary uses of organic compounds is as a fuel. Octane and ethanol are used as automobile fuels, methane and ethane are used domestically for heating and cooking, and butane is used in BBQ gas bottles for cooking.

Carbon dioxide produced through the combustion of these fuels is a greenhouse gas, so it absorbs infrared radiation in the atmosphere. Carbon dioxide produced through fossil fuel combustion is a major contributor to the **enhanced greenhouse effect**.

The increase in carbon dioxide in the atmosphere in the last 50 years is undeniable. Measurements taken by the US National Oceanic and Atmospheric Administration (NOAA) at the Mauna Loa Observatory in Hawaii show a steady increase in the amount of carbon dioxide in the atmosphere, seen in Figure 10.15. The extra CO<sub>2</sub> is being released into the atmosphere after being locked away in coal reserves for millions of years. Life on Earth has evolved in an atmosphere that does not include this CO<sub>2</sub>.



**FIGURE 10.15** Concentrations of carbon dioxide measured in Hawaii by NOAA

Carbon dioxide absorbs **infrared radiation**, so this increase in carbon dioxide means an increase in the amount of heat that is trapped in the atmosphere. The most obvious consequence of this extra heat is a rise in global temperature.

The Intergovernmental Panel on Climate Change (IPCC) is an international body developed in 1988 to provide a clear, scientific view on climate change. It is open to all member countries of the United Nations (UN) and the World Meteorological Organisation. The IPCC provides rigorous and balanced scientific information to decision-makers.

This level of knowledge is respected due to the range of scientists contributing and the review process of their contributions.

In 1992, Australia and 150 other countries signed the United Nations Framework Convention on Climate Change at the United Nations Conference on Environment and Development held in Rio de Janeiro, Brazil. The countries identified the importance of working to find solutions to the emission of greenhouse gases to reduce climate change. This commitment was extended in 1997 with the Kyoto Protocol, an international agreement to setting emission reduction targets. The first commitment period from 2008 to 2012 saw 37 industrialised countries commit to reducing greenhouse gas emissions to an average of 5 per cent below 1990 levels. This was amended for the second commitment period from 2013 to 2020 to 18 per cent below 1990 levels.

## Consequences of the enhanced greenhouse effect

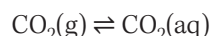
There are a range of consequences of the enhanced greenhouse effect.

- ▶ Glaciers in the Arctic and other areas have experienced significant shrinkage.
- ▶ Ice formation in the far north and south of the Earth occurs later in winter and starts to break up in spring earlier than ever before. This affects feeding behaviour of animals and the flowering and breeding of plants.
- ▶ The area of Arctic sea ice has been consistently reducing. Since 1980, NASA satellites have shown the area of sea ice has fallen from around 7 million square kilometres to just over 4 million square kilometres.
- ▶ Sea levels have been consistently rising, which in the long term will result in land loss and flooding of coastal cities. NASA satellite readings show an average rise of 85 mm since 1993, while ground readings show a rise of nearly 200 mm since 1870.

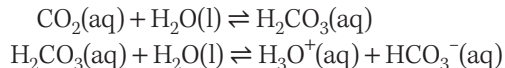
Other effects are harder to link definitively to an increase in carbon dioxide and global temperatures. However, there is no doubt that prolonged heat waves and droughts in summer and more severe snowstorms in winter are occurring. Also hurricanes, severe storms and cyclones have increased in frequency and intensity.

Measurements have shown that there has been a decrease in pH in the world's oceans since the industrial revolution, with effects as seen in Figure 10.14. This can be attributed to an increase in carbon dioxide in the atmosphere.

If there is an increase in carbon dioxide gas, then the forward reaction in the **dissolution** of carbon dioxide will be favoured, producing more aqueous carbon dioxide:



Increased aqueous carbon dioxide affects the equilibrium involving carbon dioxide and water:



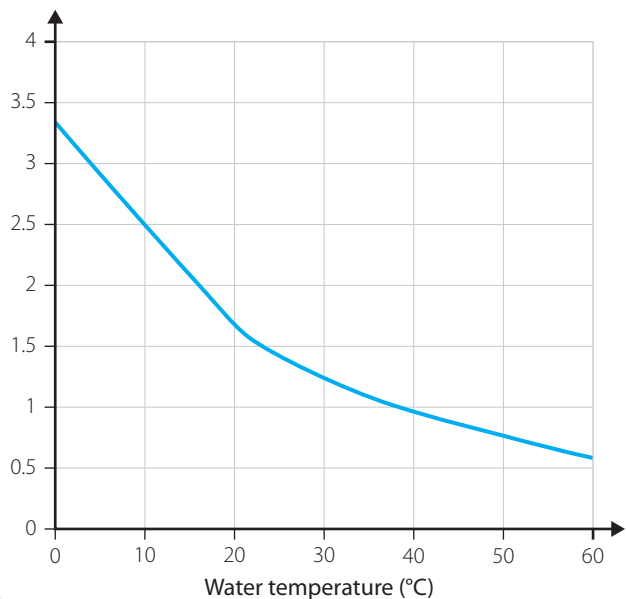
Hence, with an increase in carbon dioxide, the equilibrium involving carbon dioxide and water shifts to the right, as predicted by Le Chatelier's principle, opposing the increased aqueous carbon dioxide levels. This also drives the last equilibrium to the right, increasing levels of  $\text{H}_3\text{O}^+(\text{aq})$  and decreasing pH.

One of the largest impacts of decreasing pH and increased water temperatures is on coral reefs (Figure 10.16). Significant studies have been done on the Great Barrier Reef, showing increasing acidity and obvious damage to coral from the changes in conditions over the past 10 to 15 years.



**FIGURE 10.16** Coral damage seen by comparing healthy coral (left) and damaged coral (right)





**FIGURE 10.17** The effect of temperature on the solubility of carbon dioxide

The solubility of carbon dioxide gas depends not only on concentration but also on temperature, as seen in Figure 10.17.

As the temperature increases, more carbon dioxide molecules have enough energy to overcome the forces of attraction with the water molecules and escape as a gas, leaving less aqueous carbon dioxide.

There are several impacts of this effect on carbon dioxide concentrations. The first involves the distribution of aqueous carbon dioxide on a global scale. Water bodies in colder climates will have a greater concentration of aqueous carbon dioxide than in warmer climates. Similarly, there will be more carbon dioxide dissolved during winter than in summer.

### Dealing with the problem

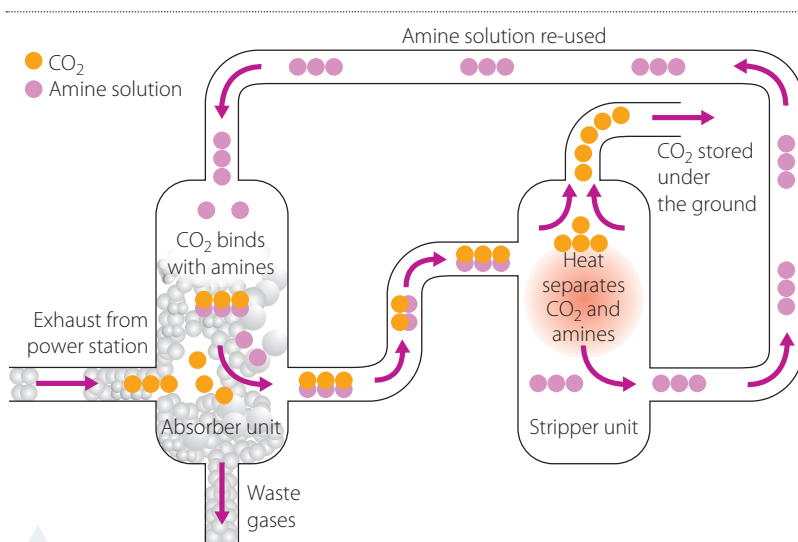
There are a number of ways of dealing with the emission of carbon dioxide during combustion. Coal-fired power stations currently produce 40 per cent of

Australia's greenhouse gas emissions. One way of reducing the amount of carbon dioxide emitted is post-combustion capture. This method is already widely in use in the oil, gas and chemical industries.

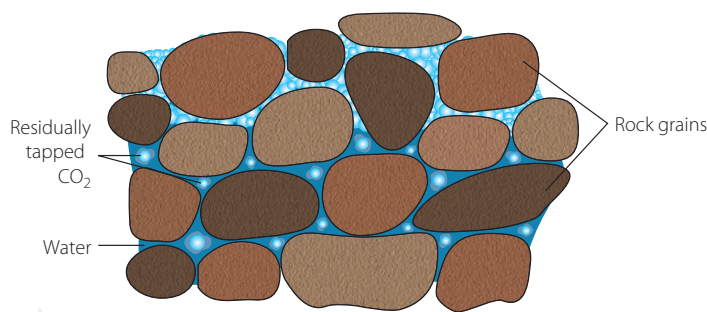
The CSIRO in Australia is a world leader in the development of this technology. They have collaborated with scientists and energy companies in Australia and China to construct post-combustion capture plants in both countries to investigate its effectiveness and continue to improve the methods used.

Normally in a coal-fired power station, the gases are vented to the atmosphere with around 10–15 per cent carbon dioxide present. These gases can instead be passed into a carbon dioxide absorber before release so that there is a reduction in up to 85% of the carbon dioxide in the gases eventually released.

The absorber is a liquid, such as an amine, that captures the carbon dioxide. Once the carbon dioxide is removed from the gases, the absorber is cleaned by removal of the carbon dioxide so the amine liquid can be re-used. The carbon dioxide is then converted to a liquid through cooling and compression (Figure 10.18) and is geologically stored (Figure 10.19). The process of storage of carbon dioxide in this manner is known as carbon sequestration and is used to attempt to slow the effects of the enhanced greenhouse effect.



**FIGURE 10.18** Process of post-combustion carbon capture



**FIGURE 10.19** Carbon dioxide liquid stored in rock

## Polymer pollution

Many organic compounds, including alkenes, alcohols, carboxylic acids and amines are used to create polymers. The chemistry of this process will be discussed in detail in chapter 13. The basic process involves small organic molecules reacting to form large structures of repeating units of the same small molecules over and over.

Polymers in common use include plastics, resins, coatings like teflon, and fibres like nylon and rayon. Along with the convenience these products bring comes a problem with polymer pollution.

By the 21st century, the volume of plastics on the world market exceeded the total volume of metals. Plastic production worldwide now exceeds 300 million tonnes a year. The amount of plastic manufactured in the first 10 years of this century equalled the total amount produced for the entire last century. Only about 10 per cent of that is recycled. Australia is one of the highest waste producers per person in the world, currently ranked in the top five waste-producing nations.

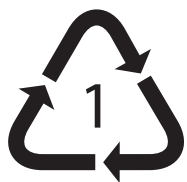
Australia contributes almost 1.3 million tonnes to plastic production, equating to 71 kg for every person. Packaging is the largest market for plastics with approximately 37 000 tonnes used per year, accounting for over a third of the consumption of raw plastic materials. Australians use over 15 000 tonnes of soft drink bottles, 30 000 tonnes of milk bottles and nearly 7 billion plastic bags per year.

While plastic packaging provides excellent protection for products and is lightweight compared to metal or cardboard, it is proving to be a major environmental problem. In the past, more than one-third of the plastic consumed in Australia was destined for landfill but today many local councils have recycling facilities for plastic materials.

Six specific types of materials account for 66 per cent of all plastics used, but not all of these can be recycled. Since most plastics are incompatible when mixed together, the different types of plastics need to be separated before they can be recycled. To help identify plastics, manufacturers use a plastics identification code, which is normally stamped on all products.

It is represented by a triangle with a number inside it. People often get this code confused with the recycling symbol, which is a triangle made up of three arrows with no number inside. The difference can be seen in Figure 10.20.

### Plastic identification code symbols



Polyethylene terephthalate (PET)

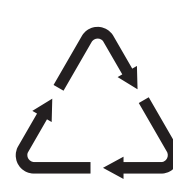
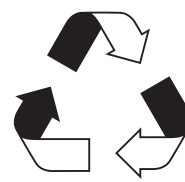


High-density polyethylene (HDPE)



Low-density polyethylene (LDPE)

### Recycling symbols



**FIGURE 10.20** Recycling symbols and plastic identification codes

The plastics identification code does not mean the plastic container can be recycled – it identifies the type of plastic the product is made from (Figure 10.21).

Although all plastic packaging is recyclable, not all is recycled through kerbside recycling schemes. Most councils are able to recycle only the plastic code groups 1, 2 and 3.

If you are unsure what plastic bottles or containers can go into your recycling service, then contact your local council or visit the Recycling Near You website.



Recycling Near You



Consequences of using hydrocarbons



**FIGURE 10.21** A recycling station

Recycling is beneficial for the environment in a number of ways. Apart from reducing the amount of landfill, recycling plastic to make new products is more energy efficient and uses only 30 per cent of the energy required to make the original product. Recycling 1 tonne of plastics can save enough energy to run a refrigerator for a month. It takes 125 recycled plastic milk bottles to manufacture a 140-litre wheelie bin.

As well as saving energy, recycling reduces the amount of raw material needed to produce plastics.

Currently, Australians recycle approximately 23 per cent of plastic packaging products. The majority of the remainder goes into landfill. This is creating a major waste management problem. Plastic debris has accumulated in natural habitats from the poles to the equator with substantial quantities in marine environments.

There is also evidence that plastics are fragmenting in the environment and as a consequence more organisms will begin to ingest these smaller fragments. There is speculation that this will lead to the transfer of toxic chemicals to wildlife.

- Hydrocarbons are primarily sourced from crude oil or natural gas that is mined, and undergoes fractional distillation to split into its components.
- Mining and transport of crude oil and natural gas can have significant environmental, economic and sociocultural impacts when accidents occur.
- Carbon dioxide produced by hydrocarbon combustion is a significant contributor to the enhanced greenhouse effect.
- The enhanced greenhouse effect has significant effects on climate, sea levels, sea ice formation and severe weather events.
- Carbon dioxide produced by hydrocarbon combustion is a significant contributor to ocean acidity levels, producing major environmental impacts.
- Polymers are made from hydrocarbons and their use causes environmental impacts through pollution and waste.



Check your understanding

- 1 Describe three ways in which hydrocarbons or their products are used daily.
- 2 Fractional distillation is used to obtain different hydrocarbons from crude oil.
  - a Identify the property that is used in this process, and explain how it is used.
  - b Predict and explain whether the petrol fraction (average 8 carbons) or kerosene (average 15 carbons) would condense higher in the fractionating tower.
- 3 Compare the processes of thermal cracking and catalytic cracking to break down larger hydrocarbon components.
- 4 Outline environmental, economic and social problems involved with the mining and transport of crude oil and natural gas, using specific examples in your answer.
- 5 Explain what a greenhouse gas is. Give an example.
- 6 Describe the link between emission of carbon dioxide and global temperatures.
- 7 Describe three possible consequences of an increase in carbon dioxide emissions.
- 8 Outline one method of reducing carbon dioxide emissions.
- 9 Outline:
  - a why there is such a problem with polymer waste in our society
  - b how recycling is being used to address this problem.

**CHECK YOUR  
UNDERSTANDING**

10.4



# 10 CHAPTER SUMMARY

## IMPORTANT NEW TERMS

After studying this chapter you should know the meaning of the following terms:

addition reaction (p. 296)

catalyst (p. 296)

catalytic cracking (p. 304)

crude oil (p. 304)

dissolution (p. 307)

enhanced greenhouse effect (p. 306)

flashpoint (p. 293)

fractional distillation (p. 304)

halogenation (p. 297)

hydrogenation (p. 296)

hydrogen halide (p. 297)

incomplete combustion (p. 300)

infrared radiation (p. 306)

inhibitor (p. 296)

Markovnikov's rule (p. 297)

natural gas (p. 305)

polymerisation (p. 290)

polyunsaturated (p. 296)

SDS (Safety Data Sheet) (p. 290)

substitution (p. 299)

thermal cracking (p. 305)

volatile (p. 292)

zeolite (p. 304)

## AFTER STUDYING THIS CHAPTER YOU SHOULD KNOW:

- the definitions for all terms in the important new terms list
- the general equations for the combustion, hydrogenation, halogenation and hydration of alkenes and alkynes
- the general equations for the combustion and substitution of halogens in alkanes
- the key principles in the safe use of organic compounds
- correct methods for the disposal of organic compounds
- how to distinguish alkanes and alkenes through a chemical test
- the environmental, economic and sociocultural implications of mining and transporting hydrocarbons
- the environmental, economic and sociocultural implications of using hydrocarbons
- how the use of hydrocarbons contributes to the enhanced greenhouse effect, ocean acidity and polymer pollution.

## YOU SHOULD BE ABLE TO:

- predict products and write equations for the combustion, hydrogenation, halogenation and hydration of simple alkenes and alkynes
- predict products and write equations for the combustion and substitution of halogens of simple alkanes
- identify the risks of working with organic chemicals
- take suitable precautions in the laboratory when working with organic chemicals
- safely dispose of organic chemicals during your practical investigations
- outline hazards involved with industrial use of organic chemicals
- outline environmental, economic and sociocultural implications of mining, transport and use of hydrocarbons.

# 10 CHAPTER REVIEW QUESTIONS



Review quiz

- 1 Identify the key features contained within a SDS.
- 2 Explain the need for a document like a SDS to exist.
- 3 With reference to organic chemicals, explain the difference between the terms 'volatile' and 'flashpoint'.
- 4 From question 3, explain how knowledge of those properties allow for identification of risks when using organic chemicals.
- 5 Explain the difference between inhalation, ingestion and absorption of chemicals.
- 6 Compare acute poisoning and chronic poisoning with reference to organic chemicals. You should include exposure methods and general symptoms in your answer.
- 7 Identify key precautions you can take in your school investigations to minimise risks associated with using organic chemicals. Link each precaution to a specific risk you are trying to minimise.
- 8 What is the name given to the type of reaction where the following occurs?
  - a The addition of water to alkenes/alkynes
  - b The addition of oxygen to hydrocarbons to produce energy
  - c The addition of halogens to alkenes/alkynes
  - d The replacement of a hydrogen atom with a halogen atom in an alkane
- 9 Write equations for:
  - a the hydration of 1-pentene
  - b the hydration of propyne.
- 10 Write equations for:
  - a the reaction of ethene with bromine
  - b the reaction of ethane with chlorine under UV light
  - c the two step reaction of 1-butyne with chlorine
  - d the reaction of propene with hydrogen chloride.
- 11 Write equations for:
  - a the complete combustion of 2-heptene
  - b the complete combustion of propyne
  - c the combustion of 2-methylbutane.
- 12 Write two equations to show different possible products in the incomplete combustion of butane.
- 13 Describe possible health issues with the production of carbon monoxide and soot in incomplete combustion.
- 14 Describe the catalysts required for:
  - a hydrogenation of an alkene
  - b production of margarine
  - c conversion of an alkyne to an alkene
  - d hydration of an alkene
  - e hydration of an alkyne.
- 15 Describe how crude oil is separated into its fractions.
- 16 Outline potential environmental issues with the mining and transport of crude oil and natural gas.
- 17 Explain, using equations, how the ocean has become more acidic. Describe the consequences of this.
- 18 The enhanced greenhouse effect can be linked to increased emission of carbon dioxide from fuel combustion.
  - a Explain why carbon dioxide is a greenhouse gas.
  - b Describe the link between fuel combustion and the enhanced greenhouse effect, using an equation in your answer.
  - c Outline the evidence for increasing levels of carbon dioxide in the atmosphere.
- 19 Describe some possible consequences of the enhanced greenhouse effect.
- 20 Polymer pollution has significant environmental and economic implications.
  - a Suggest reasons that there has been an increase in polymer pollution in recent times.
  - b Outline steps that have been taken to address this form of pollution and the economic benefit of doing so.
- 21 When water is added to 1-butene, two possible products are formed.
  - a Draw and name each possible product.
  - b Explain which product is more likely to be formed and why.
- 22 In addition reactions, there are times when only one product can form, and times when multiple products can form.
  - a Using specific examples, explain how only one product can form.
  - b Using specific examples, explain how multiple products can form.
- 23 Methane undergoes substitution reactions with chlorine under specific conditions.
  - a Identify what specific conditions are required for this reaction to occur.
  - b Explain how this knowledge can be used to distinguish alkanes and alkenes.
  - c Write a series of equations to show the conversion of methane to tetrachloromethane.

- 24** You are given samples of heptane and 2-heptene.
- Outline a method you could use to distinguish between the two samples. Include all chemicals used and what results you would expect.
  - Identify one significant risk with the method you outlined, and how you would minimise its effects.
  - Write equations for any reactions that occurred.

- 25** Four bottles containing clear liquids were found on the laboratory shelf with no labels. The bottles are known to contain 1-hexene, pentane, water and ethanol. A series of tests were conducted on each sample and the results are shown below.
- Using the information from the table, identify which bottle contained which chemical. Explain your answer.
  - Write equations for any reactions that occurred.

BOTTLE	SOLUBLE IN WATER	FLAMMABLE (UNDERGOES COMBUSTION)	DECOLOURISES BROMINE IN THE ABSENCE OF UV LIGHT
A	Yes	No	No
B	No	Yes	Yes
C	No	Yes	No
D	Yes	Yes	No

# 11 Alcohols

## INQUIRY QUESTION

How can alcohols be produced and what are their properties?

### Students:

conduct a practical investigation to measure and reliably compare the enthalpy of combustion for a range of alcohols **ICT N**

write equations, state conditions and predict products to represent the reaction of alcohols, including but not limited to: **ACSCH12, ASCSH36**)

- combustion
- dehydration
- substitution with HX
- oxidation

investigate the production of alcohols, including:

- substitution reactions of halogenated organic compounds
- fermentation

investigate the products of the oxidation of primary and secondary alcohols

compare and contrast fuels from inorganic sources to biofuels, including ethanol. **ICT**

Chemistry Stage 6 Syllabus © NSW Educational Standard Authority for and on behalf of the Crown in right of the State of New South Wales, 2017





Prior knowledge

Alcohols are widely used in society and in industry. Ethanol, or ethyl alcohol, is used in alcoholic beverages, as a disinfectant, and as a solvent. In industry, various alcohols are used as feedstocks to make a wide range of products including plastics, cosmetics, medicines and detergents.

An increasingly important use of ethanol is as a fuel additive. Petrol stations provide an E10 fuel, which is fuel with 10 per cent ethanol. Ethanol burns cleaner than the hydrocarbons in fuel, comes from a renewable source through fermentation of crops, and is cheaper than non-ethanol fuel.

Alcohols undergo a number of important reactions including combustion, dehydration (removal of water), oxidation and reaction with halogen halides. Preparation of alcohols can occur through either two different chemical processes, fermentation or alkene hydration. Alcohols also react with metals, including sodium. This reaction will be discussed in chapter 15.

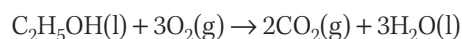


**FIGURE 11.1** E10 fuel containing up to 10 per cent ethanol is becoming increasingly popular with motorists.

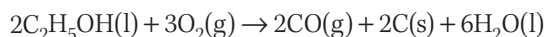
## 11.1 Combustion of alcohols

Alcohols undergo combustion in the exact manner of hydrocarbons like alkanes. Complete combustion produces carbon dioxide, water and energy. Incomplete combustion can also produce carbon monoxide and carbon (soot), with a reduction in energy produced per mole of fuel combusted.

Complete combustion of ethanol releases approximately 1370 kJ per mole of ethanol combusted, as per the reaction:



Incomplete combustion releases far less energy than this as well as the waste products of carbon monoxide and soot, the harmful effects of which were discussed in chapter 10, as per the reaction:



### Enthalpy of combustion of alcohols

Enthalpy was discussed in chapters 14 and 15 of *Chemistry in Focus Year 11* as well as in chapter 5 of this text. A brief summary of the key points are below. For more detailed revision, refer to your Year 11 textbook, especially section 14.5 on the heat of combustion, and chapter 5.

- Chemical reactions can be endothermic (absorb heat) or exothermic (release heat). All combustion reactions are exothermic, which means they release energy to the surrounding environment, which is often captured and put to practical use.
- The specific heat capacity ( $c$ ) of a substance is the amount of heat required to increase the temperature of unit mass of the substance by exactly  $1^\circ\text{C}$  (or through 1 kelvin). Specific heat capacity is measured in joules per kelvin per gram ( $\text{JK}^{-1}\text{g}^{-1}$ ) or in joules per kelvin per kilogram ( $\text{JK}^{-1}\text{kg}^{-1}$ ). The specific heat capacity of water is essential for enthalpy of combustion calculations and this is  $4.18\text{JK}^{-1}\text{g}^{-1}$  or  $4180\text{JK}^{-1}\text{kg}^{-1}$ . The measurement and calculation of heat changes is called **calorimetry**.

- ▶ The quantity of heat that flows from one object or substance to another,  $q$ , is found by:  $q = mc\Delta T$ , where  $m$  is the mass of substance being heated,  $c$  is the specific heat capacity of the substance and  $\Delta T$  is the change in temperature of the substance.
- ▶ By calculating the number of moles of substance involved in the reaction, the heat released or absorbed per mole can be calculated. This makes it easier to compare reactions and/or chemicals.
- ▶ Enthalpy is a measure of the total energy possessed by a substance or group of substances (for example, the products or reactants in a chemical reaction).

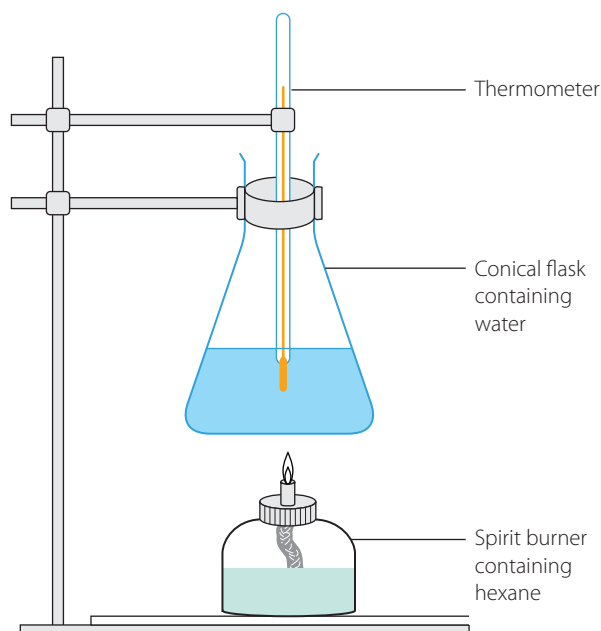
The change in enthalpy for a chemical reaction ( $\Delta H$ ) is defined as the heat absorbed or released per mole of specified reactant or product when the reaction occurs at constant pressure. **Enthalpy of combustion** is the heat energy that is released when 1.00 mole of fuel is combusted in excess oxygen at standard atmospheric pressure.

Key points to note about enthalpy of combustion reactions:

- ▶ The combustion reaction occurs under complete combustion conditions (excess oxygen) so the products are carbon dioxide and water.
- ▶ The water produced is in liquid form for enthalpy of combustion. The energy required to convert the water from liquid to gas changes the enthalpy value. All given enthalpy values assume liquid water in the balanced equation.
- ▶ The value for  $\Delta H$  is always negative since all combustion reactions are exothermic and release heat.

It is difficult to directly measure the heat released when a fuel undergoes combustion, so an indirect method is used by applying the law of conservation of energy. A known quantity of water is heated by the fuel and the temperature changes in the water are used to calculate the amount of heat given to the water by the fuel. This is the same as the heat produced by the fuel (law of conservation of energy).

These experiments are called **calorimetric** experiments since they measure changes in temperature, and are used to calculate heat energy. Figure 11.2 shows a possible set-up for an experiment to measure the enthalpy of combustion of a fuel. Many variations of this set-up are possible, including placing a beaker on a tripod to be heated.



**FIGURE 11.2** Equipment set-up to measure the enthalpy of combustion of a fuel

### ▶ WORKED EXAMPLE (11.1)

A student measured 150 g of water into a flask and placed it above a spirit burner filled with ethanol. The temperature of the water initially was 19.1°C and the initial mass of the spirit burner and fuel was 160.25 g. The water was heated until the temperature reached 41.9°C. The spirit burner was reweighed and had a mass of 158.42 g. Calculate the enthalpy of combustion of the ethanol.



ANSWER	LOGIC
Mass fuel = 160.25 – 158.42 = 1.83 g $\Delta T = 41.9 - 19.1 = 22.8^{\circ}\text{C}$	<ul style="list-style-type: none"> <li>Use the data in the question to determine the mass of the fuel combusted and <math>\Delta T</math>.</li> </ul>
$q = mc\Delta T$ $q = 150 \times 4.18 \times 22.8$ $q = 1.430 \times 10^4 \text{ J}$ Therefore, heat released by the fuel = $1.430 \times 10^4 \text{ J} = 14.3 \text{ kJ}$	<ul style="list-style-type: none"> <li>Use <math>q = mc\Delta T</math> to determine the heat absorbed by the water in kJ. Note that the <math>m</math> in this part of the equation is the mass of water heated <i>not</i> the fuel combusted.</li> <li>Conversion of J to kJ involves dividing by 1000.</li> <li>By the law of conservation of energy, this is also the heat released by the fuel.</li> </ul>
$M(\text{C}_2\text{H}_5\text{OH}) = (2 \times 12.01) + (6 \times 1.008) + 16.00$ = 46.068 $\text{g mol}^{-1}$ $n = \frac{m}{MM} = \frac{1.83}{46.068} = 0.0397 \text{ mol}$	<ul style="list-style-type: none"> <li>Use the mass of the fuel and its molecular weight to determine the moles of fuel combusted.</li> </ul>
$\Delta H = \frac{14.3}{0.0397} = 360 \text{ kJ mol}^{-1}$	<ul style="list-style-type: none"> <li>Use the heat released and the moles of fuel combusted to calculate the enthalpy of combustion:  <math display="block">\Delta H = \frac{\text{heat released}}{\text{number moles fuel combusted}}</math> </li> <li>A negative sign is used since the reaction is exothermic and releases heat.</li> </ul>

#### TRY THESE YOURSELF

- Combustion of 1-propanol is used to heat 100 mL of water. The temperature of the water increased from 14.5°C to 45.1°C. A mass of 0.372 g of 1-propanol was combusted during this investigation. Calculate the enthalpy of combustion of 1-propanol in  $\text{kJ mol}^{-1}$ .
- The enthalpy of combustion of ethanol is  $\Delta H = -1360 \text{ kJ mol}^{-1}$ . If 0.843 g of ethanol is combusted and used to heat 175 g water, calculate the theoretical temperature rise of the water.

## INVESTIGATION 11.1



Information and communication technology capability

### Enthalpy of combustion of alcohols

#### AIM

To measure the enthalpy of combustion for various alcohols and compare to theoretical values.

#### MATERIALS

- 3–5 different alcohols of varying molecular weight (for example, methanol, ethanol, 1-propanol, 1-butanol, 1-pentanol)
- Spirit burners containing the alcohols
- 250 mL beakers
- Thermometers or data loggers with temperature probes
- Matches
- Clamps, retort stands
- Beaker gloves





WHAT ARE THE RISKS IN DOING THIS INVESTIGATION?	HOW CAN YOU MANAGE THESE RISKS TO STAY SAFE?
Alcohols are flammable liquids.	Spirit burners are used to contain the fuel and separate them from the flame.
Glassware and other equipment will become hot and may cause burns.	Use beaker gloves or similar to handle hot glassware. Allow equipment time to cool before packing away.

What other risks are associated with your investigation? How can you manage these?

#### METHOD

You are to design a method based on Figure 11.2 (page 317) and Worked example 11.1 (page 317) to measure the enthalpy of combustion for a range of alcohols with different molecular weights. In your design, you should consider:

- the measurements you need to make
- how you will control variables in this experiment (**Hint:** Will you have a constant temperature increase, or burn the fuel for a constant period of time – which seems more valid?)
- whether you will conduct trials.

**Note:** For this investigation, due to time constraints, you may wish to conduct a class investigation and share data.

#### RESULTS

- Record your results in an appropriate table.
- Use your data to calculate the enthalpy of combustion for each alcohol, showing full working.

#### DISCUSSION

- Describe how you controlled variables in this investigation and the reason for doing so.
- Construct a graph of molecular weight (horizontal axis) against enthalpy of combustion (vertical axis).
- Use your graph to describe any trend seen in this experiment.
- Research the theoretical value for the enthalpy of combustion for each of the alcohols you used in this investigation. Plot their values on the graph you constructed. Thus compare the experimental enthalpy values you measured to the theoretical values.
- Suggest reasons for any differences between the experimental and theoretical values.

#### CONCLUSION

- Write a conclusion based on the aim of this investigation.
- Comment on the accuracy, reliability and validity of this experiment, using your investigation results.

Accuracy, reliability and validity are discussed on page 10

## Analysing enthalpy of combustion experiments

Enthalpy of combustion values that are measured by using the type of experiment seen in Investigation 11.1 are of very low accuracy. The values obtained by experimentation are quite different to the theoretical values. It is not unusual to achieve results that are 80 per cent lower than expected.

Theoretical values for the enthalpy of combustion cannot be measured via experimentation, only determined by using more easily measured enthalpy values and known bond energies. These methods were discussed in the Year 11 course, and you would have performed very similar calculations.

There are many reasons for experimental values being inaccurate. These are systematic errors since the error produces results that have a significant difference from the true value.

One major assumption is that all heat from the combustion of the fuel is transferred directly to the water. Much of that heat does not go to the water, but goes to the air, glass containers holding the water, tripods, gauze mats, thermometer and any other equipment used. Hence, less heat than is produced goes into the water, resulting in a lower temperature rise and a lower enthalpy value.

Incomplete combustion of the fuel occurs since it is combusted in air (approximately 20 per cent oxygen), not under excess oxygen conditions. Incomplete combustion of a fuel produces less energy per mole than when complete combustion occurs. This lowers the possible total heat that could be transferred to the water and is often seen as soot on the glassware.

There will be a loss of heat from the water in the beaker to the atmosphere. As the combustion takes time, the water will lose heat from the surface. This can be reduced using a lid or cover to contain this heat.

There is also evaporation of alcohol from the wick of spirit burner, since the alcohol used has a low boiling point, some fuel is evaporated from the wick rather than being combusted. This fuel is considered to have combusted so will affect the enthalpy calculations, increasing the moles of fuel used in the calculations.

### Comparing energy produced by fuels

Comparing the energy produced by fuels in a chemical context is done in units like  $\text{kJ mol}^{-1}$ . However, when you go to buy petrol, or other fuels, prices are given per litre for liquid fuels or per kilogram for solid fuels. For everyday comparison, use of litres or kilograms is much more relevant for people than moles.

To calculate the heat released per gram of fuel, use:

$$\frac{\Delta H (\text{kJ mol}^{-1})}{MM(\text{g mol}^{-1})} = \text{heat released (kJ g}^{-1}\text{)}$$

To calculate the heat released per litre of fuel, use:

$$\frac{\Delta H (\text{kJ mol}^{-1})}{MM(\text{g mol}^{-1})} \times \text{density fuel (g L}^{-1}\text{)} = \text{heat released (kJ L}^{-1}\text{)}$$

#### WORKED EXAMPLE 11.2

Ethanol  $\text{C}_2\text{H}_5\text{OH}$  has an enthalpy of combustion  $\Delta H = -1360 \text{ kJ mol}^{-1}$  and a density of  $0.7893 \text{ g mL}^{-1}$ . Calculate:

- the heat released per gram of ethanol
- the heat released per litre of ethanol.

ANSWER	LOGIC
<p>1 <math>MM = (2 \times 12.01) + (6 \times 1.008) + 16.00</math>  <math>= 46.068 \text{ g mol}^{-1}</math></p>	<ul style="list-style-type: none"> <li>Calculate the molecular mass of the fuel in question.</li> </ul>
<p>Heat released:</p> $= \frac{\Delta H (\text{kJ mol}^{-1})}{MM(\text{g mol}^{-1})}$ $= \frac{1360}{46.068}$ $= 29.52 \text{ kJ g}^{-1}$	<ul style="list-style-type: none"> <li>Use the formula here to calculate the energy released in <math>\text{kJ g}^{-1}</math>:  <math display="block">\frac{\Delta H (\text{kJ mol}^{-1})}{MM(\text{g mol}^{-1})} = \text{heat released (kJ g}^{-1}\text{)}</math> <p><b>Note:</b> There is no negative sign; this is heat released and specific to combustion of fuels so the sign is not necessary.</p> </li> </ul>

ANSWER	LOGIC
<p>2 Heat released:</p> $= \frac{\Delta H \text{ (kJ mol}^{-1}\text{)}}{MM \text{ (g mol}^{-1}\text{)}} \times \text{density fuel (g L}^{-1}\text{)}$ $= \frac{1360}{46.068} \times (07893 \times 1000)$ $= 2.33 \times 10^4 \text{ kJ L}^{-1}$	<ul style="list-style-type: none"> <li>Use the formula here to calculate the energy released in <math>\text{kJ L}^{-1}</math>:           <math display="block">\frac{\Delta H \text{ (kJ mol}^{-1}\text{)}}{MM \text{ (g mol}^{-1}\text{)}} \times \text{density fuel (g L}^{-1}\text{)} = \text{heat released (kJ L}^{-1}\text{)}</math> <p><b>Note:</b> Convert the density of fuel to <math>\text{g L}^{-1}</math> if not provided with those units. In this case, convert from <math>\text{g mL}^{-1}</math> to <math>\text{g L}^{-1}</math> by multiplying by 1000.</p> </li> <li>Again, the negative sign is not necessary.</li> </ul>

#### TRY THIS YOURSELF

Butanol ( $\text{C}_4\text{H}_9\text{OH}$ ) has an enthalpy of combustion  $\Delta H = -2670 \text{ kJ mol}^{-1}$  and a density of  $0.81 \text{ g mL}^{-1}$ .

Calculate:

- the heat released per gram of butanol
- the heat released per litre of butanol.

There is a significant difference between heat released per mole, per gram and per litre, seen in Table 11.1. For example, the enthalpy of combustion (in  $\text{kJ mol}^{-1}$ ) of 1-pentanol is 4.5 times as great as methanol, but only 1.7 times greater when comparing per gram. Thus, it is important to compare the heat released by fuels in the form in which they are usually purchased.

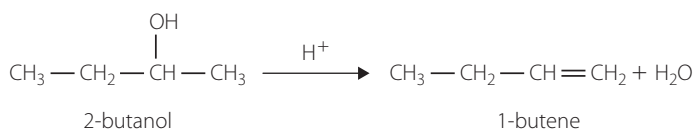
**TABLE 11.1** Heat released per mole, per gram and per litre for various fuels

FUEL	ENTHALPY COMBUSTION ( $\text{kJ mol}^{-1}$ )	HEAT RELEASED PER GRAM ( $\text{kJ g}^{-1}$ )	HEAT RELEASED PER LITRE ( $\text{kJ L}^{-1}$ )
Methanol	-726	22.7	17978
Ethanol	-1360	29.7	23433
1-propanol	-2021	33.6	26980
1-butanol	-2676	36.1	29241
1-pentanol	-3329	37.7	30687

- Alcohols undergo complete and incomplete combustion, producing carbon dioxide and water (complete) or carbon monoxide and/or soot (incomplete).
- Incomplete combustion results in lower amounts of energy being produced per mole of fuel combusted.
- The enthalpy of combustion is the heat energy released when 1.00 mole of fuel is combusted in excess oxygen at standard atmospheric pressure, and is always negative.
- Calorimetric experiments are used to measure the enthalpy of combustion of fuels like alcohols. These experiments are always very inaccurate due to a number of systematic errors.
- Fuels can be compared by the energy released per mole, per gram or per litre.

- 1 Define 'enthalpy of combustion'.
- 2 Write equations for the complete combustion of:
  - a 1-pentanol
  - b 2-methyl-2-propanol.
- 3 Describe, using equations for the combustion of ethanol, the differences between incomplete and complete combustion.
- 4 Outline an experiment that can be used to measure the enthalpy of combustion of an alcohol. Include the measurements you need to take and any calculations you need to perform.
- 5 120 g of water was heated by 1.26 g of 1-hexanol. The temperature rise was 11.3°C. Calculate the enthalpy of combustion of 1-hexanol.
- 6 A student conducted an investigation to determine the enthalpy of combustion of 1-butanol. 150 g of water was heated from 16.3°C to 39.6°C using 0.48 g of 1-butanol.
  - a Calculate the enthalpy of combustion in  $\text{kJ mol}^{-1}$  of 1-butanol.
  - b The energy released when 1-butanol combusts is  $36.1 \text{ kJ g}^{-1}$ . Calculate the energy released from the experimental data, and hence, comment on the accuracy of this investigation.
- 7 Butane ( $\text{C}_4\text{H}_{10}$ ) has an enthalpy of combustion of  $2874 \text{ kJ mol}^{-1}$ . 1.00 g of butane was combusted, heating 750 mL of water with an initial temperature of 18.5°C.
  - a Calculate the theoretical maximum temperature of the water.
  - b Give two reasons this theoretical maximum would not be reached in an investigation.
- 8 Any investigation to measure the enthalpy of combustion is very inaccurate. Suggest ways to modify the investigation you have performed to measure the enthalpy of combustion, explaining how your modification would make the experiment more accurate.

## 11.2 Dehydration of alcohols



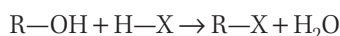
Alcohols undergo dehydration reactions by losing water to form alkenes when heated with concentrated sulfuric or phosphoric acids. Note that not all acids will cause dehydration of an alcohol. The reaction to the left shows 2-butanol reacting to form 1-butene and water.

It is also possible in this example for 2-butene to form as the product instead of 1-butene. The product that forms is not determined by chance but the reasons one product will be favoured are beyond the scope of this course.

An alternative method of dehydrating alcohols involves passing gaseous ethanol over heated aluminium oxide powder. The aluminium oxide acts as a catalyst, causing the cracking of ethanol into ethene and water vapour.

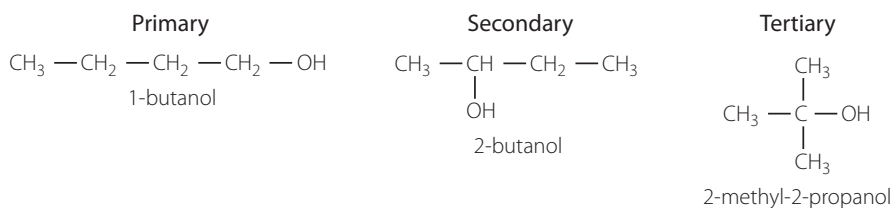
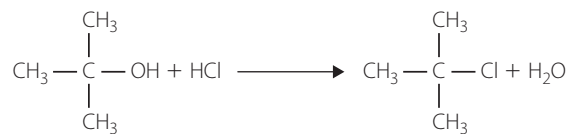
## 11.3 Substitution with hydrogen halides (HX)

When alcohols react with a hydrogen halide (HX), like hydrogen chloride or hydrogen bromide, a substitution reaction occurs. The products are an **alkyl halide** and water. The general reaction is:



The equation on the right shows the addition of hydrogen chloride to 2-methyl-2-propanol, producing an alkyl halide (2-chloro-2-methylpropane) and water.

As discussed in chapter 10, alcohols are classed as primary, secondary or tertiary based on the number of carbon atoms attached to the carbon bearing the —OH group, as seen in Figure 11.3.



**FIGURE 11.3** Primary, secondary and tertiary alcohols

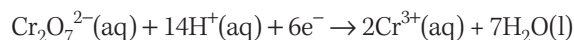
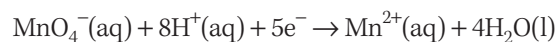
In reactions with hydrogen halides, tertiary alcohols are most reactive and will have very fast reactions with HX. Secondary alcohols are less reactive, with primary alcohols even less reactive. Methanol in particular is very difficult to react with HX.

The hydrogen halide reactivity in this reaction increases as you go down the halogen group. HF is very difficult to react, while HI is the most reactive of the HX compounds.

## 11.4 Oxidation of alcohols

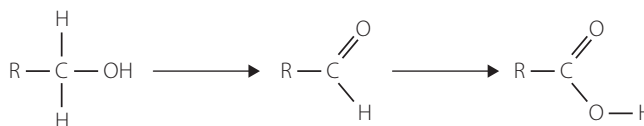
Alcohols readily undergo oxidation with strong oxidising agents such as acidified permanganate ion ( $\text{MnO}_4^-$ ) or dichromate ion ( $\text{Cr}_2\text{O}_7^{2-}$ ) solutions.

Permanganate and dichromate ion solutions are reduced readily (acting as strong oxidising agents) according to the following redox half reactions:



### Oxidation of primary alcohols

Primary alcohols are oxidised to form aldehydes, which are in turn oxidised to form carboxylic acids. The general reaction is shown on the right.

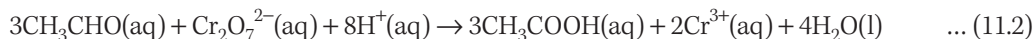


The following example shows the oxidation of ethanol to the aldehyde ethanal, then the further oxidation of ethanal to ethanoic acid using potassium dichromate as the oxidising agent.

Ethanol → ethanal:



Ethanal → ethanoic acid:

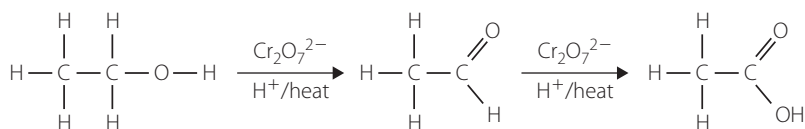




The overall equation for the oxidation of a primary alcohol to a carboxylic acid is obtained by adding equations 11.1 and 11.2:



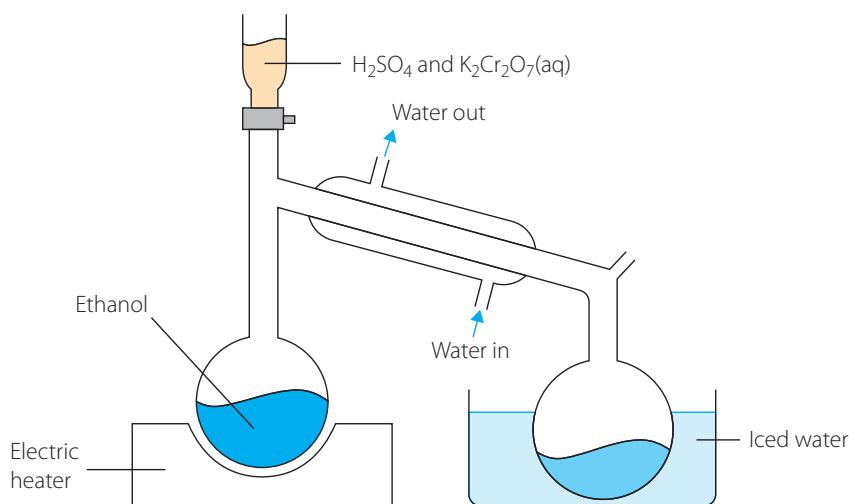
Since these are organic reactions, they can also be written with only the structural formula of the organic molecules. Other conditions and reactants are shown over the arrows as below. You should be familiar with writing both structural and full balanced equations.



Aldehydes are easily oxidised to form carboxylic acids, so the final product will not contain any aldehyde, only carboxylic acid. To obtain an aldehyde through oxidation of a primary alcohol, it needs to be distilled off

as it forms. Figure 11.4 shows the equipment required for this process. The ethanol is heated in the flask by a heating mantle or similar until it is just above the boiling point of the ethanal. As ethanal has a lower boiling point than ethanol, ethanol will not boil off and contaminate the aldehyde.

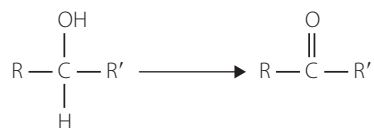
The acidified dichromate ion solution is added drop by drop to the heated ethanol, which immediately oxidises to ethanal. Since the mixture is above the boiling point of the ethanal, it immediately boils and passes through the condenser to be collected in the second flask. Since the aldehyde is immediately removed from the dichromate ions, it will not undergo further oxidation to the carboxylic acid.



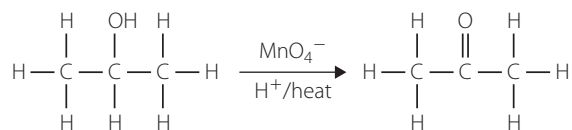
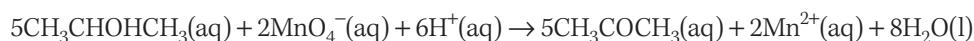
**FIGURE 11.4** Collection of aldehyde through distillation

## Oxidation of secondary alcohols

Secondary alcohols are oxidised to form ketones, which cannot be further oxidised. So the final product in the oxidation of a secondary alcohol is a ketone. Acidified permanganate and dichromate ions both oxidise secondary alcohols. The general reaction is shown here:



The oxidation of 2-propanol to propanone is shown below in both forms:



## Oxidation of tertiary alcohols

Tertiary alcohols cannot be oxidised without drastic conditions. In primary and secondary alcohols, oxidation involves the removal of a hydrogen atom from the carbon attached to the hydroxyl group. This involves breaking a C—H bond.

Oxidising a tertiary alcohol involves the breaking of a C—C bond, which requires more energy than a C—H bond.

## Distinguishing types of alcohols

When dichromate ions are used to oxidise alcohols, a distinctive colour change is seen. Dichromate ions ( $\text{Cr}_2\text{O}_7^{2-}$ ) are orange, while their reduced form, chromium(III) ions ( $\text{Cr}^{3+}$ ), are green. Thus a colour change is seen when primary and secondary alcohols oxidise, but since tertiary alcohols do not oxidise, no colour change is seen. It is important to note that the colour change is not from the alcohols, which are all colourless, but from the oxidising agent, the dichromate ions.

Under acidic conditions, permanganate ions change colour from purple to colourless when reducing to  $\text{Mn}^{2+}$ . In classroom laboratory conditions, sometimes a brown colour is seen upon formation of  $\text{MnO}_2$ , which makes this test less reliable than the dichromate ion test.

# INVESTIGATION 11.2

## Oxidation of alcohols

### AIM

To examine and compare the reactions of primary, secondary and tertiary alcohols.

### MATERIALS

- 10 mL of ethanol, 1-butanol, 2-butanol, 2-methyl-2-propanol. (If these are not available, ensure you have at least one primary, one secondary and one tertiary alcohol.)
- 5 mL of  $0.1 \text{ mol L}^{-1}$  sodium dichromate solution ( $\text{Na}_2\text{Cr}_2\text{O}_7$ )
- 5 mL of  $0.01 \text{ mol L}^{-1}$  potassium permanganate solution ( $\text{KMnO}_4$ )
- 5 mL  $6 \text{ mol L}^{-1}$  sulfuric acid ( $\text{H}_2\text{SO}_4$ )
- Water bath (hot water from a kettle in a beaker)
- 250 mL beaker
- 5 large test tubes
- Test-tube rack
- 10 mL measuring cylinder
- Thermometer
- Labels
- Disposable droppers
- Waste bottle
- Gloves
- Safety glasses





WHAT ARE THE RISKS IN DOING THIS INVESTIGATION?	HOW CAN YOU MANAGE THESE RISKS TO STAY SAFE?
Sodium dichromate is toxic.	Avoid contact with skin by using appropriate personal protection equipment. Avoid inhalation of vapours by using chemicals in a fume cupboard.
Concentrated sulfuric acid is corrosive and emits harmful vapours.	Teacher may dispense acid as required. Avoid contact with skin by using appropriate personal protection equipment. Avoid inhalation of vapours by using chemicals in a fume cupboard.
Alcohols are flammable.	Avoid using alcohols around flame source or hot equipment.

What other risks are associated with your investigation? How can you manage these?

#### METHOD

- 1 Prepare a water bath using boiling water from a kettle in a 250 mL beaker. Replace as necessary as water cools.

#### PART A: REACTION WITH PERMANGANATE IONS ( $\text{MnO}_4^-$ )

- 1 Measure 2 mL of each alcohol into a separate, labelled test tube.
- 2 In a separate test tube, mix 4 mL potassium permanganate with 1 mL sulfuric acid. Note the colour of the solution.
- 3 Add 4–5 drops of the acidified permanganate ion solution into each of the test tubes containing the alcohols.
- 4 Place the test tubes into the water bath for 1–2 minutes or until a change is seen.
- 5 Record any observations made, including colour changes.
- 6 Dispose of the contents of the test tubes in a waste container. Do not dispose of any materials down the sink.

#### PART B: REACTION WITH DICHROMATE IONS ( $\text{Cr}_2\text{O}_7^{2-}$ )

- 1 Measure 2 mL of each alcohol into a separate, labelled test tube.
- 2 In a separate test tube, mix 4 mL sodium dichromate with 2 mL sulfuric acid. Note the colour of the solution.
- 3 Add 1 mL of the acidified dichromate ion solution into each of the test tubes containing the alcohols. Shake gently to mix.
- 4 Place the test tubes into the water bath for 5 minutes or until a change is seen.
- 5 Record any observations made, including colour changes.
- 6 Dispose of the contents of the test tubes in a waste container. Do not dispose of any materials down the sink.

#### RESULTS

Record your observations in a suitably formatted table.

#### DISCUSSION

- 1 Using a balanced redox half equation, explain any colour changes seen for:
  - a oxidation using permanganate ion solution
  - b oxidation using dichromate ion solution.
- 2 Write equations for any reactions that occurred in your investigation.
- 3 Explain whether you can positively identify any type (primary, secondary or tertiary) of alcohol using this method.
- 4 A suggestion is made to distinguish between primary and secondary alcohols by adding carbonate ions to the product.
  - a Explain, using an equation, how this could show the difference between the reaction of a primary or secondary alcohol.
  - b Explain possible problems using this method and why it might not allow you to tell the difference between the two alcohols.

#### CONCLUSION

Assess the usefulness of dichromate ions and permanganate ions for distinguishing between primary, secondary and tertiary alcohols.

- Alcohols undergo dehydration reactions to form alkenes when heated with concentrated acids, or passed over powdered aluminium oxide catalyst.
- When hydrogen halides (HX) are added to alcohols, a substitution reaction occurs, forming an alkyl halide and water.
- Tertiary alcohols are most reactive when added to HX, then secondary, then primary alcohols. Methanol is very difficult to react with HX.
- Primary alcohols undergo oxidation when added to acidified dichromate or permanganate ions, forming an aldehyde, then oxidising further to a carboxylic acid.
- To collect an aldehyde from a primary alcohol, it must be distilled and collected as it forms.
- Secondary alcohols undergo oxidation to form a ketone.
- Tertiary alcohols do not undergo oxidation.

#### CHECK YOUR UNDERSTANDING

11.2

11.3

11.4

- Identify the conditions required for the dehydration of alcohols.
- Write equations for, and name the organic products formed in, the dehydration of:
  - ethanol
  - 2-butanol
  - 2-methyl-3-pentanol.
- Write equations for, and name the organic products formed when:
  - HCl is added to 2-propanol
  - HBr is added to 1-butanol
  - HI is added to 2-methyl-2-propanol.
- Which of the alcohols in question 3 would you expect to most readily react with HCl? Justify your answer.
- Write redox half equations to show the reduction of permanganate ions and dichromate ions. Identify any colour changes that occur in these reactions.
- Write equations for, and name the organic products formed, when the following alcohols are oxidised.
  - 2-butanol
  - Methanol
  - 2-methyl-2-hexanol
- Write balanced equations for the oxidation of:
  - 1-propanol by acidified permanganate solution
  - 2-pentanol by acidified dichromate solution.
- Outline an investigation you could do that would distinguish between ethanol and 2-methyl-2-propanol. Include a detailed method with volumes and concentrations of required chemicals. Explain what visual observation you would make to tell the two alcohols apart.

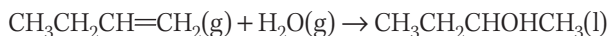
## 11.5 Production of alcohols

Alcohols are prepared in a number of different ways. For alcohol in beverages and biofuels, fermentation of carbohydrates is used. Industrial alcohol is usually produced either by hydration of alkenes or by substitution of haloalkanes. Increasingly, however, industrial alcohol is also produced at biofuel plants with further distillation to give a product that is 99.9 per cent pure.

## Production from alkenes

The addition of water to an alkene in the presence of sulfuric acid results in breaking of the double bond and a hydroxyl group being added to the molecule. This reaction was discussed in chapter 10.

For example, the production of 2-butanol from 1-butene:



## Production from halogenated organic compounds

Addition of water to a **haloalkane** results in a **substitution reaction** where the halogen atom is replaced by a hydroxyl group to form an alcohol. The reaction between 2-bromobutane and water to form 2-butanol is shown below.



Haloalkanes are more likely to undergo substitution reactions than non-halogenated alkanes. The carbon-halogen bond in a haloalkane is much easier to break than the carbon-carbon or carbon-hydrogen bonds in the molecule.

This is due to the difference in bond energies. **Bond energy** is the energy required to break a chemical bond. In order for this reaction to occur, the C-X bond needs to break to allow for the substitution of the -OH group. Table 11.2 shows the relevant bond energies for a haloalkane.

**TABLE 11.2** Bond energies for haloalkane molecules

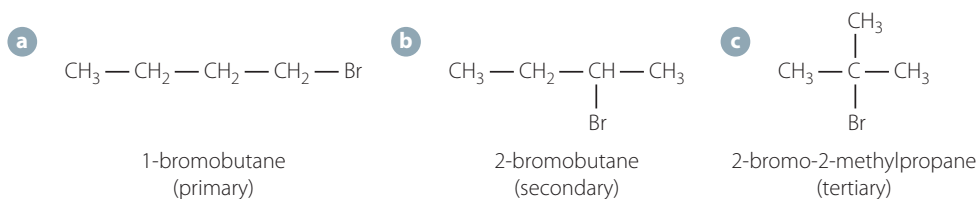
BOND	BOND ENERGY (kJ mol <sup>-1</sup> )
C—H	412
C—C	348
C—Cl	338
C—Br	276
C—I	238

All the C-X bond energies in Table 11.2 are lower than the C-C and C-H bonds allowing for the C-X bond to break and the haloalkane to react.

The bond energies also explain why haloalkanes with a C-I bond are more reactive than those with a C-Br or C-Cl bond. As the bond energy decreases, the bond is easier to break so the molecule is more reactive.

The C-F bond is an exception to this trend. Since the bond energy for C-F is 485 kJ mol<sup>-1</sup>, substantially higher than both the C-C and C-H bonds, **fluoroalkanes** will not undergo reaction with water to produce alcohols.

Haloalkanes, like alcohols, have primary, secondary and tertiary structures. A **primary haloalkane** has one carbon bonded to the carbon atom to which the halogen atom is attached. A **secondary haloalkane** has two carbons bonded to the carbon the halogen atom is attached. A **tertiary haloalkane** has three carbons bonded to the carbon atom to which atom to which the halogen atom is attached. Examples of primary, secondary and tertiary haloalkanes are seen in Figure 11.15.

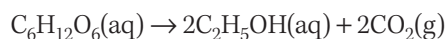


**FIGURE 11.5** Primary, secondary and tertiary haloalkanes

In this substitution reaction, tertiary haloalkanes are the most reactive, followed by secondary haloalkanes. Primary haloalkanes do react, but only very slowly since they are the least reactive.

## Production from fermentation

**Fermentation** is the process of converting simple sugars like glucose into ethanol in an anaerobic environment. The balanced equation for this is:

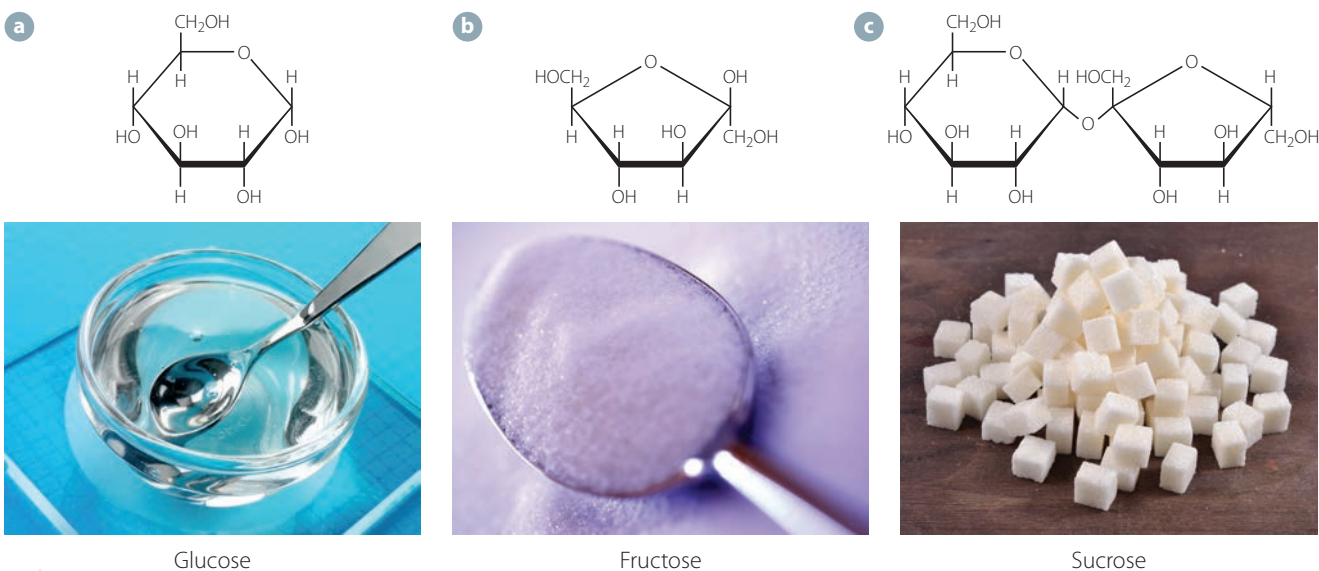


**Yeast**, in the absence of oxygen, convert glucose to ethanol. Glucose passes through the cell wall of the yeast where it is used by the organism to produce energy through normal metabolic pathways. Under specific conditions (lack of oxygen) the yeast will produce ethanol as a by-product of these processes. The ethanol is then excreted out of the yeast along with carbon dioxide.

Yeast can be found naturally on fruits like grapes, but most alcohol producers will add a cultured yeast that allows for better control of the rate of fermentation. This gives a more consistent, predictable product.

## Types of sugars

Yeast require simple sugars to convert to ethanol. Many fruits, including grapes, contain simple **monosaccharide** sugars like glucose and fructose. The structures of glucose, fructose and sucrose can be seen in Figure 11.16.



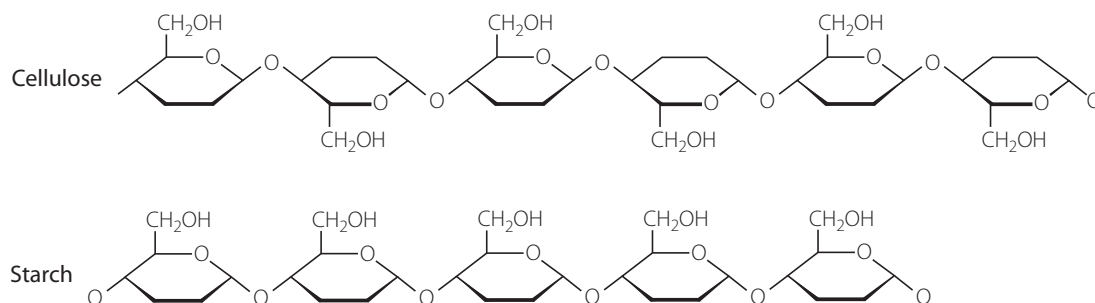
**FIGURE 11.6** Chemical structures and appearance of **a** glucose, **b** fructose and **c** sucrose



Glucose and fructose are monosaccharides (or simple sugars). They both have molecular formula  $C_6H_{12}O_6$  and are isomers of each other. Monosaccharides have a single ring structure of either four, five or six carbons. They also contain multiple hydroxyl groups.

Sucrose is a **disaccharide**, consisting of two carbon rings. Two monosaccharides join in a condensation reaction to produce disaccharides. Most fruits that are used to produce alcohol contain a mixture of these three sugars, plus other mono- and disaccharides like galactose and maltose.

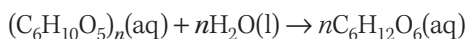
Many grains and vegetables are used to produce ethanol through fermentation. These contain either cellulose or starch, as seen in Figure 11.17. These are carbohydrates, also known as **polysaccharides**. Multiple monosaccharides and disaccharides join to form these structures. Starch and cellulose have the general formula  $(C_6H_{10}O_5)_n$ . The formula indicates the repeated structure and the  $n$  indicates multiple units are present. Polymers will be discussed in detail in chapter 13.



**FIGURE 11.7** Chemical structures of cellulose and starch

Yeast is most efficient at breaking down simple monosaccharide sugars. Most types of yeast are not able to break down polysaccharides at all, and can only break down sucrose in a limited manner. More complex sugars need to be broken down before they can be converted to ethanol. **Enzymes** present in the fermentation mixture can break down complex sugars into glucose.

Hydrolysis of polysaccharides to monosaccharides:



Hydrolysis of disaccharides to monosaccharides:



Once glucose has formed, it can be converted to ethanol by the yeast in the fermentation mixture.

## Conditions for fermentation

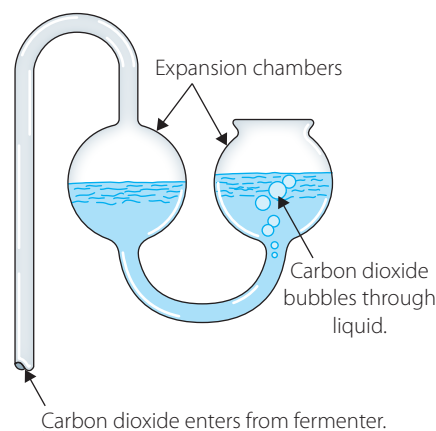
Very specific conditions are required for fermentation. Without these conditions it is nearly impossible to produce drinkable wine or spirits.

The temperature of the fermentation mixture must be kept low. For example, for red wine production the mixture cannot exceed  $29^\circ\text{C}$ , and for white wine the maximum temperature is only  $18^\circ\text{C}$ . The yeast and enzymes involved in fermentation are extremely temperature sensitive and will denature, or stop working, if temperatures are above or below a narrow range.

Enzymes and yeast are also very sensitive to pH. The ideal range of pH for fermentation is around 6.1–6.8 (slightly acidic). Enzymes will denature outside this range and fermentation will stop.

Fermentation occurs under **anaerobic** conditions; that is, no oxygen must be present. Oxygen will oxidise the ethanol to produce ethanal and ethanoic acid. Oxidation of ethanol to ethanoic acid results in the vinegar taste of wine that has been open for too long. Figure 11.8 shows a simple airlock that is used to keep oxygen out of the fermentation mixture. The liquid, usually water, allows the carbon dioxide produced to escape and not build up pressure inside the reaction vessel. The water also prevents oxygen entering the mixture.

The mixture must also be kept dilute, usually by adding water to dilute it periodically. The ethanol produced by the yeast will poison them if the concentration becomes too high. Yeast will be killed when the ethanol content reaches approximately 14% v/v. Keeping the mixture dilute is not an issue for the final product since the ethanol can be distilled off and concentrated at the end of the process.



**FIGURE 11.8** A simple airlock used to exclude oxygen from a fermentation mixture

## INVESTIGATION 11.3

### Measuring the rate of fermentation

#### AIM

To create a fermentation mixture and measure the rate of reaction.

#### MATERIALS

- 5 mL of  $0.1 \text{ mol L}^{-1}$  sodium dichromate solution ( $\text{Na}_2\text{Cr}_2\text{O}_7$ )
- 5 mL of  $6 \text{ mol L}^{-1}$  sulfuric acid ( $\text{H}_2\text{SO}_4$ )
- 250 mL conical flask
- 5 g yeast – dried packet yeast for bread-making will work for this investigation
- 10 g glucose – sucrose or table sugar will also work
- 40 mL warm water ( $30\text{--}40^\circ\text{C}$ )
- Spatula
- Electronic balance
- Controlled environment (incubator) set at around  $25\text{--}30^\circ\text{C}$
- Plastic hose
- One-hole rubber stopper
- Limewater (calcium hydroxide)
- Test tube
- Thermometer
- 5 mL measuring cylinder
- Disposable pipettes



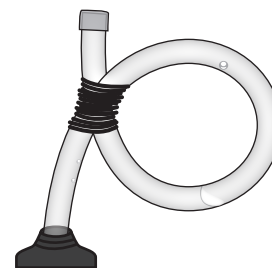


WHAT ARE THE RISKS IN DOING THIS INVESTIGATION?	HOW CAN YOU MANAGE THESE RISKS TO STAY SAFE?
Concentrated sulfuric acid is corrosive and emits harmful vapours.	Teacher may dispense acid as required. Avoid contact with skin by using appropriate personal protection equipment. Avoid inhalation of vapours by using chemicals in a fume cupboard.
Production of carbon dioxide gas could build up pressure.	Ensure gas leaves through airlock.
Ethanol is flammable.	Keep mixture clear of flame and hot equipment.

What other risks are associated with your investigation? How can you manage these?

#### METHOD

- 1 Place 5 g of yeast in the conical flask.
- 2 Add 10 g glucose and 40 mL warm water to the flask. Swirl to mix contents.
- 3 Stopper the conical flask and attach a simple airlock created by making a circle of a length of plastic tube and filling with water, as seen in Figure 11.9.
- 4 Measure the mass of the set-up and record.
- 5 Measure the mass of the fermentation set-up over the next 2–3 days, recording against the number of hours since set-up. If possible, store the mixture in a temperature controlled environment at approximately 25°C. Generally a classroom window will be sufficient to see results.
- 6 During one mass measurement, unwind the plastic tubing and bubble the gas produced through a solution of limewater, recording any observations.
- 7 After completion of mass measurements, extract approximately 5 mL of the fermentation mixture and add acidified dichromate solution, as used in Investigation 11.2 (page 325). Record any observations.



**FIGURE 11.9** A simple airlock can be made from a plastic hose partially filled with water.

#### RESULTS

Record the mass of the fermentation mixture against the number of hours of fermentation in a suitable table. Record observations of limewater and acidified dichromate ion tests.

#### DISCUSSION

- 1 Explain, using an equation, why there was a decrease in mass over time. Explain how this can be used to measure rate of fermentation.
- 2 Construct a graph of mass lost against hours of fermentation. Describe and explain any trends seen.
- 3 Explain the purpose of the limewater test. Use a balanced equation in your answer.
- 4 Explain the purpose of the acidified dichromate ion test. Use a balanced equation in your answer.

#### CONCLUSION

Write a conclusion summarising any trends found in this investigation.

- Alcohols can be produced by fermentation, hydration of alkenes, or substitution of haloalkanes.
- Haloalkanes undergo substitution reactions more easily than alkanes due to the lower bond energies of the C—X bonds compared to the C—C and C—H bonds.
- Fermentation is the conversion of simple sugars to ethanol using yeast.
- Complex sugars are broken down to simple sugars before fermentation occurs.
- Conditions required for fermentation include regulated temperature, specific pH, and an anaerobic, aqueous environment.

- 1 Write equations for:
  - a the addition of water to 1-pentene
  - b the addition of water to 2-methyl-1-butene
  - c the addition of water to 2-chloropropane
  - d the addition of water to 1-bromobutane
  - e the fermentation of glucose
  - f the conversion of a polysaccharide to a monosaccharide
  - g the reaction that occurs when a fermentation mixture is exposed to oxygen.
- 2 Explain why haloalkanes are more reactive than non-halogenated alkanes.
- 3 Explain why fluoroalkanes do not easily undergo substitution reactions.
- 4 Water is added to two alkanes: 2-methyl-2-chloropentane and 1-chloropropane. Identify which haloalkane will react more readily. Justify your answer.
- 5 Explain the role of yeast in fermentation.
- 6 Describe two specific conditions required for fermentation to occur.

## 11.6 Fuels from different sources

Fuel use in society has made our lives easier, providing us with cheap, reliable transportation, heating, cooking and electricity. However, there are also issues with fuel use including our dependence on fossil fuels, the decreasing levels of fossil fuels available and pollution, which is producing significant environmental consequences.

By 2040, production levels are estimated to be down to 15 million barrels per day, only 20 per cent of current daily consumption. It is also likely by then that demand will have increased substantially due to population increases and more industrial development in second and third world countries.

This means new sources of fuel are needed to supplement and eventually replace the fossil fuels we currently depend on. A major source of **alternative fuels** other than fossil fuels are **biofuels**, such as ethanol and biodiesel.

### Fossil fuels

Fossil fuels are currently the primary source of fuel in society. Fossil fuels are produced over millions of years from decayed animal and plant matter. Coal, crude oil and natural gas are all fossil fuels. Since these fuels have not been produced from recent organic sources, they are not considered to be biofuels.

As previously discussed, the combustion of fossil fuels provides huge amounts of energy that is captured to generate electricity, power automobiles, cook food and heat our homes. However, this combustion also leads to environmental problems like the enhanced greenhouse effect due to emission of carbon dioxide. These issues were discussed in chapter 10.

### Biofuels

Biofuels are produced from renewable sources such as crops rather than from fossil fuels. Biofuels are classified as renewable sources of fuels because they can be continuously produced from crops, algae or animal wastes. The two main biofuels used in Australia are ethanol and **biodiesel**. Ethanol is only used in Australia as a fuel additive, E10, which is a mixture of unleaded fuel and 10 per cent ethanol.



Ethanol as a fuel

## Ethanol

The production of ethanol was covered earlier in this chapter. The main methods of production are through fermentation, or industrially through hydration of alkenes or haloalkanes. The most common method for the production of ethanol in beverages and vehicle fuel additives is fermentation. This process is increasingly being used to produce fuel alcohol and, since 2007, Australia has more than tripled its production of fuel ethanol through the fermentation process.

Bioethanol is produced from agricultural crops like corn, sorghum, wheat and sugar cane, such as at the distillery shown in Figure 11.10. It can also be produced from biomass like vegetable waste. Using crops to produce ethanol is somewhat controversial given the food shortage in some parts of the world. Agricultural land used to produce ethanol for fuel is land that cannot be used for growing food. In some countries, it has resulted in increased land clearing to produce extra crops for ethanol production.

Ethanol, when compared to petrol, has approximately 34 per cent less energy per volume. However, ethanol has a higher **octane rating** (measure of the level of compression the fuel can undergo before igniting), which makes it a higher performance fuel. Higher performing fuels are more efficient and burn more cleanly than lower performing fuels. Overall, considering all properties, E10 fuel (a mix of petrol and up to 10 per cent ethanol) has only slightly lower fuel economy than regular petrol. This means there is not a significant difference between the distance a car will travel on a tank of E10 compared to a tank of unleaded petrol without ethanol.

Ethanol, when combusted, releases less carbon dioxide than the same amount of regular petrol. When you also consider that the carbon dioxide released was only recently removed from the environment by photosynthesis of the crops used to make the ethanol, the overall net release of carbon dioxide is significantly reduced. Estimates vary based on the crops used and production methods, but carbon dioxide emissions from ethanol combustion can be between 20 and 50 per cent lower than for the same amount of fossil fuel combustion.

**FIGURE 11.10**

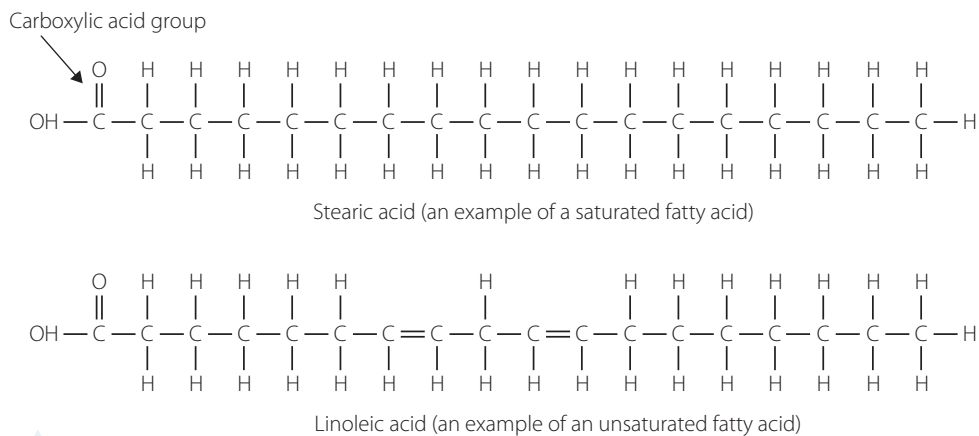
Part of Wilmar's bioethanol distillery in North Queensland, producing 60 million litres of bioethanol per year



## Biodiesel

Biodiesel can be produced from almost any fatty acid, including corn, palm, coconut, sunflower and peanut oils.

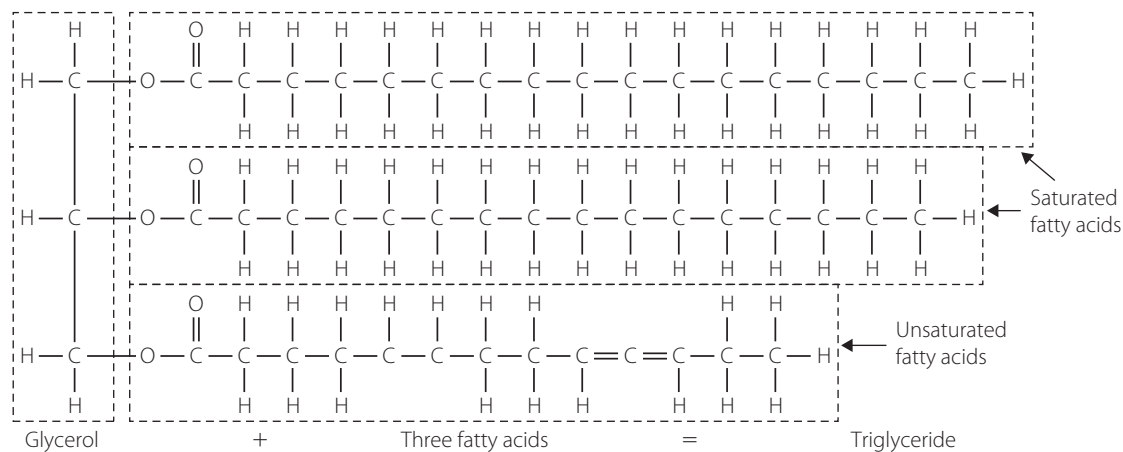
**Fatty acids** are long chain carboxylic acids. The chain can be saturated or unsaturated, and usually contains an even number of carbon atoms (between 4 and 28). Figure 11.11 shows the structure of a saturated and an unsaturated fatty acid.



**FIGURE 11.11** Examples of saturated and unsaturated fatty acids

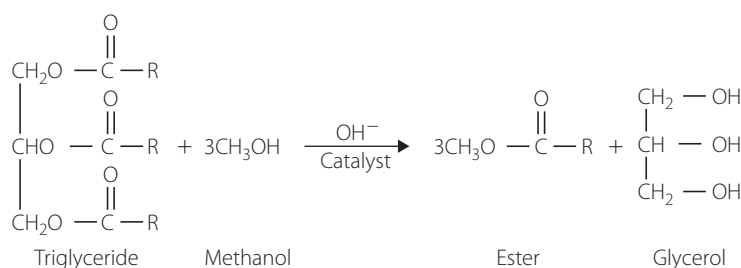
Most biodiesel currently produced uses waste vegetable oil from restaurants and industrial food producers, which keeps costs down and the fuel can compete financially with fossil fuel based diesel.

Diesel is a fuel with a range of alkanes with long hydrocarbon chains of 8–21 carbons. Biodiesel is similar, but contains an ester group, and is formed from the breakdown of triglycerides. **Triglycerides** are plant or animal fats, each of which contain three fatty acid chains connected to a glycerol molecule, as seen in Figure 11.12. **Glycerol** is an alcohol with three hydroxyl groups and the systematic name 1,2,3-propantriol.



**FIGURE 11.12** Triglycerides are made from glycerol and three fatty acid molecules.

Triglycerides are reacted with short chain alcohols, usually methanol or ethanol, to produce an ester (the biodiesel) and glycerol. This process is called **transesterification**. The reaction with methanol is shown below.





Once the reaction is complete, the two products are gravity-separated because the glycerol is denser than the biodiesel. The biodiesel is purified and is ready for use.

A catalyst is used in the production of biodiesel to facilitate a rapid reaction rate. Catalysts can be acids, bases or enzymes (biological catalysts).

Almost all biodiesel production uses a strong base, often sodium or potassium hydroxide. This method is effective because it is the most economical, has a 98 per cent conversion yield, and requires low temperatures. However, it produces high temperatures, which are safety risks, and forms soap as a by-product, which reduces the yield of the ester. It is also expensive to purify the glycerol due to the presence of the base.

Alternatively, an enzyme can be used. Lipase catalyses the breakdown of fats and thus it can be used to increase the rate of the reaction. This method overcomes the problem of soap production and therefore enables a higher yield of biodiesel. However, the enzymes are expensive to produce.

Biodiesel of up to 20 per cent mixture with regular diesel can be used in vehicles without modification. With engine modification, 100 per cent biodiesel can be used without performance or maintenance issues for the vehicle. Biodiesel is increasingly being tested and used in aircraft, trains and heavy vehicles with many manufacturers developing and producing engines that can accommodate high percentages of biodiesel.

The energy produced by combustion of biodiesel is around 9 per cent lower than regular diesel, with variations based on the fats and oils used to produce it. Factoring in differences in flashpoint (higher for biodiesel), viscosity and heating values, there is little difference in fuel efficiency between biodiesel and regular diesel. This comparison is summarised in Table 11.3.

Biodiesel, like bioethanol, produces less carbon dioxide overall than regular diesel, again because the fats and oils used to produce it only recently removed carbon dioxide from the atmosphere. Release through combustion only contributes a small net amount of carbon dioxide from the production process.



Comparing fuels

## Comparison of fuels from different sources

**TABLE 11.3** A comparison of some features of fossil fuels and biofuels

PROPERTY	FOSSIL FUELS	BIOFUELS
Chemical composition	Coal (C) Natural gas (primarily CH <sub>4</sub> ) Petrol/diesel (primarily alkane chains of varying length)	Ethanol (C <sub>2</sub> H <sub>5</sub> OH) Biodiesel (esters of varying chain length)
Source	Mining	Ethanol – agricultural crops (sugar cane, wheat, etc.) Biodiesel – fats and oils
Enthalpy of combustion (kJ g <sup>-1</sup> )	Natural gas (53.6) Coal (9.8–27.9) Petrol (48) Crude oil (44.9–46.3) Diesel (42.6)	Biodiesel (37.2) Bioethanol (29.6) Values vary depending on source of crops used for production
Emission of CO <sub>2</sub>	High net release during both production and use (combustion)	Lower net release during combustion since recently removed from atmosphere through photosynthesis Some release associated with production
Vehicle modification required	None	Modification of vehicles to use higher percentages of ethanol or biodiesel
Running costs	No modifications required; fuel more expensive than biofuels, but similar to hydrogen	Ethanol – no modification required for vehicle use up to 10 per cent; fuel cheaper than regular petrol Biodiesel – no modification for up to 20 per cent vehicle use; modification required for 100 per cent use; fuel cheaper than regular diesel

- Fossil fuels are the primary source of fuel in society, but have decreasing levels available, while demand is increasing.
- Biofuels including ethanol and biodiesel are produced from renewable sources.
- Ethanol for use as a fuel is produced through fermentation of crops and combined with petrol to make E10 fuel.
- Biodiesel is made from fats and oils and contain an ester group rather than the alkane structure of regular diesel.
- Biodiesel is made in a process called transesterification.
- Biofuels are developing as alternatives to fossil fuels.
- Biofuels have advantages over fossil fuels, but also have some issues around cost and vehicle modification requirements.



Check your understanding

- 1 Describe the use of fuels in society.
- 2 Explain the need for development of alternative fuels like biofuels and hydrogen.
- 3 Define 'biofuel'.
- 4 Describe the production of bioethanol when produced as a fuel additive.
- 5 Identify advantages and disadvantages of fuels containing ethanol when compared to fuel without ethanol as an additive.
- 6 Draw the structures of a fatty acid and a fat/oil.
- 7 Describe, including equations, the production of biodiesel.
- 8 Identify advantages and disadvantages of biodiesel when compared to regular fuel.

CHECK YOUR  
UNDERSTANDING

11.6

## IMPORTANT NEW TERMS

After studying this chapter you should know the meaning of the following terms:

alkyl halide (p. 322)

alternative fuel (p. 333)

anaerobic (p. 331)

biodiesel (p. 333)

biofuel (p. 333)

bond energy (p. 328)

calorimetric (p. 317)

calorimetry (p. 316)

disaccharide (p. 330)

enthalpy of combustion (p. 317)

enzyme (p. 330)

fatty acid (p. 334)

fermentation (p. 329)

fluoroalkane (p. 328)

glycerol (p. 335)

haloalkane (p. 328)

monosaccharide (p. 329)

octane rating (p. 334)

polysaccharide (p. 330)

primary/secondary/tertiary haloalkane (p. 328)

substitution reaction (p. 328)

transesterification (p. 335)

triglyceride (p. 335)

yeast (p. 329)

AFTER STUDYING THIS CHAPTER  
YOU SHOULD KNOW:

- ▶ the definitions for all terms in the important new terms list
- ▶ the general equations for the combustion, dehydration, HX substitution and oxidation of alcohols
- ▶ how alcohols are produced by alkene hydration, haloalkane substitution and fermentation
- ▶ the conditions required for fermentation
- ▶ the general equations for the oxidation of primary and secondary alcohols
- ▶ tests to distinguish between primary, secondary and tertiary alcohols
- ▶ how biofuels, including ethanol and biodiesel, are produced
- ▶ advantages and disadvantages of fossil fuels and biofuels.

## YOU SHOULD BE ABLE TO:

- ▶ outline a method to conduct an investigation comparing the enthalpy of combustion of various alcohols
- ▶ calculate enthalpy of combustion values for fuels in  $\text{kJ mol}^{-1}$  and convert to units of  $\text{kJ g}^{-1}$  and  $\text{kJ L}^{-1}$
- ▶ predict products and write equations for the combustion, dehydration, HX substitution and oxidation of alcohols
- ▶ outline a method to create a fermentation mixture and measure the rate of fermentation
- ▶ predict products and write equations for the production of alcohols by alkene hydration, haloalkane substitution and fermentation
- ▶ predict products and write equations for the oxidation of primary and secondary alcohols
- ▶ write equations for the production of biodiesel from triglycerides
- ▶ compare and contrast fossil fuels with biofuels like bioethanol and biodiesel.

# 11 CHAPTER REVIEW QUESTIONS



Review quiz

- Biofuels are increasingly being produced in Australia.
  - Describe how a biofuel is different to a fossil fuel.
  - Name two important biofuels currently in use in Australia.
- Outline a procedure that could be used to measure the enthalpy of combustion of 1-butanol. You should include a labelled equipment diagram, possible risks and all measurements that need to be recorded.
- For the experiment you described in question 2:
  - identify two major sources of error
  - explain the effect on the calculated enthalpy of combustion from the experiment
  - describe any steps you could take to minimise the effect of these errors.
- Write equations to show:
  - the dehydration of 1-propanol
    - the dehydration of 3-methyl-1-pentanol
    - the reaction of 2-butanol with hydrogen bromide
    - the reaction of 2-methyl-2-pentanol with hydrogen chloride
    - the reaction of 2-methyl-2-bromobutane with water
    - the reaction of 1-chloroethane with water.
  - Name all organic products in the reactions you wrote in part a.
- Write organic structural equations (not full balanced equations) for the oxidation of:
  - 2-propanol
  - 1-butanol
  - 2-methyl-1-pentanol
  - 2-methyl-3-hexanol.
- Write redox half reactions to show the reduction of dichromate ions and permanganate ions. Explain how these reactions can be used to visually test for the presence of a primary alcohol.
- You are given a sample of 1-pentanol and a sample of 2-methyl-2-pentanol. Both are colourless liquids but the labels have been removed.
  - Outline an experiment you could perform to distinguish between the two compounds.
  - Describe the observations you would make.
  - Explain how these observations allow you to tell the two compounds apart.
- Ethanol is produced through the substitution of halogenated organic compounds and by fermentation.
  - Write equations to show the production of ethanol using both methods.
  - Describe any conditions necessary for each production method.
  - Explain which method produces a biofuel.
- Biodiesel is a fuel produced using waste oils and fats. Stearic acid is a fatty acid with formula  $\text{CH}_3(\text{CH}_2)_{17}\text{COOH}$ .
  - Draw the triglyceride made entirely from stearic acid.
  - Explain whether this is a saturated or unsaturated triglyceride.
  - Write an equation for the formation of biodiesel made from the triglyceride in part b, using methanol.
  - What is the name given to the process in part c?
- Calculate the heat released per gram from the combustion of the following fuels (enthalpy of combustion in  $\text{kJ mol}^{-1}$  are given in brackets).
  - Hydrogen (285)
    - Ethanol (1360)
    - Octane (5460)
    - Sucrose ( $\text{C}_{12}\text{H}_{22}\text{O}_{11}$ ) (5650)
  - Explain why conversion to  $\text{kJ g}^{-1}$  is useful.
  - Rank these fuels in terms of increasing heat released.
    - Per mole
    - Per gram
  - Propose reasons for any differences in rankings in part c.
- A mass of 0.72 g 1-butanol ( $\text{C}_4\text{H}_9\text{OH}$ ) is burnt with excess oxygen and used to heat 500 g of water with initial temperature  $15.9^\circ\text{C}$ . When the water was at a temperature of  $29.0^\circ\text{C}$ , the reaction was stopped. Calculate the enthalpy of combustion of 1-butanol.
- The heat of combustion of ethanol is  $1360\text{ kJ mol}^{-1}$ . Calculate the mass of ethanol that needs to be combusted to raise the temperature of 350 g water by  $77^\circ\text{C}$  if 55 per cent of the heat produced by combustion is lost to the environment.

- 13** The heats of combustion of liquid octane and liquid propane are  $5460$  and  $2200 \text{ kJ mol}^{-1}$  respectively. Assume that petrol is pure octane with a density of  $0.70 \text{ g mL}^{-1}$  and liquid propane is pure propane with a density of  $0.49 \text{ g mL}^{-1}$ .
- a** Calculate the heat released by the combustion of  $1.00 \text{ L}$  petrol.
  - b** Calculate the volume of liquid propane that needs to be burnt to produce this same amount of heat.
  - c** If petrol sells at  $\$1.45$  per litre, what would the price of liquid propane per litre need to be to have the same price in cents per kilojoule as petrol?
- 14** Samples of 2-methyl-2-bromopropane and 1-chloropropane are added to water. Explain which compound will be more reactive.
- 15** Explain, using bond energies, why:
- a** haloalkanes are more reactive than alkanes
  - b** fluoroalkanes are very difficult to react.
- 16** Grapes, which contain glucose, are acted upon by yeast to produce ethanol. Vegetables and grains contain starch and cellulose. Compare the process of fermentation of grapes and grains, using balanced equations in your answer.
- 17** Describe two advantages and two disadvantages of biofuels over conventional fuels such as petrol and diesel.

# 12

## Reactions of organic acids and bases

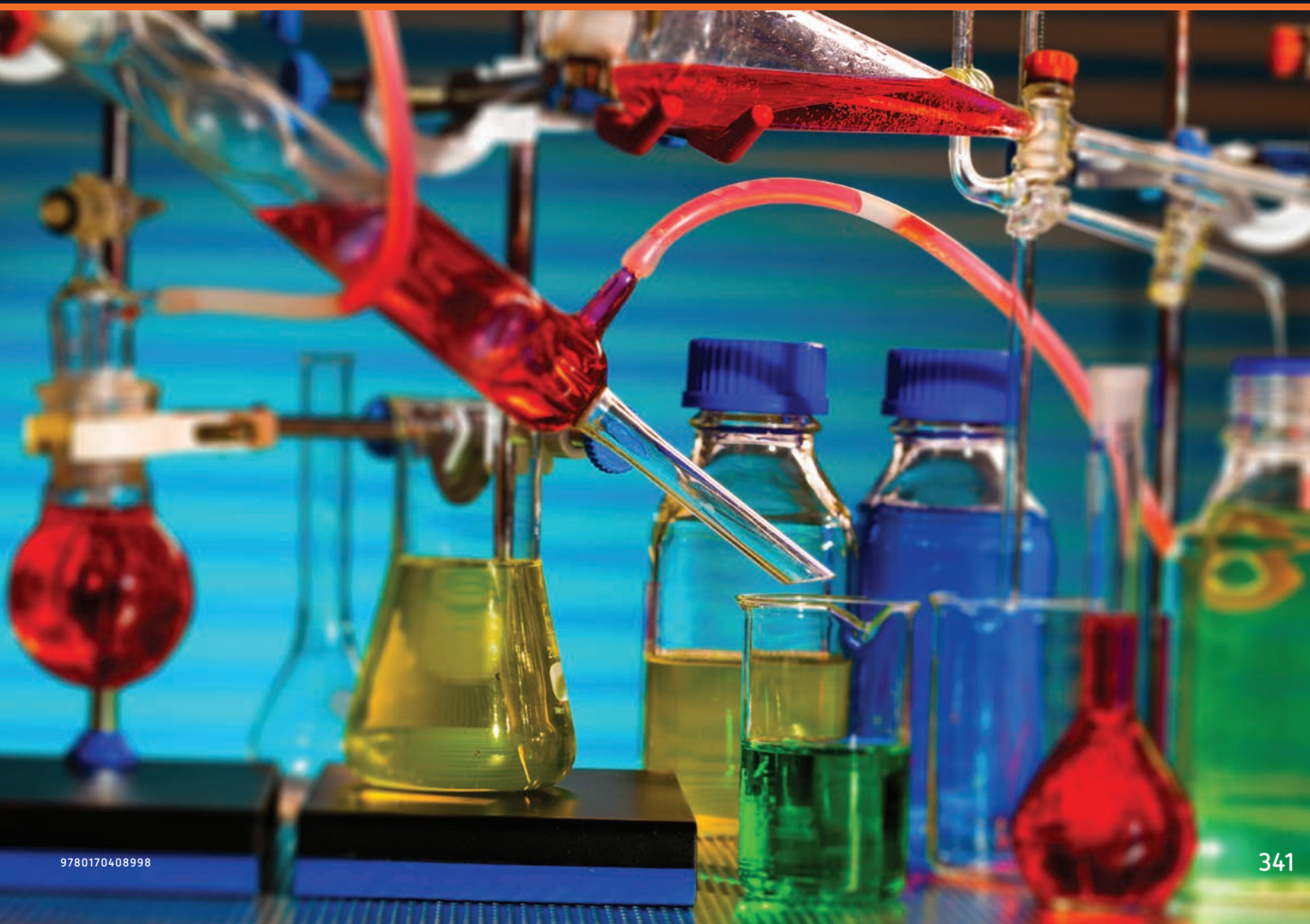
### INQUIRY QUESTION

What are the properties of organic acids and bases?

### Students:

- investigate the production, in a school laboratory, of simple esters
- investigate the differences between an organic acid and organic base
- investigate the structure and action of soaps and detergents
- draft and construct flow charts to show reaction pathways for chemical synthesis, including those that involve more than one step. [ICT](#)

Chemistry Stage 6 Syllabus © NSW Educational Standards Authority for and on behalf of the Crown in right of the State of New South Wales, 2017







Prior knowledge



**FIGURE 12.1** Many common acids are organic acids, including citric, ascorbic (vitamin C) and ethanoic acids.

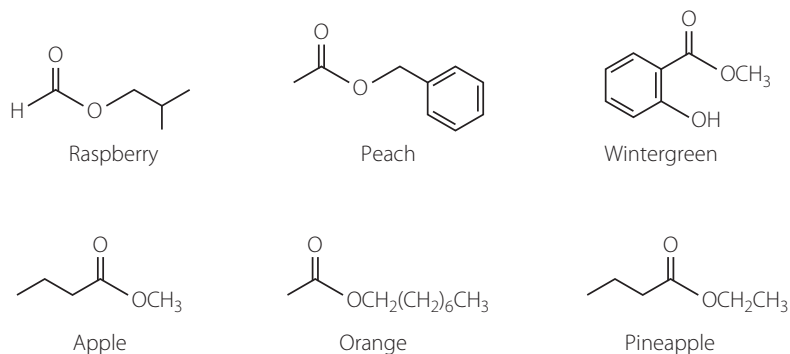
Many organic compounds can act as acids and bases. In chapter 5 you looked at properties of inorganic acids and bases including hydrochloric acid, sulfuric acid, sodium hydroxide and potassium oxide. Organic acids, like ethanoic (acetic) acid, citric acid and lactic acid, share many of the properties of acids you have studied. Likewise, organic bases including amines behave as other bases do.

Organic acids and bases play a part in many useful reactions, several of which will be covered in this chapter. Esters and soaps are two important compounds used in the manufacture

of foods (esters) and cleaning materials (soaps). Organic acids are also found in medicines and foods, while organic bases are found in DNA, amino acids and used to manufacture pesticides, solvents and some medicines. Indigenous Australians used many naturally occurring organic acids and bases found in plants as medicines and to treat a variety of conditions.

## 12.1 Esters

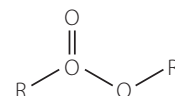
Esters are an important group of organic compounds found in a wide range of biological systems (Figure 12.2). They have pleasant fruity odours and are responsible for the flavours and fragrances of many fruits and flowers. Solid animal fats and animal and vegetable oils are natural esters.



**FIGURE 12.2** The flavours associated with many foods come from esters.

As well as being widespread in nature, esters are commonly used in industry. Esters can be synthesised easily and they are produced synthetically for use as artificial flavouring and colourings. Several billion kilograms of **polyesters** are produced annually to make a wide variety of products, including fabrics and plastic bottles.

Esters have a similar structure to carboxylic acids, except that an alkyl group is attached to the oxygen rather than a hydrogen atom. The general formula for an ester is seen on the right.



The R and R' in the formula on the previous page represent alkyl groups.

An example of an ester is shown in Figure 12.3. This ester is found in pineapples, peaches and apricots. The ester group formed is also referred to as an ester link. The ester link joins the alcohol and carboxylic acid that react to produce the ester.

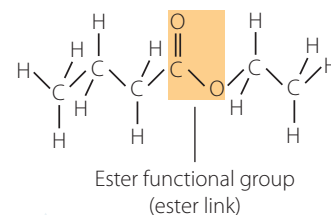
## Naming esters

The names of esters are two words based on the structure seen in Figure 12.4.

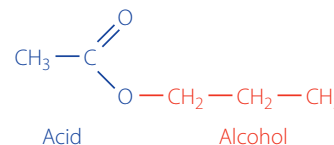
- 1 The first part of the name is the alkyl group directly attached to the oxygen of the ester group (right side of Figure 12.4). Originally, this part of the ester was the alcohol molecule it formed from. It is given the name in alkyl form; for example, one carbon is methyl, four carbons is butyl, six carbons is hexyl. In Figure 12.4, there are three carbons in this part of the molecule, so it is propyl.
- 2 The second part of the name comes from the carboxylic acid used in the ester formation. In Figure 12.4, this is the hydrocarbon component on the left side of the molecule. Be sure to include the carbon that is part of the ester group in this part of the name. The end of the acid name is changed from -oic acid to -oate. Figure 12.4 shows two carbons in this part of the molecule, so it is ethanoate (from ethanoic acid.)

Overall, the molecule has the name propyl ethanoate.

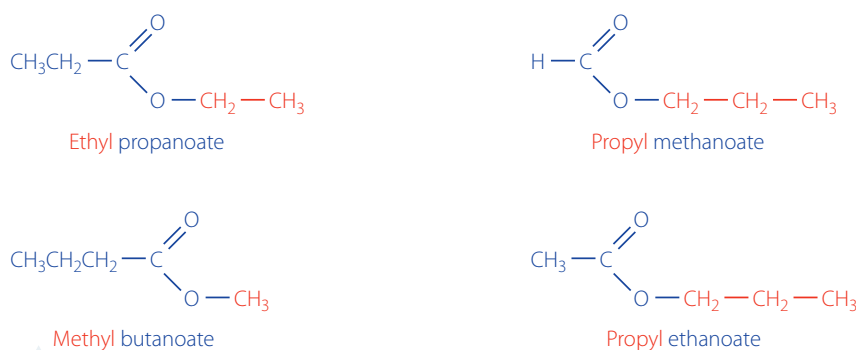
Figure 12.5 shows further examples of ester names related to their structure. Table 12.1 (page 344) lists formulae and properties of some common esters.



**FIGURE 12.3** The ester, ethyl butanoate



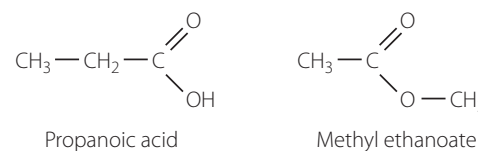
**FIGURE 12.4** The name of an ester comes from the two alkyl groups on either side of the ester group.



**FIGURE 12.5** Naming esters through their structure

In chapter 9, you learnt that aldehydes and ketones were functional group isomers. Aldehydes and ketones share the same molecular formula but have different functional groups.

Carboxylic acids and esters are also functional group isomers. For example, the molecular formula of both propanoic acid and methyl ethanoate is  $C_3H_6O_2$ , while their structural formulae are shown here on the right.



## Properties of esters

The presence of the C—O and C=O makes the ester group polar. However, esters tend to be liquids at room temperature and their boiling points are much lower than for carboxylic acids of similar mass. This is because their main intermolecular forces are dipole–dipole forces, which are weaker than the hydrogen bonding in carboxylic acids and alcohols.

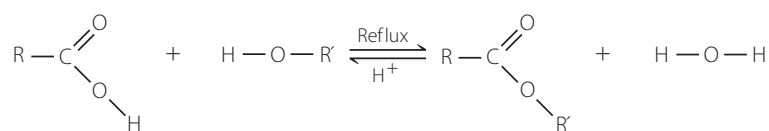
Most esters are not very soluble in water due to the lack of hydrogen bonding and the presence of large hydrophobic alkyl groups. However, they are soluble in organic solvents. Many esters are thus used as solvents in industry. For example, ethyl ethanoate is a common solvent in nail polish remover.

**TABLE 12.1** Formula and properties of some common esters

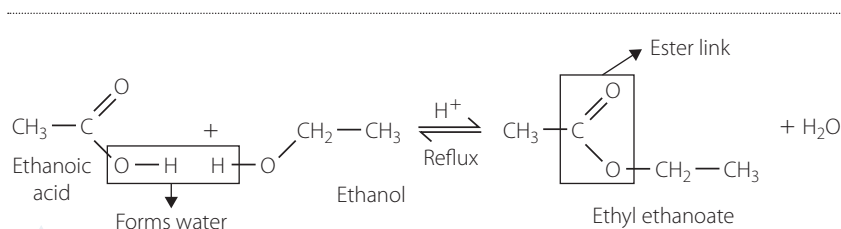
NAME	FORMULA	MOLECULAR MASS (g mol <sup>-1</sup> )	BOILING POINT (°C)	SOLUBILITY IN WATER (g/100 g WATER)
Methyl methanoate		60	32	24
Methyl ethanoate		74	57	6.7
Methyl propanoate		88	80	7.3
Ethyl ethanoate		88	77	7.5
Propyl ethanoate		102	102	2

## 12.2 Preparing esters

Esters are produced by the reaction between an alcohol and a carboxylic acid. The general reaction is:



Note that in this reaction a water molecule is produced. A reaction in which the functional groups of two molecules join and a small molecule is released is called a **condensation reaction**. Figure 12.6 shows the reaction between ethanoic acid and ethanol to produce ethyl ethanoate and water.

**FIGURE 12.6** Formation of the ester, ethyl ethanoate

## Conditions for preparing esters

Ester formation is a very slow process. In nature, reactions that form esters can take months or years. To prepare an ester in a laboratory, the rate of the reaction can be increased by adding concentrated sulfuric acid to the reaction mixture. The acid acts as a catalyst, speeding up the reaction and allowing it to occur in a much shorter period of time.

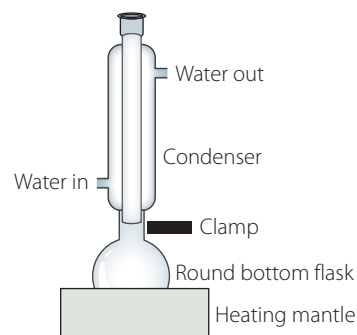
The mixture is also heated to increase the rate of reaction. Conventional heating of the mixture, in an open container on a hotplate or Bunsen burner will result in loss of the reaction mixture. The organic chemicals used in ester formation are volatile and will evaporate even when low heat is applied.

In ester formation, a process called **reflux** is used. The apparatus for refluxing is shown in Figure 12.7.

Reflux is a process in which reactants are heated for an extended period of time without any loss of reactants or products. As the reaction mixture is heated, the volatile components evaporate and move into a vertical condenser where the gases are cooled so they return to the reaction mixture in the flask. Since refluxing in a laboratory can take anywhere from 20 minutes to several hours, this means that the final yield of the ester is increased since none of the reaction mixture escapes.

Heating organic chemicals for an extended period can pose safety risks. The organic chemicals used can be highly flammable and are easily evaporated. There is also some risk of chemicals escaping the equipment. With these possibilities, use of a naked flame from a Bunsen burner should be avoided if possible by using a **heating mantle**. A heating mantle is designed to provide heat without a flame.

Another method of increasing the yield of the final ester is to add one reagent in excess. This will drive the equilibrium reaction to the right by Le Chatelier's principle, resulting in a higher percentage of ester produced.



**FIGURE 12.7** Apparatus used for refluxing an ester mixture

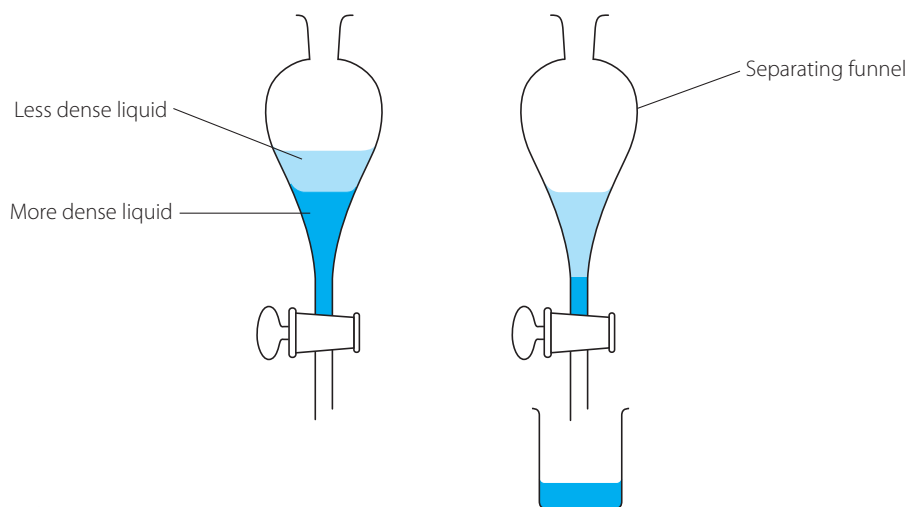
## Purifying an ester

Once reflux has been performed for about 30 minutes, the flask will contain a variety of organic and inorganic substances. Since it is an equilibrium reaction, there will be a mixture of both reactants and products, as well as the catalyst used (Table 12.2).

**TABLE 12.2** Components of a reflux mixture

ORGANIC COMPONENTS	INORGANIC COMPONENTS
Ester (product) – not very soluble in water, if at all	Water (as a product of the reaction and from any solutions added)
Carboxylic acid (leftover reactant) – soluble in water if small, most not fully soluble in water	Sulfuric acid (present in ion form $\text{H}^+$ and $\text{SO}_4^{2-}$ ) – soluble in water due to formation of ion-dipole bonds
Alcohol (leftover reactant) – soluble in water if short chain; long chain alcohols are not soluble in water	

A **separating funnel**, shown in Figure 12.8 (page 346), is used to separate **immiscible** substances during the ester purification process. Immiscible liquids do not dissolve in each other and separate into two layers, with the less dense layer on top. When the stopcock at the base of the funnel is opened, the denser component runs into a beaker, leaving the less dense component in the funnel.



**FIGURE 12.8** A separating funnel is used to separate liquids of different densities.

Purification of an ester requires a number of steps.

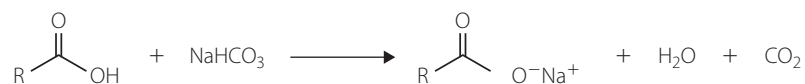
- 1 Washing with water to remove water soluble substances. The entire mixture from the reaction flask is poured into a separating funnel and water is added. After being left to stand, the mixture separates into two layers.

The organic layer contains the ester, and may also contain the alcohol and carboxylic acid if they are long-chain molecules. Even short-chain molecules may appear in the organic layer in trace amounts. Since the organic substances are usually less dense than water, the organic layer will be the top layer. One way to check the aqueous and organic layer is to add 1–2 drops of water. Water drops will pass through the organic layer and dissolve in the aqueous layer. Always check which layer is the organic layer before proceeding.

The aqueous layer contains water, sulfuric acid and any soluble short-chain alcohol and carboxylic acid molecules.

The two layers are separated and the aqueous layer is discarded.

- 2 Addition of sodium carbonate or sodium hydrogen carbonate to remove any carboxylic acid. Any insoluble carboxylic acid that is present will react with the carbonate ions to produce a **carboxylate ion** ( $\text{RCOO}^-$ ) and carbon dioxide gas:



The carbon dioxide gas will escape out of the top of the separating funnel. Do not stopper the funnel or gas will build up inside the container. The insoluble carboxylic acid is converted to a soluble carboxylate ion. The carboxylate ion is soluble due to its ability to form ion–dipole bonds with water, making it soluble despite its large hydrocarbon chain.

Water is added to the separating funnel, and it will again separate into an aqueous and organic layer. The layers are separated and the aqueous layer can be discarded.

- 3 Distillation to isolate the ester. Due to the different boiling point of the ester compared to other possible contaminants, distillation can be used to isolate the ester. By knowing the boiling points of the different components (carboxylic acid, ester, alcohol) the ester can be collected at the correct temperature, producing a pure final substance.

## INVESTIGATION 12.1

### Preparing simple esters

#### AIM

To make and purify an ester. A simple ester to make is pentyl ethanoate; however, depending on the alcohols and carboxylic acids available, you could attempt to make another ester.

#### MATERIALS

- 10 mL 1-pentanol (or other alcohol)
- 12 mL glacial ethanoic acid (or other carboxylic acid)
- 1 mL concentrated sulfuric acid
- 15 mL of 1.0 mol L<sup>-1</sup> sodium carbonate
- Deionised water
- 2 × 100 mL beakers
- 10 mL measuring cylinder
- Round bottom flask
- Condenser
- Boiling chips
- Plastic tubing
- Heating mantle or Bunsen burner
- Separating funnel
- Waste container for all organic waste
- Retort stand
- Boss head and clamps
- Matches
- Safety glasses

WHAT ARE THE RISKS IN DOING THIS INVESTIGATION?	HOW CAN YOU MANAGE THESE RISKS TO STAY SAFE?
Organic chemicals can be flammable.	Use a heating mantle instead of a Bunsen burner if possible. Keep all organic chemical storage containers away from flame.
Vapours from organic chemicals can be toxic.	Keep containers stoppered if possible. Perform experiment in well-ventilated room or in fume cupboard, if possible.
Gases can build-up in glassware during reflux and purification.	Do not stopper the top of the condenser during reflux or during addition of carbonate ions to the separating funnel.
Concentrated sulfuric acid is corrosive and emits harmful vapours.	Teacher to dispense acid. Kept in the fume cupboard when not in use. PPE to be worn when handling the acid.



What other risks are associated with your investigation? How can you manage these?

#### METHOD

- Place the pentanol, ethanoic acid, sulfuric acid and a few boiling chips into the round bottom flask and clamp securely.
- Assemble the reflux apparatus as seen in Figure 12.7 (page 345) ensuring both the flask and condenser are securely clamped and tightly fitted together.
- Connect the tubing to the tap and condenser and turn on water so a uniform flow is achieved.
- Heat the mixture with a heating mantle at a constant rate for approximately 30 minutes. Ensure the mixture is not heated too much or the vapours will escape out of the top of the condenser.
- Let the mixture cool then decant the entire mixture (without boiling chips) into a large separating funnel containing 15 mL water.
- Stopper the funnel and shake. Allow the layers to separate. Drain off and discard the aqueous layer.
- Add approximately 15 mL sodium carbonate solution and let most of the gas escape out of the top of the funnel.
- Once gas production has slowed, stopper and shake and then quickly take the stopper out to let the gas escape. Repeat until gas production stops.
- Add 10 mL deionised water, shake, allow layers to separate, drain and discard the aqueous layer.





- » 10 If time permits, you can distil your final ester. Research its boiling point and collect all liquid formed a few degrees either side of this temperature.
- 11 Make observations about the smell, volume, colour, viscosity and any other observable properties of your ester.

### RESULTS

Record your observations.

### DISCUSSION

- Write a balanced equation for the formation of your ester, naming all reactants and products.
- Explain the purpose of refluxing the ester mixture.
- Explain, in terms of polarity, the chemistry behind the purification of the ester using the separation funnel.
- Explain, including a balanced equation, the reason for adding sodium carbonate to the ester mixture during the purification process.
- Since the reactants react in equimolar quantities, what is the purpose of adding one reactant in excess?
- By considering the whole method (refluxing and purification) suggest reasons for:
  - the ester having a lower yield than theoretically possible
  - the final ester being contaminated with other substances.

### CONCLUSION

Write a conclusion assessing the suitability of this experiment to produce a pure ester.



Esters

- Esters have general formula  $R-COO-R'$  and are formed by the reaction between an alcohol and a carboxylic acid, involving refluxing (extended heating) and a sulfuric acid catalyst.
- Esters are named for the alcohol and carboxylic acid from which they are formed.
- Esters and carboxylic acids are functional group isomers.
- Esters are not very soluble in water and have lower boiling points than carboxylic acids and alcohols of similar molecular mass.
- Esters can be purified based on the differing polarities of the substances in the final equilibrium mixture.

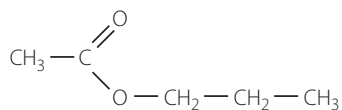
### CHECK YOUR UNDERSTANDING

12.1

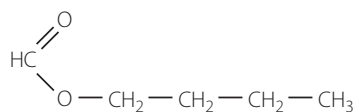
12.2

- Draw the ester functional group.
- Name the following compounds.

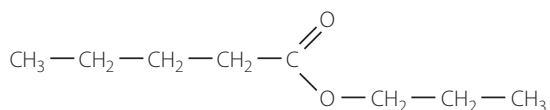
a



b



c

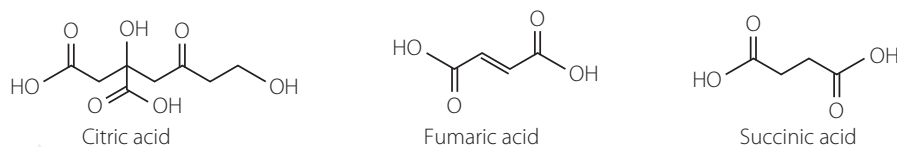


- 3 Draw structural formulae for:
- ethyl propanoate
  - propyl methanoate
  - butyl ethanoate.
- b For the ester in part i, circle and label the ester link.
- c For the ester in part ii, circle and label the part of the ester that comes from an alcohol.
- 4 Draw the structural formulae for three esters of molecular formula  $C_4H_8O_2$  and name them.
- 5 Write equations for the formation of esters when the following are added together.
- Ethanol and butanoic acid
  - 1-pentanol and methanoic acid
  - 1-propanol and pentanoic acid
- b Name each ester you have drawn in part a.
- 6 Explain the need for the following to produce a simple ester in the laboratory.
- Sulfuric acid catalyst
  - Reflux
- 7 Explain the reason, using equations where appropriate, for the following steps in ester purification.
- Washing the final reaction mixture with water in a separating funnel
  - Addition of sodium carbonate to the reaction mixture in the separating funnel

## 12.3 Organic acids and bases

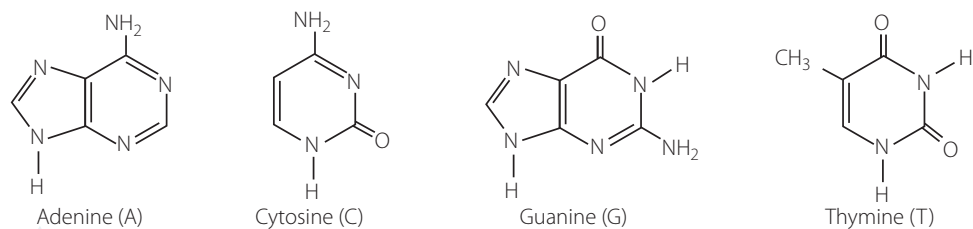
The most common **organic acids** are carboxylic acids. There are others but they are not covered in this course.

Organic acids include simple, straight chain carboxylic acids like methanoic and ethanoic acid, and also more complex acids like citric acid (citrus fruits), fumaric acid (food additive) and malic acid (fruits and used as a food additive) (Figure 12.9).

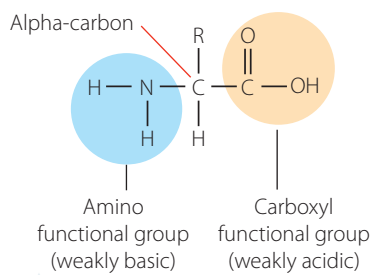


**FIGURE 12.9** Examples of organic acids

**Organic bases** are usually based around nitrogen compounds. In this course, you have studied amines, which are a common organic base. Many of these bases exist in nature and some of the most important are the four nitrogenous DNA bases – adenine, cytosine, guanine and thymine. These are shown in Figure 12.10 on page 350.



**FIGURE 12.10** The four nitrogenous bases found in DNA



**FIGURE 12.11** Amino acids contain an organic acid and an organic base in the same molecule.

Amino acids are a natural molecule that contains both an organic acid and an organic base in the same molecule. Figure 12.11 shows the general structure of an amino acid. There are 20 natural amino acids with only the R group changing between the different acids. Amino acids join together to make **polypeptides** that eventually form proteins.

### Acid–base properties and reactions

Organic acids and bases have the same properties (boiling point and solubility) as already discussed in chapter 9. They also react in the same manner as inorganic acids and bases like sulfuric acid or sodium hydroxide.

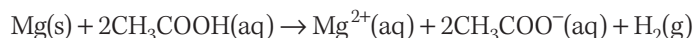
Organic acids are generally weak acids in solution, so only partially ionise when added to water. As a result of this they generally do not have very low pH values when in solution. Each organic acid ionises to a different degree, so for the same concentration different acids will have different pH values. Table 12.3 shows examples of the pH of some organic acids of the same concentration.

**TABLE 12.3** pH of organic acids of a particular concentration

NAME	pH
Oxalic acid	1.31
Pyruvic acid	1.79
Salicylic acid (aspirin)	2.02
Fumaric acid	2.03
Citric acid	2.08
Malic acid	2.21
Methanoic acid	2.38
Ethanoic acid	2.88

As for other acids, organic acids react with active metals, bases and carbonates.

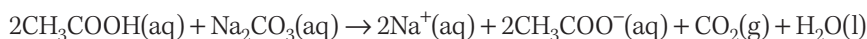
Carboxylic acids react with active metals to produce a salt and hydrogen gas. In the reaction below, ethanoic acid reacts with magnesium to form magnesium ions and ethanoate ions:



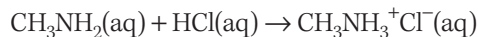
Carboxylic acids also react with a base to produce a salt and water. Ethanoic acid reacts with sodium hydroxide to produce sodium ions and ethanoate ions:



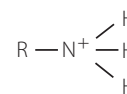
As seen during the ester purification, reaction with a carbonate produces a salt, carbon dioxide and water:



Like wise, organic bases will react with acids to form a salt and water in a Brønsted–Lowry reaction. The reaction below shows the addition of hydrochloric acid to methanamine to form methylammonium chloride:



Reaction with an acid forms a compound called a **protonated amine** (conjugate acid of the amine), shown in Figure 12.12. This compound has substantial differences in properties to the original amine, mostly due to the presence of the charge affecting solubility, boiling point and chemical reactivity.



**FIGURE 12.12**  
A protonated amine forms when an acid is added to an amine.

## INVESTIGATION 12.2

### Properties of organic acids and bases

#### AIM

To investigate some properties of organic acids and bases.

#### MATERIALS

- 0.10 mol L<sup>-1</sup> solutions of ethanoic acid, methanoic acid, citric acid, hydrochloric acid
- 0.10 mol L<sup>-1</sup> sodium carbonate solution
- 0.10 mol L<sup>-1</sup> sodium hydroxide
- 0.10 mol L<sup>-1</sup> solution of 1–2 organic bases (suggestions: diethylamine/diethanolamine bisulfite/diethanolamine)
- Test tubes
- Test-tube rack
- pH probe
- Universal indicator and charts
- Organic waste container

WHAT ARE THE RISKS IN DOING THIS INVESTIGATION?	HOW CAN YOU MANAGE THESE RISKS TO STAY SAFE?
Organic compounds can release toxic vapours.	Keep containers stoppered when not in use. Perform in a well-ventilated area or in a fume cupboard if available.
Acids and bases are corrosive.	Wear personal protective equipment and wash hands after experiment has been completed.



What other risks are associated with your investigation? How can you manage these?

#### METHOD

- Using the equipment provided, conduct tests to distinguish between the acids and bases provided.
- Measure the pH of each of the acids provided and record their values. **Note:** Acids used must be of the same concentration.



- » 3 React all solutions, recording all observations:
- with sodium carbonate solution
  - with sodium hydroxide, adding 2–3 drops of universal indicator.

#### RESULTS

Record your observations/results in a suitably formatted table.

#### DISCUSSION

- Describe the tests you conducted in step 1 of the method. Include any observations made, write equations for any reactions that occurred and explain how your tests distinguished between the acids and bases.
- Explain the different pH values recorded for the different acids measured in step 2.
- Write equations for any reactions that occurred in step 3. Explain why some solutions did not react.

#### CONCLUSION

With reference to the results obtained and its analysis, write a conclusion about the reactions of organic acids and bases.

- Organic acids include carboxylic acids; organic bases include amines.
- Organic acids and bases undergo the same reactions as inorganic acids and bases.
- Organic acids are weak acids that ionise to different degrees, and react with bases, carbonates and active metals.
- Organic bases react with acids; for example, amines react with acids to form a protonated amine.

#### CHECK YOUR UNDERSTANDING

12.3

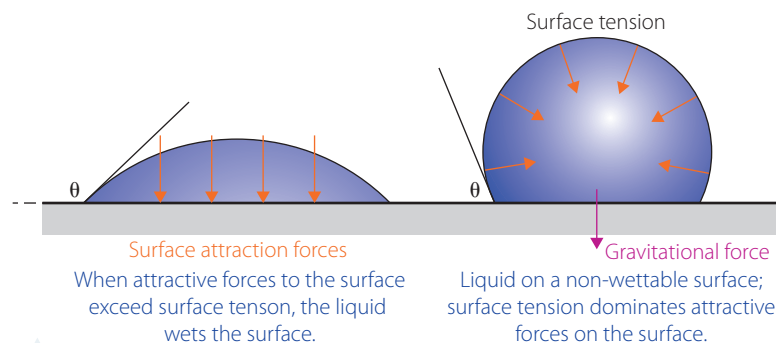
- Identify:
  - two similarities between organic acids and bases and inorganic acids and bases
  - one difference between organic acids and bases and inorganic acids and bases.
- Draw the structure of an amino acid, circling and labelling the acidic and basic functional groups.
- Write equations for the reaction of:
  - propanamide with hydrochloric acid
  - methanoic acid with sodium carbonate
  - ethanoic acid with calcium metal.
- Use Table 2.3 (page 350) to explain why organic acids with the same concentration have different pH values.

## 12.4 Soaps and detergents

Soaps and detergents are generally used as cleaning products because of their ability to remove dirt, oil and stains. This vital property is due to the structure of the soap and detergent molecules. Our knowledge of this structure has enabled us to synthesise more effective cleaning products.

Dissolving soaps or detergents in water lowers the **surface tension** of the water. When present, the **surfactant** breaks the hydrogen bonding between the molecules and the water spreads out onto the surface (i.e. wets the surface) rather than remaining in a droplet.

Figure 12.13 shows the effect of a surfactant on a water droplet. A liquid will wet a surface if there is strong intermolecular attraction between the liquid and the surface. A liquid will bead on the surface if there are stronger cohesive forces (intermolecular bonds) within the liquid than the adhesive forces (attractive forces) between liquid and the surface. The contact angle ( $\theta$ ) is a way of measuring a property called **wettability**.

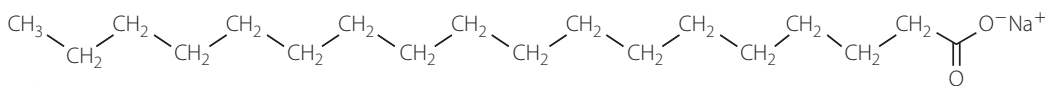


**FIGURE 12.13** A liquid's ability to wet a surface depends on the balance of forces within the liquid and between the liquid and surface.

Another important property of soaps and detergents is the ability to act as an **emulsifier**. Immiscible liquids like oil and water have different polarities so will not mix when added together. An emulsifier like a detergent can cause two immiscible liquids to mix, resulting in an **emulsion**.

## Soap and detergent structure

Soaps are salts of fatty acids. They consist of a long hydrocarbon chain, or tail, with a carboxylate ion ( $\text{COO}^-$ ) at one end – known as the head, as shown in Figure 12.14. A positively charged sodium or potassium ion is bonded to the carboxylate ion, making the soap molecule a sodium or potassium salt.

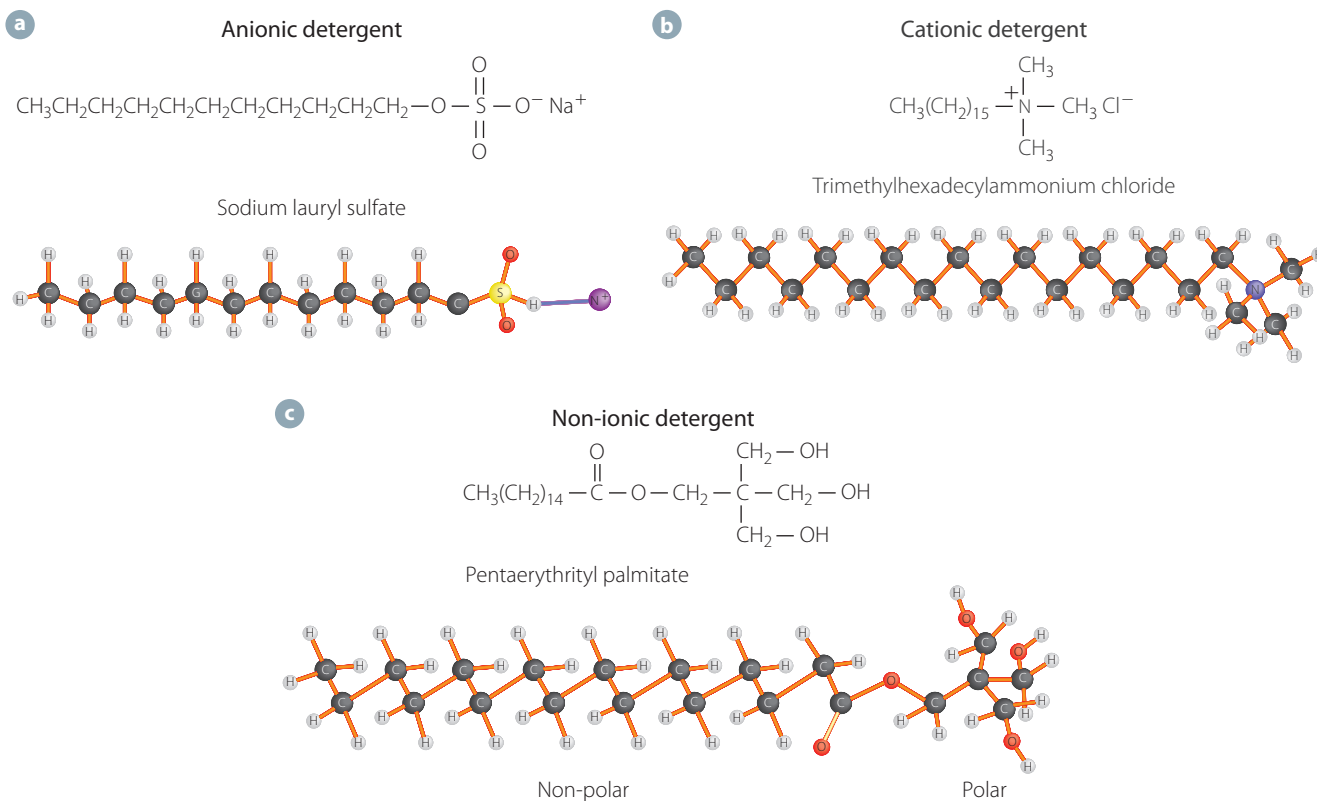


**FIGURE 12.14** The structure of a soap molecule, showing the long hydrocarbon tail and carboxylate ion head

The hydrocarbon tail is very non-polar or **hydrophobic**, and will bond to other non-polar substances through formation of dispersion forces. The ionic head is polar due to the presence of the carboxylate ion. It forms ion-dipole bonds with water, so is **hydrophilic**.

Detergents have a very similar structure to soaps, with a long hydrocarbon tail, but vary in the structure of the polar head. Figure 12.15 (page 354) shows the structure of the three types of synthetic detergents. **Anionic detergents** (Figure 12.15a) have a negatively charged ion, like soaps (for example, a sulfate ion). **Cationic detergents** (Figure 12.15b) have a positively charged ion (for example, a positively charged amine). **Non-ionic detergents** (Figure 12.15c) have no ionic charge, but will usually have a polar functional group like a hydroxyl or carboxylic acid group.





**FIGURE 12.15** Three types of detergents: anionic, cationic and non-ionic

Detergents were synthesised to be used in place of soaps since soaps are ineffective in hard water. **Hard water** contains high levels of calcium and magnesium ions. This effect will be discussed later in this chapter.

Synthetic detergents can be created for specific purposes and used based upon their structure. Table 12.4 shows the properties and uses of different detergent types.

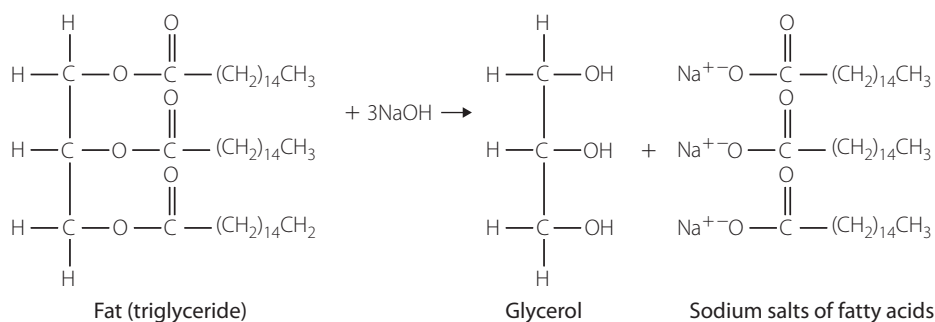
**TABLE 12.4** Properties and uses of detergents

TYPE OF DETERGENT	USES	CHARACTERISTICS
Anionic	<ul style="list-style-type: none"> <li>• Laundry detergents</li> <li>• Dishwashing detergents</li> <li>• Household cleaners</li> </ul>	<ul style="list-style-type: none"> <li>• Create good lather</li> <li>• Have a negative charge</li> <li>• Harsh action (so not suitable for use as personal cleaners)</li> <li>• Cheap</li> </ul>
Cationic	<ul style="list-style-type: none"> <li>• Fabric softeners</li> <li>• Hair conditioners</li> <li>• Disinfectants</li> <li>• Sanitisers (for example, mouthwash)</li> </ul>	<ul style="list-style-type: none"> <li>• Bond very strongly to negatively charged surfaces (reducing static friction and tangling)</li> <li>• Biocidal (kills bacteria)</li> <li>• Expensive</li> </ul>
Non-ionic	<ul style="list-style-type: none"> <li>• Dishwasher detergents</li> <li>• Glass cleaners</li> </ul>	<ul style="list-style-type: none"> <li>• Low lather formation (prevents foam build-up in dishwashers)</li> <li>• Expensive</li> </ul>

## Synthesis of soaps and detergents

Soaps are made through the hydrolysis of fats in a **saponification** reaction. Fats are triglycerides, molecules with three hydrocarbon chains containing 10–20 carbon atoms joined to a propane backbone by three ester bonds. See chapter 10 for more detail on the structure of fats and oils.

When a triglyceride reacts with sodium or potassium hydroxide, the ester bonds break and an alcohol (1,2,3-propantriol or glycerol) and three alkyl carboxylates form, as shown in Figure 12.16.



**FIGURE 12.16** The production of soap from a fat (triglyceride)

This is done by boiling a fat or oil with sodium hydroxide. The soap curdles and forms a solid that can be scraped off and dried to form solid soap. The remaining soap ions in solution are precipitated out by adding a concentrated solution of sodium chloride, a process known as 'salting out'.

## INVESTIGATION 12.3

### Making soap

#### AIM

To make a soap from vegetable oil and compare the properties against a commercially produced soap.

#### MATERIALS

- 6 mL vegetable oil (castor oil, olive oil, canola oil)
- 25 mL of 50% v/v ethanol/water mixture
- 2.5 g solid sodium hydroxide
- 150 mL saturated sodium chloride solution
- Universal indicator and charts or pH probe
- Commercially produced bath soap, liquid soap and detergent
- Deionised water
- 2 × 50 mL beaker
- 150 mL beaker
- 2 × 250 mL beakers
- 10 mL measuring cylinder
- 100 mL measuring cylinder
- 4 test tubes with stoppers
- Test-tube rack
- Hot plate
- Electronic balance
- Stirring rod
- Paper towel
- Spatula
- Gloves





#### WHAT ARE THE RISKS IN DOING THIS INVESTIGATION?

#### HOW CAN YOU MANAGE THESE RISKS TO STAY SAFE?

Sodium hydroxide is corrosive and can cause skin irritation or burns.

Avoid contact with skin by wearing personal protective equipment. Wash hands at end of experiment.

Ethanol is flammable.

Keep clear of naked flame or any hot equipment.

What other risks are associated with your investigation? How can you manage these?

### METHOD

#### PART A: MAKING SOAP

- 1 Set up a water bath by placing a 250 mL beaker containing approximately 75 mL of water on a hotplate set to moderate heat.
- 2 Pour 6 mL vegetable oil into a 150 mL beaker.
- 3 Weigh out 2.5 g of sodium hydroxide in the 50 mL beaker and add 20 mL of the ethanol/water mixture, stirring to dissolve. The ethanol does not take part in the reaction but assists the reaction between the oil and sodium hydroxide.
- 4 Slowly add the sodium hydroxide solution to the oil, stirring continuously during the addition.
- 5 Place the beaker containing the reaction mixture in the water bath and boil gently, stirring frequently. If the mixture is overheated, the mixture may spit out of the beaker. Stir constantly to ensure the mixture does not spit.
- 6 After about 30 minutes of heating and stirring, the oil should be dissolved and the mixture should look thick and creamy.
- 7 Add 25 mL water to the hot solution and stir.
- 8 Pour this mixture into a 250 mL beaker containing 150 mL saturated sodium chloride solution and stir. Allow to cool.
- 9 Remove the soap layer and place into a 50 mL beaker.
- 10 Rinse twice with deionised water to remove excess sodium hydroxide.
- 11 Place the rinsed soap on some paper towel to dry.

#### PART B: TESTING SOAP

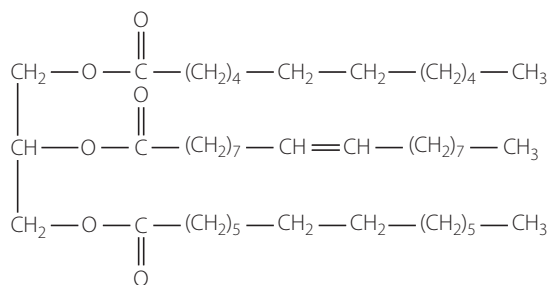
- 1 Place a small amount of your soap in a test tube. In separate test tubes, place the same amount of bath soap, liquid soap and detergent.
- 2 Add 5 mL deionised water to each test tube, stopper and shake. Record your observations, especially the height of the lather formed.
- 3 Determine the pH of each of the solutions.

### RESULTS

Record your observations/results in a suitably formatted table.

### DISCUSSION

- 1 The structure of a molecule of vegetable oil is shown below:



Using this structure, write an equation to show the formation of soap.



- » 2 Using your results, explain whether your soap was better or worse at producing a lather than the commercial soaps. Rank the four soaps and detergents in order of increasing lather production.
- 3 Explain the purpose of:
- the saturated sodium chloride solution
  - the ethanol.
- 4 Compare the pH results you found when you tested each soap/detergent solution.

### CONCLUSION

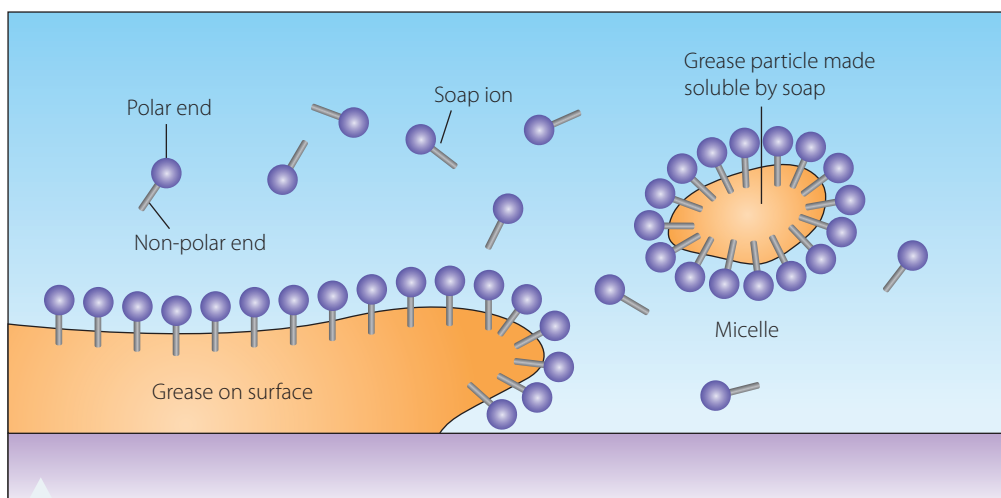
With reference to the results obtained and their analysis, write a conclusion based on the aim of this investigation.

## How do soaps and detergents work?

Soaps and detergents are able to clean because they can bond with both polar and non-polar substances. Soap molecules surround dirt or grease on a surface, with their hydrophobic tails embedded in the dirt or grease due to the formation of dispersion forces.

This leaves the hydrophilic ends on the outside to bond with the water molecules. The ionic head forms very strong ion–dipole bonds with the water molecules.

When the water is agitated, the water molecules pull on the soap molecules through the ion–dipole bonds, which lifts the dirt away from the surface. More soap molecules are able to surround the dirt, eventually completely surrounding it and forming a structure called a **micelle**. Figure 12.17 shows this process.



**FIGURE 12.17** The cleaning action of soap

Each micelle is surrounded by negatively charged heads so micelles repel each other and do not aggregate in the wash water. Due to their small size, they remain suspended in the water and do not resettle on clothes or dishes. When the wash water is drained, the micelles are as well, carrying the grease and dirt away.



Saponification

## INVESTIGATION 12.4

### Action and use of soaps and detergents

#### AIM

To test various properties of soaps and detergents.

#### MATERIALS

- Small amount of bath soap, liquid soap, liquid clothes detergent, liquid dishwashing detergent and soap made in Investigation 12.3 (page 355)
- 0.1 molL<sup>-1</sup> calcium chloride solution
- 5 mL vegetable oil
- Water
- 10 mL measuring cylinder
- Test tubes with stoppers
- Test-tube rack
- Spatula
- Gloves



#### WHAT ARE THE RISKS IN DOING THIS INVESTIGATION?

Some detergents can cause skin irritation with long-term contact or on sensitive skin.

#### HOW CAN YOU MANAGE THESE RISKS TO STAY SAFE?

Wear personal protective equipment and wash hands thoroughly at the end of the experiment.

What other risks are associated with your investigation? How can you manage these?

#### METHOD

##### PART A: HARD WATER TESTING

- Place a small but equal amount of the bath soap, liquid soap, liquid clothes detergent, liquid dishwashing detergent and soap from Investigation 12.3 into separate test tubes.
- Add 5 mL deionised water to each test tube. Stopper and shake. Record observations including height of the lather.
- Repeat steps 1–2 using 5 mL calcium chloride solution instead of deionised water.

##### PART B: USE AS AN EMULSIFIER

- Into two test tubes, place 5 mL vegetable oil and 5 mL water.
- Into one of the test tubes, add five drops of detergent.
- Stopper and shake both test tubes. Record your observations.
- Repeat steps 1–3 for different soaps and detergents.

#### RESULTS

Record your observations/results in a suitably formatted table.

#### DISCUSSION

- Hard water contains high amounts of calcium ions. Explain how part A of the method simulates use of soaps and detergents in hard water.
- Use your results to compare the action of the four soaps and detergents in hard water and tap water.
- Compare the results of part B, and hence, explain the role of detergent as an emulsifier.

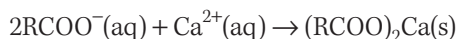
#### CONCLUSION

- Write a conclusion about the action of soaps and detergents in hard water.
- Write a conclusion about the action of detergents as an emulsifier.

## Action in hard water

Hard water contains higher than normal levels of calcium and magnesium ions. Concentrations of greater than 20 ppm of calcium and magnesium ions count as slightly hard water, while very hard water can have concentrations of up to 180 ppm.

Calcium and magnesium ions bond with the carboxylate ions of soap to form a solid precipitate known as **scum**.



Scum settles on clothes and dishes as well as kitchen and bathroom surfaces. It also reduces the number of soap ions available to form micelles. Not only does it produce an unsightly precipitate but also reduces the effectiveness of soap as a cleaning agent.

Detergents also react with calcium and magnesium ions but the resulting molecule does not form scum. The calcium and magnesium salts that form with detergent molecules are soluble in water. Detergents are considered to be superior to soaps when used in hard water for this reason.

While detergents do not form scum, their effectiveness is still reduced in hard water. Other substances, like phosphates, are added to commercial detergents to bind the calcium and magnesium ions so they do not react with the detergent ions. This increases the effectiveness of the detergent since more ions are available to form micelles.

- Soaps are sodium or potassium carboxylate salts with long hydrocarbon chains. Detergents have a similar structure but a different polar head region.
- Soap and detergent molecules have a hydrophobic region (hydrocarbon tail) and a hydrophilic region (polar/ionic head) so can bond with both polar and non-polar molecules.
- Soaps are prepared by the addition of sodium hydroxide to triglycerides. It can be prepared in a laboratory by addition of sodium hydroxide to vegetable oil.
- Soaps and detergents act as emulsifiers, reduce surface tension of water and act as cleaning agents by forming micelles with grease and dirt.
- Soaps form scum in hard water and detergents do not form scum, so detergents are preferred for hard water use.

- 1 Describe how soaps and detergents:
  - a reduce surface tension of a liquid
  - b act as an emulsifier.
- 2 Draw the general structure of a:
  - a triglyceride
  - b fatty acid
  - c soap ion.
- 3 Explain, using a diagram, why a soap or detergent ion can bond with both polar and non-polar substances.
- 4 Describe the similarities and differences between the structure of soaps and detergents.
- 5 Write equations for:
  - a the formation of soap ions (use general formulae)
  - b the addition of soap ions to hard water (use general formulae).
- 6 Describe the reaction conditions necessary to produce a soap from a triglyceride.
- 7 Describe a test that you can do to demonstrate the difference between soap and detergent action in hard water.
- 8 Use a series of diagrams to explain the cleaning action of soaps and detergents.

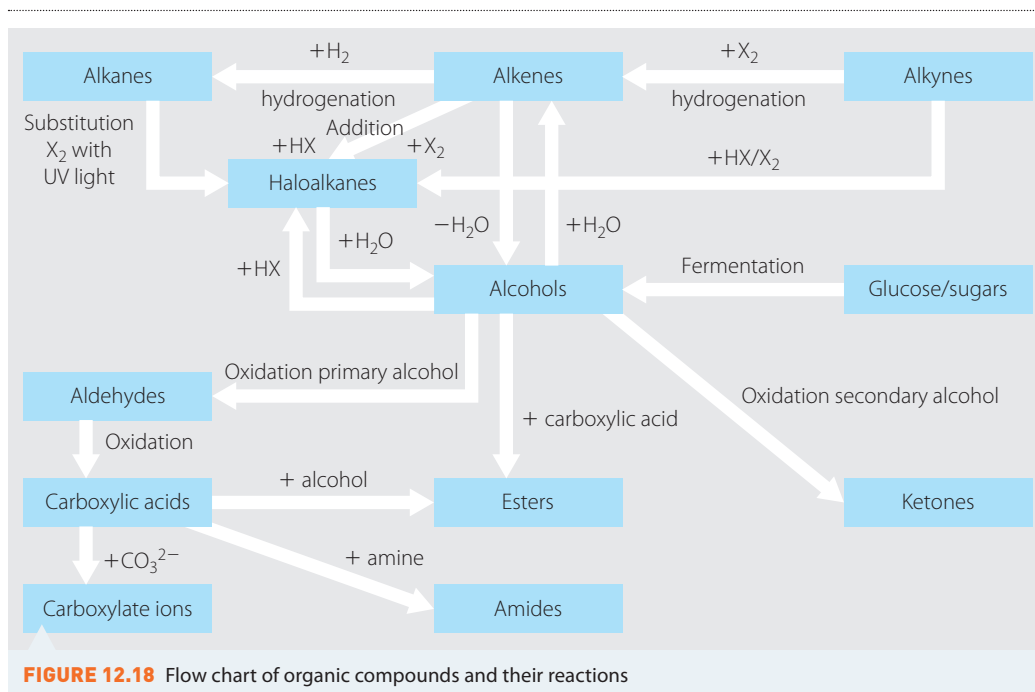
CHECK YOUR  
UNDERSTANDING

12.4

# 12.5

## Summarising organic compounds and reactions

The organic compounds you have learnt about so far and their reactions are summarised in Figure 12.18.



Testing for different organic compounds can be complex so it is important that you not only know the reactions, but the conditions and any other chemicals required.

Some organic tests are distinctive and will positively identify one chemical only. For example, only carboxylic acids (of the compounds you have studied) will give a positive result for reaction with carbonate ions.

Other tests can give a positive result for multiple groups. For example, primary and secondary alcohols, as well as aldehydes, will react with acidified dichromate, giving a colour change from orange to green. Another test that will be positive for different reactions is using the colour change from addition of bromine ( $Br_2$ ) to various hydrocarbons. The orange-brown colour of bromine will disappear if it adds or substitutes onto a hydrocarbon molecule.



## INVESTIGATION 12.5

### Creating a summary of organic reactions and tests

#### AIM

To summarise and present the organic reactions and tests you have learned in chapters 8–12.

#### METHOD

- 1 Use Figure 12.18 as a base to identify all reactions that you have learned in this course. List reagents required, conditions (such as heat or a catalyst) and expected products.
- 2 Design a method of presenting the different reactions. You might consider presenting in a table, an expanded form of Figure 12.18, a poster, an electronic presentation or some other form. Check your idea with your teacher before proceeding.
- 3 Construct your summary.

#### DISCUSSION

- 1 Identify which reactions can be used as distinguishing tests. These are tests that only give a positive result for one class of chemicals.
- 2 Explain why distinguishing tests are important when trying to identify classes of compounds.
- 3 Identify reactions that gives a positive result with more than one class of organic compound.

### Multistep synthesis of organic compounds

Both the summary you have just created and Figure 12.18 can be used to design a method to prepare a particular organic chemical from a specific type of compound.

To do this, you would work backwards from the intended product, identifying which reactions need to occur. This lets you identify the required reagent and any other chemicals or conditions that are necessary.

For example, using Figure 12.18, if you were asked to prepare ethanoic acid from an alkene you would use the following procedure.

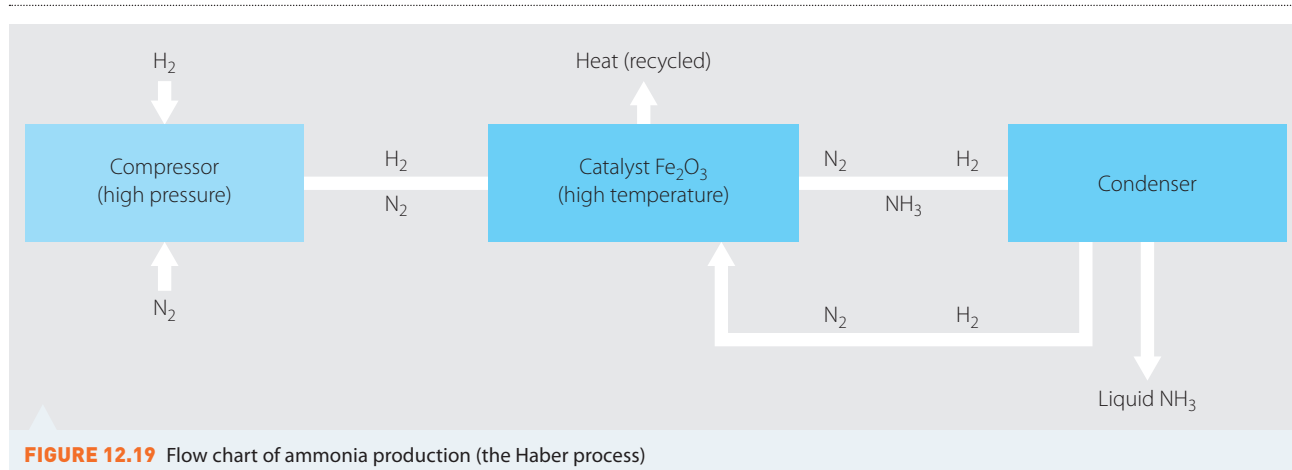
- 1 Start with ethanoic acid and identify that it can be produced by oxidation of a primary alcohol using acidified dichromate ions. To produce ethanoic acid, you must use ethanol.
- 2 To produce ethanol from an alkene you would add water to an alkene to produce the alcohol. To produce ethanoic acid, you must use ethene.

Thus you would write equations for the addition of water to ethene to produce ethanol, then the oxidation of ethanol to ethanoic acid.

## 12.6

# Designing and constructing flow charts for chemical synthesis

While Figure 12.18 (page 360) shows general reactions, the production of a specific chemical can be represented by a more detailed chemical flow chart. A flow chart shows each step in the production of the chemical and how the chemicals move through the chemical plant or process. Figure 12.19 shows a simple flow chart for the production of ammonia ( $\text{NH}_3$ ).



**FIGURE 12.19** Flow chart of ammonia production (the Haber process)

From a flow chart such as this, you should be able to identify the different steps in the process, **raw materials** (found in usable form in nature) used, where energy might be required, where energy might be recycled and where recycling of chemicals can occur.

The chemicals required for this process are nitrogen and hydrogen. Since these are not raw materials, it is highly likely that they would need to be purchased or converted from raw materials. The gases are fed into a compressor, which puts them under pressure, resulting in a faster rate of reaction. The gases are then passed over catalysts to lower the activation energy of the reaction and increase the reaction rate without a need for extra heat. Extra heat is avoided because it lowers the equilibrium yield in this reaction.

At the end of this stage, the flow chart tells you that three chemicals continue into the process – nitrogen, hydrogen and ammonia. The reaction to form ammonia is an equilibrium reaction in which both reactants and products are present after reaction.

The reaction for the formation of ammonia is:



This is an exothermic reaction, so heat is produced. This heat can be recycled to other parts of the plant (for example, to run machinery).

The three gases are then fed into another section where they are cooled. The higher boiling point ammonia condenses to a liquid, and the nitrogen and hydrogen remain as gases and are recycled. The ammonia has hydrogen bonding between molecules, causing the higher boiling point, while the nitrogen and hydrogen have dispersion forces between molecules, causing them to remain as gases.



Constructing a flow chart

## INVESTIGATION 12.6

### Drafting and constructing flow charts

#### INTRODUCTION

The following information describes the process of methanol production.

- The starting materials for this process are natural gas, water and air.
- The natural gas is fed into reactor 1 where it is reacted with steam at approximately 800°C. The following reactions occur:



- In a different part of the plant, air is fed into an air separation unit, which enables the oxygen in the air to be extracted.
- The oxygen from the air separation unit and all the reactants and products from reactor 1 are fed into reactor 2 where the following reaction occurs at 1000°C:



- The carbon monoxide and hydrogen formed are fed into the methanol generator where the following reaction occurs at 350°C:



- The mixture flows into a large distillation mechanism to be purified. A waste product from the distillation is water.

#### AIM

To describe the process of methanol production by constructing a flow chart using the provided information. Flow charts can be produced on paper, or using online flow chart generators, or by creating a multimedia presentation showing each step and how they are linked.

#### METHOD

- 1 Draft a flow chart of the production of methanol by following the steps below.
  - a Identify the structures/processes involved in the production of methanol and put them into order. For example, reactor 1 and reactor 2 are structures, and reactor 1 feeds into reactor 2. Distillation is a process used.
  - b Arrange the structures on the page so that each structure/process is contained within a box. Draw arrows to show how chemicals flow between each structure/process.
  - c Between each structure/process (box) write the formulae of the chemicals that are moving between them. This includes materials fed in, waste products at any stage, and the final products.

#### DISCUSSION

- 1 Identify any raw materials (found in nature in usable form), waste products (no monetary value or dangerous) and by-products (not main product but have monetary value).
- 2 Explain why the step in the air separation unit is necessary.
- 3 Identify places on your flow chart where chemicals can be recycled and what gases would be recycled in the different stages.
- 4 Identify areas where energy is required and released.





Check your understanding

- Flow charts are used to represent the production of a particular chemical.
- Flow charts show major pieces of equipment or processes in the reaction, along with reactants, reaction conditions and energy flow.

## CHECK YOUR UNDERSTANDING

12.5

- 1 Describe an example of a chemical test that:
  - a provides a positive reaction for one type of organic compound only
  - b provides positive reactions for multiple types of organic compounds.
- 2 Describe the general components of a flow chart.
- 3 Explain what is meant by the term 'raw materials'.
- 4 Describe chemical tests to distinguish between the below chemical families (parts **a** and **b**). For each test, give reagents required, specific conditions and write general equations for any reactions that occur.
  - a Primary and tertiary alcohols
  - b Alkenes, carboxylic acids and primary alcohols
- 5 Outline a sequence of steps, including reagents, conditions and equations you could use in a laboratory to produce pentanone from an alkene.
- 6 Construct a flow chart of biodiesel production.
- 7 Outline a method you could use to produce ethyl pentanoate from two different alkenes. Include all reagents and conditions and write equations for any reactions that occur.

# 12 CHAPTER SUMMARY

## IMPORTANT NEW TERMS

After studying this chapter you should know the meaning of the following terms:

anionic detergent (p. 353)

carboxylate ion (p. 346)

cationic detergent (p. 353)

condensation reaction (p. 344)

emulsifier (p. 353)

emulsion (p. 353)

hard water (p. 354)

heating mantle (p. 345)

hydrophilic (p. 353)

hydrophobic (p. 353)

immiscible (p. 345)

micelle (p. 357)

non-ionic detergent (p. 353)

organic acid (p. 349)

organic base (p. 349)

polyester (p. 342)

polypeptide (p. 350)

protonated amine (p. 351)

raw materials (p. 362)

reflux (p. 345)

saponification (p. 354)

scum (p. 359)

separating funnel (p. 345)

surface tension (p. 352)

surfactant (p. 352)

wettability (p. 353)

## AFTER STUDYING THIS CHAPTER YOU SHOULD KNOW:

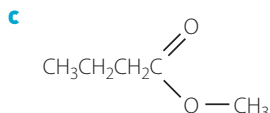
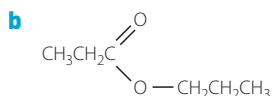
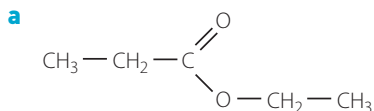
- the definitions for all terms in the important new terms list
- the IUPAC naming conventions for simple, non-branched esters
- the properties of esters, related to their intermolecular bonding
- the steps in the production and purification of an ester
- the products of reactions of organic acids and bases
- the reason for different pH values of organic acids of the same concentration
- the structure and method of synthesis of soaps and detergents
- how soaps and detergents are used to clean, and how they act as an emulsifier
- how hard water affects the action and cleaning ability of soaps and detergents
- the tests used to distinguish between different types of organic compounds
- the components of a chemical production flow chart.

## YOU SHOULD BE ABLE TO:

- name simple esters up to eight carbons in length
- write equations for the formation of an ester from an alcohol and carboxylic acid
- compare the properties of esters to carboxylic acids and alcohols of similar molecular mass
- outline a method for the production and purification of an ester
- write equations for the reactions of organic acids and bases
- outline a method for the production of soap
- outline an investigation to compare the properties of soaps and detergents
- outline methods to distinguish between different organic compounds
- outline methods of preparing organic compounds using multistep processes
- draft and construct flow charts for the production of chemicals.



1 Name the following compounds.



2 Draw structural formulae and give systematic names for all carboxylic acids or esters with molecular formula  $\text{C}_3\text{H}_6\text{O}_2$ .

3 Identify what type of isomerism is displayed in question 2.

4 Explain the difference, in terms of structure and uses between:

- a** soaps and detergents  
**b** anionic, cationic and non-ionic detergents.

5 Describe the cleaning action of soaps.

6 Identify a limitation of soaps and how use of detergents overcomes this limitation. Use an equation in your answer.

7 Compare an ester and a carboxylic acid of similar molecular mass, in terms of:

- a** boiling point  
**b** solubility in water.

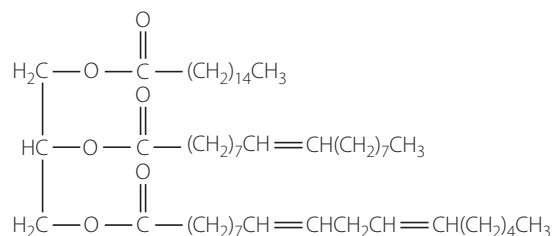
8 Compare the general structure and properties of organic acids and inorganic acids.

9 A solution of oxalic acid has a pH of 1.31. A solution of ethanoic acid with the same concentration has a pH of 2.88. Give reasons for this difference.

10 Write reactions for the addition of the following.

- a** 1-propanol to butanoic acid  
**b** 1-butanol to methanoic acid  
**c** Lithium metal to butanoic acid  
**d** Sodium hydroxide to methanoic acid  
**e** Sodium carbonate to 2-methylpentanoic acid  
**f** Hydrochloric acid to propanamine

11 The diagram below shows the structure of a triglyceride.



- a** Explain whether it is more likely to be a fat or an oil.  
**b** How many different soap ions will form if this triglyceride is used in a saponification reaction? Explain your answer.  
**c** Write an equation for the formation of soap from this triglyceride.

12 Outline a method for the chemical tests that could be used to distinguish between the following pairs of compounds.

- a** 1-butanol and butanoic acid  
**b** 2-propanol and 2-methyl-2-propanol  
**c** Heptane and 2-heptene  
**d** Ethyne and ethyl ethanoate

13 Flow charts represent chemical processes in a different form from text and equations. Identify:

- a** two benefits of using flow charts over other representations  
**b** two limitations of using flow charts over other representations.

14 Choose an appropriate alkane/alkene and describe the steps you would take to prepare:

- a** hexanoic acid  
**b** butanal.

15 Explain the need for the following steps in ester production and purification.

- a** Reflux for 30 minutes  
**b** Washing the reaction mixture with water in a separating funnel  
**c** Addition of sodium carbonate to the reaction mixture

16 Identify two significant risks when preparing and purifying esters. Describe precautions you should take to minimise these risks.

17 Outline a method you could use to produce soap in a laboratory situation. Identify any risks of this experiment and the precautions you should take.

18 Design and draw a flow chart of bioethanol production from grains (with starch as the starting material).



# 13 Polymers

## INQUIRY QUESTION

What are the properties and uses of polymers?

### Students:

model and compare the structure, properties and uses of addition polymers of ethylene and related monomers, for example:

- polyethylen (E) **ICT**
- polyvinyl chloride (PVC) **ICT**
- polystyren (S) **ICT**
- polytetrafluoroethylee (PFE) **ACSCH13** **ICT**

model and compare the structure, properties and uses of condensation polymers, for example:

- nylon
- polyesters.

Chemistry Stage 6 Syllabus © NSW Educational Standards Authority for and on behalf of the Crown in right of the State of New South Wales, 2017







**Polymers** are everywhere in the modern world. They can be natural, such as carbohydrates (for example, cellulose), proteins (for example, silk) and natural rubber, or they can be synthetic.

Synthetic polymers, usually referred to as **plastics**, are fundamental to our lifestyle. They are found in packaging, adhesives, clothes, medical devices and so many other materials that it would be impossible to list them all. These materials have revolutionised sports equipment and been responsible for major advances in electronic technology. The amount of polymers used in the aviation industry has doubled in the last decade because they can be engineered to offer strength and lightness.

From an early age, you have been surrounded by plastic – plastic toys, plastic containers, plastic bags, non-stick coating on pans, and even chewing gum and Lycra in clothes are made from plastic. The development of plastics has only occurred in the last 70 years or so and they have only been used on a massive scale over the last 60 years. At this moment, you are probably using a number of different materials that did not exist even 10 years ago, particularly in electronics technology.



Prior knowledge



**FIGURE 13.1** Some of the many plastics found around the home

At least some of your clothing probably contains synthetic fibres. Your pen is made mainly of plastic, your calculator has a plastic case and so does your mobile phone and computer. All DVDs are made of plastic and so are their containers. Your sports shoes alone probably consist of six or more different kinds of plastic, including the sole, the padding, the upper, the laces and even the lace tips.

Plastics are amazing materials, coming in every shape, size and colour and with every material property you could think of – strong, flexible, elastic, hard, ductile, transparent, slippery, brittle, to name a few. As chemists develop new plastics, the variety of properties and uses expand dramatically.

However, the widespread distribution and use of plastics has not been without cost. There are two main problems that need to be considered as plastic use continues to escalate. One is what to do with plastic articles after they have been finished with and the other is to find a new source of the raw material of plastic manufacture as the current one runs out.

## 13.1 Synthetic polymers

Polymers are giant molecules, often called macromolecules, which form when many smaller molecules, called **monomers**, are joined by covalent bonds. The process of linking monomers together is called polymerisation.

The two most common polymerisation reactions are:

- ▶ addition polymerisation, which involves an addition reaction
- ▶ condensation polymerisation, which involves a condensation reaction.

Polymers may be natural or synthetic. Natural polymers, including silk, wool and hair (made of proteins), starch (made of carbohydrate) and DNA, are manufactured by living organisms. Synthetic polymers, commonly referred to as plastics, are manufactured in laboratories or on larger scales in factories.

It is important at this stage to distinguish between synthetic polymers and plastic. While all plastics are synthetic polymers, not all synthetic polymers are plastics. Plastics are malleable and pliable and capable of being moulded by heat and pressure. Chemists distinguish between polymers that can be melted and reformed and those that cannot by using the terms **thermoplastic** and **thermosetting**.

Thermoplastic polymers soften on heating and so are easily recycled because they can be melted and remoulded. Thermoplastic polymers are used in plastic bags and plastic wrap (polyethylene), garden hoses (polyvinyl chloride) and soft-drink bottles (polyethylene terephthalate), as shown in Figure 13.2. Thermosetting polymers do not become soft or change shape on heating, so are not easily recycled. These polymers are generally stronger, more chemically resistant and more durable than thermoplastic polymers and are used, for example, in insulating foams (polyurethane), worktop surfaces (melamine), some older electrical insulators (Bakelite) and crockery and cutlery, as shown in Figure 13.3. The differences in these types of polymers are due to the structure and bonding within the polymer.

### Starting with ethylene

Ethylene (ethene), which is obtained from crude oil, is the most widely used starting material for making synthetic polymers.

Crude oil is a mixture that is separated into its various fractions by fractional distillation. Generally, more petrol is needed than is supplied from the fractional distillation of crude oil so the longer carbon chain fractions are broken into smaller components by either catalytic cracking or thermal cracking. Catalytic cracking occurs at a temperature of about 500°C, moderate pressures of about 4–20 atmospheres and uses catalysts called zeolites. Thermal cracking does not use a catalyst; hence, the temperature and pressure required are much higher. The temperature for thermal cracking is about 700°C and the pressure required can be as high as 70 atmospheres.

Thermolastics and thermosetting polymers  
More examples of these polymers



**FIGURE 13.2** Plastic drink bottles are made of a thermoplastic polymer so can be easily recycled.



**FIGURE 13.3** Melamine is an example of a thermosetting plastic.



Ethylene and polymers

# INVESTIGATION 13.1



Information and communication technology capability



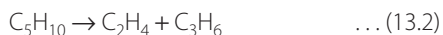
Critical and creative thinking

## Modelling cracking of long chain alkanes

### INTRODUCTION

Alkanes with 15–25 carbon atoms undergo cracking and are broken into two smaller molecules – an alkane and an alkene. The alkene may be further split into smaller alkenes.

For example:



### AIM

To model the cracking of pentadecane ( $\text{C}_{15}\text{H}_{32}$ ).

### MATERIALS

- Molecular model kit
- Digital camera



WHAT ARE THE RISKS IN DOING THIS INVESTIGATION?	HOW CAN YOU MANAGE THESE RISKS TO STAY SAFE?
Minimal risks involved in this investigation	

What other risks are associated with your investigation? How can you manage these?

### METHOD

- 1 Use the molecular model kit to make the pentadecane ( $\text{C}_{15}\text{H}_{32}$ ) molecule.
- 2 Take a photo of this molecule.
- 3 Determine which bonds need to be broken and which bonds need to be formed to produce the products in reaction 13.1.
- 4 Take a photo of the model of the products in equation 13.1.
- 5 Repeat the method from steps 1–4 to model equation 13.2.

### RESULTS

Record results using an appropriate format.

### CONCLUSION

Discuss the advantages and limitations of this method for modelling the cracking process.

- Polymerisation is a chemical reaction in which many small molecules called monomers link together by covalent bonds to form one large molecule called a polymer.

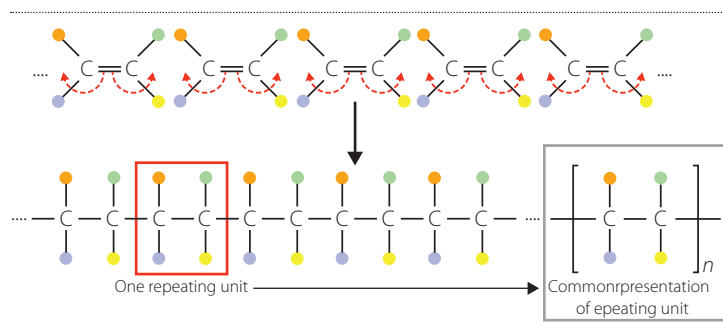
- 1 Explain the relationship between a monomer and a polymer.
- 2 What is the difference between a synthetic polymer and a natural polymer?
- 3 How are thermoplastic polymers different from thermosetting polymers?
- 4 Explain what occurs during a polymerisation reaction and name two types of polymerisation reactions.
- 5 Write an equation for the catalytic cracking of:
  - a butadecane ( $C_{14}H_{30}$ ) into a  $C_8$  alkane and a  $C_6$  alkene
  - b the  $C_6$  alkene into two  $C_3$  alkenes.
- 6 What are the advantages of using a catalyst to produce smaller molecules?

## 13.2 Addition polymers

**Addition polymers** form by adding together monomers without the loss of any atoms. They do this through addition polymerisation, which is a type of addition reaction.

For addition polymerisation to occur, the monomer must have a double bond between two carbon atoms. The breaking of the double bond provides each carbon with an available electron to form bonds between the monomers. The number of monomer units that make up these polymers may range from 100 to more than 100000.

The general process for the formation of addition polymers is shown in Figure 13.4.



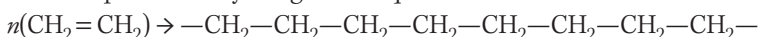
**FIGURE 13.4** A schematic diagram of the formation of an addition polymer from an alkene

To revise addition reactions of alkenes and alkynes, refer to *Chemistry in Focus Year 12* section 10.2, p. 295.

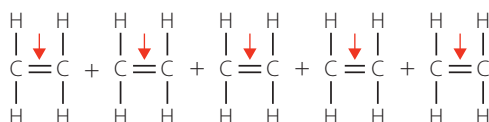
### Polymers from ethylene

One of the most common addition polymerisation reactions occurs in the production of polyethene, which involves the linking of ethene (ethylene) molecules into long chains. Note that while the IUPAC preferred name is polyethene, the common name for the polymer produced is polyethylene. Therefore, the name polyethylene will be used when referring to this polymer.

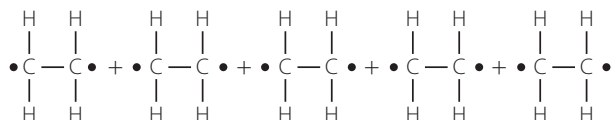
This is represented by the general equation:



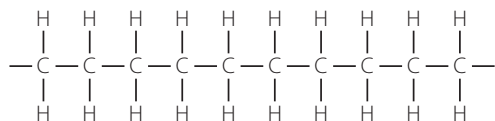
During this addition polymerisation, one of the bonds in each of the  $\text{C}=\text{C}$  double bonds is broken under the influence of a catalyst at high temperature and pressure. This leads to the formation of covalent bonds between C atoms on adjacent monomers (ethylene molecules), as can be seen below.



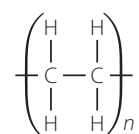
This frees up one electron on each C for further bonding:



New carbon-carbon bonds form between adjacent molecules to give polymer chains:



As can be seen, the polymer is made up of repeating  $\text{CH}_2\text{—CH}_2$  units, so the structure of the polymer is often written in an abbreviated form:



where  $n$  is the number of monomer units in the molecule.

There are two types of polyethylene – low-density polyethylene (LDPE) and high-density polyethylene (HDPE). They are produced by two different processes. Their different properties are a result of differences in their structures.

Low-density polyethylene is produced by a gas phase process using high temperature ( $300^\circ\text{C}$ ), high pressure (1000–3000 atm) and an **ntator** (to start the reaction). This product has significant chain branching due to some of the hydrogen atoms being replaced by an alkyl group. The branches prevent the polymer chains packing closely together so there is a lot of space in the product and weaker dispersion forces between them. This leads to its low density, low melting point and greater flexibility.

The Ziegler–Natta process for the production of HDPE uses lower pressures (only a few atmospheres) and temperatures ( $60^\circ\text{C}$ ) and a catalyst that is a mixture of titanium(III) chloride and trialkylaluminium compound (for example,  $(\text{CH}_3\text{CH}_2)_3\text{Al}$ ). The process forms unbranched polyethylene chains that can pack closely together in an orderly way. Because the chains are packed more closely together, this product has a higher density. There is also stronger bonding because there are stronger dispersion forces between chains, resulting in a higher melting point and less flexibility.



Addiion polymers



## INVESTIGATION 13.2

### Comparing structures of LDPE with HDPE

#### AIM

To compare the structure of LDPE and HDPE.

#### MATERIALS

- Molecular model kit
- Digital camera

#### WHAT ARE THE RISKS IN DOING THIS INVESTIGATION?

Possible risk of slipping on model kit components if they are on the floor

#### HOW CAN YOU MANAGE THESE RISKS TO STAY SAFE?

Keep all components within the containers provided if not being used.



What other risks are associated with your investigation? How can you manage these?

#### METHOD

- 1 Make about 10 molecules of ethylene with the model kits.
- 2 Take a photo of your monomers.
- 3 Work with several other students to determine which bonds need to be broken and which bonds need to be formed to make LDPE.
- 4 Take a photo of the model of your LDPE polymer.
- 5 Repeat the method used in steps 1–4 to make HDPE.

#### RESULTS

Record results using an appropriate format.

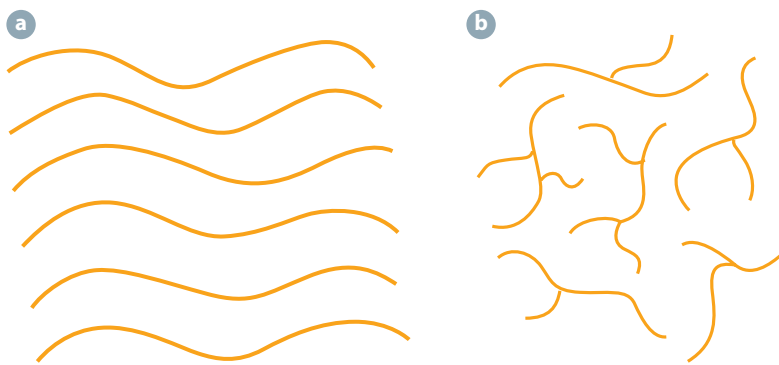
#### ANALYSIS OF RESULTS

Use your results (structures of LDPE and HDPE) to justify whether LDPE or HDPE would have the higher melting point.

#### CONCLUSION

Discuss the advantages and limitations of this method for modelling the structures of LDPE and HDPE.

HDPE has a more ordered structure so is said to be more **crystalline**, while LDPE with its more random structure is **amorphous** (non-crystalline). Figure 13.5 shows the difference between the linear chains of HDPE and the branched chains of LDPE.



**FIGURE 13.5**  
Different arrangements of polymer chains in **a** HDPE and **b** LDPE

## INVESTIGATION 13.3



Information and communication technology capability



Critical and creative thinking

### Investigating crystalline and amorphous packing of polymer chains

#### INTRODUCTION

The arrangement of polymer chains and the strength of interactions between adjacent chains is the reason why some plastics are soft and flexible and others are hard and rigid. If the chains can move easily past each other when the plastic is bent, then it will be flexible, but if the chains are held in place, the plastic will be rigid.

When polymer chains are packed closely together in a regular pattern, they form a crystalline area. The more crystalline areas in the polymer there are, the stronger and less flexible it is. The areas where the chains are randomly arranged, and so further apart, are called amorphous.

Many polymers have both crystalline and amorphous regions. Because polymer chains are so long, any one chain can be involved in both regions along its length.

#### AIM

To use spaghetti to make a model of polymer structure.

#### MATERIALS

- Spaghetti (about 100 g)
- Saucepan or large beaker
- Hot plate
- Strainer
- Water
- Transparent container with a flat base and straight sides
- Heat-proof gloves
- Digital camera



#### WHAT ARE THE RISKS IN DOING THIS INVESTIGATION?

Boiling water can cause serious burns.

#### HOW CAN YOU MANAGE THESE RISKS TO STAY SAFE?

Use heat-proof gloves to handle the container with boiling water.

What other risks are associated with your investigation? How can you manage these?

#### METHOD

- Cook the spaghetti according to the manufacturer's instructions.
- Strain the cooked spaghetti to remove the excess water.
- Pour the strained spaghetti into the straight-sided container and allow it to cool.
- Once the spaghetti is cold, turn it out onto a flat surface, being sure it retains its block shape (Figure 13.6).

#### RESULTS

Draw a diagram or take a photo of the flat bottom of the spaghetti.

#### ANALYSIS OF RESULTS

- Identify crystalline and amorphous regions on your diagram or photo.
- Estimate the percentage of crystallinity (that is, how much of your polymer is crystalline) in your 'polymer' and compare this with other students' results.

#### DISCUSSION

- Compare how easy it is to lift a piece of spaghetti from an amorphous region and a crystalline region. Discuss this in terms of intermolecular forces.
- Discuss whether your polymer would be more or less rigid than those of other students. Justify your reasons.

#### CONCLUSION

Relate the properties of the amorphous and crystalline regions to the properties of LDPE and HDPE.



FIGURE 13.6 An upturned spaghetti cake



## INVESTIGATION 13.4

### Polyethylene

#### INTRODUCTION

Consider the data for low-density and high-density polyethylene in the following table. Use this information to answer the questions.

POLYMER	MELTING POINT (°C)	DENSITY (g mL <sup>-1</sup> )	TENSILE STRENGTH (MPa)	% CRYSTALLINE REGIONS
LDPE	80	0.92	15	40–55
HDPE	135	0.96	29	70–80

#### DISCUSSION

- 1 Will either of the polymers sink in water?
- 2 Why does HDPE have more crystalline regions than LDPE?
- 3 Why is the melting point of LDPE lower than that of HDPE?
- 4 Why is the tensile strength of LDPE lower than that of HDPE?
- 5 Use the information to explain why HDPE is an important material for hospital equipment, while LDPE is used as a plastic food cling wrap.

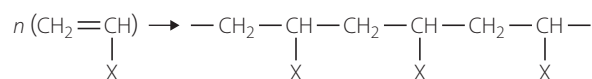
**TABLE 13.1** Differences in structure, properties and uses of LDPE and HDPE

POLYMER	STRUCTURE AND BONDING	PROPERTIES	USE
Low-density polyethylene (LDPE)	Amorphous (disordered) Branched chains Weak bonding due to weaker dispersion forces between chains that are further apart	Soft, flexible, transparent, impermeable to water vapour, unreactive towards acids and bases, absorbs oils and softens, low melting point (80–95°C), low tensile strength	Plastic bags, toys, plastic food wraps, wire and cable insulation, lamination film for paper and card used in juice and milk cartons, hard disk drives
High-density polyethylene (HDPE)	Crystalline (ordered) Linear chains Stronger bonding due to stronger dispersion forces between chains that are closer together	Denser, tougher, more rigid, higher melting point and greater tensile strength than LDPE, opaque, impermeable to water vapour, unreactive towards acids and bases	Detergent bottles, milk and water jugs, fuel tanks for vehicles, bottle caps, food storage containers, 3D printer filament, plastic surgery

#### Other addition polymers

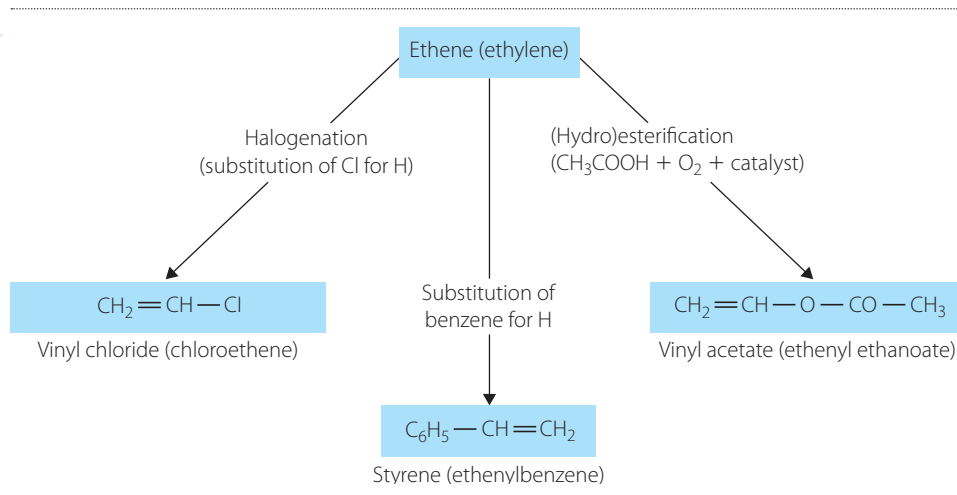
As well as being used directly to produce polyethylene, ethylene is converted into a range of other useful monomers, which are in turn used to produce polymers. This is shown in Figure 13.7 (page 376).

The general reaction for the production of a polymer from an alkene was shown in Figure 13.4 (page 371), where each coloured circle represented a H or a substituent group. This can also be represented by the general equation:



where X may be hydrogen or a substituent group. Substituting the hydrogen with different substituent groups, such as a halogen, benzene or alkyl group, produces polymers with different properties.

**FIGURE 13.7**  
Monomers produced  
from ethylene



As with polyethylene, this can be abbreviated to:  $\left( \begin{array}{c} \text{CH}_2 - \text{CH} \\ | \\ \text{X} \end{array} \right)_n$

## Naming polymers

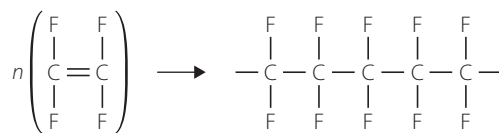
Polymers are named by putting 'poly' in front of the monomer name; for example, polyethylene and polystyrene.

Brackets are used around the name when the monomer name:

- is more than one word; for example, poly(vinyl chloride)
- begins with a number; for example, poly(1-chloroethene).

## Polyfluoroethylene (PTFE)

One or more hydrogen atoms of the alkene may be replaced by a different substituent group. A polymer you might be familiar with under its trade name, Teflon, is an example of this. Polytetrafluoroethylene (PTFE) (systematic name: polytetrafluoroethene) is a polymer formed from the monomer tetrafluoroethylene, which has the formula  $\text{CF}_2=\text{CF}_2$ . All the hydrogen atoms have been replaced by fluorine atoms. The structure of the resulting polymer is shown on the here.



The monomer for PTFE, tetrafluoroethylene (TFE) is not made by substituting the hydrogens in ethylene with fluorine. The manufacturing process involves the synthesis of chloroform, fluorospar and sulfuric acid. Some steps in the manufacturing process require temperatures of about 700°C.

PTFE (Teflon) is most commonly known as the non-stick surface on pans, but it is also used to treat carpets and fabrics to make them stain resistant and has also been used for making artificial body parts. This polymer is also very strong. It is used to make high-grade electrical insulation and pipe thread sealant. The major application, using approximately 50 per cent of PTFE production, is insulation for wiring in aerospace and computer applications.

This polymer has repeating units similar to those of polyethylene, except all the hydrogen atoms have been replaced with fluorine. Its properties are due to the polar carbon-fluorine bonds and dipole-dipole interaction between polymer chains, which make it strong and tough. It also has the third-lowest coefficient of friction of any solid and is resistant to the formation of dispersion forces. It is the only known surface geckos cannot stick to.

## INVESTIGATION 13.5

### How strong is Teflon?



#### INTRODUCTION

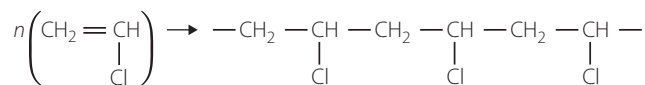
Teflon tape is used by plumbers to make a waterproof seal between threaded iron pipes. You can buy Teflon tape at most hardware stores.

#### METHOD/RESULTS/DISCUSSION

- 1 Cut a 20 cm piece of tape, take a firm grip on each end and stretch it a bit lengthwise. What do you observe?
- 2 Stretch the tape a little width-wise. What do you observe?
- 3 Try to break the tape by stretching it slowly lengthwise. Use as much force as you need.
- 4 Try to break the tape by stretching it width-wise. What do you observe?
- 5 Use what you know about bonding to explain what you observed.

### Poly(vinyl chloride) (PVC)

Poly(vinyl chloride) (systematic name: poly(1-chloroethene)) is made from the monomer vinyl chloride (systematic name: chloroethene). Its structure is:



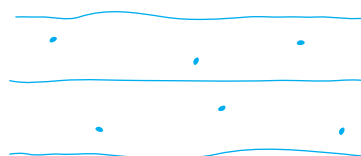
This can be abbreviated to:  $\left( \begin{array}{c} \text{CH}_2 - \text{CH} \\ | \\ \text{Cl} \end{array} \right)_n$

The polymerisation process produces polymer molecules with the chlorine atoms orientated randomly along the chain. The polymer is mainly amorphous (such as LDPE) because of the way the chlorine atoms stick out from the chain and their large size. Although amorphous polymers are usually more flexible than crystalline ones, this is not true for PVC, which tends to be hard and rigid.

Chlorine is a highly electronegative atom so attracts the electrons towards it in the  $\text{---C---Cl---}$  bond, creating a polar bond with the Cl atoms slightly negative and the C atoms slightly positive. The dipole-dipole interactions add to the dispersion forces between polymer chains to make stronger intermolecular forces, holding the polymer chains more strongly together.

**Plasticisers** – small molecules inserted between polymer chains – are sometimes added to hold the polymer chains further apart and weaken intermolecular forces between chains (Figure 13.8). These make the polymer more flexible. The more plasticiser that is added, the more flexible the polymer becomes.

Apart from polyethylene, PVC is the cheapest and most widely used polymer.

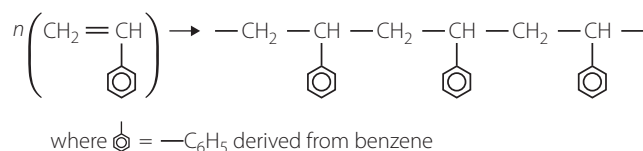


**FIGURE 13.8** Plasticisers act as spacers forcing the polymer chains further apart.

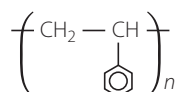
## Polystyrene (PS)

Another common addition polymer is polystyrene. This is made from the monomer styrene (systematic name: ethenylbenzene), which is an alkene to which the phenyl group ( $-\text{C}_6\text{H}_5$ ) (a derivative of benzene ( $\text{C}_6\text{H}_6$ )) has been substituted for one of the hydrogens in ethylene.

The styrene monomer and a segment of the polystyrene polymer are shown below.



This can be abbreviated to:



Styrene is the common (and IUPAC preferred) name for this monomer.

Similar to PVC, the polystyrene produces polymer molecules with the phenyl (benzene) ring orientated randomly along the chain. The polymer is mainly amorphous because of the way the rings stick out from the chain and their large size. The symmetry of the phenyl ring means there are no polar bonds, so the only forces acting to hold the chains together are weak dispersion forces. While the large ring groups prevent the polymer chains packing closely together, they also restrict the ability of the chain to flop around so it tends to be clear, hard and brittle. It is readily softened and moulded on heating but becomes rigid when cooled.

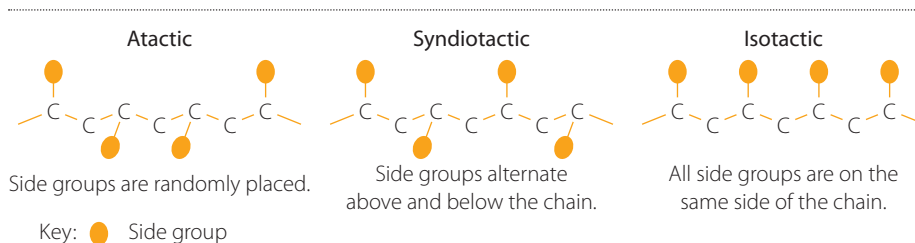
## Polypropylene (PP)

Polypropylene manufacture uses catalysts, including Ziegler–Natta catalysts. There are three variations of the structure of polypropylene depending on the orientation of the  $-\text{CH}_3$  alkyl group relative to the chain. The spatial arrangement of these side groups makes a difference to the properties of the polymer.

The structure of propene and the abbreviated form of the polymer is:



The three possible arrangements are shown in Figure 13.9 where the coloured ovals represent the  $-\text{CH}_3$  group and the hydrogen atoms have been omitted for simplicity.



**FIGURE 13.9** Three possible arrangements of side groups in a linear polymer chain

The regular arrangement of the  $-\text{CH}_3$  groups on the same side of the polymer chain in the **isotactic** arrangement makes it possible for the chains to pack close together and maximise the dispersion forces between them. This means it is quite strong and hard with excellent resistance to stress, cracking and chemical reactions. It is the common form used to manufacture objects such as crates and ropes.



### Poystyrene foam

Watch these videos to see how polystyrene is turned into polystyrene foam.


In the random **atactic** arrangement, the chains cannot lie close together so the forces of attraction are weaker. This results in a softer polymer with a lower melting point. The atactic version formed during the manufacture of the isotactic polymer is considered a waste product and is a soft rubbery polymer, which has limited use mainly as roofing materials and sealants.

**Syndiotactic** polypropylene has only recently been made on a large scale. In this version, the  $-\text{CH}_3$  groups alternate above and below the chain. The regularity means the chains can pack closely, resulting in fairly strong intermolecular forces. However, its attractions are not as strong as the isotactic version, so it is somewhat softer than the isotactic polymer, but also tough and clear. It is used in packaging, and because it is stable to gamma radiation, it has applications in medicine such as medical tubing, bags and pouches.

The isotactic and syndiotactic forms of polypropylene are called **stereoregular polymers**. They are semicrystalline. The chains in the crystalline parts are not stretched out in a zigzag way as in polyethylene, but curl up into regular spirals allowing even stronger bonding.

Table 13.2 summarises information about several common addition polymers.

**TABLE 13.2** Common addition polymers, the monomers they are made from, and some of their uses

POLYMER	NAME AND STRUCTURE OF THE MONOMER	COMMON USES
Polyethylene	Ethene (ethylene) $\text{CH}_2=\text{CH}_2$	LDPE: milk bottles, soft toys, plastic wrap (cling wrap) HDPE: kitchen utensils and containers, more rigid toys, rubbish bins, tougher carry bags
Polypropylene PP	Propene (propylene) $\text{CH}_2=\text{CH}-\text{CH}_3$	Car bumpers, rope and twine, household goods, moulded chairs, carpets
Poly(vinyl chloride) PVC	Vinyl chloride (chloroethene) $\text{CH}_2=\text{CH}-\text{Cl}$	Electrical insulation, garden hoses, drainage and sewerage pipes, household guttering and downpipes
Polytetrafluoroethylene PTFE (Teflon)	Tetrafluoroethene $\text{F}_2\text{C}=\text{CF}_2$	High-grade electrical insulation, non-stick surfaces on cookware, pipe thread sealant
Polystyrene	Styrene (phenylethene) $\text{CH}_2=\text{CH}$ 	Car battery cases, tool handles, modern furniture, disposable drink cups (both foam and clear), foam packing material
Polyacrylonitrile (acrylics)	Acrylonitrile (cyanoethene) $\text{CH}_2=\text{CH}-\text{C}\equiv\text{N}$	As a wool substitute in clothing, blankets, soft furnishings, carpet
Poly(vinyl acetate) PVA	Vinyl acetate (ethenyl ethanoate) $\text{CH}_2=\text{CH}-\text{O}-\text{CO}-\text{CH}_3$	Vinyl coatings on upholstery fabrics, paint, adhesives

## INVESTIGATION 13.6

### Modelling addition polymerisation

#### INTRODUCTION

Structures and properties have been described for a number of addition polymers.

You are to design an investigation to model the structure of at least one addition polymer. Your model needs to be able to demonstrate one or more of the properties of your chosen polymer.

#### AIM

Write an aim for your investigation.



## » MATERIALS

Construct a materials list for your investigation. Make sure you identify quantities of each material that you need.

Complete a risk assessment for your investigation.



WHAT ARE THE RISKS IN DOING THIS INVESTIGATION?	HOW CAN YOU MANAGE THESE RISKS TO STAY SAFE?

## METHOD

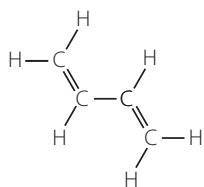
Devise a method for this investigation.

## RESULTS

Record your observations in a suitably formatted table.

## CONCLUSION

Evaluate the effectiveness of your model in modelling the structure and property for your chosen addition polymer.



**FIGURE 13.10**  
Butadiene  
monomer

## Copolymers

To design new polymers with particular properties, more than one monomer might be used. This mixing of monomers can result in significant changes in the property of a polymer. When polymer chains are built from more than one monomer, the new polymer produced is called a **copolymer**.

For example, if a butadiene monomer (Figure 13.10) is copolymerised with styrene, the impact strength of the resultant polymer improves considerably and the product can be used to make battery cases and shoe heels. This modified version of polystyrene is called high-impact polystyrene.

Synthetic rubber is the most widely used copolymer (Figure 13.11). It is a copolymer of styrene and butadiene monomers, which has had further changes made to the polymer chains.

**FIGURE 13.11** Car  
tyres are made from  
a mixture of natural  
rubber and synthetic  
rubber – a styrene–  
butadiene copolymer.



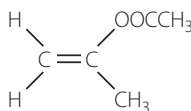


- Addition polymers are synthesised through the process of addition polymerisation, which requires a monomer with a double bond. The structure of the monomer determines the structure and properties of the polymer formed.
- A copolymer is a polymer produced from two or more different monomers. The properties of the copolymer are different from those of polymers composed of only one of the individual monomers.

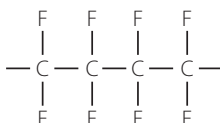
**CHECK YOUR UNDERSTANDING**

13.2

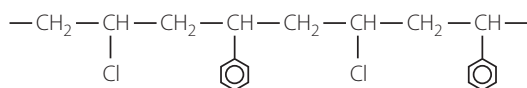
- Identify the structure that is necessary in a monomer for addition polymerisation to occur.
  - Explain the process of addition polymerisation.
- Name the most common addition monomer and polymer.
- What is the difference between an amorphous and a crystalline polymer?
  - How and why do these structural differences affect the properties of a polymer?
- What is a copolymer?
- Perspex is made by addition polymerisation of the monomer below. Draw part of the polymer of Perspex (include at least three monomer units).



- Given the polymer:



- write down the structural formula of the repeating unit
  - write down the structural formula of the monomer.
- Draw the structures of three possible variations of polystyrene.
    - Explain why each of the different structures would have different properties.
  - Draw the copolymer that would form from equimolar amounts of the monomers ethylene and propene.
    - Name and draw the structures of the monomers used to make the following polymer.



- Explain why poly(vinyl chloride) forms a hard, rigid polymer yet polystyrene is hard and brittle when they are both amorphous polymers.
- What is the difference between addition polymerisation and copolymerisation?

## 13.3 Relating properties, uses and structure

When selecting polymers for particular purposes, it is important to match the properties of the polymer with its intended use. The properties depend on the structure of the polymer molecules and the bonding present.

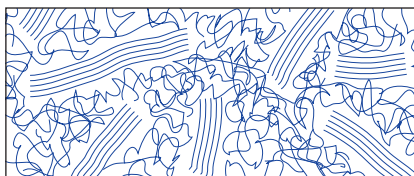
Important structural features are:

- crystallinity
- branching
- chain length
- side groups
- cross-linking
- stability and biodegradability.

## Crystallinity

Molecules of linear polymers, such as polyethylene, can flex and twist. As a result, some molecules will be tangled. The final polymer will have regions that are crystalline and regions that are amorphous (which you saw in the spaghetti cake simulation in Investigation 13.3) (Figure 13.12).

**FIGURE 13.12**  
Crystalline and amorphous regions in a polymer



Key:  Crystalline region  
 Amorphous region



In crystalline regions, the polymer chains are closer together so the intermolecular forces are stronger. This leads to greater rigidity and higher softening and melting points. Other properties that arise when the chains are closer are greater density, opaque appearance and resistance to air, moisture and chemicals. Crystalline regions are non-permeable.

In amorphous regions, the chains are tangled, disordered and have no definite structure. The large gaps between chains means the intermolecular forces are weaker. This leads to more flexibility and lower softening and melting points. Other related properties include transparency, lower density and permeability to water, air and chemicals.

The degree of crystallinity in a polymer determines the properties related to that factor. In commercial polymer production, the percentage of crystalline and amorphous regions can be controlled. Therefore, manufacturers can control many of the properties of the resulting polymer.

## Branching

Chains with little or no branching can pack together more closely than chains with a high degree of branching. Therefore, polymers with low chain branching will tend to be crystalline, so denser, less transparent and less flexible than polymers with a high degree of chain branching, which tend to be more amorphous.

The formation of highly branched structures requires more extreme reaction conditions because covalent bonds have to be broken to insert a branch.

## Chain length

Chain length is controlled by the conditions and proportions of chemicals used in the polymerisation process. In any batch of polymer, there will be chains of different lengths so average molecular weight is considered since this reflects the number of monomer units that combine to make one polymer molecule.

For a given type of polymer, the longer the chain length and the smaller the differences in chain length, the higher the melting point and the harder the polymer.

Chain length affects the flow characteristics of the softened polymer, which in turn affects manufacturing processes. Long chains make the softened polymer more viscous and difficult to extrude, whereas chains that are too short mean the extruded product will sag as it exits the machine. Also, short chains cannot withstand moulding processes that involve blowing the polymer into shape using gases at high temperature.

## Side groups

Another way to change the properties of a polymer is to change the side groups that are attached to the carbon backbone. Putting a bigger side group into a linear chain reduces the flexibility of the polymer, making it stiffer. For example, replacing a hydrogen in polyethylene with a chlorine atom (PVC) or a benzene ring (polystyrene) restricts the ability of the chain to flop around and causes the material to become stiffer and more rigid.

## Cross-linking

The rigidity and hardness of a polymer can be increased by **cross-linking**. In this process, linear chains are linked together to form a more rigid two- or three-dimensional structure. These cross-links usually form strong covalent or ionic bonds between the polymer chains. The greater the amount of cross-linking, the more strongly the polymer chains are bonded and the more rigid the polymer. Figure 13.13 shows an example of cross-linking.

For example, if natural rubber is heated with some sulfur, S—S bonds form between adjacent chains. This makes the material harder and more elastic. This process is called **vulcanisation**.



**FIGURE 13.13** Cross-linking joins chains to each other.

## INVESTIGATION 13.7

### Making a cross-linked polymer

#### INTRODUCTION

PVA glue is made of long chains of poly(vinyl alcohol), which slide past each other fairly easily, allowing the glue to be poured from the bottle. When borax is mixed with the PVA glue, tetrahydroxyborate ions ( $\text{B}(\text{OH})_4^-$ ) form bonds between the polymer molecules of the PVA. The resultant 'slime' is an example of a cross-linked polymer.

#### AIM

To make slime and test its properties.

#### MATERIALS

- 50 mL of poly(vinyl alcohol)
- 10–15 mL of 4% solution of borax (4 g sodium borate (borax) in 96 mL water)
- Distilled water
- 10 mL measuring cylinder
- 50 mL measuring cylinder
- Disposable plastic cup
- Wooden paddle-pop stick
- Newspaper
- Permanent marker
- Water based marker
- Electronic balance
- Straw
- Safety glasses

#### WHAT ARE THE RISKS IN DOING THIS INVESTIGATION?

Borax and PVA will burn eyes.

#### HOW CAN YOU MANAGE THESE RISKS TO STAY SAFE?

Wear a laboratory coat and safety glasses and wash your hands at the end of the experiment. Keep your hands away from your eyes while using the chemicals.



Critical and creative thinking



RISK ASSESSMENT

What other risks are associated with your investigation? How can you manage these?

## METHOD

- 1 Cover your work area with a few layers of newspaper.
- 2 Place 50 mL of PVA glue in a plastic cup and add 50 mL of water. Mix thoroughly.
- 3 Slowly add the borax solution, approximately 5 mL at a time, stirring thoroughly with a wooden paddle-pop stick upon each addition. Be careful not to add too much borax or the slime will become too stiff.
- 4 Remove the slime with the wooden stick and work it with your hands until it is no longer sticky.
- 5 Testing properties:
  - a Take some of the slime in one hand and stretch it slowly. Repeat the stretching exercise rapidly. Does it break apart easier when pulled quickly or slowly?
  - b Place the slime in a ball on the table and poke it quickly with your finger. Poke it again slowly. What happens?
  - c Form the slime into a ball and see if it bounces.
  - d Place a ball of slime on the table and observe it for a few minutes. Does it flow into a puddle or maintain its shape? Does this demonstrate that the slime is a liquid or a solid?
  - e Press the slime down on a piece of newspaper. Is the image transferred to the slime?
  - f Write on a piece of paper with a permanent marker and then with a water-based marker. Press the slime down on the writing. Is the image transferred to the slime?
  - g Try to make slime bubbles by wrapping the slime around the end of a straw and blowing gently. An airtight seal must be made between the straw and the slime.
  - h Place a small amount of slime on a paper towel and set it aside to dry until the following lesson. Note any differences in its appearance and properties.

## RESULTS

Record your observations and results of the property tests.

## ANALYSIS OF RESULTS

Describe how cross-linking has changed the properties of the PVA.

## DISCUSSION

- 1
  - a Write the formula for the monomer of PVA.
  - b Draw a structural diagram of a section of a PVA polymer (include at least four repeating units).
- 2 Draw a diagram to show how the borax forms cross-links between the polymer chains. Use information at the weblink to help you draw your diagram.
- 3 How does water affect the elasticity of the polymer?

## Stability and biodegradability

Most of the bonds in polymers are strong covalent C—C and C—H bonds, so the polymers are fairly stable. This means that most synthetic polymers, unlike natural polymers, are not biodegradable.

However, PVC has C—Cl bonds, which are weaker than C—H bonds, and are broken by ultraviolet light. The polymer becomes brittle and cracked if it has been in sunlight for some time. Special additives, called stabilisers, are added to the polymer to protect it from degradation.

To increase the biodegradability of synthetic polymers, chemists have copolymerised them with natural polymer segments, such as those in starch. This causes the polymer chain to break down into many smaller segments.

## INVESTIGATION 13.8



### Identifying plastics by their density

#### INTRODUCTION

Plastics are synthetic materials with a wide range of properties. One property that can be used to help identify plastics is their density.

You are to design an experiment to identify unknown samples and also to separate and identify the pieces in the mixture.

#### AIM

Write an aim for your investigation.

#### MATERIALS

Construct a materials list for your investigation. Make sure you identify quantities of each material that you need. The following information will help you.

The densities ( $\text{g mL}^{-1}$ ) of common plastics are:

- HDPE 0.95–0.97
- LDPE 0.917–0.940
- PETE 1.38–1.39
- PP 0.90–0.91
- PS (in solid form) 1.04–1.05
- PS (in foam form) variable but always less than 1
- PVC (rigid) 1.30–1.58
- PVC (flexible) 1.16–1.35.

The densities of nine different solutions are found in the following table.

LIQUID	DENSITY ( $\text{g mL}^{-1}$ )
Methanol	0.79
52% ethanol/water mixture	0.911
38% ethanol/water mixture	0.9408
24% ethanol/water mixture	0.9549
Water	1.00
10% solution of NaCl	1.08
Saturated solution of $\text{MgCl}_2$	1.34
40% $\text{CaCl}_2$ solution	1.398
Saturated solution of $\text{ZnCl}_2$	2.01

Complete the risk assessment table for your investigation. Identify specific risks involved in the investigation and ways that you will manage the risks to avoid injuries or damage to equipment. Check the relevant SDS. >>



WHAT ARE THE RISKS IN DOING THIS INVESTIGATION?	HOW CAN YOU MANAGE THESE RISKS TO STAY SAFE?
Methanol and ethanol are highly flammable.	Ensure no flame sources are present near either of these chemicals. Methanol is for teacher use only. It must be used in a fume cupboard.
Zinc chloride is a hazardous material that can cause skin and eye irritation.	Wear gloves and lab coat when handling this material. Do not dispose of zinc chloride down the sink: collect as a waste as per your teacher's instructions.

#### METHOD

- 1 Consider how you will verify the densities of known samples before testing unknown samples.
- 2 Take care that no air bubbles adhere to the samples and shake the tube to check that samples are actually floating.

#### RESULTS

Record your data in a carefully formatted table.

#### ANALYSIS OF RESULTS

Identify the unknown samples, giving reasons for your decisions.

#### CONCLUSION

- 1 Decide which polymer would be best used for each of the following and why.
  - a As a replacement for the lead sinkers used in fishing
  - b To make a toy boat
- 2 Were any plastics difficult to distinguish? What other properties could be used to distinguish these plastics?

#### CHECK YOUR UNDERSTANDING

13.3

- 1 Explain how the percentage of crystalline regions and amorphous regions in a polymer affects its properties.
- 2 What is cross-linking and how does it change the properties of a polymer?
- 3 Explain the relationship between crystallinity and branching.
- 4 Suggest explanations why:
  - a polymers with larger side groups are stiffer
  - b polymers with longer chains form more viscous liquids.
- 5 Suggest why cross-linked polymers are not recycled.
- 6 List four properties that would make a polymer suitable for use as a:
  - a disposable juice bottle
  - b bag in which a roast can be cooked in the oven
  - c transparent cover for outdoor light bulbs
  - d tubes for an intravenous drip in a hospital
  - e plastic raincoat.



Critical and creative thinking



## 13.4 Condensation polymers

Addition polymerisation requires the monomer to have a double bond. However, if organic molecules have a functional group at each end, a functional group can undergo a condensation reaction with a functional group on another molecule to form a **condensation polymer**.

Functional groups such as  $\text{—NH}_2$ ,  $\text{—OH}$ ,  $\text{—COOH}$  and  $\text{—COCl}$  are suitable for condensation polymerisation.

Polyesters and polyamides (nylons) are examples of synthetic condensation polymers, whereas polysaccharides (cellulose and starch) and proteins are examples of natural condensation polymers.

### Polyesters

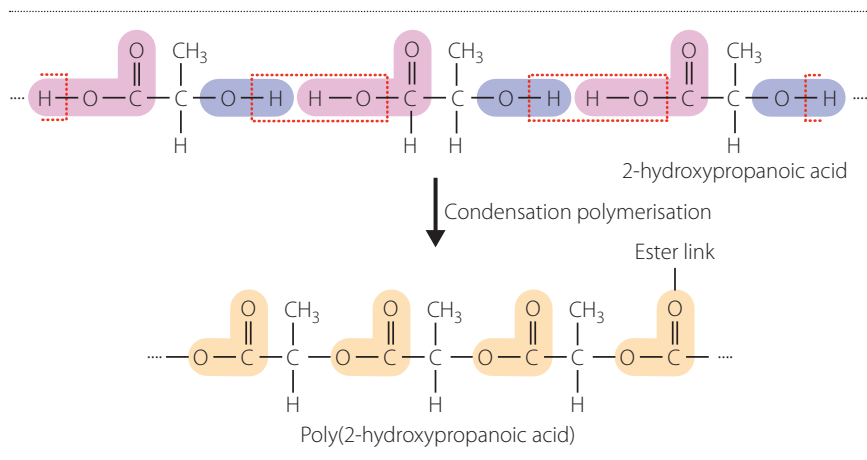
**Polyesters** are condensation polymers in which the monomers are joined by an ester link. Recall from section 12.1 that an ester and water are formed when a carboxylic acid reacts with an alcohol.

To form a polyester, the monomer molecules need to join at each end, which means they need to have either a carboxylic acid or an alcohol functional group at each end.

Polyesters can be produced from:

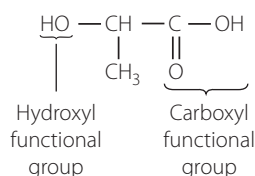
- ▶ a single monomer that has a hydroxyl ( $\text{—OH}$ ) functional group at one end and a carboxyl ( $\text{—COOH}$ ) functional group at the other
- ▶ two different monomers – one monomer with hydroxyl groups at each end (a diol) and one monomer with carboxyl functional groups at each end (a dicarboxylic acid).

The general production of a polyester from a single monomer is shown in Figure 13.14. The monomers must be aligned so the hydroxyl and carboxyl groups are next to each other.



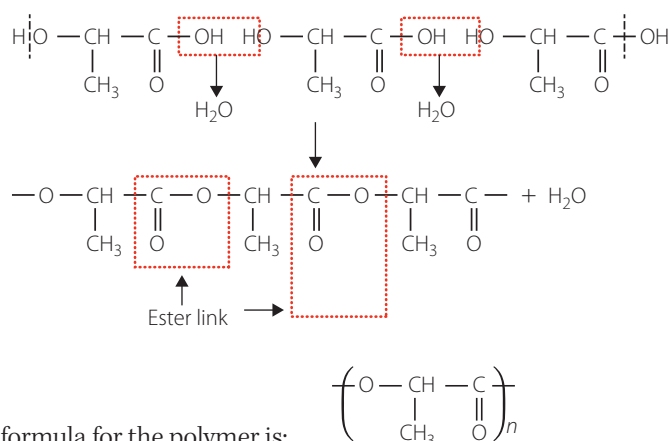
**FIGURE 13.14**  
The formation of a polyester from a single monomer (2-hydroxypropanoic acid)

An example of a polyester is poly(lactic acid), which is used to make biodegradable surgical sutures. Lactic acid (2-hydroxypropanoic acid) has a hydroxyl ( $\text{—OH}$ ) functional group at one end and a carboxyl ( $\text{—COOH}$ ) functional group at the other. The structure is:



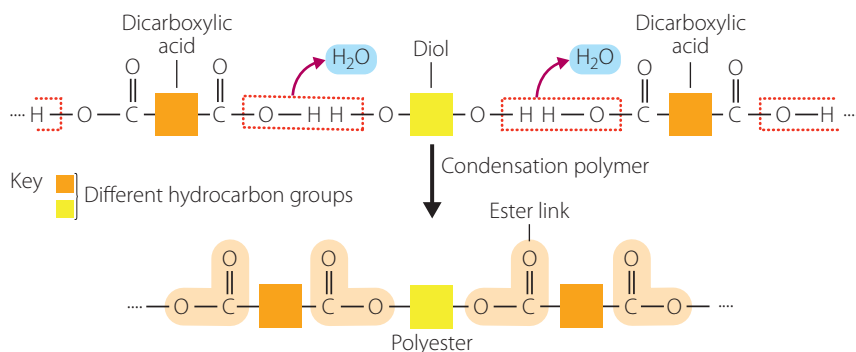
To revise ester formation, refer to section 12.1, p. 342.

The molecules are able to polymerise through an esterification reaction between the carboxyl group of one molecule and the hydroxyl group of another, as shown below.



The general formula for the polymer is:

The production of a polyester from two different monomers (a diol and a dicarboxylic acid) is shown in Figure 13.15. The monomers must be aligned so a hydroxyl group is next to a carboxyl group. Since this polymer is made from more than one monomer, it is classified as a copolymer.



**FIGURE 13.15** The formation of a polyester from a diol monomer and a dicarboxylic acid monomer

It might seem strange that plastic soft-drink bottles and T-shirts are made out of the same thing – but they are. They are both made out of the polymer polyethylene terephthalate (or PET). When this polymer is made into fibres for textiles, it is generally called polyester.

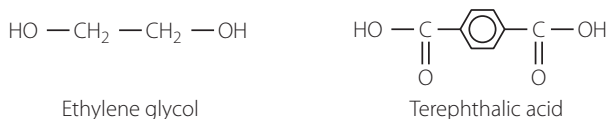
Although the term ‘polyester’ is commonly used when referring to PET fibres, it is not the only type of polyester polymer.

PET is a thermoplastic, which means it can be repeatedly melted and reshaped. When heated, molten PET can be pressed into moulds to make bottles or furniture, or it can be spun – squeezed through tiny holes to form fibres that can be woven into fabric for use in carpets, clothing or quilts. In the fibre form where it is used to make clothes, it is commonly known by the trade names Terylene and Dacron.

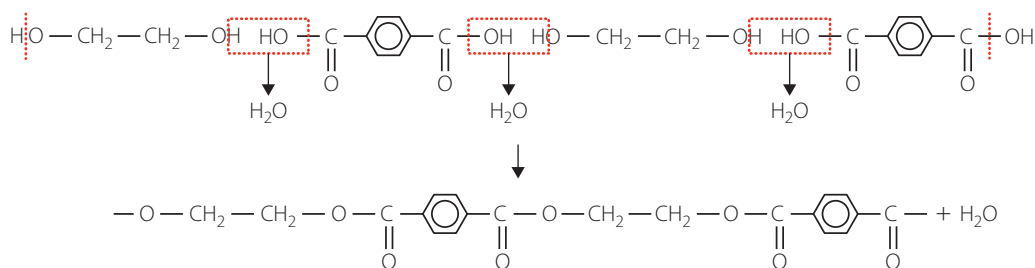
When the product reaches the end of its useful life, PET can be recycled. It is a recycling success story. This polymer has the plastics identification code number 1 and is used for making a huge variety of recycled products, including clothing, carpet, luggage, bottles, tote bags and food and beverage containers.

Five two-litre bottles can be transformed into one T-shirt or the fibrefill insulation for one ski jacket. One square metre of polyester carpet can be made from 36 bottles.

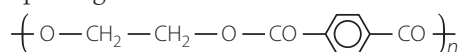
The two monomers used to make PET are ethylene glycol (ethane-1,2-diol) and terephthalic acid (benzene-1,4-dicarboxylic acid). Their structures are:



The two monomers esterify, as shown below.



The abbreviated form of the repeating unit is:



One disadvantage of polyester is that it is easily damaged by acids and alkalis. If a dilute alkali, such as NaOH, is spilt on a fabric made from polyester, the ester linkages are broken. The original alcohol (ethane-1,2-diol) is formed together with the sodium salt of the carboxylic acid, the fibres of the fabric are destroyed and a hole forms in the fabric.

### Polyesters

Find out more about polyesters and how they are manufactured.

## Polyamides

Polyamides are condensation polymers in which the repeating units are held together by **amide links** ( $-\text{CO}-\text{NH}-$ ). This link is also found in proteins where it is called a peptide link.

One of the most important classes of natural polyamides is proteins. The most commonly known synthetic polyamide is nylon. Nylon duplicates some of the properties of natural polyamides and has a wide variety of uses, including fibres to make fabrics, machine components and domestic appliances.

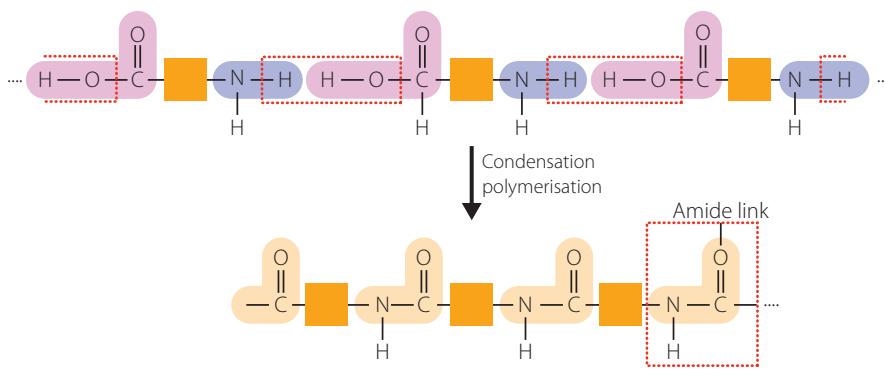
There are various types of nylon depending on the monomers used in its preparation. The first nylon to be produced was nylon-6,6; the simplest is nylon-6. These two nylons account for about 80 per cent of all nylon manufacture, of which 25 per cent is used for fibre applications.

As with polyesters, the monomer molecules must join at each end, which means they need to have either a carboxylic acid or amine functional group at each end.

They can be produced from:

- ▶ a single monomer that has an amine ( $-\text{NH}_2$ ) functional group at one end and a carboxyl ( $-\text{COOH}$ ) functional group at the other
- ▶ two different monomers – one monomer with amine functional groups at each end (a diamine) and one monomer with carboxyl functional groups at each end (a dicarboxylic acid).

The general production of a polyamide from a single monomer is shown in Figure 13.16. The monomers must be aligned so the amine and carboxyl groups are next to each other.

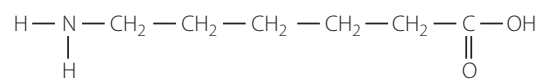


**FIGURE 13.16**

The formation of a polyamide from a single monomer

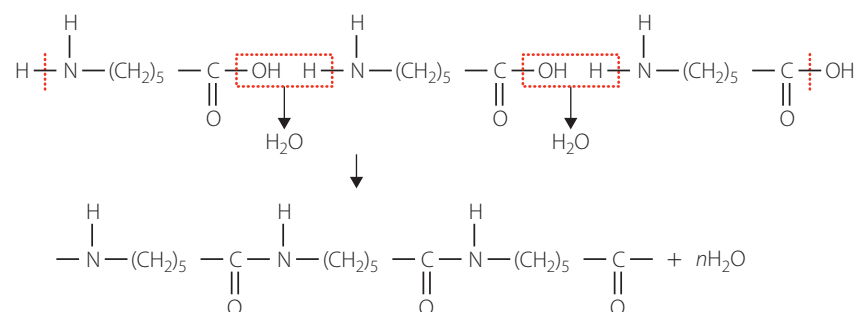
To revise amines and amides, refer to section 9.5, p. 280.

For example, nylon-6 is made from 6-aminohexanoic acid, which has the structure:

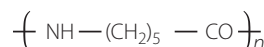


This structure can be abbreviated to  $\text{H}_2\text{N}-(\text{CH}_2)_5-\text{COOH}$ .

The molecules polymerise through a condensation reaction between the carboxyl group on one molecule and the amine group on another:

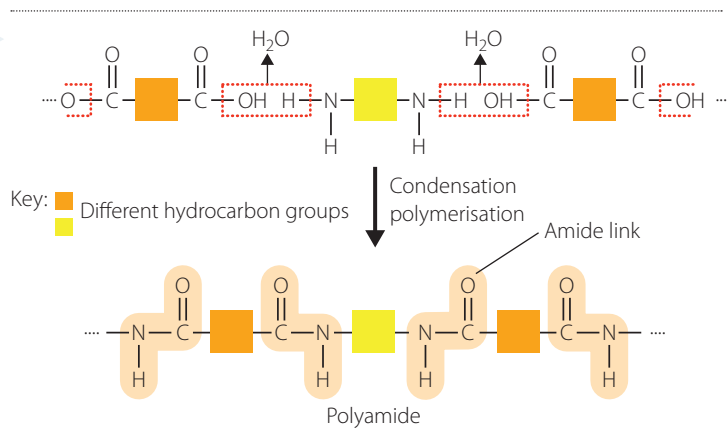


The general structure of this polyamide is:



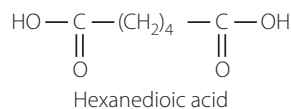
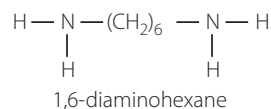
The production of a polyamide from two different monomers (a diamine and a dicarboxylic acid) is shown in Figure 13.17. The monomers must be aligned so that an amine group is next to a carboxyl group. Because this polymer is made of more than one monomer it is classified as a copolymer.

**FIGURE 13.17**  
The formation of a polyamide from different monomers

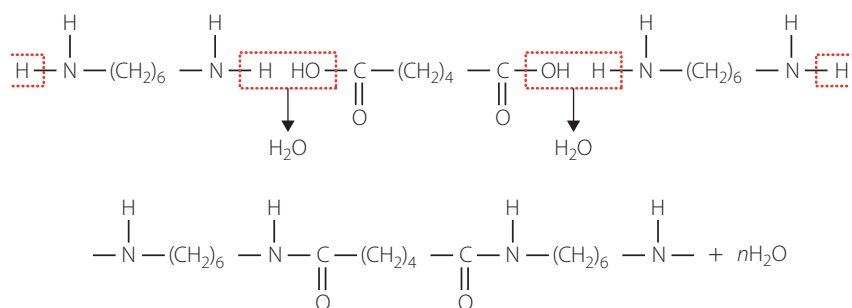


Condensation  
polymers

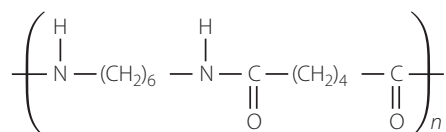
Nylon-6,6 is made from monomers that each have six carbon atoms. The two monomers are 1,6-diaminohexane (also called hexamethylene diamine) and hexanedioic acid (also called adipic acid). The structures of each of these monomers is:



The two monomers react to produce the polyamide:



Its structure can be abbreviated to:



## Naming nylons

The naming of nylons reflects the number of carbon atoms in the monomers used to make them. Nylons are named by giving the number(s) of carbon atoms in the monomer(s) as a suffix. If there are two monomers, the number for the diamine comes first.

Nylon-6 is made from one monomer containing six carbon atoms with an amino group at one end and a carboxyl group at the other.

Different nylons have different properties. The longer the chains of  $-\text{CH}_2-$  groups, the lower the nylon's melting temperature and the less it absorbs water.

Nylon-6,6 is made from two different monomers, making it a copolymer. It is made from a diamine monomer containing six carbon atoms and a dicarboxylic acid containing six carbon atoms.



### The nylon 'rope' trick

Here are the instructions for making nylon in the school laboratory.



### Invention of nylon

Watch this video about how nylon was invented.



### Manufacture of nylon

Visit this website for information about nylons.

## INVESTIGATION 13.9

### Modelling condensation polymerisation

#### INTRODUCTION

Structures and properties have been described for a number of condensation polymers.

You are to design an investigation to model the structure of at least one of the condensation polymers. Your model needs to be able to demonstrate one or more of the properties of your chosen polymer.

#### AIM

Write an aim for your investigation.





### MATERIALS

Construct a materials list for your investigation. Make sure you identify quantities of each material that you need.

Complete a risk assessment for your investigation.



WHAT ARE THE RISKS IN DOING THIS INVESTIGATION?

HOW CAN YOU MANAGE THESE RISKS TO STAY SAFE?

### METHOD

Devise a method for your investigation.

### RESULTS

Record your observations in a carefully formatted table.

### CONCLUSION

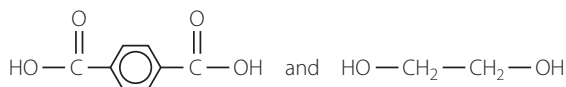
Evaluate the effectiveness of your model in modelling the structure and property for your chosen condensation polymer.

- Condensation polymers are formed when two monomer molecules join together to eliminate a small molecule (often water). The process is called condensation polymerisation.
- Polyesters are condensation polymers in which the monomers are joined by an ester link.
- Polyamides are condensation polymers in which the repeating units are held together by amide links.
- The naming of nylons reflects the number of carbon atoms in the monomers used to make them.

### CHECK YOUR UNDERSTANDING

13.4

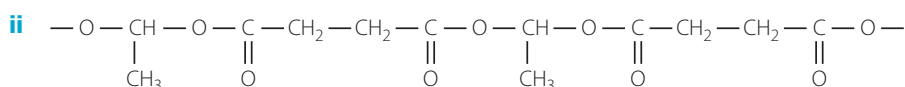
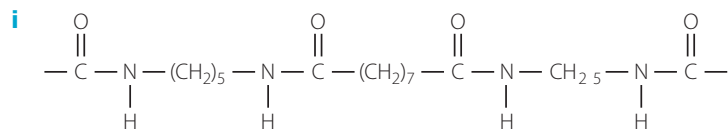
- 1 Name two types of condensation polymers.
- 2 Explain how condensation polymerisation is different from addition polymerisation.
- 3 Draw the structure of an:
  - a ester link
  - b amide link.
- 4 a Draw a segment of the structure of each of the following polymers.
  - i Poly(glycolic acid) formed from the monomer  $\text{HO}-\text{CH}_2-\text{COOH}$
  - ii Nylon-5 formed from the monomer  $\text{H}_2\text{N}-\text{CH}_2-\text{CH}_2-\text{CH}_2-\text{CH}_2-\text{COOH}$
 b Draw the abbreviated structures for the polymers in parts i and ii.
- 5 Draw three repeat segments showing the structure of the polymers formed when the following react.





- 6 For each of the polymers in question 5:
- identify the type of polymer
  - circle and name the type of link present
  - name the functional groups present in the monomers.

7 For each of the polymers i and ii below:



- identify the type of polymer
  - draw the structure of the monomers
  - identify the organic group to which the monomer belongs
  - name the monomers.
- 8 For each of the polymers shown in question 7 predict the type of bonding that would occur between polymer chains and explain why.

## 13.5 Natural polymers

You have seen some examples of synthetic polymers. You have also seen how condensation polymers join monomers to produce a polymer and release a small molecule, usually water at each linkage. There are also condensation polymers that occur in nature. They are very important for the survival of living organisms.

### Proteins – a natural polyamide

Proteins are an essential part of every living cell. They are the major structural component of hair, skin and muscle, so structural and mechanical proteins are tough, insoluble in water and have a stringy appearance. Proteins are also essential to the chemical processes that take place in our bodies, including transporting oxygen (haemoglobin), nutrients and minerals through the bloodstream. Many hormones, such as insulin, are proteins and most enzymes (biological catalysts) and antibodies are proteins. Examples of a number of proteins can be seen in Figure 13.18.

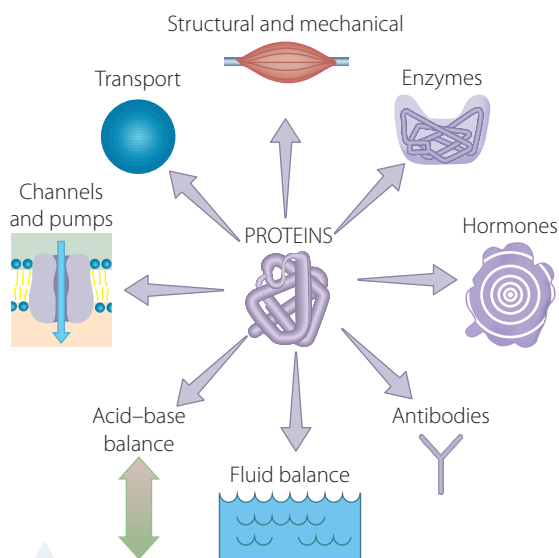


FIGURE 13.18 Protein functions

Proteins are large polymers (polyamides or polypeptides) formed when many smaller monomer molecules link together in a condensation polymerisation reaction. The monomer building blocks of proteins are amino acids. Although only 20 different amino acids are found in proteins, there are hundreds of thousands of different proteins due to the many different combinations of amino acids.

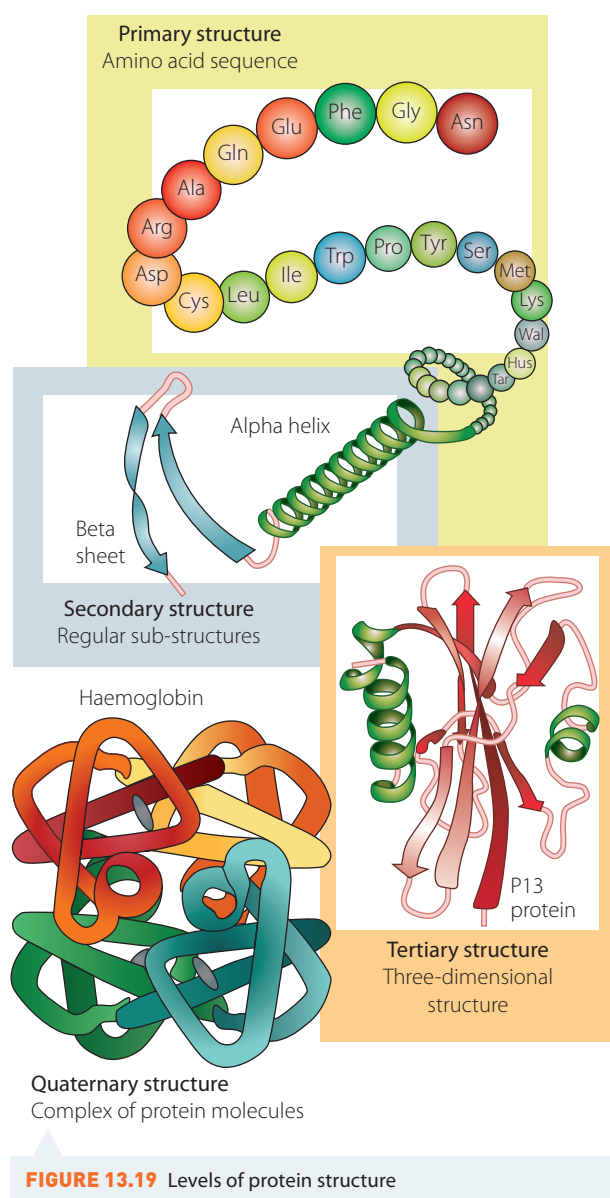
All protein molecules are long chain-like molecules with different side groups strung out along a repeating backbone of mainly carbon atoms. The long protein chains are normally folded into complex and highly specific shapes, allowing them to perform very specialised functions within living organisms.

The most important features of a protein that enable it to perform its specific biological function include the:

- ▶ nature and sequence of amino acids that make up the polymer chain and give the primary structure
- ▶ way the polymer chain is arranged within segments to give it its secondary structure
- ▶ way the secondary structure is arranged to give the whole molecule its tertiary, and sometimes quaternary, structure.

These structures are shown in Figure 13.19.

The sequence of amino acids determines the primary structure of a protein chain. The way the protein folds to produce the secondary structure depends on this sequence.



**FIGURE 13.19** Levels of protein structure

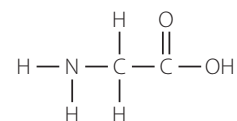
Amino acids contain the amine ( $-\text{NH}_2$ ) functional group and the carboxyl ( $-\text{COOH}$ ) functional group. This means amino acids have both acidic and basic properties.

The monomer  $\text{H}_2\text{N}-(\text{CH}_2)_5-\text{COOH}$  used to make nylon-6 has an amine and an acid functional group but it is not classified as an amino acid because amino acids have two specific structural features that are not present in this molecule.

The special structural features common to the 20 amino acid monomers that form proteins are:

- ▶ the amine and carboxyl functional groups are attached to the same carbon atom (called the **alpha-carbon**)
- ▶ a hydrogen attached to the alpha-carbon.

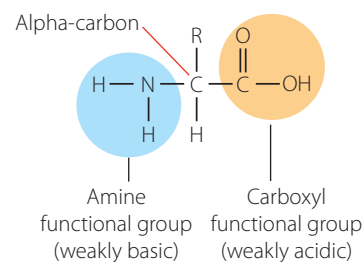
The simplest amino acid is glycine, which has the structure:



These monomers are **alpha-amino acids** because they can only form proteins when the two functional groups are joined to the same carbon atom. The general structure of an alpha-amino acid is shown in Figure 13.20.

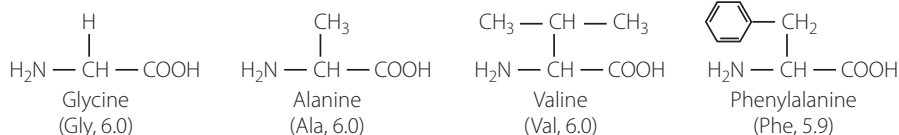
The 'R' group is a carbon-containing side chain. The 20 amino acids commonly found in proteins can be categorised into three broad groups. They are amino acids with:

- ▶ non-polar R groups
- ▶ polar R groups capable of forming ions (generally with an additional  $\text{—NH}_2$  or  $\text{—COOH}$  groups as part of the R chain)
- ▶ polar R groups that generally do not form ions (generally with an  $\text{—OH}$  or  $\text{—SH}$  group as part of the R chain) (as shown in Figure 13.21).

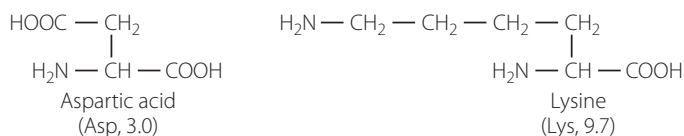


**FIGURE 13.20** General structure of an alpha amino acid

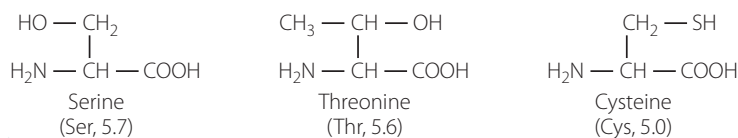
**a** With non-polar groups:



**b** With polar R groups that form ions:



**c** Polar R groups that do not generally form ions:



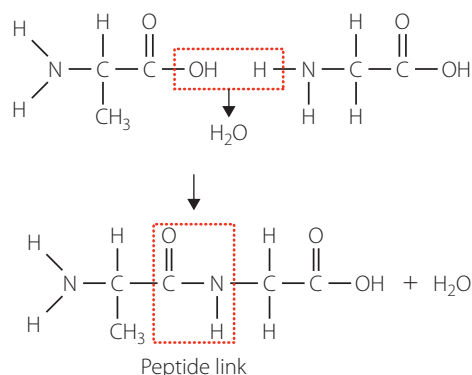
**FIGURE 13.21** Common amino acids found in proteins. Their usual abbreviations are given in brackets along with their isoelectric points (the pH at which they exist as the neutral molecule).

When drawing an alpha-amino acid, the amine group is always written on the left and the carboxyl group is always written on the right.

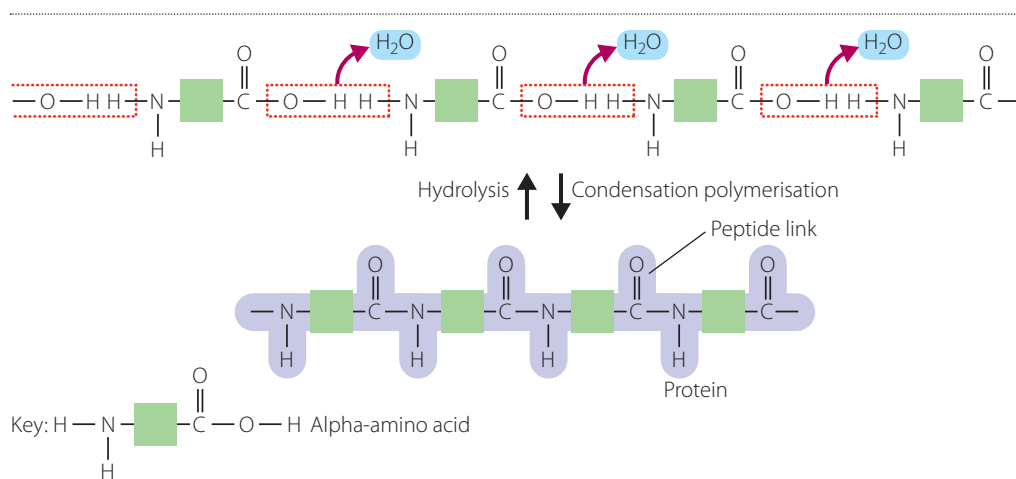
Amino acids undergo condensation polymerisation to form an amide in the same way as nylon. The bonds that hold amino acids together are covalent bonds.

The link that joins two amino acids together is called a **peptide link** (and is the same as the amide link in polyamides). The compound formed when two amino acids join together is called a **dipeptide** and when long chains of amino acid units join, the result is a polypeptide.

For example, when glycine reacts with alanine, the result is the alanylglycine dipeptide:



The resultant dipeptide has functional groups at each end, so it can continue to react with other amino acids to produce a polypeptide, as shown in Figure 13.22.



**FIGURE 13.22** Forming a polypeptide and breaking it down again



New polymers

Unlike nylons, which have a regular repeating unit, polypeptides can have various combinations of amino acids. Biochemists have developed a shorthand way of drawing them. Each of the 20 amino acids that make up the body's proteins has been given a three-letter abbreviation, as can be seen in the examples in Figure 13.21. The dipeptide alanylglycine, shown above, can be written as Ala—Gly. A possible sequence of a peptide with eight amino acids is Lys—Cys—Asp—Cys—Gly—Val—Val—Thr.

When hundreds to thousands of amino acid units join together, the result is a protein. So proteins are giant polypeptides. In the final protein, there is still an amine group at one end and a carboxyl group at the other.

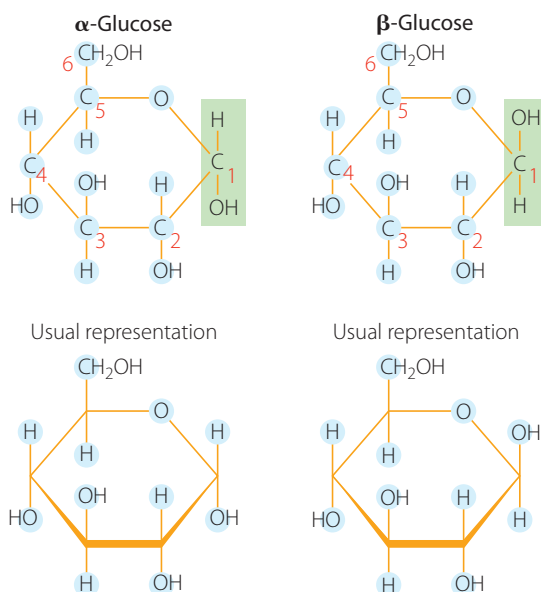
In the laboratory, proteins can be broken down by warming them with some strong hydrochloric acid but the breakages are non-specific.

## Polymers of glucose

Glucose is one of the simple sugars, called monosaccharides, from which complex carbohydrates are made. The other two monosaccharides are fructose and galactose. These monosaccharides can form a single linkage with another monomer to form disaccharides or they can form many linkages with other monomers to form polysaccharides. The link that joins the monosaccharides is called a **glycosidic link**,  $-\text{C}-\text{O}-\text{C}-$ .

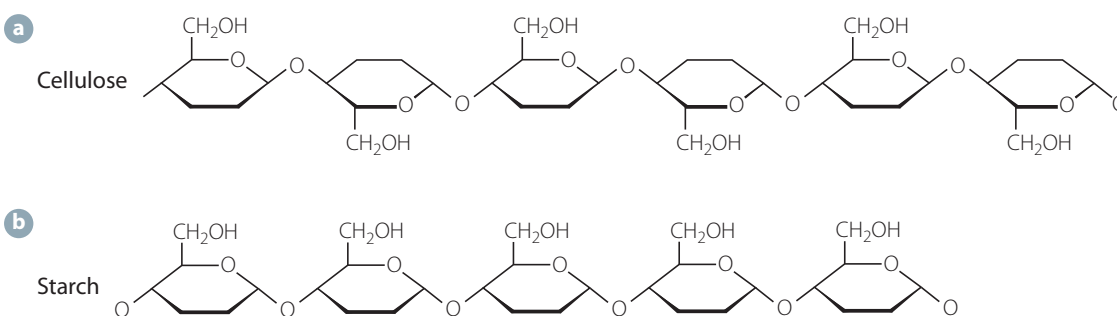
Glucose itself has two isomers. These are  $\alpha$ -glucose and  $\beta$ -glucose, which are shown in Figure 13.23.

The three most important polysaccharides are starch and cellulose from plants and glycogen from animals. These polysaccharides are all polymers of glucose but have different glycosidic links and different amounts of branching of the polymer chain and degree of polymerisation.



**FIGURE 13.23** The  $\alpha$  and  $\beta$  form of glucose

The nature of the glycosidic linkage is different because cellulose consists of long chains of  $\beta$ -glucose joined together (Figure 13.24a), while starch and glycogen consist of  $\alpha$ -glucose molecules joined together (Figure 13.24b).



**FIGURE 13.24** The structures of cellulose and starch

The starch polymer consists of two parts. The smaller part (about 20%), amylose, is a straight-chain polymer that can form spirals due to intrachain hydrogen bonding. Amylopectin, which forms the major part (80%), is a highly branched chain. These chains occur when one glucose molecule condenses with three other glucose molecules instead of the normal two. This part of the molecule cannot form spirals.

Cellulose has unbranched molecules that preferentially form hydrogen bonds with each other to form a strong cross-linked type structure. This cross-linking gives cellulose its strength and rigidity. Unlike starch, cellulose is insoluble in water. Cellulose is a highly crystalline polysaccharide, which accounts for many of its properties.

Glycogen is highly branched with an amorphous structure.

- The primary, secondary, tertiary, and sometimes quaternary, structures of proteins determine their properties and biological functions.
- In humans and other animals, proteins are broken down (hydrolysed) during digestion into their constituent amino acids. This process is brought about by enzymes (which are themselves proteins), some of which will only break the peptide link between specific amino acids.



Dominoes



Check your understanding

- 1 Distinguish between a natural and synthetic polymer.
- 2 Draw the general structure of an alpha-amino acid.
- 3 Compare the structures of alanine and serine.
- 4 Use the structures in Figure 13.21 to draw the structure for the peptide with the following amino acid sequence: Lys—Cys—Asp—Cys.
- 5 Distinguish between the structures of  $\alpha$ -glucose and  $\beta$ -glucose.
- 6 Compare the structures of starch and cellulose.

**CHECK YOUR UNDERSTANDING**

13.5

## IMPORTANT NEW TERMS

After studying this chapter you should know the meaning of the following terms:

addition polymer (p. 371)

alpha-amino acid (p. 394)

alpha-carbon (p. 394)

amide link (p. 389)

amorphous (p. 373)

atactic (p. 378)

condensation polymer (p. 387)

copolymer (p. 380)

cross-linking (p. 383)

crystalline (p. 373)

dipeptide (p. 395)

glycosidic link (p. 396)

initiator (p. 372)

isotactic (p. 378)

monomer (p. 369)

peptide link (p. 395)

plastic (p. 368)

plasticiser (p. 377)

polyester (p. 387)

polymer (p. 368)

stereoregular polymer (p. 379)

syndiotactic (p. 378)

thermoplastic (p. 369)

thermosetting (p. 369)

vulcanisation (p. 383)

## AFTER STUDYING THIS CHAPTER YOU SHOULD KNOW:

- ▶ the definitions for all terms in the important new terms list
- ▶ the relationship between polymer and monomer
- ▶ the characteristics of addition and condensation polymerisation
- ▶ the differences between thermosetting and thermoplastic polymers
- ▶ the process by which addition polymers form
- ▶ the factors that influence the properties of a polymer
- ▶ how different structures of the same polymer affect its properties
- ▶ the processes by which condensation polymers form
- ▶ the linkages in polyesters and polyamides
- ▶ how amino acids bond to form polypeptides.

## YOU SHOULD BE ABLE TO:

- ▶ distinguish between addition polymerisation and condensation polymerisation
- ▶ identify and name polymers and monomers from their structures
- ▶ draw structures of monomers and polymers
- ▶ predict the properties of a polymer based on its structure
- ▶ relate structure and bonding in a polymer to its properties
- ▶ identify the main functional groups in monomers and predict the structure of the polymer that would form from these
- ▶ distinguish between a polyester and a polyamide.

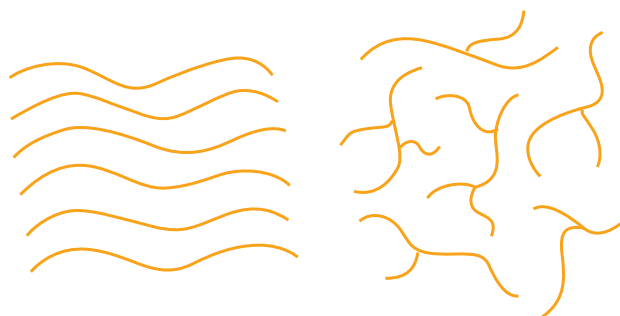
# 13 CHAPTER REVIEW QUESTIONS



Review quiz

- Describe the similarities and differences between addition and condensation polymerisation.
- Describe the differences between isotactic, atactic and syndiotactic versions of a polymer and relate these to the properties of the polymer.
- Explain how and why the following factors affect the property of a polymer.
  - Cross-linking
  - Branching
  - Side groups
- A linear polymer is one in which:
  - the chains are aligned parallel to each other.
  - there is no cross-linking.
  - there are many side branches.
  - the chains are very short.
- As the chain length of a polymer increases, the polymer becomes:
  - stronger.
  - less dense.
  - more easily melted.
  - more soluble.
- For a monomer to be able to undergo addition polymerisation, it should contain:
  - at least three carbon atoms.
  - both hydrogen and oxygen.
  - a multiple bond.
  - a halogen.
- When a polymer is formed by condensation polymerisation, the:
  - mass of the polymer formed is less than the total mass of reactants.
  - polymer must be linear.
  - polymer must be cross-linked.
  - polymer must be thermoplastic.
- Which of the following compounds is an amino acid?
  - Ethanoic acid
  - Alanine
  - Lactose
  - DNA
- What are the similarities and differences between an ester link, an amide link and a peptide link?
- Draw the general formula for an amino acid and explain how the R group influences the structure of a protein formed by particular amino acids.

- The arrangement of long-chain molecules in high-density and low-density polyethylene can be represented as shown.



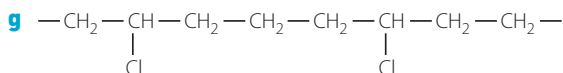
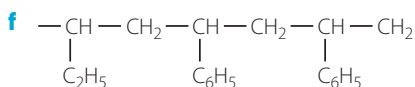
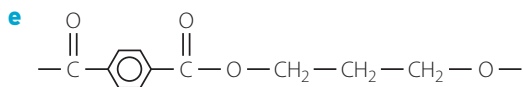
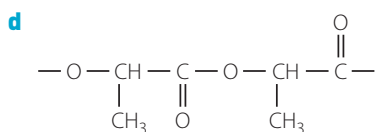
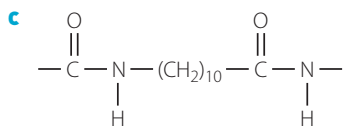
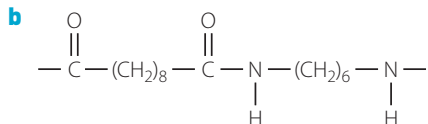
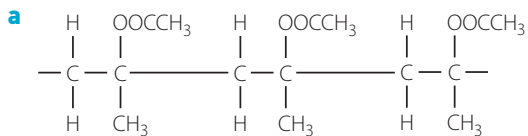
**FIGURE 13.25** The structures of HDPE (left) and LDPE (right)

- Explain what causes the difference in density between the two types of polyethylene.
  - Which form would you expect to have the greatest mechanical strength? Give your reasons.
  - Which type would be more suitable for:
    - a washing-up bowl?
    - a cordial bottle?
  - Explain why a polyethylene shopping bag is a greater hazard to the environment than a paper one.
- Teflon is the name given to the polymer used to coat kitchenware so it is non-stick. It is formed by reacting tetrafluoroethylene in the presence of a catalyst. In this process:
    - a condensation reaction takes place, producing the polymer and water.
    - a condensation reaction takes place, producing the polymer only.
    - an addition reaction takes place, producing the polymer and water.
    - an addition reaction takes place, producing the polymer only.
  - Which of the following molecules is most likely to undergo condensation polymerisation with itself?
    - $(\text{CH}_3)_3\text{COH}$
    - $\text{H}_2\text{N}(\text{CH}_2)_6\text{NH}_2$
    - $\text{ClOC}(\text{CH}_2)_4\text{COCl}$
    - $\text{H}_2\text{N}(\text{CH}_2)_5\text{COOH}$
  - What types of intermolecular forces would you expect in:
    - polypropylene?
    - poly(vinyl chloride)?
    - nylon?
    - PET?



15 For each of the structures shown:

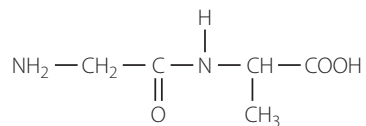
- i draw the structure of the monomer(s) from which it is produced  
 ii identify the type of polymerisation.



16 Draw the structures of the polymers formed from the following monomers.

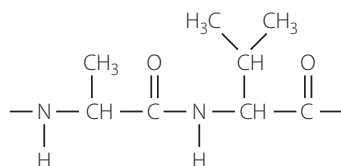
- a**  $\text{CHF}=\text{CH}_2$   
**b**  $\text{H}_2\text{N}-(\text{CH}_2)_3-\text{NH}_2$  and  $\text{HOOC}-(\text{CH}_2)_4-\text{COOH}$   
**c**  $\text{HO}-\text{CH}_2\text{CH}_2-\text{OH}$  and  $\text{HOOC}-\text{CH}_2-\text{COOH}$   
**d**  $\text{CH}_3\text{CH}(\text{CH}_2)\text{HC}=\text{CH}_2$

17 Two amino acids glycine (Gly) and alanine (Ala) join to form the dipeptide glycylalanine (Gly—Ala) as shown.



Copy the diagram and circle and name the bond that joins the two amino acids together.

18 Consider the following section of a protein chain.



Draw and name the amino acids that reacted to produce this section of the protein.

19 Predict the type of bonding, if any, that would occur between the polymer chains in question 15 a and b.

20 Justify why an understanding of polymers is required in biochemistry.

21 Justify, in terms of its structure, why cellulose is the major component in the cell wall of plant cells.

## Answer the following questions.

- 1** Name and draw the structures of:
- two position isomers of 1-hexanol
  - two isomers of 1-octene that are both chain and position isomers; explain the structures you have drawn
  - two functional group isomers of pentanoic acid.
- 2** Write equations for the following reactions, naming all organic products.
- Propene and hydrogen
  - 2-butyne and bromine
  - 3-hexene and water
  - The complete combustion of ethanol
  - Ethane and chlorine to form 1,1,1-trichloroethane
  - Dehydration of 1-butanol
  - 2-hexanol and hydrogen chloride
  - 1-propanol and acidified dichromate ions
  - Fermentation of glucose
  - Ethanoic acid with sodium carbonate
  - Propyl methanamine with hydrochloric acid
- 3** A chemist had three liquids – ethanol, butanoic acid and pentanal – but did not know which was which, so called them P, Q and R.
- When acidified dichromate ions were added to all substances, the mixtures with P and Q changed colour from orange to green, while the mixture with R remained orange.
- When drops of sodium carbonate were added to fresh samples of the three liquids, R produced bubbles of colourless gas but P and Q did not.
- Samples of P and Q were added to water. It was observed that P was soluble in water, while Q was not.
- Identify P, Q and R, justifying your answer and writing equations for any reactions that occurred.
- 4** Explain the following observations and trends seen within and between classes of organic molecules.
- All classes of organic molecules increase their melting and boiling points as the length of the hydrocarbon chain component of the molecule increases.
  - Short-chain alcohols and carboxylic acids are very soluble in water, but solubility decreases as the length of the hydrocarbon chain increases.
  - The properties of tertiary amides are different from the properties of primary and secondary amides.

- 5** A student wanted to prepare the ester pentyl butanoate.
- Identify the alcohol and carboxylic acid the student would use and write an equation to represent the reaction that would occur. Identify any other chemicals required.
  - Draw the apparatus used to react the alcohol and carboxylic acid together, labelling each part and explaining how it is used.
  - Explain why the final mixture would contain both reactants and products.
  - Outline a method you would use to purify your ester.
  - Identify how and why you would use a SDS when planning this investigation.
- 6** Outline the reagents you would use to distinguish between the following molecules. Write equations for any reactions that occur. Show clearly the observations that you would make.
- Ethanol and 2-methyl-2-propanol
  - Pentanoic acid and 2-pentanone
  - Pentane and 2-pentene
  - Propanal and propanone
- 7** A student wanted to compare the heat energy produced by different fuels. They conducted an investigation and measured the following data:

FUEL	INITIAL MASS FUEL (g)	FINAL MASS FUEL (g)	INITIAL WATER TEMP. (°C)	FINAL WATER TEMP. (°C)
Methanol	33.1	29.5	21.4	42.8
1-propanol	37.4	35.1	18.3	37.5
2-pentanol	32.9	30.3	20.1	39.9

- Calculate the heat energy produced in  $\text{kJ mol}^{-1}$  for each fuel if 300 mL water was heated in each case.
- Identify an alternative unit that could be used to compare these fuels and why it would give a better comparison than using units of  $\text{kJ mol}^{-1}$ .
- Predict whether the heat energy values you calculated would be below or above the true value. Give two reasons, other than incomplete combustion of the fuel, why a significant discrepancy would occur.
- Incomplete combustion occurs when oxygen is limited. Outline problems for human health that arise from incomplete combustion of fuels.

**8** Describe how to produce the following substances. In your answer, identify any reagents needed, conditions required for the reaction to occur and write equation/s to show the production of the named chemical.

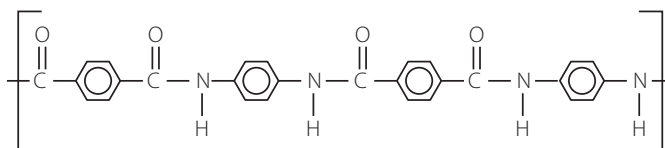
- a** Hexanal from an alkene
- b** 3-pentanol from an alkane
- c** Butanoic acid from an alkane
- d** Propyl pentanoate from two different alkenes

**9** Bioethanol and biodiesel are both used as either fuel additives or as alternative fuels.

- a** Compare the production of bioethanol and biodiesel.
- b** Outline why biodiesel and bioethanol are considered to be better for the environment than fossil fuels.
- c** Outline three possible global consequences of the use of fossil fuels as fuels for vehicles.

**10** Polymers can occur as either addition polymers or condensation polymers.

- a** Distinguish between addition and condensation polymerisation.
- b** Using equations, explain how long chain fractions of crude oil can be converted to polyethylene.
- c** Justify, in terms of structure and properties, why LDPE and HDPE have very different uses.
- d** Below is the structure for Kevlar, a strong and heat-resistant fibre.



- i** Draw the structure of the monomers used to make Kevlar.
- ii** Compare the structures of the monomers used to make Kevlar with those used to make nylon-6,6.

## DEPTH STUDY SUGGESTIONS

- Perform a series of investigations to distinguish between different families of organic compounds.
- Conduct research into the implications of obtaining and using hydrocarbons.
- Conduct research into the production and/or use of biofuels.
- Conduct an investigation to compare the energy produced by a variety of fuels.
- Conduct an investigation into factors affecting the rate of fermentation of glucose.
- Conduct an investigation comparing the action and properties of soaps and detergents.
- Investigate thirsty polymers, including hydrogels.
- Create an animation/cartoon to explain polymerisation.

## » MODULE EIGHT

# APPLYING CHEMICAL IDEAS

- 14 Analysis of inorganic substances
- 15 Analysis of organic substances
- 16 Chemical synthesis and design



## 14

## Analysis of inorganic substances

## INQUIRY QUESTION

How are the ions present in the environment identified and measured?

## Students:

analyse the need for monitoring the environment **S CCT ICT**

conduct qualitative investigations – using flame tests, precipitation and complexation reactions as appropriate – to test for the presence in aqueous solution of the following ions: **N**

– cations: barium ( $\text{Ba}^{2+}$ ) calcium ( $\text{Ca}^{2+}$ ) magnesium ( $\text{Mg}^{2+}$ ) lead(II) ( $\text{Pb}^{2+}$ ) silver ion ( $\text{Ag}^+$ ) copper(II) ( $\text{Cu}^{2+}$ ) iron(II) ( $\text{Fe}^{2+}$ ) iron(III) ( $\text{Fe}^{3+}$ )

– anions: chloride ( $\text{Cl}^-$ ) bromide ( $\text{Br}^-$ ) iodide ( $\text{I}^-$ ) hydroxide ( $\text{OH}^-$ ) acetate ( $\text{CH}_3\text{COO}^-$ ) carbonate ( $\text{CO}_3^{2-}$ ) sulfate ( $\text{SO}_4^{2-}$ ) phosphate ( $\text{PO}_4^{3-}$ )

conduct investigations and/or process data involving:

- gravimetric analysis
- precipitation titrations

conduct investigations and/or process data to determine the concentration of coloured species and/or metal ions in aqueous solution including but not limited to, the use of:

- colourimetry
- ultraviolet–visible spectrophotometry
- atomic absorption spectroscopy.

Chemistry Stage 6 Syllabus © NSW Educational Standard Authority for and on behalf of the Government of New South Wales, 2017





There is increasing concern that the environment is becoming more polluted. An Internet search using the terms 'water contamination Australia' gives millions of results, as do searches for air and soil contamination. There are regular media reports of the use of toxic chemicals, such as firefighting foam and chemical spills, which result in contamination of waterways and soil. State and federal government organisations, such as the NSW Environmental Protection Authority (EPA), are primarily responsible for monitoring the environment for the safety and health of the population. Pollutants can be generally classified as inorganic or organic substances. This chapter will focus on the identification and measurement of inorganic substances.

**FIGURE 14.1**  
Collecting samples  
of water potentially  
contaminated by toxic  
material



Prior knowledge

## 14.1 Why monitor the environment?

In order to manage and control the pollution problems, the sources of pollution and types of pollutants need to be known. A substance is considered to be a pollutant when its introduction into the environment has undesired effects on the environment or the resources of that environment. Even substances naturally present in the environment can become pollutants if their concentrations exceed levels agreed to in regulations. For example, ozone in the upper atmosphere is important because it stops ultraviolet radiation reaching the Earth's surface; however, ozone at ground level is considered to be a pollutant because it can damage vegetation and cause health problems.

Australia, like many countries, has national guidelines for freshwater (including drinking water), groundwater and marine water quality. These are defined acceptable levels for biological, physical and chemical parameters, which are monitored to ensure protection of plants and animals in the environment. Australia also has national air quality standards and standards related to soil quality. Testing by chemists helps maintain national standards of quality and safety (Figure 14.2).

**FIGURE 14.2**  
Chemists working  
in an analytical  
laboratory





## Pollution due to chemical spills

Industries are responsible for monitoring and managing the products of their processes to minimise any environmental damage. Many chemicals around the house or in the school laboratory are produced by industrial chemical processes. Chemicals that are produced on a large scale include acids such as sulfuric acid and nitric acid. Bases such as sodium hydroxide, lime and sodium carbonate are also produced in large volumes. Many of these chemicals are then used in other processes (for example, fertiliser and metal production).

The major environmental issue in the production, transport, use and storage of these chemicals is what happens in case of a spill. Spills can be caused by fires, explosions, leaks or damage to transport vehicles or storage tanks. The consequences of a spill may be long term if the chemicals cannot be contained. In April 2017, 22 000 litres of firefighting foam containing toxic chemicals was accidentally released into the Brisbane River and was believed to be responsible for the death of many marine organisms. There is ongoing monitoring of the water quality in the area and people were advised not to consume seafood caught in the area. The use of this foam over a number of years at air force bases across Australia has led to contamination of soil and ground water and poses a danger to the populations living in the vicinity of these bases. Ongoing monitoring of water and soil quality is important to determine the extent of the contamination and for the health of the population.

The general population may also be responsible for increasing pollution of the environment. Herbicides, pesticides, paints and other toxic chemicals should not be released into wastewater or storm water drains because these chemicals eventually end up in waterways.

## Pollution due to fertilisers

Excess use of fertilisers can also cause problems. As fertilisers are washed off gardens and agricultural fields, they often make their way into lakes and rivers. Phosphates and nitrates are nutrients for algae that live in waterways. The enrichment of waterways by addition of these nutrients is called eutrophication. When excess nutrients from fertilisers are released into a waterway, algae can experience fast growth rates. In extreme situations, the algae form thick layers on the surface of the water, as seen in Figure 14.3.



**FIGURE 14.3** Algal blooms on waterways



When thick algal blooms form, sunlight is prevented from entering the water. Plants that grow underwater cannot photosynthesise without sunlight, so they die. Reduction of photosynthesis from underwater plants results in a lack of oxygen in the water. A lack of oxygen in the water means animals such as fish will also die because they have no oxygen to breathe. As the animals and the algae die, they undergo anaerobic decay in the low oxygen environment. This results in the production of toxic chemicals such as methane, ammonia, hydrogen sulfide and phosphine. These chemicals poison the waterways so they are unsafe for drinking, recreation or as a water supply for agriculture.

Problems with eutrophication have become so severe that, in some places, the use of fertilisers is regulated. In some parts of the United States, the waterways are so polluted that householders are banned from using fertilisers in their gardens to prevent run-off into the river systems. In Australia, the Murray River suffers from algal blooms, and farmers are sometimes asked to limit fertiliser use or prevent run-off into the river to decrease the amount of nutrients available to the algae.

- It is important to monitor the environment for pollutants that may affect the health of plants and animals so problems can be addressed.

- 1 Explain why it is important to monitor the environment.
- 2 List two sources of pollution and describe how these affect the environment.
- 3 Explain why it is important to have water quality guidelines.
- 4 Suggest how naturally occurring substances can become pollutants.

#### CHECK YOUR UNDERSTANDING

14.1

## 14.2 Identifying ions in solution

Chemists may be required to identify inorganic substances that have either accidentally or deliberately contaminated food, water or soil. When conducting water quality testing, chemists need to identify which substances are present and then determine the levels of those that may present a danger to the populations in contact with the water.

For example, in August 2017, it was revealed that water from an old mine site was escaping into Sydney's drinking water catchment. The scientists conducting the testing reported high levels of manganese, zinc, iron and sulfates.

There are a number of tests that are carried out to qualitatively identify the presence of particular cations and anions. These include flame tests and the use of precipitation reactions. Tests to determine the quantities of substances present include precipitation titrations, gravimetric analysis, and the use of instrumental techniques. All these tests and techniques will be discussed throughout this chapter.

### Revisiting precipitation reactions and solubility data

In chapter 10 of *Chemistry in Focus Year 11*, you learnt that precipitation reactions are ones in which a solid forms when two solutions are mixed. In *Chemistry in Focus Year 12* (chapter 4, p. 94) solubility rules were used to predict and analyse the composition of substances formed by precipitation reactions.

Precipitation reactions are useful for finding out whether a particular cation or anion is present. For example, chemists could test for lead or barium in water supplies. Precipitation reactions can also be used to remove unwanted substances from water.

**Toxic water**  
Learn more about the research being conducted into water escaping from a derelict mine site Sydney.

You may like to revisit the work already done on solubility rules and precipitants in section 4.5 p. 94.

The data in Table 14.1 can be used to predict whether or not a precipitate will form when particular solutions are mixed.

**TABLE 14.1 Solubility of ionic compounds at standard laboratory conditions (SLC)**

ANION	$\text{Cl}^-$ , $\text{Br}^-$ , $\text{I}^-$	$\text{S}^{2-}$	$\text{OH}^-$	$\text{SO}_4^{2-}$	$\text{CO}_3^{2-}$ $\text{PO}_4^{3-}$ $\text{SO}_3^{2-}$	$\text{CH}_3\text{COO}^-$	$\text{NO}_3^-$
High solubility (aq) $\geq 0.1 \text{ mol L}^{-1}$	Most	Group 1, group 2 $\text{NH}_4^+$	Group 1, $\text{Sr}^{2+}$ , $\text{Ba}^{2+}$ , $\text{NH}_4^+$	Most	Group 1, $\text{NH}_4^+$	Most	All
Low solubility (s) $< 0.1 \text{ mol L}^{-1}$	$\text{Ag}^+$ , $\text{Pb}^{2+}$ , $\text{Cu}^{2+}$	Most	Most	$\text{Ag}^+$ , $\text{Pb}^{2+}$ , $\text{Ca}^{2+}$ , $\text{Ba}^{2+}$ , $\text{Sr}^{2+}$	Most	$\text{Ag}^+$	None

Not the following notes on the solubility rules are also helpful.

- All group 1 compounds and all ammonium compounds have a high solubility in water.
- The compounds silver acetate, lead(II) chloride, calcium sulfate, silver sulfate and calcium hydroxide are sparingly soluble (that is, have a solubility range  $1\text{--}10 \text{ g L}^{-1}$ ) so may not precipitate if they are present in very low concentrations.
- $\text{Pb}^{2+}$ ,  $\text{Ba}^{2+}$ ,  $\text{Cu}^{2+}$  and  $\text{Ag}^+$  will not precipitate with  $\text{PO}_4^{3-}$  in solutions where the  $\text{pH} < 2$ .

As pointed out in chapter 4, it is also important to remember that sometimes when only a small amount of precipitate is formed, it may stay in suspension and make the mixture look cloudy. Therefore, if mixing two clear solutions produces cloudiness, then a precipitate is considered to have formed.

The use of solubility data and precipitation reactions for identifying unknown cations and anions in solution will be considered in more detail in the following sections.

- Precipitation reactions can be used to identify the presence of particular cations and anions in solution.

## CHECK YOUR UNDERSTANDING

14.2

- 1 Write the definition of a precipitation reaction.
- 2 Explain why the presence of sparingly soluble salts may not be detected.
- 3 Which of the following substances are soluble in water?
  - a Sodium hydroxide
  - b Aluminium oxide
  - c Copper(II) sulfate
  - d Silver carbonate
  - e Lithium chloride
- 4 Write overall equations for the reactions (if any) that occur when solutions of the following pairs of substances are mixed. If there is no reaction, write 'NR'.
  - a Sodium chloride and silver nitrate
  - b Copper(II) sulfate and potassium hydroxide
  - c Nickel(II) chloride and potassium sulfate
  - d Sodium carbonate and iron(II) sulfate
  - e Zinc nitrate and ammonium sulfide
  - f Potassium carbonate and calcium chloride

## 14.3 Identifying cations in solution

Cations are usually metals ions; for example, barium ( $\text{Ba}^{2+}$ ), iron(II) ( $\text{Fe}^{2+}$ ). However, there are two important exceptions: ammonium ( $\text{NH}_4^+$ ) and hydronium ( $\text{H}_3\text{O}^+$ ). In this section, the focus will be on qualitative testing to identify the following ions in aqueous solution.

- ▶ Barium ( $\text{Ba}^{2+}$ )
- ▶ Calcium ( $\text{Ca}^{2+}$ )
- ▶ Magnesium ( $\text{Mg}^{2+}$ )
- ▶ Lead(II) ( $\text{Pb}^{2+}$ )
- ▶ Silver ( $\text{Ag}^+$ )
- ▶ Copper(II) ( $\text{Cu}^{2+}$ )
- ▶ Iron(II) ( $\text{Fe}^{2+}$ )
- ▶ Iron(III) ( $\text{Fe}^{3+}$ )

While cations in solution are primarily identified by precipitation reactions, other tests including flame tests and complexation reactions (page 417) are also used to identify the presence of specific cations. It is usual to combine results from these tests for confirmation of the presence of particular cations.

### Using flame tests

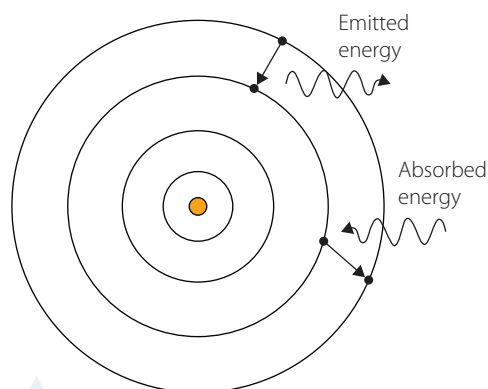
As you learnt in chapter 3 of *Chemistry in Focus Year 11*, the electrons of atoms exist in energy levels and each element has its own unique electron configuration. When an atom absorbs energy, such as heat, the electrons in the energy levels around the nucleus gain this extra energy and can move up to a higher energy level.

Since an atom can have multiple energy levels, it is possible for an electron to move up one, two or even more energy levels. An atom with electrons in upper energy levels is said to be in an **excited state**. Electrons in the excited, higher energy levels are unstable. After a very short time, less than one-millionth of a second, the electrons move down to their original energy levels or **ground state**. As they do, they release the energy that they previously absorbed. This is shown in Figure 14.4.

The energy that the electrons release is emitted as light. Because the electrons of an atom occupy a number of different energy levels, jumps between these different levels result in different amounts of energy being released.

Energy is related to the **wavelength** of the light produced, so this light has a very specific wavelength. Because the electrons can move between numbers of different levels, different wavelengths of light are emitted from a sample and a spectrum of lines is produced. Each element has its own unique spectrum because it has its own unique set of energy levels and **electron configuration**.

When the electrons move between energy levels, it will involve absorption and emission of different amounts of energy. This means that every element will emit light of a different set of wavelengths from every other element. Because every atom of the same element has the same set of energy levels, the pattern produced for an element will always be the same. This is a way of identifying elements. An unknown element is heated and the light it emits is analysed and compared with known spectra.



**FIGURE 14.4** Absorption and emission of light by atoms due to electron movement

Energy levels were explained in *Chemistry in Focus Year 11*, chapter 3, p. 54 and orbitals were explained in *Chemistry in Focus Year 11*, chapter 3, p. 60. Refer back to these sections to revise the concepts.

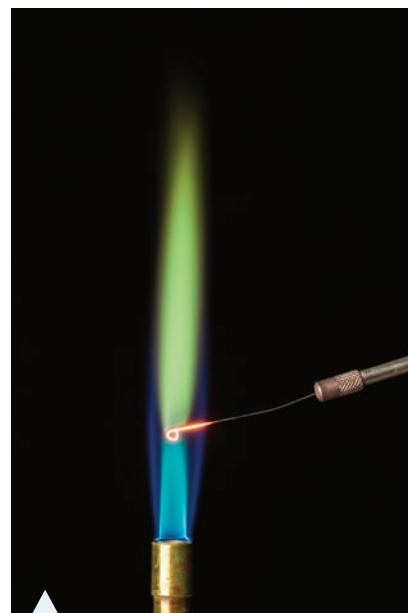
Sometimes the wavelength of light emitted as excited electrons return to their ground state is in the visible region of the electromagnetic spectrum. When this occurs, the element will produce a distinctive colour.

In a flame test, a sample is placed in a high energy flame such as that produced by a blowtorch or a Bunsen burner. Some of the metal ions in the sample regain their valence electrons to become neutral atoms. The colours produced in a flame are due to the electrons of the neutral atom falling back to their ground state, as shown in Figure 14.5.

It is only some metal elements that produce visible flame colours so flame tests can only be used to confirm the presence of particular metals or their cations. Flame tests are not useful for identifying anions.

While flame tests are simple to conduct it is sometimes difficult to distinguish between elements that produce similar colours. For example, barium produces a pale green flame, while copper produces a green flame and zinc a whitish green flame.

Table 14.2 lists the flame colours of some elements. Magnesium and silver do not produce a coloured flame.



**FIGURE 14.5** The flame colour produced by barium

**TABLE 14.2** Flame colours of some elements

ION	FLAME COLOUR
$\text{Ca}^{2+}$	Brick-red (orange-red)
$\text{Ba}^{2+}$	Pale green (apple green)
$\text{Cu}^{2+}$	Blue (halides); green (others)
$\text{Pb}^{2+}$	Light blue-grey
$\text{Fe}^{2+}$	Gold when very hot, bright blue or green turning to orange-brown
$\text{Fe}^{3+}$	Orange-brown

## INVESTIGATION 14.1

### Flame tests

#### INTRODUCTION

Some elements give a characteristic colour when placed into the flame of a Bunsen burner. These different colours can be used to identify the presence of different metals cations.

#### AIM

Write an aim for this investigation.

#### HYPOTHESIS

Write a hypothesis for this investigation.



## » MATERIALS

- 1 mol L<sup>-1</sup> hydrochloric acid
- Solid samples of:
  - Copper(II) sulfate
  - Copper(II) chloride
  - Calcium nitrate
  - Calcium chloride
- Barium chloride
- Barium nitrate
- Lead(II) nitrate
- Iron(II) nitrate
- Iron(III) compound
- Distilled water
- Nichrome wire loop mounted in a piece of glass tubing
- 2 × 150 mL beakers
- Bunsen burner
- Heat-proof mat
- Matches

Use the program RiskAssess or an equivalent source to determine how to safely handle each of the chemicals listed above. Add this to the risk assessment below.

WHAT ARE THE RISKS IN DOING THIS INVESTIGATION?	HOW CAN YOU MANAGE THESE RISKS TO STAY SAFE?
Bunsen burner flame is hot, so could cause burns.	Turn off the Bunsen burner or turn it to a yellow flame when not in use. Handle hot objects with care and do not place them directly onto bench tops; use a heat-proof mat.
Use of chemicals	



What other risks are associated with your investigation? How can you manage these?

## METHOD

- 1 Place some of the distilled water into a 150 mL beaker so that the nichrome loop can be completely submerged.
- 2 Place some of the hydrochloric acid into a 150 mL beaker so that the nichrome loop can be completely submerged.
- 3 Clean the nichrome loop by placing it into the distilled water first, then into the hydrochloric acid.
- 4 Light the Bunsen burner and turn it to the blue flame.
- 5 Place the nichrome loop into the flame. When the flame returns to its normal blue colour, the nichrome loop is clean.
- 6 Place the nichrome loop into the solid copper sulfate and then place it into the blue Bunsen flame.
- 7 Record the colour of the flame.
- 8 Repeat steps 3–7 for each of the solid chemicals.

## RESULTS

Present your results in an appropriate form.

## ANALYSIS OF RESULTS

- 1 Describe any patterns you can see in your results.
- 2 Describe any problems you had with determining the colours. Compare your results and observations with those of other groups.

## DISCUSSION

- 1 Explain why compounds containing the same elements will have the same colour flame when a flame test is conducted.
- 2 Explain any discrepancies between your results and the expected colours from Table 14.2.

## CONCLUSION

Write a conclusion linking elements and their flame colours.

## EXTENSION

A spectroscope can be used in a darkened room to view the flame. This will split the light emitted into its component wavelengths as emission spectra. These emission spectra can be compared to known patterns to confirm the element's identity.



### Fame tests of metal ions

Watch a video showing the flame test colours of different metal salts.

## Using precipitation reactions to identify cations

As shown in Table 14.3a and 14.3b, tests can be used to identify some cations. These tables are provided as alternative representations of the same tests. Only the cations listed in the table will be considered. Cations can be identified by observing whether or not precipitates are formed with particular anions according to the Table 14.1 (page 408). There are many different combinations that can be used to identify which of the cations is present in a solution.

Initially it will be assumed that only one cation is present in the sample. When multiple cations are present, the process becomes more complicated.

**TABLE 14.3a** Tests used to identify cations

CATION	TESTS
$\text{Ag}^+$	With $\text{OH}^-$ forms a brown milk coffee coloured precipitate <sup>a</sup> With $\text{Cl}^-$ forms a white precipitate that dissolves in ammonia solution
$\text{Pb}^{2+}$	With $\text{OH}^-$ forms a white precipitate which dissolves in excess $\text{OH}^-$ With $\text{Cl}^-$ forms a white precipitate (if solution not too dilute, say $0.05 \text{ mol L}^{-1}$ ) and this precipitate does not dissolve in ammonia solution With $\text{I}^-$ forms a yellow precipitate Gives a light blue-grey flame colour
$\text{Ba}^{2+}$	With $\text{SO}_4^{2-}$ forms a white precipitate Gives a pale green flame colour No precipitate with $\text{OH}^-$ or $\text{F}^-$ (compare $\text{Ca}^{2+}$ )
$\text{Ca}^{2+}$	With $\text{SO}_4^{2-}$ and $\text{OH}^-$ forms a white precipitate (if solution not too dilute, say $0.05 \text{ mol L}^{-1}$ ) With $\text{F}^-$ forms a white precipitate Gives a brick-red flame colour
$\text{Mg}^{2+}$	With $\text{OH}^-$ forms a white precipitate No precipitate with $\text{SO}_4^{2-}$
$\text{Cu}^{2+}$	With $\text{OH}^-$ forms a blue precipitate This precipitate dissolves in $\text{NH}_3$ to form a deep blue solution Gives a blue-green flame colour
$\text{Fe}^{2+}$	With $\text{OH}^-$ forms a green or white precipitate, which may turn brown <sup>b</sup> Decolourises acidified dilute potassium permanganate solution Gives a gold colour in a very hot flame, may also be bright blue or green turning to orange-brown
$\text{Fe}^{3+}$	With $\text{OH}^-$ forms a brown precipitate With thiocyanate ( $\text{SCN}^-$ ) forms a deep red solution Gives an orange-brown flame colour

<sup>a</sup>  $\text{AgOH}$  decomposes rapidly in solution to form hydrated  $\text{Ag}_2\text{O}$ , which is a milk coffee colour.

<sup>b</sup>  $\text{Fe}(\text{OH})_2$  most commonly forms a green precipitate; however, under some conditions it may be white. The green precipitate may gradually turn to brown  $\text{Fe}(\text{OH})_3$  as it is oxidised.



**TABLE 14.3b** Tests for cations

CATION	TESTS						
	OH <sup>-</sup>	Cl <sup>-</sup>	I <sup>-</sup>	F <sup>-</sup>	SO <sub>4</sub> <sup>2-</sup>	MnO <sub>4</sub> <sup>-</sup>	SCN <sup>-</sup>
Ag <sup>+</sup>	Brown milk coffee coloured precipitate <sup>a</sup>	White precipitate that dissolves in ammonia solution	Pale yellow precipitate	No precipitate	No precipitate (sparingly soluble)		
Pb <sup>2+</sup>	White precipitate which dissolves in excess OH <sup>-</sup>	White precipitate (if solution not too lute, say 0.05 mol L <sup>-1</sup> ) and this precipitate does not dissolve in ammonia solution	Yellow precipitate	No precipitate	White precipitate		
Ba <sup>2+</sup>	No precipitate	No precipitate	No precipitate	No precipitate	White precipitate		
Ca <sup>2+</sup>	White precipitate (if solution not too lute, say 0.05 mol L <sup>-1</sup> )	No precipitate	No precipitate	White precipitate	White precipitate (if solution not too lute, say 0.05 mol L <sup>-1</sup> )		
Mg <sup>2+</sup>	White precipitate	No precipitate	No precipitate	White precipitate	No precipitate		
Cu <sup>2+</sup>	Blue precipitate which dissolves in NH <sub>3</sub> to form a deep blue solution	No precipitate	No precipitate	No precipitate	No precipitate		
Fe <sup>2+</sup>	Green or white precipitate which may turn brown <sup>b</sup>	No precipitate	No precipitate	Precipitate	No precipitate	Decolourises acidified dilute potassium permanganate solution	
Fe <sup>3+</sup>	Brown precipitate	No precipitate	No precipitate	Precipitate	No precipitate		A deep red solution

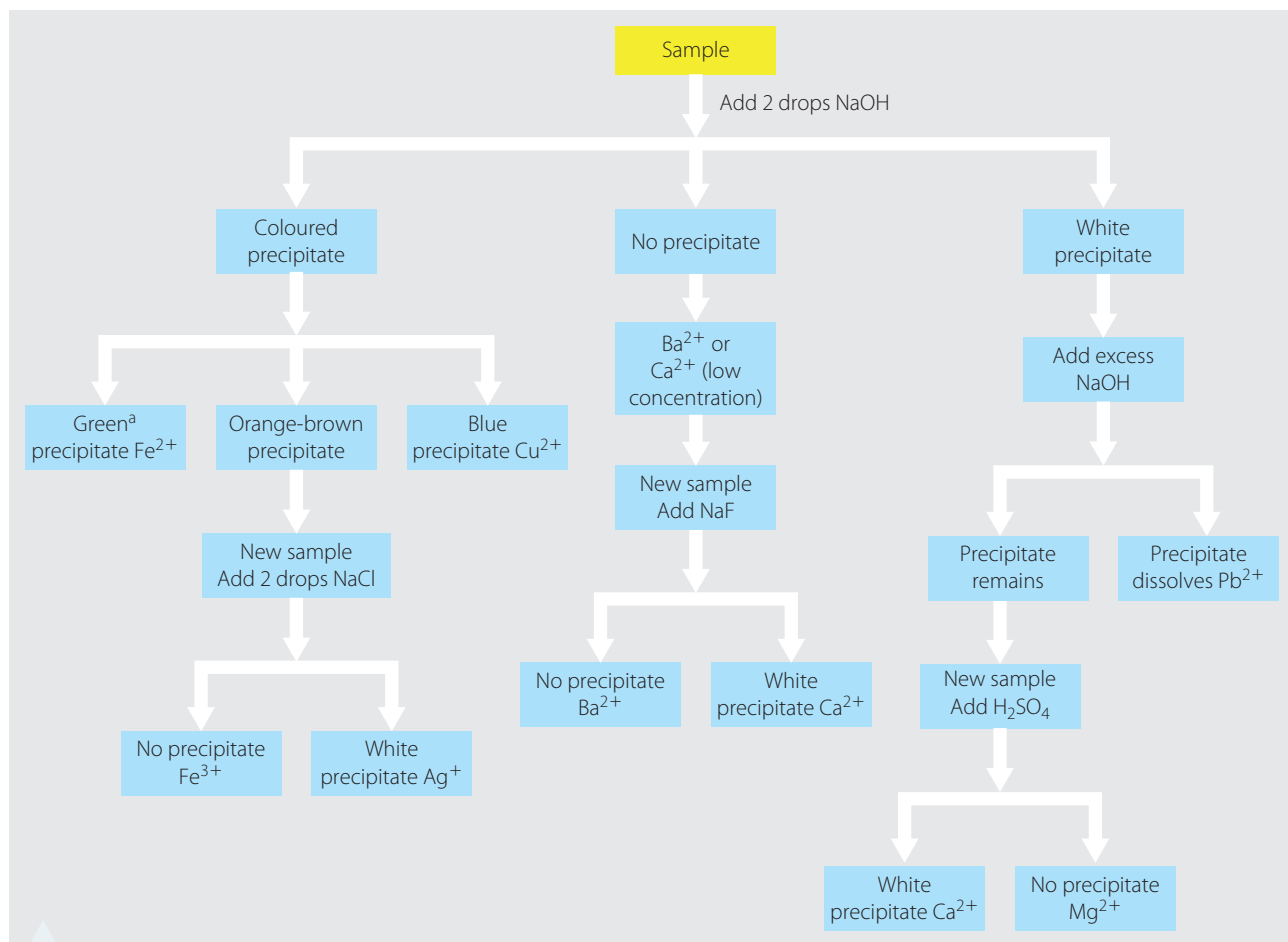
<sup>a</sup> AgOH decomposes rapidly in solution to form hydrated Ag<sub>2</sub>O, which is a milk coffee colour.

<sup>b</sup> Fe(OH)<sub>2</sub> most commonly forms a green precipitate; however, under some conditions it may be white. The green precipitate may gradually turn to brown Fe(OH)<sub>3</sub> as it is oxidised.

As can be seen in Tables 14.3a and 14.3b, there are many tests and combinations of tests that can be conducted to identify the cation present when a sample contains only one cation.

Figure 14.6 on page 414 gives one procedure for identifying the presence of the cation in a solution that contains only one cation.

- ▶ In Figure 14.6, Ca<sup>2+</sup> is considered twice, depending whether it is present in high or low concentrations due to the sparingly soluble nature of the salts produced. If it is present in high concentration, a white precipitate will form on addition of NaOH, while if only low concentrations are present, no precipitate will form. The presence of Ca<sup>2+</sup> can also be confirmed using a flame test.



**FIGURE 14.6** Flow chart for identifying the cation in a single cation sample solution

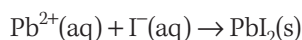
<sup>a</sup> The green precipitate of  $\text{Fe}(\text{OH})_2$  may go brown on standing.



Identifying cations

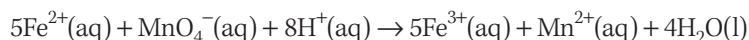
When the procedure in Figure 14.6 is followed the specific cation, of the eight being considered, is able to be identified. You can try this in Investigation 14.2. The presence of this specific cation could then be checked using either a flame test or an alternative precipitation reaction listed in Table 14.3a and 14.3 b.

For example, if  $\text{Pb}^{2+}$  is thought to be the ion present this can be confirmed by adding  $\text{I}^-$  to a fresh sample. The formation of a yellow precipitate of  $\text{PbI}_2$  will confirm the presence of lead:



Sometimes, especially if the sample being tested is not freshly made, it is difficult to distinguish between the presence of  $\text{Fe}^{2+}$  and  $\text{Fe}^{3+}$ . This is due to the ease by which  $\text{Fe}(\text{OH})_2$  oxidises to  $\text{Fe}(\text{OH})_3$ . Which of these two oxidation states of iron is present in the sample can be confirmed using the two additional tests listed in Table 14.3a and b.

Alternatively, the oxidation of  $\text{Fe}^{2+}$  to  $\text{Fe}^{3+}$  can be identified using an oxidising agent such as  $\text{MnO}_4^-$ . If  $\text{Fe}^{2+}$  is present, the addition of purple potassium permanganate ( $\text{KMnO}_4^-$ ) will result in decolourising the permanganate:



The presence of  $\text{Fe}^{3+}$  can be confirmed with the addition of potassium thiocyanate ( $\text{KSCN}$ ), resulting in the solution forming a blood red colour due to the formation of the  $\text{Fe}(\text{SCN})^{2+}$  ion. This reaction was studied when investigating Le Chatelier's principle in chapter 2.

## INVESTIGATION 14.2

### Identifying unknown cations

#### INTRODUCTION

In this experiment, you will conduct a series of tests to identify specified cations in a solution that contains only one cation. You will then use the results of these tests to identify an unknown cation in a sample.

#### AIM

To carry out a series of chemical reactions to identify the presence of the cations  $\text{Ag}^+$ ,  $\text{Mg}^{2+}$ ,  $\text{Ba}^{2+}$ ,  $\text{Ca}^{2+}$ ,  $\text{Pb}^{2+}$ ,  $\text{Cu}^{2+}$ ,  $\text{Fe}^{2+}$  and  $\text{Fe}^{3+}$  then use these results to identify the unknown cation in a sample.

#### MATERIALS

- Dropper bottles each containing one of the following  $0.1 \text{ mol L}^{-1}$  solutions:
  - Cation solutions ( $0.1 \text{ mol L}^{-1}$ )
    - $\text{AgNO}_3$
    - $\text{Mg}(\text{NO}_3)_2$
    - $\text{Pb}(\text{NO}_3)_2$
    - $\text{Ba}(\text{NO}_3)_2$
    - $\text{FeSO}_4$
    - $\text{CuSO}_4$
    - $\text{CaCl}_2$
    - $\text{FeCl}_3$
  - Test solutions ( $0.1 \text{ mol L}^{-1}$ )
    - $\text{NaOH}$
    - $\text{NaCl}$
    - $\text{H}_2\text{SO}_4$
    - $\text{NaF}$
    - $\text{KI}$
    - $\text{KSCN}$
    - Ammonia solution
    - Acidified  $\text{KMnO}_4$
- Three samples with unidentified cation
- 8 test tubes
- Test-tube rack
- Distilled water
- Safety glasses

WHAT ARE THE RISKS IN DOING THIS INVESTIGATION?	HOW CAN YOU MANAGE THESE RISKS TO STAY SAFE?
Concentrated $\text{NaOH}$ and $\text{H}_2\text{SO}_4$ are corrosive.	Wear safety glasses and personal protective clothing. Do not allow contact with skin or clothes. If contact occurs, wash with large amounts of water for 10–15 minutes.
Some metal salts (silver, barium, copper and lead) are poisonous. Silver nitrate will leave a brown stain on clothing and skin.	Avoid contact with skin and clothes. Wash hands thoroughly after use. Dispose of the chemicals as directed by your teacher.

What other risks are associated with your investigation? How can you manage these?

#### METHOD

- 1 Add 10 drops of each of the cation solutions to each of 8 test tubes.
- 2 Add 2 drops of the  $\text{NaOH}$  solution to each of the test tubes. If no precipitate forms, try adding a few more drops.
- 3 Record the results in the table below. If no precipitate forms, write 'NP'. If a precipitate forms write 'ppt' and state its colour.
- 4 In the test tubes where a precipitate formed, add excess  $\text{OH}^-$ . Record your observations.
- 5 Thoroughly clean all test tubes with distilled water.
- 6 Repeat steps 1–3 for  $\text{OH}^-$  where a precipitate formed; add excess  $\text{NH}_3$ . Record your observations. Thoroughly clean all test tubes.



- » **7** Repeat steps 1–3 using  $\text{SO}_4^{2-}$  instead of  $\text{OH}^-$ . Record your observations. Thoroughly clean all test tubes.
- 8** Add 10 drops of each of  $\text{Fe}^{2+}$  and  $\text{Fe}^{3+}$  solutions to separate test tubes. Add 2 drops of  $\text{SCN}^-$  to each test tube. Record the results.
- 9** Add 10 drops of each of  $\text{Fe}^{2+}$  and  $\text{Fe}^{3+}$  solutions to separate test tubes. Add 2 drops of acidified  $\text{MnO}_4^-$  solution to each test tube. Record the results.
- 10** Add 10 drops of  $\text{Ba}^{2+}$  and  $\text{Ca}^{2+}$  solution to separate test tubes and add 2 drops of  $\text{F}^-$  solution. Record the results.
- 11** Add 10 drops of  $\text{Ag}^+$  and  $\text{Pb}^{2+}$  solution to separate test tubes and add 2 drops of  $\text{Cl}^-$  solution. Record the results.
- 12** Add 5 drops to ammonia solution to each of the test tubes in step 11. Record the results.
- 13** Add 10 drops of  $\text{Pb}^{2+}$  solution to a test tube and add 2 drops of  $\text{I}^-$  solution. Record the results.
- 14** Obtain samples with unidentified cations and use the results to identify the cations.

### RESULTS

Copy and complete the following table.

CATIONS	TEST SOLUTION					
	$\text{OH}^-$	EXCESS $\text{OH}^-$	$\text{OH}^- + \text{EXCESS NH}_3$	$\text{SO}_4^{2-}$	ADDITIONAL TESTS	ADDITIONAL TESTS
$\text{Ag}^+$						
$\text{Mg}^{2+}$						
$\text{Pb}^{2+}$						
$\text{Cu}^{2+}$						
$\text{Ba}^{2+}$						
$\text{Ca}^{2+}$						
$\text{Fe}^{2+}$						
$\text{Fe}^{3+}$						
SAMPLE 1						
SAMPLE 2						
SAMPLE 3						

### DISCUSSION

- 1 Compare your results with the information provided in Table 14.3a or 14.3b. Explain any differences.
- 2 Explain how effective your identification of the unknown ions was. Provide reasons for success or failure of correct identification.
- 3 Redraw Figure 14.6 to include the results of additional tests.

### CONCLUSION

Comment on the effectiveness of the testing in identifying cations.

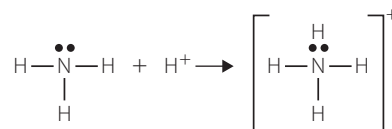
## Complexation reactions

Some of the compounds formed in the tests conducted involve the formation of **complex ions**. A reaction in which complex ions are formed is called a **complexation reaction**.

A complex ion, sometimes referred to as a complex, is formed when one or more small molecules or ions attach themselves to a central cation. The central cation is often, but not always, a transition metal ion. The surrounding molecules and ions, called ligands, must contain at least one lone pair of electrons. The resultant complex has different properties to the central cation, attached molecules and ions.

The ligand molecule or ion acts as an electron pair donor. The bond between the metal ion and ligand is a coordinate covalent bond, where both electrons are donated by the ligand.

Coordinate covalent bonds are formed when one atom does not have a complete outer shell (for example,  $\text{H}^+$  bonds to another atom that has a full outer shell containing at least one unshared electron pair). This is the type of bond formed between  $\text{H}^+$  and  $\text{H}_2\text{O}$  in the hydronium ion ( $\text{H}_3\text{O}^+$ ) and between  $\text{H}^+$  and  $\text{NH}_3$  in the ammonium ion ( $\text{NH}_4^+$ ). Figure 14.7 shows the formation of a coordinate covalent bond in  $\text{NH}_4^+$ .

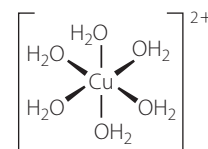


**FIGURE 14.7** Example of the formation of a coordinate covalent bond

Once a coordinate covalent bond has formed, there is no difference between it and a normal covalent bond where one electron is donated by each atom in the bond.

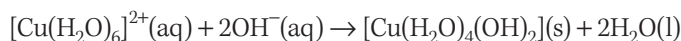
Examples of common ligands are water ( $\text{H}_2\text{O}$ ), ammonia ( $\text{NH}_3$ ), chloride ion ( $\text{Cl}^-$ ) and hydroxide ion ( $\text{OH}^-$ ). The coordinate bond is formed when the empty orbitals of the metal cation accepts a lone pair of electrons from each ligand.

When copper(II) salts are dissolved in water, they generally produce a blue solution and form a complex, hexaaquacopper(II) ( $[\text{Cu}(\text{H}_2\text{O})_6]^{2+}$ ) with water, as shown in Figure 14.8. The convention when writing the formula of complexes is to use square brackets to show the charge over the whole complex.

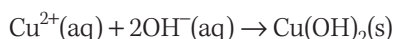


**FIGURE 14.8** Hexaaquacopper(II)

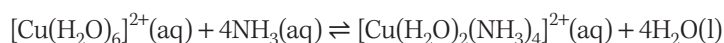
When an aqueous solution of sodium hydroxide is added to the copper(II) solution a pale blue precipitate is formed. The reaction involves two of the  $\text{OH}^-$  ions replacing two water molecules and the formation of a neutral compound. The addition of more  $\text{NaOH}$  has no significant effect on the compound:



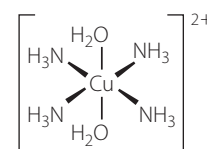
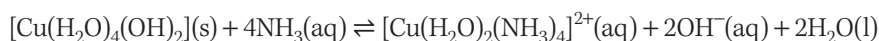
This is usually written more simply as:



The addition of ammonia solution to an aqueous copper(II) solution results in the formation of an amine complex due to the replacement of water ligands with  $\text{NH}_3$ , as shown in Figure 14.9. The resulting solution has a deep blue colour:

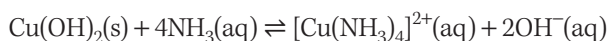


The addition of ammonia solution to the hydroxide precipitate discussed previously causes the precipitate to dissolve because the  $\text{NH}_3$  replaces the hydroxide ion ligands, resulting in the complex shown in Figure 14.9:

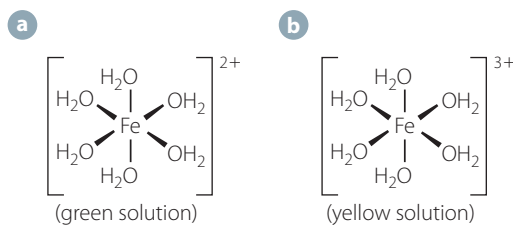


**FIGURE 14.9** Diaquatetraamminecopper(II)

Written more simply:



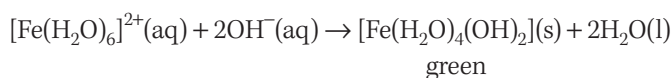
Iron complexes similar to that of copper also form in aqueous solution. When iron(II) salts are dissolved in water they produce a pale green solution due to the presence of hexaaquairon(II),  $[\text{Fe}(\text{H}_2\text{O})_6]^{2+}$ , while iron(III) salts produce a yellow solution due to hexaaquairon(III),  $[\text{Fe}(\text{H}_2\text{O})_6]^{3+}$ . These are shown in Figure 14.10.



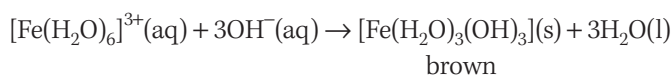
**FIGURE 14.10** **a** Hexaaquairon(II); **b** hexaaquairon(III)

The addition of hydroxide ions to either of these solutions results in the formation of complexes in which the  $\text{OH}^-$  ion has replaced water molecules to produce hydrated hydroxide precipitates similar to that of copper.

For  $\text{Fe}^{2+}$ , the reaction is:

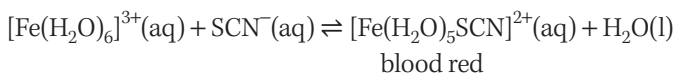


For  $\text{Fe}^{3+}$ , the reaction is:

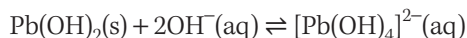


These equations are usually written in a simplified form that does not include the water ligands. Addition of excess  $\text{OH}^-$  or  $\text{NH}_3$  does not affect the precipitates formed.

As previously mentioned, the addition of  $\text{SCN}^-$  to a solution of iron(III) leads to the formation of  $\text{FeSCN}^{2+}$ . This is a complex ion formed when  $\text{SCN}^-$  replaces a water molecule.



Lead(II) hydroxide precipitate dissolves in the presence of excess hydroxide to form a complex ion. Written simply:



Although silver is not a transition metal it does form a complex ion with ammonia ( $\text{NH}_3$ ), the cyanide ion ( $\text{CN}^-$ ) and the thiosulfate ion ( $\text{S}_2\text{O}_3^{2-}$ ).

For example, solid silver chloride will dissolve in an ammonia solution to produce the linear complex ion  $[\text{Ag}(\text{NH}_3)_2]^+$  according to the reaction:



**Precipitates and complexes**  
Learn more about reactions of transition metals.

- Energy is emitted when electrons move from an excited state to the ground state. Each element has a unique set of energy levels.
- Flame tests can be used to identify elements that emit light energy in the visible region of the spectrum.
- Complexation reactions are ones in which a complex ion or compound is formed.
- A complex ion is one in which a central metal ion is attached to a number of small molecules or ions called ligands.

- 1 Explain 'ground state' and 'excited state' in reference to electrons in an atom. Use a diagram in your answer.
- 2 Explain why all atoms of sodium will emit the same set of wavelengths of light when heated.
- 3 A sample of copper(II) nitrate is compared to a sample of barium nitrate during a flame test experiment. Explain why they emit light of different colours.
- 4
  - a Explain why the presence of sparingly soluble salts may not be detected when using precipitation reactions.
  - b Suggest how the presence of these salts could be detected.
- 5
  - a A solution was thought to contain either barium chloride or calcium chloride. Samples of the solution gave a white precipitate with  $\text{Na}_2\text{SO}_4$  and a pale green flame colour. Which ions are present? Explain.
  - b A solution was thought to contain either lead nitrate or calcium nitrate. Describe which tests could be carried out to correctly identify the substance.
- 6 It has been suggested that once a cation has been identified, a confirmation test should also be conducted.
  - a Explain why it is a good idea to conduct a confirmation test.
  - b Describe a confirmation test for the presence of the following cations and the expected result for the presence of that cation.
    - i  $\text{Ag}^+$
    - ii  $\text{Fe}^{3+}$
    - iii  $\text{Ba}^{2+}$
- 7 Define the following terms, giving an example.
  - a Complex ion
  - b Ligand
- 8
  - a Explain what information is given by the formula  $[\text{Cu}(\text{H}_2\text{O})_4(\text{OH})_2]$ .
  - b Draw a diagram to show the structure of the compound.
- 9 Silver chloride dissolves in ammonia solution. Explain why this occurs, using equations.
- 10 A student was given four solutions and told each contained one of the following cations:  $\text{Pb}^{2+}$ ,  $\text{Cu}^{2+}$ ,  $\text{Ba}^{2+}$ ,  $\text{Ca}^{2+}$ ,  $\text{Fe}^{2+}$  or  $\text{Fe}^{3+}$ . The results of a series of tests that were conducted are given in the following table, where 'NP' stands for no precipitate and 'ppt' stands for precipitate.

REAGENT ADDED	A	B	C	D
KI	Yellow ppt	NP	NP	NP
$\text{H}_2\text{SO}_4$	ppt	NP	ppt	ppt
NaOH	ppt	Brown ppt	NP	ppt

Use the given results to identify possible cations for A–D. If there is not enough information, suggest other possible tests and their expected results that could be used to identify any still unknown solutions.

## 14.4 Identifying anions in solution

In the previous section, you learnt about tests that could be used to identify cations. In this section, you will focus on identifying the following anions.

- Chloride ( $\text{Cl}^-$ ), bromide ( $\text{Br}^-$ ), iodide ( $\text{I}^-$ ), hydroxide ( $\text{OH}^-$ ), acetate ( $\text{CH}_3\text{COO}^-$ ), carbonate ( $\text{CO}_3^{2-}$ ), sulfate ( $\text{SO}_4^{2-}$ ) and phosphate ( $\text{PO}_4^{3-}$ )

Precipitation reactions are usually used to identify anions. Common tests for the anions listed are given in Table 14.4 (page 420).



**TABLE 14.4 Tests for anions**

ANION	TEST
Carbonate ( $\text{CO}_3^{2-}$ )	1 Solution has a pH between 8 and 11 (pH paper suffices). 2 Addition of dilute $\text{HNO}_3$ produces bubbles of colourless gas ( $\text{CO}_2$ ). <sup>a</sup> Gas turns limewater milky.
Hydroxide ( $\text{OH}^-$ )	1 pH > 7, turns red litmus blue. 2 Addition of $\text{NH}_4^+$ followed by gently heating will produce ammonia gas.
Chloride ( $\text{Cl}^-$ )	1 Addition of $\text{AgNO}_3$ to an acidified sample produces a white precipitate, <sup>b</sup> which dissolves in dilute ammonia solution and darkens in sunlight.
Bromide ( $\text{Br}^-$ )	1 Addition of $\text{AgNO}_3$ to an acidified sample produces a pale cream precipitate that dissolves in concentrated ammonia solution; solution darkens slowly in sunlight.
Iodide ( $\text{I}^-$ )	1 Addition of $\text{AgNO}_3$ to an acidified sample produces a pale yellow precipitate that does not dissolve in ammonia solution; solution not affected by sunlight. 2 Addition of $\text{Pb}(\text{NO}_3)_2$ produces a yellow precipitate.
Sulfate ( $\text{SO}_4^{2-}$ )	1 Addition of $\text{Ba}(\text{NO}_3)_2$ to an acidified sample of the solution produces a thick white precipitate. 2 Acidification and addition of $\text{Pb}(\text{NO}_3)_2$ produces a white precipitate.
Phosphate ( $\text{PO}_4^{3-}$ )	1 Addition of ammonia followed by $\text{Ba}(\text{NO}_3)_2$ produces a white precipitate. 2 Addition of $\text{Mg}^{2+}$ in an ammonia/ammonium nitrate buffer produces a white precipitate, $\text{Mg}(\text{NH}_4)\text{PO}_4$ . 3 Acidification with $\text{HNO}_3$ followed by addition of ammonium molybdate solution ( $(\text{NH}_4)_2\text{MoO}_4$ ) produces a yellow precipitate; warming the mixture for a few minutes may be necessary.
Acetate ( $\text{CH}_3\text{COO}^-$ )	1 Does not precipitate with any cations except concentrated $\text{Ag}^+$ . 2 An aqueous solution may have a vinegar smell. 3 Addition of neutral $\text{FeCl}_3$ produces a reddish brown solution; filter, add dilute HCl and colour disappears.

<sup>a</sup> Any strong acid would do, but for analysing mixtures you do not want to introduce any  $\text{Cl}^-$  or  $\text{SO}_4^{2-}$ .

<sup>b</sup> In non-acidic solutions, silver nitrate also produces precipitates with carbonate and phosphate (and with sulfate at all pH values if sulfate concentration is moderately high), so this test alone does not prove the presence of chloride: it is also necessary to prove the absence of sulfate.

Many of the tests use metals ions that form precipitates with a number of the anions that need to be identified. The formation of some of the precipitates is pH dependent and this is why many of the tests above specify the addition of an acid or alkali as part of the test. This is summarised in Table 14.5.

**TABLE 14.5 Precipitates formed between cations and anions**

CATION <sup>a</sup>	ANION							
	$\text{OH}^-$	$\text{Cl}^-$	$\text{Br}^-$	$\text{I}^-$	$\text{SO}_4^{2-}$	$\text{CO}_3^{2-}$ IN ALKALINE SOLUTION <sup>b</sup>	$\text{PO}_4^{3-}$	
							SOLUTION pH < 2	SOLUTION pH > 6
$\text{Ba}^{2+}$	No	No	No	No	Yes	Yes	No	Yes
$\text{Pb}^{2+}$	Yes	Yes <sup>c</sup>	Yes	Yes	Yes	Yes	No	Yes
$\text{Ag}^+$	Yes <sup>d</sup>	Yes <sup>e</sup>	Yes <sup>f</sup>	Yes <sup>g</sup>	Yes <sup>c</sup>	Yes	No	Yes
$\text{Cu}^{2+}$	Yes	No	No	No	No	Yes	No	Yes

<sup>a</sup> In acidic or alkaline solution.

<sup>b</sup> Cannot have carbonate in acid solution: it decomposes to  $\text{CO}_2(\text{g})$ .

<sup>c</sup> Provided concentration of  $\text{Cl}^-$  or  $\text{SO}_4^{2-}$  is not too low, say > 0.05 mol L<sup>-1</sup>.

<sup>d</sup> Precipitate is brown  $\text{Ag}_2\text{O}$ .

<sup>e</sup> Precipitate is white and dissolves in dilute ammonia solution.

<sup>f</sup> Precipitate is cream and dissolves in concentrated ammonia solution.

<sup>g</sup> Precipitate is yellow and does not dissolve in concentrated ammonia solution.



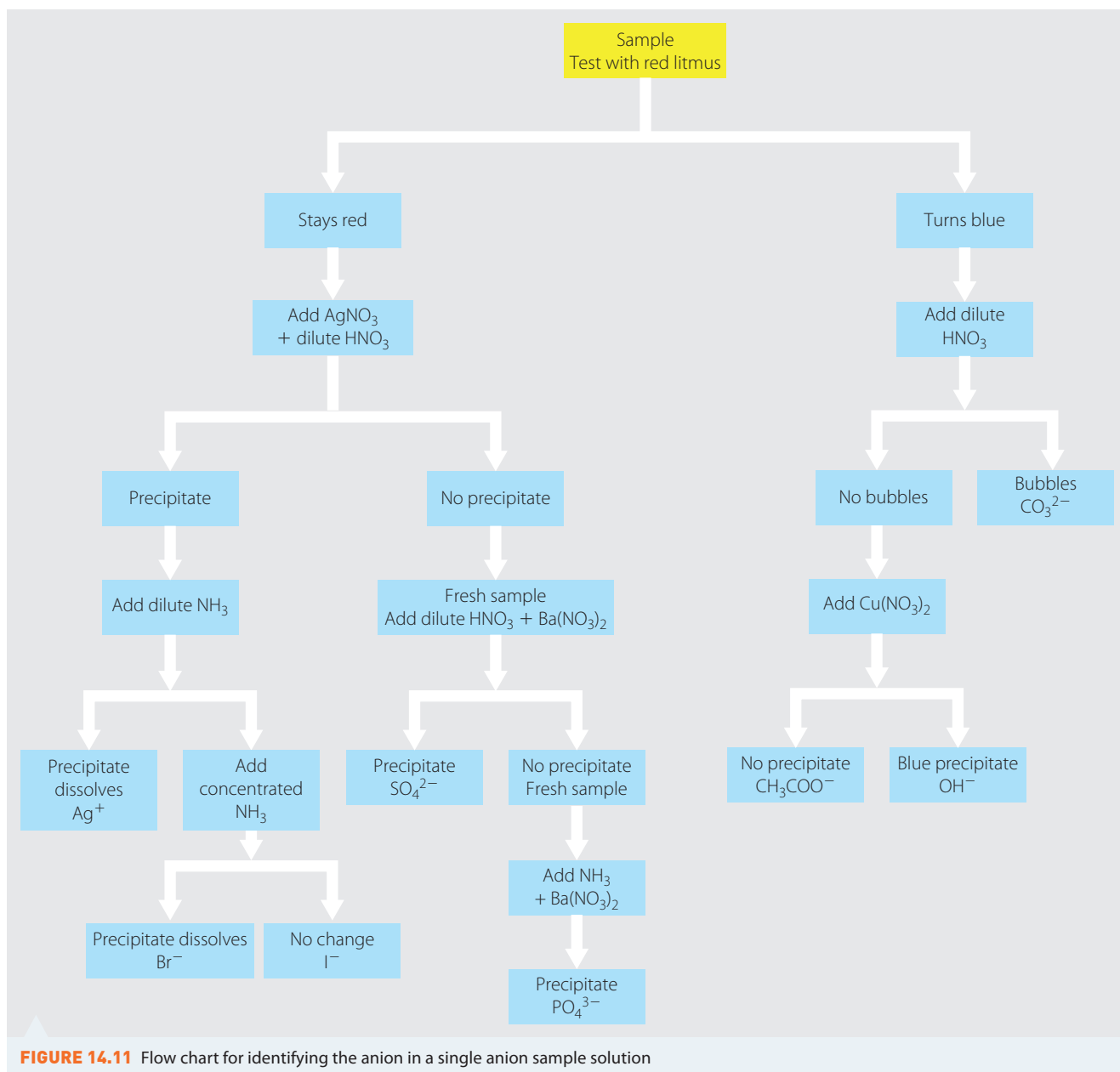
#### Tests for anions

View the videos to see tests for various anions.

As can be seen in the table above there are many tests, and combinations of tests, that can be conducted to identify the anion present when a sample contains only one anion.

The colour of the precipitates may be only slightly different so using colour is not specific enough to identify the anion. While the halide precipitates of silver are slightly different colours it is often difficult to distinguish between AgBr and AgI, and thus a further confirmatory test should be conducted.

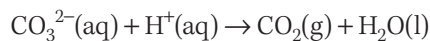
Figure 14.11 gives one procedure for identifying the anion in solution that contains only one anion.



## Testing for carbonate, hydroxide and acetate

As was discussed in chapter 5, both carbonates and hydroxides are alkaline. Therefore, the use of an indicator such as litmus paper will identify the presence of these ions in solution. As discussed in chapter 6, the acetate ion is the conjugate base of acetic acid, which is a weak acid so it too will be alkaline.

While the hydroxide ion will neutralise an acid to produce a salt and water, carbonates will produce a salt and water as well as carbon dioxide gas, which will bubble out of the solution. Therefore, a simple test to distinguish between these alkaline ions is a simple acid–base reaction:



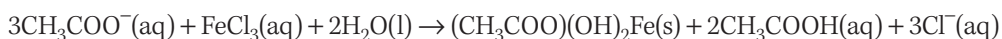
The acetate ion does not form precipitates with metal ions at dilute concentrations so its presence tends to be detected by the absence of results. However, it may be detected by the presence of a vinegar smell if the concentration is high enough.

A two-part confirmation test can be conducted using a neutral iron(III) chloride solution. Addition of neutral iron(III) chloride solution to the sample should result in a reddish coloured filtrate due to the formation of  $(\text{CH}_3\text{COO})_3\text{Fe}$ . A precipitate may also be produced with the chloride ion depending on the cation present in the acetate solution. If a precipitate forms, it must be separated from the solution by filtering the mixture and further testing the filtrate.

The filtrate is divided into two portions to allow for both parts of the confirmation test to be conducted.

- 1 Add water to one portion and heat strongly. This should result in the formation of a reddish brown precipitate due to the formation of  $(\text{CH}_3\text{COO})(\text{OH})_2\text{Fe}$ .

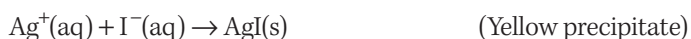
The equation for this reaction is:



- 2 Addition of dilute HCl to the other portion should result in the disappearance of the reddish colour.

### Testing for halides ( $\text{Cl}^-$ , $\text{Br}^-$ and $\text{I}^-$ )

Silver nitrate is used to identify the presence of the halide ions  $\text{Cl}^-$ ,  $\text{Br}^-$  and  $\text{I}^-$ . The solution is acidified by adding dilute nitric acid to prevent the precipitation of other non-halide ions such as carbonate. All three of these halides form a precipitate with  $\text{Ag}^+$ ; however,  $\text{F}^-$  does not. The net ionic equations for these reactions are:



While the halide precipitates of silver are slightly different colours, it is often difficult to distinguish between them, especially AgBr and AgI. A further confirmatory test using dilute or concentrated ammonia solution should be conducted. The solubility of the silver halides in ammonia decreases in the order:  $\text{AgCl} > \text{AgBr} > \text{AgI}$ .

As mentioned in the previous section, when  $\text{NH}_3$  is added to insoluble AgCl, the ammonia binds to the  $\text{Ag}^+$  ion forming the complex diamine silver,  $[\text{Ag}(\text{NH}_3)_2]^+$  and producing a colourless solution:



Silver bromide only dissolves in a concentrated ammonia solution to form the same complex ion of silver:

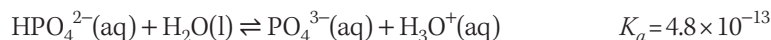
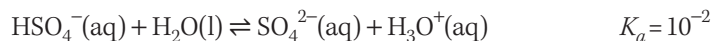


Silver iodide does not dissolve in either dilute or concentrated ammonia solution.

## Testing for sulfate and phosphate

As can be seen in Table 14.5 (page 420),  $\text{Ba}^{2+}$  will form precipitates with both  $\text{SO}_4^{2-}$  and  $\text{PO}_4^{3-}$  under specific conditions, while it will not form a precipitate with the acetate ion. However, when the solution has a  $\text{pH} < 2$ , phosphate ions will not precipitate with  $\text{Ba}^{2+}$ .

This is because in an acidic solution there is an equilibrium between the conjugate acid and the ion, as shown in the equations below:



As can be seen by the  $K_a$  values in the equations above,  $\text{HSO}_4^-$  is a much stronger acid than  $\text{HPO}_4^{2-}$  so the concentration of the  $\text{SO}_4^{2-}$  ions is greater than  $\text{PO}_4^{3-}$  in solution. This means that the concentration of  $\text{SO}_4^{2-}$  is high enough to form the precipitate  $\text{Ba}_2\text{SO}_4$ , while there is insufficient  $\text{PO}_4^{3-}$  to produce a precipitate.

However, the addition of ammonia to increase the pH to 10–11 removes  $\text{H}_3\text{O}^+$  ions, shifting the equilibrium to the right, and producing a high enough concentration of  $\text{PO}_4^{3-}$  to produce the precipitate  $\text{Ba}_3(\text{PO}_4)_2$ .

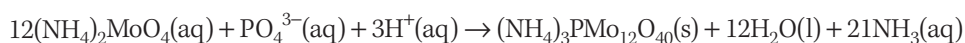
## Other tests for phosphate

There are two other tests that can be used to determine the presence of phosphate. These are both listed in Table 14.4 (page 420). The advantage of these tests is that they are specific to phosphate and so the presence of other anions in the sample will not affect these tests.

### 1 Ammonium molybdate test

Addition of concentrated nitric acid and ammonium molybdate solution ( $(\text{NH}_4)_2\text{MoO}_4$ ) to the sample should result in the production of a yellow precipitate, ammonium phosphate molybdate, if the phosphate ion is present. The solution may need to be warmed for a few minutes if a precipitate does not immediately appear.

The equation for this reaction is:



The ammonium phosphate molybdate is a complex and can be represented as  $(\text{NH}_4)_3\text{PO}_4 \cdot 12\text{MoO}_3$ .

### 2 Magnesium ammonia test

Addition of  $\text{Mg}^{2+}$  in an ammonia/ammonium nitrate buffer to the sample should result in the production of a white precipitate  $\text{Mg}(\text{NH}_4)\text{PO}_4$ . It may be necessary to allow the sample to stand for a while.

The equation for this reaction is:



Identifying anions

# INVESTIGATION 14.3

## Tests for anions

### INTRODUCTION

In the previous investigation, you conducted a series of tests to identify specified cations. In this investigation you will devise and conduct a series of tests to identify the following anions: chloride ( $\text{Cl}^-$ ), bromide ( $\text{Br}^-$ ), iodide ( $\text{I}^-$ ), hydroxide ( $\text{OH}^-$ ), acetate ( $\text{CH}_3\text{COO}^-$ ), carbonate ( $\text{CO}_3^{2-}$ ), sulfate ( $\text{SO}_4^{2-}$ ) and phosphate ( $\text{PO}_4^{3-}$ ). You will then obtain a sample containing an unknown anion and try to identify it.

### AIM

Write an aim for this investigation.

### HYPOTHESIS

Write a hypothesis for this investigation.

### HINTS

- 1 The information provided in Table 14.4, Table 14.5 and Figure 14.11 will provide information on a possible sequence and tests to conduct.
- 2 Anion and test solutions need only be  $0.1 \text{ mol L}^{-1}$  unless concentrated is necessary. Only small quantities (1–2 mL) need to be used.
- 3 Anion solutions should not contain cations, which will precipitate with any of the other anions being tested.
- 4 Concentrated acids and ammonia solution are dangerous so take appropriate safety precautions including the use of a fume cupboard for concentrated ammonia.
- 5 Some metal salts are toxic; therefore, wear appropriate personal protective clothing and ensure correct disposal.

### MATERIALS

Construct a materials list for your investigation. Make sure you identify quantities and concentrations needed. Complete a risk assessment for your investigation.



WHAT ARE THE RISKS IN DOING THIS INVESTIGATION?	HOW CAN YOU MANAGE THESE RISKS TO STAY SAFE?

### METHOD

Devise a method to test the solutions. Use Table 14.4, Table 14.5 and Figure 14.11 for ideas. Ensure that you consider if confirmation tests may be needed.

### RESULTS

Record your results in a carefully planned table.

### DISCUSSION

Discuss your results with particular attention to:

- ease or difficulty in identifying each anion
- the need for confirmation testing
- possibility of contamination
- accuracy in identifying the unknown sample.

### CONCLUSION

With reference to the results obtained, write a conclusion based on the aim of this investigation.

- Precipitation reactions are usually used to identify anions.
- An indicator such as litmus paper will identify the presence of carbonate, hydroxide and acetate ions in solution.
- Acetate ion does not form precipitates with metal ions at dilute concentrations so its presence tends to be detected by absence of results.
- Silver nitrate is used to identify the presence of the halide ions  $\text{Cl}^-$ ,  $\text{Br}^-$  and  $\text{I}^-$ .

#### CHECK YOUR UNDERSTANDING

14.4

- 1 Explain whether or not using  $\text{K}^+$  to test for anions would be effective.
- 2 A solution was known to contain either sodium carbonate or sodium chloride. Samples of the solution gave bubbles of gas with  $\text{HNO}_3$  but no precipitate with  $\text{Ba}(\text{NO}_3)_2$ . Which anion is present? Explain.
- 3 **a** A solution was known to contain either sodium hydroxide or sodium acetate. A student proposed to test the solution with litmus paper to determine which anion was present. Explain whether this test could be used to distinguish between these anions and why/why not.
  - b** Describe another test that could be used to distinguish between these two anions.
- 4 **a** Explain why precipitate colour should not be used to identify the halide present in silver halide precipitates.
  - b** Describe a test that can be used to distinguish between silver halide precipitates and why it works.
- 5 Explain, using equations, why the phosphate ion does not precipitate with  $\text{Ba}^{2+}$  in acidic solutions but does precipitate with  $\text{Ba}^{2+}$  in alkaline solutions.

## 14.5 Quantitative analysis of ions

In the previous sections, the identification of specific cations and anions was discussed. However, chemists may also need to know how much of these species is present. This section will focus on techniques that are used to determine concentrations of particular species.

### Precipitation titrations

In chapter 7, you learnt about using titrations to determine quantities of specific species. Some of the titrations involved the use of acid–base reactions, while others involved the use of redox reactions. In this section, precipitation titrations will be used to determine the quantity of a particular ion present in a solution. Precipitation titrations use a precipitation reaction to determine the amount of a species present.

The technique and equipment used in precipitation titrations is similar to that used in other types of titration. Using either a direct titration method or a back titration method involving a precipitation reaction, the amount of a particular cation or anion present can be determined. Most precipitation titrations for anions involve the use of the silver cation ( $\text{Ag}^+$ ), usually from a silver nitrate solution, to precipitate silver salts of the anion being investigated.

One of the problems when conducting precipitation titrations is identifying the end point, since it is difficult to visually determine when there is no more precipitate being deposited.

There are three main methods that can be used to determine the end point of a precipitation titration. All three methods involve the use of silver nitrate solution to produce precipitates.

### Mohr's method

This method is used for determination of chlorides, bromides and cyanides by direct titration with a known concentration of silver nitrate. In this method, chromate ions are used as the indicator. At the end point, when all the halide ions have precipitated, additional silver ions react with the chromate indicator to form a red-brown precipitate of silver chromate ( $\text{Ag}_2\text{CrO}_4$ ). The instant a permanent colour change is detected the titration is finished.

To revise direct titrations, refer to section 7.3, p. 198.  
To revise back titrations, refer to section 7.4, p. 203.

Using this method, errors occur because the end point is identified by the addition of more titrant to achieve the colour change beyond the end point. This can be addressed by conducting a blank titration to determine the extra titrant needed to achieve a change in colour.

In the blank titration, the silver nitrate solution is titrated against a solution that contains the indicator, and no halide ion, until the indicator changes colour. For example, the blank solution may be a solution of calcium carbonate and chromate indicator. The calcium carbonate imitates the white silver chloride precipitate. The volume of silver nitrate obtained in the blank titration is equivalent to the excess of silver nitrate needed to obtain the indicator colour change following equivalence point. This volume is subtracted from the titrant volume of silver nitrate prior to calculating the halide ion concentration.

A constant amount of indicator must also be used in each titration. If too little indicator is used, more  $\text{Ag}^+$  will be needed to produce the colour, while if too much is used the colour change may be difficult to see.

The pH of sample solutions being tested needs to be carefully controlled to remain between 6 and 9. This is because:

- a higher pH will result in the formation of a silver hydroxide precipitate
- at a lower pH the chromate ion is protonated to form chromic acid, making the concentration of the chromate ion too low to produce the precipitate at equivalence point.

### WORKED EXAMPLE (14.1)



A titration was conducted using Mohr's method using a chromate ion indicator to determine the concentration of  $\text{Cl}^-$  in a solution. A blank titration required 0.50 mL of the  $1.00 \text{ mol L}^{-1}$  silver nitrate titrant to achieve a colour change. 25 mL of the unknown solution required 33.70 mL of the titrant to reach end point. Calculate the  $\text{Cl}^-$  concentration of the unknown sample.

ANSWER	LOGIC
Volume $\text{AgNO}_3$ used = 33.70 mL Volume of blank = 0.50 mL Volume to reach end point = $33.70 - 0.50 = 33.20 \text{ mL}$	<ul style="list-style-type: none"> <li>▪ Extract data from question to determine titration volume.</li> </ul>
$n = cV$ $n(\text{AgNO}_3) = c \times V = 1.00 \times 0.0332 = 0.0332 \text{ mol}$ $n(\text{Ag}^+) = n(\text{AgNO}_3) = 0.0332 \text{ mol}$	<ul style="list-style-type: none"> <li>▪ Calculate moles of <math>\text{Ag}^+</math>.</li> </ul>
$\text{Ag}^+(\text{aq}) + \text{Cl}^-(\text{aq}) \rightarrow \text{AgCl}(\text{s})$ $n(\text{Ag}^+) = n(\text{Cl}^-) = 0.0332 \text{ mol}$	<ul style="list-style-type: none"> <li>▪ Calculate moles of <math>\text{Cl}^-</math>.</li> </ul>
$c = \frac{n}{V}$ $V = 25 \text{ mL}$ $[\text{Cl}^-] = \frac{0.0332}{0.025} = 1.33 \text{ mol L}^{-1}$	<ul style="list-style-type: none"> <li>▪ Calculate concentration of <math>\text{Cl}^-</math>.</li> </ul>

#### TRY THESE YOURSELF

- 1 50 mL of a bromide ion solution was titrated with a  $1.6 \text{ mol L}^{-1}$  silver nitrate solution to end point using a chromate ion indicator. An average titre of 12.6 mL was required. A blank titration was conducted with the same silver nitrate solution and indicator and required 0.20 mL to obtain indicator colour change. Calculate the concentration of bromide ions in the unknown sample.
- 2 The soluble salt content of a brand of potato chips was analysed. 3.06 g of chips required 20.6 mL of a  $0.12 \text{ mol L}^{-1}$  silver nitrate solution to achieve end point. A blank titration required 0.50 mL to achieve indicator colour change. Calculate the %w/w of NaCl.



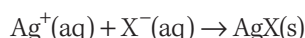
## Volhard's method

Volhard's method uses a back titration of an acidic solution to determine the quantity of particular anions in a solution. It is also a good method for the analysis of  $\text{Ag}^+$  by direct titration.

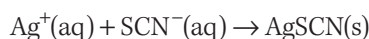
You should recall that back titrations were discussed in chapter 7. It can be used for determination of halides ( $\text{Cl}^-$ ,  $\text{Br}^-$ ,  $\text{I}^-$ ), phosphate, chromate, sulfide, carbonate and cyanide. In this method, a known excess amount of silver nitrate is added to the sample to be tested, resulting in precipitation of all the ions being investigated.

The excess silver nitrate is then titrated against a standard solution of potassium thiocyanate producing  $\text{AgSCN}(s)$ . To detect the end point,  $\text{Fe}^{3+}$  ions are added to the silver nitrate solution. Once all the excess  $\text{Ag}^+$  ions have reacted, the next drop of thiocyanate reacts with the  $\text{Fe}^{3+}$  ions to produce the distinctive blood red colour of  $\text{Fe}(\text{SCN})^{2+}$  indicating the end point has been reached.

There are two reactions that occur since this is a back titration. The first reaction is precipitation of the anion  $\text{X}^-$  with excess  $\text{Ag}^+$ :

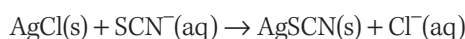


The second reaction is the titration of the excess  $\text{Ag}^+$  with  $\text{SCN}^-$ :



Errors can occur when the precipitate being investigated is more soluble than the end point precipitant ( $\text{AgSCN}$ ).

For example:  $\text{AgCl}$  is more soluble than  $\text{AgSCN}$ . This means the  $\text{AgCl}$  precipitate present in the solution will dissolve as  $\text{SCN}^-$  is added, as shown in the equation:



This will result in a higher concentration of  $\text{Ag}^+$  being measured, and therefore, a lower concentration of  $\text{Cl}^-$  than is actually present. (Remember this is a back titration, so the excess  $\text{Ag}^+$  is being measured using  $\text{SCN}^-$ ).

A comparison of the  $K_{sp}$  values of the different silver precipitates, shown in Table 14.6, will indicate if the precipitate is more or less soluble than  $\text{AgSCN}(s)$ .

If  $K_{sp}$  of the initial precipitate  $>$   $K_{sp}$  of  $\text{AgSCN}$ , the precipitate will dissolve, so it needs to be filtered from the solution before titration with  $\text{SCN}^-$ .

If  $K_{sp}$  of the initial precipitate  $<$   $K_{sp}$  of  $\text{AgSCN}$ , the precipitate will not dissolve, so it does not need to be removed.

Solubility of precipitates and  $K_{sp}$  were discussed in chapter 4, p. 102. You may wish to revise these.

**TABLE 14.6**  $K_{sp}$  values of some silver salts

PRECIPITATE	$K_{sp}$
$\text{AgSCN}$ (end point precipitate)	$1.03 \times 10^{-12}$
$\text{AgBr}$	$5.35 \times 10^{-13}$
$\text{Ag}_2\text{CO}_3$	$8.46 \times 10^{-12}$
$\text{AgCl}$	$1.77 \times 10^{-10}$
$\text{Ag}_2\text{CrO}_4$	$1.12 \times 10^{-12}$
$\text{AgCN}$	$5.97 \times 10^{-17}$
$\text{AgI}$	$8.52 \times 10^{-17}$
$\text{Ag}_3\text{PO}_4$	$8.89 \times 10^{-17}$
$\text{Ag}_2\text{SO}_4$	$1.20 \times 10^{-5}$
$\text{Ag}_2\text{S}$	$8 \times 10^{-51}$

Transfer errors can also occur when removing the precipitate prior to titration. The pH of the solution must be low to prevent precipitation of  $\text{Fe}^{3+}$  as  $\text{Fe}(\text{OH})_3$ .

## WORKED EXAMPLE (14.2)



A student wanted to determine the concentration of the iodide ion ( $I^-$ ) present in a particular solution. The student added 50.0 mL of  $0.890 \text{ mol L}^{-1}$  silver nitrate to 25 mL of the solution. The excess silver nitrate was titrated against 42.3 mL of  $0.881 \text{ mol L}^{-1}$  sodium thiocyanate solution.  $Fe^{3+}$  was used as an indicator for the end point of the titration. Calculate the concentration of iodide ion present in the sample.

ANSWER	LOGIC
$Ag^+(aq) + I^-(aq) \rightarrow AgI(s)$ $Ag^+(aq) + SCN^-(aq) \rightarrow AgSCN(aq)$	<ul style="list-style-type: none"> <li>Write balanced chemical equations for all reactions.</li> </ul>
$n_{AgNO_3} = c_{AgNO_3} \times V_{AgNO_3} = 0.890 \times 0.0500 = 0.0445 \text{ mol}$ $n_{AgNO_3} = n_{Ag^+} = 0.0445 \text{ mol}$	<ul style="list-style-type: none"> <li>Calculate the original number of moles of <math>Ag^+</math> that was added to the sample.</li> </ul>
$n_{SCN^-} = c_{SCN^-} \times V_{SCN^-} = 0.881 \times 0.0423 = 0.0373 \text{ mol}$ $n_{Ag^+} = n_{SCN^-} = 0.0373 \text{ mol}$	<ul style="list-style-type: none"> <li>Calculate the number of moles of <math>Ag^+</math> that reacted with <math>SCN^-</math> (this is the excess <math>Ag^+</math>)</li> </ul>
Number of moles of $Ag^+$ reacted with $I^-$ = Number of moles of $Ag^+$ added to the sample – number of moles of $Ag^+$ reacted with $SCN^-$ $n_{Ag^+ \text{ reacted with } I^-} = 0.0445 - 0.0373 = 0.00720 \text{ mol}$	<ul style="list-style-type: none"> <li>Calculate the number of moles of <math>Ag^+</math> that reacted with the <math>I^-</math>.</li> </ul>
$n_{Ag^+} = n_{I^-} = 0.00720 \text{ mol}$ $c = \frac{n}{V} = \frac{0.00720}{0.025} = 0.288 \text{ mol L}^{-1}$	<ul style="list-style-type: none"> <li>Calculate the concentration of <math>I^-</math> present in the sample.</li> </ul>
Concentration of iodide ion = $0.288 \text{ mol L}^{-1}$	<ul style="list-style-type: none"> <li>Express answer in correct form.</li> </ul>

### TRY THIS YOURSELF

Calculate the concentration of salt in a brand of soy sauce that is diluted by a factor of 10. 25 mL of the diluted sample was mixed with 25 mL of a  $0.12 \text{ mol L}^{-1}$  silver nitrate solution. The sample was filtered to remove the precipitate. 25 mL of the filtrate required 12.3 mL of  $0.11 \text{ mol L}^{-1}$  thiocyanate solution to reach end point.

## Fajan's method

Fajan's method involves a direct titration with the end point being determined by a colour change using an **absorption indicator**. The indicator absorbs onto the surface of the precipitate at the end point and changes colour (Table 14.7). Absorption indicators function in an entirely different manner to the chemical indicators used in other titrations discussed. The action of the indicator is not required in this course so it will not be discussed here.

In Mohr's and Volhard's methods discussed above, a specific indicator was used for each method irrespective of the species being analysed. In Fajan's method, the indicator used depends on the different species being analysed. Because the indicators are pH dependent, the pH must be strictly controlled during the titration.

**TABLE 14.7** Some common indicators used in Fajan's method

INDICATOR	COLOUR CHANGE	USE
Fluorescein	Yellow-green to pink	All halides, pH 7–10
Eosin	Pink to red-violet	Sample must not contain $Cl^-$ , pH > 1
Dichlorofluorescein	Orange to blue	$I^-$ only, pH 4–7
Diiododimethylfluorescein	Yellow-green to red	$Cl^-$ and $Br^-$ , pH 4–7

Source: [http://cffet.net/ptt/6\\_Ppt\\_titr.pdf](http://cffet.net/ptt/6_Ppt_titr.pdf)



### Absorption indicators

The link provides information on how absorption indicators work.

Fajan's method cannot be used:

- ▶ if the species being analysed is present in only low concentrations, since there will not be enough precipitate for the indicator to change colour; or
- ▶ if there are significant quantities of non-reacting ions, since the indicator may coagulate with these ions and not adsorb onto the precipitate and so a colour change may not be observed.

The three methods are summarised in Table 14.8.

**TABLE 14.8** Summaries of the three different methods

METHOD	TITRATION TYPE	INDICATOR AND CHANGE	SPECIES ANALYSED	LIMITATIONS
Mohr	Direct titration	Yellow chromate ion to red-brown $\text{Ag}_2\text{CrO}_4(\text{s})$	$\text{Cl}^-$ , $\text{Br}^-$ , $\text{CN}^-$	Needs pH 6–9 Not suitable for $\text{I}^-$ Blank titration needed
Volhard	Direct titration for $\text{Ag}^+$ Back titration for anions	Colourless $\text{SCN}^-$ to blood red $\text{Fe}(\text{SCN})^{2+}$	$\text{Cl}^-$ , $\text{Br}^-$ , $\text{I}^-$ , $\text{CN}^-$ , $\text{PO}_4^{3-}$ , $\text{Cr}_2\text{O}_7^{2-}$ , $\text{S}^{2-}$ , $\text{CO}_3^{2-}$	Need low pH Precipitate may need to be removed before titration Possible transfer errors
Fajan	Direct titration	Needs specific indicator for particular species (Refer to Table 14.7)	$\text{Cl}^-$ , $\text{Br}^-$ , $\text{I}^-$	Needs specific pH for indicator Cannot be used for low concentrations of ions Cannot be used if high levels of other ions present

In the following investigation, you will use Volhard's method to determine the concentration of iodide ion in a given sample. An example of the calculations used in a back titration are shown in Worked example 14.2 above.

## INVESTIGATION 14.4

### Determination of iodide ion concentration by titration (Volhard's method)

#### INTRODUCTION

This titration uses Volhard's method to determine the concentration of iodide ions in solution. The silver iodide precipitate formed with addition of excess silver nitrate does not need to be removed before the titration proceeds since it is less soluble than the  $\text{AgSCN}$  precipitate formed at end point.

#### AIM

Write an aim for this investigation.

#### HYPOTHESIS

Write a hypothesis for this investigation.

#### MATERIALS

- 20 mL of  $1.0 \text{ mol L}^{-1}$  nitric acid
- 50 mL of  $0.1 \text{ mol L}^{-1}$  silver nitrate
- 5 mL saturated ferric ammonium sulfate ( $\text{NH}_4\text{Fe}(\text{SO}_4)_2$ ) solution
- 50 mL of  $0.1 \text{ mol L}^{-1}$  sodium iodide sample solution
- 100 mL of  $0.1 \text{ mol L}^{-1}$  standard sodium thiocyanate solution
- Distilled water
- Dropper
- 5 mL and 10 mL measuring cylinder



- » 3 × 250 mL conical flasks
- 50 mL burette
- Burette clamp and retort stand
- Filter funnel
- 2 × 10 mL pipette
- Pipette filler
- Safety glasses



WHAT ARE THE RISKS IN DOING THIS INVESTIGATION?	HOW CAN YOU MANAGE THESE RISKS TO STAY SAFE?
Nitric acid is corrosive.	Wear safety glasses and wash your hands at the end of the experiment.
Silver salts are poisonous. Silver nitrate will leave a brown stain on clothing and skin.	Avoid contact with skin and clothes. Wash hands thoroughly after use. Dispose of the chemicals as directed by your teacher.
Glassware could break and cut your hands.	Keep glassware away from the edge of the bench. When the pipette is not in use, leave the pipette filler on the pipette to prevent it rolling off the bench. If glassware does break, inform your teacher immediately.

What other risks are associated with this investigation? How can you manage these?

#### METHOD

- 1 Pipette 10 mL of the sample solution into a conical flask.
- 2 Pipette 10 mL of silver nitrate solution into the flask. Add 5 mL of nitric acid and 1 mL of ferric ammonium sulfate solution.
- 3 Repeat steps 1 and 2 until there are three flasks.
- 4 Fill the burette with 0.1 mol L<sup>-1</sup> sodium thiocyanate solution.
- 5 Record the initial reading on the burette.
- 6 Titrate the solution in the flask with the thiocyanate until a blood-red colour appears. Record the final volume reading on the burette.
- 7 Repeat steps 4–6 until three consistent readings have been obtained.

#### RESULTS

Record the results in a suitably formatted table.

#### ANALYSIS OF RESULTS

- 1 Determine the average volume of sodium thiocyanate.
- 2 Calculate the average number of moles of sodium thiocyanate.
- 3 Write a balanced equation for the reaction between silver ions and thiocyanate ions.
- 4 Calculate the number of moles of silver nitrate reacted with thiocyanate ions. (This is the excess silver nitrate.)
- 5 Calculate the number of moles of silver nitrate added to the flask.
- 6 Calculate the number of moles of silver nitrate that reacted with the iodide sample.
- 7 Calculate the moles of iodide ions in the sample.
- 8 Calculate the concentration of sodium iodide in the sample solution.

#### DISCUSSION

- 1 Compare your results with other members of the class and suggest reasons for any differences.
- 2 Identify any sources of error in this investigation and suggest ways to minimise them.

#### CONCLUSION

With reference to the data obtained and the results, write a conclusion.

## Gravimetric analysis

In the previous section, volumetric analysis with a precipitation titration was used to determine the concentration of specific ions present in a solution. **Gravimetric analysis** is another quantitative analytical technique; however, it uses mass rather than volume.

In all gravimetric analysis methods, the species required in the analysis must be separated from the rest of the mixture.

For example, gravimetric analysis is a common method of analysing the composition of fertilisers. The fertiliser is dissolved in water, and then chemicals are added to precipitate the substance to be analysed. The solid precipitate is filtered from the solution, dried, weighed and compared to the mass of the initial mass of the fertiliser. From this, a percentage composition of an element or compound can be determined. Alternatively the concentration of the ion can be calculated.

The determination of sulfate content in lawn fertilisers is done using gravimetric analysis. Sulfur is an important plant nutrient often found in fertilisers as ammonium sulfate. This chemical is suitable for use in alkaline soils since it helps to lower the alkalinity of the soil, promoting better plant growth.

### WORKED EXAMPLE (14.3)

10.0 g of fertiliser containing ammonium sulfate is dissolved, and barium chloride is added. The barium ions react with the sulfate ions to form solid barium sulfate. Neither the chloride nor the ammonium ions form a precipitate, so will stay in solution. The solid barium sulfate is extracted by filtration, dried and weighed. The mass of the barium sulfate precipitate is 8.25 g. Determine the percentage of sulfate in the fertiliser.

ANSWER	LOGIC
$\text{Ba}^{2+}(\text{aq}) + \text{SO}_4^{2-}(\text{aq}) \rightarrow \text{BaSO}_4(\text{s})$	<ul style="list-style-type: none"><li>Write a balanced chemical equation for the reaction.</li></ul>
$\begin{aligned} \text{Mass of BaSO}_4 &= 8.25 \text{ g} \\ \text{Mass of SO}_4^{2-} &= \frac{\text{formula mass of SO}_4^{2-} \times \text{mass BaSO}_4}{\text{formula mass BaSO}_4} \\ &= \frac{96.1 \times 8.25}{233.4} \\ &= 3.4 \text{ g} \end{aligned}$	<ul style="list-style-type: none"><li>Calculate the mass of <math>\text{SO}_4^{2-}</math>.</li></ul>
$\begin{aligned} \% \text{ mass sulfate} &= \frac{\text{mass of sulfate in prec pitate}}{\text{mass of fertiliser sample}} \times 100 \\ \% \text{ mass sulfate} &= \frac{3.4}{10.0} \times 100 = 34\% \end{aligned}$	<ul style="list-style-type: none"><li>Calculate the percentage of sulfate in the fertiliser.</li></ul>

### TRY THESE YOURSELF

- 1 A 10.0 mL solution of water containing  $\text{Cl}^-$  was treated with excess  $\text{AgNO}_3$ . The  $\text{AgCl}$  precipitate was filtered, dried and weighed. It was found to have a mass of 0.437 g. Calculate the concentration of  $\text{Cl}^-$  in the sample.
- 2 A 2.00 g sample of limestone was dissolved in hydrochloric acid and all the calcium present in the sample was converted to  $\text{Ca}^{2+}(\text{aq})$ . Excess ammonium oxalate solution  $(\text{NH}_4)_2\text{C}_2\text{O}_4(\text{aq})$  was added to the solution to precipitate the calcium ions as calcium oxalate,  $\text{CaC}_2\text{O}_4(\text{s})$ . The precipitate was filtered, dried and weighed to a constant mass of 2.43 g. Determine the percentage by mass of calcium in the limestone sample.
- 3 A 1.50 g sample of pesticide was analysed for its arsenic content. The arsenic was precipitated as diarsenic sulfide ( $\text{As}_2\text{S}_3$ ). If 0.185 g of  $\text{As}_2\text{S}_3$  was produced, what was the percentage by mass of arsenic in the pesticide?

## Errors in gravimetric analysis

Possible sources of error that may occur during gravimetric analysis include:

- ▶ contamination with other species
- ▶ loss of sample due to inefficient filtering, spillage or rinsing of containers
- ▶ not all the desired species precipitating out of solution
- ▶ water still remaining in the final sample.

Investigation 14.5 provides an opportunity to conduct a gravimetric analysis of lawn fertiliser.



Quantitative  
analysis of ions

## INVESTIGATION 14.5

### Measuring the sulfate content of lawn fertiliser

#### INTRODUCTION

Quantitative analysis is the process of determining the amounts of specific substances in samples. In some analyses, the species to be measured is precipitated out as an insoluble compound that is then filtered off, dried and weighed. This is known as gravimetric analysis. This technique can be used to determine the amount of sulfate in lawn fertiliser. You will be provided with a sample of lawn fertiliser, and your task is to design an experiment to determine the percentage of sulfate in the sample.

#### AIM

Write an aim for this investigation.

#### HYPOTHESIS

Write a hypothesis for this investigation.

#### HINTS

- 1 Materials:** Think about what you have learnt about identifying sulfate ions. (Remember an acidified solution of  $\text{Ba}^{2+}$  ions produces a thick white precipitate with  $\text{SO}_4^{2-}$  ions.) Consider which chemicals are necessary for identifying sulfate ions and how the resultant precipitate might be measured. Write a list of materials. You shouldn't use too much fertiliser; approximately 1 g should be enough.
- 2 Safety:** Note any safety considerations, especially the use of acids and disposal of the precipitate formed.
- 3 Method:** Write the steps you will follow in conducting the experiment. Ensure that you add the barium solution gradually (drop by drop) until no more precipitate appears. Gently heating, not boiling, the precipitate solution for about an hour will facilitate filtration. Remember that you will need to dry the precipitate as the end product.
- 4** Draw up a table to record your results.

#### ANALYSIS OF RESULTS

- 1** Write a balanced equation for the reaction used to separate the sulfate.
- 2** Calculate the mass of  $\text{BaSO}_4$  formed.
- 3** Calculate the mass of sulfate ion in the resultant precipitate by multiplying the mass of  $\text{BaSO}_4$  formed by the relative formula mass of  $\text{SO}_4^{2-}$  and then dividing by the relative formula mass of  $\text{BaSO}_4$ .
- 4** Calculate the percentage of sulfate in the original sample of fertiliser by dividing the mass of sulfate ions by the original mass of fertiliser used in the investigation and then multiplying by 100.



## » DISCUSSION

- 1 Compare your result with the stated amount on the packet. Suggest reasons for any differences.
- 2 Discuss the effect of the following factors on the accuracy of the experiment and how errors could be minimised.
  - Solubility of barium sulfate
  - Contamination of the precipitate with impurities
  - Passage of fine particles of barium sulfate through the filter paper
  - Losses of precipitate during mechanical transfer of the precipitate from the beaker to the filter paper and washing of the precipitate
  - Non-reproducibility of drying the filter paper

- Precipitation titrations can be used to determine the concentration of an ion in solution.
- Gravimetric analysis is a quantitative technique that uses the mass of a substance to determine amounts.

- 1 Describe the difference between a precipitation titration and gravimetric analysis.
- 2 Compare the three methods used to determine the end point of a precipitation titration by considering:
  - a pH
  - b type of titration
  - c species being analysed.
- 3 List possible sources of error that can occur in gravimetric analysis.
- 4 A seawater sample is analysed for its NaCl content by diluting 20 mL of the sample to 100 mL and titrating 25 mL volumes with a  $0.12 \text{ mol L}^{-1}$   $\text{AgNO}_3$  solution using Mohr's method. An average of 24.5 mL of silver nitrate solution was required to reach the end point. A blank titration required 0.6 mL to achieve a colour change of the indicator.
  - a Calculate the average number of moles of  $\text{Cl}^-$  in the 25 mL volumes.
  - b Calculate the number of moles in the original 20 mL sample.
  - c Calculate the NaCl content in  $\text{g mL}^{-1}$ .
- 5 A wastewater sample of mine run-off is analysed for its cyanide ion content using Volhard's method. A 25 mL sample is mixed with 50 mL of  $0.12 \text{ mol L}^{-1}$   $\text{AgNO}_3$ . The sample is back titrated with a  $0.27 \text{ mol L}^{-1}$  thiocyanate solution. The average amount of thiocyanate used is 14.4 mL. Calculate the concentration of cyanide ions in the sample.
- 6 A 3.00 g sample of an alloy (containing only Pb and Cu) was dissolved in nitric acid ( $\text{HNO}_3$ ). Sulfuric acid was then added to this solution, which precipitated 1.69 g of  $\text{PbSO}_4$ . Assuming that all of the lead was precipitated:
  - a what is the percentage of Pb in the sample?
  - b what is the mass of Cu in the alloy?

**CHECK YOUR  
UNDERSTANDING**  
14.5



## 14.6 Instrumental quantitative techniques

Instrumental techniques are being used much more commonly and they are particularly effective when the concentration of the species being analysed are very low. While precipitation titrations and gravimetric analysis are useful for analysing samples where the concentration is greater than 1–10 mg, instrumental techniques are more sensitive and therefore can be effective even when concentrations are below 1 ppm. In this section, atomic absorption spectroscopy and colourimetry, which are commonly used in inorganic analysis, will be discussed. While ultraviolet–visible spectrophotometry is also used in inorganic analysis it also used extensively in organic analysis so this technique will be considered in the next chapter.

### Atomic absorption spectroscopy

**Atomic absorption spectroscopy (AAS)** is used to perform quantitative analysis (that is, to find the amount of an element present). Atomic absorption spectroscopy uses the absorption of light by electrons in the atom to measure how much of an element is present in a sample of a substance.

AAS is widely used to determine the concentration of metal ions present in particular substances, especially when these metal ions are extremely toxic to humans and if ingested in large enough amounts can cause severe illness, DNA damage and even death. For example, mercury, lead, aluminium, arsenic and cadmium are found in small amounts in humans because of everyday contact with materials and the environment. These elements are sometimes known as heavy metals because they have quite high atomic masses.

Lead was used in paints and pigments to give them useful properties, as seen in Figure 14.12. Recently, a large number of toys made in China were recalled. Children in the USA and Europe had become violently ill after playing with toys that had paints and pigments containing lead. Researchers from Greenpeace bought 500 toys in five Chinese cities and conducted tests that showed 1 in 10 of the toys contained dangerous levels of lead, with one containing 1200 times the amount of lead permitted under European safety standards.



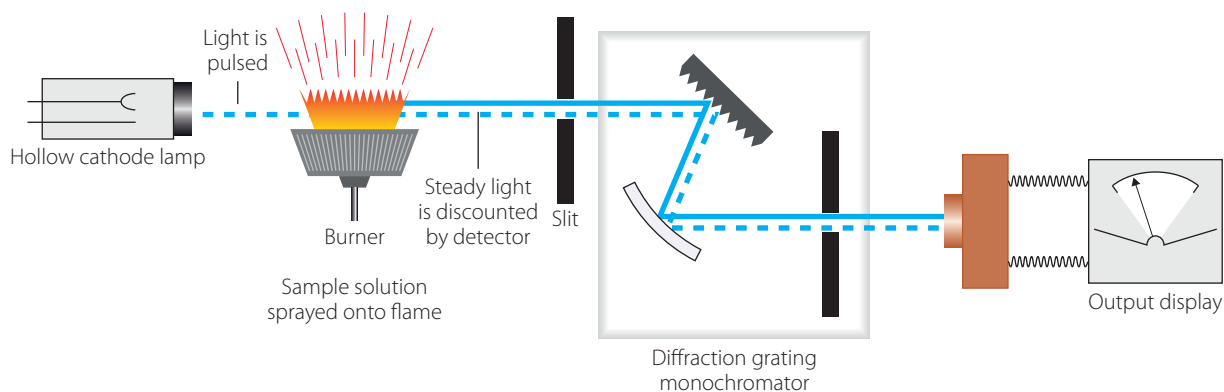
FIGURE 14.12 Lead-based substances

Accumulation of aluminium in the human body can lead to osteoporosis, headaches and problems with liver and kidney function. You come into contact with aluminium through deodorants, drinking water, medications and some processed foods.

Atomic absorption spectroscopy is able to detect low levels of metal ions, so potential problems can be identified.

## How it works

This process of AAS uses an atomic absorption spectrometer. The basic outline of the process is seen in Figure 14.13.



**FIGURE 14.13** The process of atomic absorption spectroscopy

First, the element being analysed is determined. This is important because the element in question is usually part of a sample of material such as food, paint or soil. Since there are multiple elements present in these substances, shining normal light through them would be useless – all the elements would absorb the light; therefore, only one element is focused on.

The lamp for this process is made of the same element that is being tested. If zinc is being tested for, then the lamp is made of zinc. If mercury is being tested for, then the lamp is made of mercury. An electric current is passed through a gaseous sample of the element so it will emit light, as described previously. When the lamp is made of a single element, then the light emitted has only the unique set of wavelengths particular to that element.

The sample being tested is **vaporised**, changing the substances it contains into atoms. When the light from the lamp passes through the vaporised sample, only the element being tested for will absorb the light from the lamp. This is because it has the same energy levels as the atoms that emitted the light from the lamp. Other elements in the vaporised sample will not absorb this light because the energy levels of all other atoms are different and their electrons cannot absorb the energies of the light present.

The light passes through the sample and is focused through a slit before entering a **monochromator**. This selects just one wavelength of the light for analysis by the **detector**. The detector measures the intensity of the light, which is then displayed as a number. This number is not a concentration but rather a measure of the amount of light that passed through the sample without being absorbed. This is called an **absorbance** value. Although the absorbance value is not concentration, it is related to concentration because the greater the concentration, the more light is absorbed and therefore the less light that reaches the detector. So as concentration increases absorbance value decreases.

## Quantitative analysis

To measure the amount of an element present, the absorbance of the sample is compared to that of known samples. This is done by constructing a **calibration curve**. First, a number of known concentrations of the element are prepared and their intensities are measured by atomic absorption spectroscopy. Then, a calibration curve of concentration against absorbance value is plotted. This allows the concentration of another sample to be compared and determined once its absorbance is measured.

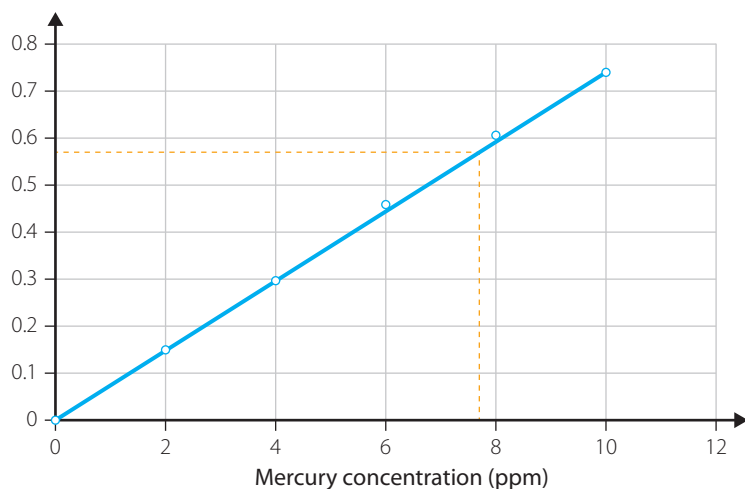
### ▶ WORKED EXAMPLE (14.4)

To determine the concentration of mercury in a sample of fish, the absorbances of some mercury samples of known concentration were measured by atomic absorption spectroscopy. Table 14.9 shows the results obtained. The fish sample was then analysed. Its absorbance value was 0.57. Determine the concentration of the fish sample.

**TABLE 14.9** Measurements of absorbance of known concentrations of mercury

MERCURY CONCENTRATION (ppm)	ABSORBANCE
2.0	0.15
4.0	0.30
6.0	0.46
8.0	0.61
10.0	0.74

#### ANSWER



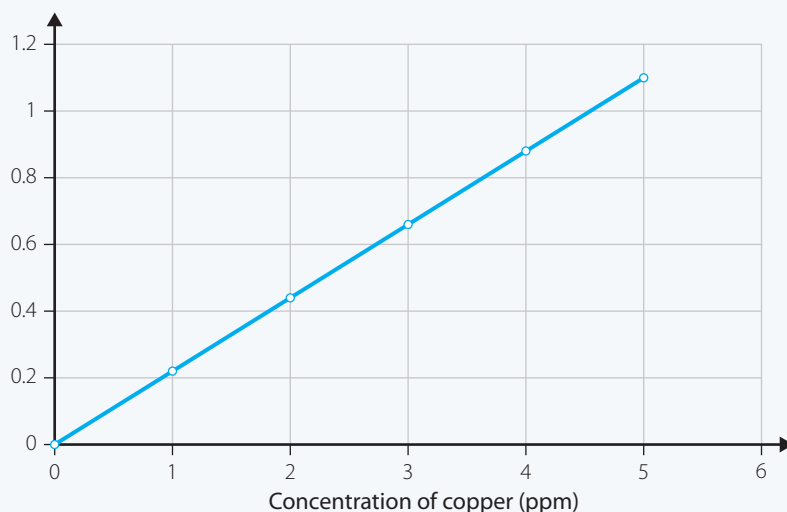
This gives an answer of 7.7 ppm.

#### LOGIC

- Construct a calibration graph as described above.
- By using interpolation on this graph, you can determine the concentration of the unknown sample.

### TRY THESE YOURSELF

Run-off water from a copper mine is suspected of having dangerous levels of copper. A calibration curve is shown in Figure 14.14 for known concentrations of copper.



**FIGURE 14.14** Calibration curve for determination of copper concentration

- 1 Samples of the water from the mine were analysed and the following absorbance values were obtained. For each absorbance reading below, use the graph to determine the concentration of copper in each sample.
  - a 0.75
  - b 0.30
- 2 A sample of soil was suspected of containing high levels of lead, which is dangerous for people working with that soil. To determine the concentration of lead in the soil, a lead lamp was used in the spectroscope to analyse the soil. Lead samples of known concentration were analysed and the data in Table 14.10 were obtained.

**TABLE 14.10** Measurements of absorbance of known concentrations of lead

LEAD CONCENTRATION (ppm)	ABSORBANCE
1.0	0.083
2.0	0.164
4.0	0.331
6.0	0.497

- a Construct a calibration curve with the concentration of lead on the horizontal axis and the absorbance on the vertical axis.
- b The sample of soil gave an absorbance reading of 0.290. From the graph, determine the concentration of lead in the soil.
- c Safe levels of lead in the soil are less than 3.5 ppm. Explain whether this sample of soil would be safe to work with.

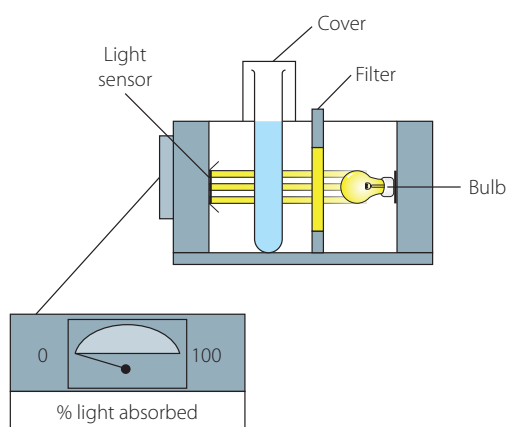
## Colourimetry

**Colourimetry** is a method for determining the concentration of a chemical in a solution using its colour and concentration in a solution. While ultraviolet-visible spectrophotometry is used for measuring radiation absorbed by a coloured species across a range of frequencies, colourimetry focuses on only one frequency, usually in the visible spectrum. This technique could be considered to be a simple version of UV-visible spectrophotometry (which will be discussed in the next chapter).

In section 14.3, the presence of particular cations were identified by flame colours and the colours of the precipitates they produced. Colourimetry enables the concentration of particular species to be identified using the fact that the colour intensity is proportional to concentration – the higher the concentration the more intense the colour. An instrument named a **colorimeter** measures the amount of a specific wavelength of light absorbed by the chemical being analysed.

Colourimetry can be used to find the concentration of any coloured species. In chapter 3, Investigation 3.2 (page 63), colourimetry was introduced and used to determine the equilibrium constant for the reaction  $\text{Fe}^{3+}(\text{aq}) + \text{SCN}^{-}(\text{aq}) \rightleftharpoons \text{FeSCN}^{2+}(\text{aq})$ .

It is widely used in industry, including the food and beverage industry for quality control of products, in the analysis of fertilisers for manganese and iron(III), and in environmental monitoring for measuring contaminants in soil and water. Colourimetry is also used in forensics to determine the presence of toxic metal ions such as lead, cadmium and chromium in a wide variety of samples (including urine).



**FIGURE 14.15** The process by which a colourimeter works

### How it works

The process by which a colourimeter works is similar to the process used in atomic absorption spectroscopy discussed previously.

Light from a bulb is passed through a filter to produce the required wavelength that is absorbed by the species being analysed. The solution is placed in a special **glass cuvet** (a special type of test tube). The filtered light passes through the solution and some is absorbed. The amount of light absorbed is measured by a detector. This process is shown in Figure 14.15.

A cuvet of distilled water (called a blank) is used to calibrate the instrument by setting it to read zero.

The particular filter that is used depends on the colours that are absorbed by the chemical species being investigated. The **complementary colour** to that of the solution is used for the filter. Remember from junior science that the colour seen is complementary to the colour absorbed.

For example, a blue solution appears blue because all other colours have been preferentially absorbed and only the blue passes through. Yellow (the complementary colour to blue) is most strongly absorbed, so in order to measure changes in absorbance of a blue solution a yellow filter is used allowing the transmission of yellow light (wavelength 580–595 nm). As the concentration of the species in solution increases more of the yellow light is absorbed and so absorbance increases.

The filter must be chosen to match the band of wavelengths that are most strongly absorbed by the coloured solution.

### Quantitative analysis

The process for analysing data using colourimetry is the same as that for atomic absorption spectroscopy. Absorbance data is obtained from samples of known concentration and this data is used to construct a calibration curve of concentration versus absorbance. The absorbance of a sample of an unknown concentration of the same species is measured and the calibration curve is used to determine the concentration in the sample.



Instrumental  
quantitative  
techniques

## INVESTIGATION 14.6

### Using colourimetry to construct a calibration curve to measure concentration of copper(II) sulfate

#### INTRODUCTION

Copper sulfate solution has a blue colour; the intensity of the colour is directly related to the concentration of the solution. A number of methods can be used to determine the intensity of the colour. A simple light meter will determine the intensity of light passing through a solution. The more light that is absorbed, the more concentrated the solution is. A colourimeter shines light of a particular wavelength through the sample and measures an absorbance value in a similar way to an atomic absorption spectrometer.

In this investigation, you will measure the intensity of light passing through copper sulfate samples of different concentration and construct a calibration curve. You will then be provided with a sample of copper sulfate of unknown concentration and will use your calibration curve to determine the concentration of this solution.

#### AIM

To determine the concentration of a solution of copper(II) sulfate through construction and use of a calibration curve.

#### MATERIALS

- Light source and light meter, colourimeter or colourimeter data probe with data logger or laptop
- 35 mL 1.0 mol L<sup>-1</sup> solution of copper(II) sulfate
- Distilled water
- 50 mL beaker
- 10 mL measuring cylinder

WHAT ARE THE RISKS IN DOING THIS INVESTIGATION?	HOW CAN YOU MANAGE THESE RISKS TO STAY SAFE?
Use of chemicals	
Use of light meter or data logger	



What other risks are associated with your investigation? How can you manage these? In particular, expand on the two risks listed to identify specific risks involved with each of them.

#### METHOD

- Collect approximately 35 mL of 1.0 mol L<sup>-1</sup> copper(II) sulfate.
- Regardless of the apparatus you are using, you will be using a piece of clear glassware to hold your sample of copper(II) sulfate. Measure 10 mL into this piece of glassware, or fill the provided container to overflowing.
- Take a reading of the absorbance of light by the sample. This will be provided as a readout on your light meter or colourimeter.
- Measure 8 mL of the 1.0 mol L<sup>-1</sup> copper sulfate solution into a 10 mL measuring cylinder and make up to 10 mL with distilled water. This will provide you with a 0.8 mol L<sup>-1</sup> copper sulfate solution.
- Repeat steps 2 and 3 to determine an absorbance reading for this sample.
- Measure 6 mL of the 1.0 mol L<sup>-1</sup> copper sulfate solution into a 10 mL measuring cylinder and make up to 10 mL with distilled water. This will provide you with a 0.6 mol L<sup>-1</sup> copper sulfate solution.
- Repeat steps 2 and 3 to determine an absorbance reading for this sample.
- Measure 4 mL of the 1.0 mol L<sup>-1</sup> copper sulfate solution into a 10 mL measuring cylinder and make up to 10 mL with distilled water. This will provide you with a 0.4 mol L<sup>-1</sup> copper sulfate solution.
- Repeat steps 2 and 3 to determine an absorbance reading for this sample.



- » 10 Measure 2 mL of the  $1.0 \text{ mol L}^{-1}$  copper sulfate solution into a 10 mL measuring cylinder and make up to 10 mL with distilled water. This will provide you with a  $0.2 \text{ mol L}^{-1}$  copper sulfate solution.
- 11 Repeat steps 2 and 3 to determine an absorbance reading for this sample.
- 12 Collect 10 mL of the unknown concentration sample.
- 13 Repeat step 2 and 3 to determine an absorbance reading for this sample.

#### RESULTS

- 1 Draw up a table of results showing your known concentrations and their absorbances. Include the result for the unknown concentration in this table.
- 2 Construct a fully-labelled calibration curve for your known results.
- 3 Use the graph to determine the concentration of the unknown sample.

#### ANALYSIS OF RESULTS

- 1 Did your graph pass through the origin (0,0)? Why should you expect it to? Suggest reasons why your graph might not do this.
- 2 Compare your results to those of other groups. Did you all get the same answer? If possible, create a table showing a class set of results. Account for any differences.

#### DISCUSSION

- 1 If your teacher can tell you the correct concentration of the unknown sample, discuss the accuracy of your results (that is, how close you got to the true value).
- 2 Identify one error that may have affected your results. Discuss its effect on the results. Identify the error as random or systematic.

#### CONCLUSION

Write a conclusion that discusses the results of this investigation.

- Atomic absorption spectroscopy relies on electron transfer between atomic energy levels and can be used to identify elements.
- Colourimetry uses absorbance of light in the visible spectrum by coloured species in solution, and can be used to determine the concentration of ions and compounds.

#### CHECK YOUR UNDERSTANDING

14.6

- 1 **a** Describe briefly the process of atomic absorption spectroscopy.  
**b** Compare AAS with the process of colourimetry.
- 2 Explain how you would construct a calibration curve for the process of atomic absorption spectroscopy or colourimetry.
- 3 Explain why the lamp in atomic absorption spectroscopy is made from the same element as the element being tested.
- 4 In a colourimetry investigation, a student was using a blue filter to analyse a blue solution. Comment on the appropriateness of using a blue filter, providing reasons for this.



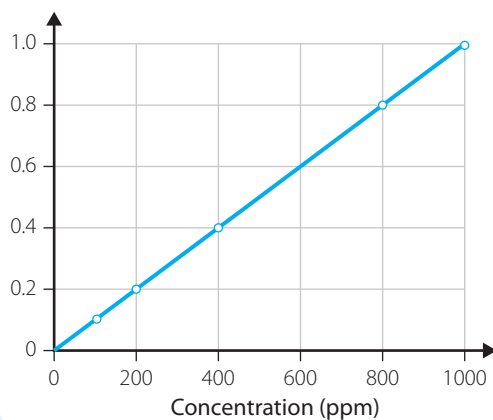


- 5 Cadmium is useful in small amounts but dangerous in large amounts. A sample of paint was tested for its cadmium content. Samples of known concentration of cadmium were analysed by atomic absorption spectroscopy and the results in Table 14.11 were obtained.

**TABLE 14.11** Measurements of absorbance of known concentrations of cadmium

CADMIUM CONCENTRATION ( $\text{mg L}^{-1}$ )	ABSORBANCE
0.0	0.000
1.0	0.038
2.0	0.082
3.0	0.120
4.0	0.160
5.0	0.200
6.0	0.240
Unknown	0.110

- Construct a calibration curve for the known concentrations of cadmium.
  - From the curve, determine the concentration of cadmium in the sample of paint.
- 6 A solution of copper(II) tetrammine,  $[\text{Cu}(\text{NH}_3)_4(\text{H}_2\text{O})_2]^{2+}$  was analysed using colourimetry to determine its concentration. It was diluted by a factor of 100 and found to have an absorbance reading of 0.6.
- Use Figure 14.16 to determine the concentration of the diluted sample in ppm.
  - What is the concentration of the original undiluted sample in ppm?
  - Suggest a reason for diluting the solution.



**FIGURE 14.16** A typical calibration curve for copper(II) tetrammine ions at 610 nm



- 7 Fertiliser run-off into a local creek caused great concern to the local residents since a significant degree of eutrophication was beginning to occur. The residents contacted the EPA and asked if the levels in the creek were above the typical clean water values. The EPA scientists collected samples from two different sites and then tested these.

Calibration samples were prepared by reacting a stock phosphorous solution with ammonium molydate/ ammonium metavanadate solution to produce a yellow coloured solution. A colourimeter with a blue filter was used to measure the absorbance of known concentrations. The results are shown in Table 14.12.

**TABLE 14.12** Measurements of absorbance of known concentrations of phosphorus

PHOSPHORUS CONCENTRATION ( $\text{mg L}^{-1}$ )	ABSORBANCE
0.0	0.15
0.05	0.28
0.15	0.45
0.25	0.63
0.35	0.80
Unknown sample 1	0.31
Unknown sample 2	0.18

- Construct a calibration curve for the known concentrations of phosphorus.
- Calculate the phosphorus concentrations in the two samples.
- If the water quality objective for phosphorus is  $60\mu\text{L}^{-1}$ , comment on the health of the waterway with regard to this parameter.
- Explain why a blue filter was used in the colorimeter.

# 14 CHAPTER SUMMARY

## IMPORTANT NEW TERMS

After studying this chapter you should know the meaning of the following terms:

absorbance (p. 435)

absorption indicator (p. 428)

atomic absorption spectroscopy (AAS) (p. 434)

calibration curve (p. 436)

colourimeter (p. 438)

colourimetry (p. 438)

complementary colour (p. 438)

complexation reaction (p. 417)

complex ion (p. 417)

detector (p. 435)

electron configuration (p. 409)

excited state (p. 409)

glass cuvet (p. 438)

gravimetric analysis (p. 431)

ground state (p. 409)

monochromator (p. 435)

vaporised (p. 435)

wavelength (p. 409)

## AFTER STUDYING THIS CHAPTER YOU SHOULD KNOW:

- ▶ the definitions for all terms in the important new terms list
- ▶ why environmental monitoring is needed
- ▶ why some metal cations produce a coloured flame
- ▶ tests that can be used to identify specific cations
- ▶ tests that can be used to identify specific anions
- ▶ what complex ions are and how they differ to other ions
- ▶ how the end point is determined in a precipitation titration
- ▶ the process of atomic absorption spectroscopy
- ▶ the process of colourimetry.

## YOU SHOULD BE ABLE TO:

- ▶ write balanced equations for precipitation reactions
- ▶ use flame test results to identify metal cations
- ▶ use solubility data to predict the formation of precipitates
- ▶ conduct flame tests
- ▶ use precipitation tests to identify cations and anions
- ▶ design and conduct investigations to identify cations and anions
- ▶ interpret formula for complex ions
- ▶ calculate concentrations from precipitation titration data
- ▶ process data from gravimetric analysis
- ▶ draw and interpret a calibration curve
- ▶ calculate quantities from atomic absorption and colourimetry data.



- 1 Explain why flame tests should not be used alone to identify cations.
- 2 Use an example to justify the need for monitoring the environment.
- 3 Write ionic equations (net or neutral species) for the reactions that occur when the following solutions are mixed.
  - a Barium chloride and sodium sulfate
  - b Copper sulfate and potassium phosphate
  - c Calcium chloride and sodium nitrate
  - d Silver nitrate and sodium bromide
  - e Lead nitrate and potassium iodide
- 4
  - a A solution was thought to contain either silver nitrate or barium nitrate. Samples of the solution gave white precipitates with dilute HCl, H<sub>2</sub>SO<sub>4</sub> and NaOH. Which of these compounds is present? Explain.
  - b Samples of a solution gave a white precipitate with Na<sub>2</sub>SO<sub>4</sub> and a brick-red flame colour. Did the solution contain lead nitrate or calcium chloride? Explain.
  - c A solution was known to contain either potassium carbonate or sodium iodide. Samples of the solution gave no bubbles of gas with HNO<sub>3</sub> but did give precipitate with AgNO<sub>3</sub>. Which of the anions is present? Explain.
- 5 A solution was known to contain either Fe<sup>2+</sup> or Fe<sup>3+</sup> ions. Describe the minimum number of tests that could be performed to decide which of these ions is present in the solution.
- 6
  - a Use an example and a diagram to describe what a complex ion is.
  - b What information does the formula [Al(H<sub>2</sub>O)<sub>6</sub>]<sup>3+</sup> provide?
  - c Explain the bonding formed between the central cation and the attached ligands.
  - d When writing precipitation reactions, the formula for the complex ion is often omitted or simplified. Explain why this may be done using an example.
- 7
  - a Cu<sup>2+</sup> coordinates with 4Cl<sup>-</sup> to form a complex ion. Write the formula of the complex ion using the accepted conventions.
  - b Explain why the precipitate Cu(OH)<sub>2</sub> dissolves when excess ammonia (NH<sub>3</sub>) is added to a solution containing this precipitate.
- 8 A solution was known to contain two of the following anions: CO<sub>3</sub><sup>2-</sup>, Cl<sup>-</sup>, PO<sub>4</sub><sup>3-</sup>, SO<sub>4</sub><sup>2-</sup>.

The following tests were conducted: a white precipitate formed with the addition of silver nitrate that darkened in sunlight and bubbles formed when dilute HNO<sub>3</sub> was added. Suggest which anions are present in the solution.
- 9 In a precipitation titration to determine the concentration of iodide ions in solution a student added 54.00 mL of 2.1 mol L<sup>-1</sup> AgNO<sub>3</sub> to 46.00 mL of an iodide solution. 20 mL of the solution containing the excess silver nitrate was titrated against 31.00 mL of 0.6973 mol L<sup>-1</sup> sodium thiocyanate solution. Calculate the molar concentration of iodide ions in solution.
- 10 25.0 mL of seawater was diluted to 250 mL in a graduated volumetric flask. A 25.0 mL aliquot of the diluted seawater was pipetted into a conical flask and a few drops of potassium chromate(VI) indicator solution was added. A blank titration required 0.20 mL to obtain indicator colour change.

On titration with 0.100 mol L<sup>-1</sup> silver nitrate solution, 13.8 mL was required to precipitate all the chloride ions.

  - a Give the ionic equation for the reaction of silver nitrate and chloride ion.
  - b Calculate the moles of chloride ion in the titrated 25.0 mL aliquot.
  - c Calculate the molarity of chloride ion in the diluted seawater.
  - d Calculate the molarity of chloride ion in the original seawater.
  - e Assuming that for every chloride ion there is a sodium ion, what is the theoretical concentration of sodium chloride salt in g L<sup>-1</sup> in seawater?
- 11 0.12 g of rock salt was dissolved in water and titrated with 0.100 mol L<sup>-1</sup> silver nitrate, using Mohr's method, until the first permanent brown precipitate of silver chromate is seen. 19.7 mL was required to titrate all the chloride ion.
  - a How many moles of chloride ion were titrated?
  - b What mass of sodium chloride was titrated?
  - c What was the % sodium chloride by mass in the rock salt?
  - d Comment on the accuracy of the analysis.

- 12** A chain of coffee shops started giving away brightly coloured drinking mugs. It was thought that lead compounds had been used in the paint and that this dissolved in acidic drinks such as soft drinks and fruit juices.

Design an experiment to determine:

- whether lead is present in the paint
  - the quantity of lead dissolved in 100 mL of an acidic drink.
- 13** Scientists were concerned about the amount of barium ions in drinking water. They used atomic absorption spectroscopy to determine the concentration in various samples. First they used samples of known concentration to calibrate their instrument, then measured the absorption of samples collected from several sources.

Absorbance of the standards are given below:

STANDARD (ppm)	1	2	4	6	7
ABSORBANCE	0.2	0.35	0.7	1.05	1.2

- Draw a calibration curve of the absorbance versus concentration (ppm) for the standards.
- The absorbance of three samples is given below:

SAMPLE	A	B	C
ABSORBANCE	0.3	0.9	1.3

Use the calibration curve to determine the concentration of barium ions in each of the three samples.

- 14** Iron is present in the human body in trace amounts. It is essential for making haemoglobin that binds oxygen to transport it throughout the body.
- Anaemia is due to iron deficiency: people with anaemia are generally weak. For people with this deficiency, taking iron tablets can be beneficial, but too much iron can cause cirrhosis of the liver.
- A group of students decided to use AAS to analyse three different brands of iron tablets to determine their content. They placed a tablet of brand A in a 100 mL beaker with 6 mol L<sup>-1</sup> HCl, covered it with a watch glass and heated it slowly for 15 minutes. They then filtered the solution into a 250 mL volumetric flask and allowed it to cool before topping it up to the mark with distilled water. They determined the absorbance of the sample and repeated the same process for the other two samples as well as a sample of known concentration.

SAMPLE	Standard (5.0 ppm)	A	B	C
ABSORBANCE	0.85	0.8	0.6	1.05

If, for iron, absorbance is inversely proportional to the concentration, calculate the concentration of iron (ppm) in each of the solutions tested and then in the tablets themselves. Each tablet had a mass of 100 mg. (Hint: ppm = mg L<sup>-1</sup>)

- 15** A sample of potassium chloride was thought to contain impurities. 0.450 g of the sample was dissolved in water and excess silver nitrate was added to the solution. The resulting precipitate was found to weigh 0.840 g.
- Calculate:
    - the mass of KCl in the original sample
    - the % of KCl in the original sample.
  - The impurity was believed to be either magnesium acetate or barium nitrate. Devise a series of tests that could be used to determine which is present.
- 16** Calcium and magnesium are important in many body systems. Tablets containing calcium and magnesium are often used as supplements. In a chemistry assignment, a student decided to check the amount of calcium and magnesium in a tablet. The information on the label of the bottle containing the tablets provided the following: total calcium per tablet 229 mg, total magnesium per tablet 115 mg.
- The student found the tablet to weigh 1.2 g. It was dissolved in 100 mL of warm distilled water and excess sodium sulfate was added to precipitate the calcium ions. The solution was filtered. The precipitant was dried and this had a weight of 666 mg. Excess sodium carbonate was added to the filtrate to precipitate magnesium carbonate, which was filtered, dried and weighed. The dry weight was 149 mg.
- Assume the precipitants contained only the calcium and magnesium ions.
- Calculate:
    - the mass of calcium in the tablet
    - the mass of magnesium in the tablet.
  - Compare the values found experimentally and the claims on the label.
  - Suggest possible experimental errors that may account for any differences.

- 17** A bottle of potassium dichromate of unknown concentration was found on a laboratory shelf. Rather than dispose of it, the laboratory technician decided to use colourimetry to determine the concentration. Reference samples were prepared and the following absorbance data obtained:

REFERENCE SAMPLE CONCENTRATIONS ( $\text{mol L}^{-1}$ )	ABSORBANCE
0.05	0.69
0.04	0.55
0.03	0.41
0.02	0.27

- a** Draw a calibration curve using the reference data.
- b** The absorbance of the sample of unknown concentration was found to be 0.60. What is the concentration of this sample?

- 18** A tap water sample was tested and found to contain copper ions. Addition of excess ammonia to a 20 mL sample produced the dark blue complex of copper(II) tetraammine ions. The sample was diluted to 200 mL with distilled water.

A colourimeter was used to determine the absorbance of the diluted sample. The absorbance of the solution was found to be 0.1.

- a** Use Figure 14.14 (page 437) to determine the concentration of copper(II) tetraammine ions in the diluted sample.
- b** Calculate the concentration of copper ions in the original sample.
- c** Drinking water regulations specify that a maximum safe concentration of copper is  $1.3 \text{ mg L}^{-1}$ . Explain whether the level of copper meets the regulations.

## 15

## Analysis of organic substances

## INQUIRY QUESTION

How is information about the reactivity and structure of organic compounds obtained?

## Students:

conduct qualitative investigations to test for the presence in organic molecules of the following functional groups:

- carbon–carbon double bonds
- hydroxyl groups
- carboxylic acids (ACSCH13)

investigate the processes used to analyse the structure of simple organic compounds addressed in the course, including but not limited to:

- proton and carbon-13 NMR
- mass spectroscopy (ACSCH1)
- infrared spectroscopy (ACSCH13)

conduct investigations and/or process data to determine the concentration of coloured species and/or metal ions in aqueous solution including but not limited to, the use of:

- colourimetry
- ultraviolet-visible spectrophotometry
- atomic absorption spectroscopy.

Chemistry Stage 6 Syllabus © NSW Educational Standards Authority for and on behalf of the Crown in right of the State of New South Wales, 2017







Prior  
knowledge

There are millions of natural and synthetic organic compounds. We depend on organic molecules in every aspect of our lives. The food we eat, the medicines used to fight disease, the fossil and biofuels used for energy production and even our bodies are largely made up of organic compounds.

Chemists are continually identifying and isolating new organic compounds found in plants and animals in the environment, and they are also synthesising new ones. To do this, they have to determine the structures of organic compounds to understand how bonds form and how molecules react. Understanding the details down to the individual atom has revolutionised the development of new organic compounds and further knowledge of ones already known and widely used.



**FIGURE 15.1** Chemists can synthesise aspirin tablets because the structure of aspirin is well known.

## 15.1 Chemical tests for functional groups

In chapters 8 to 12, you learnt about the physical and chemical properties of some classes of organic compounds and also about many uses of these compounds. Table 15.1 summarises the classes of organic compounds you have previously studied.

**TABLE 15.1** Some classes of organic compounds

CLASS	SUFFIX	IDENTIFYING ASPECT OR FUNCTIONAL GROUP	GENERAL FORMULA	EXAMPLE	NAME OF EXAMPLE
Alkane	-ane	Hydrocarbon with only single bonds	$C_nH_{2n+2}$	$\begin{array}{c} \text{H} & \text{H} \\   &   \\ \text{H}-\text{C} & - & \text{C}-\text{H} \\   &   \\ \text{H} & \text{H} \end{array}$	Ethane
Alkene	-ene	Hydrocarbon with at least one double bond	$C_nH_{2n}$	$\begin{array}{c} \text{H} & & \text{H} \\ & \diagdown & / \\ & \text{C}=\text{C} & \\ & / & \diagdown \\ \text{H} & & \text{H} \end{array}$	Ethene
Alkyne	-yne	Hydrocarbon with at least one triple bond	$C_nH_{2n-2}$	$\text{H}-\text{C} \equiv \text{C}-\text{H}$	Ethyne
Alcohol	-ol	-OH	R-OH	$\begin{array}{c} \text{H} & \text{H} \\   &   \\ \text{H}-\text{C} & - & \text{C}-\text{OH} \\   &   \\ \text{H} & \text{H} \end{array}$	Ethanol



»

CLASS	SUFFIX	IDENTIFYING ASPECT OR FUNCTIONAL GROUP	GENERAL FORMULA	EXAMPLE	NAME OF EXAMPLE
Aldehyde	-al	$\begin{array}{c} \text{O} \\    \\ \text{--- C --- H} \end{array}$	$\text{R --- C --- H}$	$\begin{array}{ccccc} & \text{H} & \text{H} & \text{O} & \\ &   &   &    & \\ \text{H} & \text{--- C ---} & \text{C ---} & \text{C ---} & \text{H} \\ &   &   & & \\ & \text{H} & \text{H} & & \end{array}$	Propanal
Ketone	-one	$\begin{array}{c} \text{O} \\    \\ \text{--- C ---} \end{array}$	$\text{R --- C --- R'}$	$\begin{array}{ccccc} & \text{H} & \text{O} & \text{H} & \\ &   &    &   & \\ \text{H} & \text{--- C ---} & \text{C ---} & \text{C ---} & \text{H} \\ &   & &   & \\ & \text{H} & & \text{H} & \end{array}$	Propanone
Carboxylic acid	-oic acid	$\begin{array}{c} \text{O} \\    \\ \text{--- C --- OH} \end{array}$	$\text{R --- C --- OH}$	$\begin{array}{ccccc} & \text{H} & \text{O} & & \\ &   &    & & \\ \text{H} & \text{--- C ---} & \text{C ---} & \text{OH} & \\ &   & & & \\ & \text{H} & & & \end{array}$	Ethanoic acid
Ester	alky -oate	$\begin{array}{c} \text{O} \\    \\ \text{--- C --- O --- R'} $	$\text{R --- C --- O --- R'}$	$\begin{array}{c} \text{O} \\    \\ \text{CH}_3 \text{ --- C --- O --- CH}_3 \end{array}$	Methyl ethanoate
Amine	-amine	—NH <sub>2</sub>	$\begin{array}{c} \text{H} \\   \\ \text{R --- N} \\   \\ \text{H} \end{array}$	$\begin{array}{ccccc} & \text{H} & \text{H} & & \\ &   &   & & \\ \text{H} & \text{--- C ---} & \text{C ---} & \text{N} & \\ &   &   & / \quad \backslash & \\ & \text{H} & \text{H} & \text{H} \quad \text{H} & \end{array}$	Ethanamine
Amide	-amide	$\begin{array}{c} \text{O} \\    \\ \text{--- C --- NH}_2 \end{array}$	$\text{R --- C --- NH}_2$	$\begin{array}{c} \text{O} \\    \\ \text{H --- C --- N} \\ \quad \quad \quad / \quad \backslash \\ \quad \quad \quad \text{H} \quad \text{H} \end{array}$	Methanamide

The properties and reactions can be used to distinguish between and identify different classes of organic compounds. The classes identified in Table 15.1 – alkanes, alkenes, alkynes, alcohols, carboxylic acids, esters, amines and amides – are the main ones considered in earlier chapters. Their properties and reactions can be used to distinguish between and identify different classes of organic compounds. While the process used is similar to that for identifying inorganic substances, the chemical reactions are different.

In devising a set of tests to distinguish between different classes of compounds, the most easily identified class is usually the starting point. In this course, you only need to be able to distinguish between alkenes, alcohols and carboxylic acids. Tests used to distinguish between these three classes are summarised in Table 15.2.

In chapters 10, 11 and 12 you conducted investigations involving reactions of alkenes, alcohols and carboxylic acids. These investigations, listed below, included many of the tests listed in Table 15.2:

- ▶ Investigation 10.4 Comparing reactivities of alkanes and alkenes (page 302)
- ▶ Investigation 11.2 Oxidation of alcohols (page 325)
- ▶ Investigation 12.1 Preparing simple esters (page 347)
- ▶ Investigation 12.2 Properties of organic acids and bases (page 351).

**TABLE 15.2** Tests for determining class of organic compounds

CLASS OF COMPOUND	TEST	RESULT
Carboxylic acid	Test with blue litmus.	If blue litmus turns red, the solution is acidic.
	Add drops of sodium carbonate solution to the sample.	If bubbles of colourless gas form (CO <sub>2</sub> , which can be identified by the limewater test), then the solution is a carboxylic acid.
Alkene	Add drops of bromine or bromine water to the organic solvent.	If the solution loses colour, then a multiple bond is present since it is decolourised by alkenes.
Alcohol	Add granules of calcium chloride to remove any water present, and then add a small piece of sodium. (Teacher demonstration only)	If bubbles of colourless gas form (H <sub>2</sub> , which can be identified by the pop test), then the sample is an alcohol. (Carboxylic acids also react the same way but they will already have been identified.)
	Add drops of bromine or bromine water.	The rate of H <sub>2</sub> formation also gives an indication of whether the alcohol is primary > secondary > tertiary. If the solution does not lose colour, it is an alcohol.
	Add small amount of glacial acetic acid and 2–3 drops concentrated sulfuric acid. Warm in a water bath for 10 minutes. Pour into cold water.	A fruity smell would indicate an ester produced from the alcohol present and the added carboxylic acid. Tertiary alcohols produce only small amounts of ester so may be difficult to detect presence.
	Add drops of acidified potassium permanganate (KMnO <sub>4</sub> ) to the sample.	Disappearance of the pink colour indicates the presence of a primary or secondary alcohol. Alkenes will also decolourise permanganate but they will already have been identified.

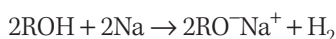


#### Tests for functional groups

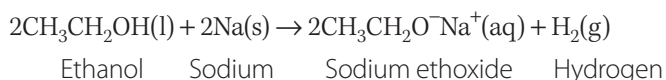
Use the information in the weblink to learn about other tests for functional groups.

## Alcohol reaction with sodium

Primary, secondary and tertiary alcohols react with sodium to form an **alkoxide** anion (RO<sup>−</sup>) and hydrogen gas. This is a similar reaction to the one between sodium and water but is less vigorous.

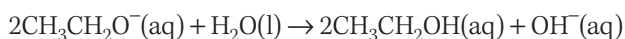


For example:



In this reaction, the alcohol acts as an acid. The alkoxide produced is a strong base and is the conjugate of the weak acid (which is the alcohol). The alkoxide readily reacts with water to form the original alcohol and produce OH<sup>−</sup> ions.

For example:



Sodium metal reacts vigorously with water, so when performing this test it is important to ensure any water is removed by adding granules of a dehydrating agent such as calcium chloride. Only a very small piece of sodium needs to be used – a rice grain size is all that is necessary.

The rate of production of hydrogen gas in this reaction can also be used to distinguish between primary, secondary and tertiary alcohols. The reaction proceeds fastest for a primary alcohol, a little slower for a secondary alcohol and slower again for a tertiary alcohol.

## INVESTIGATION 15.1

### Distinguishing between classes of organic compounds

#### INTRODUCTION

When identifying a compound, the first step is to determine which class of organic compounds the unknown substance belongs to. In this investigation, you will need to identify whether the unknown compound contains a carbon-carbon double bond, a hydroxyl group or is a carboxylic acid.

#### AIM

Write an aim for your investigation.

#### HYPOTHESIS

Write a suitable hypothesis for your investigation.

#### MATERIALS

Use the information on tests for distinguishing classes of organic compounds (Table 15.2) and previous investigations to consider what equipment you will need.

Complete a risk assessment for your investigation. Refer to safety considerations in similar investigations.

WHAT ARE THE RISKS IN DOING THIS INVESTIGATION?	HOW CAN YOU MANAGE THESE RISKS TO STAY SAFE?



Check the Safety Data Sheets for the compounds being used.

#### METHOD

Use the information on tests for distinguishing classes of organic compounds (Table 15.2) and previous investigations to draw a flow chart to outline the method you might follow.

You will need to confirm that the tests you are using work for that class of organic compound before identifying the unknown sample. This could be done by obtaining samples of a known carboxylic acid, alkene, primary, secondary and tertiary alcohol and conducting the tests on these before attempting to identify the unknown.

Write out a step-by-step method using the flow chart to help you.

#### RESULTS

- 1 Perform the identifying tests on the known compounds to confirm the reactions and record your observations in a table.
- 2 Obtain an unknown compound from your teacher and identify its class. If it is found to be an alcohol, you could try to determine whether it is primary, secondary or tertiary.

#### DISCUSSION

Write balanced equations for the reactions you used to distinguish between the different classes.

- 1 Which class is the most reactive? Which class is the least reactive?
- 2 Use your results to justify the identity of the unknown sample.

#### CONCLUSION

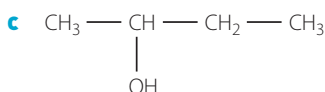
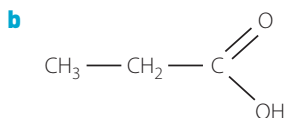
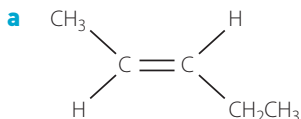
With reference to the results obtained and the discussion, write a conclusion for this investigation.

- The chemical properties of different classes of organic compounds can be used to distinguish between them.

## CHECK YOUR UNDERSTANDING

15.1

- Which, if any, of the following classes – alkene, carboxylic acid and alcohol – are soluble in water?
  - Explain if solubility would be a suitable way to distinguish these classes of compounds.
- Identify the class of organic compound and name the following compounds.



- For each of the following reactions, write a balanced equation and name any products formed.
  - Bromine water and propene
  - Sodium metal and 1-butanol
  - Ethanol and methanoic acid
  - Propanoic acid and sodium carbonate
  - Methanol and sodium metal
- A student wanted to use an esterification reaction to test for the presence of a carboxylic acid.
  - What reactants would the students need?
  - Compare the potential accuracy of this test to a different test that is used to identify carboxylic acids.
- Three compounds are known to be 1-propanol, ethanoic acid and 1-pentene. Write a method that could be used to identify the three compounds. Give expected results of any proposed tests.
- Four bottles containing clear liquids were found on the laboratory shelf, but the labels had fallen off. The missing labels were found on the floor and had the names: 1-hexene ( $\text{C}_6\text{H}_{12}$ ), pentane ( $\text{C}_5\text{H}_{12}$ ), water ( $\text{H}_2\text{O}$ ) and ethanol ( $\text{C}_2\text{H}_5\text{OH}$ ).

A group of chemistry students was asked to devise a series of tests to identify the contents of each of the four bottles. The students labelled the bottles A, B, C and D and conducted their tests. Their results are shown below.

BOTTLE	SOLUBLE IN WATER	FLAMMABLE	DECOLOURISES BROMINE IN THE ABSENCE OF UV LIGHT
A	Yes	No	No
B	No	Yes	Yes
C	No	Yes	No
D	Yes	Yes	No

- Using the information from the tests, identify which bottle contained which chemical, giving reasons for your decision.
- Write balanced equations for the chemical reactions that occurred.

## 15.2 Analytical techniques: Faster and better

Chemists have to determine the structures of organic compounds to be able to understand how bonds are formed and how molecules react. This enables a better understanding of how biological molecules such as DNA, enzymes and ribosomes function. Understanding the detail down to the individual atoms has revolutionised the development of new medicines and promises advances in the early diagnosis of cancers.

Key to the success in these medical fields is the instruments that enable chemists to determine the structures. Each instrument provides unique information. When the information from different instruments is combined, a three-dimensional view of the substance is built up. The chemist's role is to translate the information into a structure that makes sense.

The techniques being studied in this section are collectively described as organic spectrometry. Each spectrometer monitors the response of the molecule to different energy inputs (Table 15.3). In mass spectroscopy, it is high-energy electrons; nuclear magnetic resonance (NMR) spectroscopy uses radio waves; infrared (IR) spectroscopy uses heat energy; and ultraviolet-visible (UV-vis) spectrophotometry uses visible or UV light.

**TABLE 15.3** Energy sources and data output of the analytical technique

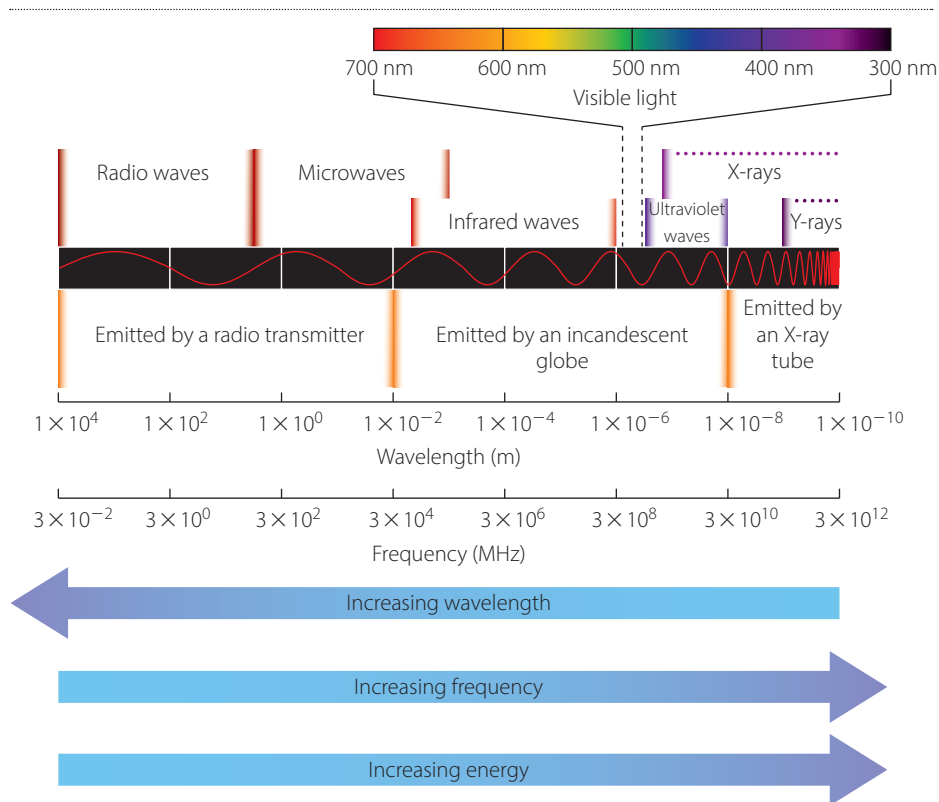
TECHNIQUE	ENERGY SOURCE	DATA OUTPUT
Mass spectroscopy	High-energy electrons	Peaks correlating to the $m/z$ ratio that indicate the molar mass and isotopic abundances.
NMR spectroscopy	Radio waves	Peaks that are useful for determining the C—H backbone of a molecule.
IR spectroscopy	Infrared waves	Bands used to determine the type of bonds and functional groups present. May identify the compounds using spectra as 'fingerprints'.
UV-vis spectrophotometry	UV-visible waves	Absorption spectra that show the concentration of organic compounds. May identify the compounds using spectra as 'fingerprints'.

Mass spectroscopy and NMR spectroscopy have allowed revolutionary breakthroughs in determining structure and function of molecules. Nobel Prizes in Chemistry have previously been given to the scientists who developed these two techniques.

### The electromagnetic spectrum

The electromagnetic spectrum is the general name given to the complete range of electromagnetic radiation that is emitted from the Sun. The radiation is emitted as waves that have a range of energies and wavelengths. Figure 15.2 shows the electromagnetic spectrum along with the wavelengths and frequencies of the different parts of the spectrum. We see only a small part of this range: the visible spectrum. The visible part of the spectrum can be split to show the colours of the rainbow. Red light has less energy and a longer wavelength than violet light. In chapter 14, you learnt about analysing samples using colourimetry that uses the visible part of the electromagnetic spectrum.

Spectroscopy techniques rely on the full electromagnetic spectrum. Each instrument uses a particular range of the spectrum that corresponds to the energy used by the technique.



**FIGURE 15.2** The electromagnetic spectrum (**Note:** The wavelength of the waves that make up visible light is so small that it is recorded in nanometres, nm ( $1 \text{ nm} = 10^{-9} \text{ m}$ ). The frequency of the waves has been measured in megahertz, MHz ( $1 \text{ MHz} = 10^6 \text{ Hz}$ ).

- Mass spectroscopy uses high-energy electrons; nuclear magnetic resonance (NMR) spectroscopy uses radio waves; infrared (IR) spectroscopy uses heat energy; and ultraviolet-visible (UV-vis) spectrophotometry uses visible or UV light.

### Review techniques

Test your knowledge as you learn about the techniques; view videos and animations.

## CHECK YOUR UNDERSTANDING

15.2

- 1 Describe how mass spectroscopy is different from the other three techniques listed.
- 2 Explain the advantage these techniques have over chemical analysis.
- 3 Comment on the statement: 'Colourimetry is a subset of UV-vis spectrophotometry'.

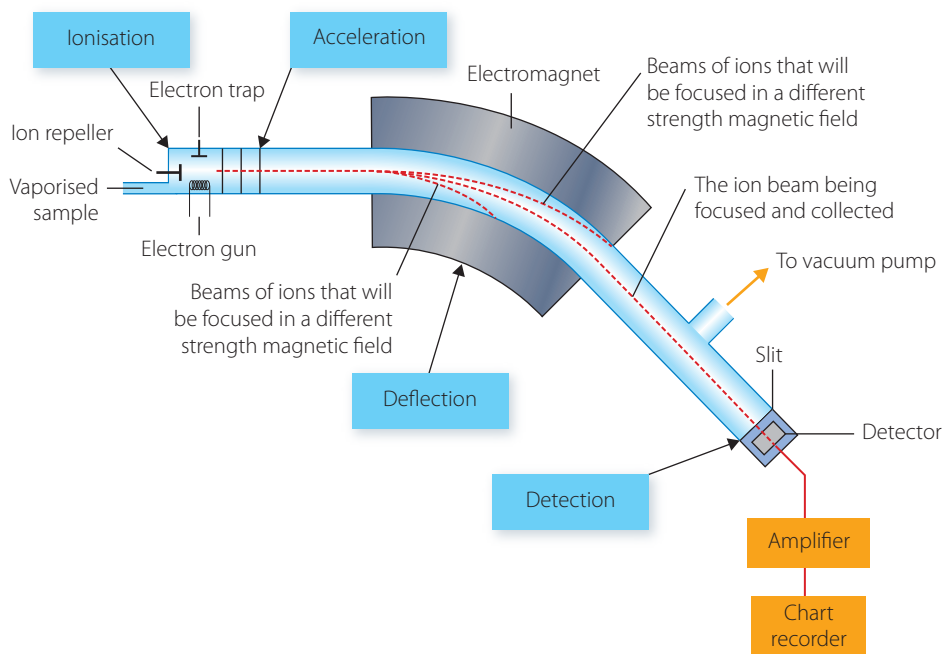
## 15.3 Mass spectroscopy

Mass spectrometry can tell chemists a lot about the structure of a substance, such as the molar mass ( $M$ ) and elements present, and it can detect the **isotopes** of an element. Mass spectrometry has many uses, from radioactively dating fossils to detecting drugs in sport supplements. Mass spectrometers are found in many locations, including on satellites, where they can identify particles carried by the solar wind. An advantage of mass spectrometry is that it only requires a small amount of material but offers a wealth of information.



## Principles of mass spectrometry

The mass spectrometer consists of an ionisation chamber, a path along which the particles travel and a detector, as shown in Figure 15.3.



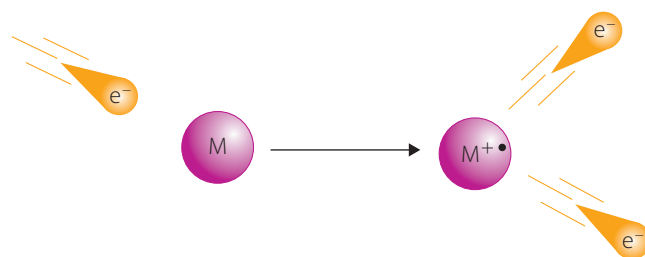
**FIGURE 15.3** The mass spectrometer – a schematic diagram

A vaporised sample is injected into the ionisation chamber where it is bombarded with high-energy electrons that can knock an electron off the molecule or atom. The resultant particle is positively charged and is called a **molecular ion**. Usually only one electron is knocked off, so the charge is typically +1. If more than one electron is knocked off, then the charge corresponds to the number of electrons removed. In the original molecule, every electron was paired, so when an electron is knocked off, the resulting molecular ion has an unpaired electron. This molecule is called a **radical** and is represented by  $\cdot$ . (as can be seen in Figure 15.4.)

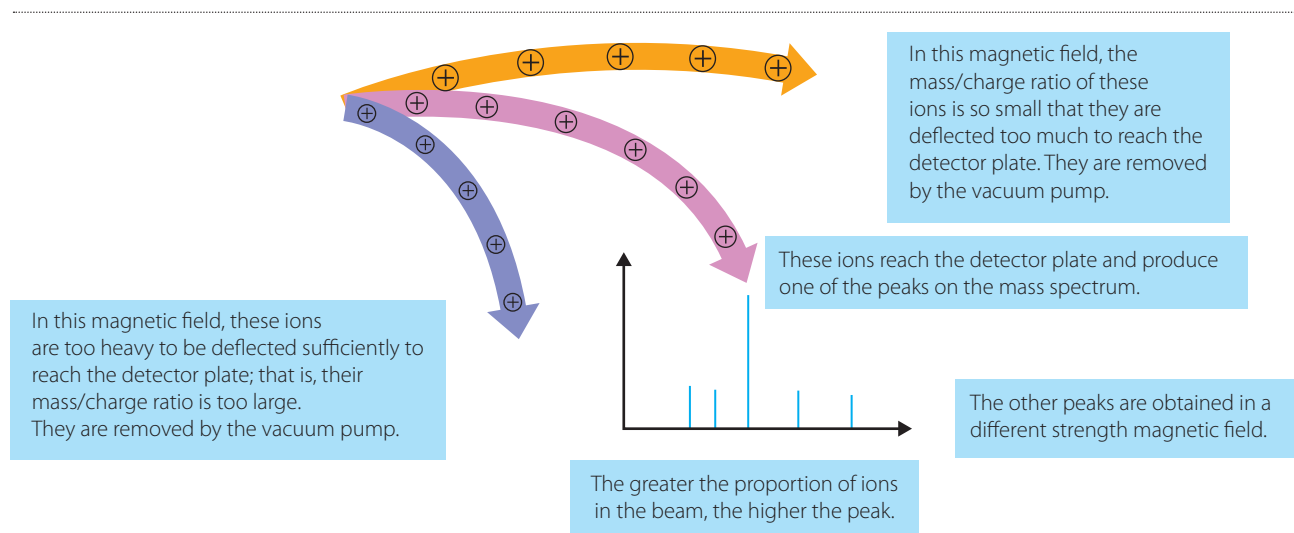
For example:  $\text{CH}_4 + \text{e}^- \rightarrow \text{CH}_4^{\cdot+} + 2\text{e}^-$

These positive particles are accelerated along the path by an electrical field. They then pass through a magnetic field, which deflects the ions based upon mass ( $m$ ) and charge ( $z$ ). Smaller, higher charged particles are easier to deflect. By varying the strength of the magnetic field, the ions can be separated by their mass and collected by a detector. The intensity of the ion beam hitting the detector provides a measure of abundance. The results are presented as a mass spectrum: a plot of mass/charge ratio ( $m/z$ ) versus abundance. Only cations are detected.

This process is shown diagrammatically in Figure 15.5 on page 456.



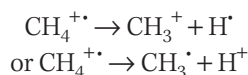
**FIGURE 15.4** Formation of a positive ion by electron bombardment: M represents an atom or a molecule.



**FIGURE 15.5** Focusing and collecting an ion stream

The firing of high-energy electrons onto an organic molecule can cause the molecule to fragment. The initial molecular cation can break to form a smaller cation and a free radical. A free radical still has an unpaired valence electron and is very reactive. The free radical is neutral and uncharged, so it is not detected by mass spectrometry.

The initial molecular, free radical cation of methane can fragment in a mass spectrometer, as shown:

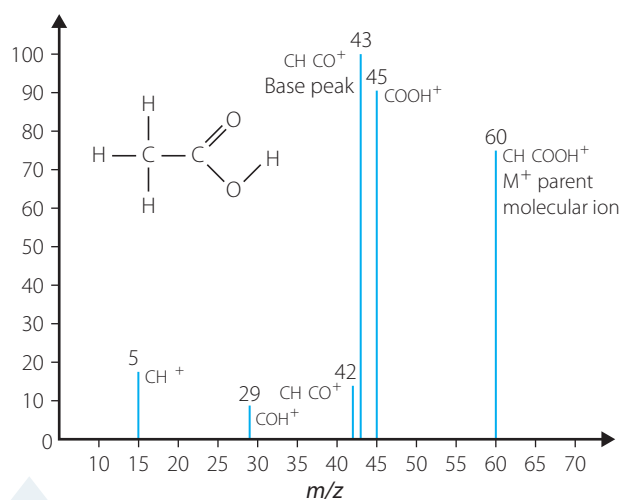


In these cases, only the  $\text{CH}_3^+$  and the  $\text{H}^+$  would be detected by mass spectrometry.

## Interpreting mass spectra

The plot produced by a mass spectrograph is called a mass spectrum, and has a series of lines at different  $m/z$  (mass/charge) values along the  $x$  axis. A cation will be detected at the point that corresponds to the mass of the particle, which is the **atomic mass unit (amu)**. The height of the peak corresponds to the abundance of the species. The most abundant peak on the spectrum is called the **base peak** and it is given a relative abundance of 100 per cent. The other peaks are plotted as a relative percentage to the base peak. Therefore, mass spectra have a percentage scale on the  $y$  axis.

The most important peak on the mass spectrum is the molecular ion ( $\text{M}^{+\bullet}$ ) or **parent molecular ion**, as shown in Figure 15.6. This molecular ion gives the molar mass of the original compound. It should also be noted that the parent molecular ion peak may not be the base peak.

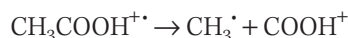


**FIGURE 15.6** Simplified mass spectrum of ethanoic acid ( $\text{CH}_3\text{COOH}$ ). Parent ion and base peak are identified.

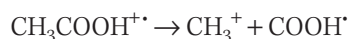
## Fragmentation pattern

Organic molecule fragmentations provide clues to the structure of the molecule. When ethanoic acid ( $C_2H_4O_2$ ) is injected into the mass spectrometer, a range of peaks is observed. Notice that the parent molecular ion at  $m/z$  60 peak is not the most common peak. The most abundant peak is the base peak at  $m/z$  43. The other common peaks present are at  $m/z$  45 and 15.

The parent ion ( $C_2H_4O_2$ ) has many different possibilities for fragmentation. This fragmentation is shown in Figure 15.7. If the bond between the two carbons breaks, then there are two possible peaks: a peak corresponding to the cation  $CH_3^+$  at an  $m/z$  value of 15 and a peak corresponding to  $COOH^+$  at an  $m/z$  value of 45. Notice in Figure 15.6 that the peak at 45 is much bigger than the peak at 15. This indicates that the fragmentation:



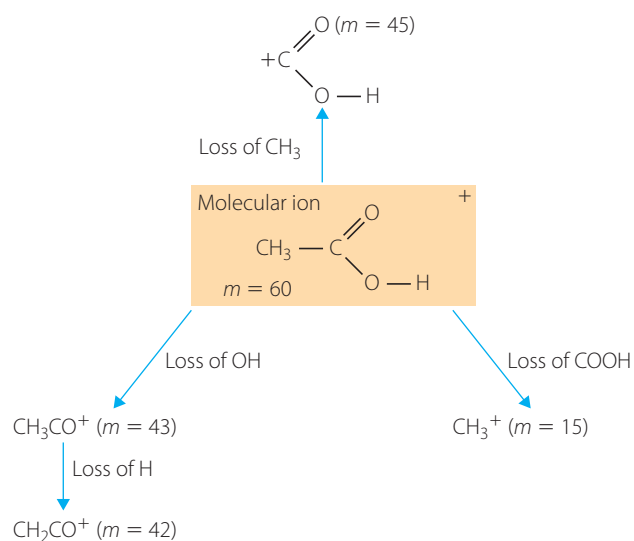
is more common than



Remember that neutral species are not detected by mass spectroscopy.

In mass spectroscopy, you can look at the peaks on the mass spectra. A peak at 15 indicates a  $CH_3^+$  and would indicate that the methyl group (molecular mass 15) is present in the parent molecule. Common fragmentations are listed in Table 15.4.

Alternatively, you can look at the differences in peak values. The **parent peak** has a value at 60 and there is a peak at 45. This difference of 15 could indicate loss of a methyl group. The peak at 43 is 17 less than the parent peak. This could indicate loss of an  $-OH$  group. A loss of a H atom could explain a peak at  $m/z$  59.



**FIGURE 15.7** Simplified fragmentation pattern of molecular ion  $CH_3COOH^+$

**TABLE 15.4** Common fragmentations that occur in organic molecules

RELATIVE MASS	FRAGMENT
15	$CH_3$
17	$OH$
18	$H_2O$
29	$CH_2CH_3, CHO$
31	$OCH_3$
45	$COOH, OCH_2CH_3$

The mass spectrum shown in Figure 15.6 is a relatively simple one. As the number of atoms in molecules increase, their spectra become more complex since there is increasing fragmentation. As a result, compounds have unique spectra. Chemists have developed databanks of spectrum for thousands of compounds, and they use these to assist in the identification of unknown compounds.



General  
fragmentation  
patterns

## Isotopes and mass spectra

The main elements – carbon, hydrogen and oxygen – that make up organic compounds also have isotopes, as shown in Table 15.5.

**TABLE 15.5** The isotopic composition of carbon, hydrogen and oxygen

ELEMENT	ISOTOPE	RELATIVE ISOTOPIIC MASS	ABUNDANCE (%)
Hydrogen	$^1\text{H}$	1.0078	99.99
	$^2\text{H}$	2.0141	~0.01
	$^3\text{H}$	3.0160	<<0.02
Carbon	$^{12}\text{C}$	12.000	98.93
	$^{13}\text{C}$	13.003	1.07
	$^{14}\text{C}$	14.003	~ $10^{-10}$
Oxygen	$^{16}\text{O}$	15.995	99.757
	$^{17}\text{O}$	16.999	0.038
	$^{18}\text{O}$	17.999	0.205



Isotopes  
and mass  
spectrometry

Because mass spectra produce peaks based on the mass of the molecule and its fragments, the presence of isotopes of the elements means there may also be peaks for isotopic variations of the molecules. However, as can be seen in Table 15.5, the abundance of some isotopes is very small, so if there are additional peaks they will usually be small and can be ignored.

If only one element is being examined using mass spectroscopy, the different peaks will only be due to the presence of isotopes of that element. The position of the peaks indicates the relative isotopic mass and the height of the peaks indicates the relative abundance of each isotope. This means mass spectroscopy can also be used for identifying the presence of the isotopes of an element.

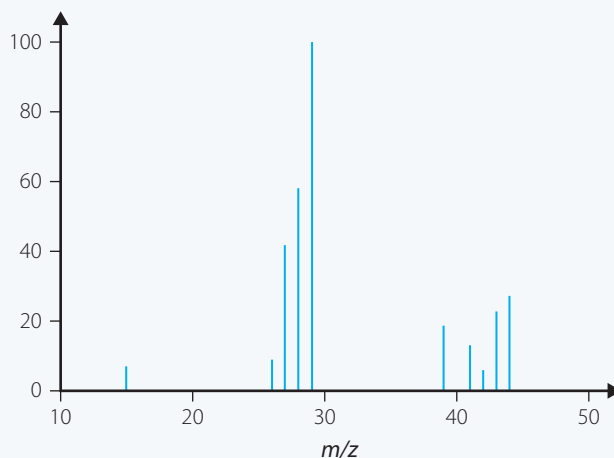
However, this section will only focus on using mass spectrometry to identify organic compounds.

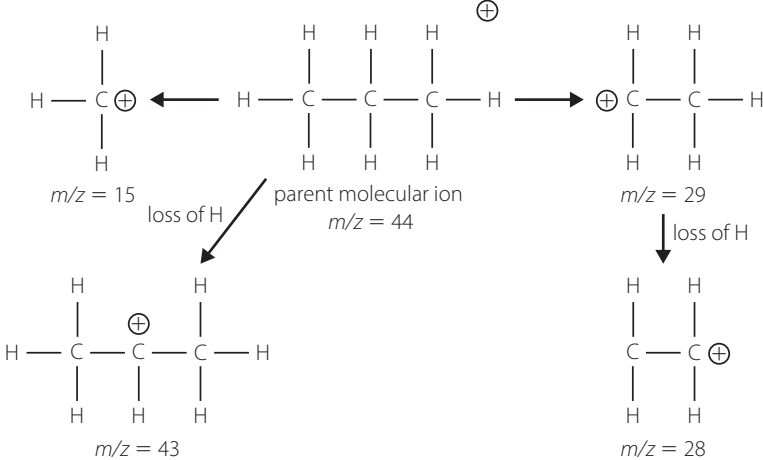
### WORKED EXAMPLE (15.1)

The mass spectrum shown in this figure is of an unknown substance. Chemical testing has identified the compound as an alkane.

- 1 Identify the alkane.
- 2 Account for the peaks at 15, 28, 29 and 43.

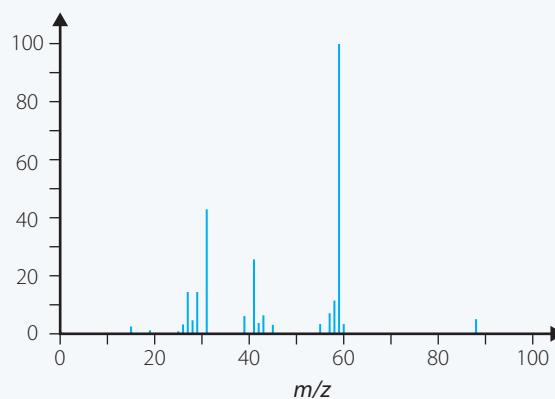
Mass spectrum of an unknown substance



ANSWER	LOGIC
<p><b>1</b> Largest mass is 44.</p> <p>C = 12, H = 1 Try C<sub>3</sub>H<sub>8</sub> 12 × 3 + 1 × 8 = 44 Parent molecular ion is propane.</p>	<ul style="list-style-type: none"> <li>Identify the largest mass, since this will be the parent molecular ion.</li> <li>Use the general formula of alkanes (C<sub>n</sub>H<sub>2n+2</sub>) to calculate an alkane that has a mass of 44.</li> </ul>
<p>Propane</p>	<ul style="list-style-type: none"> <li>Express the answer.</li> </ul>
<p><b>2</b> 15 = CH<sub>3</sub><sup>+</sup> 29 = CH<sub>2</sub>CH<sub>3</sub><sup>+</sup></p>	<ul style="list-style-type: none"> <li>Use Table 15.4 to identify possible common fragments.</li> </ul>
 <p>Diagram illustrating the fragmentation of propane (C<sub>3</sub>H<sub>8</sub>) into fragments. The parent molecular ion (m/z = 44) is shown as a three-carbon chain with a positive charge on the middle carbon. Arrows indicate the loss of hydrogen atoms to form fragments: m/z = 15 (CH<sub>3</sub><sup>+</sup>), m/z = 29 (CH<sub>2</sub>CH<sub>3</sub><sup>+</sup>), m/z = 43 (CH<sub>3</sub>CH<sub>2</sub><sup>+</sup>), and m/z = 28 (CH<sub>2</sub>CH<sub>2</sub><sup>+</sup>).</p>	<ul style="list-style-type: none"> <li>Draw a structural diagram of the parent molecular ion and possible fragments.</li> </ul>
<p>15 = CH<sub>3</sub><sup>+</sup>, 28 = CH<sub>2</sub>CH<sub>2</sub><sup>+</sup>, 29 = CH<sub>2</sub>CH<sub>3</sub><sup>+</sup>, 43 = CH<sub>3</sub>CHCH<sub>3</sub><sup>+</sup></p>	<ul style="list-style-type: none"> <li>Calculate the mass of fragments, remembering a difference of 1 means a loss of H.</li> <li>Express the answer.</li> </ul>

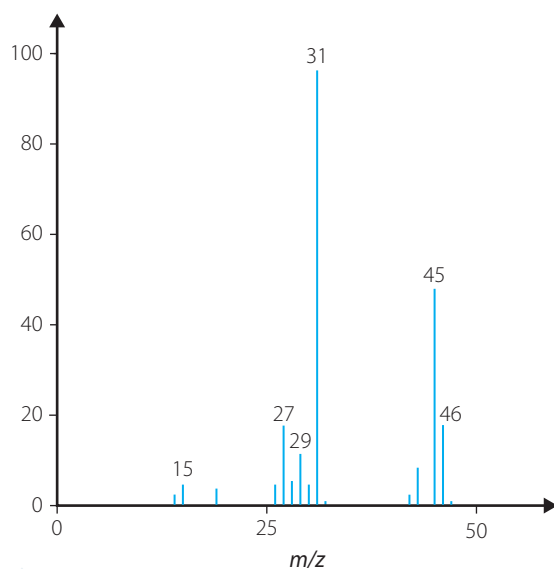
### TRY THESE YOURSELF

- The mass spectrum of hexane shows strong peaks at *m/z* values of 15, 29, 41, 43 and 57. Identify the possible fragments at these values.
- The figure here shows the mass spectrum of 3-pentanol.
  - Account for the peaks at 31, 41 and 59. (**Hint:** The peaks at 31 and 41 are due to fragmentation of the species at 59.)
  - The mass spectrum of 1-pentanol has peaks at 31 and 57, but no peak at 59. Suggest what this fragment might be and why the fragmentation is different for the two isomers.



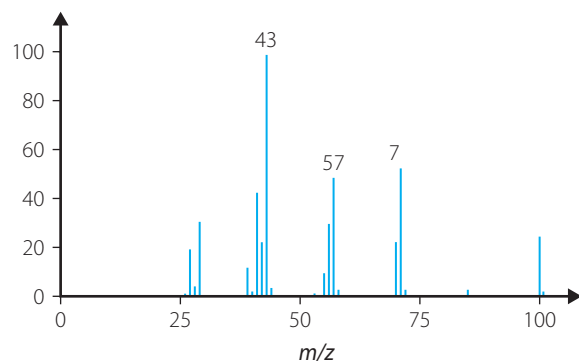
- Mass spectrometry is a technique that produces cations, which are separated according to their mass/charge ratio (*m/z*), and measures their relative abundance.

- State the meaning of:
  - mass/charge ratio
  - base peak.
- Draw a simple schematic diagram of a mass spectrometer. Label it to show what happens in each part of the instrument.
- Which peak in a mass spectrum indicates the molecular mass of the compound?
- When can you get a peak with an  $m/z$  value greater than that of the parent molecular ion?
- Why are only cations detected in mass spectroscopy?
- Explain how a mass spectrum can be used to help determine the structure of a compound.
- Figure 15.8 shows the mass spectrum of ethanol.
  - Account for the peaks at 15, 29, 45 and 46.
  - What can be concluded about the peak at 31? Justify your answer.



**FIGURE 15.8** Mass spectrum of ethanol

- Figure 15.9 shows the mass spectrum for  $C_7H_{16}$ . Account for the main peaks in the spectrum.



**FIGURE 15.9** Mass spectrum for  $C_7H_{16}$



9 There was concern at a bioethanol plant that the ethanol had become contaminated with methanol. To check this, a chemist tested a sample and obtained the following mass spectrum for the sample (Figure 15.10). Compare the spectrum of the contaminated sample with that of ethanol in Figure 15.8.

- Explain how the chemist determined the sample was contaminated.
- Justify that the contaminant was methanol.

10 The chemical composition of compound X was found to be  $C_5H_{10}O$ . The two possible structural isomers are shown in Figure 15.11.

- What mass/charge ratio ( $m/z$ ) would you expect for the parent ion for each isomer?
- The base peak for structure A (Figure 15.11a) occurs at a mass/charge ratio of 43, whereas the mass spectrum for structure B (Figure 15.11b) occurs at a mass/charge ratio of 57. Account for these two peaks.
- The mass spectrum of compound X was found to not have a peak at 29. How does this enable the structure of compound X to be determined?

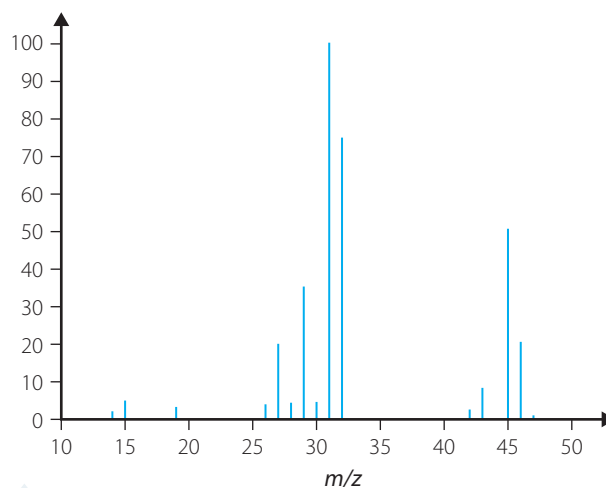


FIGURE 15.10 Mass spectrum of contaminated sample

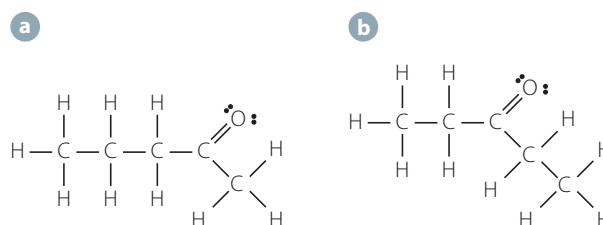


FIGURE 15.11 Possible structures for compound X

## 15.4 NMR spectroscopy

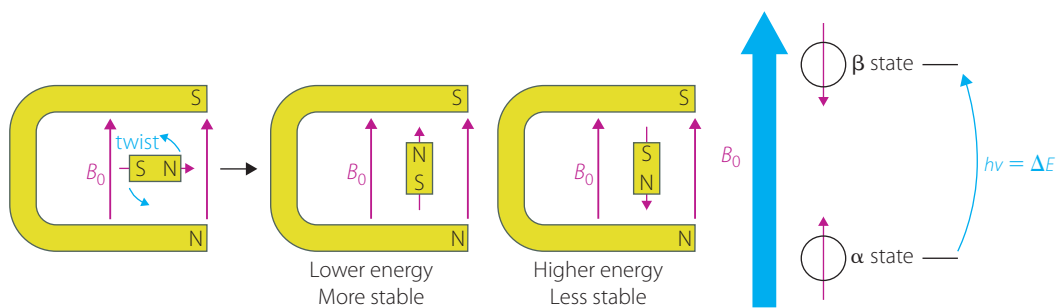
One of the most important and powerful techniques used to determine the structures of molecules is nuclear magnetic resonance (NMR). In 1991, the Nobel Prize in Chemistry was awarded to Richard Ernst. He developed the most powerful tool for the determination of the structure of organic and inorganic compounds, and biological macromolecules in solution. It relies on the behaviour of nuclei when placed into a magnetic field. It has been likened to the nuclei playing their own faint, magnetic melody. The atoms are identified by a characteristic melody that they emit. Ernst's trick was to make this music audible; he allowed chemists to pinpoint the exact location of nuclei within hundreds of others in complex molecules.

### Principles of NMR spectroscopy

When matter is placed in a magnetic field, some nuclei act like microscopic magnetic compass needles. The charged nuclei spin and create small magnetic fields. Only nuclei with an odd number of **nucleons** (protons and neutrons) possess spin that creates the magnetic field. The most common nuclei studied are  $^1\text{H}$  and  $^{13}\text{C}$ . These nuclei are used to produce  $^1\text{H}$  spectra and  $^{13}\text{C}$  spectra. Just like iron filings near a magnet, most nuclei align with the field. This is the lower energy state.

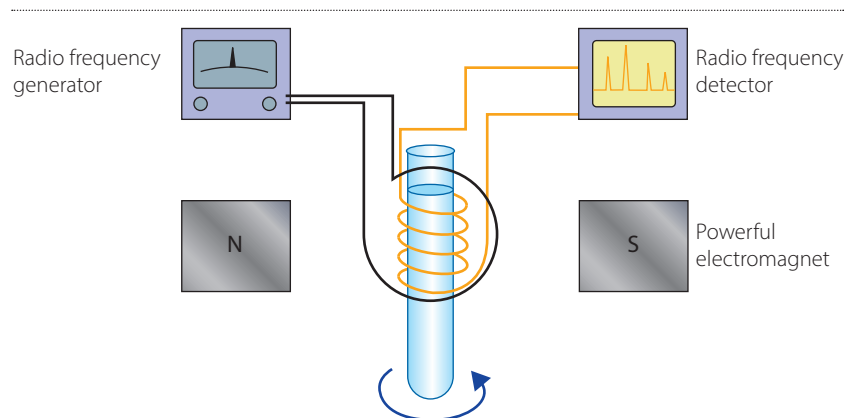
Nuclei aligned with the field can absorb the energy of the radio wave and flip to a higher energy spin (not aligned) when the radio waves have the exact frequency that matches the resonance of the nuclei (Figure 15.12). Just as an electron moves from an excited state to a ground state and emits energy, the nuclei will flip back to the more stable lower energy state and emit energy. The energy difference between these aligned and unaligned spins depends upon the nature of the nuclei and chemical environment of the nuclei.





**FIGURE 15.12** Hydrogen-1 and carbon-13 nuclei in an external field act like small magnets. Nuclei aligned with the field have less energy and are more stable. The nuclei aligned against the field have higher energy and are less stable.

The NMR spectrometer consists of a large magnet, a sample holder, a source of radio waves and a detector, as shown in Figure 15.13. The sample is placed into the magnetic field. The sample will be irradiated with a range of different frequencies of radio waves. A number of these frequencies will be absorbed as particular nuclei flip. The detector records the energy waves emitted when the nuclear spin returns to the lower energy state. This produces NMR spectra that show series of lines correlating to the type and the environment of the nuclei.



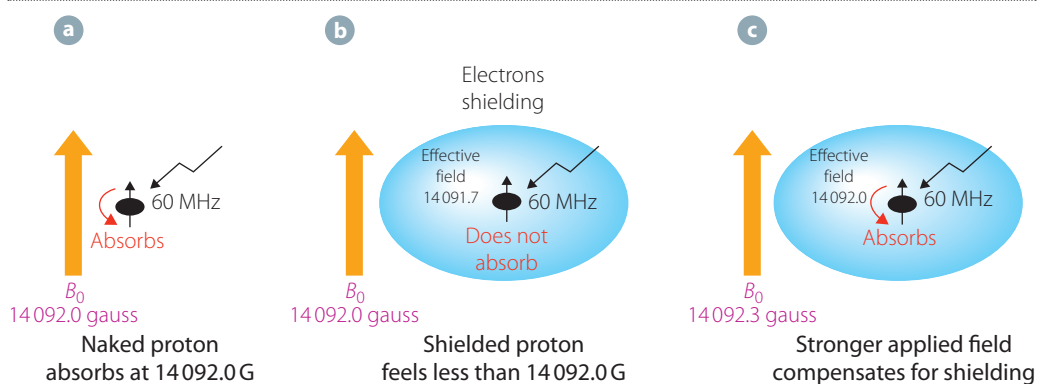
**FIGURE 15.13** A simplified NMR spectrometer

## Chemical environment

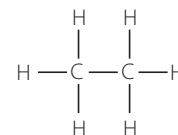
The energy required to flip the nucleus indicates the chemical environment of the nucleus. When protons are in an identical environment, they will absorb the same frequency and produce one peak.

Electrons are also spinning charged particles and produce a small magnetic field. The electron clouds close to the nuclei can **shield** the proton from the effect of the field. Shielded nuclei would require higher energy to be flipped, as shown in Figure 15.14.

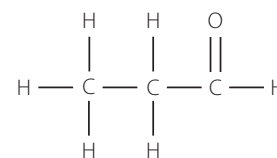
Each atom involved in a chemical bond shares electrons. Polarity is an important factor in the chemical environment of the nuclei since it affects the sharing of the electrons. Nuclei are in the same environment when they are bonded to the same group of atoms in the same way. If all nuclei were in the same chemical environment, you would not get much information. When the bonding of nuclei is different, the chemical environment is different. This means that for each different nucleus, a different frequency will be absorbed (and then emitted), producing a different line on the spectrum.



**FIGURE 15.14** **a** A naked proton will absorb the energy from the radio waves and flip to the higher energy state. **b** The presence of electrons will shield the proton. The same amount of energy will not be sufficient to flip the proton to the higher energy state. **c** A stronger field is now required to compensate for the shielding and to cause the proton to flip.



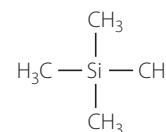
For example, in ethane, each carbon atom is attached to another carbon as well as to three hydrogen atoms. Both the carbon atoms have the same chemical environment, as do all six hydrogen atoms, so the  $^1\text{H}$  spectrum would have only one line, as would the  $^{13}\text{C}$  spectrum. However, in the aldehyde propanal, there are three different carbon environments and three different H environments. Therefore, both the  $^1\text{H}$  spectrum and the  $^{13}\text{C}$  spectrum will each have three lines.



## Chemical shift

NMR frequencies depend on the strength of the magnetic field and, hence, the spectrometer being used. For comparison, it is more convenient to use a scale that is independent of the magnetic field. To do this, the difference from an agreed reference is measured. This difference is divided by the absorption frequency of the reference, to produce a value called the **chemical shift,  $\delta$  (delta)**. This chemical shift, measured in parts per million (ppm), is independent of the magnetic field and, hence, can be used for comparing spectra from any magnetic field.

The most shielded compound is  $\text{Si}(\text{CH}_3)_4$ , called **tetramethylsilane (TMS)** (Figure 15.15). Silicon is less electronegative than carbon so the bonding electrons will spend more time around the hydrogen nuclei. In this compound, the 4 C atoms are in the same chemical environment and the 12 H atoms in the same chemical environment, so give a strong signal. TMS is used as the zero and is the calibration peak generally shown on the right in every spectrum. Since every other compound will be less shielded than TMS, their values will always appear to the left of TMS.



**FIGURE 15.15** Tetramethylsilane (TMS) is the standard used in NMR spectroscopy.

The chemical shift has the same value regardless of the strength of the field. So a type of nucleus in a 60, 100 or 300 MHz NMR spectrometer will have the same chemical shift.

## Solution

Molecular structure can be determined in solution.  $^1\text{H}$  are very common, so the signal of the compound being studied must be isolated from the signal of the solvent being used. Chemists use a solvent that has no magnetic dipole moment, which would be due to protons and neutrons cancelling out. The use of an alternative isotope of hydrogen,  $^2\text{H}$  or deuterium (D), to make solvents such as  $\text{D}_2\text{O}$  (10 protons, 10 neutrons) and  $\text{CD}_2\text{Cl}_2$  (42 protons, 42 neutrons) produces a solvent invisible to the NMR spectrometer.

## Interpreting NMR spectra

NMR spectroscopy is used to determine the structure of an organic compound and is able to distinguish between isomers. When a compound is irradiated with radio waves of different frequencies, a number of different frequencies will be absorbed. When these frequencies are emitted, they will produce a number of peaks on the spectrum. The spectrum produced shows the calibration peak (at zero) and a series of lines along the horizontal scale labelled chemical shift.

Tables like Table 15.6 (for  $^1\text{H}$  spectra) and Table 15.7 (for  $^{13}\text{C}$  spectra) are used when interpreting NMR spectra.

**TABLE 15.6** Typical protons shifts values relative to TMS = 0. The solvent used may produce slightly different values, so these are a guide only. Where more than one proton environment is shown in the formula, the shift refers to the protons in bold letters. Ar = aromatic group.

TYPE OF PROTON	CHEMICAL SHIFT (ppm)	TYPE OF PROTON	CHEMICAL SHIFT (ppm)
Alkane $\text{CH}_3$	0.9	$\text{R}-\text{NH}_2$ $\text{RCH}=\text{CH}_2$	Variable, about 1.5–4 4.6–6.0
$\text{R}-\text{CH}_2-\text{R}$	1.3	$\text{R}-\text{O}-\text{CH}_3$ or $\text{ROCH}_2\text{R}$	3.3
$\text{R}-\text{C}=\text{OCH}_3$	2.1	$\text{R}-\text{OH}$	Variable, about 1–6
$\text{R}-\text{CH}_2-\text{X}$ (X = F, Cl, Br or I)	3–4	Ar—OH	Variable, about 4–7
$\text{CH}_3-\text{COOR}$	2.0	$\text{R}-\text{COOH}$	9–13
$\text{RCH}_2\text{OH}$ $\text{RCH}=\text{CH}-\text{CH}_3$	3.3–4.5 1.6–1.9	$\text{R}-\text{C}(\text{O})\text{H}$	9–10

**TABLE 15.7** Typical  $^{13}\text{C}$  NMR carbon shifts values relative to TMS = 0. The solvent used may produce slightly different values, so these are a guide only.

TYPE OF CARBON	CHEMICAL SHIFT (ppm)
$\text{R}-\text{CH}_3$	8–25
$\text{R}-\text{CH}_2-\text{R}$	20–45
$\text{R}_3-\text{CH}$	40–60
$\text{R}_4-\text{C}$	36–45
$\text{RCH}_2-\text{X}$	15–80
$\text{RCNH}_2$	35–70
$\text{RCH}_2-\text{O}$	50–90
$\text{RC}=\text{CR}$	110–150
$\text{RCOOH}$	160–185
$\text{RC}(\text{O})\text{H}$ (aldehydes)	190–200
$\text{RC}=\text{O}$ (in ketones)	205–220

In NMR spectroscopy, the  $^1\text{H}$  or proton refers to the hydrogen nuclei. The bonding electrons are still orbiting the nucleus. They provide the shielding. It is not referring to the  $\text{H}^+$  ion. It is in acid–base reactions that the proton transferred is the  $\text{H}^+$  ion.

## Low-resolution $^1\text{H}$ NMR spectroscopy

Low-resolution  $^1\text{H}$  NMR spectroscopy is the most common instrumental technique used. The  $^1\text{H}$  (or proton) is abundant and hydrogen is usually very common in organic molecules. Low-resolution NMR spectroscopy can determine the chemical environment of the nuclei (such as an  $-\text{OH}$  or a  $-\text{CH}_2-$ ), the number of these environments and the number of protons in each environment.

## Number of peaks

The number of peaks shows how many different kinds of chemical environments are present. If the protons are in the same environment, they will produce a peak with the same shift and so are seen as one peak.

As mentioned earlier, due to the symmetry of the ethane molecule, all the hydrogen atoms are in the same chemical environment so the  $^1\text{H}$  spectrum, shown in Figure 15.16, has only one peak.

From Figure 15.17, you can see that there are four H atoms in ethanoic acid ( $\text{CH}_3\text{COOH}$ ). Three are attached to the same carbon, forming a methyl group and one is attached to the oxygen, forming the hydroxyl group. There are two hydrogen environments, so there are two peaks in the spectrum.

## Location of the peaks

The *location* of the signal shows how shielded or deshielded the proton is. The list of typical proton shifts, as shown in Table 15.6, can be valuable for determining the types of protons present.

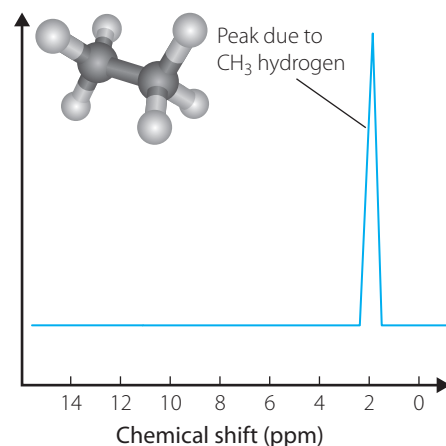
For ethane (Figure 15.16), the spectrum shows a peak less than 1 ppm. This is caused by the hydrogen protons ( $^1\text{H}$ ) in the methyl group. The protons are all attached to a carbon and are still relatively shielded but are still downfield from TMS.

In ethanoic acid, a peak is present at about 2 ppm for the protons in the methyl group. Next to this methyl group is a carbon with two oxygens attached. When oxygen is attached to the carbon, it attracts the electrons and the nuclei are less shielded. It takes less energy to flip the nuclei. So the methyl protons are slightly further downfield than those in ethane.

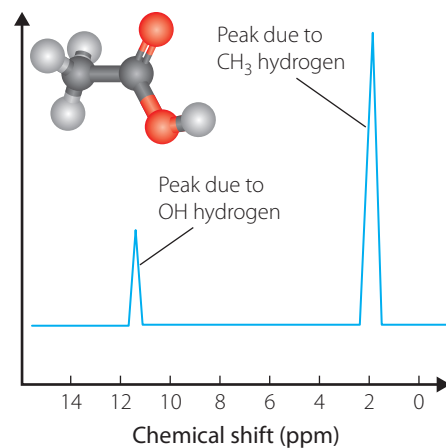
In an ethanoic acid spectrum, there is a peak near 12 ppm. This is due to the proton in the  $-\text{COOH}$  group of the carboxylic acid. The two oxygens are both deshielding the H proton, which has resulted in a large chemical shift.

## Intensity of the signal

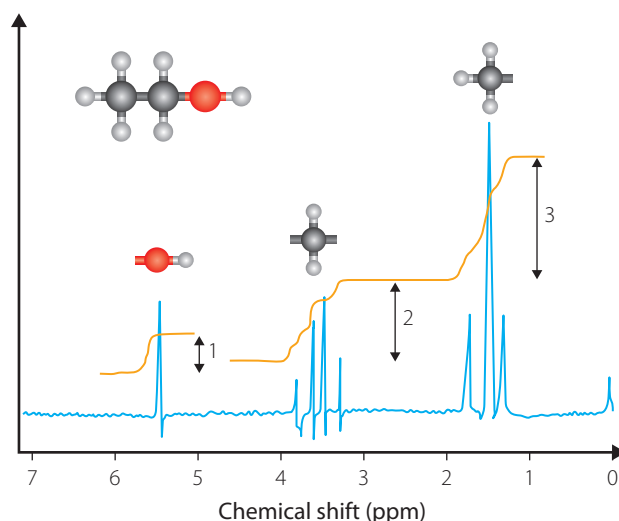
The *intensity* of the signal shows the number of protons of that type. The area under the peak is proportional to the number of hydrogens in that environment. When the peak's bases are similar, the height of the peaks can be used as a ratio to calculate the number of protons in each environment. For ethane, there is only one peak. For ethanoic acid, there are two peaks with a ratio of 3:1. The peak corresponding to three protons in the methyl group has a peak area of 3 compared to the single proton on the  $-\text{OH}$  group. For ethanol, there are three peaks with a relative intensity of 3:2:1, as shown in Figure 15.18.



**FIGURE 15.16** The low-resolution  $^1\text{H}$  NMR spectrum of ethane ( $\text{CH}_3\text{CH}_3$ )



**FIGURE 15.17** The low-resolution  $^1\text{H}$  NMR spectrum of ethanoic acid (simplified)

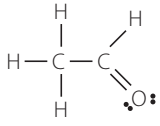


**FIGURE 15.18** The high-resolution  $^1\text{H}$  NMR spectrum of ethanol with the integration showing the ratio of the number of protons for each environment

## WORKED EXAMPLE (15.2)

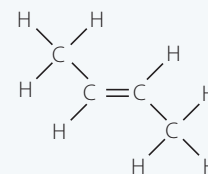
Consider the molecule  $\text{CH}_3\text{COH}$ . Determine the:

- 1 number of H environments
- 2 relative intensity of the peaks
- 3 expected chemical shifts.

ANSWER	LOGIC
	<ul style="list-style-type: none"> <li>▪ Draw the structure.</li> </ul>
<ol style="list-style-type: none"> <li>1 There are two H environments.</li> <li>2 Relative intensity of the peaks is 3:1.</li> </ol>	<ul style="list-style-type: none"> <li>▪ Count the number of hydrogens on different atoms – check for symmetry.</li> <li>▪ There are two H environments in a ratio of 3:1.</li> </ul>
<ol style="list-style-type: none"> <li>3 <math>\text{CH}_3 = 0.9\text{ppm}</math>, <math>\text{C(O)H} = 9\text{--}10\text{ppm}</math></li> </ol>	<ul style="list-style-type: none"> <li>▪ From Table 15.6, the methyl would have a chemical shift near 0.9ppm and the C(O)H group would be in the range of 9–10ppm.</li> </ul>

### TRY THESE YOURSELF

- 1 Determine the number of hydrogen environments and chemical shift for 1-butanol.
- 2 Determine the number of hydrogen environments and chemical shift for the molecule seen here on the right.



## High-resolution $^1\text{H}$ NMR spectroscopy

High-resolution  $^1\text{H}$  NMR spectroscopy can provide one additional piece of evidence compared to low-resolution  $^1\text{H}$  NMR spectroscopy when determining the structure. The extra detail in the spectra shows the signal **splitting** into clusters of peaks. The splitting pattern shows the number of protons on adjacent atoms.

### Neighbours: $n + 1$ rule

In  $^1\text{H}$  NMR spectra, there is one more peak than there are hydrogens attached to the next atoms, the **neighbouring atoms**. In low-resolution  $^1\text{H}$  NMR spectroscopy, a methyl group will have a chemical shift around 0.9ppm, an integrated value of three and appear as a single line. In high-resolution  $^1\text{H}$  NMR spectroscopy, the chemical shift and intensity will be the same but this peak may appear split. The common patterns observed are a doublet (two equal signals), a triplet (a set of three signals in the ratio of 1:2:1) and a quartet (a set of four signals in the ratio of 1:3:3:1). To work out the pattern, you have to count the number of protons (hydrogen atoms) on the adjacent atoms. The number of peaks can be calculated by using the  $n + 1$  rule, where  $n$  refers to the number of protons on the adjacent atoms.

For example: Ethanol has a methyl group that will split into a triplet due to the  $-\text{CH}_2-$  group attached to the next carbon ( $2(\text{H}) + 1 = 3$ ). The  $-\text{CH}_2-$  group will split into a quartet due to the methyl group ( $3(\text{H}) + 1 = 4$ ). However, the peak due to the  $-\text{OH}$  group will remain a singlet despite two protons on the neighbouring carbon. This is shown in Figure 15.18

The splitting of the signal is due to **spin-spin coupling** with the neighbouring non-equivalent protons. The protons on the next carbon can be aligned with the proton (H atom) in the environment you are looking at and provide extra shielding. Or the neighbouring protons may align against the field and deshield or shift the peak downfield. For one neighbouring proton, there are two possibilities: one with and one against (Figure 15.19). When there are two neighbouring protons, there are three possibilities: two protons aligned with, two against and one with and one against (Figure 15.20). Pascal's triangle can be used to determine the number and relative intensities of the peaks (Figure 15.21).



**FIGURE 15.19**  
For one neighbouring proton, there are two possibilities: one aligned with and one aligned against.

WS  
Unique environments in NMR spectroscopy

**TABLE 15.8** Splitting pattern observed in high-resolution NMR

NEIGHBOURING PROTONS	PATTERN		$n + 1 =$
0	Signal is not split	Singlet	1
1	Signal splits into two	Doublet	1:1
2	Signal splits into three	Triplet	1:2:1
3	Signal splits into four	Quartet	1:3:3:1
4 or more		Multiplet	

## No splitting

There are a couple of times when you do not get signal splitting. This occurs when the neighbouring nuclei has the same chemical shift or the proton belongs to an —OH group. There is no interaction between the H on the —OH group with any H on the neighbouring carbon. The proton does not cause splitting and never splits. The —OH group may vary its chemical shift depending on the conditions that the spectra have taken but it is always a singlet.

## <sup>13</sup>C NMR spectroscopy

The <sup>13</sup>C isotope is only about 1 per cent in abundance compared to the <sup>12</sup>C isotope. As such, <sup>13</sup>C NMR spectra take much longer and do not provide the same details as the <sup>1</sup>H NMR spectra.

## Number of peaks

<sup>13</sup>C NMR spectra will indicate the number of different carbon environments by the number of different peaks observed. The type of carbon is indicated by the chemical shift of the peak. Due to peculiarities of the technique, the height does *not* relate to the number of carbons in each environment, nor is splitting observed. The spectra are much simpler than those of <sup>1</sup>H.

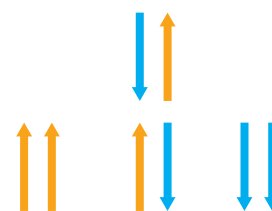
From Figure 15.22, it can be seen that there are two carbon atoms in the ethanol molecule. One is attached to three hydrogen atoms, forming a methyl group, and one is attached to two hydrogen atoms and the oxygen forming the hydroxyl group. There are two carbon environments so there should be two peaks in the spectrum. This can be seen in Figure 15.23.

## Location of the peaks

As for the <sup>1</sup>H spectra, the *location* of the signal shows how shielded or deshielded the carbon nucleus is based on the shift from the TMS zero. The list of typical proton shifts, as shown in Table 15.7, can be valuable for determining the types of nuclei present.

For ethanol (Figure 15.23), the spectrum shows a peak just less than 20 ppm. According to Table 15.7 this is caused by the carbon atom in the methyl group (8–25 ppm shift).

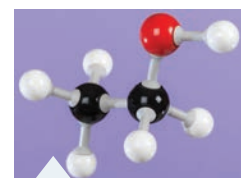
Next to this methyl group is a carbon with one oxygen attached. When oxygen is attached to the carbon, the oxygen attracts the electrons and the nuclei are less shielded. It takes less energy to flip the nuclei. There is a peak around 59 ppm, which according to Table 15.7 (page 465) (RCH<sub>2</sub>—O shift 50–90 ppm) could be due to the —CH<sub>2</sub>OH group.



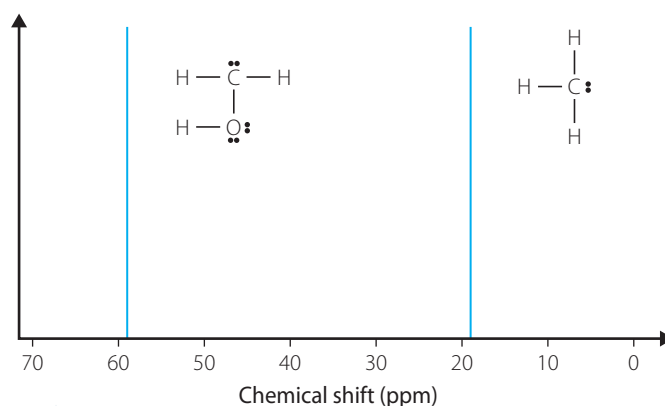
**FIGURE 15.20** For two neighbouring protons, there are three possibilities: two protons aligned with, two against and one with and one against.

1
1 1
1 2 1
1 3 3 1
1 4 6 4 1
1 5 10 10 5 1

**FIGURE 15.21** Pascal's triangle



**FIGURE 15.22** Ball and stick model of ethanol

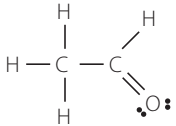


**FIGURE 15.23** <sup>13</sup>C NMR spectrum of ethanol

## WORKED EXAMPLE 15.3

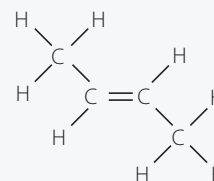
Consider the molecule  $\text{CH}_3\text{CHO}$ . Determine the:

- 1 number of C environments
- 2 expected chemical shifts.

ANSWERS	LOGIC
	<ul style="list-style-type: none"> <li>▪ Draw the structure.</li> </ul>
<b>1</b> There are two C environments.	<ul style="list-style-type: none"> <li>▪ Count the number of C attached to different atoms – check for symmetry.</li> </ul>
<b>2</b> $\text{CH}_3 = 8\text{--}25\text{ ppm}$ , $\text{C(O)H} = 190\text{--}200\text{ ppm}$	<ul style="list-style-type: none"> <li>▪ From Table 15.7, the methyl would have a chemical shift between 8 and 25 ppm and the C(O)H group would be in the range of 190–200 ppm.</li> </ul>

### TRY THESE YOURSELF

- 1 Determine the number of carbon environments and chemical shift for 1-butanol.
- 2 Determine the number of carbon environments and the chemical shift for the molecule seen here on the right.



- The technique of nuclear magnetic resonance spectroscopy is due to nuclei in a magnetic field being forced to 'flip'. Electrons shield the nuclei, which alters the resonance/chemical shift, allowing determination of structure.
- The splitting pattern is observed only in high-resolution  $^1\text{H}$  NMR spectra. The  $(n + 1)$  rule can be used to determine the number of protons on adjacent atoms, the nearest neighbours.
- The number of peaks in an NMR spectrum indicate the number of different chemical environments of the H (proton) and C nuclei.

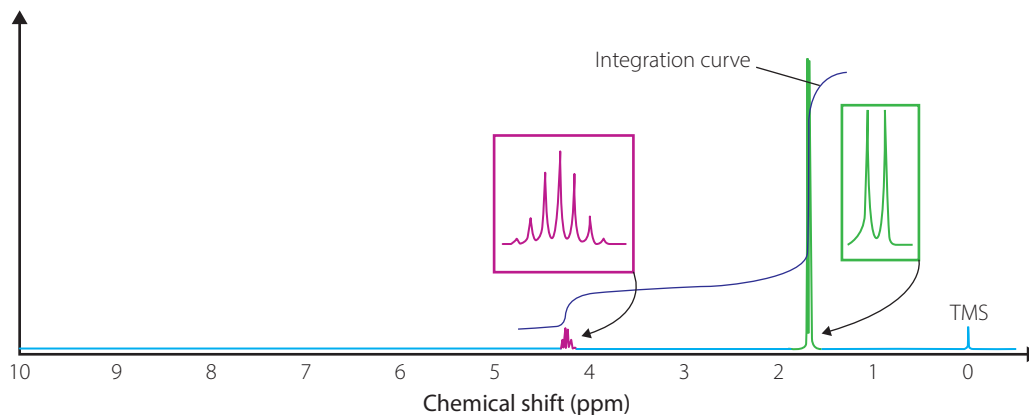
## CHECK YOUR UNDERSTANDING

15.4

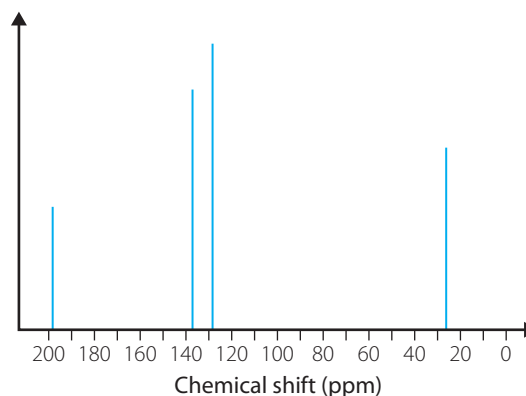
- 1 Which two common isotopes are useful for NMR spectroscopy? Why are these able to be detected by NMR spectroscopy?
- 2 Which part of the electromagnetic spectrum is used by NMR spectroscopy?
- 3 What are four things that can be determined by  $^1\text{H}$  NMR spectroscopy?
- 4 What information does  $^{13}\text{C}$  NMR spectroscopy provide?
- 5 Predict the total number of peaks in the  $^1\text{H}$  NMR and  $^{13}\text{C}$  NMR spectra of the following compounds.
  - a Methane
  - b Ethane
  - c 2-propanol
  - d Butanoic acid
  - e Ethene
  - f 1-butene
  - g 2-butene
  - h 1-chloropentane
  - i 3-chloropentane



- 6 Provide explanations for the following.
- The amount of energy needed for the nuclei to flip from a parallel to antiparallel alignment depends on the chemical environment.
  - The splitting patterns (doublet, triplet, quartet) that occur in  $^1\text{H}$  NMR spectroscopy.
  - Why  $\text{CCl}_4$  is a common solvent for NMR spectroscopy.
- 7 Account for all the peaks in the following  $^1\text{H}$  NMR spectra for  $\text{C}_3\text{H}_7\text{Br}$  shown in the following figure. What groups caused the observed splitting patterns? Determine the structure of the molecule.



- 8 Explain how you could tell the difference between a  $^{13}\text{C}$  NMR spectrum for propanone and one for propanal.
- 9 Identify each of the peaks in the  $^{13}\text{C}$  NMR spectrum of 3-butene-2-one seen here on the right.



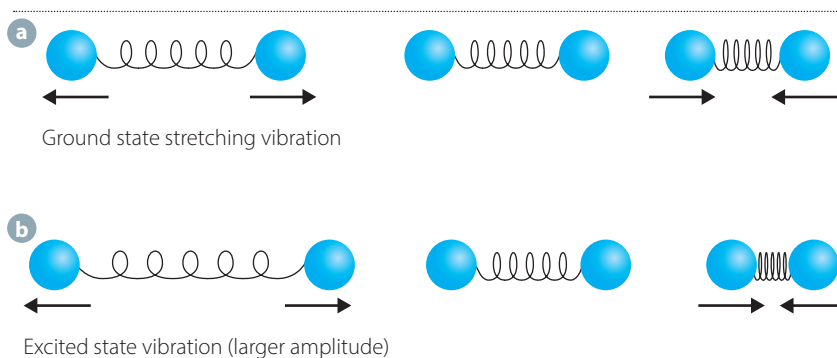
## 15.5 Infrared spectroscopy

Infrared spectroscopy is a useful technique for determining the bonds or functional groups that are present or absent in a compound. It is a relatively cheap and easy technique. It can be used in industrial applications for monitoring chemical pathways, in forensic examinations and in drug development.

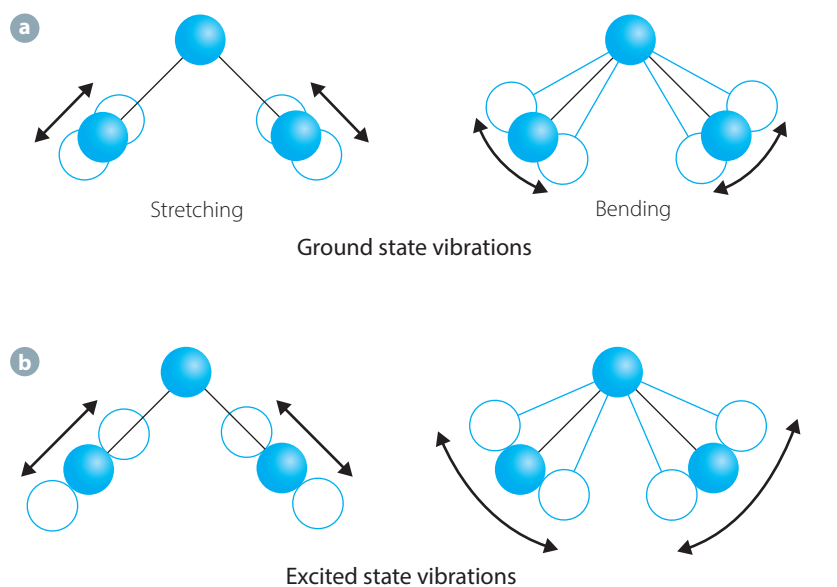
### Principles of infrared spectroscopy

Molecules are constantly moving. The two basic modes of vibration are stretching and bending. A simple diatomic molecule is like two heavy spheres connected by a spring; the spheres can vibrate backwards and forwards around their equilibrium position, as shown in Figure 15.24a. In polyatomic molecules, such as water, the general vibration modes are shown in Figure 15.25a (page 470).

The vibrations may be symmetrical or asymmetrical. A molecule can absorb infrared energy and change to higher energy vibration mode. The molecules will now vibrate with more energy and amplitude. Therefore, the spring will be stretched to greater lengths and compressed more, as shown in Figures 15.24b and 15.25b. When bending vibrations are excited, the change in angle is greater, as shown in Figure 15.25b. This is not true for diatomic molecules such as  $O_2$  and  $N_2$ . Hence, these molecules cannot be detected by infrared spectroscopy.



**FIGURE 15.24** Vibrations for **a** ground state and **b** excited state of a diatomic molecule



**FIGURE 15.25** **a** Ground and **b** excited states of two of the vibrations that triatomic molecules undergo

The energy absorbed by the atoms depends upon the bond length, the bond strength, and the atom's size. Heavier atoms require more energy to increase vibration. Double bonds require more energy than single bonds to increase vibration. Therefore, measurement of the absorbance will determine which bonds are present. Typical absorbance values are shown in Table 15.9 (p. 472).

During infrared spectroscopy, a sample is placed in a cell that is in a beam of infrared radiation. A number of different frequencies are absorbed by the compound. The percentage transmitted is recorded against the energy of the frequency. On the infrared spectra the  $x$  axis is the **wavenumber** ( $\text{cm}^{-1}$ ), which is the inverse of wavelength (cm). The  $x$  axis of the infrared spectrum always shows a dramatic change.

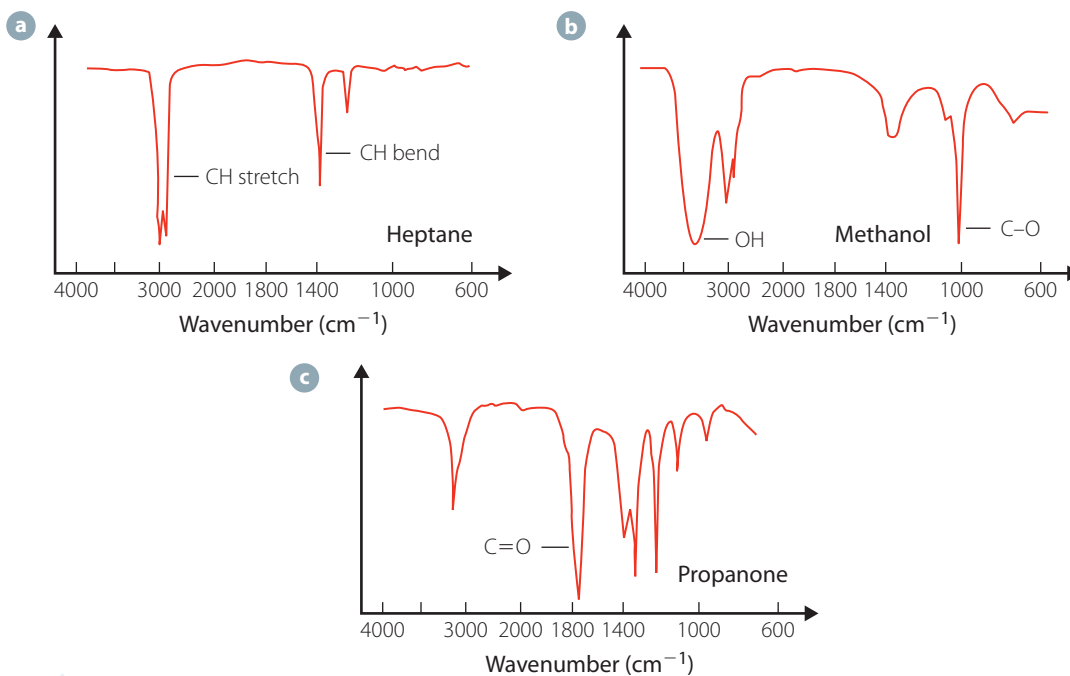
Unlike the earlier spectra, infrared spectra consist of a series of **troughs** from a baseline: the spectra looks 'upside down'. The  $y$  axis is the percentage of light transmitted. The baseline shows 100 per cent of the light still being transmitted. When the wavelength is absorbed, less of it will be transmitted, producing a lower percentage.

## Interpreting infrared spectra

To interpret infrared spectra, you look for key troughs or **absorption bands**. Infrared spectra consist of a large number of bands that are ignored when interpreting spectra because they are due to many different vibrational modes of the molecules that do not provide useful information. The key area to examine is in the higher wavenumber region. Notice in the spectra that the  $x$  axis has a change of scale. The troughs to the right of around  $1500\text{ cm}^{-1}$  are called the fingerprint region.

### Spectra fingerprint region

The region from  $1500\text{ cm}^{-1}$ – $500\text{ cm}^{-1}$  is called the **fingerprint region** and is 'unique' to a compound. It can be used to confirm the identity of the unknown compound by comparing its spectra to that of a known sample, as shown in Figure 15.26. It can also indicate whether the sample is pure if the fingerprint region of the sample matches that of a pure standard. However, the trough may be of different intensities due to the concentration differences between the two samples.



**FIGURE 15.26** Infrared spectra of heptane, methanol and propanone ( $\text{CH}_3\text{COCH}_3$ ). The broad trough at around  $3200\text{ cm}^{-1}$  is characteristic of an alcohol  $\text{—OH}$  stretch. The vibrations that cause the major absorption bands are identified.

Almost every organic molecule has a  $\text{—C—H}$  bond (where a hydrogen is attached to a carbon), which absorbs somewhere in the range from  $2800\text{—}3000\text{ cm}^{-1}$ . Therefore, this trough does not provide much information. Similarly, neither does the band due to a  $\text{—C—C}$  bond.

The  $\text{—OH}$  bond, as found in alcohols, typically absorbs at  $3000\text{—}3500\text{ cm}^{-1}$ . This is usually broad and characteristic. The  $\text{—C=O}$  bond at  $1700\text{ cm}^{-1}$  is also very useful. The presence of a broad trough at  $3000\text{ cm}^{-1}$  could indicate that the compound is an alcohol. But when present with a band also at  $1700\text{ cm}^{-1}$ , the compound could be a carboxylic acid.

**TABLE 15.9** Characteristic infrared absorption frequencies of some common functional groups

CLASS OF COMPOUND AND BOND	BAND POSITIONS ( $\text{cm}^{-1}$ )
ALKANES, ALKYL GROUPS	
C—H	2850–3300
C—C	750–1100
ALKENES	
—CH	3020–3100
—C=C	1620–1680
ALKYL HALIDES	
C—Cl	600–800
C—Br	500–600
C—I	500
ALCOHOLS	
—OH	3230–3500 (strong, broad)
—C—O	1050–1150
AMINES	
N—H	3310–3500
C—N	1030–1230
CARBONYL COMPOUNDS (SUCH AS CARBOXYLIC ACIDS AND ESTERS)	
C=O	1670–1780
CARBOXYLIC ACIDS	
—OH	2500–3100 (strong, broad)



Infrared spectra and vibrational modes of molecules

## INVESTIGATION 15.2

### Matching structures

#### AIM

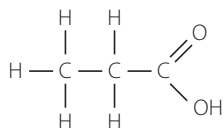
To identify structures from infrared and mass spectra data provided.

#### METHOD

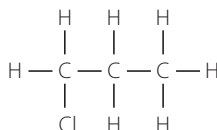
- 1 Examine the six molecules A–F and spectra 1–6.
- 2 Match the spectra to the organic molecules. (**Hint:** Calculate the molar mass.)
- 3 Look for possible common fragments.
- 4 Look for key functional groups in the infrared spectra.



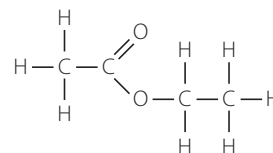
» Molecule A



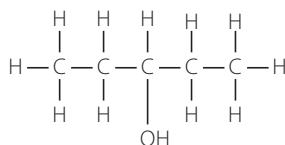
Molecule B



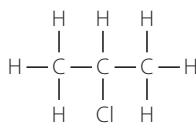
Molecule C



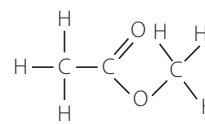
Molecule D



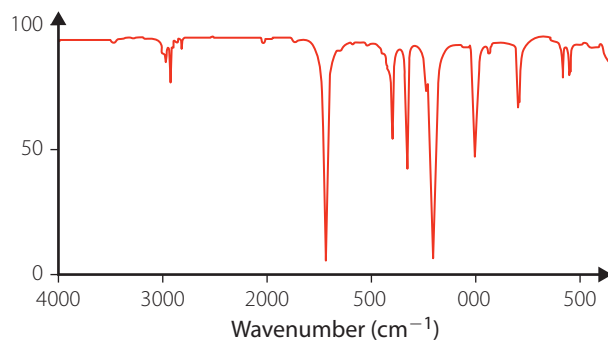
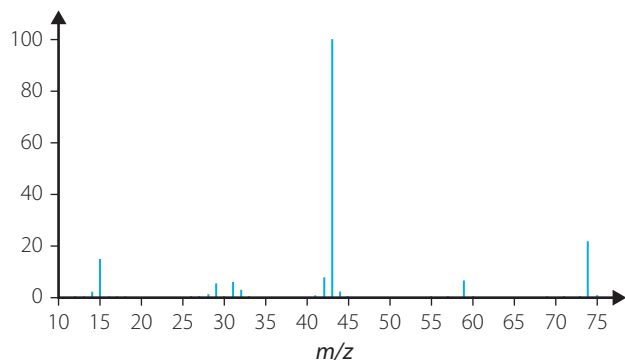
Molecule E



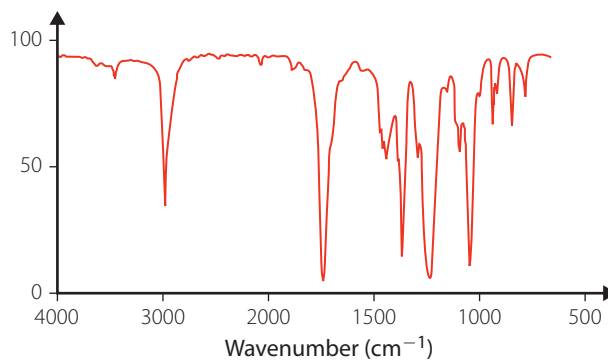
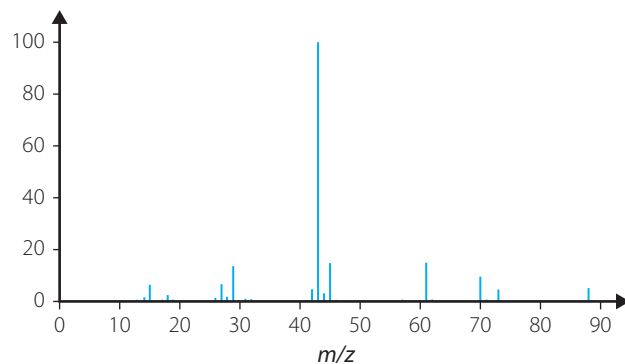
Molecule F



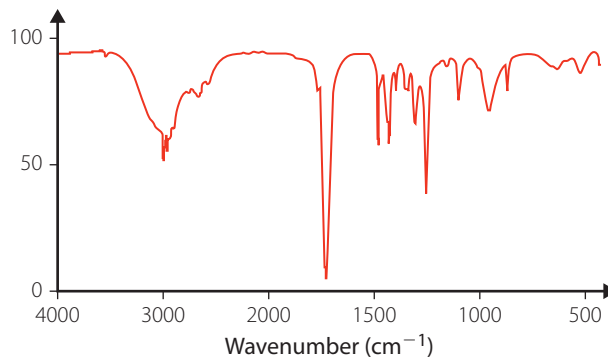
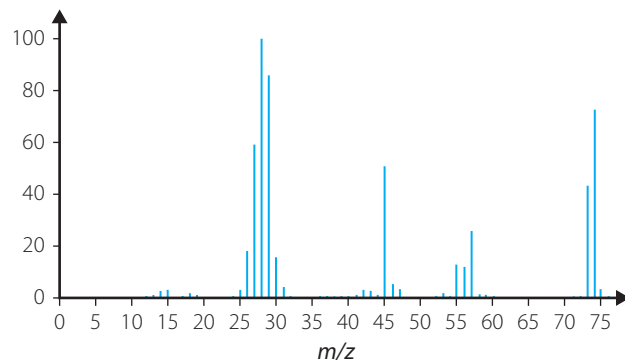
Spectra 1



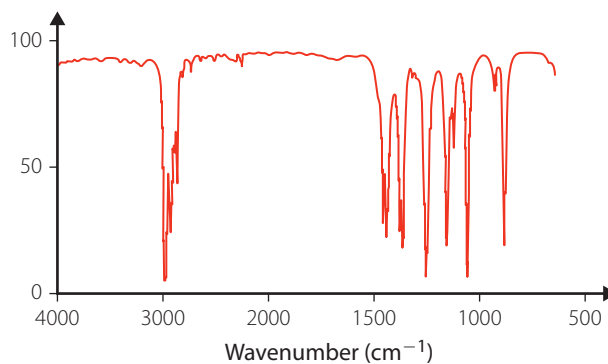
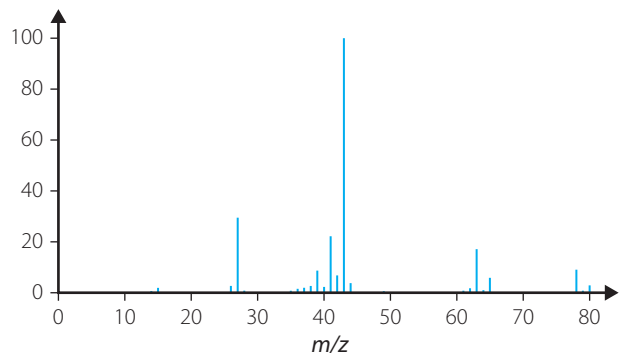
Spectra 2



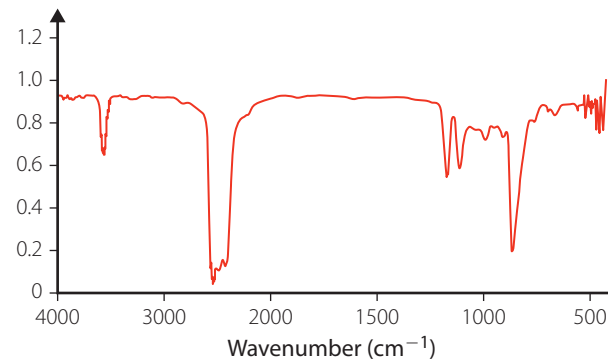
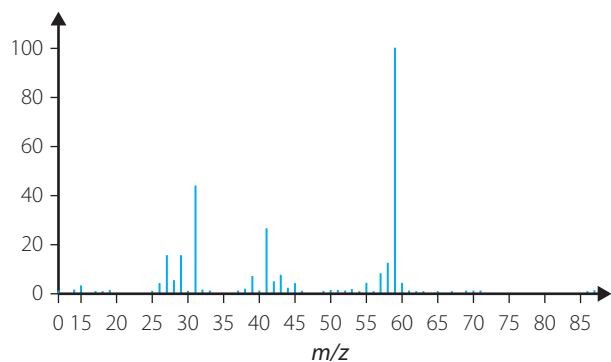
Spectra 3



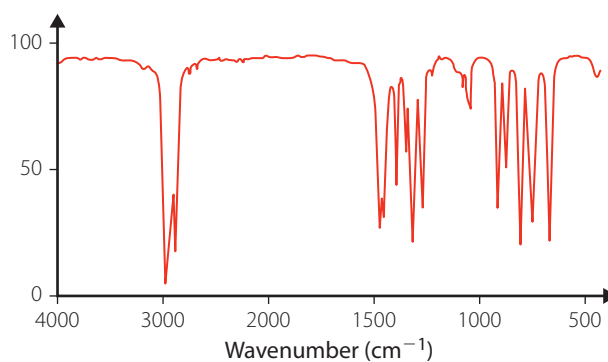
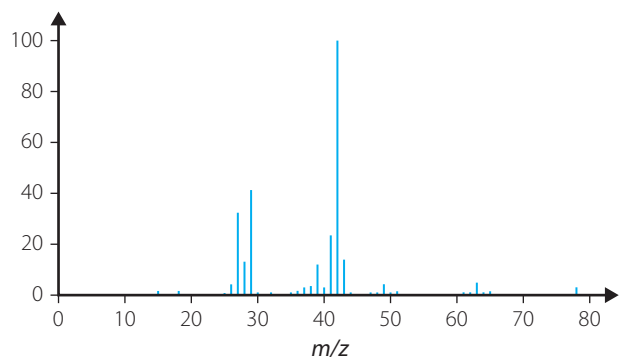
#### Spectra 4



#### Spectra 5



#### Spectra 6



#### DISCUSSION

- 1 Which spectra belong to which compound?
- 2 Give the correct IUPAC name for each compound.

- IR spectroscopy determines the presence or absence of functional groups. IR energy increases the vibration and bending of the molecule. The wavenumber of absorbed energy is affected by the size of the atoms, bond length and bond strength.

## 15.6

## Ultraviolet–visible spectrophotometry

UV–visible spectrophotometry is useful for determining the concentration of inorganic and organic molecules as well as metal ions. Therefore, it is useful in determining rates of reactions and equilibrium constants. UV–vis spectrophotometry is also widely used in the pharmaceutical industry as well as the dye, paint and ink industries in product quality control. The technique is similar to both atomic absorption spectroscopy (AAS) and colourimetry discussed in chapter 14.

## Principles of ultraviolet–visible spectrophotometry

UV–visible spectrophotometry uses the UV–visible part of the spectrum. The UV region ranges from 190–400 nm and the visible region from 400–800 nm. As with AAS and colourimetry, UV–visible spectrophotometry relies on the electrons in the molecules being excited to a higher energy state. When sample molecules are exposed to the wavelength of light energy that corresponds to an electron transition between energy levels, the light energy will be absorbed.

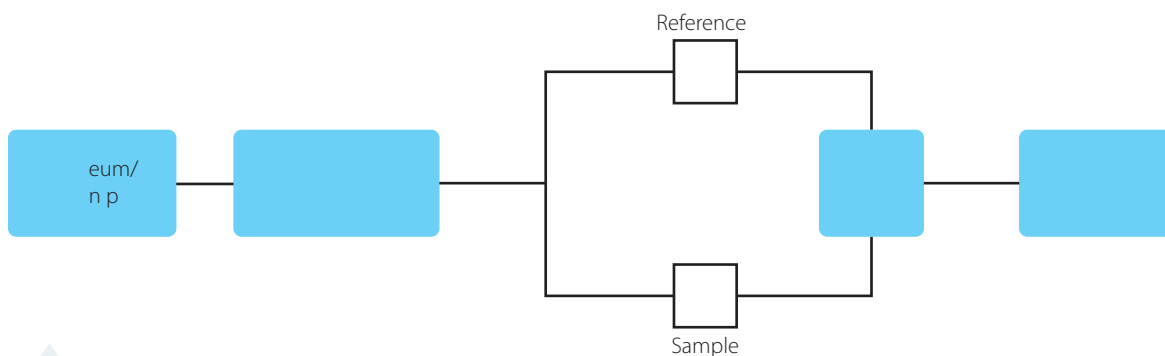
Most organic molecules are colourless so they do not absorb in the visible region of the spectrum. However, many natural and synthetic dyes and pigments have energy transitions that do absorb in the visible region. Metal ions often produce coloured compounds, so tend to absorb in the visible region of the spectrum also. The group of atoms responsible for UV–vis absorption are called **chromophores**.

In the spectrophotometer, the light source (a combination of tungsten/halogen and deuterium lamps) provides light of wavelengths between 200–800 nm. The light is focused onto a diffraction grating that splits it into different wavelengths. The different wavelengths of light are shone through two cells simultaneously. One cell contains the sample to be analysed and the other, the reference cell, contains only the pure solvent used in preparing the sample. An optical spectrophotometer records the wavelengths at which the absorption occurs and also the amount of absorption at each wavelength. Figure 15.27 shows a simplified diagram of a UV–vis spectrophotometer.

To calculate absorbance ( $A$ ) at a particular wavelength, the computer in the spectrophotometer divides the intensity of light at that wavelength before it passes through the sample ( $I_0$ ) by the intensity at that wavelength after it passes through the sample ( $I$ ) then takes the log to base ten of the ratio:

$$A = \log_{10}(I_0/I)$$

This value becomes the absorbance value used in the graph for that particular wavelength. The spectrum produced graphs absorbance against wavelength.



**FIGURE 15.27** Simplified diagram of a UV–vis spectrophotometer

The absorbance is related to the concentration of the solution. The greater the concentration, the greater the absorbance since there are more molecules or ions to absorb the light. The Beer–Lambert Law states the quantitative relationship between absorbance and concentration, as per equation at the top of the next page.



$$A = \epsilon lc$$

where:

- $A$  is absorbance – it does not have units since it is a  $\log_{10}$  of the ratio between the light entering and light exiting the solution.
- $\epsilon$  (or  $e$ ) is the molar absorptivity. It is a constant for a particular chemical. It is a measure of the amount of light that a solution containing that chemical absorbs per unit of concentration. The units for molar absorptivity are  $\text{L mol}^{-1} \text{cm}^{-1}$ .
- $l$  (or  $b$ ) is the path length of the light through the sample. The path length is measured in cm. In most cases, sample holders have a path length of 1 cm.
- $c$  is the concentration of the solution. The units for concentration are  $\text{mol L}^{-1}$ .

Since  $\epsilon$  and  $l$  are constants for an investigation, the Beer–Lambert Law indicates that there is a direct relationship between absorbance and concentration:

$$A \propto c$$

### Quantitative analysis

UV–visible spectrophotometry can be used to:

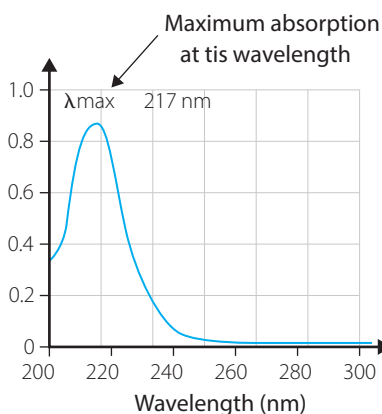
- confirm the identity of the substance by comparing the spectrum of a sample to the spectrum of a pure sample or standard of the compound
- calculate concentrations of a substance using a calibration curve of known concentrations of analyte.

### Identifying a substance

The wavelength (symbol  $\lambda$ ) at which the greatest amount of absorbance occurs is called  $\lambda_{\text{max}}$ .

Figure 15.28 shows the UV–visible absorption spectrum for 1,3-butadiene ( $\text{H}_2\text{C}=\text{CH}-\text{CH}=\text{CH}_2$ ) identifying  $\lambda_{\text{max}}$ .

If a sample was thought to be 1,3-butadiene, its UV–vis spectrum could be compared to Figure 15.28. If the spectra match, then the identity of the sample is confirmed. Table 15.10 lists some chromophores with examples and their absorbance wavelength.



**FIGURE 15.28** UV–vis spectrum for 1,3-butadiene

**TABLE 15.10** Chromophores with examples and maximum absorbance wavelengths

CHROMOPHORE (AND AN EXAMPLE WITH CORRESPONDING ABSORBANCE)	WAVELENGTH ( $\lambda$ ) MAX (nm)
C—H e.g. $\text{CH}_4$	170 173
C—X, e.g. $\text{CH}_3\text{OH}$ $\text{CH}_3\text{NH}_2$ $\text{CH}_3\text{I}$ $\text{CCl}$ $\text{CBr}$	180–260 187 215 258 173 208
C=C e.g. $\text{H}_2\text{C}=\text{CH}_2$	160–190 162
$\text{H}_2\text{C}=\text{CH}-\text{CH}=\text{CH}_2$	217
C=O e.g. $\text{H}-\text{CH}=\text{O}$	270, 170–200 270, 185
$\text{H}_2\text{C}=\text{CH}-\text{CH}=\text{O}$	328, 208
C=N	190, 300
N=O	630–700

Source: [https://web.vscht.cz/~poustkaj/EN%20ASFA%20AU%20Kopl%c3%adk%20UV\\_VIS\\_spectrometry.pdf](https://web.vscht.cz/~poustkaj/EN%20ASFA%20AU%20Kopl%c3%adk%20UV_VIS_spectrometry.pdf)

## INVESTIGATION 15.3

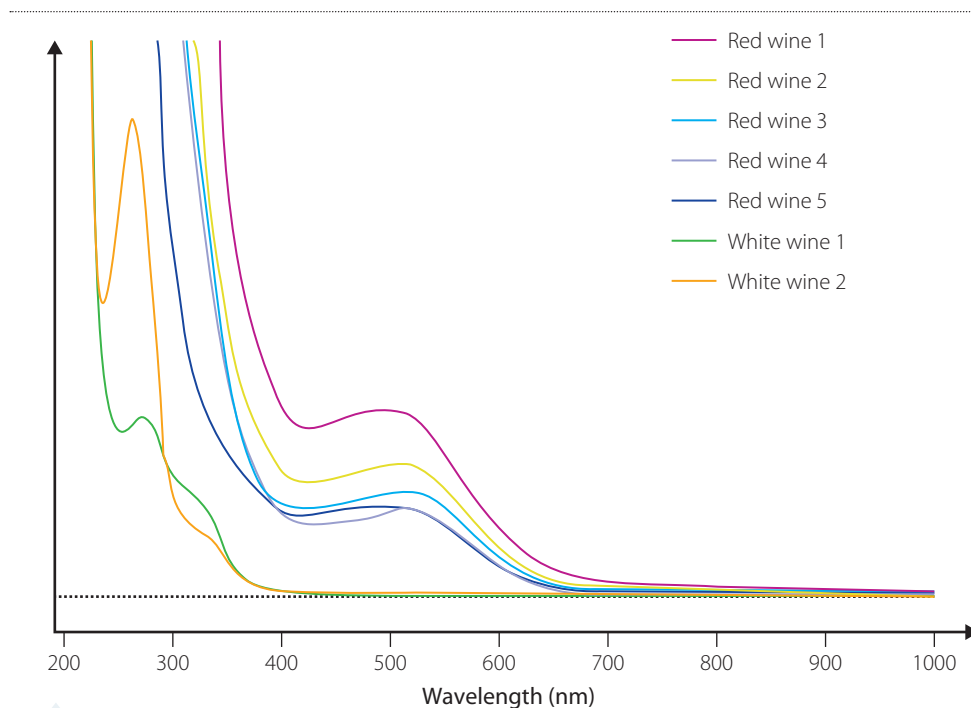
### Judging wine

#### AIM

To determine the wavelength for detecting phenolic compounds and to determine which ones are more common in red wine than in white wine.

**TABLE 15.11** Typical absorbance wavelengths for phenolic compounds

PHENOLIC COMPOUND	TYPICAL WAVELENGTH (nm)
Anthocyanins	267–275, 475–54
Benzoic acids	235–305
Hydroxycinnamic acids	Absorbance maxima at 227–245 and 310–332
Flavonols	Typically have maxima at 250–270 and 350–390



**FIGURE 15.29** Absorbance spectra of wine samples

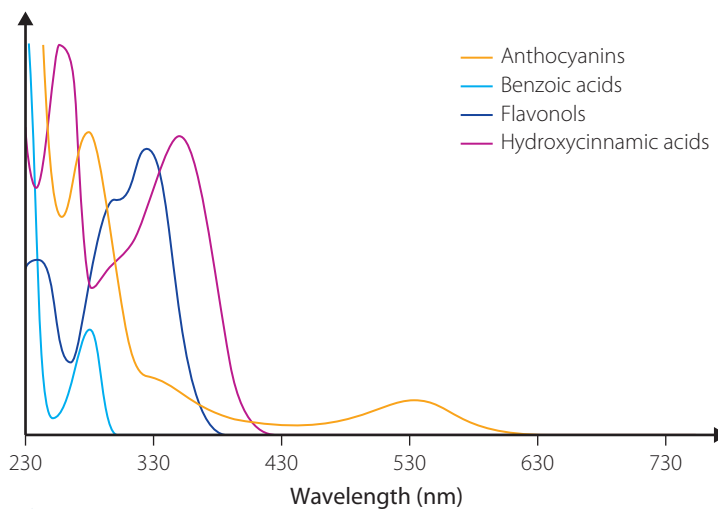


## » METHOD

As a winemaker, you need to judge the quality of the wine and be able to distinguish the different varieties. Phenolic compounds influence the colour and taste of the wine. It may be the grapes that cause the taste difference or it may be the treatment that allows the development of these different compounds.

The winemaker ran UV-visible spectra of different wines, as shown in Figure 15.29, and ran standard samples of the main phenolic compounds, as shown in Figure 15.30.

Use these spectra and Table 15.11 to determine which phenolic compounds are common in red and white wine.



**FIGURE 15.30** Absorbance spectra of main phenolic compounds found in wine

## DISCUSSION

- 1 Which specific wavelengths would you use to determine the different phenolic compounds? Justify your decisions.
- 2 Are there differences in the phenolic compounds in red or white wine?
- 3 Can these differences be determined by this technique using the provided data?

## Determining concentrations

As with colourimetry and atomic absorption spectroscopy, the unknown concentration of a sample can be determined from a calibration curve constructed from samples of known absorbance and concentration.

When determining the absorbance of known concentrations of the species being investigated, the UV-vis spectrophotometer is often set to the wavelength that gives greatest absorbance for that species (that is,  $\lambda_{\text{max}}$ ).



UV-visible  
spectrophotometry

### WORKED EXAMPLE 15.4

A chemical factory was accused of releasing untreated waste nitrate product into the local waterway. Ten samples of water were collected downstream and their absorbance was measured using UV-visible spectrophotometry. The average absorbance was found to be 0.426.

A series of seven standards of different nitrate concentrations were prepared and their absorbance at 220 nm was measured. The table below gives the absorbance of the standards.

$[\text{NO}_3^-]$ mg mL <sup>-1</sup>	0	0.015	0.025	0.035	0.045	0.05	0.06
ABSORBANCE	0	0.211	0.350	0.453	0.556	0.623	0.761

What is the nitrate content in the local waterway in mg mL<sup>-1</sup>?

ANSWER	LOGIC
<p>Calibration curve of absorbance vs <math>[\text{NO}_3^-]</math> mg mL<sup>-1</sup></p>	<ul style="list-style-type: none"> <li>Plot a calibration curve of absorbance vs <math>[\text{NO}_3^-]</math> mg mL<sup>-1</sup> for the standards.</li> </ul>
<p><math>[\text{NO}_3^-] = 0.0335 \text{ mg/mL}^{-1}</math> (Answer will depend on line of best fit drawn.)</p>	<ul style="list-style-type: none"> <li>Use the calibration curve to determine nitrate concentration for unknown sample absorbance.</li> </ul>

#### TRY THIS YOURSELF

Drug testing of urine involves identifying the products of particular drugs after they have been metabolised by the body. One particular banned drug produces an ester that is readily identified using UV-vis spectrophotometry. A series of standards of the ester were prepared and the following absorbance information was obtained from a UV-vis spectrophotometer at 400 nm.

CONC. ESTER (mol L <sup>-1</sup> )	0.1	0.2	0.25	0.35	0.5
ABSORBANCE	1.3	3.6	4.7	7.0	10.5

- The urine sample gave an absorbance of 6.5. Determine the concentration of ester in the urine.
- If the stoichiometric ratio of ester to drug molecule is 10:3, calculate the concentration of original drug ingested.

**Structure determination**  
Use the link to learn more about the types of instrumental analysis discussed and practice some different problems.

- UV-visible spectrophotometry is useful for determining the concentration of inorganic and organic molecules as well as metal ions.
- UV-visible spectrophotometry uses the UV-visible part of the spectrum.

## 15.7 Combining techniques



Check your understanding

Although a lot of information can be obtained by a single technique, much more information can be gained by combining them. Each technique provides one piece of the puzzle that is used to determine the whole structure. In 2002, the Nobel Prize in Chemistry was awarded for the development of a mass spectrometric analysis (John B. Fenn and Koichi Tanaka) and for the NMR development for biological macromolecules (Kurt Wüthrich). Their work determined the three-dimensional picture of what proteins look like in solution and enabled their function in the cell to be understood. Table 15.12 compares the advantages and disadvantages of typical techniques.

When you only have a small amount of sample, it is important to maximise the amount of information you can obtain from the techniques. The improved sensitivity of the instruments has meant that more information can be obtained. Precious artworks can be tested for authenticity by mass spectrometry and infrared spectroscopy – the pigments, glues and even the wooden frames can be analysed to determine if they originate from the era as well.

**TABLE 15.12** Typical analysis techniques for organic molecules

TECHNIQUE	MAIN FEATURE	WHAT IT DOES	ADVANTAGES	DISADVANTAGES
NMR spectroscopy	Radio waves excite odd nuclei in a magnetic field	Determines C—H backbone of organic molecules	Highly sensitive and precise Small sample size Sample can be in solution	Very expensive to buy and operate
Mass spectrometry	High-energy electrons produce cations, which are separated due to mass/charge	Determines molar mass, isotopic abundances	Very sensitive Small sample size	Very expensive to buy and operate
Infrared spectroscopy	IR radiation increases the energy of the vibrational modes of the organic molecule	Determines functional groups present	Huge range of analytes and samples Small sample size	Moderately expensive
UV-visible spectrophotometry	Electrons of the compound are excited due to the absorption of UV or visible light	Can detect if a species is present Can be quantitative	Useful for coloured organic and inorganic species Simple to operate Very cheap Small sample size Quick sample preparation	Not very sensitive

### CHECK YOUR UNDERSTANDING

15.5

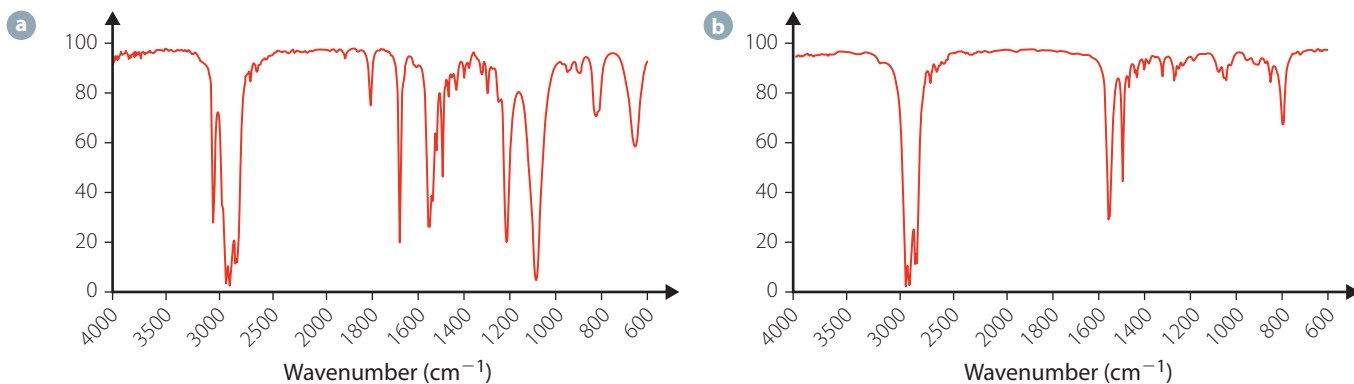
15.6

15.7

- 1 What technique would you use to determine the bonding groups in a compound?
- 2 What advantages are gained when techniques are combined?
- 3 What molecules cannot absorb infrared light?
- 4 Both UV-visible spectrophotometry and infrared spectroscopy use part of the electromagnetic spectrum.
  - a What is similar to both techniques and what are two differences?
  - b Which would be best for analysing a coloured compound? Why?
- 5 Group the following compounds into those that would show or not show a broad peak at  $3300\text{cm}^{-1}$  in an IR spectrum: 1-propanol, 2-propanol, ethane, ethanol, ethanoic acid, methanoic (formic) acid, ethyl ethanoate, butanoic acid, 1-chloroethane, 1-methylamine.



- 6 Two compounds, X and Y, react with sulfuric acid to produce a compound that smells like nail polish remover (methyl ethanoate). A student tried to make this compound.
- What would they see in the infrared spectrum to distinguish X and Y?
  - What would they see in the infrared spectrum for methyl ethanoate?
  - How would they be able to say that the sample is pure?
- 7 How could infrared spectroscopy be used to distinguish between the following pairs of compounds?
- Ethane and ethene
  - Ethanol and propanol
  - 2-chloropropane and iodomethane
  - 1-propanol and propanoic acid
- 8 The UV-vis spectra for a compound with molecular formula  $C_3H_4O$  showed absorbance peaks at 162 nm and 270 nm.
- Identify the chromophores present.
  - Draw a possible structural formula for the compound.
- 9 Compare the two spectra in Figure 15.31. Assign each to either 1-hexene or hexane. Justify your decision. Account for the main absorption bands.



**FIGURE 15.31** 1-hexene or hexane spectra (in no particular order)

## IMPORTANT NEW TERMS

After studying this chapter you should know the meaning of the following terms:

absorption band (p. 471)

alkoxide (p. 450)

atomic mass unit (amu) (p. 456)

base peak (p. 456)

chemical shift,  $\delta$  (delta) (p. 463)

chromophore (p. 475)

fingerprint region (p. 471)

isotope (p. 454)

$\lambda$  max. (p. 476)

molecular ion ( $M^+$ ) (p. 455)

neighbouring atom (p. 466)

nucleon (p. 461)

parent molecular ion (p. 456)

parent peak (p. 457)

radical (p. 455)

shielding (p. 462)

spin-spin coupling (p. 466)

splitting (p. 466)

tetramethylsilane (TMS) (p. 463)

trough (p. 471)

wavenumber (p. 470)

## AFTER STUDYING THIS CHAPTER YOU SHOULD KNOW:

- the definitions for all terms in the important new terms list
- chemical tests used to identify carbon-carbon double bonds, alcohols and carboxylic acids
- how mass spectrometry produces cations and which are used to determine molecular species
- how  $^1\text{H}$  and  $^{13}\text{C}$  NMR spectrometry is used to determine the different chemical environments within a molecule
- that IR spectroscopy will detect functional groups in organic molecules and that UV-vis spectrophotometry can detect some organic molecules.

## YOU SHOULD BE ABLE TO:

- use chemical tests to identify particular functional groups
- interpret mass spectra, including simple fragmentation patterns, and distinguish between organic compounds
- use tables to interpret NMR spectra, use this information to determine a molecule's carbon-hydrogen backbone, and hence, distinguish between different isomers
- interpret IR spectra by recognising key absorption bands, particularly the presence of  $-\text{OH}$  (alcohol),  $-\text{OH}$  (carboxylic acid) and  $-\text{C}=\text{O}$  bonds, and use this information to determine whether alcohols, esters or carboxylic acids are present, whether the substance is pure or whether a particular reaction has occurred
- use UV-vis spectra to identify organic and inorganic species and determine unknown concentrations from absorbance data
- recall the advantages and disadvantages of these techniques and determine when each one should be used and why some techniques are combined.



- What chemical tests would you use to distinguish between the following pairs of compounds?
  - 1-butanol and butanoic acid
  - 2-propanol and propane
  - Octane and 2-pentene
- Write equations for the following reactions and name the products.
  - 2-hexanol and sodium metal
  - Pentanoic acid and sodium carbonate
  - Bromine water and ethene
- Compare the use of instrumental analysis techniques with chemical testing, giving advantages and disadvantages of each.
- Which instrumental technique would be the easiest to use to distinguish carbohydrates, esters, carboxylic acids and amino acids?
- What information is given in a  $^1\text{H}$  and  $^{13}\text{C}$  NMR spectrum? Why is NMR spectroscopy such a valuable technique for determining the structure of proteins and larger molecules?
- Which technique is the best for determining the molar mass of a compound?
- Why is the molar mass for an element given on the periodic table not a whole number?
- What characteristic peaks would you expect in a mass spectrum of a chloroalkane?
- A chemist had three liquids: ethanol, butanoic acid and 3-heptene, but did not know which was which so called them P, Q and R. When drops of bromine solution were added to samples of each liquid, Q decolourised the bromine but P and R did not. When drops of sodium carbonate solution were added to fresh, dry samples of the three liquids, R produced bubbles of colourless gas but P and Q did not. When a piece of sodium metal was added to fresh samples of the three liquids P and R produced bubbles of gas but Q did not.  
Use the above information to identify each of P, Q and R, giving equations for the reactions that occurred.
- A compound was formed from the reaction of an alkene and HCl. The compound was 46% carbon and 9% hydrogen.
  - Determine the empirical formula for the compound.
  - Examine the mass spectrum (Figure 15.32) of the compound. What is the molecular formula for the compound?
  - Why is the parent peak not the peak with the largest  $m/z$  value in this case?
  - Draw the possible isomers for the compound.
  - Account for peaks at 43, 63 and 65.
  - Use the mass spectrum to decide which one is the most likely isomer.

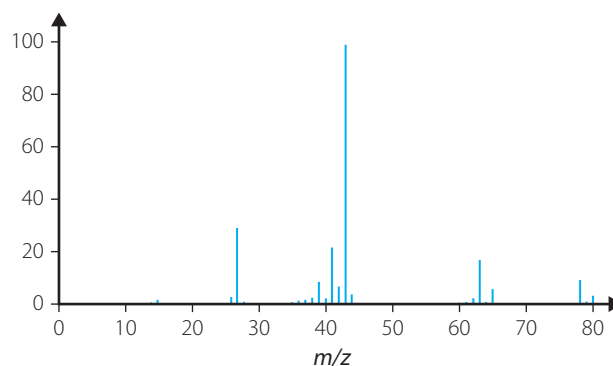


FIGURE 15.32 Mass spectrum of an unknown compound

- In court, criminals may claim that they were producing a perfume and not an illicit drug. How would infrared analysis help forensic scientists discredit the criminal? Would it be an advantage to take samples from the clandestine laboratory over time?
- NMR and mass spectra can be used to determine the structures of molecules. How do these techniques differ in this task? Is just one of these sufficient to determine the structure?
- How many peaks would be expected in a  $^1\text{H}$  NMR spectrum for propanone ( $\text{CH}_3\text{COCH}_3$ )?
- How could  $^{13}\text{C}$  NMR spectroscopy be used to distinguish between 1-nitropropane and 2-nitropropane?
  - Would the  $^1\text{H}$  NMR provide more information? If so what information would it provide?
- What differences would you expect in a mass spectrum of 1-propanol and 2-propanol?
- X is an organic compound composed of carbon, hydrogen and oxygen. It contains 48.63% carbon and 8.18% hydrogen by mass.
  - Calculate the empirical formula of X.
  - The mass spectrum for X is shown in Figure 15.33.

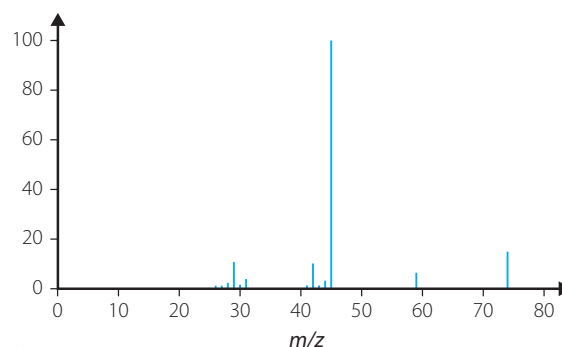


FIGURE 15.33 Mass spectrum of compound X

- i Deduce, giving a reason, the molecular formula of X.
  - ii Identify the formulae of the fragment ions with  $m/z$  values of 45 and 29.
- c The infrared spectrum of X is shown in Figure 15.34.

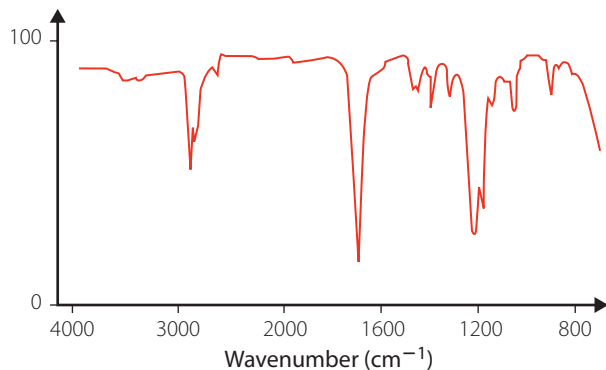
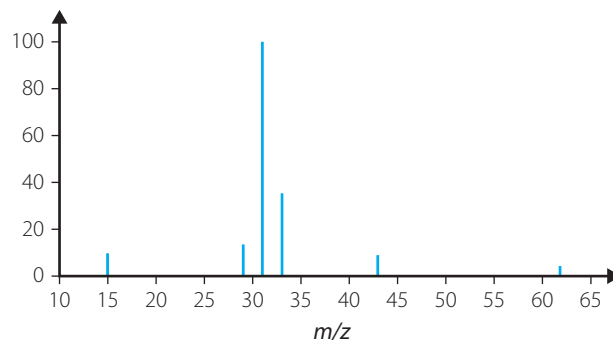


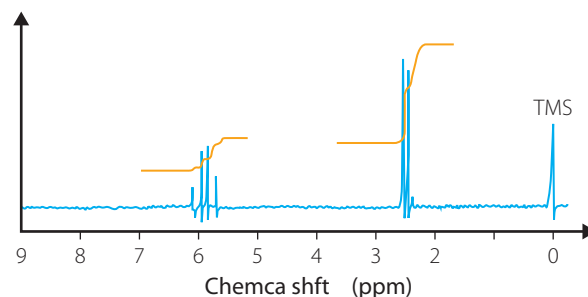
FIGURE 15.34 Infrared spectrum of compound X

- i Explain why X is not a carboxylic acid.
  - ii Identify, giving reasons, three bonds that are present in X.
- d Deduce the most likely structural formula of X based on your answers to parts b and c. State the name of X and give one use of compounds belonging to this homologous series.
- e State and explain the number of peaks compound X will show in its low-resolution  $^1\text{H}$  NMR spectrum.
- f State the names of two compounds that could react together to produce X. Identify the type of reaction and give an equation for the reaction.
- g Give structural formulae for two possible isomers of X.

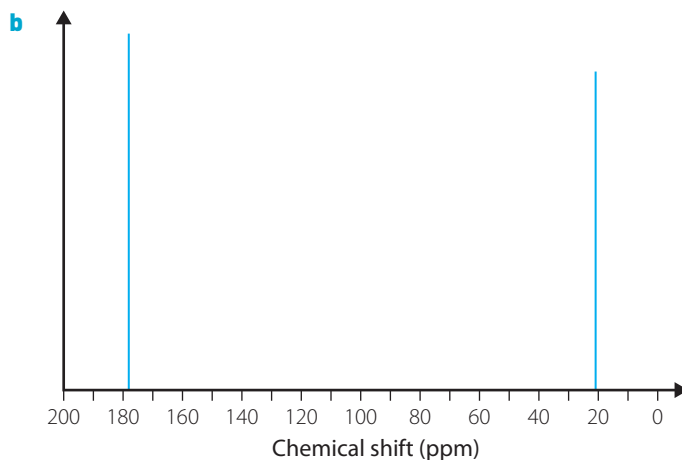
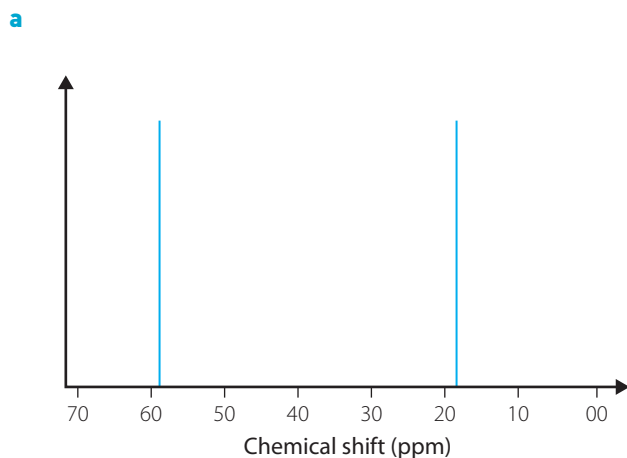
- 17 Assign the peaks for the mass spectrum in the figure below. Is the compound tested 1,2-ethanediol? How many peaks would you expect in the  $^1\text{H}$  NMR spectrum and the  $^{13}\text{C}$  NMR spectrum?

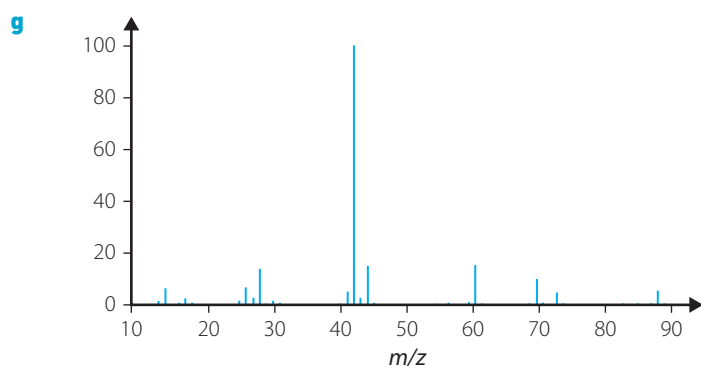
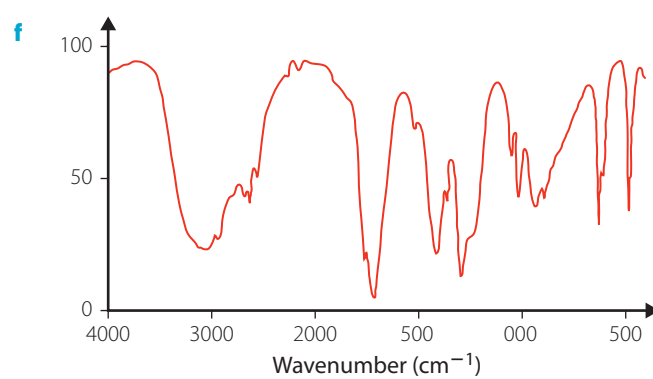
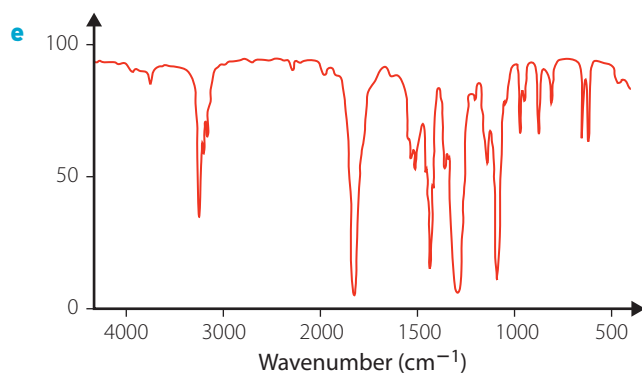
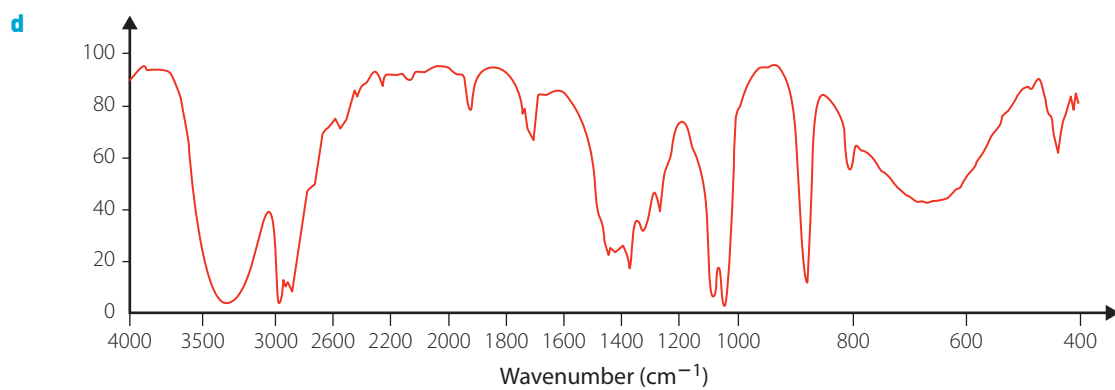
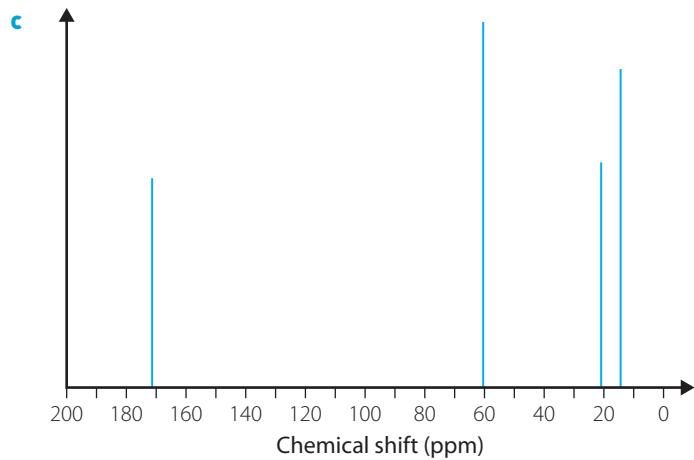


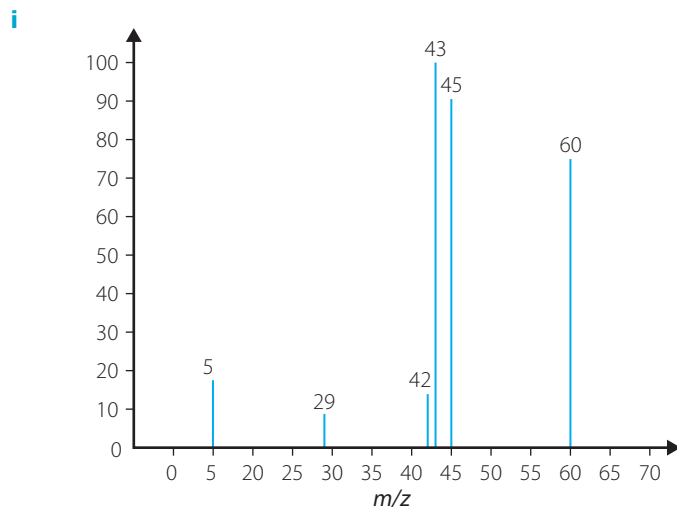
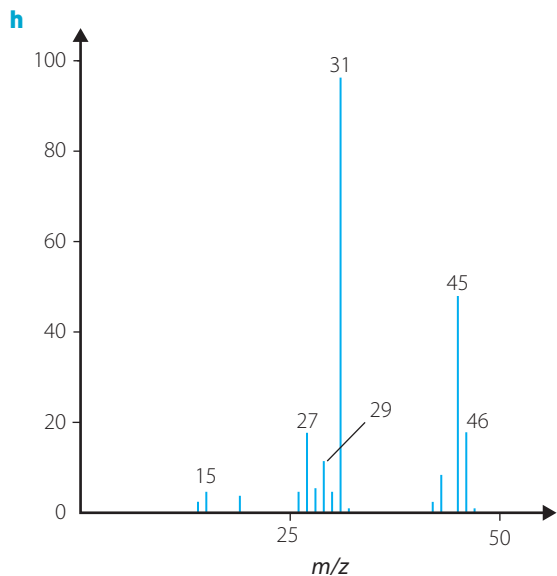
- 18 Salicylic acid and acetic (ethanoic) anhydride react to form aspirin. This reaction does not go to completion. The salicylic acid remaining will react with aqueous  $\text{FeCl}_3$  to form a purple compound  $\text{FeCl}_3$ . How can the purity of the product be quantified by UV-visible spectrophotometry?
- 19 The figure below is the  $^1\text{H}$  NMR spectrum of a compound with molecular formula  $\text{C}_2\text{H}_4\text{Br}_2$ . Use the information in the spectrum to determine the structure of the compound.



- 20 Compare the following  $^{13}\text{C}$  NMR, infrared and mass spectra. Assign each to ethanol, ethanoic acid or ethyl ethanoate. Justify your choices.

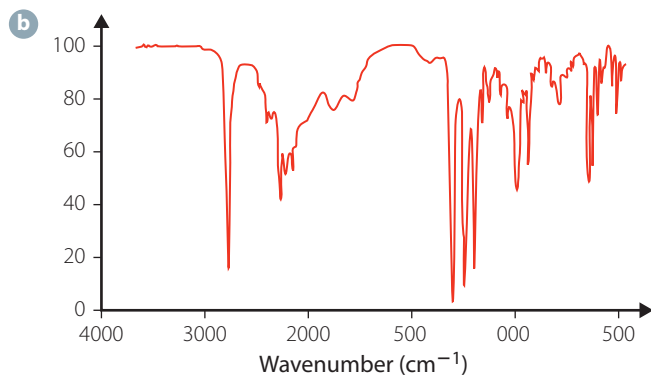
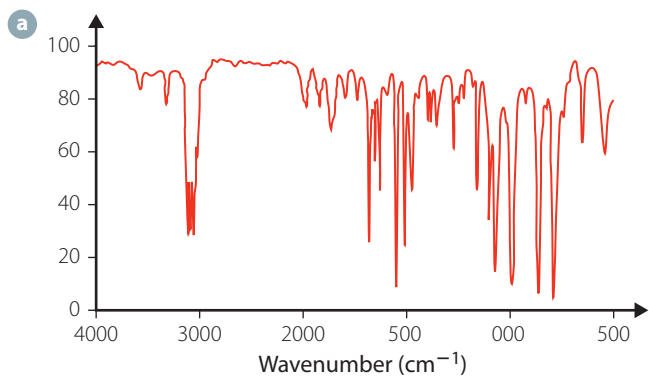






**21** A chemist had two different samples, A and B (left and right figures below, respectively). Elemental testing found both samples had the same chemical composition: 54.55% C, 9.99% H, 10.7% N and the remainder oxygen.

- Calculate the empirical formula for sample A and B.
- With the same empirical formula, the chemist tried chemical reactions to tell them apart. Samples A and B both reacted with acids and bases. What is the likely chemical group that sample A and B belong to?
- The chemist started to think that A and B were the same sample. So he ran infrared spectra on both and obtained the spectra seen in the figures below. Explain why the IR spectra confirm that they are *not* the same sample?



# 16 Chemical synthesis and design

## INQUIRY QUESTION

What are the implications for society of chemical synthesis and design?

### Students:

evaluate the factors that need to be considered when designing a chemical synthesis process, including but not limited to:

- availability of reagents
- reaction conditions ACSCH133
- yield and purity ACSCH134
- industrial uses (e.g. pharmaceutical, cosmetics, cleaning products, fuels) ACSCH131
- environmental, social and economic issues.

Chemistry Stage 6 Syllabus © NSW Educational Standards Authority for and on behalf of the Crown in right of the State of New South Wales, 2017





Prior knowledge



**FIGURE 16.1** Chemists can synthesise plastics that have specific properties.

When most people hear the word ‘chemical’, they tend to think of harsh, dangerous chemicals such as acids and bases. In reality, everything you come into contact with is a chemical. Every day you use a wide variety of substances produced by the chemical industry, many of which are made from plastics. More specifically, they are made by chemistry being applied to make a new product. In other words, they are **synthesised**.

Plastics are not the only things that are synthesised. Many of the items that we rely on are manufactured by synthesis reactions. Pharmaceuticals, fuels, cosmetics and cleaning products are just a few examples.

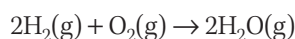
## 16.1 Synthesis reactions

Chemical synthesis is very important. Aspirin, artificial sweetener aspartame, sunscreen, paint and plastic are just a few of the chemicals that we use every day. Figure 16.2 shows three of these.

So far you have learnt about the synthesis of the biofuels – bioethanol, biodiesel (chapter 11); cleaning products – soaps and detergents (chapter 12), esters (chapter 12), ammonia (chapter 12), methanol (chapter 12) and polymers (chapter 13).

There are many factors to consider in the synthesis of a substance to ensure that the desired product is made in a cost-efficient, safe manner.

In chemistry, synthesis is used to describe two different chemical reactions. You learnt about the first one in *Chemistry in Focus Year 11* chapter 10, which is: synthesis reactions are reactions in which two or more reactants combine to form a single product. For example, in the pop test, hydrogen and oxygen gas combine to form water:



The second reaction involves carrying out chemical reactions to purposely produce a specific product. It is this form of chemical synthesis that you will consider in more detail in this chapter.

### Uses of synthesis reactions

With each of the huge variety of substances produced by chemical synthesis, a similar process is followed. Firstly, a desired product is identified, then the reactants required to make this product are identified and the **reaction pathway** is developed. In each case, the aim is to form the product as economically and safely as possible with the least wastage.

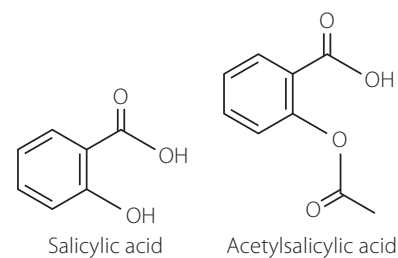
The pharmaceutical industry is responsible for the synthesis of thousands of different medicines each year. Aspirin (Figure 16.3) is a pharmaceutical drug that is commonly used worldwide to alleviate pain and fever. Its use dates back centuries when people would



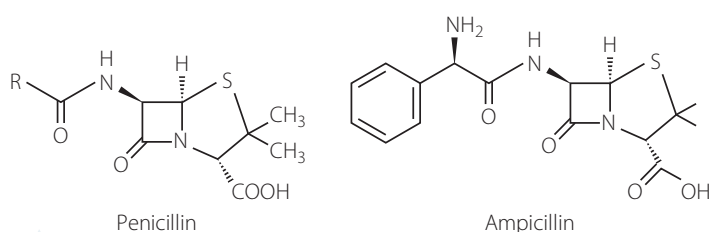
**FIGURE 16.2** Sunscreens are important chemicals that are synthesised to block UV radiation from the sun and help prevent sunburn and skin cancer.

eat ground-up willow bark to ease aches, pain and fever. The bark contains the compound salicin, which the body converts to salicylic acid. Unfortunately, salicylic acid can irritate the stomach. It was surmised that this side effect was due to the acidic nature of salicylic acid, so scientists looked for a way of modifying the molecule to reduce the acidity while maintaining the compound's activity. After much research and testing, it was found that changing salicylic acid to the ester, acetylsalicylic acid, achieved this effect. Aspirin is now manufactured on a huge scale utilising synthesis reactions.

Penicillin is another example of a pharmaceutical drug that is produced by synthesis reactions. Penicillin, discovered by Alexander Fleming in 1928, was collected originally from the *Penicillium* fungus. However, in 1948, John C. Sheehan started nine years of research into manufacturing synthetic penicillin. Although his method was not suitable for mass producing penicillin, one of the **intermediates** produced could be altered to form a variety of different forms of penicillin that are still used today, including ampicillin (Figure 16.4).



**FIGURE 16.3** Salicylic acid and acetylsalicylic acid are compounds that are effective in relieving pain.



**FIGURE 16.4** Structure of penicillin and ampicillin antibiotics, which are used to treat bacterial infections

- Chemical synthesis involves choosing suitable reactants to form the desired product.

- Define the following terms.
  - Synthesis
  - Reaction pathway
  - Intermediate
- List five substances that you commonly use that are produced through synthesis reactions.
- Write the equation for a simple synthesis reaction.
  - Explain how the type of synthesis reaction in part **a** is different from one used to produce a product such as aspirin.
- What are the next two steps chemists follow once they have identified a desired product to synthesise?
    - Suggest why these are the next two logical steps.
- Name possible reactants and briefly describe a method that could be used to synthesise the following products.
  - Ethylethanoate
  - Bioethanol
  - Soap

**CHECK YOUR UNDERSTANDING**

16.1



## 16.2 Designing synthesis reactions

Scientists have known about synthesis reactions since 1828 when Friederich Wöhler tried to produce ammonium cyanate from silver cyanate. The reaction did not produce ammonium cyanate, but instead one of its isomers, urea. Twenty years later, scientists produced another organic compound, acetic acid, from inorganic reactants. This was followed by the synthesis of a greater range of organic compounds. Since then, the range of compounds able to be synthesised has grown, as has the range of techniques that are utilised

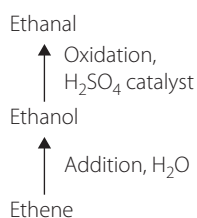
### Choosing the reactants

A common method of designing synthesis reactions is to start with the desired product and work backwards. This process is called **retrosynthetic analysis** and was developed by Professor E. J. Corey. Retrosynthetic analysis has changed the way organic compounds are synthesised and Corey was awarded the Nobel Prize in Chemistry in 1990.

Many chemicals synthesised are organic compounds. In the synthesis of these compounds, the steps are identified by starting with the product and then gradually removing carbons or simplifying the compound until suitable reactants are identified.

For example, ethanal is an aldehyde with two carbons in the chain. This aldehyde can be made from ethanol – a primary alcohol with two carbons in the chain. This alcohol can be made from ethene. Therefore, in this case, the initial reactant would be ethene, as shown in Figure 16.5.

Of course ethene is not the only starting point for the production of ethanol. As you learnt in chapter 11, ethanol is also produced by fermentation. In this case, the initial reactants would be an agricultural crop (corn, sorghum, wheat or sugar cane), yeast and water. The choice of the initial reactant/s would be determined by factors including availability, method by which the product is made, and the cost.



**FIGURE 16.5**  
Retrosynthetic analysis for the production of ethanal

### Choosing the reaction pathway

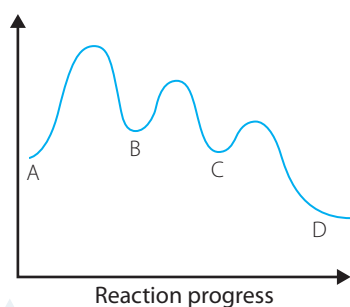
In most cases, the synthesis reaction involves more than one step. There are many factors to consider when deciding on the appropriate steps. These include other possible products, availability and cost of reactants and the conditions required for the reaction. Although there may be more than one possible pathway, or **reaction mechanism**, chemists choose the pathway that allows them to produce the product as cheaply, safely and efficiently as possible.

In a **multistep reaction**, each step will have its own reactants, products and activation energy. These will affect the speed of the reaction and the chemicals available for the next step. Along the pathway,

the products of one step may be used as reactants for another step. Therefore, these products are used up during the process. These chemicals are known as intermediates. An energy profile diagram can be used to represent the stages of the reaction, as shown in Figure 16.6.

In Figure 16.6:

- ▶ A is a reactant
- ▶ B and C are intermediates
- ▶ D is a product.



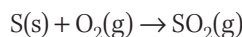
**FIGURE 16.6** Energy profile diagram for a multistep reaction

When choosing the most appropriate steps, scientists will also consider any side reactions that may occur and take steps to prevent these happening. This will maximise the **purty** of the product.

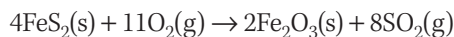
## Multistep process

The **contact process** is a method used to produce sulfuric acid. It involves a multistep reaction pathway. The steps have been chosen to allow the acid to be produced as efficiently and safely as possible.

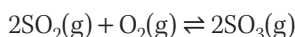
The first step involves the production of sulfur dioxide through the **combustion** of either sulfur or sulfide ores such as iron(IV) sulfide:



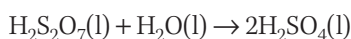
or



In the second step, the sulfur dioxide reacts with oxygen to produce sulfur trioxide:

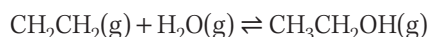


The sulfur trioxide is then dissolved in concentrated sulfuric acid before reacting it with water to produce sulfuric acid:

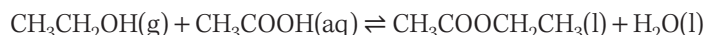


Each step in the reaction mechanism has its own reactants and products, the product in one reaction being the reactant in the next. Therefore, sulfur dioxide and sulfur trioxide can be considered as intermediates in the overall reaction.

Another example of a multistep pathway is the production of ethyl ethanoate, which is used in glues, nail polish removers, decaffeinating tea and coffee and as a solvent. In the first step, ethene reacts with steam to form ethanol:



In the second step, ethanol reacts with ethanoic acid to produce the ester ethyl ethanoate:

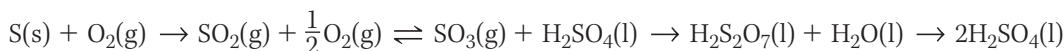


The steps and the conditions under which reactions are carried out are chosen for a specific reason. The reason for the specific conditions in each step will be considered using examples in the next section.

## Linear and convergent pathways

The sequence of steps in the reaction mechanism is another factor that scientists must consider when designing synthesis reactions. The sequence may be either linear or convergent. A **linear sequence** has one reaction following the other, with the products of one reaction being used in the next reaction, as seen in Figure 16.7.

The contact process described above is an example of a linear sequence. The sulfur dioxide produced in the first reaction is used in the second reaction. The sulfur trioxide produced in this second reaction is then used in the third reaction. Then, the oleum ( $\text{H}_2\text{S}_2\text{O}_7$ ) produced in the third reaction is used in the final reaction, which produces sulfuric acid.



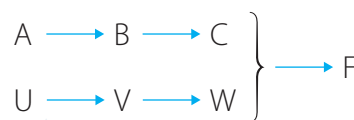
A **convergent sequence** uses different reaction pathways and then the products from these are combined as reactants in another reaction, as seen in Figure 16.8.

The synthesis of an ester is an example of a convergent process. An ester is produced by the reaction of a carboxylic acid with a primary alcohol in the presence of an acid as a catalyst. Therefore, the synthesis of an ester would involve:

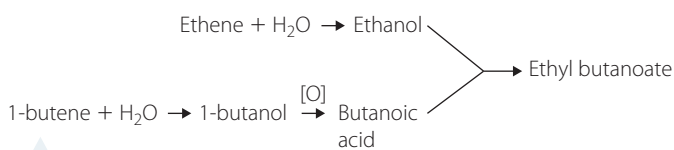
- 1 production of the appropriate carboxylic acid
- 2 production of the appropriate alcohol
- 3 reacting the carboxylic acid with the alcohol in the presence of an acid catalyst such as sulfuric acid.



**FIGURE 16.7** A linear synthesis sequence



**FIGURE 16.8** A convergent synthesis sequence



**FIGURE 16.9** The convergent synthesis of ethyl butanoate. [O] represents an oxidation reaction.

The convergent process for the synthesis of ethyl butanoate can be represented by the flow chart in Figure 16.9. Ethyl butanoate is an ester with a banana odour.

For each synthesis, the individual reactions should be considered to determine the best pathway. However, if the efficiencies of the reactions are similar, then a convergent sequence would have a higher overall yield than a linear synthesis of the desired product.



Designing a synthesis reaction

- Chemical synthesis is the use of chemical reactions to produce a specific product.
- Retrosynthetic analysis involves starting with the final product and using chemical knowledge to choose an appropriate reactant.
- Reaction pathways are designed to be as efficient and safe as possible.
- Reaction pathways can be convergent or linear.

## CHECK YOUR UNDERSTANDING

16.2

- 1 List some factors that must be considered when choosing the steps in a reaction pathway.
- 2 Explain the process of retrosynthetic analysis.
- 3 Explain why the contact process is considered a linear sequence.
- 4 In Check your understanding 16.1, question 5, you suggested possible reactants and a method for producing three different substances. For each of these explain:
  - a whether other reagents would need to be first produced and if so what they could be
  - b if the method you used was linear or convergent.
- 5 Explain why it is important to choose the most suitable reactants and reaction pathways when designing a synthesis reaction.

## 16.3 Yields of reactions

In chapter 2, you considered factors that affected equilibrium. These factors could affect the forward and reverse directions of the reaction, resulting in more or less product depending on the reaction being considered. When determining the conditions for the reactions of a synthesis process it is important to maximise the amount of product; that is, the **yield** of the reaction. This is very important in synthesis reactions because these factors will determine whether the process is economically viable.

### What is yield?

When you perform calculations in chemistry, you often assume that all the reactants will react to form the products. In reality, this does not always happen. The yield of a reaction refers to the amount of product actually produced from the reactants. A reaction with a high yield will produce a large amount of product from the reactants.

### Maximising yield

In industry, it is desirable to make as much of the product as possible. To facilitate this, the conditions would be managed so that **equilibrium** lies as far to the right as possible. This means that at equilibrium, there will be a much higher proportion of products than reactants. This means that a high proportion

of the reactants have become products. The conditions required will vary depending on the reaction; however, there are some common features.

- ▶ *The removal of the product:* by decreasing the concentration of a product, the forward reaction will be favoured, shifting equilibrium to the right.
- ▶ *Recycling of reactants that have not been used:* by recycling the unused reactants, there is less wastage. It also increases the concentration of a reactant. This favours the forward reaction, shifting equilibrium to the right.
- ▶ *Conducting the reaction at an appropriate temperature:* the temperature chosen should favour the forward reaction so that equilibrium lies as far to the right as possible. At the same time, the effect on the rate of the reaction and the cost of heating should be considered.
- ▶ *Choosing a suitable pressure for a system including gases:* the pressure of a gaseous system will affect the position of equilibrium; therefore, the pressure used should favour the forward reaction so that equilibrium lies as far to the right as possible. However, the effect on the rate of the reaction, cost and safety should also be considered.
- ▶ *Using a catalyst:* the addition of a catalyst is often used to increase the rate of production of the product. While this does not increase the yield, it will mean that the product is produced in a shorter time.

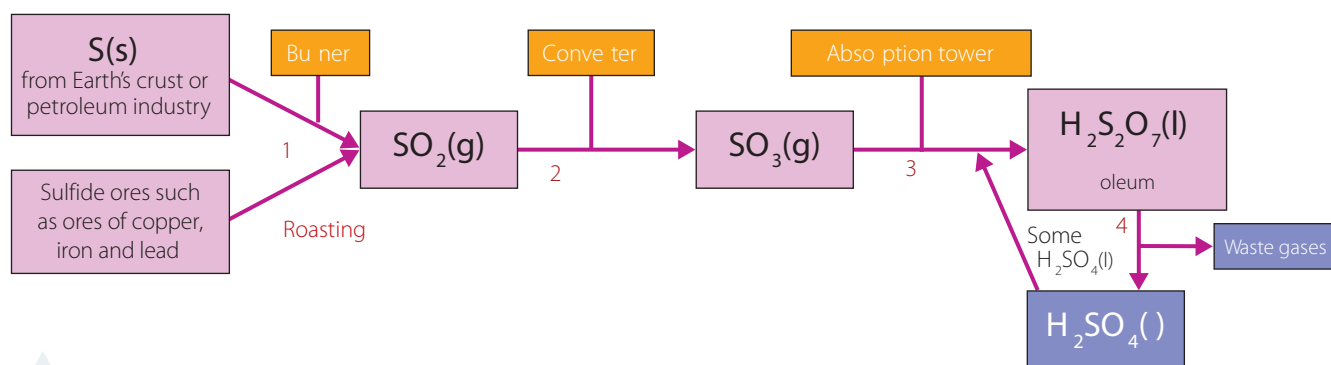
When designing the reaction conditions, the rate at which the yield is produced must also be considered. In an ideal situation, the reaction would have a high yield and this would be produced at a fast rate. That way, a large amount of product is produced in a short time, thus maximising profit and minimising wastage. However, a compromise must often be reached between the yield and rate of the reaction when the one condition has opposite effects on the yield and rate.

Purity of the required product is also important. This means any unwanted **by-products** must be removed before the final product is collected or removed from the final product following collection. There are varying grades of purity that may or may not be acceptable depending on the final use of the product. For example, bioethanol, which is produced as a fuel additive, may be acceptable at 95 per cent pure, while bioethanol, which is produced for further use in laboratories or in the production of pharmaceuticals, must be 99.9 per cent pure.

## The contact process – understanding the conditions used

One of the most important chemicals produced and used worldwide is sulfuric acid. Sulfuric acid is used in metal production, and in the production of paints, fertilisers, car batteries, detergents, dyes and fibres and in agriculture.

The process for making sulfuric acid is called the contact process. This allows high-concentration sulfuric acid to be produced in large quantities. In section 16.2, the reactions were considered. Here, the process and conditions will be examined. The process has a number of stages, as seen in the flow chart in Figure 16.10.



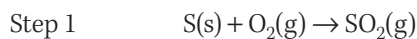
**FIGURE 16.10** Stages of sulfuric acid production



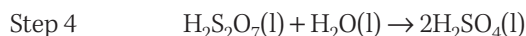
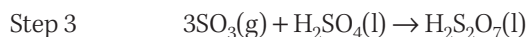
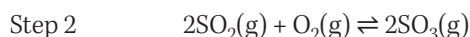
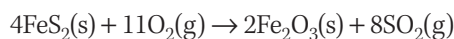
**Contact process**  
For more information  
about the contact  
process

## Excess reagent

In step 1, air is used as the source of oxygen. This is cheap and readily available. An excess of air is used, which provides the oxygen needed for step 2 as well. This makes the process more efficient since the two reactants for step 2 are already mixed together. However, the amount of air is controlled so that the ratio of sulfur dioxide to oxygen is 1:1.

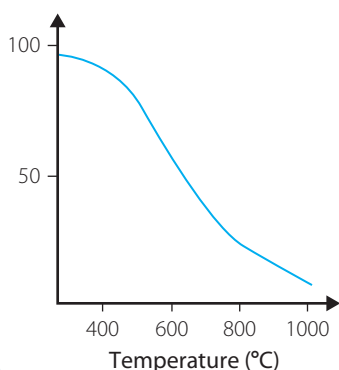


or



From the equation for step 2, you can see that the stoichiometric ratio of the two reactants is  $2\text{SO}_2:1\text{O}_2$ . Therefore, the 1:1 ratio provided gives an excess of oxygen gas. This has the combined effect of increasing the reaction rate and increasing the yield of sulfur trioxide.

The reaction rate is increased due to the increased concentration of the reactant, thereby increasing the number of collisions between reactant particles. By increasing the concentration of a reactant, the rate of the forward reaction will increase due to the increased number of collisions. This will shift equilibrium to the right and therefore increase the yield of sulfur trioxide.



**FIGURE 16.11** Yield of sulfur trioxide as temperature changes

## Temperature

The combustion of sulfur dioxide in step 2 is an **exothermic reaction** with a **heat of reaction** of  $-196\text{kJ mol}^{-1}$ . An increase in temperature would lead to an increase in the rate of reaction due to the increased percentage of particles with enough energy for a successful collision. However, an increase in temperature would favour the endothermic reaction, which in this case is the reverse reaction. This would lead to a decreased yield of sulfur trioxide. Therefore, a compromise temperature of  $400\text{--}450^\circ\text{C}$  is used, as indicated in the graph in Figure 16.11. This allows a relatively high yield of sulfur trioxide to be produced in a relatively short time.

## Pressure

The pressure of the chamber for step 2 is 1–2 atm. A higher pressure would increase both the rate of the reaction and the yield of sulfur trioxide. The rate of the reaction would increase due to the increased concentration of the reactants and therefore the number of collisions between the particles. Since there are more gaseous molecules in the reactants than the products, an increased pressure will increase the rate of the forward reaction more than the reverse. Therefore, equilibrium will shift to the right, increasing the yield of sulfur trioxide. However, it is very expensive to produce and maintain a high pressure safely; this cost outweighs the benefits gained. Therefore, a lower pressure is used.

## Catalyst

The aim of the process is to produce as much sulfuric acid as quickly as possible. For this reason, a catalyst of vanadium oxide ( $\text{V}_2\text{O}_5$ ) is used in the step 2. Although this does not affect the yield of sulfur trioxide, it will increase the rate at which it is produced, thereby increasing the rate that the next step is able to proceed at.

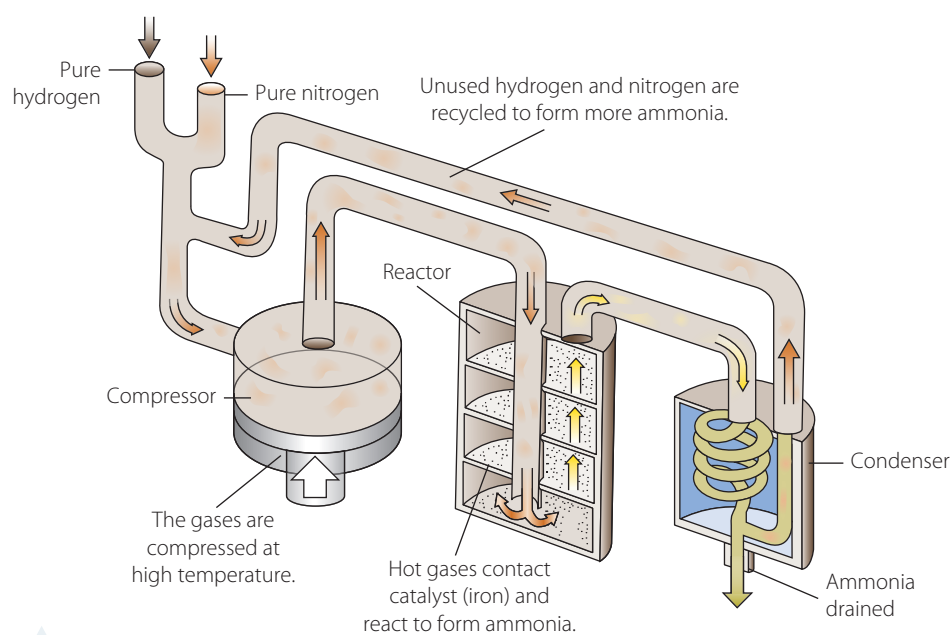
If you consider steps 3 and 4, it would seem counterproductive to add sulfuric acid when this is the desired product. If water was added directly to the sulfur trioxide, then sulfuric acid would be produced. However, this reaction is uncontrollable and will produce a fog of sulfuric acid. By dissolving the sulfur

trioxide in the sulfuric acid first, the reaction can be controlled and the sulfuric acid produced can be collected efficiently. When the molecules of sulfuric acid added and produced are considered, it is clear that all of the sulfuric acid added is retrieved in the products in addition to the new sulfuric acid produced.

## The Haber process – a compromise between yield and rate

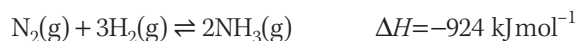
The **Haber process** is the main method for the production of nitrogen-based fertilisers. It was developed in 1915 and involves the addition of nitrogen and hydrogen to form ammonia. The ammonia produced is then used as a feedstock for the production of fertilisers. An industrial plant can produce around 1000 tonnes of ammonia per day. To produce chemicals at this level, chemists have worked to make the reactions as efficient as possible, while making as much profit as they can.

A diagram showing the equipment and method used in the Haber process can be seen in Figure 16.12.



**FIGURE 16.12** The industrial production of ammonia

The equation for the reaction is:



As with most industrial syntheses, the aim is to maximise the amount of ammonia produced in a given time at the lowest cost. Conditions are chosen that maximise the yield and rate, while being cost efficient. In chapter 12, Figure 12.19, the Haber process was represented using a flow chart and the conditions for the reaction were briefly discussed. Now let us consider them in more detail.

### Temperature

Increasing the temperature will increase the rate of the reaction because more particles will have sufficient energy for a successful collision.

Decreasing the temperature will increase the yield because decreasing the temperature favours the exothermic reaction. In the Haber process, the exothermic reaction is the forward reaction; therefore, decreasing the temperature will increase the yield of ammonia. However, decreasing the temperature will also decrease the rate of the reaction.



Raw materials



Extent of reaction and temperature



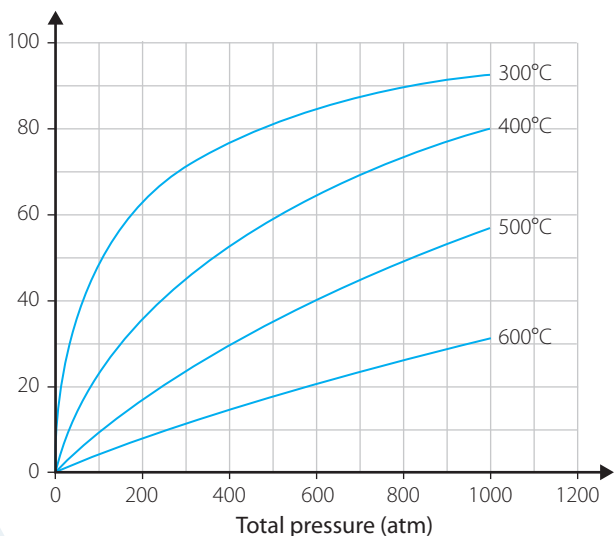


**Haber process**  
For more information  
about the Haber  
process

Therefore, a compromise is made between rate and yield. A temperature of 400–450°C ensures that enough ammonia is produced in an adequate time.

## Pressure

The rate of the reaction is increased by increasing the pressure of the system because this increases the concentration of the reactants and therefore the number of collisions.



**FIGURE 16.13** Production of ammonia at different temperatures and pressures

Yield is also increased by increasing the pressure as shown in Figure 16.13. Higher pressures favour the reaction that produces the least number of gaseous molecules. In the Haber process, this is the forward reaction and therefore the yield of ammonia is increased.

Although a higher pressure increases both the yield and rate, extreme pressures have associated risks and cost. It is expensive to produce and maintain a very high pressure. There is also the risk of explosions if the pressure is greater than the container can withstand.

A pressure of approximately 200 atm provides a balance between the high rate and yield, and cost and risks associated with even higher pressures.

## Catalysts

As previously mentioned, catalysts do not affect the yield of the reaction, but they can affect the rate. In the Haber process, an iron/iron oxide catalyst is used with a

small amount of potassium oxide and aluminium oxide. This provides an alternative pathway for the reaction with a lower activation energy. Therefore, more particles will have sufficient energy for a successful collision.

**Enzymes** are biological catalysts. They are proteins whose properties, including shape, allow them to interact with the reactants of a reaction so that it is easier for the reaction to occur.

This increases the rate of the reaction, in many cases making the reaction occur at a viable rate.

Enzymes are also used in industry to catalyse reactions. For some reactions, the temperature and pressure required for an adequate rate would be uneconomical. For others, the yield at high temperatures or pressures may be too low and so lower temperatures or pressures are used despite the lower reaction rate. The addition of a catalyst can allow the reaction to proceed at a higher rate despite the lower temperature and/or pressure.

Enzymes are also used in the production of biodiesel and ethanol.

## Calculating the theoretical yield – limiting reactants

The theoretical yield is the amount of product that can theoretically be produced from the reactants. It is based on the assumption that the reactants react with 100 per cent efficiency. In reality, many factors affect how much product is formed. One of these is the amounts of each reactant. As soon as one reactant runs out, the reaction can no longer proceed and no more product can be made. This reactant is known as the **limiting reactant** or **limiting reagent**. The other reactants are the **excess reactants** or **excess reagents**.

There are many different methods for determining which chemical is the limiting reactant. In each case, the number of moles of each reactant is compared to the stoichiometric ratios needed in the reaction. One method is demonstrated in Worked example 16.1.



The role of catalysts  
in the production of  
materials



Theoretical yield and  
percentage yield



Once the limiting reactant has been determined, it is used to calculate the number of moles, and then the mass, volume or concentration of the product.

### ▶ WORKED EXAMPLE (16.1)

The synthesis of paracetamol ( $C_8H_9NO_2$ ) is a three-step process with the final step being the reaction between *p*-aminophenol ( $C_6H_7NO$ ) and ethanoic anhydride ( $C_4H_9O_3$ ):



If 0.5 g of *p*-aminophenol reacts with 0.4 g of ethanoic anhydride, what mass of paracetamol can be produced?

ANSWER	LOGIC
$n = \frac{m}{M}$ $n(C_6H_7NO) = \frac{0.5}{109.1} = 0.00458 \text{ mol}$ $n(C_4H_9O_3) = \frac{0.4}{102.1} = 0.00392 \text{ mol}$	<ul style="list-style-type: none"> <li>Calculate the number of moles of each reactant.</li> </ul>
$SR = \frac{1}{1} = 1$ $AR = \frac{0.00458}{0.00392} = 1.168$	<ul style="list-style-type: none"> <li>Determine the stoichiometric ratio (SR), using the coefficients from the equation, and actual ratio (AR), using the moles calculated. Make sure that the same reactant is on top for both ratios.</li> </ul>
<p>AR &gt; SR, so the reactant in the denominator is limiting. Therefore, <math>C_4H_9O_3</math> is limiting.</p>	<ul style="list-style-type: none"> <li>Determine which reactant is limiting. If AR &gt; SR, the reactant on the bottom is limiting. If SR &gt; AR, the reactant on the top is limiting.</li> </ul>
$n(C_8H_9NO_2) = n(C_4H_9O_3)$ $n(C_8H_9NO_2) = 0.00392 \text{ mol}$	<ul style="list-style-type: none"> <li>Use the moles of the limiting reactant to calculate the number of moles of the product that can be produced.</li> </ul>
$m = nM$ $m(C_8H_9NO_2) = 0.00392 \times 151.163 = 0.593 \text{ g}$	<ul style="list-style-type: none"> <li>Use the number of moles of the product to calculate the mass of the product that can be produced.</li> </ul>
<p>Mass of paracetamol is 0.593 g.</p>	

#### TRY THESE YOURSELF

- What mass of ammonia can be produced from 5.0 L of hydrogen gas and 3.0 L of nitrogen gas at standard temperature and pressure (STP)?
- What mass of sulfur trioxide can be produced from 1 kg of sulfur dioxide and 1 kg of oxygen gas, as per the following reaction?



## Calculating percentage yield



**Percentage yield**  
For more information  
about percentage  
yield

The actual yield is usually given as a percentage of the possible yield. A yield of 90 per cent means that only 90 per cent of the amount of products that can be theoretically produced from the reactants is produced. To calculate this percentage, you need to use stoichiometry to calculate the amount of product that can theoretically be formed from the reactants and know the amount of product actually produced.

Then calculate the **percentage yield**:

$$\text{Percentage yield} = \frac{\text{Actual mass}}{\text{Theoretical mass}} \times 100$$

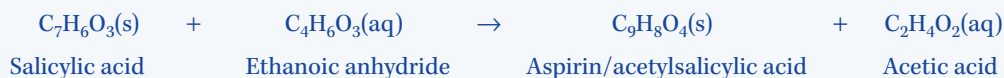
### WORKED EXAMPLE 16.2

If 5.0 g of sulfur reacts with excess oxygen to produce 7.50 g of sulfur dioxide, what is the percentage yield for the reaction?

ANSWERS	LOGIC
$\text{S(s)} + \text{O}_2(\text{g}) \rightarrow \text{SO}_2(\text{g})$	<ul style="list-style-type: none"> <li>Write a balanced equation.</li> </ul>
$n = \frac{m}{M}$ $n(\text{S}) = \frac{5.0}{32.06} = 0.156 \text{ mol}$ $n(\text{SO}_2) = 0.156 \text{ mol}$ $m = n \times M$ $m(\text{SO}_2) = 0.156 \times (32.06 + 2 \times 16)$ $= 9.99 \text{ g}$ <p>This is the theoretical yield or mass.</p>	<ul style="list-style-type: none"> <li>Calculate the amount of product that can theoretically be produced from the reactants.</li> </ul>
$\text{Percentage yield} = \frac{\text{Actual mass}}{\text{Theoretical mass}} \times 100$ $= \frac{7.50}{9.99} \times 100$ $= 75.1\%$	<ul style="list-style-type: none"> <li>Calculate the percentage yield using the theoretical yield or mass that you have calculated and the actual yield or mass given in the question.</li> </ul>

### TRY THESE YOURSELF

1 The synthesis of aspirin (acetylsalicylic acid) involves the reaction:



If 25.0 g of acetylsalicylic acid is produced when 30.0 g of salicylic acid reacts, calculate the percentage yield for the reaction.

2 The production of ammonia in the Haber process is typically carried out at approximately 450°C and 200 atm. At this temperature and pressure, 35.0 L of nitrogen gas produces 1.50 kg of ammonia. Calculate the percentage yield for the reaction.

## INVESTIGATION 16.1

### Determining percentage yield of carbon dioxide

#### INTRODUCTION

Carbon dioxide is produced during the reaction between calcium carbonate and hydrochloric acid. In an open test tube, this gas will escape the solution and the mass lost will be reflected in the loss of mass of the solution. Using this understanding, you can measure the mass of carbon dioxide produced and thus the percentage yield for the reaction.

#### AIM

To determine the percentage yield of carbon dioxide in the reaction between calcium carbonate and hydrochloric acid.

#### MATERIALS

- Calcium carbonate chips (approximately 2 g)
- 0.5 mol L<sup>-1</sup> hydrochloric acid
- 2 × 50 mL beaker
- 10 mL pipette
- Pipette filler
- Electronic balance
- Spatula
- Test-tube rack
- Safety glasses

WHAT ARE THE RISKS IN DOING THIS INVESTIGATION?	HOW CAN YOU MANAGE THESE RISKS TO STAY SAFE?
Chemicals could splash onto your skin or into your eyes.	Wear safety glasses and wash your hands at the end of the experiment.
0.5 mol L <sup>-1</sup> HCl is corrosive to skin and clothing.	Wear gloves, safety glasses and an apron.



What other risks are associated with your investigation? How can you manage these?

#### METHOD

- 1 Weigh approximately 2 g of calcium carbonate chips. Record the actual mass.
- 2 Accurately measure 10 mL of 0.5 mol L<sup>-1</sup> hydrochloric acid with a pipette.
- 3 Pour the acid into the beaker.
- 4 Accurately measure the mass of the acid and beaker.
- 5 Add the calcium carbonate chips to the acid and record any observations.
- 6 When there is no longer any visible reaction, weigh the beaker and its contents.
- 7 If there is time, repeat the experiment or collate your class' results.

#### RESULTS

Record your results in a suitable table. If you are doing multiple trials or collating the class results, ensure that you include space for all trials as well as the average.

#### ANALYSIS OF RESULTS

- 1 Write a balanced equation for the reaction.
- 2 Calculate the number of moles of each reactant used in the reaction.
- 3 Determine which reactant was the limiting reactant. Did your observations support this?
- 4 Calculate the mass of carbon dioxide that would theoretically be produced from the reactants.
- 5 Use your results to calculate the mass of carbon dioxide actually produced in your experiment.
- 6 Calculate the percentage yield for the reaction.



## » DISCUSSION

- 1 What assumption was made in determining the mass of carbon dioxide produced in this reaction?
- 2 Suggest some reasons why the reaction was not 100 per cent efficient.
- 3 What were some areas where errors or inaccuracies may have occurred during the experiment?
- 4 Suggest some ways to improve the method.

## CONCLUSION

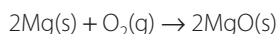
What did you conclude regarding the percentage yield in the production of carbon dioxide in this reaction?

# INVESTIGATION 16.2

## Calculating the percentage yield of magnesium oxide

### INTRODUCTION

To calculate the percentage yield for a reaction, it is necessary to be able to measure the amount of product produced from a known amount of reactants. In this investigation, you will design and conduct an experiment to determine the percentage yield of the reaction between magnesium and oxygen, as per the following reaction:



### AIM

Write an aim for your investigation.

### HYPOTHESIS

Write a suitable hypothesis for this investigation.

### MATERIALS

Carefully plan what you will need to conduct the investigation. List the items in detail, making note of the size, quantity, type and concentration where applicable.

Complete a risk assessment for your investigation.



WHAT ARE THE RISKS IN DOING THIS INVESTIGATION?	HOW CAN YOU MANAGE THESE RISKS TO STAY SAFE?

Carefully consider the risks associated with the investigation. Find the SDS for any chemicals and consider the appropriate actions to minimise any risks. Complete the table above and get your teacher's approval before conducting the investigation.

### METHOD

List the steps that you will take during the investigation. Ensure your steps are clear, concise and detailed.

### RESULTS

- 1 Ensure that you collect all the necessary data needed to be able to fulfil your aim of calculating the percentage yield.
- 2 Prepare a table to effectively organise the data that you collect during the investigation.



## » ANALYSIS OF RESULTS

List the steps that you will take to use the data that you have collected. Ensure your calculations are clear, correct and that they allow you to determine the percentage yield.

What is the percentage yield for the reaction between magnesium and oxygen?

### DISCUSSION

- 1 How could you improve your method to obtain more accurate results?
- 2 What could you do to further investigate the percentage yield for this reaction?

### EXTENSION

What other reactions could you investigate the percentage yield of? What factors may limit the reactions that you could investigate?

## Determining purity

While percentage yield is important in determining the quantity of the required product, purity is important in measuring the quality of the final product. There are a number of levels of purity that need to be considered when determining the use of the product. These include:

- technical grade – products used of non-critical laboratory tasks including rinsing, dissolving and as raw materials
- synthesis reagents – suitable for organic synthesis
- for analytical purposes – suitable for quantitative analysis, research and quality control
- pharmacopoeia grade – products that meet the purity requirement for the production of pharmaceuticals.

So, while a lower level of purity might be acceptable for use in the production of fertilisers, a very high level of purity would be required in the production of substances for human consumption such as pharmaceuticals and food additives.

In any chemical synthesis, it is almost impossible to achieve 100 per cent purity. In industry, there is a process of continuous sample testing to monitor the quality of the product. Instrumental methods such as mass spectrometry, NMR spectroscopy and IR spectroscopy, discussed in chapter 15, are used to monitor a product for the presence of impurities. It is important that, before sale, a product is analysed as to its percentage purity.

$$\text{Per cent purity} = \frac{\text{Mass of useful product}}{\text{Total mass of sample}} \times 100\%$$

Techniques used to determine the amount of useful product include volumetric analysis (discussed in chapter 7) and colourmetric techniques, gravimetric analysis techniques and precipitation titrations (discussed in chapter 14).

## WORKED EXAMPLE (16.3)

An aspirin tablet was analysed by titration to determine the purity of the tablet. 0.500 g of the tablet was dissolved in ethanol then titrated with a  $0.100 \text{ mol L}^{-1}$  sodium hydroxide solution. If the aspirin required 27.42 mL of sodium hydroxide to reach end point, determine the percentage purity of the sample.

ANSWER	LOGIC
$\text{C}_9\text{H}_8\text{O}_4 + \text{NaOH} \rightarrow \text{C}_9\text{H}_7\text{O}_4^- + \text{Na}^+ + \text{H}_2\text{O}$	<ul style="list-style-type: none"> <li>Write a balanced equation for the reaction.</li> </ul>
$n = cV = 0.100 \times 0.02742 = 0.002742 \text{ mol}$	<ul style="list-style-type: none"> <li>Calculate the number of moles of NaOH.</li> </ul>
Ratio = 1:1 $n(\text{aspirin}) = n(\text{NaOH}) = 0.002742 \text{ mol}$	<ul style="list-style-type: none"> <li>Use the stoichiometric ratio to calculate the moles of aspirin.</li> </ul>
$m = nM = 0.002742 \times 180 = 0.4936 \text{ g}$	<ul style="list-style-type: none"> <li>Calculate the mass of aspirin.</li> </ul>
$\% \text{ purity} = \frac{\text{mass product}}{\text{mass sample}} \times 100 = \frac{0.4936}{0.500} \times 100 = 98.7\%$	<ul style="list-style-type: none"> <li>Calculate the % purity.</li> </ul>

### TRY THESE YOURSELF

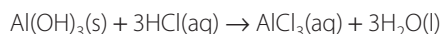
- A 6.00 g sample of a pharmaceutical product was analysed and determined to contain 5.63 g of the active drug. Calculate the percentage purity of the sample.
- A sample of magnesium hydroxide,  $\text{Mg}(\text{OH})_2$ , which was to be used in producing antacid tablets was analysed for percentage purity. 1.75 g of the sample was dissolved in water. The sample was titrated against a  $1.3 \text{ mol L}^{-1}$  solution of HCl. If the sample required 45.3 mL of HCl, calculate the percentage purity of the sample.

- Designing chemical synthetic processes involves choosing reactants and conditions to maximise yield.
- Synthesis reactions are chosen to maximise the yield and purity of the product.
- The yield of a chemical synthesis can be calculated by comparing the stoichiometric quantities with the actual quantities.
- Purity of a sample is an important aspect in its use. Samples need to be analysed to determine percentage purity and for the identification of impurities.

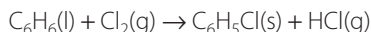
## CHECK YOUR UNDERSTANDING

16.3

- What is the difference between the rate of the reaction and the yield of the reaction?
- Where should equilibrium lie to maximise the yield of the reaction?
- What is the maximum yield that is possible for a reaction?
- Why is it important to remove the product to maximise the yield of a reaction?
- Explain why higher temperatures and pressures are *not* used in the production of sulfuric acid.
  - State the two conditions used in the Haber process and justify the use of each.
- Explain why purity of a product is important.
  - List two techniques that are used to identify impurities present in a sample.
  - List two techniques that are used to determine the percentage purity of a sample.
- In the synthesis of aluminium chloride, in the reaction below, 25.0 g of aluminium hydroxide reacts with hydrochloric acid. If 20.0 g of aluminium chloride is produced, what is the percentage yield for the reaction?



- 8 Chlorobenzene is used in the production of a range of chemicals, including dyes. Its production can occur through the substitution reaction of benzene with chlorine:



Calculate the percentage yield for the reaction if 90.0 g of benzene produces 125 g of chlorobenzene.

- 9 In the synthesis of hydrochloric acid, 3.0 kg of chlorine gas is placed in a chamber with 150 g of hydrogen gas.
- Write a balanced equation for the reaction.
  - What conditions would favour a high rate of production?
  - Given that this is an exothermic reaction, what conditions would increase the yield of HCl?
  - What is the limiting reactant in this reaction?
  - Calculate the theoretical yield of HCl.
- 10 A 200 mL sample of  $0.500 \text{ mol L}^{-1}$  HCl was thought to have been contaminated with sodium carbonate. When 25.00 mL of the sample was titrated with  $0.500 \text{ mol L}^{-1}$  NaOH, 20.50 mL was required to reach the end point.
- Calculate the mass of sodium carbonate that contaminated the original sample.
  - Calculate the percentage purity of the contaminated sample (assume  $1 \text{ mL} = 1 \text{ g}$ ).

## 16.4 Issues associated with chemical synthesis

The chemical industry has significant economic, social and environmental impacts on Australia. The mining industry in Australia alone employs more than 2 per cent of the Australian population in a wide range of jobs, including engineers, chemists, truck drivers and accountants. Add to this the chemical industry that produces both household and industrial chemicals for use here and for export and the number of jobs grows.

Chemical industries contribute significantly to Australia's economy. Australia's chemical manufacturing industry alone contributes \$11 billion to the Australian economy and makes up 11.5 per cent of the manufacturing industry.

Energy is a major factor in chemical production. Most energy comes from the combustion of fossil fuels such as coal, natural gas and petroleum. Chemical companies also use hydroelectricity or other renewable energy sources where available because they can be cheaper and cause less environmental damage. For example, in Australia many companies that refine metals that require electrolysis are located in Tasmania to take advantage of the hydroelectricity available there.

Energy is used in many areas in the chemical industry. The following are listed in order of increasing energy used:

- to power machines for physical processes such as crushing and grinding
- for transporting materials in trucks, on conveyor belts or in pipes
- for heating chemicals in roasting or evaporative processes such as distillation
- for electrolysis of chemicals, either of aqueous solutions or molten solutions.

### Environmental issues

There are also significant environmental impacts that may be a direct result of the materials used in the chemical industry or as a result of use of the product; for example, the emission of carbon dioxide from the burning of fossil fuels contributes to the enhanced greenhouse effect. Waste products such as sulfur dioxide and fertiliser run-off lead to environmental problems such as **acid rain** and eutrophication of waterways, causing algal blooms. Companies in the chemical industry must combat environmental issues and have measures in place to prevent chemical spills and accidents.

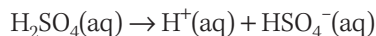
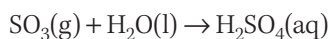
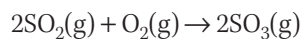


Industrial production of a chemical



## Consequences of acid rain

Acid rain is produced when waste products of industry are released into the atmosphere where they react with water to form acids. Although fossil fuels are composed of mainly carbon and hydrogen they may also contain impurities such as sulfur. Burning fossil fuels produces sulfur oxides. These react with water to form sulfuric acids, as shown in the equations below:

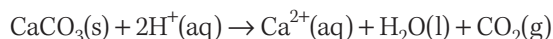


When acid rain falls, it can have an impact on both the human-built and natural environments. One of the biggest problems occurs in aquatic environments. Acid rain makes its way into rivers, lakes and other waterways through draining systems and run-off from the land. Lakes and rivers can become acidic, which has consequences for the aquatic life they contain.

Many soils contain negatively charged silicate ions. These bind to ions in the soil. Some of these ions are useful, such as magnesium and potassium, but others are harmful, such as aluminium. When acid rain falls, the hydrogen ions in the rain displace the ions from the soil silicates and the harmful ions are free to wash into waterways.

Low pH and aluminium ions in waterways have many negative effects. Some plants and animals can tolerate acidic conditions, but many are sensitive to changes in pH. The eggs and young of aquatic animals are particularly sensitive to low pH and the presence of aluminium ions. At pH 5 or less, fish eggs will not hatch. If the pH is lower than this, adult fish are directly affected and will die.

Crustaceans with calcium carbonate exoskeletons are affected by acid levels because the acid reacts with the calcium carbonate to soften and potentially destroy their shells, leaving them defenceless. The chemical reaction for this is:



Ecosystems are affected when some organisms die off. Animals that rely on these organisms for food suffer, and these effects continue through all organisms in the surrounding ecosystem.



**FIGURE 16.14** Damage to trees due to acid rain

Acid rain also affects trees. Growth rates slow, leaves turn brown and photosynthesis stops. The acid in the soil releases toxic ions such as aluminium, as described above. Aluminium affects tree growth by blocking the uptake of nutrients through the roots. In severe cases, entire areas of forest in Europe and North and South America have died off due to acid rain in those areas. You can see this damage in Figure 16.14.

Structures built by human-hands are also affected. Limestone and marble buildings in Europe have been severely affected from decades of acid rain fall. Just like crustacean shells, the calcium carbonate of limestone and marble dissolves as the acid rain falls.

## Chemical spills

The major environmental issue in the production, transport, use and storage of these chemicals is what happens in case of a spill. Spills can be caused by fires, explosions, leaks or damage to transport vehicles or storage tanks.

One of the worst chemical spills was the Bhopal disaster that occurred in India. In December 1984, a gas leak occurred at the Union Carbide India pesticide plant. Half a million people were exposed to methyl isocyanate and other gases. Methyl isocyanate is a toxic chemical that causes problems when inhaled or when skin contact occurs. People exposed can suffer chest pains and chemical burns. At high concentrations, it can cause pulmonary oedemas, haemorrhages and death.



Investigating a major  
chemical spill

An official death toll from this disaster has never been fully confirmed, but the deaths numbered at least 3000, with reports of up to 8000 people dying as a result of chemical exposure. Tens of thousands of people suffered chemical burns and other injuries.

The Bhopal disaster resulted in emergency plans being reviewed and, in many cases, implemented all over the world. In the United States, an *Emergency Planning and Community Right-to-know Act* was implemented that requires companies to provide information about the chemicals they are using, storing and transporting and to submit plans for spills, leaks and other emergencies. Today, these plans and laws are commonplace all over the world.

## Addressing environmental issues

There is now an increasing amount of legislation that regulates the chemical industry with respect to environmental issues. The treatment and disposal of waste generated is a major issue that is being addressed in a number of ways. The use of new chemical processes and clean technologies is helping to reduce the amount of waste produced.

Waste must now be treated and can only be disposed of when it is not harmful to the environment. For example, liquid wastes from chemical plants must meet legislation requirements before being released in sewage systems or waterways. Gases containing contaminants are passed through scrubbers that are designed to remove the majority of the contaminant before being released into the atmosphere.

There is also a movement, called **green chemistry**, where the aim is to reduce the impact of chemistry on the environment.

## Green chemistry

Green chemistry is a relatively new area of chemistry that aims to reduce the impact of chemistry on the environment by reducing or eliminating the use or production of hazardous substances. As you learn more about the impact of chemicals on the environment, the importance of green chemistry becomes more evident.

Green chemistry requires that all aspects of chemical production be analysed to ensure that nothing potentially harmful is used or produced. This adopts the philosophy of 'prevention is better than cure'. Previously, additional steps were used to deal with the hazardous chemicals after their production. Green chemistry means that they are not produced in the first place.

The idea of green chemistry originated with the *US Federal Pollution Prevention Act* in 1990. Their identifying logo is shown in Figure 16.15. This Act included a hierarchy associated with pollution to:

- 1 prevent pollution
- 2 treat chemicals to make them safe prior to disposal
- 3 dispose of untreated chemicals safely.

If it is not possible to achieve the first point in the hierarchy, then you move to the next point. If this is not possible, then the third point is followed. More specifically, when designing a process, the aim is to ensure there is no pollution. If hazardous chemicals are produced, then they should be treated before they are disposed of. If it is not possible to treat the chemicals, then they should be disposed of in a safe manner.



**FIGURE 16.15** The United States Environmental Protection Agency's logo for green chemistry

- Green chemistry reduces the impact of chemistry on the environment by reducing or eliminating hazardous chemicals.

- 1 Explain why the chemical industry is important.
- 2 Assess the environmental impact of the chemical industry.
- 3 Describe measures that can be taken to reduce the environmental impact of the chemical industry.
- 4 Define 'green chemistry'.
- 5 Discuss the importance of green chemistry and the implications if it is not used during synthesis reactions.

## 16.5 Green polymers – a case study in greening the plastics industry

Most synthetic polymers are made from raw materials derived from crude oil, which is a non-renewable resource. The world's oil reserves are being depleted, with analysts predicting that supplies will be effectively used up by the middle or end of this century. The other major problem is plastic pollution due to poor recycling habits of developed countries and the throwaway nature of the plastic products, including electronics and appliances.



**FIGURE 16.16** Polymers can be made using cellulose from plants.

The major use of crude oil is as fuel. Scientists are looking at possible alternatives given the concern of diminishing supplies and rising costs. Similarly, some scientists argue that alternative sources of raw materials for plastics should be developed. They point to ethanol, already being used as a fuel supplement or alternative, as being a source of ethylene, a major monomer itself and the starting point for making many other monomers for common polymers.

Others argue that as oil supplies diminish, costs will increase and oil will become too expensive as a fuel. The plastic industry will be less affected by the price rises (because the cost of the raw materials is a smaller proportion of the cost of the finished product)

and so will still be able to use oil. Consequently, these people argue that the remaining oil will become the exclusive domain of the plastic industry and will last for many more decades.

Regardless of which argument is correct, it would be prudent for the plastic industry to develop alternative sources of its core monomers – ethylene and propene.

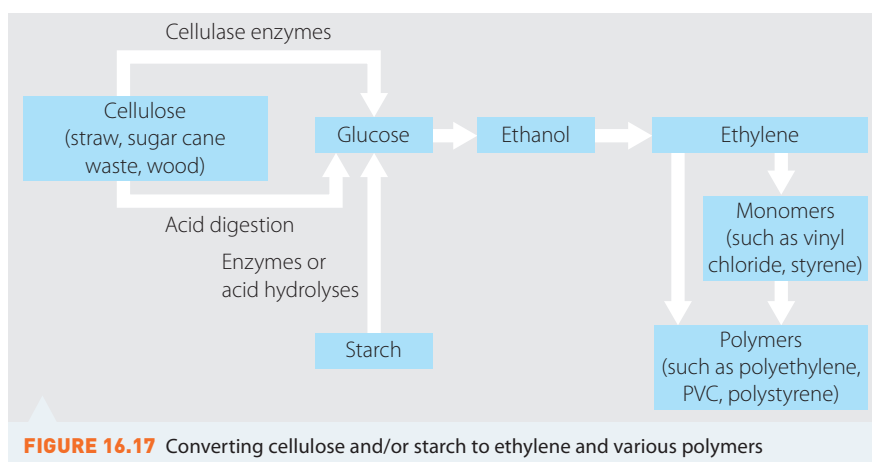
Ethanol is the prime candidate for such an alternative source of ethylene. Ethanol can be produced from fermentation of starches and sugars. These may be derived from a variety of agricultural crops, not just grapes, and the ethanol can be easily converted to ethylene.

However, another starting material increasingly being used for making many of today's polymers is cellulose. Cellulose is a major component of plant material, comprising up to 33 per cent of all vegetable matter, such as from cereal crops (Figure 16.16), whereas starch and sugars are only minor components. It is a naturally occurring condensation polymer – a polysaccharide made up of 3000 or more monomer units of glucose.

## Cellulose as a source of chemicals

Cellulose is widely used as cotton, particularly for textiles, and as paper and cardboard. But can it be used as a source of chemicals?

Each glucose unit of cellulose has six carbon atoms joined together, so it could be regarded as a basic structure for starting molecules for petrochemicals – molecules such as ethylene (2 C atoms), propylene (3 C atoms) and butane (4 C atoms, a starting point for synthetic rubber).



**FIGURE 16.17** Converting cellulose and/or starch to ethylene and various polymers

The flow chart in Figure 16.17 shows how cellulose could be converted to ethylene, which could be used to make many of the polymers synthesised from ethylene derived from oil.

Unfortunately, it is very difficult to break cellulose into glucose. This is because the long near-linear chains of cellulose hydrogen bond to one another to form compact fibres, making it hard for chemicals to access the glucose–glucose links. However, there are two processes for breaking cellulose into glucose:

- 1 Digestion by cellulose enzymes:** These enzymes exist in bacteria present in the stomach of herbivores and in certain fungi. The process can be performed industrially by first treating the finely ground cellulose-containing materials (such as grain husks and stalks, bagasse and old newspapers) with sodium hydroxide solution (or sometimes just hot water) to swell (open up) the cellulose fibres, then digesting them with cellulose enzymes to produce a solution of glucose.
- 2 Digestion with strong acid:** This involves heating a suspension of cellulose-containing materials (those mentioned above plus wood chips) with moderately concentrated aqueous sulfuric acid solution, which breaks cellulose into glucose. Insoluble matter, particularly lignin from wood pulp, is filtered off, many impurities are removed, and then the acid is neutralised to produce a solution of glucose.

In both cases, the solution of glucose can be treated with yeast to form ethanol, which can be dehydrated to ethylene if necessary.

While this conversion of cellulose to ethanol and then ethylene does work, much of the energy required for the process (keeping reaction mixtures hot and driving the process machinery) can originate from oil, so more oil would be used making ethylene this way than is used by cracking the oil directly to ethylene. Making ethanol from cellulose is considerably more expensive than making it from starch or sugars, despite the lower cost of the starting cellulose-containing material. Nevertheless, considerable scientific effort is being directed into developing more efficient ways of using cellulose as an alternative source of the chemicals currently obtained from oil.

There is also the potential for algae grown in controlled large-scale environments to produce oils that can be converted to hydrocarbons and ethanol; hence, be used as the raw materials for polymers. The advantage of algae, compared to plant crops, is that they grow very quickly and can be harvested within a week.

As well as using alternative starting materials for polymers, the chemical can reduce the amount of raw material needed to produce polymers by recycling.



## Biopolymers – polymers from nature

**Biopolymers** are polymers that are made totally or in large part by living organisms.

Originally, the word referred to biologically synthesised polymers such as cellulose, starch, proteins and nucleic acids. However, now it includes polymers that are chemically modified versions of natural polymers and polymers that can be produced by ‘manipulating’ biological organisms.

Partially synthetic biopolymers based on cellulose have been used commercially for nearly a century. The first plastic was cellulose nitrate, patented in 1869 as celluloid; it was a synthetically modified cellulose.

Some examples of renewable polymers and what they can be made from are shown in Table 16.1.

**TABLE 16.1** Renewable polymers

POLYMER	CROP OR RENEWABLE MATERIAL	COMMON USES
Starch-based polymers	Wheat, potatoes, corn	Compost bags, foam packaging fill, some food packaging
Poly(lactic acid) (PLA)	Wheat, potatoes, corn	Food packaging, medical applications
Cellulose	Farmed wood	Cereal bar wrappers
Poly(hydroxyalkanoates) (PHA)	Plant-derived sugars and oils	Medical devices such as orthopaedic pins
Polyesters	Corn	Textiles
Polyurethane	Soy or castor oil	Car seats
Polyethylene	Sugar cane	Resins

## Biodegradable synthetic plastics

One major problem with synthetic polymers compared to natural polymers is that they are not biodegradable. This means that the plastics discarded into the environment or put into rubbish dumps are not decomposed naturally by the action of living organisms such as bacteria or fungi. Plastics comprise 4 per cent by volume of landfill and, while natural polymers eventually decompose, the synthetic polymers stay around, contributing to nothing but problems in the environment, as can be seen in Figure 16.18.

One solution to this is to make plastics that are biodegradable.

Synthetic biodegradable plastic materials do exist, and have found some application in packaging. For example, a photodegradable plastic is sometimes used for six-pack can carriers but there are still

potential problems with biodegradable plastics. For example, a photodegradable plastic will not degrade if it is buried in a landfill where it is not exposed to light. When a biodegradable plastic decomposes, undesirable substances, such as mineral fillers, metal salts or other potentially dangerous additives, may enter the environment.

One approach to building biodegradability into synthetic polymers has been to alternate biopolymer sections with synthetic sections in the same polymer molecule. When the polymer is disposed of, microbes will attack the biopolymer sections, causing the polymer chain to be broken down into many smaller units. A method of doing this has already been developed.



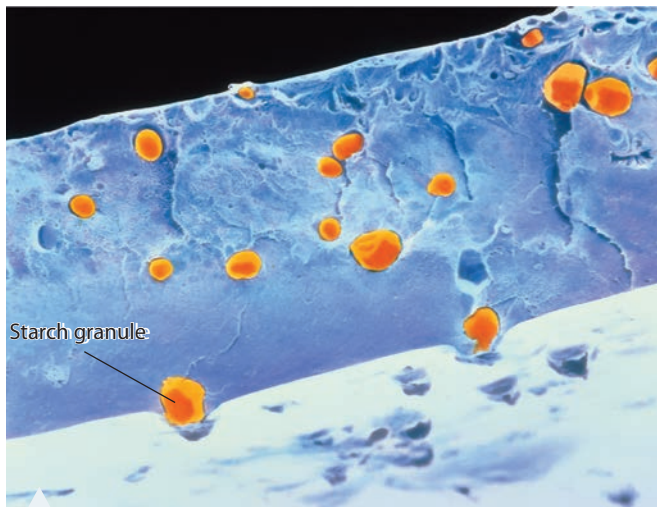
**FIGURE 16.18** Plastic rubbish in the environment

Biodegradable rubbish bags have been made using a polymer that is made up of alternating segments of starch and ethylene (Figure 16.19). It is called a 'graft copolymer'. A stronger, stiffer rubbish bag, but one that is less biodegradable, can be made using cellulose instead of starch.

Another aspect of increasing the biodegradability is to add an 'environmental trigger'. The technique being researched is to add a catalyst to the starch molecule. The idea behind this is that when the rubbish bag is dumped into the environment, microbes release the catalyst as they consume the starch. This makes the bag decompose even more quickly.

The usual biological processes should then convert the remaining fragments of polyethylene into short hydrocarbon chains. The plastics do not disappear; they are simply converted to another form of matter.

The development of biopolymers and biodegradable plastics has been one way in which chemists have designed materials in response to environmental and economic issues.



**FIGURE 16.19** Close-up of biodegradable plastic taken by a scanning electron microscope. When the plastic is disposed of, granules of starch (orange) embedded in the plastic absorb water and expand. The plastic then breaks up, increasing the area in contact with bacteria in the soil, which digest the plastic.



Check your understanding

## INVESTIGATION 16.3

### Biopolymers

#### AIM

To research a biopolymer and link its structure to its properties and use(s).

#### METHOD/DISCUSSION

- 1 Choose a biopolymer.
- 2
  - a Identify the monomer(s) that make up this biopolymer.
  - b Draw the structural formula for the monomer(s).
  - c Draw the structural formula for at least one unit of the biopolymer.
  - d Identify the properties of the biopolymer.
  - e Describe at least one use of the biopolymer and relate it to the properties of the biopolymer.
  - f Describe the properties of the biopolymer and relate them to the structure of the biopolymer.
  - g Explain whether your biopolymer can be used to replace an existing polymer produced from petrochemicals or whether it has a completely 'new' use.
- 3 Present your information as a video that can be uploaded to a class wiki or school intranet so that all members of the class can learn about different biopolymers.
- 4 Watch at least two other videos uploaded by members of your class and constructively critique the videos.

### IMPORTANT NEW TERMS

After studying this chapter you should know the meaning of the following terms:

acid rain (p. 503)

biopolymer (p. 508)

by-product (p. 493)

combustion (p. 491)

contact process (p. 491)

convergent sequence (p. 491)

enzyme (p. 496)

equilibrium (p. 492)

excess reactant/excess reagent (p. 496)

exothermic reaction (p. 494)

green chemistry (p. 505)

Haber process (p. 495)

heat of reaction (p. 494)

intermediate (p. 489)

limiting reactant/limiting reagent (p. 496)

linear sequence (p. 491)

multistep reaction (p. 490)

percentage yield (p. 498)

purity (p. 490)

reaction mechanism (p. 490)

reaction pathway (p. 488)

retrosynthetic analysis (p. 490)

synthesise (p. 488)

yield (p. 492)

### AFTER STUDYING THIS CHAPTER YOU SHOULD KNOW:

- ▶ the definitions for all terms in the important new terms list
- ▶ how and why particular chemical reagents are chosen
- ▶ synthesis reactions involve using chemical reactions to produce a specific product
- ▶ synthesis reactions can produce a wide range of products
- ▶ synthesis reactions are designed to produce the product in the most economical, safe manner
- ▶ a common method of identifying an appropriate reaction pathway and initial reactants is to use retrosynthetic analysis where you start with the desired product and work backwards by removing simple sections
- ▶ the chosen reaction mechanism or pathway should be safe, efficient and cost-effective
- ▶ most reaction pathways are multistep; often, the product from one reaction is used as a reactant for the next; these chemicals are called intermediates
- ▶ multistep reaction pathways may be linear or convergent
- ▶ how reaction conditions affect yield
- ▶ the limiting reactant is the reactant that gets used up first; the yield of a reaction is the percentage of possible product that is actually produced

- ▶ the percentage yield is calculated by dividing the actual yield by the theoretical yield and multiplying by 100
- ▶ the yield of the reaction is maximised by choosing conditions that favour the forward reaction and therefore shift equilibrium to the right
- ▶ purity is related to the percentage of active ingredient in a sample
- ▶ level of purity required varies with the end use of a product
- ▶ the contact process synthesises sulfuric acid
- ▶ the Haber process synthesises ammonia
- ▶ green chemistry is the area of chemistry that aims to reduce the impact chemistry has on the environment
- ▶ environmental, social and economic issues associated with chemical synthesis.

### YOU SHOULD BE ABLE TO:

- ▶ explain how different reaction conditions affect yield
- ▶ calculate yield, percentage yield and percentage purity
- ▶ determine limiting reagent
- ▶ describe industrial applications of chemical synthesis
- ▶ give examples of environmental, social and economic issues associated with chemical synthesis.



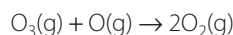
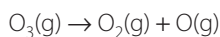
# 16 CHAPTER REVIEW QUESTIONS



Review quiz

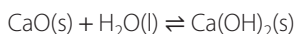
- 1 State the aim of synthesis reactions.
- 2 Define 'reaction mechanism'.
- 3 Explain how using a catalyst can improve the synthesis process.
- 4 Explain why equilibrium is important in synthesis reactions.
- 5 Why is a convergent sequence often preferred over a linear sequence?
- 6 Using an example, explain why often a compromise of reaction conditions is needed in a chemical synthesis.
- 7
  - a Explain the difference between yield and purity.
  - b Describe why each of these must be considered in a synthesis reaction.

- 8 Ozone breaks down to form oxygen gas in a two-step reaction, as follows:



Identify the reactant, intermediate and product.

- 9 The following is an exothermic reaction:



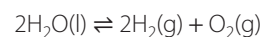
Describe the effect on the yield of the reaction if the temperature is decreased.

- 10 One step in the production of methanol involves the following reaction between methane and oxygen.  
$$2\text{CH}_4(\text{g}) + \text{O}_2(\text{g}) \rightleftharpoons 2\text{CO}(\text{g}) + 4\text{H}_2(\text{g}) \quad \Delta H = -36 \text{ kJ mol}^{-1}$$
  - a Describe the effect on the yield of carbon monoxide of:
    - i increasing the pressure of the system
    - ii increasing temperature.
  - b Explain what reaction conditions could be used to maximise yield.
  - c If 100 mL of each of methane and oxygen was added to the system:
    - i identify the reagent in excess
    - ii calculate the volume of carbon monoxide that could be produced.

- 11 Calcium carbonate ( $\text{CaCO}_3$ ) is often added to acidic wastewater from industrial synthesis to neutralise any acid present. Samples of wastewater were taken to determine the amount of calcium carbonate needed to ensure complete neutralisation. In conducting a trial, 2.5 g of calcium carbonate was added to the sample, which was determined to contain 1.0 g HCl.

- a Calculate if this was the correct amount of calcium carbonate needed.
- b Comment on the consequences of using the same relative amounts on a much larger scale.

- 12 During the production of oxygen gas by the electrolysis of water, 100 mL of water reacts, producing 65.0 g of oxygen gas:



Calculate the percentage yield of the reaction.

- 13 It was suspected that there was forgery of antique silver coins occurring. A coin thought to be a forgery was analysed for the percentage of silver. A 10.00 g sample of a coin containing silver is dissolved in excess nitric acid and the volume of the solution made up to 100.0 mL. 25.00 mL of this solution was titrated against a  $1.00 \text{ mol L}^{-1}$  sodium chloride solution. 10.45 mL was required to precipitate all the silver ions.

- a Calculate the percentage purity of the coin.
- b If the purity of the genuine coin is 90%, decide whether or not the coin analysed could be a forgery.

- 14 How might life be different if penicillin could not be manufactured by synthesis reactions?

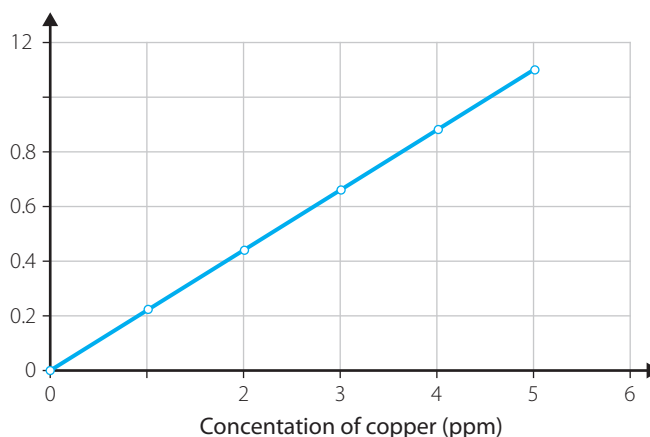
- 15 Justify why the synthesis and design of new material is important to society, giving an example.

- 16 Describe an environmental issue of a synthesis process and suggest ways in which this issue could be mitigated.

## Answer the following questions.

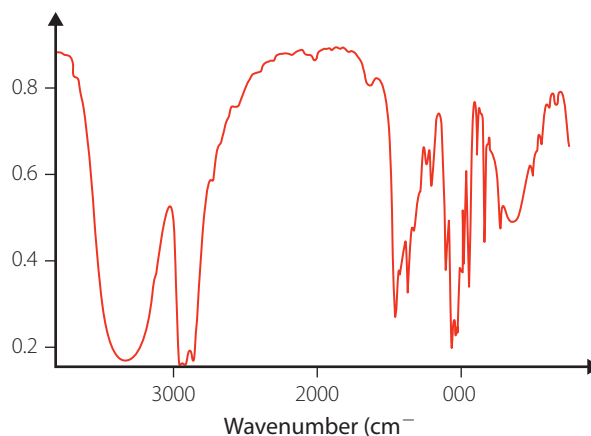
- 1 The colours produced in a flame test are caused by:
- gas in the flame absorbing some of the light emitted from the atoms.
  - electrons returning to a lower energy level after being excited by the energy from the flame.
  - atoms in the flame losing some of their electrons to become ions.
  - atoms of the substance being tested colliding with gas atoms in the flame, causing the gas atoms to emit light.
- 2 What flame colours are produced by calcium ion in a flame test?
- Red
  - Blue
  - Green
  - Orange
- 3 When using mass spectroscopy, the relative masses of particles is determined by:
- the difference in velocity of the particles.
  - the force by which the particles hit the detector.
  - the different deflection of positive and negative particles.
  - the path followed depending on the charge and mass of the particle.
- 4 Methanol is prepared commercially according to the following reaction:
- $$\text{CO(g)} + 2\text{H}_2\text{(g)} \rightleftharpoons \text{CH}_3\text{OH(g)} \quad \Delta H = -92 \text{ kJ mol}^{-1}$$
- The reaction is carried out at a temperature of 400 °C in the presence of a catalyst. Which of the following would increase the yield of methanol?
- Decrease the pressure at which the reaction is carried out.
  - Add more catalyst to the reaction mixture.
  - Increase the pressure at which the reaction is carried out.
  - Decrease the temperature at which the reaction is carried out.
- 5 There was concern that vegetables grown near a copper refinery had absorbed a dangerous level of copper from the soil. A vegetable sample was analysed using atomic absorption spectroscopy to determine the amount of copper present. The absorbance of the sample was found to be 0.6.

The calibration curve below shows the absorbance for various concentrations of copper.



What was the concentration of copper in the vegetable sample?

- $4.3 \times 10^{-2} \text{ mol L}^{-1}$
  - $2.7 \times 10^{-3} \text{ mol L}^{-1}$
  - $4.3 \times 10^{-5} \text{ mol L}^{-1}$
  - $7.0 \times 10^{-5} \text{ mol L}^{-1}$
- 6 The diagram shows the infrared spectrum of a compound.



Which of the following compounds would produce a spectrum to match the one above?

- Butane
- Butanol
- Butanoic acid
- Butanal

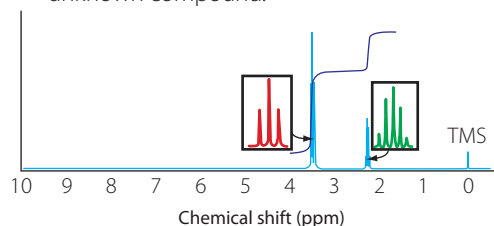
- 7 Three unlabelled bottles of organic liquids were tested to determine the contents of the bottles. The following table gives the results of the tests.

LIQUID	SODIUM METAL ADDED	BROMINE WATER ADDED	ACIDIFIED POTASSIUM PERMANGANATE ADDED
I	Gas evolved	No reaction	No reaction
II	No reaction	Decolourised	Decolourised
III	Gas evolved	No reaction	Decolourised

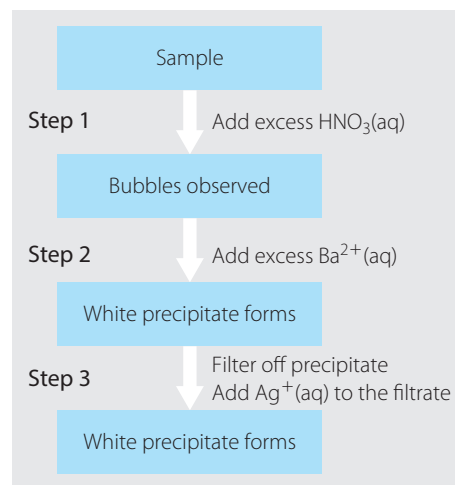
Based on the results of the test, which is the best possible identification of the three liquids?

- A I – alcohol, II – alkene, III – carboxylic acid  
 B I – alkene, II – carboxylic acid, III – alcohol  
 C I – carboxylic acid, II – alkene, III – alcohol  
 D I – alkene, II – alcohol, III – carboxylic acid
- 8 Students were given a project in which they were asked produce a dry sample of caffeine extracted from tea. Before handing in the sample for assessment, students wanted to check the sample was pure and dry. The most effective check would be produced from:
- A an IR spectrum.  
 B a mass spectrum.  
 C a UV–vis spectrum.  
 D a volumetric titration.
- 9 Hydrated aluminium chloride contain the complex ion  $[\text{Al}(\text{H}_2\text{O})_6]^{3+}$ . Which of the following statements is the most correct explanation of the bond formed between the  $\text{Al}^{3+}$  ion and the water molecules?
- A The  $\text{Al}^{3+}$  ion is attracted to the negative water molecule.  
 B The water molecule donates a lone pair of electrons to an empty orbital of the  $\text{Al}^{3+}$  ion.  
 C Hydrogen bonding is formed between the  $\text{Al}^{3+}$  ion and the water molecule.  
 D Bonding is due to dispersion forces only.
- 10 A few drops of dilute sodium hydroxide solution are added to a solution containing an unknown cation. A green precipitate is produced that gradually turns brown. The cation most likely to be present in the solution is which of the following?
- A  $\text{Ag}^+$   
 B  $\text{Mg}^{2+}$   
 C  $\text{Fe}^{2+}$   
 D  $\text{Fe}^{3+}$

- 11 a Using an example, explain why it is important to monitor the environment.  
 b An unknown compound was found in a sample of river water. Analysis showed it contained 17.84% C, 71.19% Br and the remainder was H. The mass spectrum showed the parent peak at  $m/z$  value of 200.
- Calculate the molecular formula of the compound.
  - Why would there also be peaks at  $m/z$  202 and 204?
  - Examine the  $^1\text{H}$  NMR spectrum of the compound below and suggest a chemical structure for the unknown compound.



- 12 The flow chart below shows a series of tests that can be used to identify carbonate, chloride and sulfate ions present in a sample. Explain why the analysis must be performed in the sequence given.



- 13** A student was given five solutions and told each contained one of the following cations:  $\text{Ag}^+$ ,  $\text{Pb}^{2+}$ ,  $\text{Cu}^{2+}$ ,  $\text{Ba}^{2+}$ ,  $\text{Mg}^{2+}$ ,  $\text{Ca}^{2+}$ ,  $\text{Fe}^{2+}$ ,  $\text{Fe}^{3+}$ . The results of a series of tests that were conducted are given below.

REAGENT ADDED	A	B	C	D	E
KCl	NP	NP	White ppt	NP	White ppt
$\text{H}_2\text{SO}_4$	White ppt	NP	NP	NP	White ppt
NaOH	White ppt	Brown ppt	Brown ppt	White ppt	White ppt

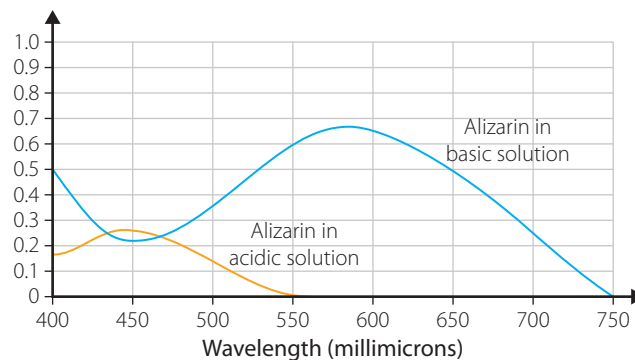
NP – no precipitate; ppt – precipitate formed

- a** Use the given results to identify possible cations for A–E. If there is not enough information, suggest other possible tests and their expected results that could be used to identify any still unknown solutions.
- b** For which of the possible cations would a flame test not be useful?
- c** The student was given another solution and was told it contained  $\text{Cu}^{2+}$ ,  $\text{Ba}^{2+}$  and  $\text{Mg}^{2+}$ . Design a procedure the student could use to separate the three cations.
- 
- 14 a** A certain brand of foot powder used to deodorise feet and to prevent fungal infections contained zinc. The zinc in a 1.080 g sample of the powder was precipitated as the double salt,  $\text{ZnNH}_3\text{PO}_4$ . This salt was strongly heated, producing 0.3680 g of  $\text{ZnP}_2\text{O}_7$ . Calculate the percentage by mass of zinc in the foot powder.
- b** Predict the effect, if any, on the experimental value of the percentage of zinc if the conversion of  $\text{ZnNH}_3\text{PO}_4$  to  $\text{ZnP}_2\text{O}_7$  was incomplete.
- 
- 15** A sample of drinking water was analysed using Volhard's method to determine the amount of chloride ions present. Chlorides are generally limited to a maximum of 250 mg/L in drinking water. A 20 mL sample is mixed with 30 mL of  $0.014 \text{ mol L}^{-1}$   $\text{AgNO}_3$  solution. The sample is back titrated with a  $0.10 \text{ mol L}^{-1}$  thiocyanate solution. The average amount of thiocyanate used is 3.3 mL.
- a** Calculate the concentration of chloride ions in the sample.
- b** Comment on whether the concentration is within the maximum guidelines value.
- 
- 16** A colourimetric analysis was conducted to determine the amount of iron in a sample. Standard samples of iron(II)-phenanthroline ( $\text{C}_{12}\text{H}_8\text{N}_2$ ), which is a complex ion  $[(\text{C}_{12}\text{H}_8\text{N}_2)_3\text{Fe}]^{2+}$  of an orange-red colour, were prepared and their absorbance measured.

ABSORBANCE	CONCENTRATION (mg Fe/mL)
0.17	0.0010
0.33	0.0020
0.52	0.0030
0.66	0.0040
0.83	0.0050

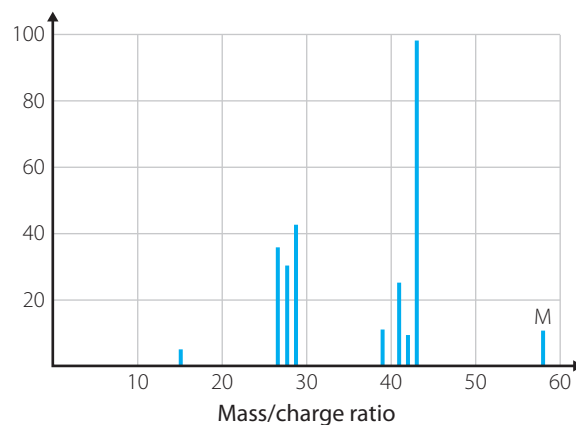
- a** Construct a calibration curve using the data in the table.
- b** Determine the concentration of iron in the unknown sample that had an absorbance of 0.59.

- 17** The dye alizarin acts as an acid–base indicator. Absorbance spectra for each colour of the dye in acidic and basic solutions is shown in the figure below.

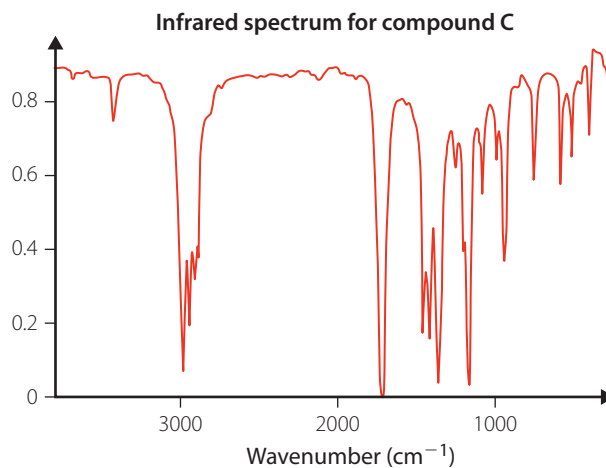
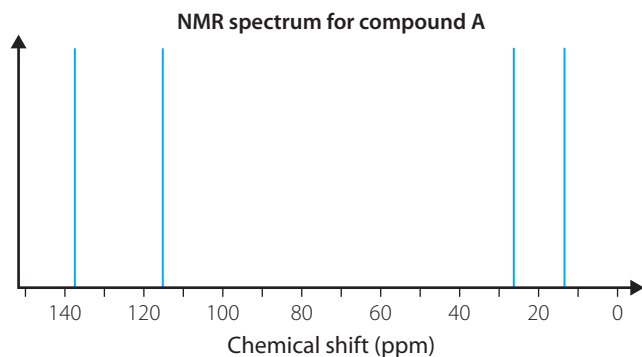
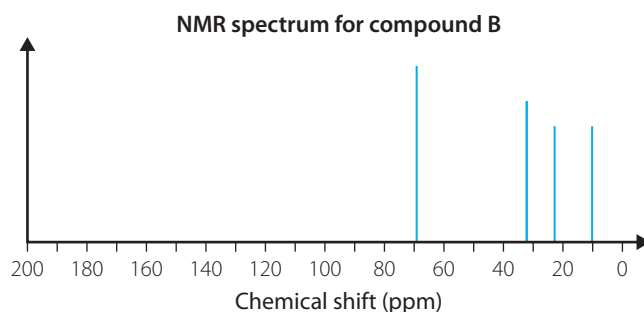
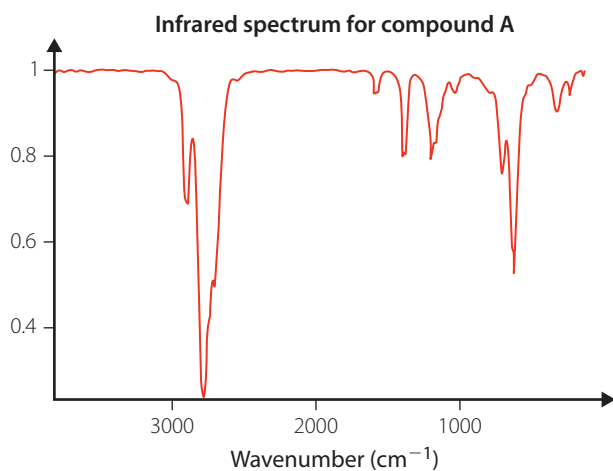
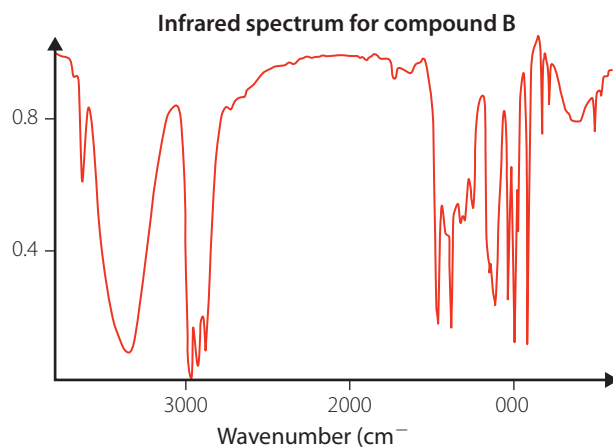


- a** Identify the best wavelength ( $\lambda_{\text{max}}$ ) for constructing a calibration graph for determining the concentration of the acidic form of alizarin.
- b** Explain why UV–vis spectrophotometry can be used.

- 18** The mass spectrum for butane is shown in the figure here.
- What species is the peak at 58 and why is it significant?
  - Account for the peaks at 15, 28 and 43.
  - Look at the peak at 43. What can you conclude about the particle responsible? Justify your answer.

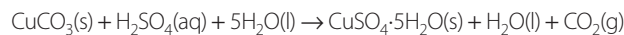


- 19** Compound A with molecular formula  $C_4H_9$  is reacted with water in the presence of a sulfuric acid catalyst to produce compound B. Compound B reacts with acidified potassium permanganate to form compound C. The infrared spectrum of compounds A, B and C are given together with the  $^{13}C$  NMR spectrum of compounds A and B.
- Identify compounds A, B and C and explain the reactions described above. For each spectrum, specify the presence or absence of at least two peaks that you used to verify the identity of each compound.



**20** A group of students were given an assignment in which they were to prepare a sample of copper(II) sulfate from copper(II) carbonate.

The reaction for the preparation was:



They reacted 2.5 g of copper carbonate with 45 mL of  $1 \text{ mol L}^{-1}$  sulfuric acid and obtained 4.6 g of the product,  $\text{CuSO}_4 \cdot 5\text{H}_2\text{O}$ . Calculate the percentage yield of the reaction.

### DEPTH STUDY SUGGESTIONS

- Conduct an investigation using colourimetry to determine the  $K_a$  of an indicator.
- Research the use of different analysis techniques in the wine industry.
- Conduct an investigation to identify the presence of cations and/or anions in a sample of contaminated water.
- Conduct gravimetric analysis to compare the sulfate content of different brands of fertiliser.
- Conduct an investigation to compare the effectiveness of gravimetric analysis with precipitation titration for determining the concentration of salt in saltwater.
- Research the cause and effect of an environmental issue (for example, acid rain, chemical spill, enhanced greenhouse effect).
- Research the instrumental methods used to determine blood alcohol content or detect drugs.
- Research the use of analysis techniques used in detecting artwork forgeries.
- Conduct an investigation to measure the yield from a reaction used to produce an ester.
- Research the use of a biopolymer that is replacing a synthetic polymer.
- Conduct an investigation to synthesise aspirin and then determine the purity of the product.

# Appendix 1: Peiodic table

The diagram shows a schematic periodic table with the following structure:

- Blue blocks:** A top row of 7 cells and a block of 6 rows by 6 columns below it.
- Yellow blocks:** A vertical column of 12 cells.
- Orange blocks:** A bottom row of 7 cells and a row of 6 cells above it.
- Pink blocks:** A vertical column of 12 cells on the right side, with two additional pink cells at the bottom of the yellow column.
- White block:** A large vertical rectangle on the left side.

Legend: A small horizontal row of four colored squares (orange, blue, yellow, pink) is located inside the white block.



## Appendi 2: Relative atomic masses (atomic weights) of common elements

ELEMENT	SYMBOL	RELATIVE ATOMIC MASS
Aluminium	Al	2698
Antimony	Sb	12175
Argon	Ar	3995
Arsenic	As	7492
Barium	Ba	13734
Beryllium	Be	901
Bismuth	B	20898
Boron	B	1081
Bromine	Br	7990
Cadmium	Cd	11241
Cesium	Cs	13291
Calcium	Ca	4008
Carbon	C	1201
Cerium	Ce	14012
Chlorine	Cl	3545
Chromium	Cr	5200
Cobalt	Co	5893
Copper	Cu	6355
Fluorine	F	1900
Gallium	Ga	6972
Germanium	Ge	7259
Gold	Au	19697
Hafnium	Hf	17849
Helium	He	400
Hydrogen	H	101
Indium	In	11482
Iodine	I	12690
Iridium	Ir	19222
Iron	Fe	5585
Krypton	Kr	8380
Lanthanum	La	13891
Lead	Pb	2072
Lithium	Li	694
Magnesium	Mg	2431
Manganese	Mn	5494
Mercury	Hg	20059
Molybdenum	Mo	9594

ELEMENT	SYMBOL	RELATIVE ATOMIC MASS
Neon	Ne	2018
Nickel	Ni	5871
Niobium	Nb	9291
Nitrogen	N	1401
Osmium	Os	1902
Oxygen	O	1600
Palladium	Pd	1064
Phosphorus	P	3097
Platinum	Pt	19509
Potassium	K	3910
Radium	Ra	22603
Rhenium	Re	1862
Rhodium	Rh	10291
Rubidium	Rb	8547
Ruthenium	Ru	10107
Scandium	Sc	4496
Selenium	Se	7896
Silicon	Si	2809
Silver	Ag	10787
Sodium	Na	2299
Strontium	Sr	8762
Sulfur	S	3206
Tantalum	Ta	18095
Techneium	Tc	9891
Tellurium	Te	12760
Thallium	Tl	20437
Thorium	Th	23204
Tin	Sn	11869
Titanium	Ti	4790
Tungsten	W	18385
Uranium	U	23803
Vanadium	V	5094
Xenon	Xe	13130
Yttrium	Y	8891
Zinc	Zn	6538
Zirconium	Zr	9122

## Appendix 3: Guidelines for using significant figures

When you measure quantities on instruments, the last figure in the measurement is usually uncertain. This is because of the in-built uncertainty in the instrument itself, even if you have avoided errors such as parallax error. Thus, if our electronic balance gives a reading of say, 10.514 g then you need to be aware that the last figure (4) will be uncertain. It is likely that the true mass is somewhere between 10.512 and 10.516 g.

Significant figures show how many digits in the reading are meaningful. The last figure is always deemed to be uncertain. By keeping track of the number of significant figures in all the instrumental measurements used to calculate a quantity, you can determine the extent to which your answer correctly represents the accuracy of your instruments. To reflect this accuracy, you always give your answer to the same number of significant figures as the *least accurate* data used. (If you use an even lower number of significant figures than this, then you might as well use less accurate instruments!)

### The rules

- 1 Every non-zero digit is significant. For example, 3.78 and 294 both have three significant figures.
- 2 Every zero in the middle of a reading is significant. For example, the mass reading of 10.514 g has five significant figures.
- 3 Every zero to the right of a reading is significant. For example, 31.20 has four significant figures. The exception to this is a number with no decimal point and a trail of zeros, such as 500 mL. This volume may have one, two or three significant figures. To avoid this ambiguity you must be given more information, stated in standard form. For example, if the volume is provided as  $5.00 \times 10^2$  mL then you know that it has three significant figures. If this is not clarified, you assume that it has the maximum number of significant figures.
- 4 Every zero before a number is not significant, and only shows the place value. For example, 0.005 only has one significant figure and 0.0090 has two significant figures. Again, rewriting these numbers in standard form clarifies this. (These numbers would be written as  $5 \times 10^{-3}$  and  $9.0 \times 10^{-3}$  respectively.)
- 5 For calculations involving pH, the pH is reported to the same number of decimal places as the number of significant figures in the  $[\text{H}_3\text{O}^+]$ . For example, if the  $[\text{H}_3\text{O}^+] = 0.036 \text{ mol L}^{-1}$  then the pH is 1.44. The  $[\text{H}_3\text{O}^+]$  has two significant figures, so the pH has two decimal places.

### Calculations

#### Rounding off

For rounding off an answer to a given number of significant figures, you examine the next figure on the right only. If it is 5 or more, then you round up.

#### Example

If you need to round 10.9847 to:

- four significant figures then you write 10.98 (8 is the fourth significant figure. The next figure on the right of 8 is 4, so you do not round up.)
- three significant figures, then you write 11.0. (9 is the third significant figure. The next figure on the right of 9 is 8, so you round up. Adding 1 to the 9 causes 10.9 to become 11.0.)

#### Adding or subtracting numbers

The answer cannot have more significant figures after the decimal point (i.e. decimal places) than the least accurate data.

#### Example

73251 ← three decimal places

+14 ← one decimal place therefore, this is the least accurate data

74651

This answer cannot have more than one decimal place, so must be rounded off to 74.7.

### Multiplying or dividing numbers

Again, the answer cannot have more significant figures than the least accurate data.

#### Example

$753 \times 60958 = 459$  (to three significant figures)

The least accurate figure (7.53) has three significant figures, so you round off the answer to three significant figures.

### Use of data such as relative atomic masses

Ideally, physical data such as relative atomic masses and molar volumes should be quoted to at least the same number of significant figures as the experimental data. However, physical data is not taken into account when determining the number of significant figures in the answer—only experimental data such as masses and volumes is considered.

### Advice

Data provided in a question or in a test should not be rounded off prior to its use in a calculation. For example, if  $A_r(\text{H})$  is given as 1.0, then in a calculation you write 1.0, not 1. Similarly, if a volume is given as 2.00 m, you write 20.00 in the calculation, not 20 (even though on your calculator you would only enter the number as 20). This makes the accuracy of the reading clear for the purposes of determining the number of significant figures you provide in your answer.

## Appendix 4: Common ions, ion colours, flame colours and solubilities

### Common ions

1+	1-	2-	3-
Ammonium $\text{NH}_4^+$	Nitrate $\text{NO}_3^-$	Carbonate $\text{CO}_3^{2-}$	Phosphate $\text{PO}_4^{3-}$
Hydronium $\text{H}_3\text{O}^+$	Nitrite $\text{NO}_2^-$	Sulfate $\text{SO}_4^{2-}$	
	Hydrogen carbonate $\text{HCO}_3^-$	Sulfite $\text{SO}_3^{2-}$	
	Hydrogen sulfate $\text{HSO}_4^-$	Hydrogen phosphate $\text{HPO}_4^{2-}$	
	Dihydrogen phosphate $\text{H}_2\text{PO}_4^-$	Dichromate $\text{Cr}_2\text{O}_7^{2-}$	
	Hydroxide $\text{OH}^-$	Sulfate $\text{SO}_3^{2-}$	
	Permanganate $\text{MnO}_4^-$	Tiosulfate $\text{S}_2\text{O}_3^{2-}$	
	Thiocyanate $\text{SCN}^-$		
	Hypochlorite $\text{OCl}^-$		
	Ethanoate (acetate) $\text{CH}_3\text{COO}^-$		
	Chlorite $\text{ClO}_2^-$		
	Chlorate $\text{ClO}_3^-$		
	Perchlorate $\text{ClO}_4^-$		
	Cyanide $\text{CN}^-$		

## on colour and flame colours

ION	FLAME COLOUR
Li <sup>+</sup>	Carmine (ll red)
Na <sup>+</sup>	Yellow
K <sup>+</sup>	Lght purple
Ca <sup>2+</sup>	Brick-red (orange-red)
Sr <sup>2+</sup>	Scalet (right red)
Ba <sup>2+</sup>	Ple green (pple green)
Cu <sup>2+</sup>	Bue (hades) green (others)
Pb <sup>2+</sup>	Lght blue-grey
Zn <sup>2+</sup>	Wiish green
Fe <sup>2+</sup>	Gld when very ot, the briht blue or gren turning to orange-brown
Fe <sup>3+</sup>	Orange-brown

## Sblility of ionic compounds at standard laboratory conditions (SLC)

ANION	Cl <sup>-</sup> Br <sup>-</sup> , <sup>-</sup>	S <sup>2-</sup>	OH <sup>-</sup>	SO <sub>4</sub> <sup>2-</sup>	CO <sub>3</sub> <sup>2-</sup> PO <sub>4</sub> <sup>3-</sup> SO <sub>3</sub> <sup>2-</sup>	CH <sub>3</sub> COO <sup>-</sup>	NO <sub>3</sub> <sup>-</sup>	O <sup>2-</sup>
HIGH SOLBLITY A) ≥ 01 mol L <sup>-1</sup>	Most	Group , group 2 NH <sub>4</sub> <sup>+</sup> Ba <sup>2+</sup> Sr <sup>2+</sup> Ca <sup>2+</sup>	Group , Sr <sup>2+</sup> Ba <sup>2+</sup> NH <sub>4</sub> <sup>+</sup>	Most	Group , NH <sub>4</sub> <sup>+</sup>	Most	All	Group , NH <sub>4</sub> <sup>+</sup> Ba <sup>2+</sup> Sr <sup>2+</sup> Ca <sup>2+</sup>
LOW SOBILITY S < 01 mol L <sup>-1</sup>	Ag <sup>+</sup> Pb <sup>2+</sup> Cu <sup>+</sup>	Most	Most	Ag <sup>+</sup> Pb <sup>2+</sup> Ca <sup>2+</sup> Ba <sup>2+</sup> Sr <sup>2+</sup>	Most	Ag <sup>+</sup>	None	Most

Notes on the solubility rules:

- All group 1 compounds and all ammonium compound have a high solubility in water.
- The compounds siver acetate, lead(II) chloride, calcium sulfate, silver sulfate and calcium hydroxide are sparingly soluble (that is, have a solubility range 1–10 gL<sup>-1</sup>) so may not precipitate if they are present in very low concentrations.
- Pb<sup>2+</sup> Ba<sup>2+</sup> Cu<sup>2+</sup> and Ag<sup>+</sup> will not precipitate with PO<sub>4</sub><sup>3-</sup> in solutions where pH < 2

## Appendix 5: Common units of measurement

### Common values of mass, temperature and pressure

1 tonne (1 t) =  $10^6$  g = 1 Mg

STP = 0°C and 100 kPa

SLC = 25°C and 100 kPa

0°C = 27315 K

1 atm = 101325 kPa = 760 mmHg

### Standad values

Avogadro constant  $N_A = 6022 \times 10^{23} \text{ mol}^{-1}$

Universal gas constant  $R = 831 \text{ J mol}^{-1} \text{ K}^{-1}$

Molar volume of gases at 100kPa

- 2271 L at 0 °C (27315 K)
- 2479 L at 25 °C (29815 K)

Density of water =  $100 \text{ g cm}^{-3}$  at 25°C

### Prefixes fo physical quantities

FRACTION	PREFX	SYMBOL	MULTIPLE	PREFX	SYMBOL
$10^{-1}$ (tenth)	dec	d	$10^1$ (te)	deca	da
$10^{-2}$ (hundredth)	centi	c	$10^2$ (hundred)	hecto	h
$10^{-3}$ (thousandth)	m	m	$10^3$ (thousand)	kilo	k
$10^{-6}$ (month)	mcro	$\mu$	$10^6$ (mon)	mega	M
$10^{-9}$ (bonth)	nano	n	$10^9$ (bon)	giga	G

## Appendix 6: Acid–base indicators

COMMON NAME OF INDICATOR	COLOUR OF $H_n(aq)$	APPROXIMATE pH RANGE	COLOUR OF $n^- aq$
Methylviolet	Yellow	00–16	Blue
Thymol blue	Red	12–28	Yellow
Orange IV	Red	14–28	Yellow
Benzopururine-48	Violet	22–42	Red
Congo red	Blue	30–50	Red
Methyl orange	Red	31–44	Yellow
Bromocresol green	Yellow	38–54	Blue
Methyl red	Red	44–60	Yellow
Chlorophenol red	Yellow	52–68	Red
Bromothymol blue	Yellow	62–76	Blue
Litmus	Red	60–80	Blue
Phenol red	Yellow	68–84	Red
Metacresol purple	Yellow	74–90	Purple
Thymol blue	Yellow	80–96	Blue
Phenolphthalein	Colourless	83–100	Red
Thymolphthalein	Colourless	94–106	Blue
Aizarinellow R	Yellow	101–120	Red
nigo carmine	Blue	114–130	Yellow
135-trinitrobenzene	Colourless	120–140	Orange

## Appendi 7: Relative acid strengths

PER CENT REACTION WITH WATER	AID		CONJUGATE BASE	
	NAME	FORMULA	NAME	FORMULA
100	Perchloric acid	HClO <sub>4</sub> aq	Perchlorate ion	ClO <sub>4</sub> <sup>-</sup> aq
100	Hydroiodic acid	HI(aq)	Iodide ion	I <sup>-</sup> aq
100	Hydrobromic acid	HBr(aq)	Bromide ion	Br <sup>-</sup> aq
100	Hydrochloric acid	HCl(aq)	Chloride ion	Cl <sup>-</sup> aq
100	Sulfuric acid	H <sub>2</sub> SO <sub>4</sub> aq	Hydrogen sulfate ion	HSO <sub>4</sub> <sup>-</sup> aq
100	Nitric acid	HNO <sub>3</sub> aq	Nitrate ion	NO <sub>3</sub> <sup>-</sup> aq
–	Hydronium ion	H <sub>3</sub> O <sup>+</sup> aq	Water	H <sub>2</sub> O(l)
51	Oxalic acid	HOOC-COOH(aq)	Hydrogen oxalate ion	HOOC-COO <sup>-</sup> aq
30	Sulfurous acid	SO <sub>2</sub> + H <sub>2</sub> O) H <sub>2</sub> SO <sub>3</sub> aq	Hydrogen sulfite ion	HSO <sub>3</sub> <sup>-</sup> aq
27	Hydrogen sulfate ion	HSO <sub>4</sub> <sup>-</sup> aq	Sulfate ion	SO <sub>4</sub> <sup>2-</sup> aq
23	Phosphoric acid	H <sub>3</sub> PO <sub>4</sub> aq	Dihydrogen phosphate ion	H <sub>2</sub> PO <sub>4</sub> <sup>-</sup> aq
82	Citric acid	H <sub>3</sub> C <sub>6</sub> H <sub>5</sub> O <sub>7</sub> aq	Dihydrogen citrate ion	H <sub>2</sub> C <sub>6</sub> H <sub>5</sub> O <sub>7</sub> <sup>-</sup> aq
81	Nitrous acid	HNO <sub>2</sub> aq	Nitrite ion	NO <sub>2</sub> <sup>-</sup> aq
78	Hydrofluoric acid	HF(aq)	Fluoride ion	F <sup>-</sup> aq
42	Methanoic (formic) acid	HCOO(a)	Methanoate ion	HCOO <sup>-</sup> aq
13	Ethanoic (acetic) acid	CH <sub>3</sub> COO(a)	Ethanoate (acetate) ion	CH <sub>3</sub> COO <sup>-</sup> aq
–	Carbonic acid	CO <sub>2</sub> + H <sub>2</sub> O) H <sub>2</sub> CO <sub>3</sub> aq	Hydrogen carbonate ion	HCO <sub>3</sub> <sup>-</sup> aq
010	Hydrosulfuric acid	H <sub>2</sub> S(aq)	Hydrogen sulfide ion	HS <sup>-</sup> aq
0079	Dihydrogen phosphate ion	H <sub>2</sub> PO <sub>4</sub> <sup>-</sup> aq	Hydrogen phosphate ion	HPO <sub>4</sub> <sup>2-</sup> aq
0079	Hydrogen sulfite ion	HSO <sub>3</sub> <sup>-</sup> aq	Sulfite ion	SO <sub>3</sub> <sup>2-</sup> aq
0054	Hypochlorous acid	HClO(aq)	Hypochlorite ion	ClO <sup>-</sup> aq
00078	Hydrocyanic acid	HCN(aq)	Cyanide ion	CN <sup>-</sup> aq
00076	Ammonium ion	NH <sub>4</sub> <sup>+</sup> aq	Ammonia	NH <sub>3</sub> aq
00022	Hydrogen carbonate ion	HCO <sub>3</sub> <sup>-</sup> aq	Carbonate ion	CO <sub>3</sub> <sup>2-</sup> aq
000020	Hydrogen phosphate ion	HPO <sub>4</sub> <sup>2-</sup> aq	Phosphate ion	PO <sub>4</sub> <sup>3-</sup> aq
000011	Hydrogen sulfide ion	HS <sup>-</sup> aq	Sulfide ion	S <sup>2-</sup> aq
–	Water	H <sub>2</sub> O(l)	Hydroxide ion	OH <sup>-</sup> aq



- The per cent reaction of acids with water is for 0.10 mol L<sup>-1</sup> solutions and is only valid for concentrations close to 0.10 mol L<sup>-1</sup>. All measurements of acid strengths were made under standard laboratory conditions (SLC).
- No per cent reaction is given for carbonic acid because this acid has a molar solubility of less than 0.10 mol L<sup>-1</sup> at 25°C.
- Values in this table for 25°C are taken from Dean, J. (Ed) (1991). *Lane's Handbook of Chemistry* 15th edition, McGraw-Hill.

## Appendix 8: Standard electrode potentials at 25°C

	OXIDISED FORM + $ne^-$ → REDUCED FORM	$E^\circ$ V		
Oxidising strength decreases ↑	$Li^+ + e^-$	→ L	-304	Reducing strength decreases ↓
	$K^+ + e^-$	→ K	-294	
	$Ba^{2+} + 2e^-$	→ Ba	-291	
	$Ca^{2+} + 2e^-$	→ Ca	-287	
	$Na^+ + e^-$	→ Na	-271	
	$Mg^{2+} + 2e^-$	→ Mg	-236	
	$Al^{3+} + 3e^-$	→ Al	-168	
	$Mn^{2+} + 2e^-$	→ Mn	-118	
	$2H_2O + 2e^-$	→ $H_2 + 2OH^-$	-083	
	$Zn^{2+} + 2e^-$	→ Zn	-076	
	$2CO_2 + 2H^+ + 2e^-$	→ $H_2C_2O_4$	-049	
	$Fe^{2+} + 2e^-$	→ Fe	-044	
	$Cd^{2+} + 2e^-$	→ Cd	-040	
	$PbSO_4 + 2e^-$	→ $Pb + SO_4^{2-}$	-036	
	$Co^{2+} + 2e^-$	→ Co	-028	
	$N^{2+} + 2e^-$	→ N	-024	
	$Sn^{2+} + 2e^-$	→ Sn	-014	
	$Pb^{2+} + 2e^-$	→ Pb	-013	
		$2H^+ + 2e^-$	→ $H_2$	
↑	$S_4O_6^{2-} + 2e^-$	→ $2S_2O_3^{2-}$	+008	↓
	$S + 2H^+ + 2e^-$	→ $H_2S$	+014	
	$Sn^{4+} + 2e^-$	→ $Sn^{2+}$	+015	
	$SO_4^{2-} + 4H^+ + 2e^-$	→ $SO_3^{2-} + 2H_2O$	+016	
	$Cu^{2+} + 2e^-$	→ Cu	+034	
	$Ag_2O + H_2O + 2e^-$	→ $2Ag + 2OH^-$	+034	
	$O_2 + 2H_2O + 4e^-$	→ $4OH^-$	+040	
	$I_2 + 2e^-$	→ $2I^-$	+054	
	$MnO_4^- + 2H_2O + 3e^-$	→ $MnO_2 + 4OH^-$	+060	
	$I_2(aq) + 2e^-$	→ $2I^-$	+062	
	$O_2 + 2H^+ + 2e^-$	→ $H_2O_2$	+070	
	$Fe^{3+} + e^-$	→ $Fe^{2+}$	+077	
	$Ag^+ + e^-$	→ Ag	+080	
	$NO_3^- + 2H^+ + e^-$	→ $NO_2 + H_2O$	+080	
	$Hg^{2+} + 2e^-$	→ Hg	+085	
	$2Hg^{2+} + 2e^-$	→ $Hg_2^{2+}$	+092	
	$NO_3^- + 3H^+ + 2e^-$	→ $HNO_2 + H_2O$	+093	
	$NO_3^- + 4H^+ + 3e^-$	→ $NO + 2H_2O$	+096	
	$Br_2(l) + 2e^-$	→ $2Br^-$	+108	
	$Br_2(aq) + 2e^-$	→ $2Br^-$	+110	
	$Ag_2O + 2H^+ + 2e^-$	→ $2Ag + H_2O$	+117	
	$Pt^{2+} + 2e^-$	→ Pt	+118	
	$MnO_2 + 4H^+ + 2e^-$	→ $Mn^{2+} + 2H_2O$	+122	
	$O_2 + 4H^+ + 4e^-$	→ $2H_2O$	+123	
	$O_3 + H_2O + 2e^-$	→ $O_2 + 2OH^-$	+124	
	$Cr_2O_7^{2-} + 14H^+ + 6e^-$	→ $2Cr^{3+} + 7H_2O$	+136	
	$Cl_2(g) + 2e^-$	→ $2Cl^-$	+136	
	$Cl_2(aq) + 2e^-$	→ $2Cl^-$	+140	
	$PbO_2 + 4H^+ + 2e^-$	→ $Pb^{2+} + 2H_2O$	+146	
	$MnO_4^- + 8H^+ + 5e^-$	→ $Mn^{2+} + 4H_2O$	+151	
	$Au^+ + e^-$	→ Au	+169	
	$H_2O_2 + 2H^+ + 2e^-$	→ $2H_2O$	+178	
$F_2(g) + 2e^-$	→ $2F^-$	+289		

## Note related to standard electrode potentials (Appendix 8)

State symbols (phase descriptors) have been omitted in order not to clutter up what is already a complex table. All ions are present as aqueous solutions; other substances are present in their stable pure forms at 25°C and 100 kPa.

On the large size arrows, 'oxidising strength' refers to the oxidised form of the redox couple and 'reducing strength' refers to the reduced form of the couple.

## Appendix 9: Data tables

### <sup>1</sup>H NMR data

TYPE OF PROTON	CHEMICAL SHIFT ( ppm)	TYPE OF PROTON	CHEMICAL SHIFT ( ppm)
Alkane $\text{CH}_3$	0.9	$\text{R}-\text{NH}_2$ $\text{RCH}=\text{CH}_2$	Variable, about 1.5–4 4.6–6.0
$\text{R}-\text{CH}_2-\text{R}$	1.3	$\text{R}-\text{O}-\text{CH}_3$ or $\text{ROCH}_2\text{R}$	3.3
$\text{R}-\text{C}=\text{OCH}_3$	2.1	$\text{R}-\text{OH}$	Variable, about 1–6
$\text{R}-\text{CH}_2-\text{X}$ (X = F, Cl, Br or I)	3–4	$\text{Ar}-\text{OH}$	Variable, about 4–7
$\text{CH}_3-\text{COOR}$	2.0	$\text{R}-\text{COOH}$	9–13
$\text{RCH}_2\text{OH}$ $\text{RCH}=\text{CH}-\text{CH}_3$	3.3–4.5 1.6–1.9	$\text{R}-(\text{O})-\text{H}$	9–10

### <sup>13</sup>C NMR data

TYPE OF CARBON	CHEMICAL SHIFT ( ppm)
$\text{R}-\text{CH}_3$	8–25
$\text{R}-\text{CH}_2-\text{R}$	20–45
$\text{R}_3-\text{CH}$	40–60
$\text{R}_4-\text{C}$	36–45
$\text{RCH}_2-\text{X}$	15–80
$\text{RCNH}_2$	35–70
$\text{RCH}_2-\text{O}$	50–90
$\text{RC}=\text{CR}$	110–150
$\text{RCOOH}$	160–185
$\text{RC(O)H}$ (aldehydes)	190–200
$\text{RC}=\text{O}$ in ketones)	205–220

## Infrared absorption

CLASS OF COMPOUND AND BOND	BAND POSITIONS (cm <sup>-1</sup> )
<b>ALKANES, ALKYL GROUPS</b>	
C—H	2850–3300
C—C	750–1100
<b>ALKENES</b>	
—CH	3020–3100
—C=C	1620–1680
<b>ALKYL HALIDES</b>	
C—Cl	600–800
C—Br	500–600
C—I	500
<b>ALCOHOLS</b>	
—OH	3230–3500 (strong, broad)
—C—O	1050–1150
<b>AMINES</b>	
N—H	3310–3500
C—N	1030–1230
<b>CARBONYL COMPOUNDS (SUCH AS CARBOXYLIC ACIDS, ESTERS)</b>	
C=O	1670–1780
<b>CARBOXYLIC ACIDS</b>	
—OH	2500–3100 (strong, broad)

## UV absorption

CHROMOPHORE (AND AN EXAMPLE WITH CORRESPONDING ABSORBANCE)	WAVELENGTH (λ) MAX (nm)
C—H e.g. CH <sub>4</sub>	170 173
C—X, e.g. CH <sub>3</sub> OH CH <sub>3</sub> NH <sub>2</sub> CH <sub>3</sub> I CCl CBr	180–260 187 215 258 173 208
C=C e.g. H <sub>2</sub> C=CH <sub>2</sub>	160–190 162
H <sub>2</sub> C=CH—CH=CH <sub>2</sub>	217
C=O e.g. H—CH=O	270, 170–200 270, 185
H <sub>2</sub> C=CH—CH=O	328, 208
C=N	190, 300
N=O	630–700

Source: [https://web.vscht.cz/~poustkaj/EN%20ASFA%20AU%20Kopl%3%adk%20UV\\_VIS\\_spectrometry.pdf](https://web.vscht.cz/~poustkaj/EN%20ASFA%20AU%20Kopl%3%adk%20UV_VIS_spectrometry.pdf)

## Data sheet

SOLUBILITY CONSTANTS AT 25 °C			
COMPOUND	$K_{sp}$	COMPOUND	$K_{sp}$
Barium carbonate	$258 \times 10^{-9}$	Lead(II) bromide	$660 \times 10^{-6}$
Barium hydroxide	$255 \times 10^{-4}$	Lead(II) chloride	$170 \times 10^{-5}$
Barium phosphate	$13 \times 10^{-29}$	Lead(II) iodide	$98 \times 10^{-9}$
Barium sulfate	$108 \times 10^{-0}$	Lead(II) carbonate	$740 \times 10^{-4}$
Calcium carbonate	$336 \times 10^{-9}$	Lead(II) hydroxide	$143 \times 10^{-5}$
Calcium hydroxide	$502 \times 10^{-6}$	Lead(II) phosphate	$80 \times 10^{-43}$
Calcium phosphate	$207 \times 10^{-29}$	Lead(II) sulfate	$253 \times 10^{-8}$
Calcium sulfate	$493 \times 10^{-5}$	Magnesium carbonate	$682 \times 10^{-6}$
Copper(II) carbonate	$14 \times 10^{-0}$	Magnesium hydroxide	$561 \times 10^{-2}$
Copper(II) hydroxide	$22 \times 10^{-20}$	Magnesium phosphate	$104 \times 10^{-24}$
Copper(II) phosphate	$140 \times 10^{-37}$	Silver bromide	$535 \times 10^{-3}$
Iron(II) carbonate	$313 \times 10^{-11}$	Silver chloride	$177 \times 10^{-0}$
Iron(II) hydroxide	$487 \times 10^{-7}$	Silver carbonate	$846 \times 10^{-2}$
Iron(III) hydroxide	$279 \times 10^{-39}$	Silver hydroxide	$20 \times 10^{-8}$
Iron(III) phosphate	$991 \times 10^{-6}$	Silver iodide	$852 \times 10^{-7}$
		Silver phosphate	$889 \times 10^{-7}$
		Silver sulfate	$120 \times 10^{-5}$

Aylward and Findlay, *SI Chemical Data* (5th Edition) is the principal source of data.

# STUDENT BOOK ANSWERS

## CHAPTER 2

### WORKED EXAMPLE 2.1

- spontaneous
- not spontaneous

### CHECK YOUR UNDERSTANDING 2.1/2.2

- $\text{H}_2\text{O}(\text{l}) \rightarrow \text{H}^+(\text{aq}) + \text{OH}^-(\text{aq})$
  - $\text{H}^+(\text{aq}) + \text{OH}^-(\text{aq}) \rightarrow \text{H}_2\text{O}(\text{l})$

### CHECK YOUR UNDERSTANDING 2.3

- $\text{CO}(\text{g}) + \text{Cl}_2(\text{g}) \rightleftharpoons \text{COCl}_2(\text{g})$
  - $[\text{CO}(\text{g})] = 1.0 \text{ mol L}^{-1}$ ,  $[\text{Cl}_2(\text{g})] = 1.0 \text{ mol L}^{-1}$ ,  $[\text{COCl}_2(\text{g})] = 0 \text{ mol L}^{-1}$
  - at approximately 5 minutes

### CHAPTER REVIEW QUESTIONS

- A, C (if nothing is entering or leaving the beaker)
- B
- C
- D
- Reverse reaction is favoured.
    - Will move to the right.
  - no change
    - no change
  - Reverse reaction is favoured.
    - move to the right
  - Reverse reaction is favoured.
    - move to the right
- more  $\text{NO}_2$  would be produced
  - more  $\text{N}_2\text{O}_4$  would be produced
  - shift to the right, producing more  $\text{NO}_2$ .
  - shift to the left to produce more reactant
  - The system will move in the reverse direction.
- 0–2 minutes, 3–5 minutes, 6–8 minutes and 9–12 minutes
  - Some of the  $\text{COCl}_2$  was removed from the system.
- not spontaneous

## CHAPTER 3

### WORKED EXAMPLE 3.1

- $$K_{\text{eq}} = \frac{[\text{SO}_3]^2}{[\text{SO}_2]^2 [\text{O}_2]}$$
- $$K_{\text{eq}} = \frac{[\text{CO}][\text{H}_2]}{[\text{H}_2\text{O}]}$$
- $$K_{\text{eq}} = [\text{O}_2]$$
- $$K_{\text{eq}} = \frac{[\text{SO}_4^{2-}][\text{H}_3\text{O}^+]}{[\text{HSO}_4^-]}$$
- $$K_{\text{eq}} = \frac{[\text{Cr}_2\text{O}_7^{2-}]}{[\text{CrO}_4^{2-}]^2 [\text{H}^+]^2}$$

### WORKED EXAMPLE 3.2

- $4.8 \times 10^{-2}$
- $4 \times 10^{-6}$
- $2.3 \times 10^{-6}$

### CHECK YOUR UNDERSTANDING 3.1

- $$K_{\text{eq}} = \frac{[\text{Ag}(\text{NH}_3)_2^+]}{[\text{Ag}^+][\text{NH}_3]^2}$$
  - $$K_{\text{eq}} = \frac{[\text{I}]}{[\text{Cl}_2][\text{I}_2]}$$
  - $$K_{\text{eq}} = \frac{[\text{CH}_3\text{OH}][\text{HCOOH}]}{[\text{HCOOCH}_3]}$$
  - $$K_{\text{eq}} = \frac{[\text{CH}_3\text{OH}]}{[\text{CO}][\text{H}_2]^2}$$
  - $$K_{\text{eq}} = \frac{[\text{H}_2][\text{CO}_2]}{[\text{CO}][\text{H}_2\text{O}]}$$
  - $$K_{\text{eq}} = \frac{[\text{NOCl}]^2}{[\text{NO}]^2 [\text{Cl}_2]}$$
  - $$K_{\text{eq}} = \frac{[\text{CO}][\text{H}_2]}{[\text{H}_2\text{O}]}$$

- 0.056
  - 25
- 6.2
- $4.0 \times 10^4$

### WORKED EXAMPLE 3.3

- $1.90 \times 10^{-5}$
- $2\text{COF}_2(\text{g}) \rightleftharpoons \text{CO}_2(\text{g}) + \text{CF}_4(\text{g})$
  - 144

### WORKED EXAMPLE 3.4

$0.0200 \text{ mol L}^{-1}$

### CHECK YOUR UNDERSTANDING 3.2/3.3

- Mixture A  $1.06 \times 10^{-5}$   
Mixture B  $1.06 \times 10^{-5}$   
Mixture C  $1.04 \times 10^{-5}$
  - $2.58 \times 10^{-3}$
  - no effect
  - 1.6
  - well to the right
    - well to the left
    - about in the middle
    - well to the left
    - about in the middle
    - well to the right
    - well to the left
    - well to the right
  - proceed to the left
    - proceed to the right
  - $0.27 \text{ mol L}^{-1}$
    - $0.13 \text{ mol L}^{-1}$
  - $\frac{5.06}{1}$
    - $0.137 \text{ mol L}^{-1}$
  - $[\text{PCl}_3] = [\text{Cl}_2] = 0.084 \text{ mol L}^{-1}$   
$$K_{\text{eq}} = \frac{[\text{Cl}_2][\text{PCl}_3]}{[\text{PCl}_5]}$$
  
$$0.042 = \frac{0.084 \times 0.084}{[\text{PCl}_5]}$$
  
 $[\text{PCl}_5] = 0.168 \text{ mol L}^{-1}$
    - $$K_{\text{eq}} = \frac{[\text{Cl}_2][\text{PCl}_3]}{[\text{PCl}_5]}$$
  
$$0.042 = \frac{[\text{Cl}_2][\text{PCl}_3]}{0.095}$$
  
 $[\text{Cl}_2][\text{PCl}_3] = 0.00399$   
 $[\text{Cl}_2] = [\text{PCl}_3] = 0.063 \text{ mol L}^{-1}$

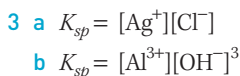
### WORKED EXAMPLE 3.7

1.10

■ CHECK YOUR UNDERSTANDING

3.4/3.5

- 1 a decrease  
b increase  
c decrease  
d increase



4 a  $K_a = \frac{[H_3O^+][OC^-]}{[HOC]}$

b  $K_a = \frac{[H_3O^+][CN^-]}{[HCN]}$

5 a  $K_b = \frac{[CH_3NH_3^+][OH^-]}{[CH_3NH_2]}$

b  $K_b = \frac{[C_6H_5NH_3^+][OH^-]}{[C_6H_5NH_2]}$

6  $K_p = \frac{P_{NO}^2}{P_{N_2O_4}}$

■ CHAPTER REVIEW QUESTIONS

3  $K_a = \frac{[CH_3COO^-][H^+]}{[CH_3COOH]}$

4 a  $K_{eq} = \frac{[NH_3]^2}{[N_2][H_2]^3}$

b  $9.1 \times 10^6$

6  $4.0 \times 10^4$

7 79

8  $8.2 \times 10^{-4}$

9  $0.033 \text{ mol L}^{-1}$

10  $94 \text{ mol L}^{-1}$

11 a not at equilibrium

b forward reaction will be favoured

12  $K_b = \frac{[NH_4^+][OH^-]}{[NH_3]}$   
 $= \frac{9.49 \times 10^{-4} \times 9.49 \times 10^{-4}}{0.0500}$   
 $= 1.8 \times 10^{-5}$

13 0.030

14 0.62

15 a  $Q = \frac{[H_2]^3 [CO]}{[CH_4]}$

b not at equilibrium

c (answer to first question) – shift to the right

d endothermic

CHAPTER 4

■ WORKED EXAMPLE 4.1

1 a 30 g/100 g water

b 40 g/100 g water

c 80 g/100 g water

2  $\text{NaNO}_3$

3 Approximately 38 g

■ CHECK YOUR UNDERSTANDING

4.3/4.4

3 a 56 g/100 g water

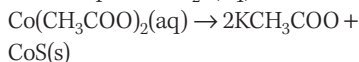
b 3 g/100 g

4 0.24 mol

■ WORKED EXAMPLE 4.2

1 Precipitate: cobalt sulfide

Neutrals species:  $\text{K}_2\text{S}(\text{aq}) +$



Net ionic:  $\text{S}^{2-}(\text{aq}) + \text{Co}^{2+}(\text{aq}) \rightarrow \text{CoS}(\text{s})$

2 a Copper(II) hydroxide ( $\text{Cu}(\text{OH})_2$ )

b No precipitate formed

c Lead sulfate ( $\text{PbSO}_4$ )

3 sodium or potassium carbonate or sodium/potassium phosphate to form calcium carbonate or calcium phosphate

■ CHECK YOUR UNDERSTANDING 4.5

1 the solid formed when two ionic solutions are mixed

2 an ion that is not involved in a reaction

3 a, c, d and e

4 a Potassium nitrate and zinc chloride

b Ammonium carbonate and sodium sulfate

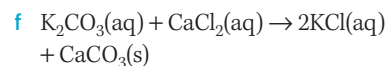
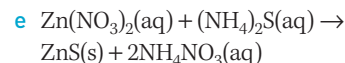
c Magnesium sulfate and copper(II) bromide

5 a  $\text{NaCl}(\text{aq}) + \text{AgNO}_3(\text{aq}) \rightarrow \text{AgCl}(\text{s}) + \text{NaNO}_3(\text{aq})$

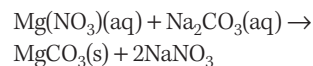
b  $\text{CuSO}_4(\text{aq}) + 2\text{KOH}(\text{aq}) \rightarrow \text{Cu}(\text{OH})_2(\text{s}) + \text{K}_2\text{SO}_4(\text{aq})$

c NR

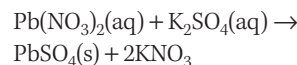
d  $\text{Na}_2\text{CO}_3(\text{aq}) + \text{FeSO}_4 \rightarrow \text{Na}_2\text{SO}_4(\text{aq}) + \text{FeCO}_3(\text{s})$



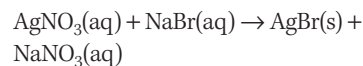
6 a Magnesium nitrate and sodium carbonate



b Lead nitrate and potassium sulfate



c Silver nitrate and sodium bromide



7 B

8 a Add sodium hydroxide.

b There is no precipitate test you can do.

■ WORKED EXAMPLE 4.3

1  $K_{sp} = [\text{Ca}^{2+}] \times [\text{CO}_3^{2-}]$

2  $K_{sp} = [\text{Pb}^{2+}] \times [\text{Cl}^-]^2$

3  $K_{sp} = [\text{Mg}^{2+}]^3 \times [\text{PO}_4^{3-}]^2$

■ CHECK YOUR UNDERSTANDING 4.6

3 a no equilibrium expression

b equilibrium expression can be written

c equilibrium expression can be written

d no equilibrium expression

e equilibrium expression can be written

f equilibrium expression can be written

g equilibrium expression can be written

4 a  $K_{sp} = [\text{Zn}^{2+}] \times [\text{S}^{2-}]$

b  $K_{sp} = [\text{Ag}^+]^2 \times [\text{CO}_3^{2-}]$

c  $K_{sp} = [\text{V}^{3+}] \times [\text{OH}^-]^3$

■ WORKED EXAMPLE 4.4

1  $5 \times 10^{-9}$

2  $1 \times 10^{-19}$

■ WORKED EXAMPLE 4.5

1  $[\text{Ag}^+] = [\text{Cl}^-] = 1.33 \times 10^{-5} \text{ mol L}^{-1}$

2  $[\text{Ba}^{2+}] = 0.0399 \text{ mol L}^{-1}$

$[\text{OH}^-] = 0.0799 \text{ mol L}^{-1}$

3  $[\text{Cu}^{2+}] = 5.01 \times 10^{-8} \text{ mol L}^{-1}$

$[\text{PO}_4^{3-}] = 3.34 \times 10^{-8} \text{ mol L}^{-1}$



### WORKED EXAMPLE 4.6

- a silver chloride is insoluble
- b silver sulfate is sparingly soluble

### WORKED EXAMPLE 4.7

precipitate formed

### CHECK YOUR UNDERSTANDING 4.7

- 2  $K_{sp} = 5.20 \times 10^{-10}$
- 3 a  $[\text{Fe}^{2+}] = [\text{CO}_3^{2-}] = 5.59 \times 10^{-6} \text{ mol L}^{-1}$   
b  $[\text{Eu}^{3+}] = 1.37 \times 10^{-7} \text{ mol L}^{-1}$   
 $[\text{OH}^-] = 4.10 \times 10^{-7} \text{ mol L}^{-1}$
- 4 a insoluble  
b sparingly soluble
- 5 no precipitate forms

### WORKED EXAMPLE 4.8

- 1 solubility is slightly higher in  $0.375 \text{ mol L}^{-1} \text{ Na}_2\text{CO}_3$
- 2 solubility is approximately  $10^8$  times less soluble in  $0.075 \text{ mol L}^{-1} \text{ NaOH}$  than in water

### CHECK YOUR UNDERSTANDING 4.8

- 2  $0.0118 \text{ mol L}^{-1}$
- 4 It is approximately  $4 \times 10^6$  times less soluble in  $0.20 \text{ mol L}^{-1} \text{ NaOH}$  than in water.
- 5 Thus, less soluble in  $0.30 \text{ mol L}^{-1}$  by a factor of 2.

### CHAPTER REVIEW QUESTIONS

- 6 a Lead chloride is slightly soluble so will form a precipitate.  
 $2\text{NaCl}(\text{aq}) + \text{Pb}(\text{NO}_3)_2(\text{aq}) \rightarrow 2\text{NaNO}_3(\text{aq}) + \text{PbCl}_2(\text{s})$   
b no precipitate formed  
c Barium sulfate  
 $\text{Ba}(\text{OH})_2(\text{aq}) + \text{Na}_2\text{SO}_4(\text{s}) \rightarrow \text{BaSO}_4(\text{s}) + 2\text{NaOH}(\text{aq})$   
d Aluminium sulfite  
 $2\text{AlCl}_3(\text{aq}) + 3(\text{NH}_4)_2\text{SO}_3(\text{aq}) \rightarrow \text{Al}_2(\text{SO}_3)_3(\text{s}) + 6\text{NH}_4\text{Cl}$   
e Copper(II) carbonate  
 $\text{CuBr}_2(\text{aq}) + \text{Na}_2\text{CO}_3(\text{aq}) \rightarrow 2\text{NaBr}_2(\text{aq}) + \text{CuCO}_3(\text{s})$
- 7 a  $\text{Mg}^{2+}(\text{aq}) + 2\text{OH}^-(\text{aq}) \rightarrow \text{Mg}(\text{OH})_2(\text{s})$   
b  $K_{sp} = [\text{Mg}^{2+}] \times [\text{OH}^-]^2$   
c  $K_{sp} = 1.41 \times 10^{-12}$   
d  $s = 7.06 \times 10^{-5} \text{ mol L}^{-1}$

8  $\text{Fe}(\text{OH})_3$  has the greater concentration of iron ions.

- 9 a endothermic  
b  $K_{sp} = [\text{Ag}^+]^2 \times [\text{SO}_4^{2-}]$   
c  $[\text{Ag}_2\text{SO}_4] = 0.0691 \text{ mol L}^{-1}$   
d  $K_{sp} = 0.00132$
- 10  $K_{sp} = 3.20 \times 10^{-7}$
- 11 a  $[\text{Ag}_2\text{SO}_4] = 6.51 \times 10^{-6} \text{ mol L}^{-1}$   
b  $K_{sp} = 8.48 \times 10^{-11}$   
c  $s = 8.48 \times 10^{-10} \text{ mol L}^{-1}$

### END-OF-MODULE 5 REVIEW

1 a  $K = \frac{[\text{NO}_2]^2}{[\text{NO}]^2 \times [\text{O}_2]}$

d  $[\text{NO}] = 0.14 \text{ mol L}^{-1}$

2 a

	$\text{HI}(\text{g})$	$\text{H}_2(\text{g})$	$\text{I}_2(\text{g})$
Initial (mol)	1.00	0	0
Change (mol)	-0.22	+0.11	+0.11
Equilibrium (mol)	0.78	0.11	0.11

b  $K = \frac{[\text{H}_2] \times [\text{I}_2]}{[\text{HI}]^2}$   
 $= \frac{0.11 \times 0.11}{0.78^2} = 0.020$

3 b 0.323

4 200

9 D

10 a  $K = \frac{[\text{NO}_2]^2}{[\text{N}_2\text{O}_4]}$

d 14.6

11 a 0.611 mol

b 1.477 mol

## CHAPTER 5

### CHECK YOUR UNDERSTANDING 5.1

- 1 a Hydrofluoric acid  
b Sulfuric acid  
c Carbonic acid
- 2 a HBr  
b HCN  
c  $\text{HNO}_3$
- 3 a Potassium hydroxide  
b Calcium hydroxide  
c Iron(III) oxide
- 4 a LiOH

b  $\text{Co}(\text{OH})_2$

c MgO

5 a Dihydroxido | oxido | sulfur  
 $(\text{OH})_2$  | O | S

b iii  $\text{H}_2\text{SO}_4$

### CHECK YOUR UNDERSTANDING 5.2

- 1 indicator colour change, feel, taste
- 5 act as both an acid and a base (e.g.  $\text{Al}_2\text{O}_3$ ,  $\text{ZnO}$ )
- 6 a  $\text{HNO}_3(\text{aq}) + \text{H}_2\text{O}(\text{l}) \rightarrow \text{H}_3\text{O}^+(\text{aq}) + \text{NO}_3^-(\text{aq})$   
b  $\text{H}_3\text{PO}_4(\text{aq}) + \text{H}_2\text{O}(\text{l}) \rightarrow 3\text{H}_3\text{O}^+(\text{aq}) + \text{PO}_4^{3-}(\text{aq})$   
c  $\text{Ca}(\text{OH})_2(\text{aq}) \rightarrow \text{Ca}^{2+}(\text{aq}) + 2\text{OH}^-(\text{aq})$   
d  $\text{NH}_4\text{OH}(\text{aq}) \rightarrow \text{NH}_4^+(\text{aq}) + \text{OH}^-(\text{aq})$

### CHECK YOUR UNDERSTANDING 5.3

- 1 a Acid + base  $\rightarrow$  salt + water  
b Acid + carbonate  $\rightarrow$  salt + water + carbon dioxide gas  
c Acid + metal  $\rightarrow$  salt + hydrogen gas
- 2 the reaction of an acid and a base to give salt and water  
For example:  $\text{HCl}(\text{aq}) + \text{NaOH}(\text{aq}) \rightarrow \text{NaCl}(\text{aq}) + \text{H}_2\text{O}(\text{l})$
- 3  $\text{H}^+(\text{aq}) + \text{OH}^-(\text{aq}) \rightarrow \text{H}_2\text{O}(\text{l})$
- 4 a Carbonate ion is  $\text{CO}_3^{2-}$  and the hydrogen carbonate ions is  $\text{HCO}_3^{2-}$ .  
b The reactions produce the same products so are not different.
- 5 a  $\text{HNO}_3(\text{aq}) + \text{KOH}(\text{aq}) \rightarrow \text{KNO}_3(\text{aq}) + \text{H}_2\text{O}(\text{l})$   
b  $\text{H}_2\text{SO}_4(\text{aq}) + \text{ZnO}(\text{aq}) \rightarrow \text{ZnSO}_4(\text{aq}) + \text{H}_2\text{O}(\text{l})$   
c  $2\text{HF}(\text{aq}) + \text{Mg}(\text{OH})_2(\text{s}) \rightarrow \text{MgF}_2(\text{aq}) + 2\text{H}_2\text{O}(\text{l})$   
d  $\text{H}_3\text{PO}_4(\text{aq}) + 3\text{NH}_3(\text{aq}) \rightarrow (\text{NH}_4)_3\text{PO}_4(\text{aq})$   
e  $2\text{CH}_3\text{COOH}(\text{aq}) + \text{Na}_2\text{O}(\text{aq}) \rightarrow 2\text{CH}_3\text{COONa}(\text{aq}) + \text{H}_2\text{O}(\text{l})$   
f  $\text{CaO}(\text{aq}) + 2\text{NH}_4\text{NO}_3(\text{aq}) \rightarrow \text{Ca}(\text{NO}_3)_2(\text{aq}) + 2\text{NH}_3(\text{aq}) + \text{H}_2\text{O}(\text{l})$
- 6 a  $\text{H}_2\text{SO}_4(\text{aq}) + 2\text{NaOH}(\text{aq}) \rightarrow \text{Na}_2\text{SO}_4(\text{aq}) + \text{H}_2\text{O}(\text{l})$   
b  $2\text{CH}_3\text{COOH}(\text{aq}) + \text{Ca}(\text{OH})_2(\text{aq}) \rightarrow \text{Ca}(\text{CH}_3\text{COO})_2(\text{aq}) + 2\text{H}_2\text{O}(\text{l})$   
c  $6\text{HNO}_3(\text{aq}) + 2\text{Fe}(\text{s}) \rightarrow 2\text{Fe}(\text{NO}_3)_3(\text{aq}) + 3\text{H}_2(\text{g})$

- d  $2\text{HCl}(\text{aq}) + \text{Zn}(\text{s}) \rightarrow \text{Zn}(\text{Cl})_2(\text{aq}) + 3\text{H}_2(\text{g})$
- e  $2\text{HF}(\text{aq}) + \text{CaHCO}_3(\text{s}) \rightarrow \text{CaF}_2(\text{aq}) + \text{H}_2\text{O}(\text{l}) + \text{CO}_2(\text{g})$
- f  $2\text{HNO}_3(\text{aq}) + \text{CuCO}_3(\text{s}) \rightarrow \text{Cu}(\text{NO}_3)_2(\text{aq}) + \text{H}_2\text{O}(\text{l}) + \text{CO}_2(\text{g})$

#### ■ CHECK YOUR UNDERSTANDING 5.4

- 1 a  $\text{H}^+(\text{aq}) + \text{OH}^-(\text{aq}) \rightarrow \text{H}_2\text{O}(\text{l})$   
 b Bond between  $\text{H}^+$  and  $\text{O}$  in  $\text{OH}^-$  is being formed.  
 d  $\text{H}^+(\text{aq}) + \text{OH}^-(\text{aq}) \rightarrow \text{H}_2\text{O}(\text{l}) + \text{energy}$
- 4 a  $\text{HCl}(\text{aq}) + \text{KOH}(\text{aq}) \rightarrow \text{KCl}(\text{aq}) + \text{H}_2\text{O}(\text{l})$   
 b 0.585 kJ  
 c 58.5 kJ mol<sup>-1</sup>
- 7  $\text{H}_2\text{SO}_4(\text{aq}) + 2\text{NH}_3(\text{aq}) \rightarrow (\text{NH}_4)_2\text{SO}_4(\text{aq})$
- 8 a Blue flowers indicate acidic soil.

#### ■ CHAPTER REVIEW QUESTIONS

- 2 a Phosphoric acid (acid)  
 b Nitric acid (acid)  
 c Copper(II) oxide (base)  
 d Ammonia (base)
- 3 a  $\text{CH}_3\text{COOH}$   
 b  $\text{H}_2\text{SO}_3$   
 c  $\text{K}_2\text{O}$   
 d  $\text{NH}_4\text{OH}$
- 5 a  $\text{H}_2\text{SO}_4(\text{aq}) + 2\text{H}_2\text{O}(\text{l}) \rightarrow 2\text{H}_3\text{O}^+(\text{aq}) + \text{SO}_4^{2-}(\text{aq})$   
 b  $\text{HF}(\text{aq}) + \text{H}_2\text{O}(\text{l}) \rightarrow \text{H}_3\text{O}^+(\text{aq}) + \text{F}^-(\text{aq})$   
 c  $\text{NaO}(\text{s}) + \text{H}_2\text{O}(\text{l}) \rightarrow \text{Na}^+(\text{aq}) + 2\text{OH}^-(\text{aq})$   
 d  $\text{KOH}(\text{aq}) \rightarrow \text{K}^+(\text{aq}) + \text{OH}^-(\text{aq})$
- 7 a  $2\text{HNO}_3(\text{aq}) + \text{Ba}(\text{OH})_2(\text{aq}) \rightarrow \text{Ba}(\text{NO}_3)_2(\text{aq}) + 2\text{H}_2\text{O}(\text{l})$   
 b  $3\text{HCl}(\text{aq}) + \text{Al}(\text{OH})_3(\text{s}) \rightarrow \text{AlCl}_3(\text{aq}) + 3\text{H}_2\text{O}(\text{l})$   
 c  $\text{H}_2\text{SO}_4(\text{aq}) + \text{Mg}(\text{s}) \rightarrow \text{MgSO}_4(\text{aq}) + \text{H}_2(\text{g})$   
 d  $2\text{CH}_3\text{COOH}(\text{aq}) + \text{MgCO}_3(\text{s}) \rightarrow (\text{CH}_3\text{COO})_2\text{Mg}(\text{aq}) + \text{CO}_2(\text{g}) + \text{H}_2\text{O}(\text{l})$   
 e  $\text{H}_3\text{PO}_4(\text{aq}) + 3\text{NaHCO}_3(\text{s}) \rightarrow \text{Na}_3\text{PO}_4(\text{aq}) + 3\text{CO}_2(\text{g}) + 3\text{H}_2\text{O}(\text{l})$
- 9 42.7 kJ mol<sup>-1</sup>
- 10 58.5 kJ mol<sup>-1</sup>

## CHAPTER 6

#### ■ CHECK YOUR UNDERSTANDING 6.1

- 4 a  $\text{HNO}_3/\text{NO}_3^-; \text{H}_2\text{O}/\text{H}_3\text{O}^+$   
 b  $\text{NH}_4^+/\text{NH}_3/\text{H}_2\text{O}/\text{H}_3\text{O}^+$   
 c  $\text{HSO}_4^-/\text{SO}_4^{2-}; \text{O}_2^-/\text{OH}^-$   
 d  $\text{H}_2\text{PO}_4^-/\text{HPO}_4^{2-}; \text{CO}_3^{2-}/\text{HCO}_3^-$   
 e  $\text{HC}_2\text{H}_3\text{O}_2/\text{C}_2\text{H}_3\text{O}_2^-/\text{HS}^-/\text{H}_2\text{S}$
- 6 a  $\text{H}_2\text{CO}_3$   
 b  $\text{H}_2\text{O}$   
 c  $\text{H}_2\text{PO}_4^-$
- 7 a  $\text{HCO}_3^-$   
 b  $\text{OCN}^-$   
 c  $\text{PO}_4^{3-}$

#### ■ WORKED EXAMPLE 6.1

- 1 pH = 3  
 2 pH = 4.92  
 3 0.000001 mol L<sup>-1</sup>  
 4  $2.00 \times 10^{-12}$  mol L<sup>-1</sup>

#### ■ CHECK YOUR UNDERSTANDING 6.2

- 5 b When pH = 7 then  $[\text{H}^+] = [\text{OH}^-]$
- 6 a pH 1–3  
 b pH 7  
 c pH 8–10  
 d pH 11–13
- 8 a pH = 2  
 b pH = 1.76
- 9 a 0.001 mol L<sup>-1</sup>  
 b  $3.98 \times 10^{-11}$  mol L<sup>-1</sup>

#### ■ CHECK YOUR UNDERSTANDING 6.3

- 1 Nitric acid –  $\text{HNO}_3(\text{aq})$   
 Sulfuric acid –  $\text{H}_2\text{SO}_4(\text{aq})$   
 Sodium hydroxide –  $\text{NaOH}(\text{aq})$
- 2 a  $\text{HNO}_3(\text{aq}) + \text{H}_2\text{O}(\text{l}) \rightarrow \text{H}_3\text{O}^+(\text{aq}) + \text{NO}_3^-(\text{aq})$   
 b  $\text{H}_2\text{SO}_4(\text{aq}) + \text{H}_2\text{O}(\text{l}) \rightarrow \text{H}_3\text{O}^+(\text{aq}) + \text{HSO}_4^-(\text{aq})$   
 $\text{HSO}_4^-(\text{aq}) + \text{H}_2\text{O}(\text{l}) \rightleftharpoons \text{H}_3\text{O}^+(\text{aq}) + \text{SO}_4^{2-}(\text{aq})$   
 c  $\text{HF}(\text{aq}) + \text{H}_2\text{O}(\text{l}) \rightleftharpoons \text{H}_3\text{O}^+(\text{aq}) + \text{F}^-(\text{aq})$   
 d  $\text{H}_3\text{PO}_4(\text{aq}) + \text{H}_2\text{O}(\text{l}) \rightarrow \text{H}_3\text{O}^+(\text{aq}) + \text{H}_2\text{PO}_4^-(\text{aq})$   
 $\text{H}_2\text{PO}_4^-(\text{aq}) + \text{H}_2\text{O}(\text{l}) \rightleftharpoons \text{H}_3\text{O}^+(\text{aq}) + \text{HPO}_4^{2-}(\text{aq})$   
 $\text{HPO}_4^{2-}(\text{aq}) + \text{H}_2\text{O}(\text{l}) \rightleftharpoons \text{H}_3\text{O}^+(\text{aq}) + \text{PO}_4^{3-}(\text{aq})$

- 3 a  $\text{Ba}(\text{OH})_2(\text{aq}) \rightarrow \text{Ba}_2^+(\text{aq}) + 2\text{OH}^-(\text{aq})$   
 b  $\text{CaO}(\text{aq}) + \text{H}_2\text{O}(\text{l}) \rightarrow \text{Ca}^{2+}(\text{aq}) + 2\text{OH}^-(\text{aq})$   
 c  $\text{NH}_4\text{OH}(\text{aq}) \rightleftharpoons \text{NH}_4^+(\text{aq}) + \text{OH}^-(\text{aq})$

#### ■ WORKED EXAMPLE 6.2

- 1 pH = 12.6  
 2  $[\text{OH}^-] = [\text{NaOH}] = 3.16 \times 10^{-5}$  mol L<sup>-1</sup>  
 3  $[\text{HCl}] = 2.1 \times 10^{-7}$  mol L<sup>-1</sup>

#### ■ CHECK YOUR UNDERSTANDING 6.4

- 1  $2\text{H}_2\text{O}(\text{l}) \rightleftharpoons \text{H}_3\text{O}^+(\text{aq}) + \text{OH}^-(\text{aq})$
- 2 a  $K_w = [\text{H}^+][\text{OH}^-] = 1 \times 10^{-14}$
- 3 a  $[\text{H}_3\text{O}^+] = 10^{-5}$  mol L<sup>-1</sup>,  $[\text{OH}^-] = 10^{-9}$  mol L<sup>-1</sup>  
 b  $[\text{H}_3\text{O}^+] = 10^{-13} = 0.1$  mol L<sup>-1</sup>,  $[\text{OH}^-] = 10^{-1}$  mol L<sup>-1</sup>  
 c  $[\text{H}_3\text{O}^+] = 10^{-3}$  mol L<sup>-1</sup>,  $[\text{OH}^-] = 10^{-11}$  mol L<sup>-1</sup>
- 4 a pH = 2  
 b pH = 13  
 c pH = 0  
 d pH = 0.64  
 e pH = 12
- 5 a 0.0032 mol L<sup>-1</sup>  
 b 0.001 mol L<sup>-1</sup>  
 c 0.00005 mol L<sup>-1</sup>

#### ■ WORKED EXAMPLE 6.3

- 1  $\text{pOH} = -\log[\text{OH}^-] = 3$   
 2  $\text{pOH} = -\log[\text{OH}^-] = 2.1$   
 3  $[\text{OH}^-] = 10^{-8}$  mol L<sup>-1</sup>  
 4  $[\text{OH}^-] = 6.76 \times 10^{-2}$  mol L<sup>-1</sup>  
 5  $6.31 \times 10^{-12}$  mol L<sup>-1</sup>

#### ■ WORKED EXAMPLE 6.4

- 1 11.6  
 2 12.4  
 3  $1.58 \times 10^{-4}$  mol L<sup>-1</sup>

#### ■ WORKED EXAMPLE 6.5

- 1 pH = 4  
 2 pOH = 13.5  
 3 pH = 2.5

#### ■ CHECK YOUR UNDERSTANDING 6.5

- 1 a  $\text{pOH} = -\log[\text{OH}^-]$   
 b  $\text{pH} + \text{pOH} = 14$
- 2 a  $\text{pOH} = 1.03$   
 b  $[\text{OH}^-] = 6.17 \times 10^{-4}$  mol L<sup>-1</sup>

- 3 a  $[\text{OH}^-] = 1 \text{ mol L}^{-1}$ ;  $[\text{H}_3\text{O}^+] = 0^{-14}$   
 b  $[\text{OH}^-] = 10^{-11} \text{ mol L}^{-1}$ ;  $[\text{H}_3\text{O}^+] = 10^{-3}$   
 c  $[\text{H}_3\text{O}^+] = 10^{-8} \text{ mol L}^{-1}$ ;  $[\text{OH}^-] = 10^{-6} \text{ mol L}^{-1}$

- 4 a pH = -0.10  
 b pH = 12.7

- 5 a pOH = 12.2  
 b pOH = 1.2

- 6 a  $0.001 \text{ mol L}^{-1}$   
 b  $5 \times 10^{-5} \text{ mol L}^{-1}$

- 8 a pH = 10  
 b pH = 6  
 c 3.7

#### WORKED EXAMPLE 6.6

- 1  $K_a = 7.26 \times 10^{-4}$   
 2 pH = 2.73

#### WORKED EXAMPLE 6.7

- 1 1.35%  
 2 0.607%

#### CHECK YOUR UNDERSTANDING 6.6

1 a  $K_a = \frac{[\text{H}_3\text{O}^+][\text{OBr}^-]}{[\text{HOBr}]}$

b  $K_a = \frac{[\text{H}_3\text{O}^+][\text{CN}^-]}{[\text{HCN}]}$

c  $K_a = \frac{[\text{H}_3\text{O}^+][\text{NH}_3]}{[\text{NH}_4^+]}$

- 3 a  $\text{p}K_a = -\log_{10} K_a$   
 5 (strongest)  $X > Z > W > Y$  (weakest)  
 7 a pH = 6.22  
 b 0.0173%  
 8 a  $\text{CH}_3\text{COOH}(\text{l}) + \text{H}_2\text{O}(\text{l}) \rightleftharpoons \text{CH}_3\text{COO}^-(\text{aq}) + \text{H}_3\text{O}^+(\text{aq})$   
 b pH = 2.58  
 9 a i  $K_a = 5.01 \times 10^{-10}$   
 $\text{p}K_a = 9.3$   
 ii  $K_a = 8.9 \times 10^{-8}$   
 $\text{p}K_a = 7.1$   
 b HS is the strongest acid.  
 10  $1.1 \times 10^{-3} \text{ mol L}^{-1}$

#### WORKED EXAMPLE 6.8

- 1  $1.32 \times 10^{-10}$   
 2 pH = 12.1

#### CHECK YOUR UNDERSTANDING 6.7

2 a  $K_b = \frac{[\text{HCN}][\text{OH}^-]}{[\text{CN}^-]}$

b  $K_b = \frac{[\text{H}_2\text{S}][\text{OH}^-]}{[\text{HS}^-]}$

- 4 (Weakest)  $P > R > Q > S$  (strongest)  
 6  $1.13 \times 10^{-10}$   
 7 pH = 10.8

#### WORKED EXAMPLE 6.9

- 1 pH = 1.5  
 2 8.6 g  
 3 277 mL

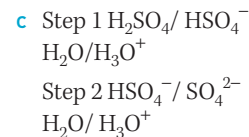
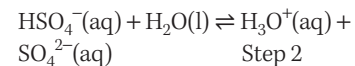
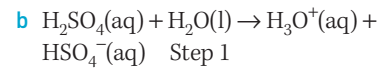
#### CHECK YOUR UNDERSTANDING 6.8

- 1 When  $[\text{H}^+] = [\text{OH}^-]$  and pH = 7.  
 2 a pH = 12.6  
 b pH = 2.5  
 c pH = 11.5  
 4 a/b  
 i  $\text{H}_2\text{CO}_3(\text{aq}) + 2\text{KOH}(\text{aq}) \rightarrow \text{K}_2\text{CO}_3(\text{aq}) + 2\text{H}_2\text{O}(\text{l})$ ; pH > 7.  
 ii  $\text{HNO}_3(\text{aq}) + \text{NH}_3(\text{aq}) \rightarrow \text{NH}_4\text{NO}_3(\text{aq}) + \text{H}_2\text{O}(\text{l})$ ; pH < 7.  
 iii  $\text{H}_2\text{SO}_4(\text{aq}) + 2\text{NaOH}(\text{aq}) \rightarrow \text{Na}_2\text{SO}_4(\text{aq}) + 2\text{H}_2\text{O}(\text{l})$ ; pH = 7  
 5 a  $\text{HS}^-(\text{aq}) + \text{H}_2\text{O}(\text{l}) \rightarrow \text{S}^-(\text{aq}) + \text{H}_3\text{O}^+(\text{aq})$   
 b  $\text{HS}^-(\text{aq}) + \text{HCl}(\text{aq}) \rightarrow \text{H}_2\text{S}(\text{aq}) + \text{Cl}^-(\text{aq})$   
 c  $\text{HS}^-(\text{aq}) + \text{NaOH}(\text{aq}) \rightarrow \text{NaS}(\text{aq}) + \text{H}_2\text{O}(\text{l})$   
 6 a pH would be lower.  
 b 16.6 g of NaOH

#### CHAPTER REVIEW

- 3 a purple  
 b red  
 c no colour change  
 4 B  
 5 C  
 6 a i  $\text{HNO}_3(\text{aq}) + \text{H}_2\text{O}(\text{l}) \rightarrow \text{H}_3\text{O}^+(\text{aq}) + \text{NO}_3^-(\text{aq})$   
 ii  $\text{CH}_3\text{COOH}(\text{aq}) + \text{H}_2\text{O}(\text{l}) \rightleftharpoons \text{H}_3\text{O}^+(\text{aq}) + \text{CH}_3\text{COO}^-(\text{aq})$   
 b i  $\text{Na}_2\text{O}(\text{aq}) + \text{H}_2\text{O}(\text{l}) \rightarrow 2\text{Na}^+(\text{aq}) + 2\text{OH}^-(\text{aq})$   
 ii  $\text{NH}_3(\text{aq}) + \text{H}_2\text{O}(\text{l}) \rightleftharpoons \text{NH}_4^+(\text{aq}) + \text{OH}^-(\text{aq})$

- 7 a Sulfuric acid ( $\text{H}_2\text{SO}_4$ ); phosphoric acid ( $\text{H}_3\text{PO}_4$ )



- 8 a pH = 1.30  
 pOH = 12.7  
 b pOH = 1.70  
 pH = 12.3  
 c pH = 1.0                      pOH = 13

- 9 a pH = 1.62  
 b pH = 2.7  
 c pH = 11.7

10 0.0096

11  $1.0 \times 10^{-5}$

12 3 g

- 14 a Let citric acid be represented as HC:

$$K_a = \frac{[\text{C}^-][\text{H}^+]}{[\text{HC}]}$$

- 15 a  $1.6 \times 10^{-4}$   
 b  $2.5 \times 10^{-8} \text{ mol L}^{-1}$   
 16 a basic  
 b basic  
 c acidic

- 17 a  $K_a = \frac{[\text{OH}^-][\text{H}_3\text{BO}_3]}{[\text{B}(\text{OH})_4^-]}$   
 b  $[\text{H}^+] = 7.76 \times 10^{-12} \text{ mol L}^{-1}$   
 $[\text{OH}^-] = 0.0013 \text{ mol L}^{-1}$   
 c  $[\text{OH}^-] = 0.0013 \text{ mol L}^{-1}$   
 d  $1.7 \times 10^{-5}$   
 e 4.8

18 a  $K_a = \frac{[\text{CN}^-][\text{H}_3\text{O}^+]}{[\text{HCN}]}$

- b pH = 6.6  
 c 0.25%  
 19 a  $\text{H}_2\text{S}(\text{aq}) + \text{NH}_3(\text{aq}) \rightleftharpoons \text{HS}^-(\text{aq}) + \text{NH}_4^+(\text{aq})$   
 $\text{HS}^-(\text{aq}) + \text{H}_2\text{O}(\text{l}) \rightleftharpoons \text{H}_2\text{S}(\text{aq}) + \text{OH}^-(\text{aq})$   
 $\text{NH}_4^+(\text{aq}) + \text{H}_2\text{O}(\text{l}) \rightleftharpoons \text{NH}_3(\text{aq}) + \text{H}_3\text{O}^+(\text{aq})$   
 b  $1 \times 10^{-7}$   
 c basic

- 20 a pH = 11.0  
b pH = 154

## CHAPTER 7

### ■ CHECK YOUR UNDERSTANDING 7.2

- 5 a  $0.135 \times 0.250 = 0.03375 \text{ mol}$   
 $84.01 \times 0.03375 = .84 \text{ g}$

### ■ WORKED EXAMPLES 7.1/7.2

- 1  $0.254 \text{ mol L}^{-1}$   
2  $C_{\text{HCl}} = 0.187 \text{ mol L}^{-1}$   
 $C_{\text{Ba(OH)}_2} = 0.101 \text{ mol L}^{-1}$   
 $[\text{Ba(OH)}_2] = 17.3 \text{ g L}^{-1}$

### ■ CHECK YOUR UNDERSTANDING 7.3

- 1 titrant.  
4 a Bromothymol blue  
b  $0.0584 \text{ mol L}^{-1}$   
5 a Methyl orange  
d  $\text{H}_2\text{SO}_4(\text{aq}) + 2\text{NaHCO}_3(\text{aq}) \rightarrow$   
 $\text{Na}_2\text{SO}_4(\text{aq}) + \text{CO}_2(\text{g}) + \text{H}_2\text{O}(\text{l})$   
e  $0.0811 \text{ mol L}^{-1}$

### ■ WORKED EXAMPLE 7.3

- 1 0.202 g  
36.6%  
2 0.125 g  
33.4%

### ■ CHECK YOUR UNDERSTANDING 7.4

- 2 a A change in conductivity values  
8 b 12.5 mL  
c  $0.2 \text{ mol L}^{-1}$   
9 83.1%  
10 a a diprotic acid  
b 10 mL

### ■ CHECK YOUR UNDERSTANDING 7.5

- 4 a 25%

### ■ CHAPTER REVIEW QUESTIONS

- 10 a Equivalence point  
11 a  $\text{Ba(OH)}_2(\text{aq}) + 2\text{HCl}(\text{aq}) \rightarrow$   
 $\text{BaCl}_2(\text{aq}) + \text{H}_2\text{O}(\text{l})$   
b Bromothymol blue  
c blue to yellow.  
d  $0.427 \text{ mol L}^{-1}$   
12 a Hydrogen peroxide  
c  $0.490 \text{ mol L}^{-1}$   
13 a weak acid

b Acetic acid

c pH 8.5.

14 b  $V_{\text{HCl}} = 50 \text{ mL}$

c  $0.125 \text{ mol L}^{-1}$

15 26.75%

16 a  $\text{H}_2\text{PO}_4^-(\text{aq}) + \text{H}_2\text{O}(\text{l}) \rightleftharpoons \text{HPO}_4^{2-}(\text{aq})$   
 $+ \text{H}_3\text{O}^+(\text{aq})$

b  $\text{H}_2\text{PO}_4^-$  is the acid and  $\text{HPO}_4^{2-}$  is its conjugate base.

### ■ END-OF-MODULE 6 REVIEW

- 1 C  
2 A  
3 B  
4 B  
5 C  
6 D  
7 C  
8 B  
9 B  
10 C  
11 B  
14 a  $54.9 \text{ kJ mol}^{-1}$   $\text{H}_2\text{O}$  produced  
c  $14.5 \text{ mol L}^{-1}$   
15 c  $\text{CO}_3^-$   
16 a  $0.091 \text{ mol L}^{-1}$   
b  $0.91 \text{ mol L}^{-1}$   
17 a  $\text{B} + \text{H}_2\text{O} \rightleftharpoons \text{BH}^+ + \text{OH}^-$   
b  $K_b = \frac{[\text{BH}^+][\text{OH}^-]}{[\text{B}]}$   
c  $K_a = 2.3 \times 10^{-11}$   
d pH = 11.2

## CHAPTER 8

### ■ WORKED EXAMPLE 8.1

- 1 2,2-dimethylpropane  
2 2,3,4,4-tetramethylhexane

### ■ CHECK YOUR UNDERSTANDING 8.2

- 1  $\text{C}_n\text{H}_{2n+2}$   
2 1 meth-, 2 eth-, 3 prop-, 4 but-, 5 pent-,  
6 hex-, 7 hept-, 8 oct-, 9 non-, 10 dec-  
4 a 3-methylpentane  
b 3-methylpentane  
c 2,2-dimethylbutane  
d 3-methylpentane  
e 3,3,4,4-tetramethylhexane

### ■ WORKED EXAMPLE 8.2

- 1 2,3-dimethyl-1-butene  
2 4-methyl-2-hexene

### ■ CHECK YOUR UNDERSTANDING 8.3

- 1  $\text{C}_n\text{H}_{2n}$   
3 a 3-methyl-1-butene  
b 2,4-dimethyl-2-pentene  
c 2,4,4-trimethyl-2-pentene  
d 2,3-dimethyl-1-butene

### ■ CHECK YOUR UNDERSTANDING 8.4

- 1  $\text{C}_n\text{H}_{2n-2}$   
2 a 4-methyl-2-hexyne  
b 4-methyl-2-pentyne  
c 3,3-dimethyl-1-pentyne  
d 4-methyl-2-pentyne  
e 3,3-dimethyl-1-pentyne

### ■ WORKED EXAMPLE 8.3

- 1 1-bromo-1,2-dichloro-2-fluoropropane  
2 3,4,4,5-tetrachloro-3-methyl-1-pentyne

### ■ CHECK YOUR UNDERSTANDING 8.5

- 1 a 1,2-dichloro-1-butene  
b 2,2,3,3-tetrachloro-1-fluorobutane  
c 3,4-dichloro-3,4-difluoro-1-pentyne  
d 3-bromo-1,1,2-trichloro-1-butene  
e 1,4,4-trichloro-2-methyl-1-pentene  
f 1-bromo-2,2-dimethylbutane  
g 4-bromo-2,4-dichloro-3-ethyl-2,3-dimethylhexane

### ■ CHECK YOUR UNDERSTANDING 8.6/8.7

- 4 Aromatic compounds contain the benzene molecule as part of its structure.  
5 Parent compound is benzene –  $\text{C}_6\text{H}_6$

### ■ CHAPTER REVIEW QUESTIONS

- 3 a Tetrahedral  
b Planar  
c Linear  
d Linear

6

	ALKANE	ALKENE	ALKYNE
<b>General formula</b>	$\text{C}_n\text{H}_{2n+2}$	$\text{C}_n\text{H}_{2n}$	$\text{C}_n\text{H}_{2n-2}$

- 7 a 2-methylbutane

- b 4-ethyl-2,3,3-dimethylhexane  
 c 2-pentene  
 d 2,4,4-trimethyl-2-pentene  
 e 3,5-dimethyl-1-hexyne  
 f 4-methyl-2-hexyne  
 g 1,2-dichloro-3,3-difluoropentane  
 h 1,1,4-trichloro-1,2,4-trifluoro-2-heptane
- 10 a No – same exact molecule (both 2-methylbutane).  
 b Yes (2-methylpentane and 3-methylpentane).  
 c No – same exact molecule (both 3-methylpentane).  
 d Yes (2,3-dimethylpentane and 2,4-dimethylpentane).
- 13 a Chain isomers
- 14 a

ALKENE	MOLECULAR WEIGHT
Ethene	28.052
Propene	42.078
1-butene	56.104
1-pentene	70.130
1-hexene	84.156
1-heptene	98.182
1-octene	112.208

- 15 a Compound Z, Compound X, Compound Y  
 16 No.

## CHAPTER 9

### WORKED EXAMPLE 9.1

- 1 3-methyl-3-pentanol  
 2 3-methyl-2-butanol

### WORKED EXAMPLE 9.2

- 1 Chain isomer – 2-butanol  
 Position isomer – 2-methyl-1-butanol  
 2 2-methyl-2-pentanol  
 3-methyl-2-pentanol

### CHECK YOUR UNDERSTANDING 9.1/9.2a

- 3 Hydroxyl group —OH  
 4 General formula:  $C_nH_{2n+1}OH$   
 3 carbons:  $C_3H_7OH$   
 6 carbons:  $C_6H_{13}OH$   
 8 carbons:  $C_8H_{17}OH$

- 5 a 2-butanol  
 b 2,3-dimethyl-1-butanol  
 c 2,2-dimethyl-1-butanol  
 d 3-ethyl-2,3-dimethyl-2-hexanol
- 7 b 1-hexanol  
 c 2-methyl-2-pentanol
- 9 Question 5: a secondary; b primary; c primary; d tertiary  
 Question 6: a secondary; b primary; c tertiary; d secondary

### WORKED EXAMPLE 9.3

- 1 2-methylpropanal  
 2 3,3,4-trimethyl-2-pentanone

### CHECK YOUR UNDERSTANDING 9.3

- 3 a 2-methylbutanal  
 b 4-ethyl-2,5-dimethylhexanal  
 c 3-ethyl-4-methyl-2-pentanone  
 d 3-methyl-2-butanone
- 6 a 1-propanol  $60.094 \text{ g mol}^{-1}$ , butane  $58.12 \text{ g mol}^{-1}$ , propanal  $58.078 \text{ g mol}^{-1}$   
 b Butane  $\rightarrow$  propanal  $\rightarrow$  1-propanol

### CHECK YOUR UNDERSTANDING 9.4

- 2 b One carbon – methanoic acid (IUPAC)/formaldehyde (common)  
 Two carbons – ethanoic acid (IUPAC)/acetic acid (common)  
 Three carbons – propanoic acid (IUPAC)/propionic acid (common)
- 3 a 2,3-dimethylpentanoic acid  
 b 2-methylpropanoic acid  
 c 3-ethyl-4,4-dimethylhexanoic acid

### WORKED EXAMPLE 9.4

- 1 Methylpropanamine  
 2 2,3-dimethyl-2-butanamine

### CHECK YOUR UNDERSTANDING 9.5

- 3 a 1-propanamine (primary)  
 b Triethanamine (tertiary)  
 c 3-methyl-2-butanamine (secondary)  
 d Ethanamide (primary)  
 e N-methylethanamide (secondary)  
 f N-propylpropanamide (secondary)

### CHAPTER REVIEW QUESTIONS

- 1 a Hydroxyl  
 b Carboxyl

- c Amine  
 d Ester  
 e Carbonyl  
 f Carbonyl  
 g Amide
- 5 a Alcohol: 2-butanol  
 b Amide: N-methylethanamide  
 c Carboxylic acid: propanoic acid  
 d Amine: propanamine  
 e Ketone: 5-ethyl-3-heptanone  
 f Alcohol: 3-methyl-3-pentanol

## CHAPTER 10

### CHECK YOUR UNDERSTANDING 10.1

- 7 a Inhalation of vapours. Skin contact. Chemicals igniting near a heat source.

### CHECK YOUR UNDERSTANDING 10.2

- 1 a  $C_5H_8(l) + 7O_2(g) \rightarrow 5CO_2(g) + 4H_2O(l)$

### CHECK YOUR UNDERSTANDING 10.3

- 4 a  $C_5H_{12}(l) + \frac{13}{2} O_2(g) \rightarrow 5CO_2(g) + 6H_2O(l)$   
 5 Complete:  $C_4H_{10}(g) + \frac{13}{2} O_2(g) \rightarrow 4CO_2(g) + 5H_2O(l)$   
 Incomplete:  $C_4H_{10}(g) + \frac{9}{2} O_2(g) \rightarrow 4CO(g) + 5H_2O(l)$  OR  
 Incomplete:  $C_4H_{10}(g) + \frac{5}{2} O_2(g) \rightarrow 4C(g) + 5H_2O(l)$

### CHECK YOUR UNDERSTANDING 10.4

- 1 Automobile fuels, plastic packaging, clothes fibres

### CHAPTER REVIEW QUESTIONS

- 8 a Hydration  
 b Combustion  
 c Halogenation  
 d Substitution
- 11 a  $C_7H_{14}(l) + \frac{21}{2} O_2(g) \rightarrow 7CO_2(g) + 7H_2O(l)$   
 b  $C_3H_4(l) + 4O_2(g) \rightarrow 3CO_2(g) + 2H_2O(l)$   
 c  $C_5H_{14}(l) + \frac{17}{2} O_2(g) \rightarrow 5CO_2(g) + 7H_2O(l)$



- 12  $C_4H_{10}(l) + \frac{9}{2} O_2(g) \rightarrow 4CO(g) + 5H_2O(l)$   
 $C_4H_{10}(l) + \frac{5}{2} O_2(g) \rightarrow 4C(g) + 5H_2O(l)$
- 25 b Combustion of ethanol:  $C_2H_5OH(l) + \frac{7}{2} O_2(g) \rightarrow 2CO_2(g) + 3H_2O(l)$   
 Combustion of pentane:  $C_5H_{12}(l) + 8O_2(g) \rightarrow 5CO_2(g) + 6H_2O(l)$   
 Combustion of 1-hexene:  $C_6H_{12}(l) + 9O_2(g) \rightarrow 6CO_2(g) + 6H_2O(l)$

## CHAPTER 11

### WORKED EXAMPLE 11.1

- 1  $-2.07 \times 10^3 \text{ kJ mol}^{-1}$   
 2  $34.0^\circ\text{C}$

### WORKED EXAMPLE 11.2

- 1  $36.02 \text{ kJ g}^{-1}$   
 2  $2.9 \times 10^3 \text{ kJ L}^{-1}$

### CHECK YOUR UNDERSTANDING 11.1

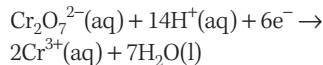
- 2 a  $C_5H_{11}OH(l) + \frac{15}{2} O_2(g) \rightarrow 5CO_2(g) + 6H_2O(l)$   
 b  $C_4H_9OH(l) + 6O_2(g) \rightarrow 4CO_2(g) + 5H_2O(l)$
- 5  $-451 \text{ kJ mol}^{-1}$   
 6 a  $-2.3 \times 10^3 \text{ kJ mol}^{-1}$   
 b  $304 \text{ kJ g}^{-1}$   
 7 a  $15.8^\circ\text{C}$

### CHECK YOUR UNDERSTANDING 11.2/11.3/11.4

- 5  $MnO_4^-(aq) + 8H^+(aq) + 5e^- \rightarrow Mn^{2+}(aq) + 4H_2O(l)$   
 Colour change from purple to colourless  
 $Cr_2O_7^{2-}(aq) + 14H^+(aq) + 6e^- \rightarrow 2Cr^{3+}(aq) + 7H_2O(l)$   
 Colour change from orange to green
- 7 a  $2MnO_4^-(aq) + 6H^+(aq) + 5C_3H_6O(l) \rightarrow 2Mn^{2+}(aq) + 3H_2O(l) + 5C_3H_6O_2(l)$   
 b  $Cr_2O_7^{2-}(aq) + 8H^+(aq) + 2C_5H_{12}O(l) \rightarrow 2Cr^{3+}(aq) + 7H_2O(l) + 2C_5H_9O(l)$

### CHAPTER REVIEW QUESTIONS

- 1 b Bioethanol and biodiesel  
 6  $MnO_4^-(aq) + 8H^+(aq) + 5e^- \rightarrow Mn^{2+}(aq) + 4H_2O(l)$   
 Colour change from purple to colourless



Colour change from orange to green

### 9 d Transesterification

- 10 a i  $141 \text{ kJ g}^{-1}$   
 ii  $29.52 \text{ kJ g}^{-1}$   
 iii  $47.8 \text{ kJ g}^{-1}$   
 iv  $16.5 \text{ kJ g}^{-1}$
- c i Hydrogen  $\rightarrow$  ethanol  $\rightarrow$  octane  $\rightarrow$  sucrose  
 ii Sucrose  $\rightarrow$  ethanol  $\rightarrow$  octane  $\rightarrow$  hydrogen

11  $-2.82 \times 10^3 \text{ kJ mol}^{-1}$

12  $8.48 \text{ g}$

13 a  $33461 \text{ kJ}$

b  $14 \text{ L}$

c  $\$2.03$

## CHAPTER 12

### CHECK YOUR UNDERSTANDING 12.1/12.2

- 2 a Propyl ethanoate  
 b Butyl methanoate  
 c Propyl pentanoate

### CHECK YOUR UNDERSTANDING 12.3

- 3 a  $CH_3CH_2CH_2NH_2(aq) + HCl(aq) \rightleftharpoons CH_3CH_2CH_2NH_3^+(aq) + Cl^-(aq)$   
 b  $2HCOOH(aq) + Na_2CO_3(aq) \rightleftharpoons 2HCOO^-(aq) + 2Na^+(aq) + H_2O(l) + CO_2(g)$   
 c  $2CH_3COOH(aq) + Ca(s) \rightleftharpoons 2CH_3COO^-(aq) + Ca^{2+}(aq) + H_2(g)$

### CHECK YOUR UNDERSTANDING 12.4

- 5 b  $2RCOO^-(aq) + Ca^{2+}(aq) \rightarrow Ca(RCOO)_2(s)$

### CHAPTER REVIEW QUESTIONS

- 1 a Ethyl propanoate  
 b Propyl propanoate  
 c Methyl butanoate
- 3 The two esters are chain isomers; the ester/carboxylic acid is a functional group isomerism.
- 10 c  $2CH_3CH_2CH_2COOH(aq) + 2Li(s) \rightleftharpoons 2CH_3CH_2CH_2COO^-(aq) + 2Li^+(aq) + H_2(g)$   
 d  $HCOOH(aq) + NaOH(aq) \rightleftharpoons HCOO^-(aq) + Na^+(aq) + H_2O(l)$

- e  $2CH_3CH_2(CH_3)CH_2CH_2COOH(aq) + Na_2CO_3(aq) \rightleftharpoons 2CH_3CH_2(CH_3)CH_2CH_2COO^-(aq) + 2Na^+(aq) + H_2O(l) + CO_2(g)$   
 f  $CH_3CH_2CH_2NH_2(aq) + HCl(aq) \rightleftharpoons CH_3CH_2CH_2NH_3^+(aq) + Cl^-(aq)$

## CHAPTER 13

### CHECK YOUR UNDERSTANDING 13.1

- 5 a  $C_{14}H_{30}(s) \rightarrow C_8H_{18}(l) + C_6H_{12}(l)$   
 b  $C_6H_{12}(l) \rightarrow 2C_3H_6(g)$

### CHECK YOUR UNDERSTANDING 13.2

- 1 a carbon-carbon double bond  
 2 Monomer: ethane; polymer: polyethene

### CHECK YOUR UNDERSTANDING 13.3

- 6 a Biodegradable, transparent, rigid, recyclable  
 b High melting point, flexible, transparent, non-toxic  
 c Transparent, rigid, high melting point, water resistant  
 d Water resistant, flexible, tough, chemical resistant  
 e Flexible, water resistant, tough, strong

### CHECK YOUR UNDERSTANDING 13.4

- 1 Polyesters and polyamides  
 6 a Polymer 1: polyester  
 Polymer 2: polyamide  
 b (see question 5)  
 c Polymer 1: ester  
 Polymer 2: amide  
 7 a i Polyamide  
 ii Polyester  
 c Polymer 1: amine and carboxylic acid  
 Polymer 2: alcohol and carboxylic acid  
 d Polymer 1: 1,5-pentandiamine and heptandioic acid  
 Polymer 2: 1,1-ethandiol and ethandioic acid

### CHAPTER REVIEW QUESTIONS

- 4 A  
 5 A  
 6 C

- 7 A  
8 B  
11 b HDPE  
c i HDPE  
ii LDPE  
12 D  
13 D  
14 a Dispersion forces  
b Dipole–dipole forces (C—Cl) and dispersion forces (hydrocarbon chain)  
c Hydrogen bonds (N—H), dipole–dipole forces (C=O) and dispersion forces (hydrocarbon chain)  
d Dipole–dipole forces (C=O) and dispersion forces (hydrocarbon chain)  
15 a ii Addition  
b ii Condensation  
c ii Condensation  
d ii Condensation  
e ii Condensation  
f ii Addition  
g ii Addition

#### ■ END-OF-MODULE 7 REVIEW

- 2 d  $\text{C}_2\text{H}_5\text{OH}(\text{l}) + 3\text{O}_2(\text{g}) \rightarrow 2\text{CO}_2(\text{g}) + 3\text{H}_2\text{O}(\text{l})$   
i  $\text{C}_6\text{H}_{12}\text{O}_6(\text{aq}) \rightarrow 2\text{C}_2\text{H}_5\text{OH}(\text{aq}) + 2\text{CO}_2(\text{g})$   
j  $2\text{CH}_3\text{COOH}(\text{aq}) + \text{Na}_2\text{CO}_3(\text{aq}) \rightarrow 2\text{CH}_3\text{COO}^-(\text{aq}) + 2\text{Na}^+(\text{aq}) + \text{CO}_2(\text{g}) + \text{H}_2\text{O}(\text{l})$   
5 a Alcohol: 1-pentanol; carboxylic acid: butanoic acid  
Other chemicals: concentrated sulfuric acid catalyst  
b See Figure 12.7, page 345.  
7 a Methanol:  $-239 \text{ kJ mol}^{-1}$   
1-propanol:  $-629 \text{ kJ mol}^{-1}$   
2-propanol:  $-573 \text{ kJ mol}^{-1}$   
b  $\text{kJ g}^{-1}$  (kilojoules per gram)

### CHAPTER 14

#### ■ CHECK YOUR UNDERSTANDING 14.2

- 3 a Soluble  
b Insoluble  
c Soluble

- d Insoluble  
e Soluble  
4 a  $\text{NaCl}(\text{aq}) + \text{AgNO}_3(\text{aq}) \rightarrow \text{NaNO}_3(\text{aq}) + \text{AgCl}(\text{s})$   
b  $\text{CuSO}_4(\text{aq}) + 2\text{KOH}(\text{aq}) \rightarrow \text{Cu}(\text{OH})_2(\text{s}) + \text{K}_2\text{SO}_4(\text{aq})$   
c  $\text{NiCl}_2(\text{aq}) + \text{K}_2\text{SO}_4(\text{aq}) \rightarrow 2\text{KCl}(\text{aq}) + \text{NiSO}_4(\text{s})$   
d  $\text{Na}_2\text{CO}_3(\text{aq}) + \text{FeSO}_4(\text{aq}) \rightarrow \text{FeCO}_3(\text{s}) + \text{Na}_2\text{SO}_4(\text{aq})$   
e  $\text{Zn}(\text{NO}_3)_2(\text{aq}) + (\text{NH}_4)_2\text{S}(\text{aq}) \rightarrow 2\text{NH}_4\text{NO}_3(\text{aq}) + \text{ZnS}(\text{s})$   
f  $\text{K}_2\text{CO}_3(\text{aq}) + \text{CaCl}_2(\text{aq}) \rightarrow 2\text{KCl}(\text{aq}) + \text{CaCO}_3(\text{s})$

#### ■ WORKED EXAMPLE 14.1

- 1  $0.396 \text{ mol L}^{-1}$   
2 4.6%

#### ■ WORKED EXAMPLE 14.2

$0.12 \text{ mol L}^{-1}$

#### ■ WORKED EXAMPLE 14.3

- 1  $0.0304 \text{ mol L}^{-1}$   
2 38.1%  
3 3.75%

#### ■ CHECK YOUR UNDERSTANDING 14.5

- 4 a  $2.87 \times 10^{-3} \text{ mol}$  (in 25 mL)  
b  $0.0115 \text{ mol}$   
c  $0.0336 \text{ g mL}^{-1}$   
5  $0.0844 \text{ mol L}^{-1}$   
6 a 38.3%  
b  $1.85 \text{ g}$

#### ■ WORKED EXAMPLE 14.4

- 1 a 3.5 ppm  
b 1.5 ppm  
2 b 3.6 ppm

#### ■ CHECK YOUR UNDERSTANDING 14.6

- 5 b  $2.7 \text{ mg L}^{-1}$   
6 a 600 ppm  
b 60 000 ppm  
7 b Unknown site 1 =  $0.056 \text{ mg L}^{-1}$   
Unknown site 2 =  $0.025 \text{ mg L}^{-1}$

#### ■ CHAPTER REVIEW QUESTIONS

- 3 a  $\text{BaCl}_2(\text{aq}) + \text{Na}_2\text{SO}_4(\text{aq}) \rightarrow 2\text{NaCl}(\text{aq}) + \text{BaSO}_4(\text{s})$   
b  $3\text{CuSO}_4(\text{aq}) + 2\text{K}_3\text{PO}_4(\text{aq}) \rightarrow \text{Cu}_3(\text{PO}_4)_2(\text{s}) + 3\text{K}_2\text{SO}_4(\text{aq})$

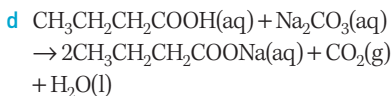
- c  $\text{CaCl}_2(\text{aq}) + 2\text{NaNO}_3(\text{aq}) \rightarrow 2\text{NaCl}(\text{aq}) + \text{Ca}(\text{NO}_3)_2(\text{aq})$   
d  $\text{AgNO}_3(\text{aq}) + \text{KBr}(\text{aq}) \rightarrow \text{AgBr}(\text{s}) + \text{KNO}_3(\text{aq})$   
e  $\text{Pb}(\text{NO}_3)_2(\text{aq}) + 2\text{KI}(\text{aq}) \rightarrow \text{PbI}_2(\text{s}) + 2\text{KNO}_3(\text{aq})$   
7 a  $[\text{CuCl}_4]^{2-}$   
8 The solution contains the  $\text{CO}_3^{2-}$  and  $\text{Cl}^-$  anions.  
9  $0.117 \text{ mol L}^{-1}$   
10 a  $\text{Ag}^+(\text{aq}) + \text{Cl}^-(\text{aq}) \rightarrow \text{AgCl}(\text{s})$   
b  $1.38 \times 10^{-3} \text{ mol}$  (in 25 mL)  
c  $0.0552 \text{ mol L}^{-1}$   
d  $0.552 \text{ mol L}^{-1}$   
e  $32.3 \text{ g L}^{-1}$   
11 a  $1.97 \times 10^{-3} \text{ mol}$   
b 0.115 g  
c 95.8%  
13 b A = 1.7 ppm; B = 5.1 ppm;  
C = 7.5 ppm (all  $\pm 0.1$ )  
14 A = 4.7 ppm, 1.2% (w/w); B = 3.5 ppm,  
0.9% (w/w); C = 6.2 ppm, 1.6% (w/w)  
15 a i 0.437 g  
ii 97.1%  
16 a i 196 mg  
ii 42.9 mg  
17 b  $0.044 \text{ mol L}^{-1}$   
18 a 0.05 ppm  
b 5 ppm

### CHAPTER 15

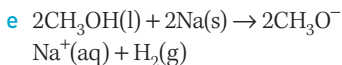
#### ■ CHECK YOUR UNDERSTANDING 15.1

- 2 a Alkene; *trans*-2-pentene  
b Carboxylic acid; propanoic acid  
c Alcohol; 2-butanol  
d Carboxylate anion; sodium butanoate  
3 a  $\text{Br}_2(\text{aq}) + \text{CH}_2=\text{CH}-\text{CH}_3(\text{l}) \rightarrow \text{CH}_2\text{BrCHBrCH}_3(\text{l})$   
Products: 1,2-dibromopropane  
b  $2\text{CH}_3\text{CH}_2\text{CH}_2\text{CH}_2\text{OH}(\text{l}) + 2\text{Na}(\text{s}) \rightarrow 2\text{CH}_3\text{CH}_2\text{CH}_2\text{CH}_2\text{O}^-\text{Na}^+(\text{aq}) + \text{H}_2(\text{g})$   
Products: Sodium butoxide and hydrogen gas  
c  $\text{CH}_3\text{CH}_2\text{OH}(\text{aq}) + \text{HCOOH}(\text{aq}) \rightarrow \text{HCOOCH}_2\text{CH}_3 + \text{H}_2\text{O}(\text{l})$   
Products: ethyl methanoate and water





Products: sodium butanoate, carbon dioxide gas and water



Products: Sodium methoxide and hydrogen gas

4 a carboxylic acid, an alcohol, and concentrated sulfuric acid

6 a A is water  
B is hexene  
C is pentane  
D is ethanol

#### WORKED EXAMPLE 15.1

- 1  $15 = \text{CH}_3^+$   
29 =  $\text{CH}_2\text{CH}_3^+$   
41 =  $\text{CH}_2\text{CHCH}_2^+$   
43 =  $\text{CH}_3\text{CH}_2\text{CH}_2^+$   
57 =  $\text{CH}_3\text{CH}_2\text{CH}_2\text{CH}_2^+$

#### CHECK YOUR UNDERSTANDING 15.3

3 The parent peak

#### WORKED EXAMPLE 15.2

- 1 There are four hydrogen environments.  
2 There are two hydrogen environments.

#### WORKED EXAMPLE 15.3

- 1 There are four carbon environments.  
2 There are two carbon environments.

#### CHECK YOUR UNDERSTANDING 15.4

- 1  $^1\text{H}$  and  $^{13}\text{C}$   
2 Radio waves  
5 a  $^1\text{H}$  NMR: 1  $^{13}\text{C}$  NMR: 1  
b  $^1\text{H}$  NMR: 1  $^{13}\text{C}$  NMR: 1  
c  $^1\text{H}$  NMR: 3  $^{13}\text{C}$  NMR: 2  
d  $^1\text{H}$  NMR: 4  $^{13}\text{C}$  NMR: 4  
e  $^1\text{H}$  NMR: 1  $^{13}\text{C}$  NMR: 1  
f  $^1\text{H}$  NMR: 4  $^{13}\text{C}$  NMR: 4  
g  $^1\text{H}$  NMR: 2  $^{13}\text{C}$  NMR: 2  
h  $^1\text{H}$  NMR: 5  $^{13}\text{C}$  NMR: 5  
i  $^1\text{H}$  NMR: 3  $^{13}\text{C}$  NMR: 3

#### WORKED EXAMPLE 15.4

- a  $0.325 \text{ mol L}^{-1}$   
b  $0.0975 \text{ mol L}^{-1}$

#### CHECK YOUR UNDERSTANDING

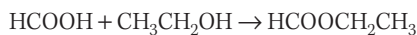
15.5/15.6/15.7

- 1 IR  
3 Diatomic molecules like  $\text{O}_2$  or  $\text{N}_2$

#### CHAPTER REVIEW QUESTIONS

- 4 IR  
6 Mass spectroscopy  
10 a  $\text{C}_3\text{H}_7\text{Cl}$   
b Parent peak is 78 (which is the molecular mass)  
f The most likely isomer is the second one.  
13 1, due to symmetry

- 16 a  $\text{C}_3\text{H}_6\text{O}_2$   
c ii C—H band at  $3000 \text{ cm}^{-1}$   
C—C band at  $1100 \text{ cm}^{-1}$   
C=O band at about  $1700 \text{ cm}^{-1}$   
d  $\text{CHOOCH}_2\text{CH}_3$  ethyl methanoate; flavourings: esters  
e There are three H environments.  
f Ethanol and methanoic acid; esterification or condensation



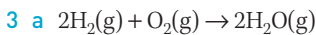
- 20  $^{13}\text{C}$  NMR: Ethanol: Spectra a; Ethanoic acid: Spectra b; Ethyl ethanoate: Spectra c  
IR: Ethanol: Spectra d; Ethanoic acid: Spectra f; Ethyl ethanoate: Spectra e

Mass spectra: Ethanol: Spectra h; Ethanoic acid: Spectra i; Ethyl ethanoate: Spectra g

- 21 a  $\text{C}_6\text{H}_{13}\text{NO}_2$   
b with both N and O: amino acids

### CHAPTER 16

#### CHECK YOUR UNDERSTANDING 16.1



#### WORKED EXAMPLE 16.1

- 1 2.50 g  
2 1.25 kg

#### WORKED EXAMPLE 16.2

- 1 63.9%  
2 34.8%

#### WORKED EXAMPLE 16.3

- 1 93.8%  
2 97.7%

#### CHECK YOUR UNDERSTANDING 16.3

- 2 To the right.  
3 100%  
5 b Temperature:  $400\text{--}450^\circ\text{C}$   
Pressure: approximately 200 atm  
Catalyst  
7 46.8%  
8 96.4%  
9 a  $\text{H}_2(\text{g}) + \text{Cl}_2(\text{g}) \rightleftharpoons 2\text{HCl}(\text{g})$   
d chlorine  
e 3.085 kg  
10 a 0.95 g  
b 1.5%

#### CHAPTER REVIEW QUESTIONS

- 10 a i drive the reaction to the left, reducing yield  
ii drive the reaction to the right, increasing yield  
b Low pressure and increased temperature  
c i oxygen  
ii 100 mL carbon monoxide  
11 a More  $\text{CaCO}_3$  has been added than needed.  
12 73.2%  
13 a 45.1%  
b forgery

#### END-OF-MODULE 8 REVIEW

- 1 B                    5 C                    9 B  
2 A                    6 B                    10 C  
3 D                    7 C  
4 C                    8 A  
11 b i  $\text{C}_3\text{H}_6\text{Br}_2$   
13 a  $\text{A} = \text{Ca}^{2+}$ ,  $\text{B} = \text{Fe}^{3+}$ ,  $\text{C} = \text{Ag}^+$ ,  
 $\text{D} = \text{Mg}^{2+}$ ,  $\text{E} = \text{Pb}^{2+}$   
b  $\text{Mg}^{2+}$   $\text{Ag}^+$   
14 a 9.308%  
15 a  $4.5 \times 10^{-3} \text{ mol L}^{-1}$   
b within guidelines value  
16 b  $3.5 \times 10^{-3} \text{ mg L}^{-1}$   
17 a 445 millimicrons  
18 b  $15 = [\text{CH}_3]^+$   
 $28 = [\text{CH}_3\text{CH}]^+$   
 $43 = [\text{CH}_3\text{CH}_2\text{CH}_2]^+$   
20 92.5%

## A

**absorbance (A)** measure of the amount of light absorbed by a sample in UV-vis spectrophotometry.  $A = \log_{10}(I_0/I)$ . (p. 435)

**absorption band** a trough observed at a particular wavenumber in the infrared spectra. (p. 471)

**absorption indicator** indicator that is absorbed onto a precipitate and used in precipitation titrations to indicate the end point. (p. 428)

**accuracy** depends on the measuring instrument that is used; a mass balance that measures to 0.001 g is a more accurate instrument than a mass balance that measures to 0.1 g. (p. 191)

**acid** substance that in solution produces hydrogen ions,  $H^+$ . (p. 119)

**accurate** how close a measurement is to a standard or known value. (p. 11)

**acid-base indicator** a substance that changes colour in solution depending on whether the solution is acidic or basic. (p. 122)

**acid dissociation constant ( $K_a$ )** the equilibrium expression of a weak acid. (p. 74)

**acidic solution** a solution in which  $[H_3O^+] > [OH^-]$ . (p. 159)

**acid rain** rain of low pH; results when chemicals such as sulfur and nitrogen oxides are released, leading to the production of acids in the atmosphere. (p. 503)

**activated complex** an unstable state of high enthalpy where the bonds of the reactants have been broken but the new bonds of the products have yet to form. (p. 32)

**activation energy** the energy needed to break the reactant's bond in order to form the products. (p. 12)

**addition polymer** a polymer that forms by molecules adding together without the loss of any atoms. (p. 371)

**addition reaction** a reaction in which atoms are added to a molecule by breaking a double or triple bond. (p. 296)

**alcohol** organic compound containing the hydroxyl functional group. (p. 263)

**aldehyde** organic compound containing the carbonyl functional group at the end of the molecule chain. (p. 263)

**aliphatic compound** hydrocarbon that does not contain a benzene ring. (p. 240)

**aliquot** a specifically measured portion of a sample (p. 217)

**alkali** a soluble base. (p. 121)

**alkaline solution** a solution in which  $[H_3O^+] < [OH^-]$ . (p. 159)

**alkaloid** basic compound derived from amino acids. (p. 230)

**alkanes** family of hydrocarbons containing carbon chains with only single bonds between carbons. (p. 240)

**alkenes** family of hydrocarbons containing carbon chains with at least one double bond between carbons. (p. 240)

**alkoxide** an anion formed when an alcohol loses the H from the alcohol functional group. (p. 450)

**alkyl halide** a hydrocarbon molecule with a halogen atom attached to the main chain. (p. 322)

**alkynes** family of hydrocarbons containing carbon chains with at least one triple bond between carbons. (p. 240)

**alpha-amino acid** an amino acid in which the amine and carboxyl functional groups are attached to the same carbon atom; proteins can only form from alpha-amino acids. (p. 394)

**alpha-carbon** the carbon atom of an amino acid to which is attached the amino and carboxyl functional groups, a hydrogen and a side chain. (p. 394)

**alternative fuel** fuel that is not derived from fossil fuels. (p. 333)

**amide** organic compound containing a carbonyl and amine group combined into an amide functional group. (p. 263)

**amide link** the functional group produced by the condensation reaction between a  $-NH_2$  functional group and a  $-COOH$  functional group. (p. 389)

**amine** organic compound containing an amine functional group ( $-NH$ ). (p. 263)

**amino** alternative name for the amine functional group. (p. 280)

**amino acid** organic molecule containing a carboxyl and amine functional group on the alpha carbon; the building block of a proteins. (p. 280)

**amphiprotic** a substance that can gain or lose a hydrogen ion to act as an acid or a base. (p. 138)

**amorphous** substances that do not have an extended ordered arrangement of atoms. (p. 373)

**amphoteric** a substance that can act as either an acid or a base depending on the other reactants. (p. 124)

**anaerobic** without oxygen. (p. 331)

**analgesic** provides relief from pain. (p. 229)

**analyte** the solution of unknown concentration that will be analysed. (p. 198)

**anhydrous** salts that do not have water of crystallisation. (p. 84)

**anionic detergent** molecule with a long chain hydrocarbon structure and a negatively charged head. (p. 353)

**aqueous solution** a solution where the solvent is water. (p. 94)

**aromatic hydrocarbon** molecule that contains a benzene ring. (p. 240)

**atactic** the random arrangement of side groups on both sides of a polymer chain. (p. 379)

**atomic absorption spectroscopy (AAS)** an analytical technique for determining the unknown concentration of an element based on the amount of light it absorbs. (p. 434)

**atomic mass unit (amu)** the approximate mass of 1 nucleon; it is measured in a mass spectrum and carbon-12 is assigned an amu of 12. (p. 456)

## B

**back titration** a method used to determine the mass or concentration of a substance that is not able to be determined directly. (p. 218)

**ball and stick model** structure where atoms are represented by balls and the bonds by sticks, showing arrangement of atoms. (p. 239)

**base peak** the most common peak in a mass spectrum; assigned a value of 100% with other peaks relative to it. (p. 456)

**base** substance that contains either the hydroxide ion ( $OH^-$ ) or the oxide ion ( $O^{2-}$ ) or that in solution produces the hydroxide ion. (p. 119)

**base dissociation constant** the equilibrium expression of a weak base. (p. 74)

**benzene** molecule with six carbons in circle, containing a ring of delocalised electrons. (p. 240)

**biodiesel** diesel produced from an organic source like crops or waste oils. (p. 333)

**biofuel** fuel derived from an organic source like crops or sugars. (p. 333)

**biopolymer** a polymer made totally or in large part by living organisms. (p. 508)

**bond energy** energy required to break a chemical bond. (p. 328)

**buffer** a solution of a weak acid and its conjugate base (or vice versa) that can counteract the addition of an acid or base to maintain a constant pH. (p. 221)

**buffer capacity** the extent to which a buffer is able to counteract the addition of an acid or base. (p. 222)

**by-product** a product resulting from a chemical process that is not the desired end product, but still has commercial value. (p. 493)

## C

**calibration curve** a graph constructed during atomic absorption spectroscopy/colourimetry that plots known concentrations against the absorbance values; used to determine the concentration of an unknown substance. (p. 436)

**calorimetric** experiments that measure changes in temperature. (p. 317)

**calrimetry** the process of measuring the amount of heat released or absorbed during a chemical reaction. (p. 316)

**carbonyl** functional group containing a carbon atom bonded to an oxygen atom with a double bond. (p. 273)

**carboxyl** functional group containing a carbonyl and hydroxyl group combined. (p. 276)

**carboxylate ion** the ion remaining when a carboxylic acid donates a proton in an acid-base reaction. (p. 346)

**carboxylic acid** organic molecule containing the carboxyl functional group. (p. 263)

**catalyst** substance that speeds up the rate of a reaction without being consumed in the reaction. (p. 296)

**catalytic cracking** the process in which high molecular weight (high boiling point) fractions from crude oil are broken into lower molecular weight (lower boiling point) substances using a catalyst and moderate temperatures and pressures. (p. 304)

**cationic detergent** molecule with a long chain hydrocarbon structure and a positively charged head. (p. 553)

**chan somer** isomers with different placement of substituents on the main chain. (p. 253)

**change n enthalpy** as the heat absorbed per mole of specified reactant or product when the reaction occurs at constant pressure; represented by the symbol  $\Delta H$ . (p. 128)

**chemical change** a change that produces new substances. (p. 28)

**chemical shift,  $\delta$  (delta)** in NMR spectroscopy, it is the relative frequency that an odd nucleon will spin in a magnetic field compared to the standard tetramethylsilane (TMS); measured in ppm. (p. 463)

**chemical system** the chemicals involved in a reaction. (p. 28)

**chromophore** group of atoms responsible for UV-vis adsorption. (p. 475)

**closed system** a chemical system in which no substances are able to enter or leave. (p. 28)

**colliion theory** the theory stating that for a reaction to proceed, the reactant particles must collide with sufficient energy and an appropriate orientation. (p. 32)

**colorimeter** instrument used in colourimetry that measures the amount of a specific wavelength of light absorbed. (p. 438)

**colorimetry** an analytical technique for determining the concentration of a coloured ion or compound based on the amount of light it absorbs. (p. 438)

**combustion** burning in oxygen. (p. 491)

**common ion effect** decrease in the solubility of an ionic compound due to the addition of a soluble salt containing one of the ions present in the precipitate that is already in dynamic equilibrium with its ions. (p. 108)

**complementary colour** pairs of colours that cancel each other out when combined. (p. 438)

**complete ionic equation** equation that shows all the ions that are present in a reaction mixture, including those undergoing reaction as well as the spectator ions. (p. 95)

**complexation reaction** reaction in which a complex ion or compound is formed. (p. 417)

**complex ion** formed when one or more small molecules or ions attach themselves to a central cation, resulting in a complex with different properties to the individual species. (p. 417)

**condensaion polymer** a polymer that forms by the elimination of a small molecule (often water) when monomers join together. (p. 387)

**condensation reaction** chemical reaction where the functional groups of two molecules join and a small molecule, usually water, is released. (p. 344)

**condensed formula** organic structure showing arrangement of carbon structure but condensing alkyl groups and side chains. (p. 241)

**conductometric titration** titration that uses change in conductivity to determine equivalence point. (p. 206)

**conjugate acid (of a base)** the acid that is formed when a base accepts a proton from an acid. (p. 145)

**conjugate base (of an acid)** the base that is formed when an acid donates a proton to a base. (p. 145)

**conjugate air** compound that differs by one proton ( $H^+$ ); for example,  $HCl/Cl^-$ . (p. 145)

**contact process** a series of reactions to produce sulfuric acid. (p. 491)

**controlled variable** variable kept constant so that it does not influence the outcome of the experiment. (p. 8)

**convergent sequence** a sequence in which the reaction steps run parallel before the reactants of two separate pathways are combined. (p. 491)

**copolymer** a polymer consisting of two or more different monomers. (p. 380)

**cross-linking** the process by which two or more polymer chains are joined together to form an extended two-dimensional network. (p. 383)

**crude oil** a mixture of hydrocarbons mined from the earth. (p. 304)

**crystalline** a substance with an ordered arrangement of atoms, ions or molecules in the solid form. (p. 373)

**cyclic hydrocarbon/alicyclic hydrocarbon** hydrocarbon in which the carbon atoms have joined to form a closed ring structure. (p. 241)

## D

**dependent variable** variable being measured in an experiment. (p. 8)

**depth study** an investigation or activity completed by a student or students to more deeply explore a topic from the Year 12 Chemistry course that they find interesting. (p. 2)

**derived data** deduced from raw data by mathematical manipulation, such as graphs and equations. (p. 15)

**detector** a device used to measure light or particles; used spectroscopy. (p. 435)

**dimer** structure formed by two carboxylic acid molecules forming hydrogen bonds between them. (p. 277)

**dipeptide** a molecule formed by the joining of two amino acids in a condensation reaction by a peptide link. (p. 395)

**diprotic** a substance that can donate two protons to a base. (p. 157)

**disaccharide** simple sugar molecule with two joined carbon ring structures/ monosaccharides; a carbohydrate, such as sucrose, maltose and lactose, formed by a condensation reaction to join by a glycosidic link between two monosaccharides. (p. 330)

**dissociation constant** the equilibrium expression for either the ionisation of a weak acid or the dissociation of a weak base. (p. 74)

**dissociation reaction** a reaction in which an ionic substance separates into ions in a solution. (p. 74, 152)

**dissolution** dissolving of a gas, liquid or solid into a liquid or gas. (p. 307)

**dynamic equilibrium** a state in which there are no macroscopic changes to the system since the amount of reactants and products remains constant since the rates of the forward and reverse reactions are equal. (p. 29)

## E

**electron configuration** the arrangement of electrons (in their energy levels) around an atom. (p. 409)

**empirical** able to be verified by gaining evidence through observation and experimentation. (p. 2)

**emulsifier** chemical that allows immiscible liquids to dissolve. (p. 353)

**emulsion** mixture of two normally immiscible liquids. (p. 353)

**endothermic** a chemical or physical change where the chemical energy of the products is greater than the chemical energy of the reactants; heat energy is absorbed. (p. 128)

**endothermic reaction** a reaction that absorbs energy from the surroundings; the products have more energy than the reactants. (p. 46, 494)

**end point** the physical sign that indicates that the equivalence point has been reached; achieving the correct end point depends on using an appropriate method where there is a physical change at the appropriate point. (p. 191)

**enhanced greenhouse effect** warming of the atmosphere due to the increased amount of CO<sub>2</sub> being released into the atmosphere due to human activity, mainly burning of fossil fuel. (p. 306)

**enthalpy** the total energy possessed by a chemical substance at constant pressure. (p. 25, 128)

**enthalpy of combustion** heat energy released when 1.00 mole of fuel is combusted in excess oxygen at standard atmospheric pressure. (p. 317)

**entropy** measure of the randomness or disorder or chaos of a substance or a system. (p. 25)

**enzyme** a protein that catalyses (speeds up the rate of) chemical reactions in living organisms by orienting molecules in the correct manner and lowering the activation energy. (p. 330, 496)

**equilibrium** the state for a reversible reaction in a closed system when the forward and reverse reactions occur at the same rate. (p. 25, 492)

**equilibrium constant ( $K$  or  $K_{eq}$ )** the value of the ratio between the concentration of the products and the concentration of reactants. (p. 54)

**equilibrium expression** the ratio of the concentration of products to reactants raised to the power of the coefficients of the species in the balanced chemical equation for concentrations of solutions when the reaction has reached equilibrium. (p. 54)

**equivalence point** the point when the reactants are present in the ratio shown by the mole ratio in the balanced chemical equation for the reaction. (p. 190)

**ester** organic molecule containing an ester functional group —COO—. (p. 263)

**excess reactant/excess reagent** the reactant that is left over when the limiting reactant is used up. (p. 496)

**excited state** when an electron is at a higher energy level than the ground state due to absorption of energy. (p. 409)

**exothermic** a chemical or physical change where the chemical energy of the products is less than the chemical energy of the reactants; heat energy is released. (p. 128)

**exothermic reaction** a reaction that releases heat energy to the surroundings due to the products having less energy than the reactants. (p. 46, 494)

**expanded formula** shows atoms in a molecule arranged in relation to other atoms. (p. 241)

## F

**falsifiable** able to be disproved. (p. 2)

**fatty acid** long-chain carboxylic acids; can be saturated or unsaturated. (p. 334)

**feedstock** chemical or substance used to manufacture useful materials and chemicals. (p. 258)

**fermentation** process of converting simple sugars into ethanol in an anaerobic environment. (p. 329)

**fingerprint region** area of IR spectrum characteristic for a particular substance; corresponds to a wavenumber less than 1400 cm<sup>-1</sup>. (p. 471)

**flashpoint** the lowest temperature at which a liquid can form an ignitable mixture in air near the surface of the liquid. (p. 292)

**fluoroalkane** alkane with a fluorine atom as a substituent. (p. 328)

**forward reaction** the process of the reactants forming the products. (p. 29)

**fractional distillation** process of separation of a liquid based on the boiling points of the components. (p. 304)

**functional group isomer** molecule with the same molecular formula but different functional group and structural formula. (p. 274)

**functional group** group of atoms in a particular arrangement shared by a family of compounds. (p. 263)

## G

**glass cuvet** a small test tube, often with a square base, with two clear sides through which light passes in spectroscopic and colourimetry analysis. (p. 438)

**glycerol** an alcohol, 1,2,3-propantriol. (p. 335)



**glycosidic link** the —C—O—C— group that is produced when two monosaccharides join. (p. 396)

**gravimetric analysis** analytical technique that uses mass to determine the amount of a substance. (p. 431)

**green chemistry** the area of chemistry that aims to reduce the impact of chemistry on the environment. (p. 505)

**ground state** when all the electrons of an atom are in their lowest possible energy levels. (p. 409)

## H

**Haber process** the industrial process that combines nitrogen and hydrogen gases to produce ammonia on a large scale. (p. 495)

**haloalkane** organic molecules containing one or more halogen atoms. (p. 250, 328)

**halogenation** addition of halogens to a molecule. (p. 297)

**hard water** water with a high concentration of magnesium and calcium ions. (p. 354)

**heating mantle** equipment used to heat a reaction mixture without a naked flame present. (p. 345)

**heat of reaction** the amount of energy absorbed or released in a reaction. (p. 494)

**homologous series** family of related compounds that share key chemical properties. (p. 263)

**hydrocarbon** molecule made up of only hydrogen and carbon. (p. 240)

**hydrogenation** addition of hydrogen to a molecule. (p. 296)

**hydrogen bonding** when a hydrogen attached to a N, O, or F on one molecule is attracted to a N, O or F on another molecule. (p. 83)

**hydrogen halide** molecules with a hydrogen atom and a halogen atom like chlorine or bromine. (p. 297)

**hydronium ion (H<sub>3</sub>O<sup>+</sup>)** ion produced when a hydrogen ion (H<sup>+</sup>) attaches to a water molecule. (p. 124)

**hydrophilic** 'water loving' substance that forms hydrogen bonds with water. (p. 353)

**hydrophobic** 'water hating' substance that does not form hydrogen bonds with water. (p. 353)

**hydroxyl** —OH group found in all alcohol compounds. (p. 263)

**hypothesis** tentative prediction, usually based on an existing model or theory; also a tentative explanation of an observation based on an existing model or theory. (p. 3)

**immiscible** liquids that do not dissolve in each other. (p. 345)

**incomplete combustion** combustion performed with limited oxygen producing carbon monoxide and carbon. (p. 300)

**independent variable** variable that is changed or manipulated by the experimenter. (p. 8)

**infrared radiation** part of the electromagnetic spectrum; higher wavelength than visible light; responsible for the heat trapped in the Earth's atmosphere. (p. 306)

**inhbtor** substance that prevents a reaction from continuing. (p. 296)

**ntator** a chemical species that reacts with a monomer to form an intermediate compound that enables the linking of monomers to form a polymer; it is incorporated into the polymer so is not a catalyst. (p. 372)

**intermediate** a product of one reaction that is used as a reactant in the next reaction of a reaction pathway. (p. 489)

**ion-dipole bond** attraction between a positive or negative ion with the oppositely charged end of a polar covalent molecule. (p. 83)

**ionic product** reaction quotient for a salt solution of any concentration where the product of the concentration of the ions raised to their stoichiometric powers is less than the solubility product (i.e. dynamic equilibrium has not been reached). (p. 73, 106)

**ionisation reaction** a chemical reaction when an uncharged molecule becomes an ion. (p. 152)

**sotactic** the orderly arrangement of side groups on the same side of a polymer chain. (p. 378)

**isotope** variant of an element that has a different number of neutrons; for example, carbon-12 and carbon-14. (p. 454)

## K

**ketone** organic compound containing the carbonyl functional group in the middle of the molecule chain. (p. 263)

## L

**λ max** wavelength (nm) of light in a UV-visible spectrum at which there is maximum absorbance. (p. 476)

**leaching** removing a substance from a solid by dissolving it in a liquid. (p. 92)

**Le Chatelier's principle** a principle that predicts the effect of changes to a system at equilibrium: if a change is made to a system at equilibrium, the system will react to partially counteract the change. (p. 39)

**ligand** molecule or ion that binds to a central metal ion to form a complex ion. (p. 84)

**limiting reactant/limiting reagent** the reactant that is used up first in a reaction and therefore limits the amount of product produced. (p. 496)

**limit of reading** smallest unit of measurement able to be determined on a measuring instrument. (p. 13)

**linear sequence** a sequence in which the reaction steps follow one after the other in a linear progression. (p. 491)

**literature review** report and critical analysis of information from secondary sources on a topic of interest. (p. 7)

**logbook** record of an experiment or investigation kept by the scientist performing the experiments; it is a legal record of the experiments and their results. (p. 6)

## M

**main chain** backbone of a hydrocarbon molecule. (p. 243)

**Markovnikov's rule** a hydrogen atom will add across a double bond to the carbon that already has the greater number of hydrogen atoms. (p. 297)

**measurand** quantity being measured. (p. 13)

**micelle** structure formed by soap/detergent molecules to allow non-polar substances to dissolve in water. (p. 357)

**model** representation of a system or phenomenon that explains an aspect or aspects of the system or phenomenon; may be mathematical equations, a computer simulation, a physical object, text or other form. (p. 4)

**molality** the number of moles of solute per litre of solution measured in moles per litre (mol L<sup>-1</sup>). (p. 152)

**molar solubility** number of moles of solute that can be dissolved in one litre of solution before the solution becomes saturated. (p. 102)

**molecular formula** gives the number of atoms in a molecule, but does not give information on arrangement. (p. 241)

**molecular ion (M<sup>+</sup>)** the largest peak (*m/z*) in a mass spectrum; generally corresponds to the molecular mass of the molecule. (p. 455)

**mole fraction** ratio of the number of moles of a particular gas to the number of moles of gas in total present in a gaseous mixture. (p. 75)

**monochromator** a device used in atomic absorbance spectroscopy to select light of a single wavelength. (p. 435)

**monomer** a small molecule that combines with other monomers to make a polymer. (p. 369)

**monoprotic** a substance that can donate one proton to a base. (p. 157)

**monosaccharide** simple sugar molecules with a single closed carbon ring structure; commonly exists as a five- or six-membered ring with hydroxyl groups attached. (p. 329)

**multistep reaction** a chemical reaction that is made up of many steps, with each step having its own reactants, products and activation energy. (p. 490)

## N

**natural gas** mixture of simple alkanes, mostly methane, but also ethane, propane, butane and pentane. (p. 305)

**neighbouring atom** the carbon or atom next to the atom holding the protons (hydrogen atoms) in question. (p. 466)

**net ionic equation** equation showing the actual ions that are undergoing reaction without specifying the compounds from which they come. (p. 95)

**neutral** neither acidic nor basic; pH of 7. (p. 125)

**neutralisation** a reaction between an acid and a base to form a salt and water. (p. 125)

**neutral solution** a solution in which  $[H_3O^+] = [OH^-]$ . (p. 159)

**nomenclature** a set of rules used for naming chemical compounds and determining their formula. (p. 119)

**non-ionic detergent** molecule with a long chain hydrocarbon structure and an uncharged but polar head. (p. 353)

**nucleon** a general name for both protons and neutrons. (p. 461)

## O

**octane rating** measure of the compression that a fuel can undergo before igniting. (p. 334)

**open system** a chemical system in which substances are able to enter or leave. (p. 28)

**organic acid** acid with an organic/carbon-based structure. (p. 349)

**organic base** base with an organic/carbon-based structure. (p. 349)

**organic chemistry** branch of chemistry devoted to carbon-based compounds. (p. 239)

**organic compounds** covalent compounds with a carbon and hydrogen base that may also contain oxygen, halogens or other elements. (p. 239)

**outlier** data point that is distant to the other data points in a sample. (p. 13)

**oxyacid** inorganic acid in which the anion contains oxygen. (p. 120)

## P

**parallax error** an error in measurement due to the observer's position relative to the measuring scale; if the reading is taken at an angle to the scale, then an error is introduced. (p. 191)

**parent molecular ion** molecular ion that gives the molar mass of the original compound in mass spectrometry (p. 456)

**parent peak** also called the molecular ion. (p. 457)

**partial pressure** the pressure exerted by a single gas in a gas mixture. (p. 39, 75)

**peptide link** the functional group produced by the condensation reaction between a  $-NH_2$  functional group and a  $-COOH$  functional group of different amino acids. (p. 395)

**percentage ionisation** the percentage of acid molecules that have ionised in water. (p. 170)

**percentage yield** the percentage of the possible product that is actually produced. (p. 498)

**pH scale** a scale that measures the acidity and alkalinity of a solution, based on the concentration of hydrogen ions in the solution. (p. 146)

**physical change** a change where no new substances are formed. (p. 28)

**plastic** a material that is capable of being moulded by heat and pressure. (p. 368)

**plasiiser** a small molecule inserted between polymer chains to decrease the intermolecular forces between the chains and which holds them further apart. (p. 377)

**polyamide** organic molecule with repeating structures joined with an amide functional group; formed by a condensation polymerisation reaction between an amine group ( $-NH_2$ ) and a carboxylic acid group ( $-COOH$ ). (p. 283)

**polyester** synthetic polymers formed by a condensation polymerisation reaction between an alcohol group ( $-OH$ ) and a carboxylic acid group ( $-COOH$ ). (p. 342, 387)

**polymer** a substance consisting of long macromolecular chains. (p. 368)

**polymerisation** a chemical reaction in which many small molecules combine to form one large molecule. (p. 290)

**polypeptide** a long chain of amino acids joined by peptide links. (p. 350)

**polyprotic** a substance that can donate more than one proton to a base. (p. 157)

**polysaccharide** carbohydrates with multiple monosaccharide structures chemically joined to make long chain molecules (such as starch and cellulose). (p. 330)

**polyunsaturated** molecules that contain multiple double or triple bonds. (p. 296)

**positional isomer** isomer with a different position of the functional group. (p. 253)

**precipitate** formation of an insoluble ionic compound from a solution. (p. 94)

**precipitation reaction** a chemical reaction where two solutions are mixed to form an insoluble ionic compound. (p. 94)

**precision** the clustering of measurements around the mean. (p. 13)

**primary alcohol** alcohol molecule where the hydroxyl functional group is attached to a carbon attached to one other carbon. (p. 266, 267)

**primary amide** amide molecule where the amide functional group is attached to a carbon attached to one other carbon. (p. 283)

**primary amine** amine molecule where the amine functional group is attached to a carbon attached to one other carbon. (p. 281)

**primary haloalkane** haloalkane molecule where the halogen atom is attached to a carbon attached to one other carbon. (p. 328)

**primary source data/investigation** data that you have measured or collected yourself, or an investigation based on that data. (p. 5)

**primary standard** a solution of accurately known concentration that remains stable under common laboratory conditions for extended periods of time. (p. 196)

**protein** biological molecule formed by condensation polymerisation of amino acids. (p. 280, 393)

**protonated amine** an amine that has accepted a proton in an acid–base reaction. (p. 351)

**purty** the degree or percentage to which a mixture contains only the desired synthesised compound or element. (p. 490)

## Q

**quantitative analysis** any method for determining the amount of chemical in a sample. (p. 190)

## R

**radical** a molecule with an unpaired electron; it is highly reactive. (p. 455)

**raw data** original data taken directly from a measurement system. (p. 12)

**raw material** non-processed material that are used to produce something else. (p. 362)

**reaction mechanism** the sequence of chemical reactions for an overall chemical change (reaction pathway). (p. 490)

**reaction pathway** the sequence of chemical reactions for an overall chemical change (reaction mechanism). (p. 488)

**reaction quotient** ratio of the concentration of products to reactants raised to the power of the coefficients of the species in the balanced chemical equation for any concentrations of solution not at equilibrium. (p. 57)

**reflux** process of extended heating of a mixture without evaporative loss of reactants or products. (p. 345)

**reliable** when repeated measurements give the same result, within experimental uncertainty. (p. 10)

**reproducible** able to be repeated by different people at different locations with different instruments to give the same results. (p. 10)

**research question** specific question that a particular experiment or investigation is designed to answer. (p. 7)

**retrosynthetic analysis** a process for determining the reaction pathway for a synthesis reaction that involves starting with the product and working backwards by identifying simpler substances. (p. 490)

**reverse reaction** the reaction in which the products form the reactants. (p. 29)

**reversible reaction** a reaction in which the reactants become products and the products become reactants. (p. 28)

**R group** alkyl groups of varying length and structure; can be straight chain, branched, cyclic or aromatic. (p. 263)

## S

**saponification** chemical reaction involving the hydrolysis of fats to form soap ions. (p. 354)

**saturated** a solution at a particular temperature where no more solute can dissolve. (p. 35, 87)

**saturated compound** hydrocarbon with only single bonds between carbon atoms. (p. 240)

**saturated solution** solution in which no more of a particular solute can dissolve in a given quantity of solvent. (p. 87)

**scatter plot/graph** graphical representation of the relationship between the individual data points of two variables. (p. 16)

**scientific method** systematic process of observation, experimentation, measurement and analysis to either support or disprove a hypothesis. (p. 3)

**scum** solid precipitate formed by the reaction of soap ions with calcium and magnesium ions. (p. 359)

**SDS (Safety Data Sheet)** information on chemical structure, properties, hazards and precautions for safe use. (p. 290)

**secondary alcohol** alcohol molecules where the hydroxyl functional group is attached to a carbon attached to two other carbons. (p. 267)

**secondary amide** amide molecules where the amide functional group is attached to a carbon attached to two other carbons. (p. 283)

**secondary amine** amine molecules where the amine functional group is attached to a carbon attached to two other carbons. (p. 281)

**secondary haloalkane** haloalkane molecules where the halogen atom is attached to a carbon attached to two other carbons. (p. 328)

**secondary source data/investigation** data or information collected by someone else, or an investigation based on that data or information. (p. 5)

**self-ionisation constant ( $K_w$ )** the equilibrium expression that shows water ionising into two ions. (p. 159)

**separating funnel** equipment used to separate liquids of different density and/or polarity. (p. 345)

**shielding** the net effect of the electron shells and the neighbouring nuclei have on local electrical field felt by the proton or odd number in NMR spectroscopy. (p. 462)

**skeletal structure** shows a representation of the carbon chain arrangement, but not individual atom detail. (p. 241)

**solubility** the solubility of a substance is the maximum amount of that substance that can dissolve in 100 g of a particular solvent at a particular temperature. (p. 87)

**solubility curve** a graph that shows the relationship between the mass of solute that can dissolve in a given volume of solvent and temperature. (p. 87)

**solubility product** the equilibrium expression for a saturated salt solution (i.e. the ratio of the concentration of products to reactants raised to the power of the coefficients of the species in the balanced chemical equation for concentrations of solutions for a saturated salt solution). (p. 73, 100)

**space-filling model** structure that shows the relative sizes of atoms and their arrangement in a molecule. (p. 239)

**specific heat capacity** heat energy required to raise the temperature of 1 gram of a substance by 1 kelvin. (p. 129)

**spectator ion** a free ion that appears on both the reactant and product sides of an equation; it has not taken part in the chemical reaction. (p. 95)

**spin–spin coupling** the change in the local electrical field due to the presence of protons on the neighbouring carbons. (p. 466)

**splitting** the pattern seen in high-resolution NMR spectra due to the protons of the neighbouring atoms. (p. 466)

**spontaneous** a reaction that favours the forward reaction under the conditions as written; occurs when  $\Delta G$  is negative. (p. 25)

**standard enthalpy of neutralisation** the enthalpy change when solutions of an acid and alkali react together under standard conditions to produce exactly 1 mole of water. (p. 129)

**static equilibrium** a reaction that only occurs in one direction and stops when one of the reactants is used up. (p. 29)

**steady state** a state in which the properties remain constant. (p. 34)

**stereoregular polymer** a polymer with an ordered arrangement of side groups along the carbon backbone. (p. 379)



**strong acid** an acid that is completely or almost completely ionised in aqueous solution;  $K_a$  is large. (p. 152)

**strong base** a base that is completely or almost completely dissociated in aqueous solution;  $K_b$  is large. (p. 153)

**structural formula** formula that shows the structural arrangement of all atoms in a molecule. (p. 241)

**structura isomer** compounds with the same molecular formula but different structural formula. (p. 253)

**substituent** atom attached to the main chain of a hydrocarbon. (p. 244)

**substitution** replacement of an atom on a molecule. (p. 299)

**substitution reaction** chemical reaction involving replacement of an atom on a molecule. (p. 328)

**supersaturated solution** an unstable solution that has more than the maximum amount of solute dissolved in a given quantity of solvent; it has a higher amount of solute than the saturated solution. (p. 87)

**surface tension** elastic behaviour of a water surface giving it specific properties. (p. 352)

**surfactant** chemicals that reduce surface tension between two liquids. (p. 352)

**surroundings** substances around the chemical system but not involved in the reaction. (p. 28)

**syndiotactic** the alternating arrangement of side groups on each side of a polymer chain. (p. 379)

**synthesise** to make something; with respect to chemistry, to produce a specific product. (p. 488)

**systematic error** error that results in a consistent, predictable offset from the 'true value'; for example, a zero error. (p. 15)

## T

**tare** reset the balance to zero to measure only the contents of a container (p. 196)

**tertiary alcohol** alcohol molecules where the hydroxyl functional group is attached to a carbon attached to three other carbons. (p. 267)

**tertiary amide** amide molecules where the amide functional group is attached to a carbon attached to three other carbons. (p. 283)

**tertiary amine** amine molecules where the amine functional group is attached to a carbon attached to three other carbons. (p. 281)

**tertiary haloalkane** haloalkane molecules where the halogen atom is attached to a carbon attached to three other carbons. (p. 328)

**tetramethylsilane (TMS)** the standard used in NMR spectroscopy that is considered to have a zero shift; the protons (hydrogen atoms) present have the maximum shielding. (p. 463)

**thermal cracking** breaking a longer chain hydrocarbon into shorter chain hydrocarbons using high temperatures and pressures. (p. 305)

**thermoplastic** a polymer that can be melted and reshaped. (p. 369)

**thermosetting** a polymer that cannot be melted and reformed. (p. 369)

**titrant** the solution in a burette. (p. 198)

**titratable acidity** the total amount of acid present in wine as determined by titration. (p. 227)

**titration** a type of volumetric analysis that determines the equivalence point. (p. 190)

**toxin** substance that can cause harm to humans or even death. (p. 91)

**transesterification** reaction between an alcohol and carboxylic acid to produce an ester. (p. 335)

**triglyceride** plant or animal fats; esters made from fatty acid carboxylic acid chains. (p. 335)

**triprotic** a substance that can donate three protons to a base. (p. 157)

**trough** an absorption band in an IR spectra. (p. 471)

## U

**uncertainty** estimate of the range of values within which the 'true value' of a measurement or derived quantity lies. (p. 10)

**universal indicator** a mixture of different indicators that displays a range of colours when added to solutions of different pH. (p. 148)

**unpalatable substance** substance that has an unpleasant taste or smell or both. (p. 91)

**unsaturated compound** hydrocarbon with at least one multiple bond (double or triple) between carbon atoms. (p. 240)

**unsaturated solution** a solution where all of the solute dissolves; it has not reached dynamic equilibrium. (p. 87)

## V

**valid** ability to control all variables so that only one variable is changed. (p. 3)

**vaporised** when a substance is heated so that it turns into its atomic form. (p. 435)

**volatile** substances that are easily evaporated to form a vapour. (p. 292)

**volumetric analysis** analysis determining the concentration of a sample by measuring the volumes of each reactant that reacts and knowing the concentration of the other reactant. (p. 190)

**VSEPR theory (valence shell electron-pair repulsion theory)** theory that allows chemists to predict shapes of molecules and polyatomic ions; it postulates that pairs of valence electrons around an atom in a molecule arrange themselves spatially so as to get as far away from one another as possible and this determines the shape of the molecule. (p. 84)

**vulcanisation** the process of strengthening a material such as rubber by combining it with sulfur and other additives and then applying heat and pressure. (p. 383)

## W

**wavelength** a property of light related to the length of the wave that can give properties of light such as colour. (p. 409)

**wavenumber** the inverse of wavelength; number of waves per centimetre; used in IR spectra. (p. 470)

**weak acid** an acid in which only a small proportion of the molecules have ionised;  $K_a$  is small. (p. 73)

**weak base** a base in which only a small proportion of the molecules have dissociated;  $K_b$  is small. (p. 74)

**wettability** the ability of a surface to be wet by water molecules/droplets. (p. 353)

## Y

**yeast** a single-celled fungus. (p. 329)

**yield** the amount or percentage of the possible product that is actually produced. (p. 492)

## Z

**zeolite** a catalyst composed of aluminosilicate minerals. (p. 304)

- absorbance (A) 475
- acetate ions, testing for 421–422
- acetic acid 276–277, 279
- acetylene 249
- acetylsalicylic acid, synthesis of 489
- acid mine drainage, monitoring 228
- acid rain, consequences of 503–504
- acid-base indicators, colour changes in 194–195
- acid-base properties and reactions 350–352
- acid-base reactions 125–126
- acid-carbonate reactions 126
- acid-metal reactions 127
- acidic solutions 159
- acidity constants  $K_a$  and  $pK_a$  of weak acids 166, 172
- acids
- concentration vs strength 152–158
  - determining  $K_a$  of 167–170
  - dissociation of 73–74
  - equilibrium constants for 73–74
  - in food and digestion 132
  - in orange juice 205–206
  - reactions of 125–128
  - use by indigenous peoples 229–230
- activation energy 32
- addition polymerisation 369, 371–381
- modelling 379–381
- addition polymers 375–376
- monomers made from, and uses of 379
- addition reactions by unsaturated hydrocarbons 296–298
- alanylglycine peptide 395–396
- alcohol concentration, measuring by titration 216–218
- alcohol reaction with sodium 450
- alcohols 264–272
- combustion of 316–322
  - dehydration of 322
  - distinguishing types of 325
  - naming and drawing 265–266
  - oxidation of 323–327
  - production of 327–332
  - properties of 268–272
  - types of 266–268
- aldehydes 273–275
- naming and drawing 273–274
  - properties 274–275
- algal blooms in waterways 406–407
- alicyclic compounds 241
- aliphatic compounds 240
- alkaline solutions 159
- alkanes 240, 242–246
- combustion of 299–300
  - drawing 245
  - melting and boiling points 257
  - naming 243–245
  - properties of 256–258
  - uses of 257–258
- alkanes and alkenes, comparing reactivities of 302–303
- alkenes 240, 246–248
- alcohol production from 328
  - drawing 248
  - naming 247
  - uses of 257–258
- alkoxide anion (RO<sup>-</sup>) 450
- alkynes 240, 249–250
- naming and drawing 249
- alpha-amino acids 394–395
- Alphitonia excelsa* (soap tree), use by indigenous peoples 229
- aluminium, accumulation in body 435
- amide links 395
- amides 283–284
- naming 284
  - properties of 284
- amines 121, 280–283
- drawing 282
  - naming 281–282
  - properties of 283
- amino acids 280, 350, 394–396
- three-letter abbreviations of 396
- amino functional group 280–283
- ammonia
- industrial production of 495–496
  - reaction with an acid 126
- ammonia dilemma 136
- ammonia production 43
- flow chart for 362
- ammonium molybdate test 423
- ammonium salts 126
- amorphous packing of polymer chains 374
- amphiprotic nature of water 138
- amphiprotic salts 183–185
- ampicillin 489
- amphoteric oxides 124
- amylopectin 397
- amylose 397
- anaerobic conditions 331
- analogue devices, reading 13
- analysis techniques
- applying 227–230
  - in industry 227–228
  - in wine industry 227–228
- analytes 198
- analytical techniques 453–454
- anionic detergents 353–354
- anions
- flow chart for identifying 421
  - tests for 424
- anions in solution, identifying 419–425
- antacids 131–132
- antibiotics, structure of 489
- aromatic compounds 254–255
- aromatic hydrocarbons 240
- Arrhenius, Svante, theory of acids and bases 135–137
- aspirin, analysis using back titration 210–213
- atactic polypropylene 378
- atomic absorption spectroscopy (AAS) 434–437
- atomic mass unit (amu) 456
- atomic nucleus, chemical environment of 462–463
- atoms, energy levels in 409
- Avicennia marina* (grey (white) mangrove), as sting treatment 230
- azoxyglycosides, toxins in cycads 91
- back titrations 208–210
- in analysis of aspirin 210–213
- bakelite, composition of 273
- baking powder 132
- balance, keeping biological systems in 221–226
- ball and stick models 239–240
- base peak of mass spectrum 456
- bases
- concentration vs strength 152–158
  - dissociation constants for 74, 173–178
  - use by indigenous peoples 229–230
- Becker, Johann, and phlogiston 2
- Beer-Lambert Law 63–64, 475–476
- Beilschmiedia bancroftii* (yellow walnut), toxin removal from 92
- benzene, hazards to health of 293
- benzene (C<sub>6</sub>H<sub>6</sub>) 254–255
- benzene rings 240
- Bhopal chemical spill disaster 504–505
- biodegradability of polymers 384
- biodegradable synthetic plastics 508–509
- biodiesel 333, 334–336
- bioethanol 336
- biofuels 333–336
- compared with fossil fuels 336
- biological catalysts 336
- biological systems
- buffering in 225–226
  - keeping in balance 221–226
- biopolymers 508, 509
- blank titrations 426
- blood, buffering of 225–226
- body exposure to organic compounds 293

- boiling points  
 of alcohols 268–270  
 of organic compounds 288
- Bowenia spectabilis* (toxic cycad) 91–92
- branched chains 243
- branching of polymers 382
- Brisbane River, pollution by firefighting foam 406
- Brønsted-Lowry theory of acids 137–138
- buffer capacity 222
- buffering, in the environment 224–225
- buffers 221–224  
 effect of 222–224
- burettes 191
- butane, use of 306
- butane (C<sub>4</sub>H<sub>8</sub>) 242  
 use of 306
- 
- cadmium  
 absorbance of known concentrations of 441  
 testing for in water supplies 97
- Calamus australis* (lawyer cane), leaching toxins from 92
- calcium carbonate 35
- calcium carbonate reaction to hydrochloric acid 126
- percentage yield of carbon dioxide in 499–500
- calorimetric experiments 317
- Capparis lasiantha* (*Nippan*), as sting and bite treatment 230
- carbamide (urea) 280
- carbon  
 bonding in 239–242  
 isotopic composition of 458
- carbon capture, post-combustion 308
- carbon dioxide  
 determining percentage yield of 499–500  
 emission during combustion 308–309  
 increase in atmosphere 306  
 release during baking 126, 132  
 solubility 308
- carbon monoxide and human health 300
- carbon sequestration 308–309
- carbonate ions, testing for 421–422
- carbonyl compounds 273–275
- carboxylate ions 346
- carboxylic acids 276–280, 277–279, 349  
 boiling point of 277  
 monoprotic nature of 278–279  
 solubility of 278
- Carpobrotus glauscescens* (pig face), as sting treatment 229
- catalysts  
 effect of addition on equilibrium 49  
 in Haber process 496  
 catalysts in contact process 494–495
- catalytic cracking 304–305, 369
- cationic detergents 353–354
- cations  
 flow chart for identifying 414  
 identifying unknown 415–416  
 identifying using precipitation reactions 412–414
- cations in solution, identification 409–419
- cellulose 330  
 as source of chemicals 507–508
- chain isomers 253–254
- chain length of polymers 382
- change in enthalpy  $\Delta H$  for a chemical reaction 128
- chemical changes 28–29
- chemical environment of atomic nucleus 462–463
- chemical shift in mass spectroscopy 463
- chemical spills  
 consequences of 504–505  
 pollution due to 406
- chemical synthesis  
 and environmental issues 503–505  
 flow charts for 362–364
- chemical systems 28  
 equilibrium in 34–36
- chemical waste, disposal of 294
- chromophores 475, 476
- citric acid 277, 349
- clay, use by indigenous people and in modern medicine 230
- closed systems 38
- cocky apple (*Planchonia careya*), toxins in 91
- colourimetry 438–440  
 determining an equilibrium constant with 63–66  
 measuring concentration of copper(II) sulfate using 439–440  
 quantitative analysis using 438
- column graphs 20
- combustion of alcohols, enthalpy of 316–322
- combustion experiments, analysing enthalpy of 319–320
- combustion reactions  
 by unsaturated hydrocarbons 295–296  
 spontaneous 27
- common ion effect 107–110, 207  
 on solubility of salts 108
- complementary colours 438
- complexation reactions 417–418
- compounds in a homologous series, properties of 257
- concentration, effect on equilibrium of changes in 41–42
- concentration and partial pressure, changes to 40–42
- concentration vs strength of acids and bases 152–158
- concentration vs time, graphing 37–38
- condensation polymerisation 369  
 modelling 392
- condensation polymers 387–393
- condensation reactions 344
- condensed formula 241
- conductivity graphs 206–208
- conjugate acid-base pairs, strength of 181–183
- conjugate pairs and mirror companions 145–146
- contact process 491  
 conditions used in 493–495
- convergent pathways in reactions 491–492
- convergent sequence of reactions 491–492
- copolymers 380–381, 388
- copper(II) sulfate, using colourimetry to measure concentration of 439–440
- coral reefs, damage to 307
- Corey, E. J., and retrosynthetic analysis 490
- corkwood tree (*Duboisia myoporoides*) 229
- cross-linked polymers, making 383–384
- cross-linking of polymers 383
- crude oil 304  
 mining and transporting 305–306
- crude oil and synthetic polymers 369
- crystalline packing of polymer chains 374
- crystallinity of polymers 382
- crystallisation, water of 83–85
- cycads, toxins in 91–92
- cyclic hydrocarbons 241
- 
- Dacron 388
- Davy, Humphry, and acidity 135
- decane, use of 257
- Deepwater Horizon offshore drilling rig 305
- dehydration of alcohols 322
- density, identifying plastics by 385–386
- depth study plan 11
- detergents  
 action in hard water 359  
 action and use of 358  
 cleaning method of 357  
 structure 353–355  
 synthesis of 354–355
- diesel fuel 335
- digestion of cellulose  
 by cellulose enzymes 507  
 with strong acid 507
- digital devices, reading 13
- dilution, effect on pH and pOH 164–165
- dipeptides 395

disaccharides 330  
dissociation of acids and bases 73–74  
dissociation constant  $K_a$  166  
    of polyprotic acids 171  
dissociation constant  $K_b$  values for weak  
    bases 174  
dissociation constants, applying for acids  
    165–173  
dissociation constants for bases 173–178  
distillation column in oil refinery 304  
DNA bases 349–350  
*Dodonaea viscoa* (hop-bush), as sting  
    treatment 229  
*Duboisia myoporoides* (corkwood tree) 229  
dynamic equilibrium 34

E10 fuel 334  
effects on body of organic compounds  
    293  
electromagnetic spectrum and  
    spectroscopy techniques 453–454  
electron cloud shielding of proton 462  
emulsifiers and emulsions 353  
end point-indicators, identifying 194–195  
endothermic reactions 46–47  
energy levels in atoms 409  
energy produced by fuels, comparing  
    320–321  
enhanced greenhouse effect 307–308  
enthalpy 25  
    measuring 129–131  
enthalpy change  $\Delta H$  in chemical reaction  
    128  
enthalpy of combustion of alcohols  
    316–320  
enthalpy of combustion experiments,  
    analysing 319–320  
enthalpy of neutralisation 128–131  
entropy 25  
environment, buffering in 224–225  
environmental issues with chemical  
    synthesis 503–505  
environmental monitoring, reasons for  
    405–407  
environmental triggers 509  
enzymes in fermentation 330  
equilibrium  
    determining whether reaction has  
        reached 68  
    effect of adding catalyst 49  
    effect of changes to concentration on  
        41–42  
    and graphing 37–39  
    modelling 35–36  
equilibrium in chemical systems 34–36  
equilibrium concentration  
    determining by ICE method 66–67  
    using  $K_{eq}$  to calculate 69

equilibrium constant, effect of  
    temperature on 71–72  
equilibrium constant  $K$  54  
    magnitude of 58–59  
equilibrium constant  $K_a$  for weak acids 74  
equilibrium constant  $K_b$  for bases 74, 173  
    determining 174–176  
equilibrium constant  $K_b$  for a weak base,  
    determining 176–178  
equilibrium constant  $K_c$  in terms of  
    concentration 76  
equilibrium constant  $K_{eq}$ , application to  
    differing types of chemical reactions  
    72–77  
equilibrium constant  $K_p$  in terms of  
    pressure 75  
equilibrium constants  
    measuring 61–67  
    units for 59–60  
    uses of 67–69  
equilibrium expression, calculating 54–56  
errors, in gravimetric analysis 432  
esters  
    formulae and properties of common  
        344  
    naming 343  
    preparation reaction 344  
    preparing simple 347–348  
    properties of 343–344  
    purifying 345–346  
    structure of 342–343  
ethane ( $C_2H_6$ ) 242  
    use of 306  
ethanoic (acetic) acid 277, 279  
    mass spectrum of 455–456  
ethanol  
     $^{13}C$  NMR spectrum of 467  
    production of 334  
    uses of 264, 306  
ethanol production 297  
ethene ( $C_2H_4$ ) 246  
    use of 258, 305  
ethyl alcohol, uses of 264  
ethyl butanoate 343  
    convergent synthesis of 492  
ethyl ethanoate 344  
    produced by multistep pathway 491  
ethylene (ethene), synthetic polymers  
    from 369, 371–372, 375–376  
ethyne ( $C_2H_2$ ) 249  
eutrophication of bodies of water 407  
excess reagent (reactant)  
    calculating 496–497  
    in contact process 494  
exothermic reactions 46–47, 494  
expanded formula 241  
exposure to organic compounds 293  
    prevention of 293–294  
Exxon Valdez oil spill 305

Fajan's method 428–429  
fatty acids 334–335  
feedstock 258  
fermentation  
    conditions for 330–331  
    measuring rate of 331–332  
    production of alcohol by 329–333  
fertilisers  
    made using neutralisation reaction 133  
    pollution due to 406–407  
fingerprint region of spectra 471  
flame colours of some elements 410  
flame tests 409–411  
food flavours from esters 342  
formaldehyde (methanal) 273  
formic (methanoic) acid 276–277  
forward reactions 29  
fossil fuels 333  
    compared with biofuels 336  
fractional distillation 304–305  
fragmentation patterns in mass  
    spectroscopy 455–456  
fructose 330, 396  
fuels, comparing energy produced by  
    320–321  
fuels (non-fossil) from different sources  
    333–337  
fumaric acid 349  
fume cupboard 294  
functional group isomers 274  
functional groups 263–264  
    chemical tests for 448–452

galactose 396  
gas chromatography (GC) 227  
gaseous system, changing volume at  
    equilibrium 44–45  
geckos and Teflon 376  
Gibbs free energy ( $\Delta G$ ) 26–27  
glassware, using 192–194  
glucose 330  
    polymers of 396–397  
glycerol 335–336  
glycine 394  
glycogen 397  
goats foot (*Ipomea pes-caprae*), as sting  
    treatment 230  
graft polymers 509  
graphing and equilibrium 37–39  
graphs 16–17  
    of conductivity 206–208  
    identifying system changes on 49  
    of pH in titrations 203–204  
gravimetric analysis 431–432  
Great Barrier Reef  
    damage to 307  
    Marine Park oil spill 306  
green chemistry 505  
green polymers, case study 506–509



- greenhouse effect 306–308
- grey (white) mangrove (*Avicennia marina*), as sting treatment 230
- 
- Haber process, for production of nitrogen-based fertilisers 495–496
- halides (Cl, Br and I) ions, testing for 422
- haloalkenes 250
- halogen atoms 240
- halogenated organic compounds 250–253  
production of alcohol from 328–329
- halogenation 297
- halogens, substitution with 300–301
- halogenated organic compounds
- hard water 354  
action of soaps and detergents in 359
- hazardous organic compounds 291
- heat of reaction 494
- heating mantles 345
- heavy metals accumulation in body 434
- high-density polyethylene (HDPE) 372–373, 375
- high-impact polystyrene 380
- high-resolution  $^1\text{H}$  NMR spectroscopy 465, 466
- homologous series  
alkanes as 243  
properties of compounds in 257
- hop-bush (*Dodonaea viscosa*), as sting treatment 229
- hydrangea flower colours 133
- hydrocarbon structures, modelling 253
- hydrocarbons  
implications of obtaining and using 303–311  
types of 240–241
- hydrogen, isotopic composition of 458
- hydrogen bonding 83
- hydrogen gas, as reaction product 127
- hydrogen halides (HX)  
addition of 297  
substitution with 322–323
- hydrogenation of unsaturated hydrocarbons 296
- hydrophilic substances 353
- hydroxide ions, testing for 421–422
- hypotheses 3  
formulating 8–9
- 
- ICE method of determining equilibrium concentrations 66–67
- immiscible substances 345–346
- incomplete combustion 300
- indicators  
choosing 200–202  
used in Fajan's method 428
- indigenous peoples, use of acids and bases by 229–230
- industrial spills, treatment of 134
- infrared (IR) spectroscopy  
data output 453  
principles of 469–471
- infrared spectra, interpreting 471–472
- inhibitor, Lindlar catalyst as 296
- inorganic acids, naming 120
- inorganic acids and bases, properties of common 122–125
- inorganic bases, naming 121
- Intergovernmental Panel on Climate Change (IPCC) 306
- intermediates of penicillin 489
- interpretation of results 17–18
- investigations, designing and planning 9–11
- iodide ion concentration by titration (Volhards' method) 429–430
- ion streams 456
- ion-dipole bonds 83
- ionic compounds  
dissolution of 85–86  
identifying 98–99  
solubility of 408  
structure of 82–84
- ionic product  $Q_{sp}$  106–107
- ionic substances, solubility of 96–97
- ionisation reactions 152
- ions, quantitative analysis of 425–433
- ions in solutions, identifying 407–408
- Ipomea pes-caprae* (goats foot), as sting treatment 230
- isolation, for prevention of chemical contact 293–294
- isomers 253–254
- isomers of alcohol, naming and drawing 265–266
- isotactic polypropylene 378
- isotopes and mass spectra 457–458
- IUPAC (International Union of Pure and Applied Chemistry) 119
- 
- ketone production 297
- ketones 273–275  
naming and drawing 273–274  
properties 274–275
- 
- lactic acid 277
- Lavoisier, Antoine, and acidity 135
- lawn fertiliser, measuring sulfate content of 432–433
- lawyer cane (*Calamus australis*), leaching toxins from 92
- Le Chatelier, Henri Louise  
principle of 39–49  
use of his principle 107–108
- leaching of salts 92–93
- lead  
absorbance of 437  
testing for in water supplies 97
- lead poisoning 434
- lead(II) iodide, determining  $K_{sp}$  for 111–112
- Lewis, Gilbert, defining acids and bases 138–139
- ligands 417
- light, wavelength and energy 409
- light detector 435
- limit of reading 13
- limiting reactants (reagents), calculating 496–497
- Lindlar catalyst 296
- linear pathways in reactions 491
- linear regression tool 16–17
- linear sequence of reactions 491
- lipase as catalyst in biodiesel production 336
- liquid petroleum gas (LPG) 257
- literature reviews 7–8
- litmus, extraction of 122
- logbooks 6
- long chain alkanes, modelling cracking of 370
- low-density polyethylene (LDPE) 372–373, 375
- low-resolution  $^1\text{H}$  NMR spectroscopy 464–467  
intensity of signal in 465  
number and location of peaks in 465
- 
- macromolecules 369
- magnesium ammonia test 423
- magnesium metal reaction with dilute hydrochloric acid 127
- magnesium reaction with oxygen, percentage yield of magnesium oxide in 500–501
- main chain 243–244
- main (parent) chain 244
- malic acid 349
- margarine production 296
- Markovnikoff's rule 297–298
- mass spectra  
interpreting 456–459  
and isotopes 457–458
- mass spectroscopy 454–459  
data output 453  
principles of 455–456
- mass spectroscopy techniques, combining 480
- matching structures, identifying 472–474
- meniscus 191
- mercury  
absorbance of 436  
concentration in fish 436–437
- methanal (COH) 273
- methane ( $\text{CH}_4$ ) 242  
use of 257, 306
- methanoic (formic) acid 276–277

- methanol production, flow charts for 363–364
- micelles 357
- mining industry, analysis techniques in 228
- mirror companions and conjugate pairs 145–146
- models in chemistry 4
- Mohr's method 425–426
- molar solubility, determining  $K_{sp}$  using 102–103
- molarity (M) 152
- mole fraction 75
- molecular formula 241
- molecular ions 455
- molecular weights of alkanes and alcohols 269
- monochromator 435
- monomers 369
- monosaccharides 330, 396
- multistep processes in reactions 491
- multistep reactions 490
- 
- $n + 1$  rule 466
- natural aquatic systems, buffering in 224–225
- natural gas, mining and transportation of 305–306
- natural indicators, preparing and using 122–124
- natural polymers 369, 393–397
- neighbouring atoms, in  $^1\text{H}$  NMR spectra 466–467
- neutral solutions 159
- neutralisation 125
  - enthalpy of 128–131
  - and industry 132–134
  - modelling 180–181
- neutralisation reactions 128–134, 178–185
  - applications of 131–134
- Nipon* (*Capparis lasiantha*), as sting and bite treatment 230
- nitrogen dioxide 44
- nitrogen-based fertilisers, Haber process 495–496
- Nomenclature of Inorganic Chemistry* (the Red Book) 119
- non-equilibrium systems 25–27
- non-fossil fuels from different sources 333–337
- non-ionic detergents 353–354
- nonane, use of 257
- nuclear magnetic resonance (NMR) spectroscopy 461–468
  - data output 453
  - interpreting spectra 464
  - principles of 461–462
- nylon 389–391
- 
- octane, use of 257, 305, 306
- octane rating 334
- oil refinery, distillation column in 304
- open systems 28
- orange juice, acid content in 205–206
- organic acids and bases 349–351
  - properties of 351–352
- organic chemicals, risks related to physical properties 292–293
- organic compounds 239
  - boiling points of 288
  - disposal of 294
  - distinguishing between different classes of 449–452
  - halogenated 250–253
  - hazardous 290–295
  - multistep synthesis of 361
  - prevention of exposure to 293–294
  - some classes of 448–449
  - tests to determine classes of 450
- organic compounds and reactions, flow chart and summary of 360–361
- organic molecules
  - common fragmentations in mass spectrum 457
  - typical analysis techniques for 480
- organic substances, safe use of 290–295
- oxidation of alcohols 323–327
- oxyacids 120
- oxygen, isotopic composition of 458
- 
- Pamelia sulcate*, extraction of litmus from 122
- paracetamol synthesis 497
- parallax error in readings 191
- parent molecular ions 455
- partial pressure and concentration, changes to 40–42
- partial pressures 75
- Pascal's triangle 466, 467
- patterns, identifying 15–17
- peanut tree (*Sterculia quadrifida*), as sting treatment 229
- penicillin, synthesis of 489
- pentane, use of 257
- peptide links 389, 395
- percentage ionisation 170–171
- percentage yield, calculating 498
- pH
  - calculating 150–151
  - of common substances 148
  - effect of dilution on 164–165
  - and hydrogen ion concentration 147
  - measuring 147–150
  - of monoprotic acids 157
  - of polyprotic acids 157
  - relationship with pOH 102–103
  - of salts from reaction between acids and bases 183
  - of solutions of strong and weak acids and bases 154–156
- pH graphs for titration 203–204
- pH (hydrogen power) scale 146–152
- pH of organic acids 350
- pH of solutions, using  $K_w$  to calculate 159–161
- pharmaceutical industry, chemical analysis in 228
- phenolic compounds, typical absorbance wavelengths for 477
- phlogiston theory 2
- phosphate ions, testing for 423
- phosphorus, absorbance of known concentrations 442
- photosynthesis reactions 27
- physical changes 28
- pig face (*Carpobrotus glauscescens*), as sting treatment 229
- pipettes 192
- $pK_a$ , understanding 172
- Planchonia careya* (cocky apple), toxins in 91
- plasticisers 377
- plastics 368
  - escalating problems with use 368
  - identification codes for 309–310
  - identifying by density 385–386
- pOH
  - defining and calculating 162–165
  - effect of dilution on 164–165
- poisoning by organic compounds 293
- polyamides 280, 389–392
- polyesters 387–389
- polyethylene 371–372, 374
- polyethylene terephthalate (PET) 388
  - recyclability of 388
- poly(lactic acid) 387–388
- polymer chains, crystalline and amorphous packing of 374
- polymerisation 298, 369
- polymers 368
  - green 506–509
  - naming 376
  - natural 393–397
  - pollution due to 309–311
  - relating properties, uses and structure of 381–386
  - stability and biodegradability of 384
- polypeptides 395
- polypropylene (PP) 378–379
- polyprotic acids 157
  - $K_a$  of 171–172
- polysaccharides 330
- polystyrene (PS) 377–378
- polytetrafluoroethylene (PTFE) 376
- 'polyunsaturated' margarine and oils 296
- poly(vinyl chloride) (PVC) 377
- positional isomers 253

post-combustion carbon capture 308  
potassium chloride, solubility curve for 89–90  
potassium permanganate, standardising 214–216  
potentiometric titration, to determine purity of silver, gold and palladium 228  
precipitates formed between cations and anions 420  
precipitation, predicting 95–96  
precipitation reactions 94–95  
  identifying cations with 412–428  
precipitation titrations 425–430  
precision 13  
pressure  
  in contact process 494  
  effect on volume of change in 42–44  
  expressing equilibrium constants for gaseous systems in terms of 75  
  in Haber process 496  
primary alcohols 266  
  oxidation of 323–324  
primary amides 283  
primary amines 281  
primary haloalkanes 328  
primary source investigations 5, 9–10, 19  
primary standard solutions 195–196  
  making 196–197  
propane (C<sub>3</sub>H<sub>8</sub>) (LPG) 242, 257  
propene (C<sub>3</sub>H<sub>6</sub>) 246  
  structure of 378  
  use of 258, 305  
protein chain folding 394  
proteins 280, 393–394  
proton shifts values, typical 464  
purity of final product, determining 501–502

---

quantitative analysis  
  using AAS 436  
  using colourimetry 438  
questions, posing 8–9

---

radicals 455  
random errors 15  
reactants in synthesis reactions 490  
reaction pathways, choosing 490–492  
reaction quotient (*Q*) 56–58  
reaction rate vs time, graphing 37  
reactions, yields of 492–502  
recycling of plastics 309–311  
recycling symbol 309  
Red Book 119  
redox titrations 214–220  
reference lists 21  
reflux process 345  
*Regina* tanker oil spill 306  
relationships, identifying 15–17  
repeat measurements, taking 14

reports, writing 18–21  
resolution 13  
results, interpreting 17–18  
retrosynthetic analysis 490  
reverse reactions 29  
reversibility, predicting 32–33  
reversible reactions 29–33  
risk assessment 12

---

Safety Data Sheet (SDS) 290  
  and chemical labelling 292  
salicylic acid 489  
'salting out' 355  
salts, amphiprotic 183–185  
saponification reaction 354  
'saturated fats' 296  
saturated fatty acids 334–335  
saturated hydrocarbon reactions 299–303  
saturated solutions 87  
scatter plots (graphs) 16, 20  
scientific investigations *see* investigations  
scientific method 3  
scouring of fabrics 133  
scum 359  
sea shells, composition of 35  
secondary alcohols 267  
  oxidation of 324–325  
secondary amides 283  
secondary amines 281  
secondary haloalkanes 328  
secondary source investigations 5, 9–10, 20  
self-ionisation constant (*K<sub>w</sub>*) 159  
self-ionisation of water 158–161  
separating funnels 345–346  
shells, composition of 35  
shielding of proton by electron cloud 462  
side groups of polymers 383  
significant figures in calculations 15  
silver bromide 422  
silver chloride precipitation 94–95  
silver iodide 422  
silver salts, *K<sub>sp</sub>* values of 427  
simple esters, preparing 347–348  
skeletal structure 241  
soap  
  as by-product of biodiesel production 336  
  making 355–357  
soap tree (*Alphitonia excelsa*), medicinal use by indigenous peoples 229  
soaps 352–355  
  action in hard water 359  
  action and use of 358  
  cleaning method of 357  
  structure 353–355  
  synthesis of 354–355  
sodium, alcohol reaction with 450  
sodium chloride solution process in water 86

solubility 87  
  of alcohols 270–272  
  determining using *K<sub>sp</sub>* 103–106  
  of esters 343  
  of ionic compounds 408  
solubility curves for salts 87–88  
solubility data, applying 97–98  
solubility equilibria 72–73  
solubility equilibrium 100–102  
solubility product *K<sub>sp</sub>* 73, 100–101  
  determined using molar solubility 102–103  
  determining solubility using 103–106  
solubility rules 94–100  
solution and solvent in mass spectroscopy 463  
soot 300  
Sorensen, Soren, and pH scale 146  
specific heat capacity (*c*) 316  
  of water 129  
spectator ions 72  
space-filling models 239–240  
spin-spin coupling 466  
splitting pattern in high-resolution NMR 467  
spontaneous reactions 25–26  
stability of polymers 384  
standard deviation 14  
standard enthalpy change  $\Delta H_{\theta}$  129  
standard enthalpy of neutralisation 129  
starch 330  
starch polymer 397  
static equilibrium 29  
*Sterculia quadrifida* (peanut tree), as sting treatment 229  
stereoregular polymers 379  
stings, treating with plants 229–230  
straight-chain alkanes 242–243  
strength of acids and bases 152–153  
strength vs concentration of acids and bases 152–158  
  modelling 156  
strong acids 152–153  
strong bases 153  
strong polyprotic acids, *K<sub>a1</sub>* of 171  
structural formula 241  
styrene 378  
substituents 244  
substitution with hydrogen halides (HX) 322–323  
substitution reactions 300–301  
succinic acid 349  
sucrose 330  
sugars, types of 329–330  
sulfate content of lawn fertiliser, measuring 432–433  
sulfate ions, testing for 423  
sulfur dioxide content of wine, determining 219–220



- sulfuric acid, produced by contact process 491, 493–495
- sunscreens, synthesis of 488
- surface tension of water 352–353
- surfactants 352–353
- syndiotactic polypropylene 378
- synthesis reactions  
designing 490–492  
uses of 488–489
- synthetic plastics, biodegradable 508–509
- synthetic polymers 368, 369–371
- synthetic rubber 380
- system changes, identifying on a graph 49
- 
- Teflon  
polymer 376  
strength of 377
- temperature  
in contact process 494  
effect on equilibrium constant 71–72  
in Haber process 495–496
- temperature at equilibrium, effect of  
changes to 45–48
- tertiary alcohols 267  
oxidation of 325
- tertiary amides 283
- tertiary amines 281
- tertiary haloalkanes 328
- Terylene 388
- tetramethylsilane (TMS) 463
- theoretical yield, calculating 496–497
- thermal cracking 305, 369
- thermoplastic polymers 369
- thermosetting polymers 369
- $^{13}\text{C}$  NMR carbon shifts values, typical 464
- $^{13}\text{C}$  NMR spectroscopy 467–468  
number and location of peaks in 467
- time vs concentration, graphing 37–38
- time vs reaction rate, graphing 37
- titrants 198
- titratable acidity 227
- titration 190–191  
potentiometric 228
- titration curves, using 203–204
- titration types, indicators used for 200
- titrations  
back 208–210  
performing 201–202  
precipitation 425–430  
redox 214–220  
to measure concentration of alcohol 216–218
- toothpaste 132
- toxicity of foods, removal by Indigenous peoples 91–93
- transesterification 335–336
- trends, identifying 15–17
- triglycerides 335–336
- 
- ultraviolet-visible (UV-vis) spectrophotometry  
data output 453  
determining concentrations using 478  
identifying a substance using 476  
judging wine using 477–478  
principles 475–476  
quantitative analysis in 476, 478
- uncertainties, estimating 13–15
- universal indicator 148
- unknown cations, identifying 415–416
- unpalatable substances 91
- unsaturated fatty acids 334–335
- unsaturated hydrocarbon reactions 295–298  
modelling 298–299, 301
- unsaturated solutions 87
- urea (carbamide) 280
- 
- vaporisation of AAS test specimens 435
- volatile compounds 292
- Volhard's method 427–428
- volume, effect on pressure of change in 42–45
- volumetric analysis 190–195  
performing 198–203
- volumetric flasks 191
- 
- wastewater from mines, treatment of 133–134
- water  
addition of 297  
precipitation reactions and solubility data in 407–408  
self-ionisation of 158–161  
structure of 83–84
- water of crystallisation 83–85
- water quality testing 408–408
- wavenumber ( $\text{cm}^{-1}$ ) 470
- weak acids 73, 152–153  
determining  $K_a$  of 168–170
- weak bases 153  
naming 121
- weak polyprotic acids,  $K_a$  values of 171–172
- wet analysis of metals, alloys and ores 228
- white smoke demonstration 136–137
- wine  
determining sulfur dioxide content 219–220  
judging using UV-vis spectrophotometry 477–478
- wine industry, analysis techniques in 227–228
- 
- yeast in fermentation 329
- yellow walnut (*Beilschmiedia bancroftii*),  
toxin removal from 92
- yield, maximising 492–493
- yields of reactions 492–502
- 
- zeolites (aluminosilicates) 304, 369
- Ziegler-Natta catalysts in polypropylene  
manufacture 378
- Ziegler-Natta process for HDPE  
production 372

