

NAME:

ALGORITHMICS UNIT 3 & 4**CHES Trial Exam 2: 2023**

Reading Time: 15 minutes
Writing time: 120 minutes (2 hours)

QUESTION AND ANSWER BOOK

<i>Section</i>	<i>Number of questions</i>	<i>Number of questions to be answered</i>	<i>Number of marks</i>
A	20	20	20
B	10	10	80

- Students are permitted to bring into the examination room: pens, pencils, highlighters, erasers, sharpeners, rulers and one scientific calculator.
- Students are NOT permitted to bring into the examination room: blank sheets of paper and/or correction fluid/tape

Materials supplied

- Question and answer book of ?? pages
- Answer sheet for multiple-choice questions

Instructions

- Write your student number in the space provided above on this page.
- Check that your name and student number as printed on your answer sheet for multiple-choice questions are correct, and sign your name in the space provided to verify this.
- All written responses must be in English, point form is preferred.

Students are NOT permitted to bring mobile phones and/or any other unauthorised electronic devices into the test room.

IMPORTANT NOTE: The VCAA Exam will include the Master Theorem in this form.

- the Master Theorem for solving recurrence relations of the form:

$$T(n) = \begin{cases} a \cdot T\left(\frac{n}{b}\right) + kn^c & \text{if } n > 1 \\ d & \text{if } n = 1 \end{cases}$$

where $a > 0, b > 1, c \geq 0, d \geq 0, k > 0$

and its solution: $T(n) = \begin{cases} O(n^c) & \text{if } a < b^c \\ O(n^c \log(n)) & \text{if } a = b^c \\ O(n^{\log_b(a)}) & \text{if } a > b^c \end{cases}$

The VCAA form of Master Theorem is equivalent to the form of Master Theorem taught in our class by consideration of log laws.

$$\log_b a = c \Leftrightarrow a = b^c \Leftrightarrow \frac{a}{b^c} = 1$$

$$\log_b a < c \Leftrightarrow a < b^c \Leftrightarrow \frac{a}{b^c} < 1$$

$$\log_b a > c \Leftrightarrow a > b^c \Leftrightarrow \frac{a}{b^c} > 1$$

$$T(n) = aT\left(\frac{n}{b}\right) + f(n^k)$$

- $\frac{a}{b^k} < 1$ then $O(n^k)$
- $\frac{a}{b^k} = 1$ then $O(n^k \log_b n)$
- $\frac{a}{b^k} > 1$ then $O(n^{\log_b a})$

SECTION A – Multiple Choice – select one option only

Question 1

The Breadth First Search algorithm is run on the following graph. One possible order of visiting the nodes of the following graph is:

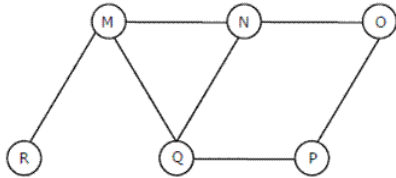

- A. MNOPQR
- B. NQMPOR
- C. QMNPRO
- D. QMNPOR

Question 2

When Prim's is executed on the following graph, starting at any vertex:

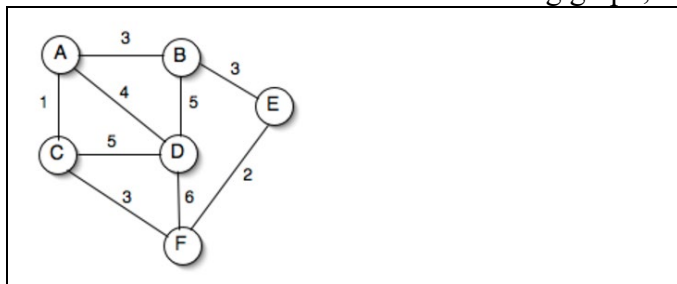

The Edges (in no particular order) included and the weight of the MST are:

- A. $E=\{AC,AB,BE,EF,AD\}$ weight=13
- B. $E=\{AC,AD,CF, EF,BE\}$ weight=13
- C. $E=\{AC,AB,BE,EF,BD\}$ weight=14
- D. Both $E=\{AC,AB,BE,EF,AD\}$ weight=13 and $E=\{AC,AD,CF, EF,BE\}$ weight=13

Question 3

Which of the following sequences are topological sorts for the directed acyclic graph below?

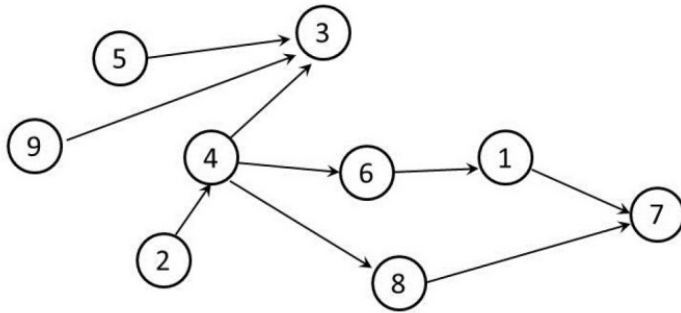

- A. 9, 2, 5, 4, 3, 8, 1, 6, 7
- B. 9, 2, 5, 4, 8, 5, 1, 7, 3
- C. 9, 2, 5, 3, 4, 6, 8, 1, 7
- D. 2, 9, 5, 4, 6, 3, 8, 1, 7

Question 4

Which of the following sorting algorithms does not have a worst case running time of $O(n^2)$

- A. Insertion sort
- B. Merge sort
- C. Quick sort
- D. Bubble sort

Question 5

```
function quiz(i)
// Input integer 'i'
    if (i > 1)then
        quiz(i / 2)
        quiz(i / 2)
    end if
    print("*")
end function
```

How many asterisks are printed by the function call quiz(5)?

- A. 4
- B. 7
- C. 8
- D. Some other number

Question 6

Consider the following operations that are performed on an empty queue "Q":

- Enqueue(Q,"ron")
- Dequeue(Q)
- Enqueue(Q,"harry")
- Enqueue(Q,"hermoine")
- Enqueue(Q,"snape")
- Dequeue(Q)

The contents of the queue Q after these operation is:

- A. hermoine, harry
- B. hermoine, snape
- C. harry, hermoine, snape
- D. ron, harry

Question 7

When converted to a spanning tree, the graph shown will resemble which of the following?

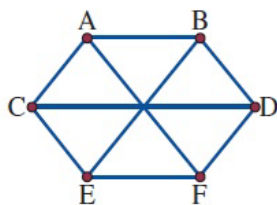

A		C	
B		D	

Question 8

The definition of the recursive function $T(n)$ where n is in the set of Natural numbers is shown below:

$$T(n) = T(n-1) - 1, \text{ where } T(0) = 20$$

The value of $T(6)$ is:

- A. 14
- B. 13
- C. 10
- D. 15

Question 9

Which of the following problems is classified as being tractable?

- A. Travelling Salesman Problem (TSP)
- B. Finding a Spanning Tree in a simple graph
- C. Knapsack 0/1 Problem
- D. Hamiltonian Path Problem

Question 10

List refers to a list. If there are k items in the list, roughly how many iterations are there for the following pseudocode?

```
sum:=0
for each value in List do
    sum:=sum+value
enddo
```

- A. k
- B. $k/2$
- C. 1
- D. 2

Question 11

The Transitive Closure matrix below matches which graph?

	A	B	C	D
A	1	0	0	0
B	1	1	0	0
C	1	1	1	0
D	1	1	0	1

Select one:

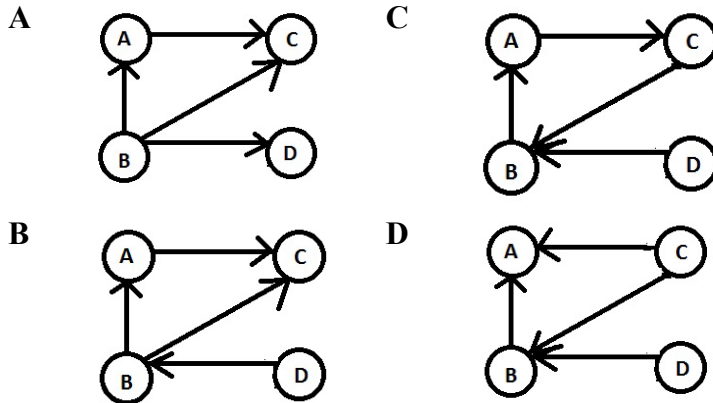

Question 12

If $T(n)$ is a function that defines the time complexity of an algorithm based on the size of the input n :

$$T(0)=3, T(n)=2T(n-1), \text{ when } n>0$$

Then the equivalent function expression for $T(n)$ is:

- A. $T(n)=3^n$
- B. $T(n)=3(2^n)$
- C. $T(n)=2^n+3$
- D. $T(n)=3(2^{(n-3)})$

Question 13

Which of the following best describes the position of Strong AI?

- A. Having a mind is a matter of having the right outputs
- B. The principal value of computers is that they are powerful tools for studying the mind
- C. Computers cannot be minds.
- D. An appropriately programmed computer is a mind, in the sense that it can understand

Question 14

What is the output of the perceptron activation function, given the inputs of x_1, x_2, x_3 with corresponding weights w_1, w_2, w_3 respectively in the table shown and a bias value of 5?

	1	2	3
x	0	1	1
w	3	2	4

- A. 1
- B. 0
- C. 6
- D. 5

Question 15

Dijkstra's algorithm on the following graph from node A, explores the nodes in order:

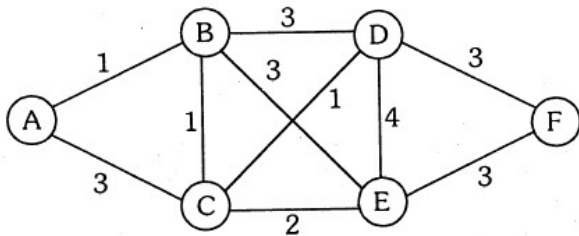

- A. A,B,C,D,E,F
- B. A,C,B,E,D,F
- C. A,B,C,E,D,F
- D. A,C,B,E,D,F

Question 16

The approach to algorithm design for optimization problems that makes direct use of the fact that the most apparent next component of a solution is part of the optimal solution is ..

- A. dynamic programming;
- B. divide and conquer;
- C. brute force;
- D. greedy;

Question 17

Master's theorem can be applied on which of the following recurrence relation?

- A. $T(n) = 2T(n/2) + 2^n$
- B. $T(n) = 0.5T(n/3) + n$
- C. $T(n) = T(n/2) + 2n^2 + 1$
- D. None of these

Question 18

A robot has been programmed to draw rectangles. It can execute the following instructions:

- **Orange** draw an orange line of length 1
- **Black** draw a black line of length 1
- **Turn** turn 90° clockwise

Besides those simple instructions the robot can also execute complex instructions by combining instructions. If A and B are instructions (either simple or complex) the robot can do:

- **A, B** first execute A and then execute B
- **$n \times (\mathbf{B})$** execute B n times

The robot must draw the following:

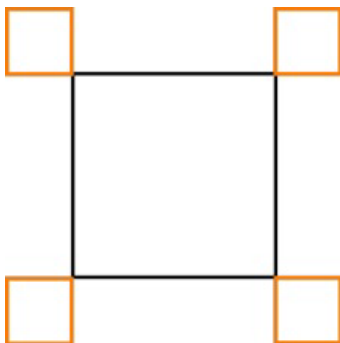

Which instructions will not create the drawing?

- A. $4x(3x\text{Black}, 3x(\text{Orange}, \text{Turn}), \text{Orange})$
- B. $4x(2x(\text{Orange}, \text{Turn}), \text{Orange}, 3x(\text{Black}), \text{Orange}, \text{Turn})$
- C. $4x(2x(\text{Orange}, \text{Turn}), 3x(\text{Black}), 2x(\text{Orange}, \text{Turn}))$
- D. $4x(\text{Black}, 3x(\text{Orange}, \text{Turn}), \text{Orange}, 2x(\text{Black}))$

Question 19

Consider the following scatterplot showing two classes of data against features X_1 and X_2 and the resulting SVM classifier which is a poor classifier.

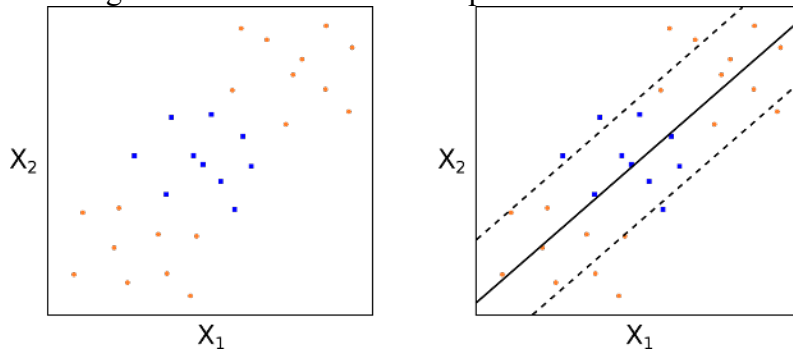

What can be done to improve the automatic classification of the two classes using machine learning?

- A. Use a perceptron neural network to learn the weights of W_1 and W_2 .
- B. Apply a linear transformation to both the original data features X_1 , X_2 .
- C. Increase the width of the maximising SVM hyperplane margin for X_1 and X_2 .
- D. Apply a quadratic transformation to both the original data features X_1 , X_2 .

Question 20

Which of the following statements about the Turing Machine is false?

- A. Lambda calculus can compute anything that any Turing Machine could possibly compute.
- B. If P equals NP, then the Traveling Salesperson Problem can be solved in polynomial time by a deterministic Turing Machine.
- C. The Turing machine is a universal model of computation: with a Turing machine we can solve any decision problem that can be solved with a Supercomputer or with a Pentium 4 running Linux.
- D. Because the Halting Problem is unsolvable, it is impossible to tell if any algorithm has an infinite loop.

SECTION B – Extended Response Questions Answer all questions in the space provided.

Question 1 (6 marks)

- a. Using Pseudocode complete the MergeSort algorithm below for sorting data. *(2 marks)*

```
Procedure Mergesort (Input A)
  Size=Length(A)
  If (Size <=1) then
    Return A
  else
    [ ]
    [ ]
    Return Merged(LeftA,RightA)
  End If
End Procedure
```

- b. Show all steps either in words or by a labelled diagram that are required to sort the following list of integers using the MergeSort Algorithm. *(2 marks)*

<table border="1"><tr><td>6</td></tr><tr><td>2</td></tr><tr><td>9</td></tr><tr><td>5</td></tr></table>	6	2	9	5	
6					
2					
9					
5					

- c. What is the design pattern that is used by the MergeSort Algorithm? Describe the general principles of this design pattern and discuss what kinds of problems lend themselves to being solved in this way. *(2 marks)*

Question 2 (12 marks)

Consider the following algorithm **MinDistance** for finding the distance between the two closest elements in an array of unsorted unique integers.

```

Function MinDistance(A[1..n])
// Input: An array A[1..n] of unique integers
// Output: The minimum distance d between two of its elements
dmin := max
for i := 1 to n-1 do
    for j:= i+1 to n do
        temp := |A[i] - A[j]| // absolute difference of values
        if temp < dmin then
            dmin = temp
            minI = i
            minJ = j
return |minI-minJ|
end function
    
```

a) What is the result of MinDistance([1,4,2])? Justify your response with a full trace of variables i,j, temp, A[i],A[j], dmin, minI, minJ in step by step execution in the table below. (2 marks)

i	j	A[i]	A[j]	temp	dmin	minI	minJ

b) Analyse the time complexity of this naive algorithm. Giving a justification for your reasoning.(2 marks)

Vivian and Daniel think that a more efficient algorithm could use a dictionary using the array element as the key and the index as the value.

Let Dmap be the label of the dictionary representation selected by Daniel and Vivian.

c) Write signature specifications for the following three operations of Dmap. (3 marks)

- Add a record to Dmap of a new array value and its index.
- Lookup the value in Dmap using the key A[k]
- Get all the keys of Dmap.

d) Using Vivian and Daniel’s idea show the contents of the dictionary “Dmap” and the instance of # Test Case 1: A = [1, 9, 6, 8] (1 mark)

Key	Value

Question 2 (continued)

- e) Using Vivian and Daniel's idea write a new algorithm in structured pseudocode for solving the MinDistance problem using the dictionary Dmap. (3 marks)

Question 3 (8 marks)

The data on ten people's yearly salaries was collected and labelled into two categories: either a person is underpaid or overpaid. In the example below, if a person is considered underpaid, then it will be labeled with red/white dots. Otherwise, if a person is considered overpaid, then it will be labeled with green/black dots.

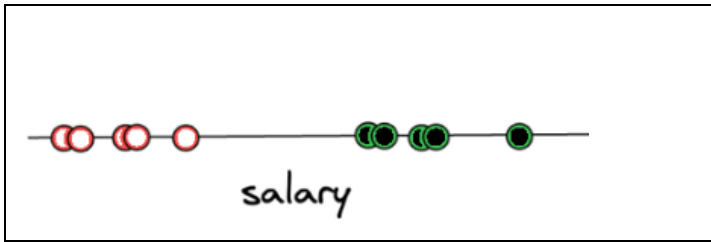

a) Indicate on the diagram above where an SVM would place the hyperplane classifier for this data. Justify your answer (2 marks)

Suppose that we want to classify one dimensional data with one feature X_1 into two classes squares and circles.

We have a set of training data that is plotted for feature X_1 as follows in the diagram below with squares in position $[0,5)$, circles in position $[5,9)$, squares in position $[9,15)$ and then only circles which extend toward the positive direction from $[17, \infty)$:

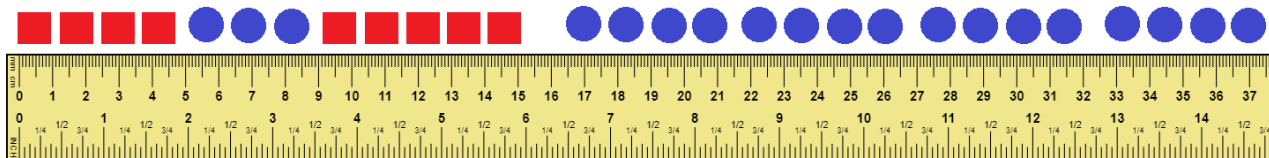

b) Can a single perceptron separate the data feature X_1 for the circles and the squares? Explain why or why not and justify your response. (2 marks)

Question 3 (continued)

c) Can a Multilayer Perceptron Neural Network classify this data? Justify your response. (2 marks)

d) Can a Support Vector Machine (SVM) machine learning algorithm classify this data? Justify your response (diagrams accepted). (2 marks)

Question 4 (8 marks)

Consider the runtime complexity statistics of the following three algorithms: L, M and N.

	Time Complexity	Space Complexity
Algorithm L	$O(n^{\sqrt{n}})$	$O(n^4)$
Algorithm M	$O(n \log n)$	$O(n \log n)$
Algorithm N	$O(10^n)$	$O(n)$

- a) If the log is base 10, evaluate the approximate time and space complexity for an input of 100 elements for each Algorithm. (2 marks)

	Time Complexity for 100 elements	Space Complexity for 100 elements
Algorithm L		
Algorithm M		
Algorithm N		

- b) Identify the Algorithms with their letter L, M, N on the curves shown below when the **time complexity** is graphed against the input size n. (1 mark)

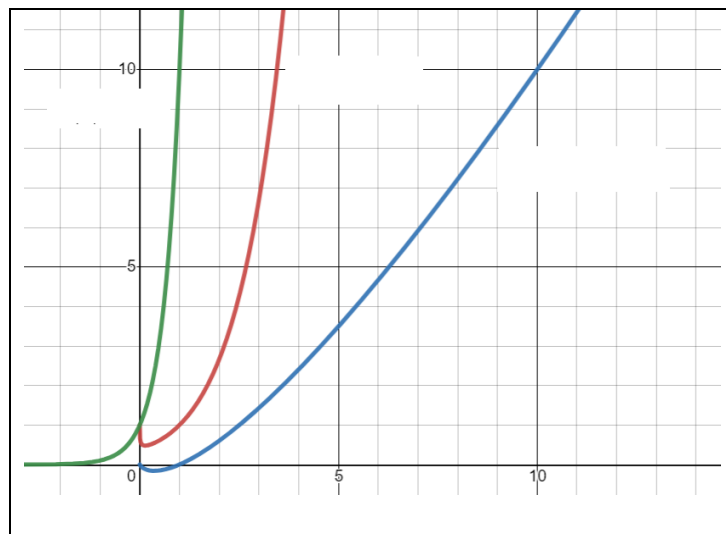

Question 4 (continued)

- c) Identify the Algorithms with their letter L, M, N on the curves when the **space complexity** is graphed against the input size n. (1 mark)

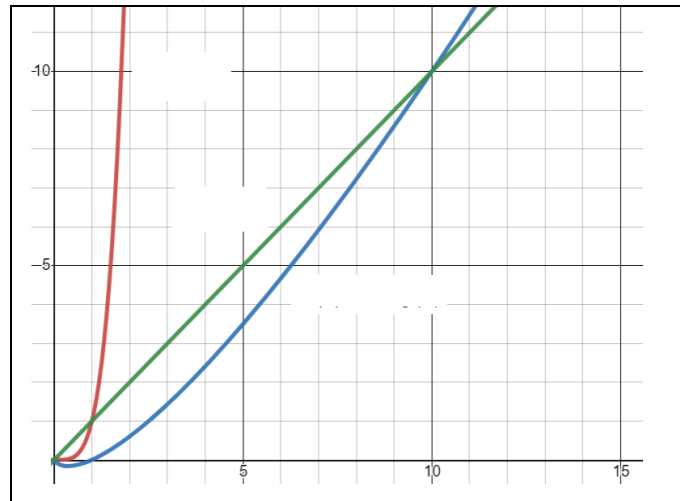

- d) All of these algorithms L, M, N can be used to solve a particular problem X. What is the time complexity classification of this particular problem X? Justify your response. (2 marks)

Use the Master Theorem on the recurrence relations below that represent time complexity of various algorithms to find the equivalent function time complexity function $T(f(n))$.

e) $T(n) = 4T\left(\frac{n}{2}\right) + n^2, T(1)=O(1)$ (1 mark)

f) $T(n) = T\left(\frac{n}{3}\right) + \sqrt{n}, T(1)=O(1)$ (1 mark)

Question 5 (7 marks)

A Transport company will use a plane to deliver the most valuable set of items possible to a remote location in one trip without exceeding the plane's loading capacity.



There are n items that can be selected

item	1	2	3	i		n
weight	w_1	w_2	w_3		w_i		w_n
value	v_1	v_2	v_3		v_i		v_n

- a) What is the classification of this type of problem using conventions of Computer Science? What is the implication for solvability of this problem? Justify your responses. (2 marks)

The problem of plane transportation is changed so that the company needs to make sure that the value of the items transported in one plane trip while staying within the plane's load capacity is at least \$100 000. A cargo value of at least \$100 000 covers all the costs and gives a very good profit.

- b) How does this change the re-classification of the problem? Explain your reasoning. (2 marks)

- c) Why are heuristics used in computer science to solve problems? Give an example of a problem that uses heuristic algorithms. What features of that problem indicate a heuristic solution needs to be used? (3 marks)

Question 6 (5 Marks)

Catalan Numbers are a special kind of number that is generated by the following expression:

$$C_0 = 1 \quad \text{and} \quad C_{n+1} = \sum_{i=0}^n C_i C_{n-i} \quad \text{for } n \geq 0;$$

Alternatively expressed as

$$C_0=1, C_{n+1}=C_0C_n+C_1C_{n-1}+\dots+C_kC_{n-k}+\dots+C_nC_0$$

The first Catalan numbers for $n = 0, 1, 2, 3, 4, 5$ are 1, 1, 2, 5, 14, 42

A Naïve algorithm “C” for calculating Catalan numbers is shown below, where $C(0) = 1$:

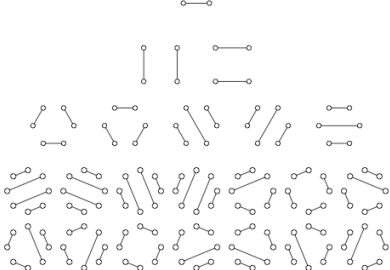
<pre> Function C(input integer: n) If (n==0) then return 1 End if sum:=0 For i=1 to n do sum:=sum+C(i-1)*C(n-i) End do return sum End Function </pre>	 <p>Catalan numbers count the total number of non-crossing perfect matchings in the complete graph K_{2n} http://rosalind.info/glossary/catalan-numbers/</p>
--	---

a) Show a call graph/tree for the instance when the algorithm is called **C(4)** (2 marks)

b) Hence using the call tree, what kind of time complexity do you estimate for Function C? (1 mark)

c) Can the Master Theorem be used to calculate the time complexity of this algorithm? Explain your answer (2 marks).

Question 7 (9 marks)

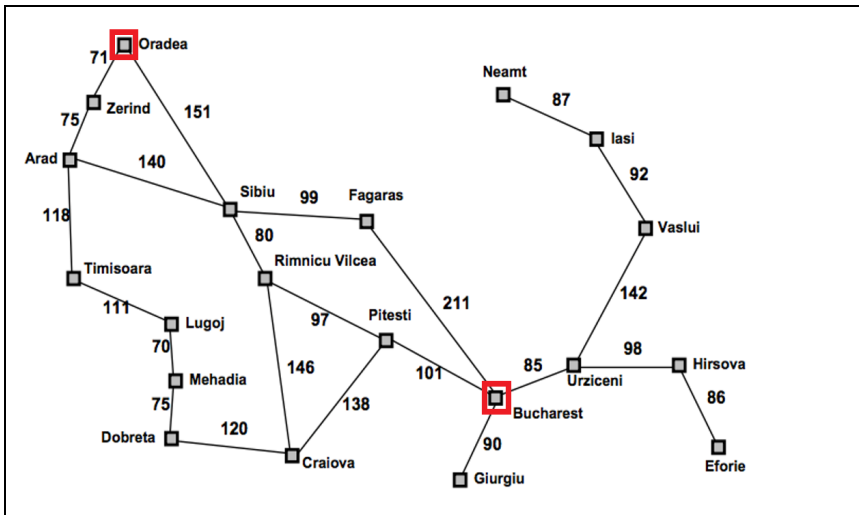

Consider the following road map of a small region of Romania showing the distance in kilometres between towns/cities.

Dorina who is a Computer Scientist lives in Oradea and wishes to visit her friend Anton who lives in Bucharest.

- a) Describe a model and a “Best First Search” approach that could be used by Dorina to find the best route from the town of “Oradea” to the city of “Bucharest”. (4 marks)

- b) What are the principles of the best first heuristic algorithm? How does it compare to Greedy Algorithm strategies? How does it find a “good” solution for a problem. (2 marks)

- c) How does the Best First search approach compare with the A* search method? Describe A* search and compare and identify any similarities and differences in the two approaches. (3 marks)

Question 8 (10 marks)

a) Describe the main components of a Turing machine (TM) and the functions they perform. (2 marks)

Consider the following state diagram for a Turing Machine, where “b” indicates a blank:

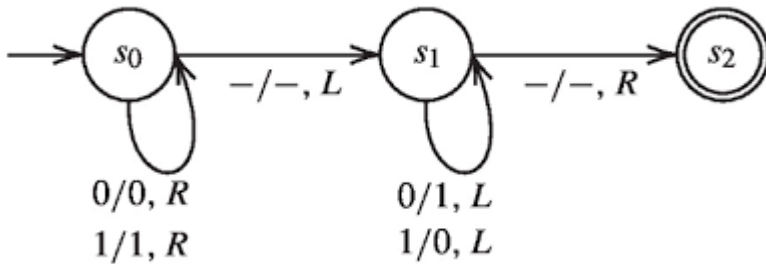

TM LEGEND

States: s_0, s_1, s_2

Edge Transitions:

Input Symbol/Output Symbol/Move

Symbols: 0, 1, -

Move: L (left), R (right)

b) This 3 state Turing machine is run on the tape containing the sequence -101- and is starting at the third element 0 when in state s_0 . Show the Turing Machine Execution progression until it halts. (2 marks)

State	Tape Contents Sequence

c) Translate this Turing Machine to a tabular system of rules. (2 marks)

Current State	Input Symbol	Output Symbol	Move	New State

Question 8 (continued)

Finite state machines and Turing machines are models of computation, or hypothetical examples of machines, used as examples to state how much a certain machine/coding language can or needs to do.

A finite state machine (FSM) is a machine that has something called a state, and can receive inputs. The inputs change the state. For example: A turnstile for entry into a building can be modeled as a FSM.



It has two states: either it is locked or unlocked.
If it's locked and it gets a coin, it goes into the unlocked state.
If it's unlocked and it gets a coin, nothing happens, so it stays unlocked.
If it's locked and it gets pushed, nothing happens, so it stays locked.
If it's unlocked and it gets pushed, it goes into the locked state.

d) Show the information for the Turnstile FSM as a state/transition graph. (2 marks)

A few more cases may occur that need to be considered for the turnstile to operate correctly and need to be included in the operation.

- The coin inserted must have a certain value for the turnstile to open.*
- In the case of a fault there needs to be a manual override to open the turnstile.*

e) Create a new state/transition graph depicting the FSM to handle the existing and the extra cases. (2 marks)

Question 9 (7 marks)

a) What are the main features of comparison for Weak AI versus Strong AI? (3 marks)

Weak AI	Strong AI

The Turing test is conducted as follows:

1. A human evaluator engages in a natural language conversation with two other parties, one of which is a human and the other of which is a machine designed to generate human-like responses.
2. All participants are separated from one another. The evaluator is allowed to ask the other two parties any questions they wish, and the other two parties are allowed to respond to the evaluator's questions in any way they choose.
3. If the evaluator cannot reliably tell the machine from the human, the machine is said to have passed the Turing test.

b) How is the Turing test is related and compared to weak AI and strong AI? (2 marks)

c) How is Searles' Chinese Room Thought experiment related and compared to weak AI and strong AI? (2 marks)

Question 10 (8 marks)

A **Latin square** is an $n \times n$ array filled with n different symbols, each occurring exactly once in each row and exactly once in each column. An example of a 3x3 Latin square using the symbols A, B, C is shown at the right.

A	B	C
B	C	A
C	A	B

Initial State	Goal State (s)																											
<table border="1"> <tr> <td>A</td> <td>B</td> <td>C</td> </tr> <tr> <td></td> <td></td> <td></td> </tr> <tr> <td></td> <td></td> <td></td> </tr> </table>	A	B	C							<table border="1"> <tr> <td>A</td> <td>B</td> <td>C</td> </tr> <tr> <td>B</td> <td>C</td> <td>A</td> </tr> <tr> <td>C</td> <td>A</td> <td>B</td> </tr> </table> <table border="1"> <tr> <td>A</td> <td>B</td> <td>C</td> </tr> <tr> <td>C</td> <td>A</td> <td>B</td> </tr> <tr> <td>B</td> <td>C</td> <td>A</td> </tr> </table>	A	B	C	B	C	A	C	A	B	A	B	C	C	A	B	B	C	A
A	B	C																										
A	B	C																										
B	C	A																										
C	A	B																										
A	B	C																										
C	A	B																										
B	C	A																										

- a) Show the decision tree that would arise from the root node or initial state of the Latin square if the backtracking method of progressing toward the goal state(s) was being used. (2 marks)

- b) What is the time complexity of the backtracking design pattern for solving this problem? What are the advantages and disadvantages as it compare with the Brute Force approach? Justify your responses. (2 marks)

Question 10 (continued)

- c) Write a backtracking algorithm to solve the 3 x 3 Latin Square problem with symbols A, B, C.
(4 marks)

END OF TRIAL EXAM 1