



## GENERAL COMMENTS

The 2013 Chemistry examination, the first two-and-a-half hour end-of-year examination, was based on the key knowledge and key skills for both Units 3 and 4. Well-prepared students were able to attempt, and generally complete, all questions on the examination within the allocated time.

There were many questions in Section B that required detailed explanations. Performance on Question 9a., which was based on spectra interpretation, was stronger than performance on Question 11b., which was based on judgment of the chemical validity of statements about catalysts. Question 11b. was a question type less familiar to students, but it was clear that some students had underestimated the amount of detail expected in responses to this question. In Question 4a.ii. some students struggled to explain the effect of volume change on two specified equilibria. Question 5b. asked students to define the terms 'equivalence point' and 'end point'. Given the significance of equivalence point and end point, particularly in volumetric analysis, many responses lacked the expected detail. Responses to Question 4d. indicated that students did not have a good understanding of the reasons why fuels are classified as renewable or non-renewable. Question 8b. and Question 8d. were challenging for some students. When asked to describe factors that might affect the accuracy of the results, students should try to answer in terms of the context of the question and avoid general statements such as 'the balance might have been faulty'. Accurate chemical language is also very important. There is significant difference between the correct chemical statement 'gold cations are a stronger oxidant than copper cations' and the chemically incorrect statement 'gold is a stronger oxidant than copper'. In Question 3e. students needed not only to name the bond type but also to describe where it occurs.

The ability to write equations is fundamental in chemistry and was assessed in Questions 2a., 4bi., 4bii., 8ai, 8b. and 10bii. Students are expected to include states in all balanced equations. However, these states should be sensible. To have (aq) as the state of the fuel in the combustion equations in Question 8ai. and Question 10bii. was not sensible. Students are expected to consider significant figures in final answers to all numerical questions. Students should avoid excessive rounding off during calculations as this may lead to final answers falling beyond the acceptable limits of accuracy. Question 3a. showed that many students struggled to accurately represent the peptide group. Question 4b. revealed inconsistencies in understanding of the significance of the nature of the electrolyte in hydrogen-oxygen fuel cells. Question 5c. revealed that many students had not understood the chemistry of weak acids, both in writing the equilibrium law and using that law with information from the Data Book in associated calculations.

Chemistry requires familiarity with a variety of calculation techniques, most requiring application of the mole concept. Questions 7b., 7c., 8a.ii. and 10b.iii. revealed issues with the application of appropriate techniques. Fundamentals such as the role of equation coefficients, calculations of numbers of moles according to relationships with which students should be well familiar, and the importance of units never change. The importance of effective interpretation of the question cannot be overemphasised.

Some questions in Section A proved quite challenging for students. Question 3 tested understanding of the impact of incorrect rinsing procedures on titration equipment. Question 4 tested awareness of analysis situations where back titration would be appropriate. Question 6 tested the ability to recognise reaction type from the given equation. Question 13 required interpretation of an unfamiliar reaction pathway. Questions 19 and 20 tested understanding of the difference between acid strength and concentration and the effect of concentration on percentage ionisation of a weak acid. Question 21 tested interpretation of equilibrium constant values. Question 25 tested understanding of the limitations of the electrochemical series. In Question 28 many students chose an alternative that suggested they did not read the question properly. Question 29 required recognition that the supplied data needed to be rearranged. Question 30 required recognition that a check of the electrochemical series was necessary and the ability to correctly use the relationship between  $n(e^-)$  and  $n(\text{metal})$ .

Students can choose whether they answer Section A or Section B first, and could trial different approaches when completing practice exams. Although questions on the examination may look different, or be in a context that students have not previously encountered, the chemical principles and key knowledge required are those that students should have applied extensively throughout the year. Consistent application and regular revision throughout the year are key components of success. A strong focus on 'question interpretation' is recommended. As part of their learning and examination preparation students should be encouraged to discuss the content and context of questions, particularly when reflecting on incorrect answers. Students need to remember that the examination is designed to test their ability to apply their knowledge and understanding in familiar and new contexts, and in most questions this requires more than



simple recall of facts. The exam will include some questions designed to assess higher-order-thinking skills such as analysis and evaluation.

## SPECIFIC INFORMATION

This report provides sample answers or an indication of what answers may have included. Unless otherwise stated, these are not intended to be exemplary or complete responses.

The statistics in this report may be subject to rounding errors resulting in a total less than 100 per cent.

### Section A – Multiple-choice questions

The table below indicates the percentage of students who chose each option. The correct answer is indicated by shading.

Question	% A	% B	% C	% D	Comments
1	72	10	11	7	All three pieces of supplied data (6.9 g, 0.07500 L and 11.5 °C), as well as the gas constant (8.31) and the molar mass of argon (39.9), are used in calculating the pressure. The calculated pressure should have been expressed to the same number of significant figures as the piece of data used in the calculations that had the fewest significant figures, i.e. two significant figures consistent with 6.9 g of argon.
2	5	77	14	3	According to the pH curve, the pH at the equivalence point is close to 10. The pH ranges over which the indicators change colour were given in Table 11 of the Data Book. The least suitable indicator is the one that changes furthest away from pH 10, i.e. thymol blue (1.2–2.8). Alternatively, the fact that thymol blue would change colour at a pH range off the graph is convincing evidence for option B.
3	38	16	30	16	Fundamentally, this question involved identifying which of the statements most accurately described the effect of rinsing procedures on the titre volume. The question implied that one of the pieces of glassware used was incorrectly rinsed. While water left in the titration flask is not inappropriate, it was only option A that correctly described the impact of the rinsing procedures described in the question. Option A: Residual water in the titration flask does not affect the $n(\text{NaOH})$ added in the 20.00 mL aliquot nor the titre volume, i.e. titre volume is 25.00 mL. Option B: Rinsing the burette with water means that residual traces of water will dilute the acid added to the burette. This means that a larger $V(\text{HCl})$ will need to be added to reach the equivalence point, hence the titre would be greater than 25.00 mL. Option C: If the pipette is rinsed with water, residual traces of water will mean less $\text{NaOH}(\text{aq})$ will be present in the 20.00 mL aliquot. Hence, a smaller $V(\text{HCl})$ is needed to reach the equivalence point, and the titre volume will be less than 25.00 mL. Option D: If the titration flask was rinsed with acid, the residual acid will react with some of the $\text{NaOH}$ added in the aliquot. Less $\text{HCl}$ then needs to be added from the burette, so the titre volume will be less than 25.00 mL.
4	8	26	43	23	A back titration is effectively a two-stage analytical technique. 1. A reactant of unknown concentration is reacted with an excess of a reactant of known concentration. 2. The amount of the second reactant remaining unreacted, i.e. in excess, is determined via an appropriate titration. All the cases listed in the question could involve back titration. In cases I and II there are alternatives to back titration. Analysis of the ammonia (a volatile substance) content of a cleaning agent is often done by direct titration of a diluted sample of the cleaning agent. Determination of the calcium carbonate (insoluble in water) content of eggshells can involve precipitation of the $\text{Ca}^{2+}(\text{aq})$ after dissolving in acid rather than titration (Question 2b). Back titration may be considered suitable in the sense that, in case I, reacting the cleaning agent sample with excess base should reduce losses to the atmosphere more than dilution. While in case II, back titration avoids the potential of errors associated with producing and collecting precipitate.

# 2013 Examination Report

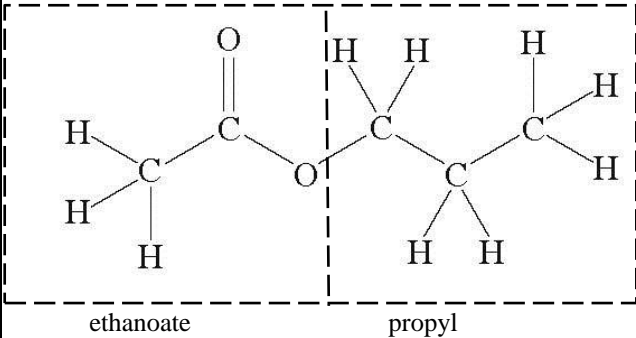

Question	% A	% B	% C	% D	Comments
					The popularity of option C may, in part, have been due to some unfamiliarity with volatile substances and/or having analysed one by direct titration. While there may be some debate about the interpretation of the term 'more suitable', it was considered that option D was the <b>best</b> answer to this question.
5	15	12	66	6	Since the flasks are identical, i.e. the same volume, and the temperature and pressure conditions are the same, both flasks must contain the same number of mole of gas. $n(\text{N}_2) = 5.0/28.0$ $= 0.179 \text{ mol}$ $n(\text{unknown}) = 14.4/M(\text{unknown}) \rightarrow 0.179 = 14.4/M(\text{unknown})$ $M(\text{unknown}) = 14.4/0.179$ $= 80.6 \text{ g mol}^{-1}$ $M(\text{H}_2) = 2.0 \text{ g mol}^{-1}; M(\text{SO}_2) = 96.1 \text{ g mol}^{-1}$ $M(\text{HBr}) = 80.9 \text{ g mol}^{-1}$ $M(\text{C}_4\text{H}_{10}) = 58.0 \text{ g mol}^{-1}$
6	55	24	10	11	Option A – a redox reaction. The oxidation number of Al increases from 0 to +3 The oxidation number of Cl decreases from 0 to –1 Option B – precipitation Option C – neutralisation Option D – condensation/esterification  The choice of option B suggests some misconceptions relating to the formulas of ionic compounds.
7	71	24	1	4	With a polar stationary phase, it will be the most polar molecule in the mixture that is most strongly attracted to the stationary phase. The molecule most attracted to the stationary phase moves the smallest distance from the origin. Hence, sample A.
8	5	11	79	5	The analysis technique, from those listed, that is specific to metals is atomic absorption spectroscopy.
9	1	18	73	8	
10	7	89	3	1	
11	9	17	63	12	Ionic interactions in proteins occur only in the tertiary structure. Hence, substances that specifically disrupt ionic interactions may be expected to affect only the tertiary structure.

# 2013 Examination Report



Question	% A	% B	% C	% D	Comments
12	61	12	6	21	<p>The structures for adenine and thymine were given in the Data Book.</p> <div style="display: flex; justify-content: space-around; align-items: center;"> <div style="text-align: center;"> <p>adenine</p> </div> <div style="text-align: center;"> <p>thymine</p> </div> </div> <p>The asterisked (*) N atom in each molecule is the one that forms a covalent bond with C(1') on deoxyribose. The hashed (#) sites on the two bases show the sites for hydrogen bonding between adenine on one strand and thymine on the adjacent strand of a DNA double helix. To facilitate this, the adenine molecule has to be considered as if rotated through 180° horizontally. This is consistent with option A. Options B, C and D were all inconsistent with the conditions for hydrogen bonding.</p>
13	15	41	31	12	<p>Reduction and oxidation can both be defined in terms of the transfer of oxygen, hydrogen and electrons as well as changes in oxidation number.</p> <p>Reduction is defined as</p> <ul style="list-style-type: none"> <li>• gain of electrons</li> <li>• decrease in oxidation number</li> <li>• loss of oxygen</li> <li>• gain of hydrogen.</li> </ul> <p>The latter two definitions can be used to quickly identify oxidation and reduction in organic reactions, but are not fully definitive because some organic reactions may not involve changes in hydrogen or oxygen content.</p> <p>However, step II in the reaction pathway shown clearly involved only the loss of oxygen and the gain of hydrogen, and so was a reduction reaction.</p> <p>Step I in the pathway was the nitration of phenol. This is not a reaction with which students are expected to be familiar.</p> <p>Step III in the pathway was the formation of an amide by reaction between an amino group and ethanoic anhydride. It has similarities to the formation of an ester group by reaction between a hydroxyl group and ethanoic anhydride in the preparation of aspirin.</p> <p>The popularity of option C was surprising. Students may have been trying to assign oxidation numbers to nitrogen. However, the clearest case of a decrease in oxidation number is in Step II. Since N is less electronegative than O but more electronegative than H, its oxidation number changes from positive to negative.</p>
14	11	6	7	75	Options A, B and C are examples of factors that increase reaction rate.
15	6	2	9	82	
16	12	3	84	1	
17	2	92	1	5	
18	3	3	3	91	
19	15	26	44	14	<p>From Table 12 of the Data Book</p> $K_a(\text{HCOOH}) = 1.8 \times 10^{-4}$ $K_a(\text{CH}_3\text{COOH}) = 1.7 \times 10^{-5}$ <p>A higher <math>K_a \Rightarrow</math> greater extent of ionisation in aqueous solution <math>\Rightarrow</math> higher <math>[\text{H}_3\text{O}^+]</math> and hence a lower pH. So, at the same concentration, <math>\text{CH}_3\text{COOH}</math>, with the lower <math>K_a</math> value, will have the higher pH.</p> <p>When comparing 0.01 M <math>\text{CH}_3\text{COOH}</math> and 1.0 M <math>\text{CH}_3\text{COOH}</math>, since the extent of ionisation increases on dilution, the <math>n(\text{H}_3\text{O}^+)</math> present will be greater in 0.01 M <math>\text{CH}_3\text{COOH}</math>. However, the <math>[\text{H}_3\text{O}^+]</math> will still be lower in 0.01 M <math>\text{CH}_3\text{COOH}</math> than in 1.0 M <math>\text{CH}_3\text{COOH}</math>, so the solution with the highest pH is 0.01 M <math>\text{CH}_3\text{COOH}</math>.</p>

# 2013 Examination Report



Question	% A	% B	% C	% D	Comments
					<p>This can be verified mathematically using <math>K_a = \frac{[H^+]^2}{[HA]}</math></p> <p>0.01 M HCOOH; <math>1.8 \times 10^{-4} = \frac{[H^+]^2}{0.01} \rightarrow [H^+] = 1.34 \times 10^{-3} \text{ M} \rightarrow \text{pH} = 2.9</math></p> <p>1.0 M HCOOH; <math>1.8 \times 10^{-4} = \frac{[H^+]^2}{1.0} \rightarrow [H^+] = 1.34 \times 10^{-2} \text{ M} \rightarrow \text{pH} = 1.9</math></p> <p>0.01 M CH<sub>3</sub>COOH; <math>1.7 \times 10^{-5} = \frac{[H^+]^2}{0.01} \rightarrow [H^+] = 4.12 \times 10^{-4} \text{ M} \rightarrow \text{pH} = 3.4</math></p> <p>1.0 M CH<sub>3</sub>COOH; <math>1.7 \times 10^{-5} = \frac{[H^+]^2}{1.0} \rightarrow [H^+] = 4.12 \times 10^{-3} \text{ M} \rightarrow \text{pH} = 2.4</math></p> <p>The higher concentration of the acid with the higher <math>K_a</math> has the lowest pH. The lower concentration of the acid with the smaller <math>K_a</math> has the highest pH. Students who chose alternative B were mistaken on two counts: the relationship between <math>K_a</math> value and pH for solution of equal concentration and the effect of dilution on the overall concentration of H<sub>3</sub>O<sup>+</sup>.</p>
20	49	10	18	22	<p>The equilibrium nature of aqueous solutions of weak acids causes the extent of ionisation to increase on dilution.</p> $\text{CH}_3\text{COOH}(\text{aq}) \rightleftharpoons \text{CH}_3\text{COO}^-(\text{aq}) + \text{H}^+(\text{aq})$ <p>On dilution, the concentration of all the species present decreases and the system is pushed out of equilibrium. The system tries to partially oppose this change, and increase the overall concentration, by favouring the direction that produces more particles – i.e. the forward reaction – thus increasing the amount of ethanoic acid that ionises.</p> <p>Since 0.01 M CH<sub>3</sub>COOH(aq) is the most dilute of the ethanoic acid solutions it will be the one with the highest percentage ionisation.</p> <p>The choice of option A by a large number of students suggests that the impact of dilution on the ionisation of weak acids was not well understood. The effect can be verified mathematically.</p> <p>In 1.0 M CH<sub>3</sub>COOH(aq), <math>[H^+] = 4.12 \times 10^{-3} \text{ M} \cong [\text{CH}_3\text{COO}^-]</math>  <math>\% \text{ ionisation} = \frac{4.12 \times 10^{-3}}{1.0} \times 100 = 0.41 \%</math></p> <p>In 0.01 M CH<sub>3</sub>COOH(aq), <math>[H^+] = 4.12 \times 10^{-3} \text{ M} \cong [\text{CH}_3\text{COO}^-]</math>  <math>\% \text{ ionisation} = \frac{4.12 \times 10^{-3}}{0.01} \times 100 = 4.1 \%</math></p>
21	40	13	10	36	<p>The <math>K_{a1}</math> value for the first ionisation of H<sub>3</sub>PO<sub>4</sub>(aq) is over 100 000 times larger (<math>7.25 \times 10^{-3}/6.31 \times 10^{-8} = 1.15 \times 10^5</math>) than the <math>K_{a2}</math> value for the second ionisation which, in turn, is over 100 000 times greater than the <math>K_{a3}</math> value for the third ionisation.</p> <p>The first ionisation will make by far the greatest contribution to the [H<sub>3</sub>O<sup>+</sup>], and so <math>K_{a1}</math> would be used to determine the approximate pH of 0.1 M H<sub>3</sub>PO<sub>4</sub>.</p>
22	3	2	76	19	<p>Since coal, crude oil and uranium are non-renewable, the only viable option was option C – ethanol, methane and (bio)diesel can all be produced from renewable sources.</p>
23	9	18	65	8	<p>Energy absorbed by water = <math>4.18 \text{ J g}^{-1} \text{ }^\circ\text{C}^{-1} \times m(\text{H}_2\text{O}) \times \Delta T</math>  <math>= 4.18 \times 1000 \times 10.6</math>  <math>= 4.43 \times 10^4 \text{ J}</math></p> <p><math>n(\text{NaOH}) = 40 \text{ g}/40.0 \text{ g mol}^{-1} = 1.0 \text{ mol}</math></p> <p>1.0 mol NaOH releases <math>4.4 \times 10^4 \text{ J}</math>. i.e. 44 kJ</p>
24	67	10	8	14	<p>Since Fe is a reductant, reaction may be predicted to occur if the solution contains an oxidant higher on the electrochemical series, i.e. with a higher <math>E^\circ</math> than Fe.</p> <p>Pb<sup>2+</sup>(aq)/Pb(s) <math>E^\circ = -0.13 \text{ V}</math>          Ni<sup>2+</sup>(aq)/Ni(s) <math>E^\circ = -0.23 \text{ V}</math>          Fe<sup>2+</sup>(aq)/Fe(s) <math>E^\circ = -0.44 \text{ V}</math>          Zn<sup>2+</sup>(aq)/Zn(s) <math>E^\circ = -0.76 \text{ V}</math></p> <p>The choice of option D showed ineffective use of the electrochemical series to predict possible reaction.</p>
25	7	35	15	42	<p>According to the electrochemical series, H<sub>2</sub>O<sub>2</sub>(aq) can act as both an oxidant and a reductant</p> $\text{H}_2\text{O}_2(\text{aq}) + 2\text{H}^+(\text{aq}) + 2\text{e}^- \rightleftharpoons 2\text{H}_2\text{O}(\text{l}) \quad +1.77 \text{ V}$ $\text{O}_2(\text{g}) + 4\text{H}^+(\text{aq}) + 4\text{e}^- \rightleftharpoons 2\text{H}_2\text{O}(\text{l}) \quad +1.23 \text{ V}$

# 2013 Examination Report



Question	% A	% B	% C	% D	Comments
					$\text{O}_2(\text{g}) + 2\text{H}^+(\text{aq}) + 2\text{e}^- \rightleftharpoons \text{H}_2\text{O}_2(\text{aq}) \quad +0.68 \text{ V}$ and is a stronger reductant than $\text{H}_2\text{O}(\text{l})$ . The conditions of the half-cells are standard conditions: 1 M, SLC – 25°C and 101.3 kPa. Hence, the most likely reaction for not observing the expected reaction is that the rate of reaction is extremely slow.  Students should be aware that <ul style="list-style-type: none"> <li>the electrochemical series provides no information about reaction rate. So while reactions may be predicted to occur, changes may not be observed in a short period of time</li> <li>reactions, under standard conditions, may be predicted to occur between the strongest oxidant present and the strongest reductant present.</li> </ul>
26	15	10	7	69	Cell 1: 0.75 V, Cell 2: 0.62 V, Cell 3: 0.55 V, Cell 4: 1.05 V
27	8	63	11	17	$\text{Fe}^{3+}(\text{aq}) + \text{e}^- \rightleftharpoons \text{Fe}^{2+}(\text{aq})$ $\text{Co}^{2+}(\text{aq}) + 2\text{e}^- \rightleftharpoons \text{Co}(\text{s})$ Oxidation $\text{Co}(\text{s}) \rightarrow \text{Co}^{2+}(\text{aq}) + 2\text{e}^-$ , at the anode Reduction $\text{Fe}^{3+}(\text{aq}) + \text{e}^- \rightarrow \text{Fe}^{2+}(\text{aq})$ , at the cathode
28	5	5	48	42	The salt used in salt bridge must <ul style="list-style-type: none"> <li>be soluble in water</li> <li>not react with components of either half-cell, i.e. cannot contain a strong oxidant or a strong reductant.</li> </ul> Also, in the cell, cations migrate towards the cathode and anions migrate towards the anode.
29	14	56	18	11	It was important that students made decisions based on the half-equations in order of decreasing $E^\circ$ values, i.e. $\text{PbO}_2(\text{s}) + \text{SO}_4^{2-}(\text{aq}) + 4\text{H}^+(\text{aq}) + 2\text{e}^- \rightleftharpoons \text{PbSO}_4(\text{s}) + 2\text{H}_2\text{O}(\text{l}) \quad 1.69 \text{ V}$ $\text{PbSO}_4(\text{s}) + 2\text{e}^- \rightleftharpoons \text{Pb}(\text{s}) + \text{SO}_4^{2-}(\text{aq}) \quad -0.36 \text{ V}$ Half-equations for the reaction occurring during recharging – an electrolytic process in which an external power source is used – are Anode (+) $\text{PbSO}_4(\text{s}) + 2\text{H}_2\text{O}(\text{l}) \rightarrow \text{PbO}_2(\text{s}) + \text{SO}_4^{2-}(\text{aq}) + 4\text{H}^+(\text{aq}) + 2\text{e}^-$ Cathode (–) $\text{PbSO}_4(\text{s}) + 2\text{e}^- \rightarrow \text{Pb}(\text{s}) + \text{SO}_4^{2-}(\text{aq})$ Only option B was consistent with these half-equations: $\text{PbSO}_4$ is oxidised to $\text{PbO}_2$ (oxidation number of Pb increases from +2 to +4) and reduced to Pb (oxidation number of Pb decreases from +2 to 0).
30	15	28	22	35	Metals are produced by electrolysis of aqueous solutions of their cations if the metal cations are stronger oxidants than water. According to the electrochemical series $\text{Ag}^+(\text{aq}) + \text{e}^- \rightarrow \text{Ag}(\text{s}) \quad 0.80 \text{ V}$ $\text{Fe}^{2+}(\text{aq}) + 2\text{e}^- \rightarrow \text{Fe}(\text{s}) \quad -0.44 \text{ V}$ $2\text{H}_2\text{O}(\text{l}) + 2\text{e}^- \rightarrow \text{H}_2(\text{g}) + 2\text{OH}^-(\text{aq}) \quad -0.83 \text{ V}$ $\text{K}^+(\text{aq}) + \text{e}^- \rightarrow \text{K}(\text{s}) \quad -2.93 \text{ V}$ Ag(s) and Fe(s) will be produced, but no K(s) will be produced. Since the same current is applied to all three cells for 5 minutes, the same $n(\text{e}^-)$ flows in each cell. $n(\text{Ag}) \text{ produced} = n(\text{e}^-) \rightarrow m(\text{Ag}) \text{ produced} = n(\text{e}^-) \times 107.9 \text{ g}$ $n(\text{Fe}) \text{ produced} = \frac{1}{2} \times n(\text{e}^-) \rightarrow m(\text{Fe}) \text{ produced} = \frac{1}{2} \times n(\text{e}^-) \times 55.8 \text{ g}$ In order of increasing mass, the metals deposited are iron and silver. However, since potassium was included in the possible answers, with zero mass deposited, it will be the lowest.  Students who chose options A and B determined that the mass of iron deposited was greater than the mass of silver deposited. This may have been a consequence of misinterpreting the relationship between the $n(\text{Fe})$ produced and the $n(\text{e}^-)$ .



**Section B**

**Question 1a.**

<b>Marks</b>	<b>0</b>	<b>1</b>	<b>Average</b>
<b>%</b>	3	97	

2 (minutes)

**Question 1b.**

<b>Marks</b>	<b>0</b>	<b>1</b>	<b>Average</b>
<b>%</b>	50	50	

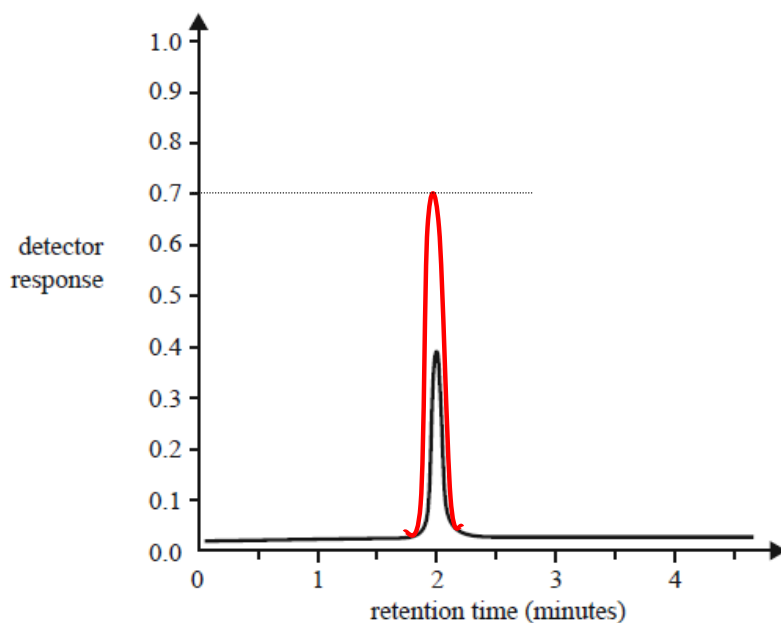

$200 \text{ mg L}^{-1} \rightarrow$  detector response 0.4

$350 \text{ mg L}^{-1} \rightarrow$  detector response  $(0.4/200 \times 350) = 0.7$

Clear indication that the detector response will be 0.7 without the peak being excessively broad was required.

The main issues with this question were in accurate representation of the peak at retention time 2 minutes and the location of the peak at a different retention time.

**Question 2a.**

<b>Marks</b>	<b>0</b>	<b>1</b>	<b>Average</b>
<b>%</b>	75	25	

One of

- $\text{Ca}^{2+}(\text{aq}) + \text{C}_2\text{O}_4^{2-}(\text{aq}) + \text{H}_2\text{O}(\text{l}) \rightarrow \text{CaC}_2\text{O}_4 \cdot \text{H}_2\text{O}(\text{s})$
- $\text{Ca}^{2+}(\text{aq}) + (\text{NH}_4)_2\text{C}_2\text{O}_4(\text{aq}) + \text{H}_2\text{O}(\text{l}) \rightarrow \text{CaC}_2\text{O}_4 \cdot \text{H}_2\text{O}(\text{s}) + 2\text{NH}_4^+(\text{aq})$
- $\text{CaCl}_2(\text{aq}) + (\text{NH}_4)_2\text{C}_2\text{O}_4(\text{aq}) + \text{H}_2\text{O}(\text{l}) \rightarrow \text{CaC}_2\text{O}_4 \cdot \text{H}_2\text{O}(\text{s}) + 2\text{NH}_4\text{Cl}(\text{aq})$ .

While the equation proved challenging for most students, many made simple errors such as an incorrect charge balance or lack of charge on the  $\text{NH}_4^+$  ion.

# 2013 Examination Report



## Question 2b.

Marks	0	1	2	3	Average
%	22	9	18	52	2

$$n(\text{CaC}_2\text{O}_4 \cdot \text{H}_2\text{O}) = 0.523/146.1$$

$$= 3.58 \times 10^{-3} \text{ (0.00358)}$$

$$n(\text{CaCO}_3) = 3.58 \times 10^{-3}$$

$$m(\text{CaCO}_3) = 3.58 \times 10^{-3} \times 100.1$$

$$= 0.358 \text{ g}$$

$$\% \text{ CaCO}_3 = (0.358/0.412) \times 100$$

$$= 87.0 \%$$

One mark each was awarded for

- accurately calculating  $n(\text{CaC}_2\text{O}_4 \cdot \text{H}_2\text{O})$
- accurately calculating  $m(\text{CaCO}_3)$  from the calculated  $n(\text{CaC}_2\text{O}_4 \cdot \text{H}_2\text{O})$
- correctly calculating % by mass from  $n(\text{CaCO}_3)$ .

Errors on this question included: use of incorrect molar masses, working out the percentage by mass of calcium instead of calcium carbonate and using the precipitate mass rather than the eggshell mass in calculating the percentage  $\text{CaCO}_3$ .

## Question 3a.

Marks	0	1	2	Average
%	36	48	17	0.8

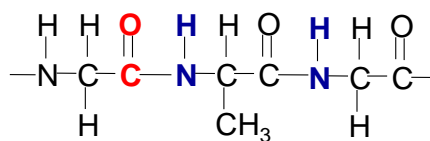
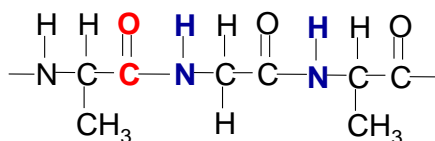

One mark each was awarded for

- $-\text{CH}_3$  and  $-\text{H}$  Z-groups and alternation
- two correct peptide groups or, if showing more than three residues, total number of peptide groups one less than the total number of residues and open bonds at both ends of the structure.

Many students were unable to correctly represent the peptide group in their structures. The use of structures such as  $\text{+gly-ala-gly+}_m$  was not accurate because it was not consistent with the amino acids alternating right along the chain.

## Question 3b.

Marks	0	1	Average
%	23	77	0.8

One of

- peptide bond/group
- amide bond
- covalent bond.

## Question 3c.

Marks	0	1	Average
%	27	73	0.8

condensation (polymerisation)

Students should be aware of the difference between condensation polymerisation and addition polymerisation.



# 2013 Examination Report



## Question 3d.

Marks	0	1	Average <b>0.4</b>
%	65	35	

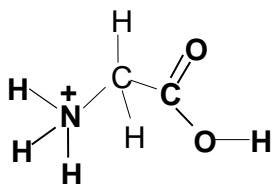

Common errors included showing the structure of the zwitterion or a deprotonated carboxyl group. A significant number of students who had identified the correct species then used the incorrect (+) charge location.

Students should be able to draw the structures of the zwitterion, protonated (low pH) and deprotonated (high pH) forms of amino acids.

## Question 3e.

Marks	0	1	2	Average <b>0.8</b>
%	36	51	13	

Hydrogen bonding between the H atom on one peptide group and the O atom on a different peptide group in the same polymer chain

One mark each was awarded for hydrogen bonding and for identifying the atoms, on the peptide groups, between which the hydrogen bonding occurs.

There was evidence of significant confusion between secondary and tertiary structures of a protein, with many students mentioning hydrogen bonding along with covalent and other bond types. The key part of this question was the description of the bonds that contribute to the spiral secondary structure of the protein. This required more than simply identifying the bond type, i.e. the atoms between which it occurs – H and O on different peptide groups in the protein chain.

## Question 4

### 4ai.

Marks	0	1	2	3	Average <b>2.3</b>
%	5	14	25	55	

Change to reaction I and reaction II	Effect of the change on the hydrogen yield in reaction I	Effect of the change on the hydrogen yield in reaction II
addition of steam at a constant volume and temperature	increase	increase
increase in temperature at a constant volume	increase	decrease
addition of a suitable catalyst at a constant volume and temperature	no change	no change

The addition of steam favours both forward reactions, increased temperature favours the endothermic reaction and the addition of a catalyst has no effect on the extent of either reaction.

# 2013 Examination Report



## 4a.iii.

Marks	0	1	2	3	4	Average
%	22	13	14	17	35	2.3

Reaction 1: Equilibrium yield of H<sub>2</sub> decreases

Decreasing the volume increases the overall pressure (concentration). The system moves to partially compensate and decrease the pressure (concentration) by favouring the side with fewer particles (moles of particles), i.e. the reverse/back reaction is favoured. Similarly, decreasing the volume causes the concentration fraction to increase. To return to equilibrium, the concentration fraction must decrease, and so the reverse reaction is favoured.

Reaction 2: Equilibrium yield of H<sub>2</sub> does not change

Although the pressure increases, the system is not pushed out of equilibrium because there is the same number of particles (moles) on both sides/the system cannot respond to a pressure increase because there are the same number of particles on both sides. Alternatively, decreasing the volume for a system with the same number of moles on both sides has no effect on the concentration fraction, so the equilibrium yield of hydrogen does not change.

Students should be aware that when a change is imposed on an equilibrium system it should respond in such a way as to partially oppose the change (Le Châtelier's principle). Students should be well versed in the response to a increase in pressure – moving to compensate by favouring the reaction that will lower the pressure, i.e. the side of the equilibrium with fewer particles (except in cases where there is the same number of particles on both sides of the equilibrium).

## 4a.iii.

Marks	0	1	2	Average
%	25	34	41	1.2

- Reaction I: the reaction rate will increase/reaction will be faster.
- Reaction II: the reaction rate will increase/reaction will be faster.

This question required students to give a statement of what happens to the reaction rate for each reaction.

Many students focused on the connection between yield and the thermochemistry ( $\Delta H$ ) of each reaction and explicitly dealt with the effect of a temperature increase on equilibrium yield rather than reaction rate. Students should consider collision theory when deciding on how changes impact on reaction rate. An increase in temperature increases the kinetic energy of all particles. This increases the proportion of collisions with energy greater than the activation energy and hence the rate of reaction. This applies whether the reaction is exothermic or endothermic.

Students should be aware that for an equilibrium with an exothermic forward reaction (for example, reaction II), an increase in temperature will decrease the yield of product but increase the rate of reaction.

## Question 4b.

Overall performance on Questions 4bi. and 4bii. was well below expectations. Despite 'alkaline' being clearly emphasised in the question, H<sup>+</sup>(aq) was common in one or both half-equations. The half-equations were available in Table 2 of the Data Book – the electrochemical series.

The half-equation O<sub>2</sub>(g) + 4H<sup>+</sup>(aq) + 4e<sup>-</sup> → 2H<sub>2</sub>O(l) was prevalent in responses, suggesting that students chose the O<sub>2</sub> highest on the electrochemical series without considering the nature of the electrolyte.

Many students had the oxidation and reduction half-equations at the wrong electrodes. Students should be well aware that the cathode is the site of reduction and the anode is the site of oxidation.

## 4bi.

Marks	0	1	Average
%	68	32	0.3

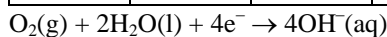

# 2013 Examination Report



4bii.

Marks	0	1	Average
%	66	34	<b>0.4</b>

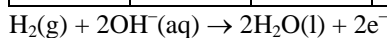

4c.

Marks	0	1	Average
%	31	69	<b>0.7</b>

1.23 (V)

1.23 V is the voltage predicted from the electrochemical series for a hydrogen-oxygen fuel cell, whether the electrolyte is acidic or alkaline. The mark was also awarded if the voltage was consistent with incorrect half-equations provided in Questions 4bi. and 4bii.

Students should be aware that cell voltage, at 25°C, 101.3 kPa and 1 M solutions, is predicted by computing the difference in  $E^\circ$  values on the electrochemical series.

4d.

Marks	0	1	2	Average
%	45	28	26	<b>0.8</b>

Renewable methane is produced from plant material that can be readily replenished in a short period of time.

Non-renewable methane is from natural gas, a fossil fuel that cannot be easily or quickly replenished. Fossil fuels take millions of years to form.

Renewable fuels can be produced as fast as they are consumed; fossil fuels are consumed faster than they can be produced.

It was evident that many students did not have a clear understanding of the terms 'renewable' and 'non-renewable' with respect to fuels.

Many responses focused on the impact on CO<sub>2</sub> levels in the environment, used inappropriate descriptions such as 'non-renewable fuels are recyclable' or included superficial statements such as 'renewable fuels are infinite; non-renewable fuels are finite'.

This question was related to the key knowledge dot point, 'Comparison of the renewability of energy sources including coal, natural gas, nuclear fuels and biochemical fuels'. It is recommended that students reflect on the key knowledge dot points for Units 3 and 4 in their examination preparation.

Question 5a.

Marks	0	1	2	Average
%	13	11	77	<b>1.7</b>

$$\begin{aligned} n(\text{NaOH}) &= n(\text{CH}_3\text{COOH}) \\ &= 0.200 \times 20.00 \times 10^{-3} \\ &= 4.00 \times 10^{-3} \text{ mol} \end{aligned}$$

$$\begin{aligned} V(\text{NaOH}) &= 4.00 \times 10^{-3} / 0.150 \\ &= 0.0267 \text{ L} \\ &= 26.7 \text{ mL} \end{aligned}$$

For full marks the answer, in L or mL, needed to include the appropriate unit.

# 2013 Examination Report



## Question 5b.

Marks	0	1	2	Average
%	45	33	22	0.8

- Equivalence point: when the reactants have combined (reacted) in the exact stoichiometric ratio (mole ratio) indicated in the equation/the point in the reaction where no reactant is in excess.
- End point: when the indicator used in the reaction changes colour.

Students' definition of equivalence point needed to make reference to the equation mole ratio.

This question was not well done. There was evidence that many students thought that the equivalence point in an acid-base titration is at pH 7 (at 25 °C). This suggests a disconnect with the use of the indicators, given that most of those listed in Table 11 of the Data Book change colour at pH values other than 7. Phenolphthalein (8.3–10.0) is the indicator normally used for the reaction in this question because the pH at the equivalence point is 8.8. End point descriptions such as 'when a colour change occurs' were far too general; 'indicator colour change' was expected.

Equivalence point and end point are significant components of the study of volumetric analysis.

## 5ci.

Marks	0	1	Average
%	54	46	0.5

One of

- $K_a = [\text{CH}_3\text{COO}^-][\text{H}_3\text{O}^+]/[\text{CH}_3\text{COOH}]$
- $K_a = [\text{CH}_3\text{COO}^-][\text{H}^+]/[\text{CH}_3\text{COOH}]$
- $1.7 \times 10^{-5} = [\text{CH}_3\text{COO}^-][\text{H}^+]/[\text{CH}_3\text{COOH}]$ .

Students should be aware that ethanoic acid – a weak acid listed in Table 12 of the Data Book – will ionise in aqueous solution according to

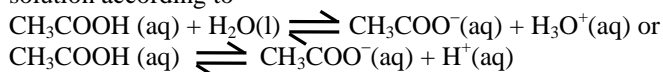

Many students used the equation for the reaction between  $\text{OH}^-(\text{aq})$  and  $\text{CH}_3\text{COOH}(\text{aq})$  as the basis of their equilibrium law, despite the fact that this was not an equilibrium equation.

Another common error was the inclusion of  $[\text{H}_2\text{O}]$  in the equilibrium law.

## 5cii.

Marks	0	1	2	3	Average
%	36	19	5	40	1.5

$$K_a = [\text{CH}_3\text{COO}^-][\text{H}_3\text{O}^+]/[\text{CH}_3\text{COOH}]$$

Apply standard weak acid assumptions:  $[\text{H}_3\text{O}^+] = [\text{CH}_3\text{COO}^-]$ ,  $[\text{CH}_3\text{COOH}] = 0.200 \text{ M}$

$$K_a = [\text{H}_3\text{O}^+]^2/[\text{CH}_3\text{COOH}]$$

$$1.7 \times 10^{-5} = [\text{H}_3\text{O}^+]^2/0.200$$

$$[\text{H}_3\text{O}^+] = \sqrt{(0.200 \times 1.7 \times 10^{-5})}$$

$$= 1.8 \times 10^{-3} \text{ M}$$

$$\text{pH} = -\log_{10}(1.8 \times 10^{-3})$$

$$= 2.73$$

One mark each was awarded for

- correctly substituting into the equilibrium law
- accurately calculating  $[\text{H}_3\text{O}^+]$  from substituted equilibrium law
- accurately calculating pH from  $[\text{H}_3\text{O}^+]$ .

Some students had not mastered the calculation of the pH of a weak acid and other students were comfortable with the determination of pH of weak acids.

# 2013 Examination Report



Some students assumed, incorrectly, that the  $[\text{H}_3\text{O}^+]$  was the same as the  $c(\text{CH}_3\text{COOH})$ , suggesting poor understanding of 'weak acid' chemistry.

A surprising number of students did not access the  $K_a$  value for ethanoic acid provided in Table 2 of the Data Book.

## Question 5d.

This question required students to think deeply about both titration and the equilibrium law for weak acids, but most students did not perform well.

Appropriate approaches would have been

- given that  $\text{NaOH}(\text{aq})$  and  $\text{CH}_3\text{COOH}(\text{aq})$  react in a 1:1 ratio, when exactly half the required  $\text{NaOH}(\text{aq})$  has been added, exactly half the  $\text{CH}_3\text{COOH}(\text{aq})$  will have reacted. Since a product of that reaction is  $\text{CH}_3\text{COO}^-(\text{aq})$ , at that instant there will be equal mole amounts of  $\text{CH}_3\text{COOH}(\text{aq})$  and  $\text{CH}_3\text{COO}^-(\text{aq})$  present
- since  $K_a = \frac{[\text{CH}_3\text{COO}^-][\text{H}_3\text{O}^+]}{[\text{CH}_3\text{COOH}]}$ , when  $[\text{CH}_3\text{COO}^-] = [\text{CH}_3\text{COOH}]$  then  $K_a = [\text{H}_3\text{O}^+]$ .

There were some parallels with indicator chemistry. Students should be aware that only a change in temperature causes a change in  $K_a$  value for a specific equilibrium.

## 5di.

Marks	0	1	Average
%	65	35	0.4

The concentration of ethanoic acid is equal to the concentration of ethanoate ions.

## 5dii.

Marks	0	1	Average
%	76	24	0.3

$[\text{H}_3\text{O}^+] = K_a$ , i.e. they are equal/the same

## Question 6a.

Marks	0	1	Average
%	17	83	0.9

$\text{OH}^-(\text{aq})/\text{NaOH}(\text{aq})/\text{KOH}(\text{aq})/\text{sodium hydroxide}/\text{potassium hydroxide}$

Students should be dissuaded from using  $\text{H}_2\text{O}$  as a reactant on pathways for the formation of alcohols from simple alkyl halides.

## Question 6b.

Marks	0	1	2	3	Average
%	24	12	23	42	1.8

A –  $\text{CH}_2=\text{CH}_2$

B –  $\text{CH}_3\text{CH}_2\text{COOH}$

C –  $\text{CH}_3\text{CH}_2\text{COOCH}_2\text{CH}_3$

While this question was well handled by most students, it was concerning that many could not accurately identify any of the three compounds. Students should be able to apply their knowledge of organic reaction pathways in situations when more than two C atoms are involved.

This question specifically asked for semi-structural formulas. Students should be aware of the difference between molecular formulas, semi-structural formulas and full structural formulas.

The most common inappropriate formulas were  $\text{CH}_3\text{CH}_3$  instead of  $\text{CH}_2=\text{CH}_2$ , and  $\text{CH}_3\text{CH}_2\text{CH}_2\text{COOH}$  instead of  $\text{CH}_3\text{CH}_2\text{COOH}$ . The former suggests some issues in distinguishing between the production of alkanols from alkenes (addition reactions) and from alkanes (substitution reactions). The latter reflects a common misconception that the C in the  $-\text{COOH}$  group is an 'extra' C, rather than the same C as in  $-\text{CH}_2\text{OH}$  prior to oxidation.

# 2013 Examination Report



## Question 6c.

Marks	0	1	2	Average
%	19	23	57	1.4

compound A – ethene

compound B – propanoic acid

Students were required to name two of the compounds for which they had given semi-structural formulas in Question 6b. The stronger overall performance compared to 6b. can be attributed, in part, to the allocation of consequential marks, i.e. if the formula given in 6b. was inappropriate for the pathway but the name provided in 6c. was consistent with that, formula marks were awarded. There were also instances where chemical formulas given in 6b. were inaccurate, but the names given in 6c. were consistent with the intended reaction pathway.

The rules for systematic naming were generally well applied. Students should be aware that numbers are included in the names only when necessary. Straight chain saturated alkanolic acids do not have a number for the  $-\text{COOH}$  group because it is always C-1.

## Question 6d.

Marks	0	1	Average
%	44	56	0.6

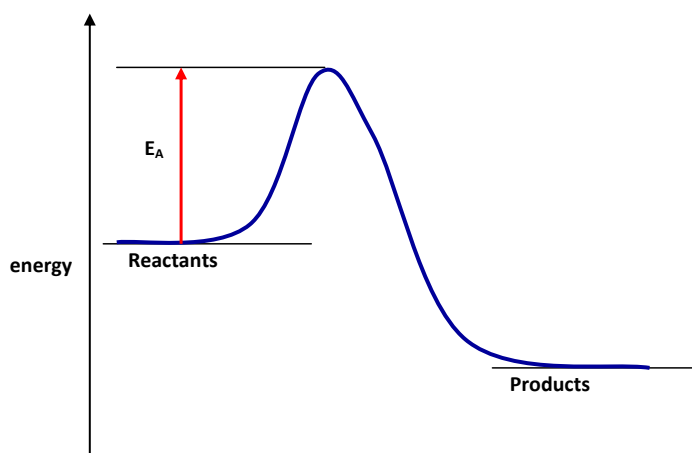

Many students handled this question well. A number of students produced the profile for an endothermic reaction, even though the question specified combustion. Poor labelling of the profile was the main error.

## Question 7a.

Marks	0	1	Average
%	39	61	0.6

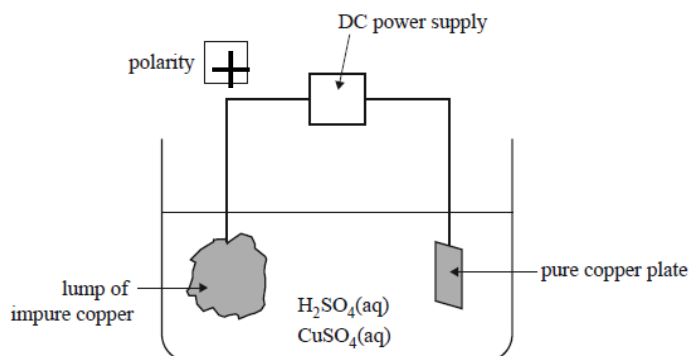

# 2013 Examination Report



The purified copper is deposited on the pure copper plate via  $\text{Cu}^{2+}(\text{aq}) + 2\text{e}^{-} \rightarrow \text{Cu}(\text{s})$  at the cathode. The impure copper is extracted into solution from the lump of impure copper via  $\text{Cu}(\text{s}) \rightarrow \text{Cu}^{2+}(\text{aq}) + 2\text{e}^{-}$  at the anode. In an electrolytic cell, electrons are forced to move from the (+) electrode to the (-) electrode.

## Question 7b.

Marks	0	1	2	3	4	Average
%	24	18	32	21	5	1.7

$$\begin{aligned} \text{Change in mass of impure electrode} &= 10.30 - 0.855 \\ &= 9.445 \text{ kg} \end{aligned}$$

$$\begin{aligned} \text{Change in mass of pure electrode} &= 9.80 - 1.55 \\ &= 8.25 \text{ kg} \end{aligned}$$

$$\begin{aligned} \% \text{ purity of impure copper} &= (\text{m}(\text{Cu}) \text{ deposited on pure plate} / \text{m}(\text{Cu}) \text{ oxidised off lump}) \times 100 \\ &= (8.25 / 9.445) \times 100 \\ &= 87.3 \% \end{aligned}$$

Factors that may affect accuracy include

- electrodes not properly dried before weighing
- not all the Cu produced at the pure copper plate sticks to the copper plate
- the process was not 100 per cent efficient.

One mark each was awarded for

- accurate calculation of change in mass of impure copper electrode
- accurate calculation of change in mass of pure copper electrode
- accurate calculation of percentage purity
- identification of a sensible factor affecting the accuracy of the results.

This question required effective interpretation and use of the data supplied, as well as an understanding of 'percentage purity' in the context of this data. The most common error in the calculations was using the initial mass of the lump of impure copper (10.30 kg) at the point of calculating the percentage purity. This was not appropriate because it assumes that the residual 0.855 kg at the end of the electrolysis did not contain any copper.

Since the lump was impure, the mass lost during electrolysis may be assumed to include both Cu and impurities. However, only Cu is deposited on the pure copper plate. Hence, comparison of the m(Cu) deposited on the pure copper plate with the change in mass of the lump during electrolysis was the key to calculating the percentage by mass of Cu in the lump of impure copper.

Students are reminded that they are expected to be able to apply their chemical knowledge to unfamiliar contexts.

Students were expected to identify a factor specific to this analysis that could produce a variation in the mass of copper, hence general responses such as inaccurate equipment, inconsistent current, not enough time, non-standard conditions, etc. were not acceptable.

## Question 7c.

Marks	0	1	2	3	4	5	Average
%	31	6	9	14	23	18	2.5

$$\begin{aligned} n(\text{Cu}) \text{ deposited} &= 8.25 \times 10^3 / 63.5 \\ &= 130 \text{ mol} \end{aligned}$$

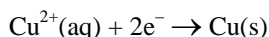

$$\begin{aligned} n(\text{e}^{-}) &= 2 \times 130 \\ &= 260 \text{ mol} \end{aligned}$$

$$\begin{aligned} Q &= 260 \times 96500 \\ &= 2.51 \times 10^7 \text{ C} \end{aligned}$$

$$\begin{aligned} t &= Q/I \\ &= 2.51 \times 10^7 / 24 \\ &= 1.04 \times 10^6 \text{ seconds} \\ &= 1.04 \times 10^6 / (60 \times 60 \times 24) \\ &= 12 \text{ days} \end{aligned}$$

# 2013 Examination Report



One mark each was awarded for

- accurate calculation of  $n(\text{Cu})$
- accurate calculation of  $n(e^-)$
- accurate calculation of charge.

Two marks were awarded for accurately calculating time in days and to two significant figures.

Errors included

- incorrect  $m(\text{Cu})$
- not converting  $m(\text{Cu})$  to grams to calculate  $n(\text{Cu})$
- incorrect calculation of  $n(e^-)$  from  $n(\text{Cu})$
- inaccurate use of the Faraday constant
- inaccuracies in the calculation of time from the current, particularly converting seconds to days. (This was the most common error.)
- not giving the final answer to two significant figures.

Students must ensure that they include appropriate working in calculation questions such as this.

### Question 7d.

Marks	0	1	Average
%	69	31	0.3

- Both  $\text{Ag}^+(\text{aq})$  and  $\text{Au}^+(\text{aq})$  are stronger oxidants than  $\text{Cu}^{2+}(\text{aq})$ .
- $\text{Ag}^+(\text{aq})$  and  $\text{Au}^+(\text{aq})$  would also be reduced at the pure copper plate.
- $\text{Ag}(\text{s})$  and  $\text{Au}(\text{s})$  would also be deposited at the pure copper plate (cathode).

The mass of the pure copper plate would be heavier than it would be if they were not present.

It was clear that many students had accessed the electrochemical series and identified that  $\text{Au}^+(\text{aq})$  and  $\text{Ag}^+(\text{aq})$  are stronger oxidants than  $\text{Cu}^{2+}(\text{aq})$ , but their responses stated that 'silver and gold' are stronger oxidants/'silver and gold' react, rather than the correct 'silver and gold cations'.

### Question 7ei.

Marks	0	1	Average
%	74	26	0.3

UV-visible spectroscopy

The majority of students identified, incorrectly, the technique as atomic absorption spectroscopy (AAS). However, in analysis using AAS, a plot of absorbance versus wavelength is not required because the light sources used in the spectrometer are element specific.

When using UV-visible spectroscopy, a key part of the analysis is determining the wavelength at which the species being analysed, in this case  $\text{Co}^{2+}(\text{aq})$ , absorbs but other species present in the solution do not. Hence, the presence of the absorbance versus wavelength graph in the question information.

Students should consider all the information provided in the question before attempting an answer. The context of the question should also be considered.

### Question 7eii.

Marks	0	1	Average
%	21	79	0.8

510 nm (500–520 was accepted)

This question was well handled. Errors were generally associated with identifying a wavelength for  $\text{Cu}^{2+}$  rather than  $\text{Co}^{2+}$  or stating excessively broad ranges for the wavelength.



# 2013 Examination Report



## Question 7eiii.

Marks	0	1	Average
%	8	92	0.8

0.061 M (0.060–0.062 M was accepted)

## Question 8ai.

Marks	0	1	Average
%	57	43	0.5

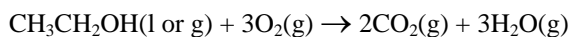

$\text{C}_2\text{H}_5\text{OH}$  and  $\text{C}_2\text{H}_6\text{O}$  were also acceptable for ethanol.

One of the most common errors was the use of (aq) as the state of ethanol. Students are encouraged to consider whether the states used in an equation are logical.

Balancing combustion equations of carbon-based compounds is best done starting with C then H. Count up the total number of 'O' on the product side, subtract for any 'O' in the fuel and then work out the coefficient of  $\text{O}_2$ .

## Question 8aii.

Marks	0	1	2	3	Average
%	14	12	24	51	2.1

$$\begin{aligned}n(\text{CH}_3\text{CH}_2\text{OH}) &= 5.85/46.0 \\ &= 0.127 \text{ mol}\end{aligned}$$

$$\begin{aligned}n(\text{O}_2) &= 14.2/32.0 \\ &= 0.444 \text{ mol}\end{aligned}$$

Since  $\text{CH}_3\text{CH}_2\text{OH}$  and  $\text{O}_2$  react in a 1:3 ratio

$$\begin{aligned}n(\text{O}_2) \text{ required for complete reaction of } \text{CH}_3\text{CH}_2\text{OH} &= 3 \times 0.127 \\ &= 0.382 \text{ mol}\end{aligned}$$

$\text{O}_2$  is in excess by  $0.444 - 0.382 = 0.062 \text{ mol}$

One mark each was awarded for

- accurately calculating  $n(\text{CH}_3\text{CH}_2\text{OH})$  and  $n(\text{O}_2)$
- the number of moles required for complete reaction based on equation ratio
- identifying the excess reagent based on logical data.

Students were expected to make a clear link between the mole amount present and the mole ratio in the equation when determining which reactant was in excess.

There were a variety of valid methods of checking which reactant was in excess. One such method was dividing the mole amounts calculated by the equation coefficients, i.e.  $0.127/1 = 0.127$  for  $\text{CH}_3\text{CH}_2\text{OH}$  and  $0.444/3 = 0.148$  for  $\text{O}_2$ . A direct comparison of these values shows that  $\text{O}_2$  is in excess. However, many who used this method then determined, incorrectly, that the amount in excess was  $0.444 - 0.148 \text{ mol}$  rather than the correct  $0.444 - 3 \times 0.127 \text{ mol}$ .

Students' responses indicated that determination of actual amounts in excess is an area that requires significant improvement. The role of the balanced equation in determining excesses should also be emphasised.

## Question 8b.

Marks	0	1	Average
%	45	55	0.6



Many students were familiar with the equation. 'Fermentation of sugars to produce ethanol' is specifically mentioned in the study design.

# 2013 Examination Report



## Question 8ci.

Marks	0	1	2	3	Average
%	20	14	21	45	1.9

$$n(\text{xylose}) = 1.00 \times 10^3 / 150.0$$

$$= 6.67 \text{ mol}$$

$$n(\text{CH}_3\text{CH}_2\text{OH}) = \frac{5}{3} \times n(\text{xylose})$$

$$= \frac{5}{3} \times 6.67$$

$$= 11.1 \text{ mol}$$

$$m(\text{CH}_3\text{CH}_2\text{OH}) = 11.1 \times 46.0$$

$$= 511 \text{ g}$$

$$\text{Since } d = m/V \rightarrow dV = m \rightarrow V = m / d$$

$$V(\text{CH}_3\text{CH}_2\text{OH}) = 511 \text{ g} / 0.785 \text{ g mL}^{-1}$$

$$= 651 \text{ (mL)}$$

One mark each was awarded for

- accurately calculating  $n(\text{xylose})$
- accurately calculating  $m(\text{ethanol})$  from  $n(\text{xylose})$
- accurately calculating  $V(\text{ethanol})$  in mL.

The most common errors in this question included

- non-conversion of  $m(\text{xylose})$  to grams to calculate  $n(\text{xylose})$
- incorrect mol ratio used to determine  $n(\text{ethanol})$  from  $n(\text{xylose})$
- not calculating  $m(\text{ethanol})$
- incorrect use of the density of ethanol.

## Question 8cii.

Marks	0	1	2	Average
%	28	23	50	1.2

$$V(\text{CO}_2) = I(\text{CO}_2) \times RT/p$$

$$p(\text{CO}_2) = 750.0 \text{ mm Hg}$$

$$= (750.0/760) \times 101.3 \text{ kPa}$$

$$= 99.97 \text{ kPa}$$

$$n(\text{CO}_2) = n(\text{CH}_3\text{CH}_2\text{OH}) = 11.1 \text{ mol}$$

$$V(\text{CO}_2) = 11.1 \times 8.31 \times 293.0 / 99.97$$

$$= 271 \text{ L}$$

One mark each was awarded for

- accurately substituting data into  $pV = nRT$  using appropriate units
- accurately calculating  $V(\text{CO}_2)$  from substituted data and including correct units in answer.

There was a clear distinction between those students who could convert 750 mm Hg to kPa and those who could not.

Students should be aware that when the general gas equation is used with the gas constant,  $R$ , equal to 8.31, and pressure in kPa, the volume unit is litres.

# 2013 Examination Report



## Question 9a.

Marks	0	1	2	3	4	5	6	Average
%	12	5	9	9	16	15	36	4

### Mass spectrum

Either of

- the parent (molecular) ion peak at  $m/z = 88$  is consistent with the molar mass (relative molecular) mass of ethyl ethanoate ( $\text{CH}_3\text{COOCH}_2\text{CH}_3$ )
- other peaks on the spectrum are consistent with fragments that may result from ethyl ethanoate ( $\text{CH}_3\text{COOCH}_2\text{CH}_3$ ), for example

$m/z = 15$ :  $[\text{CH}_3]^+$

$m/z = 29$ :  $[\text{CH}_3\text{CH}_2]^+$

$m/z = 43$ :  $[\text{CH}_3\text{CO}]^+$

$m/z = 45$ :  $[\text{CH}_3\text{CH}_2\text{O}]^+$

$m/z = 70$ :  $[\text{CH}_2\text{COOC}]^+$

$m/z = 73$ :  $[\text{CH}_3\text{COOCH}_2]^+$

Two marks were awarded for relating  $m/z$  ratio of parent ion peak to the molar mass of ethyl ethanoate or for giving the formula of one fragment identified with ethyl ethanoate based on the  $m/z$  ratio on the mass spectrum.

### Infrared spectrum

Either of

- strong absorption around  $1750\text{ cm}^{-1}$  (in the  $1670\text{--}1750$  band) is consistent with the present of  $\text{C}=\text{O}$ . This bond is present in ethyl ethanoate,  $\text{CH}_3\text{COOCH}_2\text{CH}_3$
- absence of broad peak in the  $2500\text{--}3300\text{ cm}^{-1}$  absorption band shows that  $\text{O}\text{--}\text{H}$  (acids) bond is not present and so the compound cannot be a carboxylic acid with four C atoms.

Two marks were awarded for explaining how the spectrum shows that  $\text{C}=\text{O}$  is present or for explaining how the spectrum shows that  $\text{O}\text{--}\text{H}$ (acid) is not present.

### $^1\text{H}$ NMR spectrum

One of

- the three different sets of peaks mean/indicate that  $\text{CH}_3\text{COOCH}_2\text{CH}_3$  has three different hydrogen environments
- the triplet and quartet on the spectrum are consistent with the presence of an ethyl group  $\text{--CH}_2\text{CH}_3$  in  $\text{CH}_3\text{COOCH}_2\text{CH}_3$
- chemical shifts,  $\delta=4.1$  ( $\text{RCOOCH}_2\text{R}$ )/ $\delta = 2.0$  ppm  $\text{CH}_3\text{COOR}$  are characteristic of an ester.

Two marks were awarded for linking three different sets of peaks to the three different hydrogen environments in  $\text{CH}_3\text{COOCH}_2\text{CH}_3$ , linking the quartet and triplet on the spectrum to the presence of an ethyl group,  $\text{CH}_3\text{CH}_2$ , or for indicating how the chemical shift at either  $\delta=4.1$  ppm or  $2.0$  ppm is consistent with the structure of ethyl ethanoate  $\text{CH}_3\text{COOCH}_2\text{CH}_3$ .

## Question 9b.

Marks	0	1	Average
%	68	32	0.3

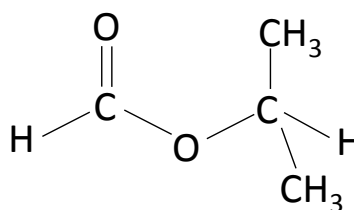
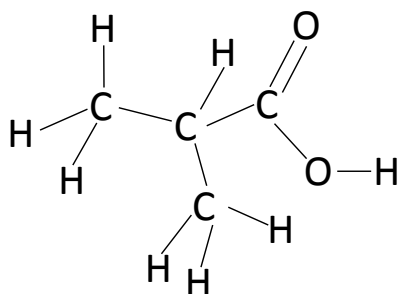

# 2013 Examination Report



Many students struggled to produce a structure of an alternative compound with the same molecular formula as ethyl ethanoate that had three different carbon environments. While any structure that met these requirements was acceptable when considering structural isomers of an ester with four C atoms, students should have first considered other esters or carboxylic acids with four C atoms. There are, for example, two carboxylic acids, butanoic acid,  $\text{CH}_3\text{CH}_2\text{CH}_2\text{COOH}$ , and methylpropanoic acid,  $(\text{CH}_3)_2\text{CHCOOH}$ . However, only methyl propanoic acid has three carbon environments.

## Question 10ai.

Marks	0	1	Average
%	61	39	0.4

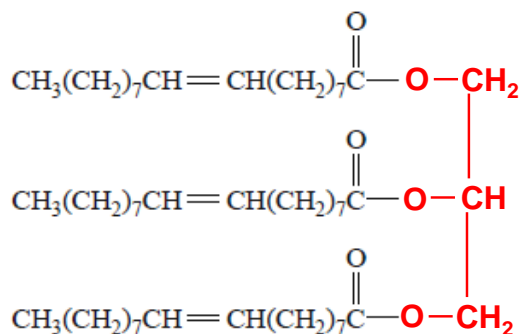

This question proved more challenging than might have been expected, given that the structure of glycerol was given in Table 12 in the Data Book. Students should be aware that triglycerides (fats) are formed by reaction between fatty acids and glycerol and in that reaction the carboxyl,  $-\text{COOH}$ , group on each of the three fatty acid molecules reacts with one of the three hydroxyl,  $-\text{OH}$ , groups on glycerol to produce three ester,  $-\text{COO}-$ , groups in each triglyceride molecule.

## Question 10aii.

Marks	0	1	Average
%	60	40	0.4

Each molecule contains one  $\text{C}=\text{C}$ , carbon-carbon double bond.

This question emphasised the importance of accurate description. Most responses simply stated 'one double bond'; however, this was not accepted because all fatty acids, saturated and unsaturated, contain at least one double bond – the  $\text{C}=\text{O}$  double bond in the carboxylic group. So, the distinction between saturated fatty acids and unsaturated fatty acids is made on the number of carbon-carbon double bonds, i.e.  $\text{C}=\text{C}$ , present.

## Question 10b.

There was significant confusion in responses to this question, in many cases caused by students progressing further than necessary in Question 10bi. Students should be aware that combustion reactions are exothermic, hence  $\Delta H$  will have a negative sign along with the units  $\text{kJ mol}^{-1}$ .

## Question 10bi.

Marks	0	1	2	Average
%	28	15	57	1.3

$$\Delta T = 22.4 - 20.0 = 2.4^\circ$$

$$\text{Energy released} = 9112 \times 2.4$$

$$= 2.2 \times 10^4 \text{ J or } 22 \text{ kJ}$$

# 2013 Examination Report



One mark each was awarded for accurately calculated energy and for units consistent with calculated amount of energy. Errors on this question were associated with incorrect or no units and inaccurate use of the temperature change. A number of students went beyond the necessary calculation to work out energy per mole. The problem with proceeding with unnecessary calculation is that errors can lead to the contradiction of a previously correct answer.

## Question 10bii.

Marks	0	1	2	Average
%	30	19	52	1.2

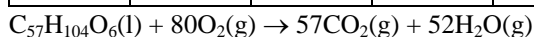

One mark was awarded for the correct formula for each of the reactants and products, and one mark for a correctly balanced equation.

A higher percentage of students received full marks for this combustion equation than for the combustion of ethanol in Question 8ai. Students should think about the states they use in equations.

A number of students did not use the formula of glycerol trioleate.

There were some instances of incorrect coefficients for  $\text{O}_2$ , usually as a result of not allowing for the O atoms in the oil.

## Question 10biii.

Marks	0	1	2	Average
%	52	27	22	0.7

$$n(\text{olive oil}) = 1.00/884$$

$$= 1.13 \times 10^{-3} \text{ mol}$$

$$\text{Energy released per mol} = 22 \text{ kJ}/1.13 \times 10^{-3} \text{ mol} \text{ or } 22 \text{ kJ g}^{-1} \times 884 \text{ g mol}^{-1}$$

$$= 1.9 \times 10^4 \text{ kJ mol}^{-1}$$

$$\Delta H = -1.9 \times 10^4 \text{ kJ mol}^{-1} / \Delta H = -1.9 \times 10^7 \text{ J mol}^{-1} / \Delta H = -19 \text{ MJ mol}^{-1}$$

One mark each was awarded for

- accurately calculated energy for 1 mol of olive oil
- negative sign and units.

## Question 11a.

Marks	0	1	Average
%	44	56	0.6

a.: a catalyst increases the rate of reaction, and c.: the mass of a catalyst is the same before and after the reaction

The number of students who did not select statement a. – a catalyst increases the rate of a reaction – as a correct statement was surprising.

Statement F – all catalysts align the reactant particles in an orientation that is favourable for a reaction to occur – was a relatively frequent choice, perhaps indicating that students were thinking of enzymes specifically rather than the broad spectrum of catalysts.

# 2013 Examination Report



## Question 11b.

Marks	0	1	2	3	4	5	6	Average
%	7	9	18	25	24	13	4	3.1

a. all catalysts are solid.	Catalysts can be solids, liquids, gases or aqueous solutions; for example, sulfuric acid/enzymes/ $H_3PO_4$ , etc.
b. a catalyst lowers the enthalpy change of a reaction, enabling more particles to have sufficient energy to successfully react.	A catalyst does not change the relative energy contents of reactants and products. It does, however, lower the activation energy/increases the proportion of successful collisions/provides an alternative reaction pathway with the same overall $\Delta H$
e. a catalyst increases the value of the equilibrium constant, thus favouring the extent of the forward reaction, resulting in a greater yield of product.	A catalyst does not affect relative amounts of reactants and products at equilibrium (position of equilibrium/extent of reaction)/only a change in temperature changes the value of the equilibrium constant. A catalyst increases the rates of forward and reverse reactions equally/gets the system to equilibrium faster.
f. all catalysts align the reactant particles in an orientation that is favourable for a reaction to occur.	Enzymes/solid catalysts align (arrange) reactant particles into orientations that favour reaction. However, liquid catalysts and gaseous catalysts do not arrange reactants in this way.
g. the effectiveness of a metal catalyst is not dependent upon its surface area.	Reaction occurs on the catalyst surface. The larger the surface, the more 'effective' the catalyst.
h. enzymes are biological catalysts that catalyse a specific biochemical reaction once only.	Enzymes continue to catalyse specific chemical reactions because they are not consumed in the reactions. The tertiary structure/active site is not changed as a result of the reaction.
i. the effectiveness of an enzyme is independent of temperature.	Enzyme effectiveness depends on the shape of the active site /Enzymes have an optimum operating temperature. At high temperatures the active site is denatured (changes shape).

A significant number of students made only one relatively definitive statement as to why each of their chosen alternatives was an invalid statement about catalysts.

The most commonly identify invalid statements were B, D, E and I.

- For statement B, while most accessed one of the marks for other states for catalysts, most did not give a supporting example.
- For statement D, most mentioned the lowering of the activation energy but did not explain why the  $\Delta H$  does not change, i.e. no effect on the relative energies of the reactants and products.
- For statement E, some students covered the effect on reaction rate, but did not explain why the value of K does not change. A significant number made the point that only a change in temperature changes the value of K.
- Statement I was probably handled the best, with two of the following three points made: optimum operating temperature, denaturation at high temperature and shape as a key factor in enzyme effectiveness.