

**THE
HEFFERNAN
GROUP**

P.O. Box 1180
Surrey Hills North VIC 3127
ABN 20 607 374 020
Phone 9836 5021
Fax 9836 5025

Student Name.....

FURTHER MATHEMATICS
TRIAL EXAMINATION 1
(FACTS, SKILLS AND APPLICATIONS)

2001

Reading Time: 15 minutes
Writing time: 90 minutes

Instructions to students

This exam consists of section A and Section B.
Section A contains 13 multiple-choice questions from the core, "Data Analysis".
Section A is compulsory and is worth 13 marks.
Section B consists of 5 modules each containing 9 multiple-choice questions. You should choose 3 of these modules and answer every question in each of your chosen modules.
Each of the modules is worth 9 marks.
Section B begins on page 9 of this exam.
There is a total of 40 marks available for this exam.
Students may bring up to two A4 pages of pre-written notes into the exam.
An answer sheet appears on page 32 of this exam.

This paper has been prepared independently of the Victorian Curriculum and Assessment Authority to provide additional exam preparation for students. Although references have been reproduced with permission of the Victorian Curriculum and Assessment Authority, the publication is in no way connected with or endorsed by the Victorian Curriculum and Assessment Authority.

© THE HEFFERNAN GROUP 2001

This Trial Exam is licensed on a non transferable basis to the purchaser. It may be copied for educational use within the school which has purchased it. This license does not permit distribution or copying of this Trial Exam outside that school or by any individual purchaser.

Section A

Section A consists of 13 questions. Answer every question in Section A.

Core

The follow information relates to Questions 1 and 2.

The profit made by a contractor on each of his last 50 jobs is summarized in the histogram below.

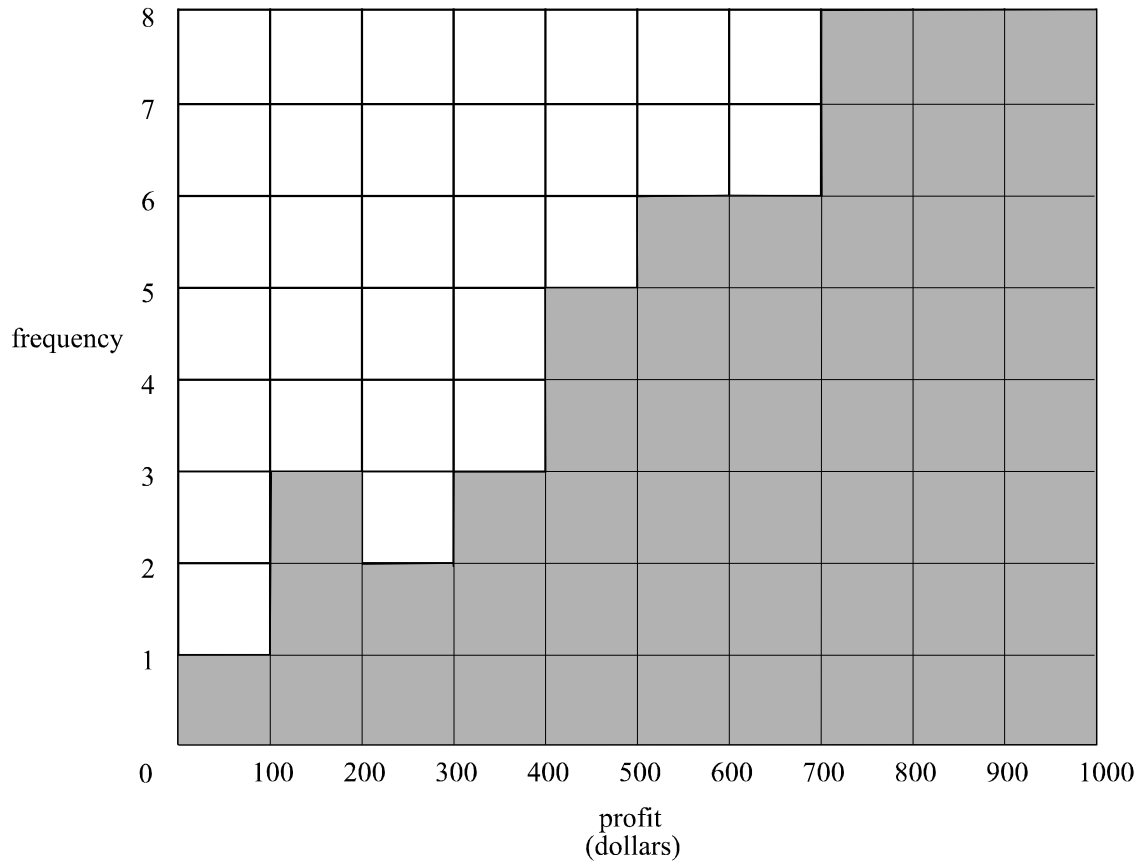

Question 1

The percentage of jobs on which the contractor made a profit of less than \$400 is

- A. 3%
- B. 5%
- C. 6%
- D. 9%
- E. 18%

Question 2

The distribution of profits

- A. is negatively skewed
- B. is positively skewed
- C. is symmetric
- D. is discrete
- E. has outliers

The information below relates to Questions 3 and 4.

A shopkeeper considers whether it is worth trading on Sundays. He records the number of transactions made on Saturdays and Sundays over a long period. That data is displayed in the parallel boxplots shown below.

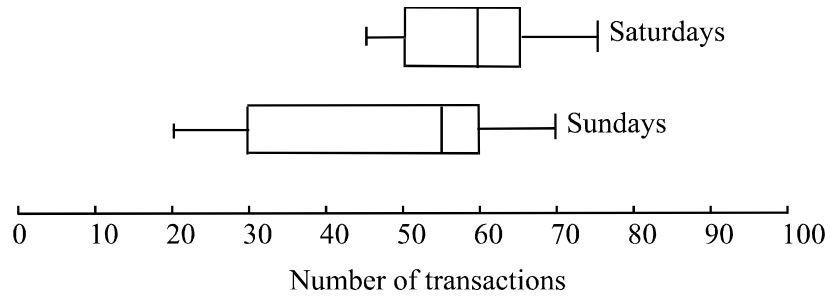

Question 3

The difference between the interquartile ranges of the distributions is

- A. 5
- B. 10
- C. 15
- D. 20
- E. 25

Question 4

From these boxplots, it can be concluded that the number of transactions on a Sunday is

- A. about the same as the number made on a Saturday
- B. more variable and usually higher than on a Saturday
- C. more variable and usually lower than on a Saturday
- D. less variable and usually higher than on a Saturday
- E. less variable

Question 5

The distribution of the weight of packets of 'Sonice' rice cracker biscuits is bell shaped with a mean of 100g and a standard deviation of 1.5g.

The percentage of packets of Sonice rice cracker biscuits which weigh more than 101.5g is closest to

- A. 16%
- B. 32%
- C. 34%
- D. 68%
- E. 95%

Question 6

The segmented bar chart below shows the distribution of the number of days in a week alcohol is consumed according to age group for a random sample of people in a large organization.

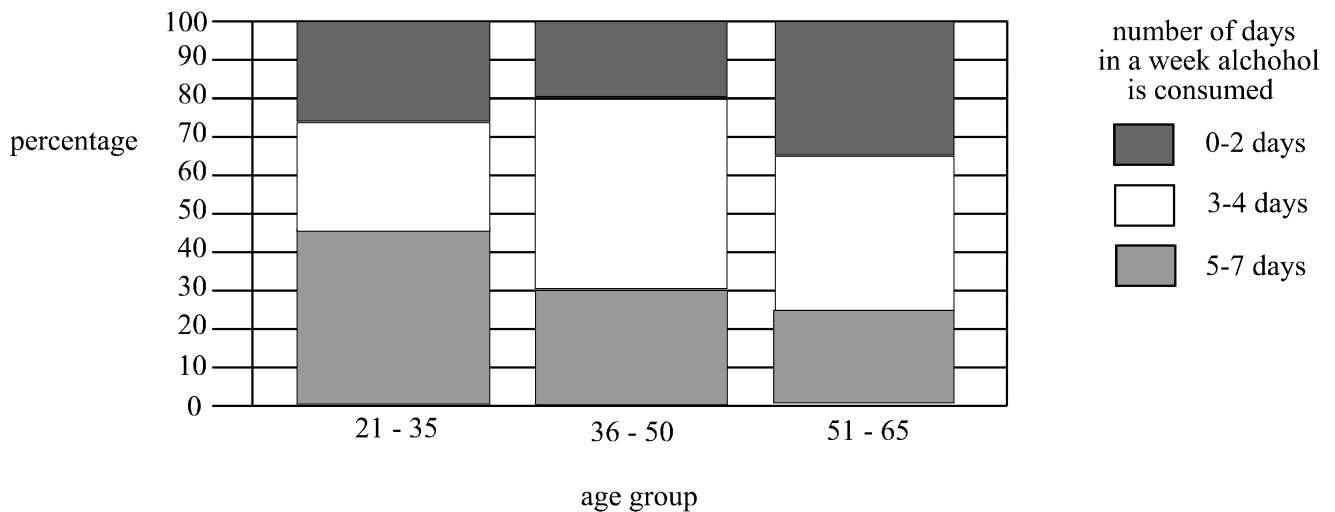

For those sampled, the percentage in the 51–65 age group who drink 3–4 days in a week is

- A. 25
- B. 30
- C. 40
- D. 50
- E. 65

The following information relates to questions 7 and 8.

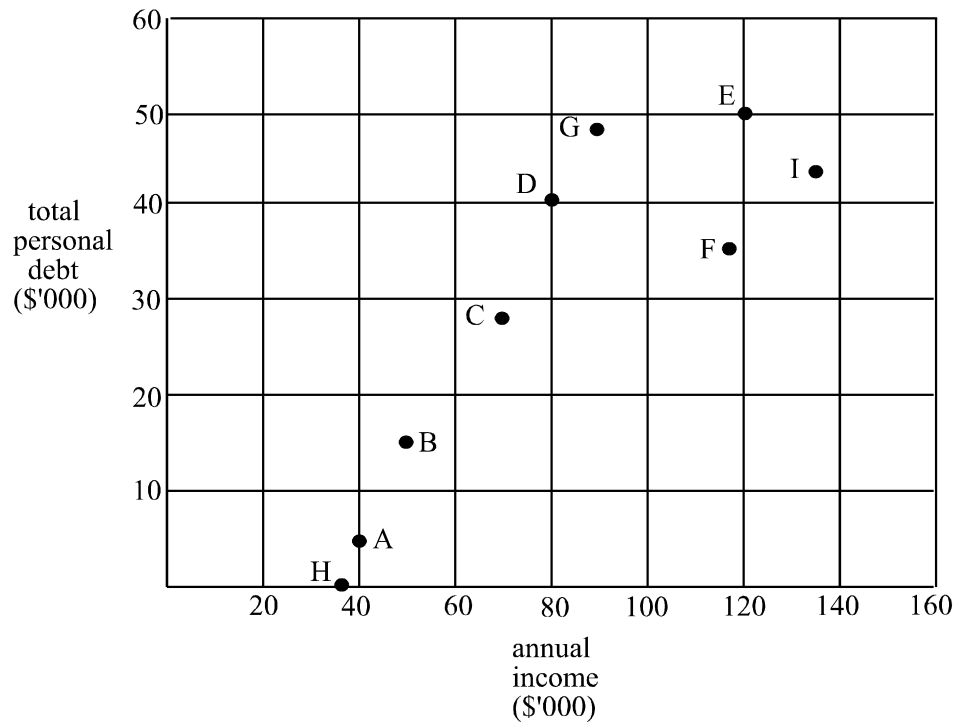

The scatterplot above shows the total personal debt, in thousands of dollars, against annual income, in thousands of dollars, for 9 men.

Question 7

If a three median line were fitted to this data, it would pass through the points

- A. A and E
- B. A and F
- C. B and E
- D. B and F
- E. C and D

Question 8

A reasonable estimation of the product moment correlation coefficient r , for this data would be

- A. -0.9
- B. -0.1
- C. 0
- D. 0.4
- E. 0.8

Question 9

A regression line is fitted by eye to a set of bivariate data shown on the scatterplot below.

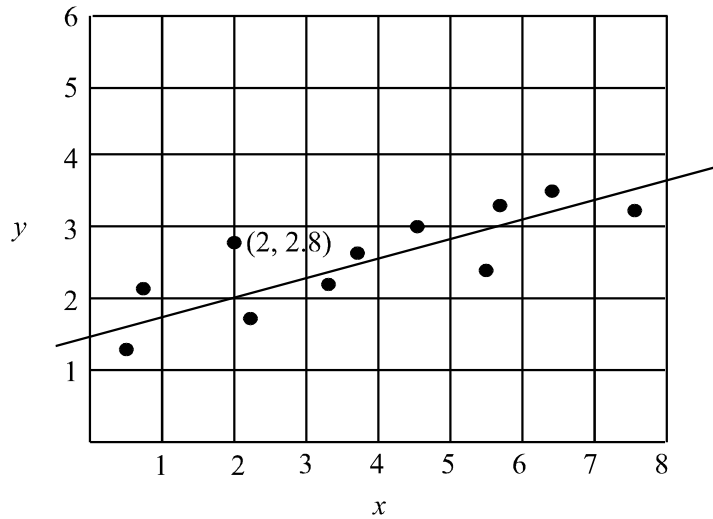

The residual value of the data point $(2, 2.8)$ is

- A. 0.2
- B. 0.8
- C. 1
- D. 2
- E. 2.8

Question 10

The non-linear relationship between two variables x and y is shown on the scatterplot below.

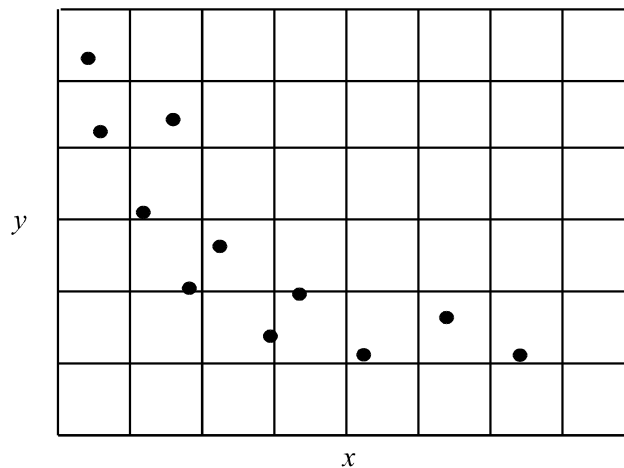

In an attempt to linearise the data, a student would be best advised to

- A. calculate r
- B. draw a line of best fit
- C. use an x^2 transformation
- D. use a $\log x$ transformation
- E. use a y^2 transformation

Question 11

A company's fertilizer sales for 2000-2001, together with their seasonal indices for summer, autumn and winter are shown in the table below.

	summer	autumn	winter	spring
fertilizer (tonnes)	223	211	198	
seasonal index	0.83	0.78	0.85	1.54

Given that the deseasonalised value of the amount of fertilizer sold in spring is 242 tonnes, then the amount of fertilizer sold, in tonnes, in spring is closest to

- A. 61
- B. 157
- C. 206
- D. 268
- E. 373

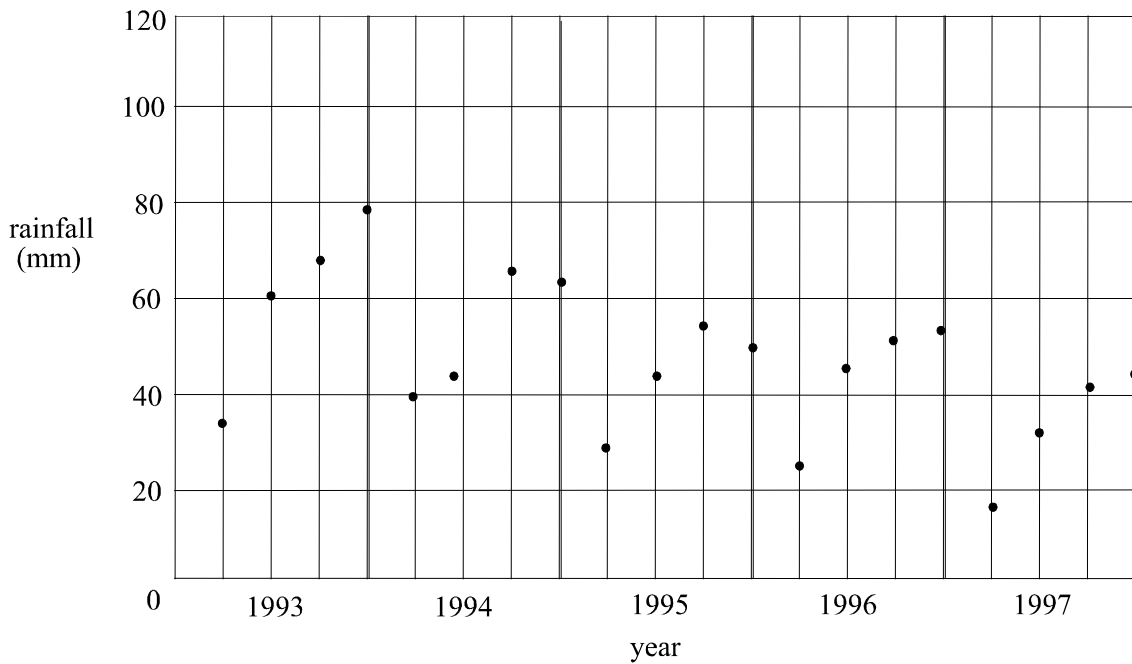
Question 12

The time series plot above is best described as

- A. cyclic
- B. seasonal
- C. trending downwards
- D. seasonal and trending downwards
- E. cyclic and trending downwards

Question 13

The number of new enrolments each month in a gym class at the local gymnasium is shown below for the first half of the year.

month	number of new enrolments
January	22
February	16
March	20
April	14
May	16
June	10

Using smoothing with a 4-moving median with centring, the smoothed number of new enrolments for April is

- A. 15
- B. 15.5
- C. 16
- D. 16.5
- E. 17

Section B

Section B consists of 5 modules and each module contains 9 questions.
You should select **3** modules only and answer **all** questions in each of those 3 modules.

Module 1 : Number patterns and applications

If you choose this module, **all** questions are to be answered.

Question 1

If the ratio of girls to boys at a childcare centre is 2 : 3 then the percentage of girls at the centre is

- A. 15%
- B. 20%
- C. 40%
- D. 55%
- E. 67%

Question 2

The sum of the first 15 terms of the arithmetic sequence

$$\frac{1}{2}, 2, 3\frac{1}{2}, 5, \dots$$

is

- A. 63.75
- B. 75
- C. 165
- D. 330
- E. 436.9

Question 3

The sum of the infinite geometric sequence

$$6, 2, \frac{2}{3}, \frac{2}{9}, \dots$$

is

- A. 5.7
- B. 7.3
- C. 8
- D. 9
- E. 12

Question 4

The sequence of terms generated by the difference equation

$$t_{n+1} = t_n - 3 \quad \text{where } t_1 = 5$$

could also be generated by

- A. $t_n = -3n + 8$
- B. $t_n = 5n - 3$
- C. $t_n = n - 3$
- D. $t_n = n + 2$
- E. $t_n = n + 5$

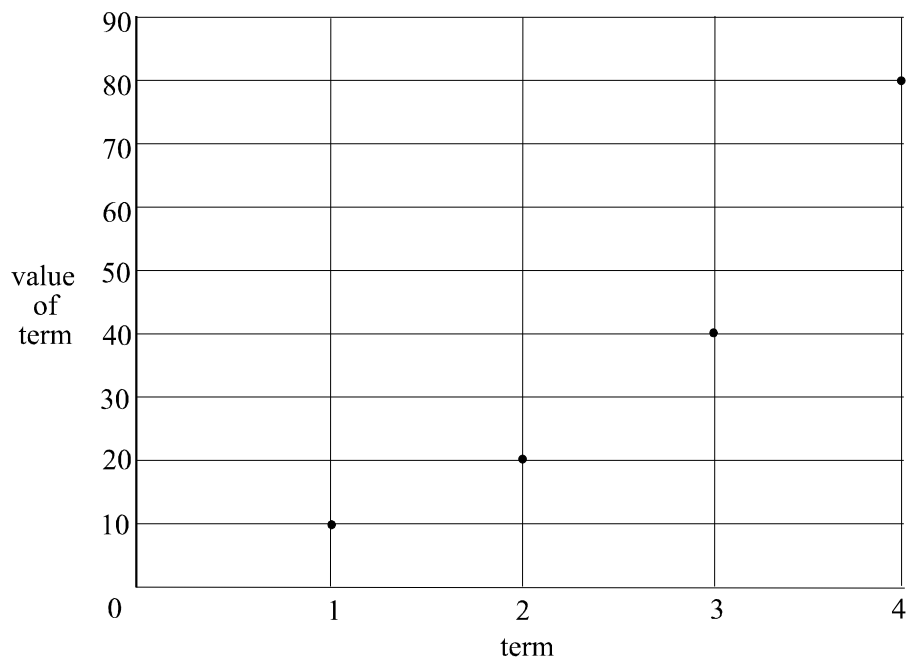
Question 5

The sequence shown on the graph above could be defined by which **one** of the following?

- A. $t_{n+1} = t_n + 2$ where $t_1 = 10$
- B. $t_{n+1} = 2t_n$ where $t_1 = 10$
- C. $t_n = n + 10$
- D. $t_n = 2n$
- E. $t_n = 2 \times 10^{n-1}$

Question 6

The difference equation

$$t_{n+1} = 3t_n + 1 \quad \text{where } t_1 = -4$$

defines a sequence which could be described as

- A. increasing
- B. increasing and arithmetic
- C. decreasing
- D. decreasing and arithmetic
- E. decreasing and geometric

Question 7

Two brothers have a map with a scale of 1 : 15 000. On the map, the distance between two points of interest is 40 mm. If the brothers walk from one of these points of interest directly to the other, what distance will they each have covered?

- A. 6 cm
- B. 6 m
- C. 60 m
- D. 0.6 km
- E. 6 km

Question 8

Paul invests \$20 000 on the 1st of April 2001 in a savings investment account which earns 4% annual interest. Interest is calculated on the account on the 31st March each year and is reinvested in the account. Paul always adds, at the same time as the interest is being reinvested, a sum of \$3000 to the account.

If A_{n+1} is the amount in the account at the start of the $(n+1)$ th year, then the amount of money in Paul's account on 1st April each year could be described by the difference equation

- A. $A_{n+1} = 1.04A_n + 3000$ where $A_1 = 20\,000$
- B. $A_{n+1} = 1.04(A_n + 3000)$ where $A_1 = 20\,000$
- C. $A_{n+1} = 1.4(A_n + 3000)$ where $A_1 = 20\,000$
- D. $A_{n+1} = 0.04A_n + 3000$ where $A_1 = 20\,000$
- E. $A_{n+1} = 0.04(A_n + 3000)$ where $A_1 = 20\,000$

Question 9

Mrs. Davidson received a pension of \$12 000 in the first year and the pension increases by 3% in each subsequent year. What was the total amount of pension received by Mrs. Davidson over the first 10 years?

- A. \$120 046.35
- B. \$123 600.00
- C. \$128 742.11
- D. \$137 566.55
- E. \$142 642.30

Module 2 : Geometry and trigonometry

 If you choose this module, **all** questions are to be answered.

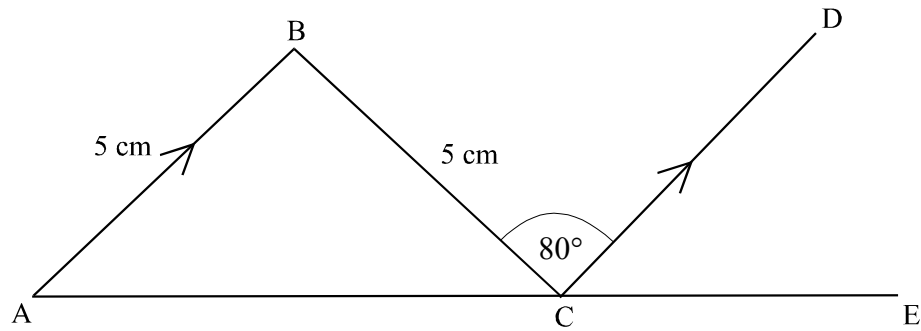
Question 1

In the diagram above, AB is parallel to CD .

In $\triangle ABC$, $\angle BAC$ is equal to

- A. 40°
- B. 50°
- C. 60°
- D. 80°
- E. 100°

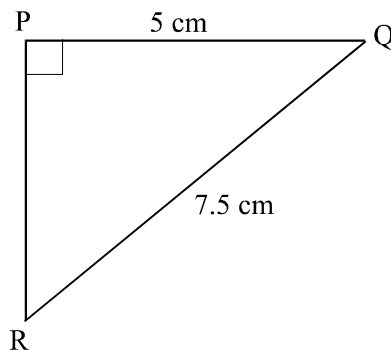
Question 2

In $\triangle PQR$, the size of $\angle PRQ$ is closest to

- A. 28°
- B. 34°
- C. 37°
- D. 42°
- E. 48°

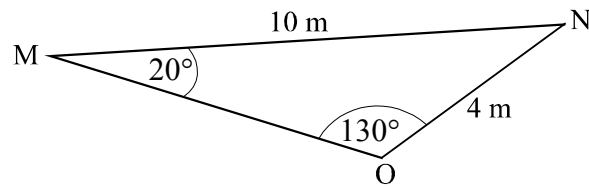
Question 3

The area, in square metres, of $\triangle MNO$ shown above, is

- A. 6.8
- B. 10
- C. 15.3
- D. 20
- E. 30.6

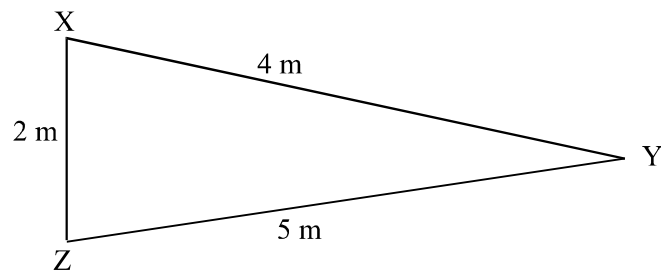
Question 4

In $\triangle XYZ$, the angle XYZ is closest to

- A. 22°
- B. 27°
- C. 31°
- D. 33°
- E. 57°

Question 5

The ratio of the radius of two spheres is 1 : 4.

If the volume of the smaller sphere is 2304π cubic metres, then the volume of the larger sphere in cubic metres is

- A. 9216
- B. 9216π
- C. 36864
- D. 36864π
- E. 147456π

Question 6

The contour map shown below forms part of a larger contour map which has a scale of 1 : 20 000.

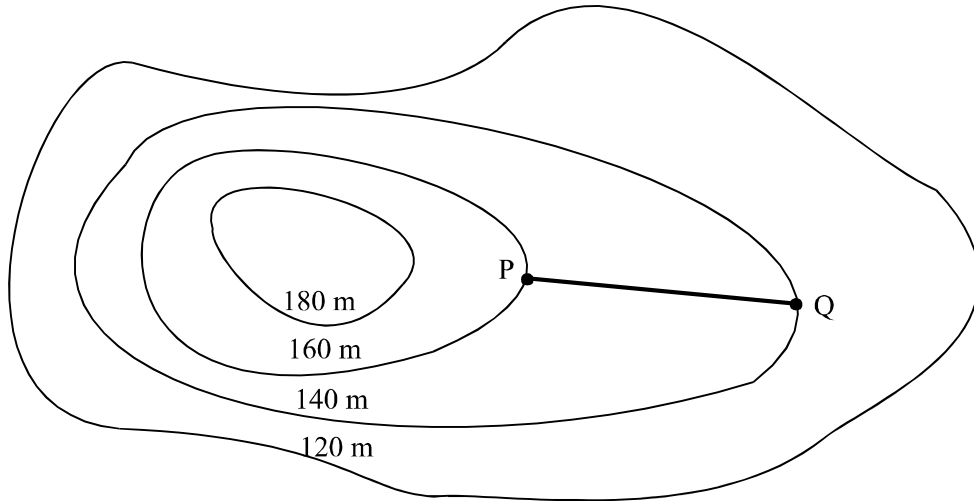

The distance between the points P and Q on the contour map is 10 mm.
The average slope of the line joining points P and Q is

- A. 0.0005
- B. 0.1
- C. 10
- D. 50
- E. 199

Question 7

Part of a surveyors sketch from a traverse survey is shown below.

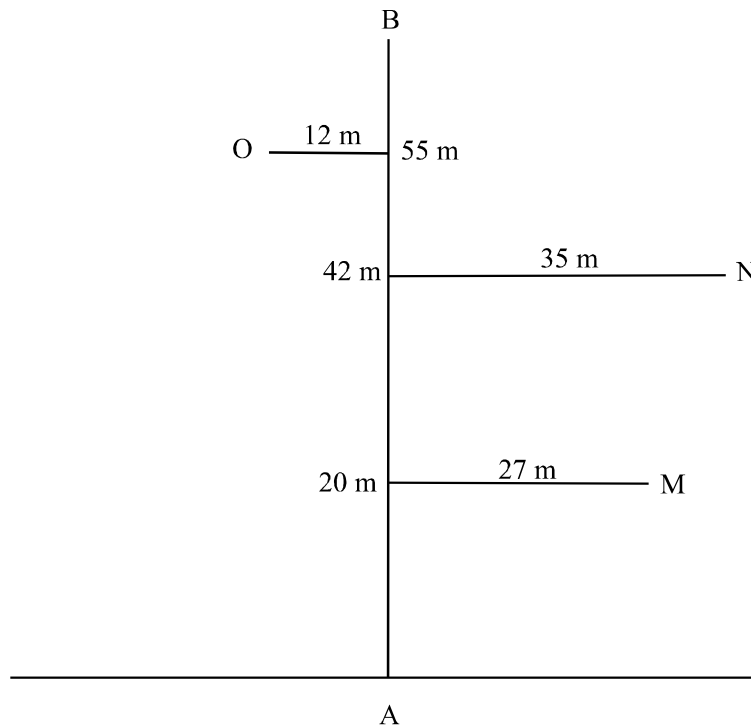

The measurements beside the points on the line AB represent distances from point A which is on the base line.

The perpendicular offset distances of the points of interest at M, N and O are indicated on the diagram.

The actual distance from M to N, in metres, correct to 1 decimal place, is

- A. 20.5
- B. 23.4
- C. 32.7
- D. 37.9
- E. 42.8

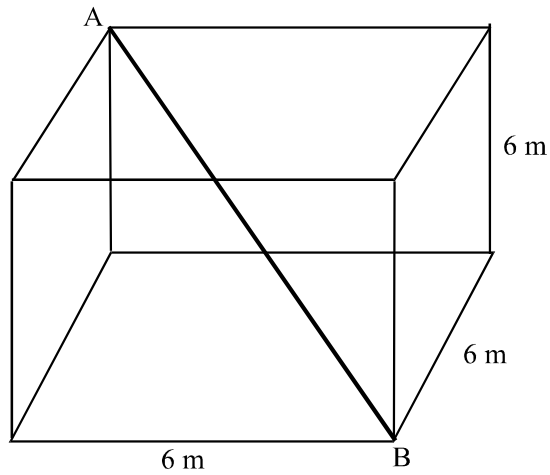
Question 8

The cube shown above has sidelengths of 6 metres.
The length of the diagonal AB, in metres, is closest to

- A. 6
- B. 8.5
- C. 10.4
- D. 11.3
- E. 12

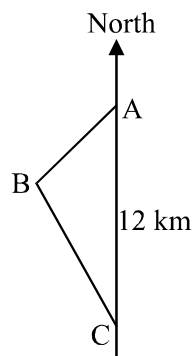
Question 9

Point A is 12 km due north of point C. Point B has a true bearing of 330° from point C and point A has a true bearing of 050° from point B.
The distance from B to C in km is closest to

- A. 6.8
- B. 7.8
- C. 9.3
- D. 14.7
- E. 15.4

Module 3 : Graphs and relations

If you choose this module, **all** questions should be answered.

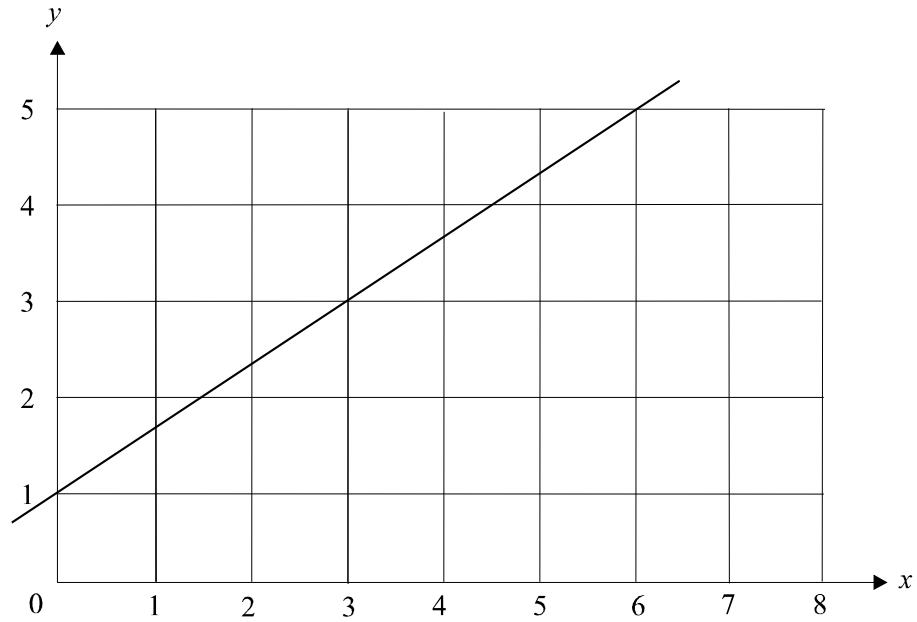
Question 1

The equation of the line shown on the graph above is

- A. $y = x + 1$
- B. $y = 6x + 1$
- C. $3y = 2x + 1$
- D. $y + 6x = 1$
- E. $3y - 2x = 3$

Question 2

The graph below shows the temperature, in degrees Celsius, recorded over a 24 hour period at a recording station inside the Arctic circle.

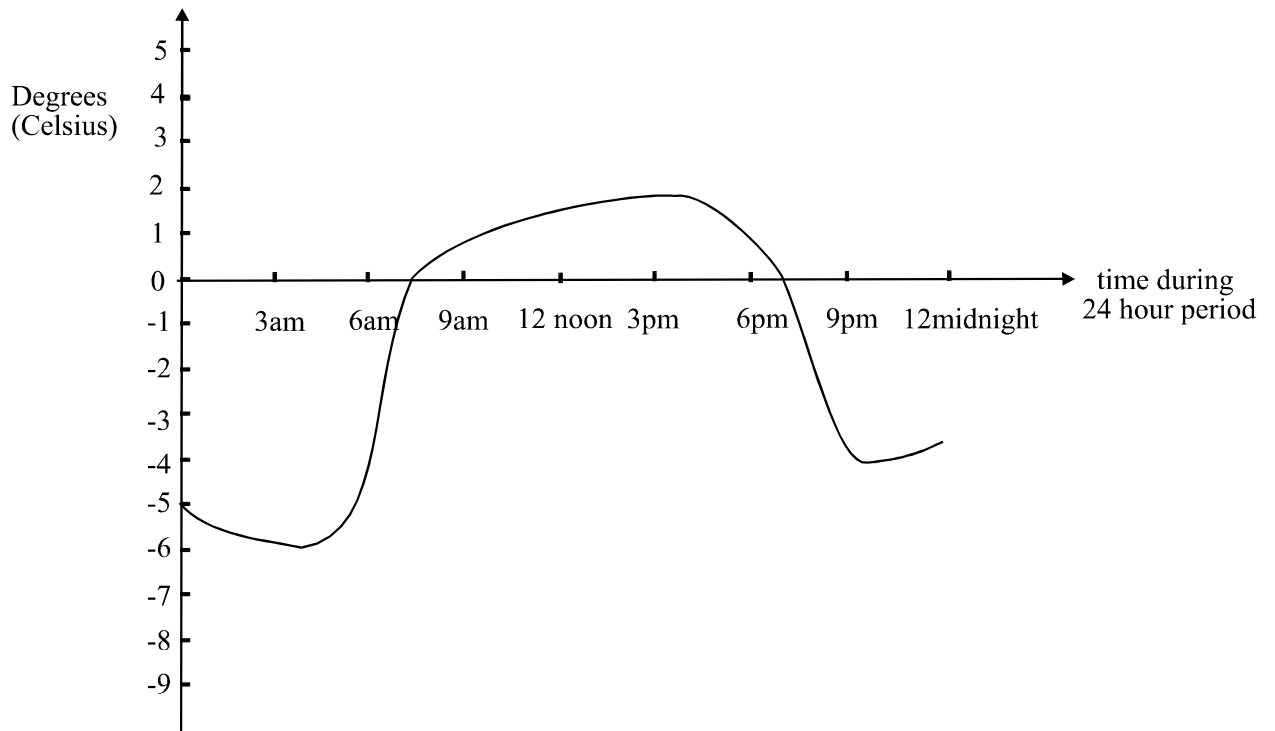

During this 24 hour period, the temperature was 0°

- A. on no occasions
- B. once
- C. twice
- D. three times
- E. four times

Question 3

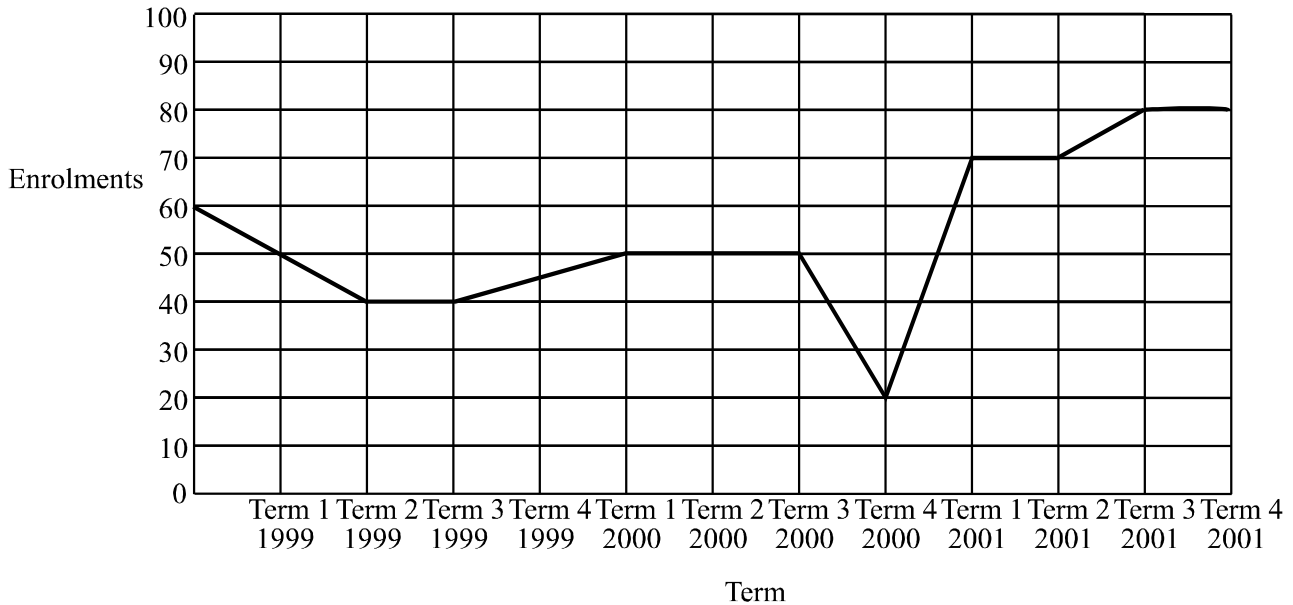

The number of students enrolled at a yoga school is recorded each term. The enrolments for 1999, 2000 and 2001 are shown above.

Which one of the following statements is **not** true?

- A. The greatest decline in enrolments occurred between term 3 2000 and term 4 2000.
- B. The longest period that enrolments remained constant for was 2 terms.
- C. The greatest increase in enrolments occurred between term 4 2000 and term 1 2001.
- D. Enrolments over the 3 year period ended higher than they began.
- E. Enrolments did not decrease at all during 2001.

Question 4

The revenue, R , in dollars, of the POQ courier company is given by $R = 15x$, where x is the number of deliveries made.

The cost, C , in dollars, of making the deliveries, is given by $C = 5x + 3000$.

The number of deliveries that the POQ courier company need to make to break even is

- A. 150
- B. 300
- C. 1500
- D. 3000
- E. 4500

Question 5

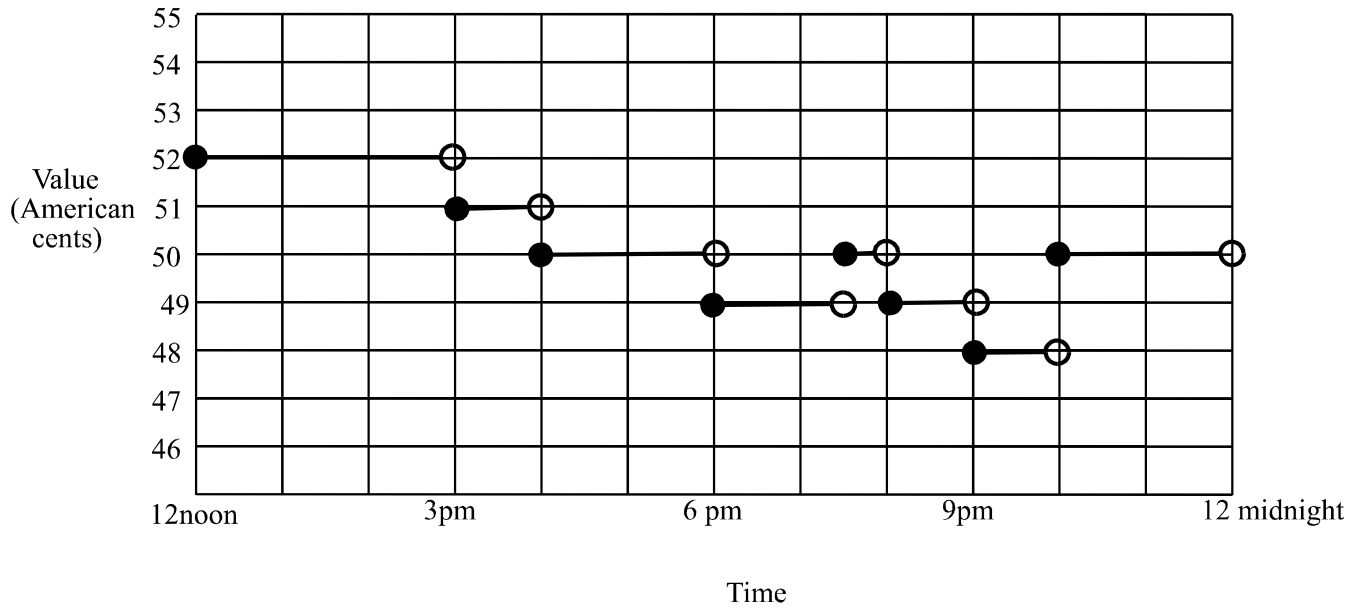

The value of the Australian dollar, expressed in terms of U.S. cents, was monitored over a 12 hour period.

The results are shown on the graph above.

It is true to say that during this 12 hour period, the value of the Australian dollar

- A. was constant
- B. didn't drop below 50 U.S. cents
- C. stayed on 50 U.S. cents for most of the time
- D. was above 50 U.S. cents for about 4 hours
- E. was less than 50 U.S. cents for about 6 hours

The following information relates to Questions 6 and 7.

The feasible region for a linear programming problem is represented by the shaded region (with boundaries included) shown below.

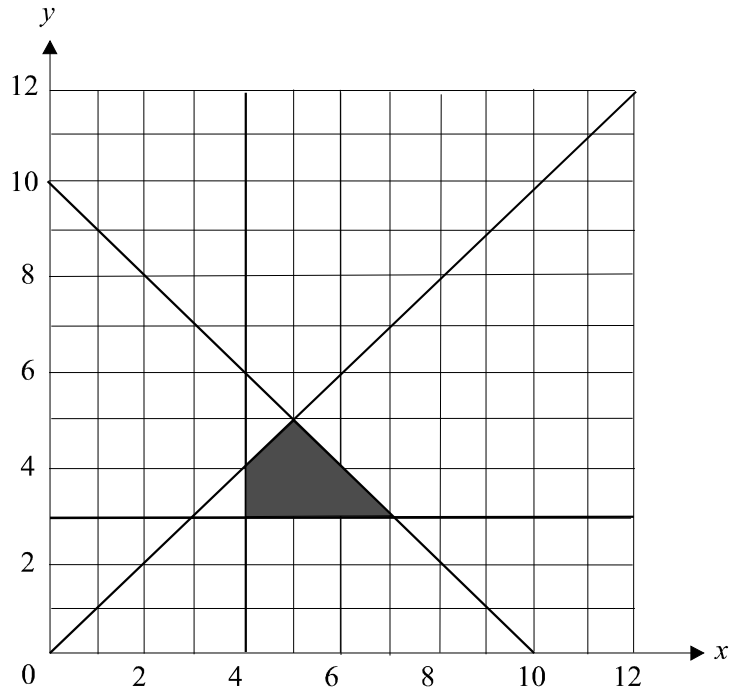

Question 6

The constraints used to define this region are

- A. $x \geq 3$, $y \geq 4$, $y \leq x$, $y \leq x + 10$
- B. $x \geq 3$, $y \geq 4$, $y \geq x$, $x + y \leq 10$
- C. $x \geq 4$, $y \geq 3$, $y \leq x$, $x + y \leq 10$
- D. $x \geq 4$, $y \geq 3$, $y \geq x$, $y \leq x + 10$
- E. $x \geq 11$, $y \leq 11$, $y \geq x$, $2x + 3y \leq 10$

Question 7

For any point (x, y) in the feasible region, the smallest value of $2x - 3y$ is

- A. -30
- B. -6
- C. -5
- D. -4
- E. -1

Question 8

The graph of y against x^3 is shown below.

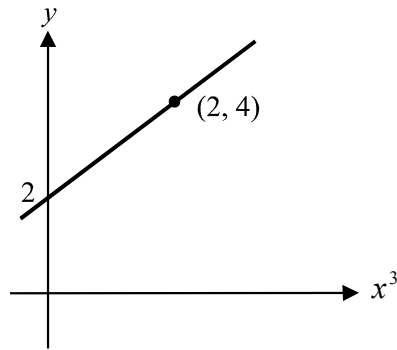

The rule connecting x and y is

- A. $y = 2x^3$
- B. $y = 2x^3 + 2$
- C. $y = 2x^3 + 4$
- D. $y = x^3 + 2$
- E. $y = x^3 + 4$

Question 9

The cost, C , in dollars of hiring a marquee is given by $C = ax + b$ where

- x is the number of days of hiring
- a is the cost per day for hiring
- b is a fixed cost

Jack hired a marquee for 3 days and the cost was \$430.

Sam hired a marquee for 5 days and the cost was \$670.

The cost per day of hiring a marquee is

- A. \$70
- B. \$120
- C. \$135
- D. \$137.50
- E. \$140

Module 4 : Business related mathematics

If you choose this module, **all** questions must be answered.

Question 1

Lee invests \$8000 for 3 years in an account which attracts simple interest. He earns a total of \$840 in interest. The annual rate of interest for this account was

- A. 1.05%
- B. 2.8%
- C. 3.17%
- D. 3.5%
- E. 8.4%

Question 2

An art collection valued at \$75 000 is predicted to increase in value each year by 4%. The predicted value of the collection in 10 years would be

- A. \$106 748.39
- B. \$111 018.32
- C. \$300 00.00
- D. \$1 297 461.38
- E. \$2 169 409.91

Question 3

Miranda's company car was bought for \$45 000 and depreciates at 34 cents per kilometre traveled. Company policy states that company cars must be traded in when they reach a book value of \$20 000.

The number of kilometers that Miranda's company car can be driven before it is traded, is closest to

- A. 58 824
- B. 73 529
- C. 85 000
- D. 112 500
- E. 132 353

Question 4

Gunter invested \$5000 at 4.8% per annum compounding monthly. After 4 years, the value of Gunter's investment will be

- A. \$5 080.48
- B. \$6 031.36
- C. \$6 056.03
- D. \$8 776.18
- E. \$47 458.23

Question 5

The last 5 transactions in Ben's savings account are shown below.

date	transaction detail	debit	credit	balance
05 Apr 01	balance brought forward			4582.79
09 May 01	deposit		300.00	4882.79
28 May 01	debit	180.00		4702.79
01 Jun 01	deposit		320.00	5022.79
25 Jun 01	deposit		260.00	5282.79

Interest on this account is calculated at 0.2% per month based on the **minimum** monthly balance.

The interest paid on Ben's account for the month of May was

- A. \$7.64
- B. \$8.14
- C. \$9.17
- D. \$9.41
- E. \$9.77

Question 6

Enrico enters a hire purchase arrangement in order to buy a first home furniture package which costs \$2800. He pays a deposit of \$400 and \$50 per month for 5 years.

The flat rate of interest being paid by Enrico under this agreement is closest to

- A. 4%
- B. 8.33%
- C. 14.62%
- D. 17.65%
- E. 25%

Question 7

In the first year of harvesting, a walnut plantation produced 15 tonnes of walnuts. Production increased by the same fixed percentage of each previous years harvest thereafter.

Which one of the following graphs could best represent the annual walnut production at this plantation?

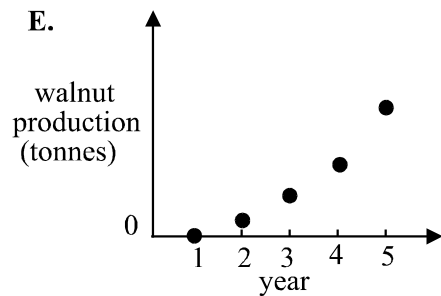
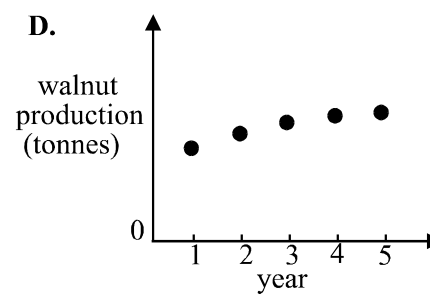
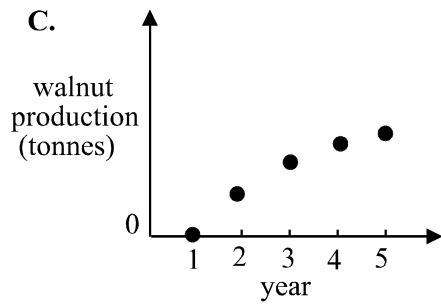
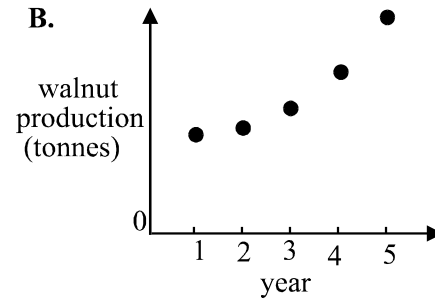
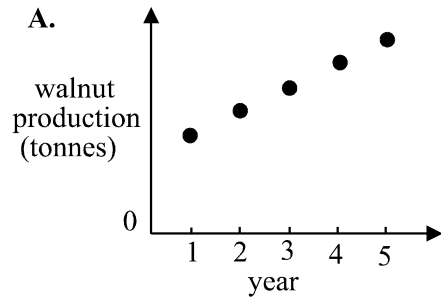

Question 8

Greg takes out a reducing balance loan of \$30 000 at an annual interest rate of 12% per annum. Greg will repay the loan in 5 years and make quarterly repayments of Q dollars.

Which one of the following annuity equations would enable Greg to correctly find the value of Q ?

- A. $0 = 30\,000(1.03)^{20} - \frac{Q(1.03^{20} - 1)}{0.03}$
- B. $0 = 30\,000(1.12)^5 - \frac{Q(1.12^5 - 1)}{0.03}$
- C. $0 = 30\,000(1.04)^5 - \frac{Q(1.04^5 - 1)}{0.03}$
- D. $30\,000 = 30\,000(1.12)^5 - \frac{Q(1.12^5 - 1)}{0.03}$
- E. $30\,000 = 30\,000(1.03)^{20} - \frac{Q(1.03^{20} - 1)}{0.03}$

Question 9

The statement shown below gives the details of a reducing balance loan of \$8000 taken out by Hui on 1st July. Hui makes a repayment of \$200 on the last day of each month and the interest on the balance owing is made on the 1st day of each month.

date	interest	repayment	balance owing
01 Jul 01			8000.00
31 Jul 01		200.00	7800.00
01 Aug 01	39.00		7839.00
31 Aug 01		200.00	7639.00
01 Sep 01	38.20		7677.20

The annual rate of interest being charged to Hui is

- A. 0.4875%
- B. 0.5%
- C. 3.9%
- D. 5.85%
- E. 6%

Module 5 : Networks and decision mathematicsIf you choose this module, **all** questions must be answered.**Question 1**

How many edges will a complete graph with 4 vertices have?

- A. 2
- B. 4
- C. 6
- D. 8
- E. 12

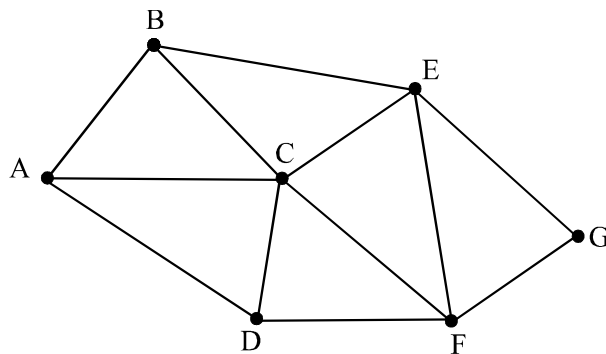
Question 2

For the graph shown above, ABECDFG could be described as

- A. an Euler path
- B. an Euler circuit
- C. a Hamiltonian path
- D. a Hamiltonian circuit
- E. a degenerate circuit

Question 3

A connected graph with 8 vertices and 13 edges divides the plane into how many regions?

- A. 5
- B. 7
- C. 15
- D. 21
- E. 23

Question 4

The bipartite graph below shows child preferences for four flavours of cordial.

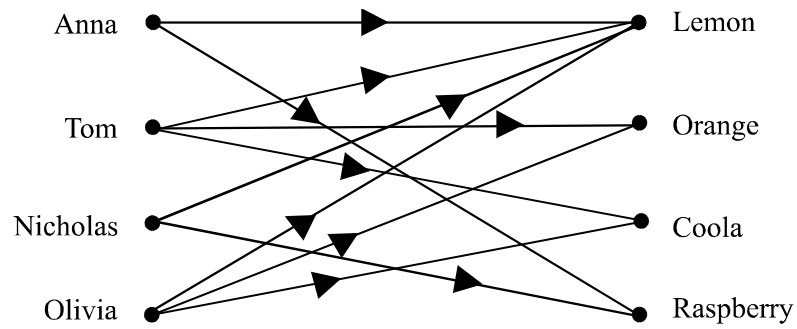

Which one of the following statements is **not** true according to the graph?

- A. Tom and Olivia enjoy the same flavours
- B. Lemon is the most preferred cordial
- C. None of the children preferred all 4 types of cordial
- D. Nicholas prefers the least number of types of all the children
- E. Orange, coola and raspberry are equally preferred by this group of children

Question 5

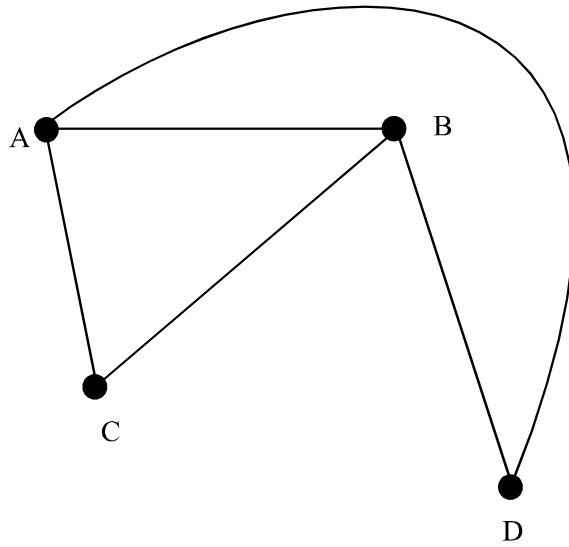

Which one of the following is not a subgraph of the graph shown above?

A.

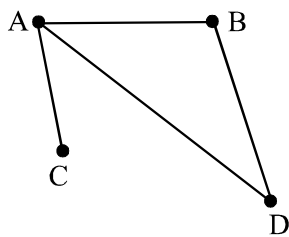

B.

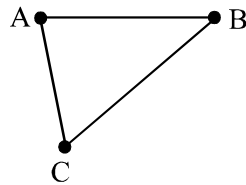

C.

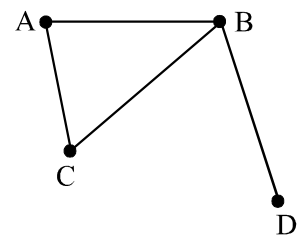

D.

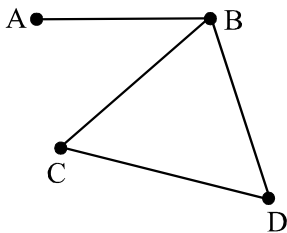

E.

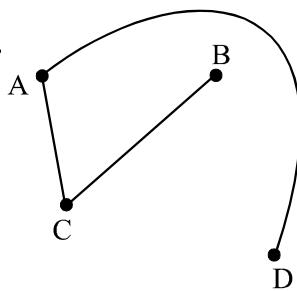

Question 6

A minimum spanning tree for the weighted graph shown below would have weights on its edges that added to give

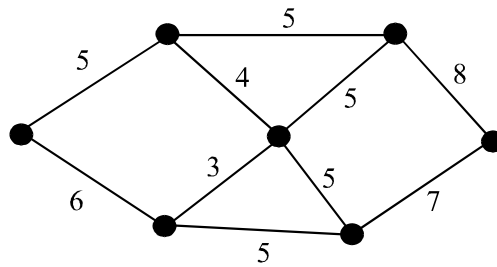

- A. 24
- B. 29
- C. 36
- D. 39
- E. 53

Question 7

The adjacency matrix

$$\begin{matrix} & \begin{matrix} A & B & C \end{matrix} \\ \begin{matrix} A \\ B \\ C \end{matrix} & \begin{bmatrix} 0 & 2 & 1 \\ 0 & 0 & 1 \\ 0 & 1 & 0 \end{bmatrix} \end{matrix}$$

can be used to represent which one of the following graphs?

A.

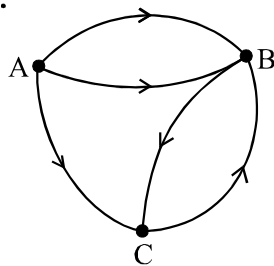

B.

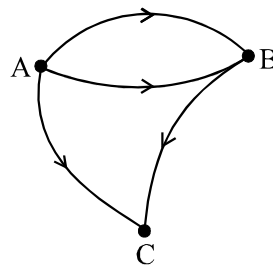

C.

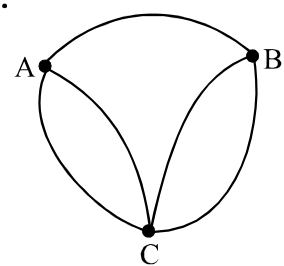

D.

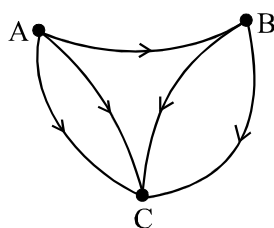

E.

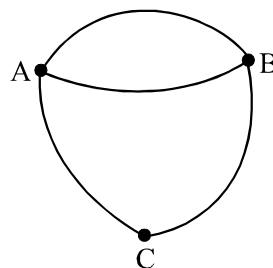

Question 8

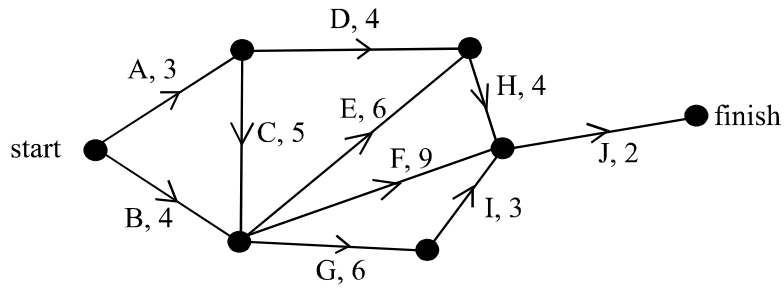

For the network shown above, the time taken, in weeks, for each of the respective tasks A, B, C, ..., are indicated on each of the arcs.

The earliest start time, in weeks, after the project has started for activity J is

- A. 11
- B. 13
- C. 14
- D. 17
- E. 18

Question 9

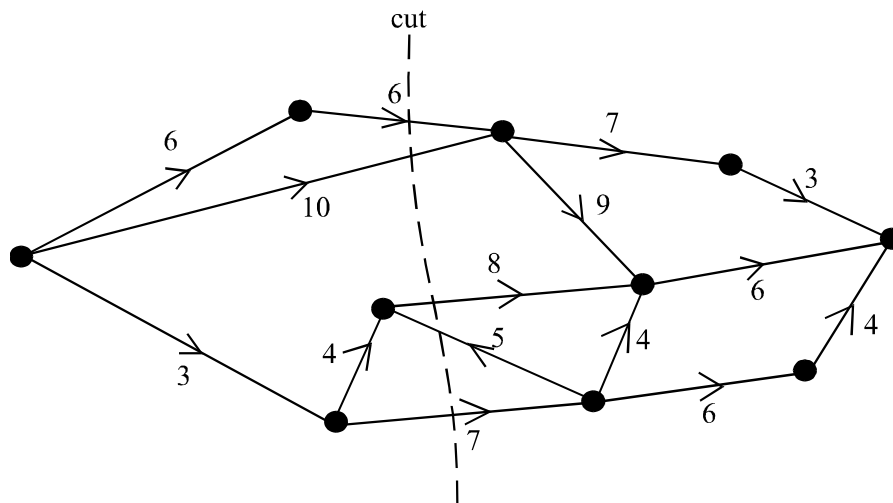

For the graph shown above, the capacity of the cut indicated is

- A. 0
- B. 13
- C. 21
- D. 31
- E. 36

FURTHER MATHEMATICS

TRIAL EXAMINATION 1

2001

MULTIPLE- CHOICE ANSWER SHEET

STUDENT NAME:.....

INSTRUCTIONS

Fill in the letter that corresponds to your choice. Example: A B C D E

The answer selected is B. Only one answer should be selected.

Section A - Core

Section B - Modules

1. A B C D E
2. A B C D E
3. A B C D E
4. A B C D E
5. A B C D E
6. A B C D E
7. A B C D E
8. A B C D E
9. A B C D E
10. A B C D E
11. A B C D E
12. A B C D E
13. A B C D E

Module Number ____

1. A B C D E
2. A B C D E
3. A B C D E
4. A B C D E
5. A B C D E
6. A B C D E
7. A B C D E
8. A B C D E
9. A B C D E

5. A B C D E
6. A B C D E
7. A B C D E
8. A B C D E
9. A B C D E

Module Number ____

1. A B C D E
2. A B C D E
3. A B C D E
4. A B C D E

1. A B C D E
2. A B C D E
3. A B C D E
4. A B C D E
5. A B C D E
6. A B C D E
7. A B C D E
8. A B C D E
9. A B C D E