



Units 3 and 4 Further Maths: Exam 2

Practice Exam Question and Answer Booklet

Duration: 15 minutes reading time, 1 hour 30 minutes writing time

Structure of book:

Section	Number of questions	Number of questions to be answered	Number of modules	Number of modules to be answered	Number of marks
Core	4	4			15
Modules			6	3	45
				Total	60

- Students are permitted to bring into the examination room: pens, pencils, highlighters, erasers, sharpeners, rulers, one bound reference, one approved graphics calculator or approved CAS calculator or CAS software and if desired, one scientific calculator. Calculator memory DOES NOT need to be cleared.
- Students are not permitted to bring into the examination room: blank sheets of paper and/or white out liquid/tape.

Materials supplied:

- This question and answer booklet of 32 pages, with a sheet of miscellaneous formulas.

Instructions:

- Detach the formula sheet from this book during reading time.
- Unless otherwise indicated, the diagrams in this book are **not** drawn to scale.
- Write all your answers in the spaces provided in this booklet.

Instructions

This examination consists of a core and six modules. Students should answer **all** questions in the core then select **three** modules and answer **all** questions within the modules selected.

You need not give numerical answers as decimals unless instructed to do so. Alternative forms may involve, for example, π , surds or fractions.

Diagrams are not to scale unless specified otherwise.

Core: Data analysis

Question 1

The parallel box plots below show the distributions of scores received by students in a recent maths exam sat by three different year levels.

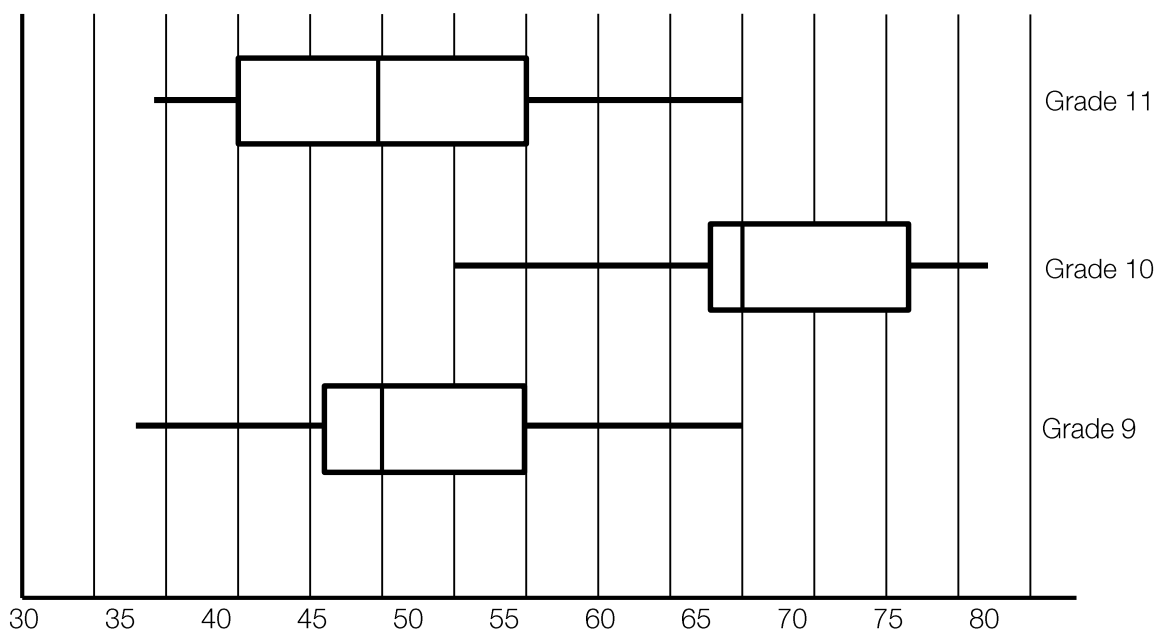

- a. What was the median grade received by year 9 students?

1 mark

- b. Determine the interquartile range of the scores received by the Grade 11 students.

1 mark

- c. It has been suggested that year level and maths scores are positively related. Do the above three parallel box plots support this statement? Justify your answer using an appropriate statistic.

1 mark

- d. A grade 9 student's score of 82 was accidentally not included in the above boxplot. If her grade was added, would this student's score show as an outlier on the bow plot? Give reasons for your answer, showing appropriate calculations.

2 marks

Question 2

Table 1 shows the percentage of boys enrolled in the 12 different grade nine classes offered by a school.

Subject	Percentage of boys in the class
Maths	56
English	48
Chemistry	43
P.E.	51
Biology	49
Accounting	39
Religion	53
Philosophy	22
German	44
Literature	60
History	58
French	49

Table 1

- a. What percentage of the subjects have more than 50% boys enrolled? Give your answer correct to one decimal place.

1 mark

- b. Determine the median and mean for this data. Give your answer correct to one decimal place.

Median:

Mean:

1 + 1 = 2 marks

- c. If each subject had the same amount of students in it then this data shows that there are more girls in grade nine than boys.
Explain why.

1 mark

Question 3

The number of hours a week spent studying and the average grades of a group of year 10 students was recorded and is displayed in the scatter plot below.

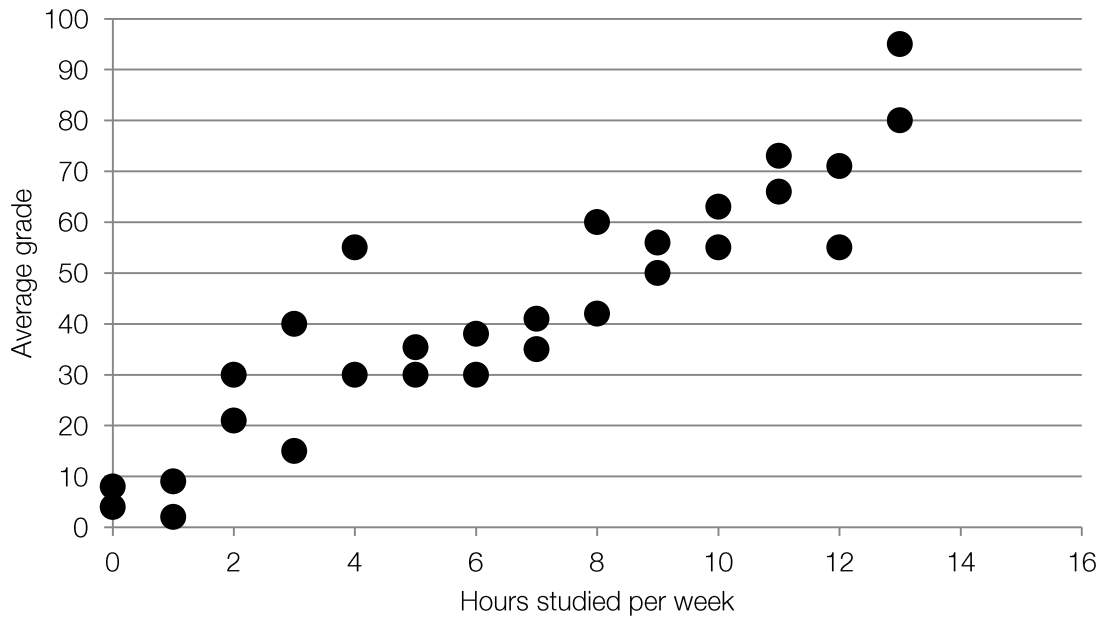

An equation for the least squares regression line is:

$$\text{Grade average} = 4.7 + 5.5 \times \text{number of study hours}$$

a. Draw this line on the scatter plot.

1 mark

b. Complete the following sentence by writing the missing amount in the box below:

On average, a student's grade average increases by for each extra study hour per week.

1 mark

c. The actual grade average of a student who studied for 15 hours was 94. Determine the residual value when the trend line is used to predict the grade average of this student. Write your answer correct to two decimal places.

1 mark

d. What is the independent variable?

1 mark

Question 4

The histogram below shows the distribution of students in different year levels who catch the bus to school:

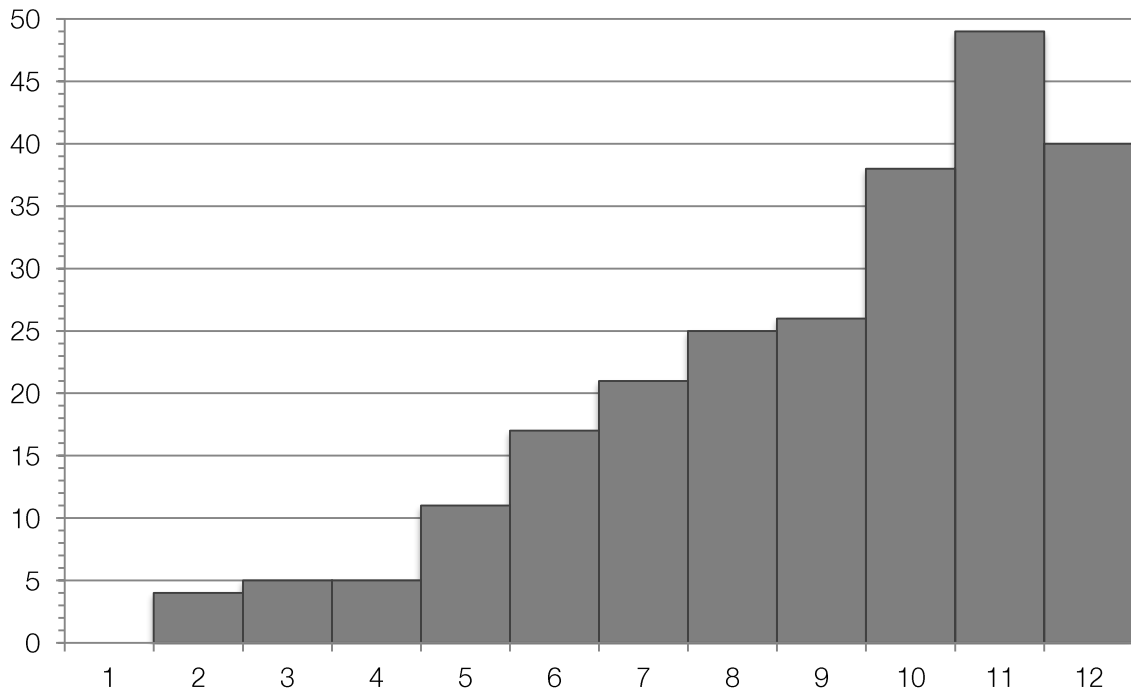

- a. Describe the shape of the histogram.

1 mark

- b. Determine the percentage of grade levels that have 25 or more students catching the bus.

1 mark

Total 15 marks

Modules

Module 1: Number patterns

Question 1

The original population of Hope town is 1398. Every year 45 people leave Hope town to go to the City.

- a. Write the equation that represents how many people are in the town, P_n , at the end of every the n th year.

1 mark

- b. How many people will be in the town after 6 years?

1 mark

- c. How many years will it be until there are only:
i. 723 people in the town?

ii. No more people in the town?

1 + 1 = 2 marks

- d. How many more people are in the town after two years than there will be after fifteen?

1 mark

Question 2

The following difference equation represents how many people, P_n , are in the City after n years. It takes into account births, deaths and the people who come from Hope Town.

$$P_n = 1.12P_{n-1} + 45, P_2 = 8990$$

- a. How many people, P_n , were in the town at time $n = 0$? Write your answer correct to the nearest whole number.

1 mark

- b. How many more people will there be in the third year than in the fourth year? Write your answer correct to the nearest whole number.

1 mark

- c. According to this difference equation, the number of people in the City increases by a certain percentage each year before taking into account the 45 people that come from Hope Town. What is this percentage increase? Write your answer correct to one decimal place.

1 mark

- d. How many years will it be until there are over 15000 people in the City?

1 mark

- e. Show that the sequence generated by this difference equation is not arithmetic.

1 mark

Question 3

The number of births in the City in year n is given by the n^{th} term in the following arithmetic sequence.

120, 138, 156, ...

- a. What is the common difference in this sequence?

1 mark

- b. Find how many babies will be born in the city in the 5th year.

1 mark

- c. The number of babies born in the city, B_n , in the n^{th} year can be represented by the following differential equation:

$$B_n = SB_{n-1} + K$$

Find the values of S and K , and write them in the boxes below.

$S =$

$K =$

1 + 1 = 2 marks

- d. Use this differential equation to predict the year in which there will be 264 births.

1 mark

Total 15 marks

*Module 2: Geometry and trigonometry***Question 1**

An old tree stands high in a park. A caterpillar is crawling towards the tree and at the moment shown in the diagram below the caterpillar is 13.4 meters away from the tree. At this moment the angle of elevation from the caterpillar to the top of the tree is 28° .

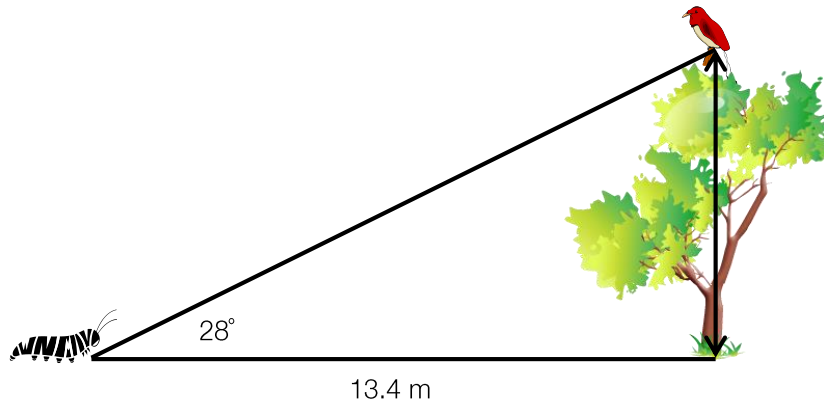

- a. What is the height of the tree correct to 1 decimal place?

1 mark

- b. The caterpillar now crawls a further 3 meters towards the tree. A bird sitting on the top of the tree spots the caterpillar. What is the angle of depression to one decimal place from the bird to the caterpillar?

1 mark

- c. A painter comes to the park and wants to draw the tree. He wishes to draw the tree to scale. If on his canvas draws the height of the tree to be 30cm what is scale factor of his drawing?

1 mark

A bird's eye view of the park is shown below. A represents the location of the tree, B represents the location of the caterpillar and C represents the location of where the painter is sitting.

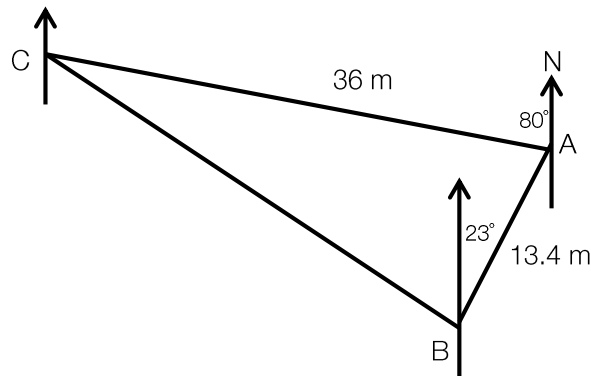

- d. What is the distance to the nearest tenth of a meter from the painter to the caterpillar?

1 mark

- e. What is the bearing of painter from the caterpillar (that is the bearing of C from B)? Give your answer to the nearest degree.

2 marks

Question 2

The owners of the park want to build a pavilion. The design of the pavilion is shown below. Note the diagram is not to scale.

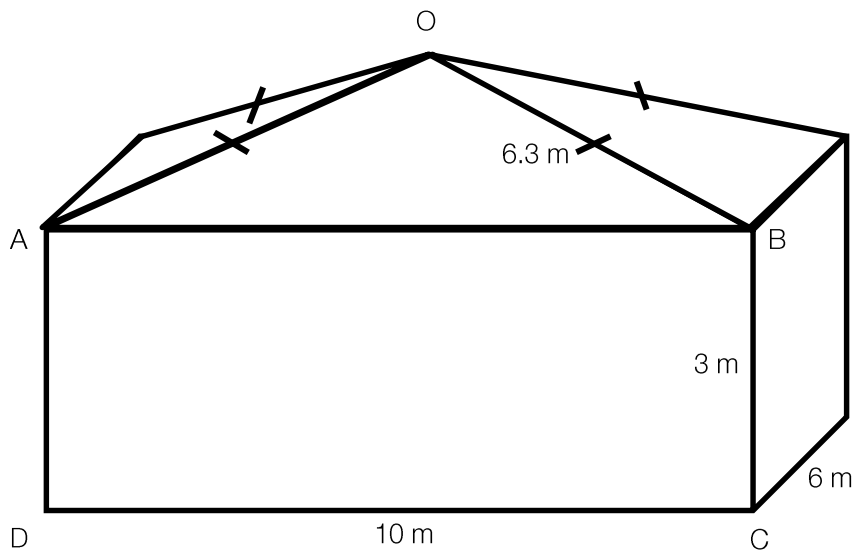

- a. How tall is the pavilion from its base to the top of roof (O)? Give your solution to the nearest tenth of a meter.

1 mark

- b. Find the volume of the pavillion correct to 2 decimal places.

1 mark

- c. If the owners of the park decided the pavilion didn't need to be so large and reduced the dimensions by half i.e. the base of the pavilion is now 5 m by 3 m and the slope of the roof is 3.15 m, what percentage reduction of volume has been achieved?

2 marks

Question 3

Helen wishes store all her knitting needles in a container. The container she decides to use is composed of a cylinder with a hemisphere on the top. The container along with its dimensions is shown in the diagram below.

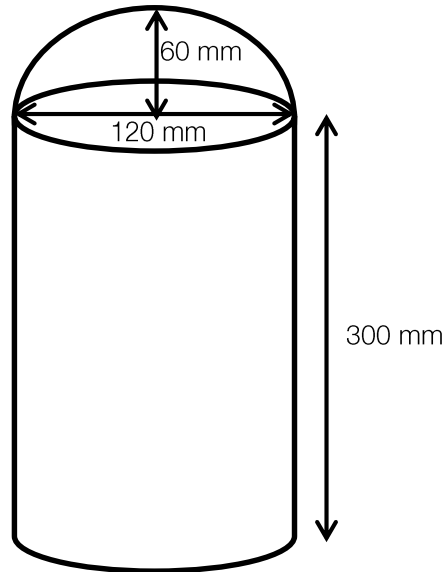

- a. What is the volume of the capsule in cm^3 ? Give your answer to one decimal place.

1 mark

- b. What is the total surface area of time capsule cm^2 ? Give your answer to one decimal place.

1 mark

Helen finds a rectangular box with dimensions 30 cm by 35 cm by 20 cm and decides to use this as her knitting needle holder.

- c. What is the longest knitting needle to the nearest cm that she could fit in this new container?

2 marks

Total 15 marks

Module 3: Graphs and relations

Question 1

Foodies, the local Supermarket, has just established a home delivery service. The cost of having groceries home delivered depends on the weight of the groceries, as shown on the graph below.

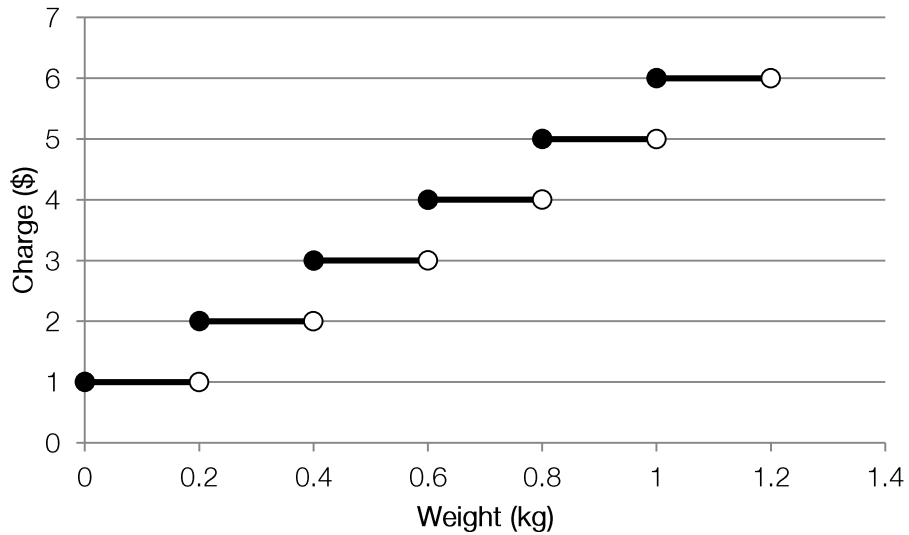

- a. How much would it cost to have 0.4 kg of groceries home delivered?

1 mark

- b. How much would it cost to have 1.1 kg of groceries home delivered?

1 mark

- c. Assuming the graph continues along the same pattern, how much would it cost to have 6 kg of groceries delivered?

2 marks

- d. Sarah does not want to use the home delivery services. She decides to drive to Foodies to buy some chips and chocolate. She only has \$10 in her purse. She takes 3 chocolate bar and 2 chip packets to the counter, but together it costs \$10.20. So instead, she buys 2 chocolate bar and 3 chip packets for \$9.30.

Let b = the number of chocolate bars bought.

Let p = the number of chip packets bought.

- i. Write a system of simultaneous equations that represents this information.

2 marks

- ii. Hence, find the cost of buying only one chocolate bar and one chip packet together.

3 marks

Question 2

A farmer desires to create a guinea pig business and starts breeding them to be sold. The table below shows the increase in guinea pigs over a 12 month period.

Time (in months)	2	4	6	8	10	12
Number of guinea pigs	1	4	9	16	25	32

The number of guinea pigs bred (G) and the time elapsed in months (t) can be represented by through the equation:

$$G = kt^n$$

- a. If $n = 2$, find the value of k .

2 marks

- b. If the growth continues at this rate, how many guinea pigs will have been bred by the end of 3 years?

2 marks

- c. After three years of breeding, the farmer decides to set up the business and start selling his guinea pigs. The total cost of setting up the business amounts to \$16 281. If the farmer plans to sell guinea pigs (after three years) for the same price each until they are all sold. How much must each guinea pig cost in order for the farmer to break even?

2 marks

Total 15 marks

*Module 4: Business-related mathematics***Question 1**

A coffee machine retails at \$399 at Big Jim's Bargain Warehouse. Jacqui really wants to buy the coffee machine but doesn't have enough money to pay for it outright, so instead she puts it on her credit card.

- a. If Jacqui's credit card has an interest rate of 15% per annum, compounded monthly, how much interest will Jacqui accumulate over 3 months if she makes no repayments? Give your answer to the nearest cent.

1 mark

- b. Jacqui can afford repayments of \$140 per month. Fill out the following table (round your answers to the nearest cent) to determine how many months it will take Jacqui to pay for the coffee machine. Assume \$140 is paid off the principal amount at the end of each month after the interest has been added.

End of month	Interest (\$)	Repayment (\$)	Balance of loan (\$)

2 marks

Question 2

Big Jim's Bargain Warehouse offers its customers the option of entering a hire-purchase agreement in order to buy the coffee maker. Another customer Joe decides to use this option to buy the \$399 coffee machine.

- a. If Joe is to pay a \$50 deposit, and then \$45 per month for 8 months, how much interest will Joe pay?

1 mark

- b. What is the flat interest rate per annum that this represents? Round your answer to two decimal points.

1 mark

- c. What is the effective interest rate that this represents? Round your answer to two decimal points.

1 mark

Question 3

Coffee enthusiast Kelly desires to purchase a top of the range coffee machine, the CoffeePro 3000. The trouble is it retails at \$3000 and Kelly only has \$1000 saved up so far. In order to save up the extra \$2000, Kelly thinks about investing her money.

- a. If she deposits her \$1000 in an account paying 8.3% per annum, compounding quarterly, what will be the value of Kelly's investment after a year?

1 mark

- b. If Kelly were to keep her money in this account how many years would it take for Kelly to have gained enough money in interest to pay for the coffee machine? Round your answer to the nearest year.

2 marks

- c. Suppose the average annual inflation rate is 2.1% what will be the price of the coffee machine when Kelly finally has enough money to purchase it?

2 marks

Question 4

Kelly obviously doesn't want to wait that long for the coffee machine so instead she takes out a reducing balance loan for \$2000. Interest is calculated at 8.2% per annum.

- a. If Kelly wants to pay off the loan in 12 months with equal monthly repayments what will be the value of these repayments?

1 mark

- b. If instead Kelly makes equal monthly repayments of \$30 how many months will it take to pay off the loan? How much does she have to pay in her last repayment?

2 marks

- c. Under the \$30 per month repayment scheme how much interest is Kelly paying for this loan?

1 mark

Total 15 marks

Module 5: Networks and decision mathematics

Question 1

Janet and Kelly are planning to go on a bike ride. There are many bike paths in their area. The network below shows the distances in kilometres of the paths.

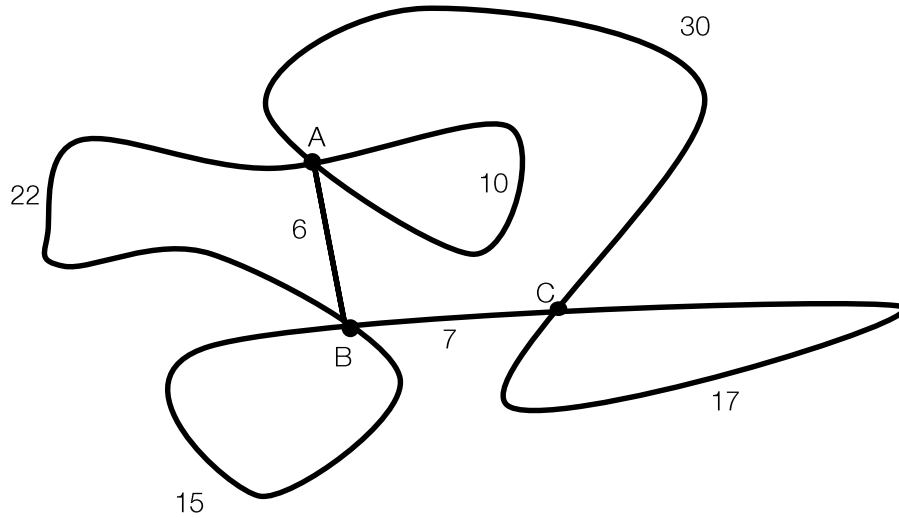

a. How many faces does this network have?

1 mark

b. What is the sum of the degrees of the vertices?

1 mark

c. Construct an adjacency matrix for this bike path network.

1 mark

Adjacency matrices are used for both undirected graphs (like the bike path network) and directed graphs. Reachability matrices are particularly useful for directed graphs. An example of a one-step reachability matrix between elements W, X, Y and Z is shown below.

	W	X	Y	Z
W	0	1	0	0
X	0	0	1	0
Y	0	0	0	0
Z	1	0	1	0

- d. Explain the significance of the zeros in the third row

1 mark

Question 2

Below is a network showing the routes between tourist sightseeing points on an island. The various points of interest are labelled A through to E.

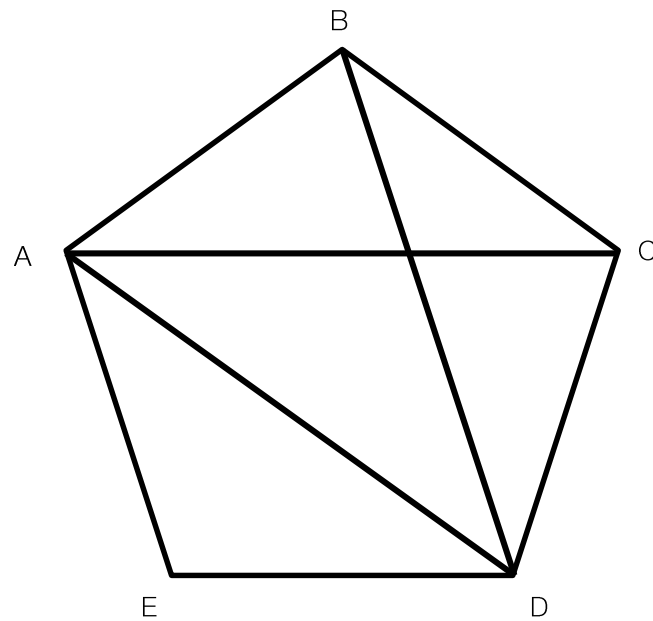

a. Is the network above a planar graph? Explain.

1 mark

b. Give an example of an Euler path for this network.

1 mark

c. Give an example of a Hamiltonian circuit for this network.

1 mark

The park rangers on the island want to preserve the island and so want to limit the number of tourists that are on the paths at any one time. All of the paths are very narrow and so they are all one way. The direction of the paths and their capacities are shown below.

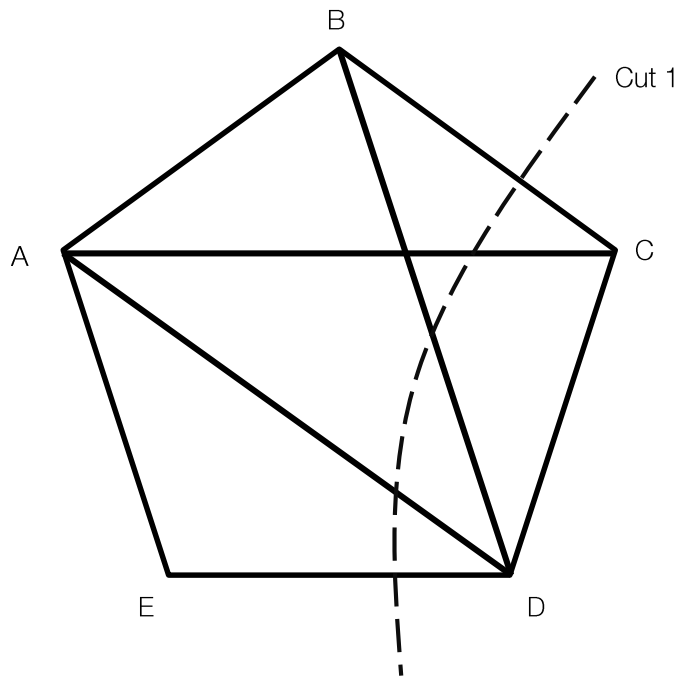

Path	Number of tourists allowed
A to B	4
B to C	6
C to A	5
B to D	5
D to C	7
A to D	4
E to A	8
D to E	5

A cut has been made on the network above.

d. What is the capacity of this cut?

1 mark

e. What is the maximum number of tourists that can travel from A to C?

2 marks

Question 3

An owner of a chain of furniture stores has four factories that construct the products and four retail stores that sell the products to the consumers. Due to the distance between the factories and stores it costs different amounts to transport the goods from a particular factory to a particular store. The cost (in dollars) of providing the furniture is summarised in the following table. The owner wants to minimise the cost of transporting the furniture

Supplying to	Factory based at			
	Location 1	Location 2	Location 3	Location 4
Shop A	110	95	140	80
Shop B	105	82	145	80
Shop C	127	78	140	75
Shop D	115	90	135	85

- a. The Hungarian algorithm is used to determine which factory should supply which shop. Complete the table below which shows the values of the table after step 1 of the algorithm.

Supplying to	Factory based at			
	Location 1	Location 2	Location 3	Location 4
Shop A	30	15	60	0
Shop B	25	2	65	0
Shop C				
Shop D	30	5	50	0

1 mark

- b. What will the table look like after step 2?

Supplying to	Factory based at			
	Location 1	Location 2	Location 3	Location 4
Shop A				
Shop B				
Shop C				
Shop D				

1 mark

- c. Continue the algorithm until you are able to allocate a factory to a shop and complete the table. Explain your choice.

Factory at	Assign to shop
Location 1	
Location 2	
Location 3	
Location 4	

Explanation:

Use the following blank tables for working out (you may or may not need all of them):

Supplying to	Factory based at			
	Location 1	Location 2	Location 3	Location 4
Shop A				
Shop B				
Shop C				
Shop D				

Supplying to	Factory based at			
	Location 1	Location 2	Location 3	Location 4
Shop A				
Shop B				
Shop C				
Shop D				

Supplying to	Factory based at			
	Location 1	Location 2	Location 3	Location 4
Shop A				
Shop B				
Shop C				
Shop D				

2 marks

d. Hence what is the minimum cost of transport to supply all the stores with furniture?

1 mark

Total 15 marks

*Module 6: Matrices***Question 1**

For the matrix $T = \begin{bmatrix} 3 & 4 \\ 5 & 6 \end{bmatrix}$,

- a. State the order of the matrix.

1 mark

- b. Find the determinant of the matrix.

1 marks

- c. If $B = [1 \ 2]$, what is the value of BT ?

1 mark

Question 2

Consider the following system of linear equations:

$$4x + 3y = 12$$

$$-2x - y = 18$$

- a. Write the matrix equation that represents this information.

2 marks

- b. If $A = \begin{bmatrix} 4 & 3 \\ -2 & -1 \end{bmatrix}$ then find the value of A^{-1}

2 marks

- c. Hence, solve the system of simultaneous equations.

2 marks

Question 3

The owner of a local tennis club examines the daily use of the tennis facilities by its club members. He discovers that 60% of members who play tennis on one day will not play tennis the next day, whereas 40% will. Also, 75% of members who do not play tennis on one day will play tennis the next day, but 25% will not.

- a. Complete the transition matrix that represents this information.

$$\begin{bmatrix} .4 & \\ .6 & \end{bmatrix}$$

1 mark

The tennis club has 200 members. On Monday, 120 members play tennis and 80 do not.

- b. State the initial state matrix, S_0 .

1 mark

- c. How many people will not play tennis on Tuesday?

2 marks

- d. In the long term, approximately how many people will play tennis and how many will not?

2 marks

Total 15 marks

Formula Sheet

Core: Data analysis

Standardised score: $z = \frac{x - \bar{x}}{s_x}$

Least squares line: $y = a + bx$ where $b = r \frac{s_y}{s_x}$ and $a = \bar{y} - b\bar{x}$

Residual value: residual value = actual value – predicted value

Seasonal index: seasonal index = $\frac{\text{actual figure}}{\text{deseasonalised figure}}$

Module 1: Number patterns

Arithmetic series: $a + (a + d) + \dots + (a + (n - 1)d) = \frac{n}{2}[2a + (n - 1)d] = \frac{n}{2}(a + l)$

Geometric series: $a + ar + ar^2 + \dots + ar^{n-1} = \frac{a(1 - r^n)}{1 - r}, r \neq 1$

Infinite geometric series: $a + ar + ar^2 + ar^3 + \dots = \frac{a}{1 - r}, |r| < 1$

Module 2: Geometry and trigonometry

Area of a triangle: $\frac{1}{2}bc \sin A$

Heron's formula: $A = \sqrt{s(s - a)(s - b)(s - c)}$, where $s = \frac{1}{2}(a + b + c)$

Circumference of a circle: $2\pi r$

Area of a circle: πr^2

Volume of a sphere: $\frac{4}{3}\pi r^3$

Surface area of a sphere: $4\pi r^2$

Volume of a cone: $\frac{1}{3}\pi r^2 h$

Volume of a cylinder: $\pi r^2 h$

Volume of a prism: area of base \times height

Volume of a pyramid: $\frac{1}{3}$ area of base \times height

Pythagoras' theorem: $c^2 = a^2 + b^2$

Sine rule: $\frac{a}{\sin A} = \frac{b}{\sin B} = \frac{c}{\sin C}$

Cosine rule: $c^2 = a^2 + b^2 - 2ab \cos C$

Module 3: Graphs and relations

Straight line graphs

Gradient (slope): $m = \frac{y_2 - y_1}{x_2 - x_1}$

Equation: $y = mx + c$

Module 4: Business-related mathematics

Simple interest: $I = \frac{PrT}{100}$

Compound interest: $A = PR^n$, where $R = 1 + \frac{r}{100}$

Hire purchase: effective rate of interest $\approx \frac{2n}{n+1} \times \text{flat rate}$

Module 5: Networks and decision mathematics

Euler's formula: $v + f = e + 2$

Module 6: Matrices

Determinant of a 2 x 2 matrix: $A = \begin{bmatrix} a & b \\ c & d \end{bmatrix}$, $\det A = \begin{vmatrix} a & b \\ c & d \end{vmatrix} = ad - bc$

Inverse of a 2 x 2 matrix: $A^{-1} = \frac{1}{\det A} \begin{bmatrix} d & -b \\ -c & a \end{bmatrix}$, where $\det A \neq 0$

End of Booklet

Looking for solutions? Visit www.engageeducation.org.au/practice-exams

To enrol in one of our Further Maths lectures head to: <http://engageeducation.org.au/lectures/>