



INSIGHT
YEAR 11 Trial Exam Paper

2012
PHYSICS
Written examination 1

Worked solutions

This book presents:

- worked solutions, giving you a series of points to show you how to work through the questions
- mark allocation details
- tips

This trial examination produced by Insight Publications is NOT an official VCAA paper for the 2012 Physics written examination 1.

This examination paper is licensed to be printed, photocopied or placed on the school intranet and used only within the confines of the purchasing school for examining their students. No trial examination or part thereof may be issued or passed on to any other party including other schools, practising or non-practising teachers, tutors, parents, websites or publishing agencies without the written consent of Insight Publications.

This page is blank

SECTION A – Core**Area of study 1 – Nuclear physics and radioactivity****Question 1**

An **ionised** uranium isotope can be written as ${}_{92}^{235}\text{U}^{++}$.

Find the

- a. atomic number. 1 mark
- b. mass number. 1 mark
- c. number of neutrons. 1 mark
- d. number of protons. 1 mark
- e. number of electrons. 1 mark

Total 5 marks

Worked solution

- a. Atomic number = 92
b. Mass number = 235
c. Number of neutrons = $235 - 92 = 143$
d. Number of protons = 92

Number of electrons = Number of protons – 2 (due to the ++) = 90

Mark allocation

- 1 mark for each correct answer.

The following information applies to questions 2 and 3.

Different types of radiation have different characteristics. The three forms of radiation are alpha, beta and gamma.

Question 2

Place the three forms in order (largest first) of

- | | |
|----------------------|--------|
| a. speed | 1 mark |
| b. penetrating power | 1 mark |
| c. ionising power | 1 mark |
| d. mass | 1 mark |

Total 4 marks

Worked solution

- a. Speed: gamma, beta, alpha.
Gamma is a form of electromagnetic radiation. It travels at the speed of light. Alpha is a helium nucleus and is very slow.
- b. Penetrating power: gamma, beta, alpha.
Gamma has the highest. It has no mass, no charge and a very high frequency and energy.
- c. Ionising power: alpha, beta, gamma.
Alpha is double positive and easily ionises other atoms. Gamma has no charge.
- d. Mass: alpha, beta, gamma.
Alpha is a helium nucleus and is very massive. Gamma has no mass.

Mark allocation

- 1 mark for each correct answer.

Question 3

After Albert Einstein released his theory of relativity, physicists soon realised that mass and energy were interchangeable. Einstein introduced what was to become the world's most famous equation, $E = mc^2$.

In an early experiment, physicists were able to produce 50 eV of energy.

How much is 50 eV in joules?

2 marks

Worked solution

$$\begin{aligned} 50 \text{ eV} &= 50 \times 1.6 \times 10^{-19} \\ &= 8 \times 10^{-18} \text{ joules} \end{aligned}$$

$$8 \times 10^{-18} \text{ J}$$

Mark allocation

- 1 mark for using the correct formula.
- 1 mark for the correct answer.

Question 4

If 5×10^{-22} grams is converted into pure energy, how much would that be?

2 marks

Worked solution

$$\begin{aligned} E &= mc^2 \\ &= 5 \times 10^{-25} \times (3 \times 10^8)^2 \\ &= 4.5 \times 10^{-8} \text{ joules} \end{aligned}$$

$$4.5 \times 10^{-8} \text{ J}$$

Mark allocation

- 1 mark for using the correct formula.
- 1 mark for the correct answer.

Question 5

For the following decay equation, find the values for a and b . **Hence**, find the missing element X.

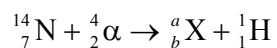

$$a = 17$$

$$b = 8$$

Mystery element = oxygen

3 marks

Worked solution

$$a = 14 + 4 - 1 = 17$$

$$b = 7 + 2 - 1 = 8$$

Atomic number of 8 is oxygen.

Mark allocation

- 1 mark for each correct answer.

Question 6

If Clarice has 2 kilograms of a radioactive material that has a half-life of 6 hours, how much would be left after 2 days? Write your answer in **grams**.

2 marks

Worked solution

$$2 \text{ days} = 48 \text{ hours}$$

$$= 8 \text{ half lives.}$$

$$2 \rightarrow 1 \rightarrow 0.5 \rightarrow 0.25 \rightarrow 0.125 \rightarrow 0.0625 \rightarrow 0.03125 \rightarrow 0.01563 \rightarrow 0.00781 \text{ kg}$$

$$7.812 \text{ grams}$$

7.8 grams

Mark allocation

- 1 mark for calculating 8 half lives.
- 1 mark for the correct answer.

Question 7

Which of the following best describes what happens to an atom that decays?

- A. It decays to nothing.
- B. All original mass is converted to energy.
- C. It blows up.
- D. It decays into another substance, with a small release of energy.

2 marks

D

Worked solution

Radioactive atoms decay into a more stable form by releasing mass and/or energy.

Mark allocation

- 2 marks for the correct answer.

Question 8

A radioactive material is measured to have 6×10^5 decays per second. After 3 half-lives, what will be the activity, in Bq?

2 marks

Worked solution

$$6 \times 10^5 \times \left(\frac{1}{2}\right)^3 = 75000$$

75000 Bq

Mark allocation

- 1 mark for substituting values correctly into the formula.
- 1 mark for the correct answer.

Question 9

Radon-218 decays to polonium-214 as follows.

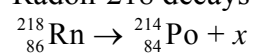

Complete the decay equation by finding x , and thus the type of decay.

2 marks

Worked solution

$$x = {}_2^4\text{He}$$

1 mark

Type of radiation: alpha

1 mark

Mark allocation

- 1 mark for each correct answer.

Question 10

Gavin the radiologist is administering to a sick child. It is an unknown radiation (quality factor = 10) and each treatment gives 1.5×10^{-4} joules.

If the child has a mass of 60 kilograms, calculate each of the following. (Circle the correct unit.)

a. absorbed dose

Gy Sv Bq J eV kg (1 mark)

3 marks

b. dose equivalent

Gy Sv Bq J eV kg (1 mark)

3 marks

Total 6 marks

Worked solutions

a.

$$\begin{aligned} \text{Absorbed dose} &= \frac{1.5 \times 10^{-4}}{60} \\ &= 2.5 \times 10^{-6} \text{ Gy} \end{aligned}$$

Mark allocation

- 1 mark for using the correct formula.
- 1 mark for the correct answer.
- 1 mark for the correct unit (Gy).

b.

$$\begin{aligned} \text{Dose equivalent} &= \text{absorbed dose} \times \text{quality factor} \\ &= 2.5 \times 10^{-6} \times 10 \\ &= 2.5 \times 10^{-5} \text{ Sv} \end{aligned}$$

Mark allocation

- 1 mark for using the correct formula.
- 1 mark for the correct answer.
- 1 mark for the correct unit (Sv).

Question 11

Give **two** examples of places in the human body where it is **very** dangerous to get a dose of radiation.

2 marks

Worked solution

- reproductive organs
- brain
- centres of high nerve density

Mark allocation

- 1 mark for any two correct answers.

Question 12

When an atom undergoes α decay, what happens to its

a. atomic number?

1 mark

b. mass number?

1 mark

Total 2 marks

Worked solutions

- a. Its atomic number decreases by 2 units.
b. Its mass number decreases by 4 units.

Mark allocation

- 1 mark for each correct answer.

END OF AREA OF STUDY 1

Area of study 2 – Electricity

The following information applies to questions 1 to 3.

Figure 1 shows a circuit that has been set up in a lab.



Figure 1

Question 1

What is the direction of the conventional current? Mark it on the diagram above.

1 mark

Worked solution

The current travels from positive to negative, i.e. anti-clockwise.

Mark allocation

- 1 mark for the correct answer.

Question 2

Find the current (in milliamperes) for the circuit shown in **Figure 1**.

2 marks

Worked solution

$$V = IR$$

$$I = \frac{V}{R}$$

$$= \frac{6}{100}$$

$$= 0.06 \text{ A}$$

$$= 60 \text{ mA}$$

60 mA

Mark allocation

- 1 mark for calculating 0.06 A.
- 1 mark for the correct answer.

Question 3

How many joules will the resistor transform in 20 seconds?

2 marks

Worked solution

$$\begin{aligned} E &= VI t \\ &= 6 \times 0.06 \times 20 \\ &= 7.2 \text{ J} \end{aligned}$$

7.2 J

Mark allocation

- 1 mark for correctly substituting values into the correct formula.
- 1 mark for the correct answer.

The following information applies to questions 4 and 5.

Question 4

Is the following graph **ohmic**? Explain.

2 marks

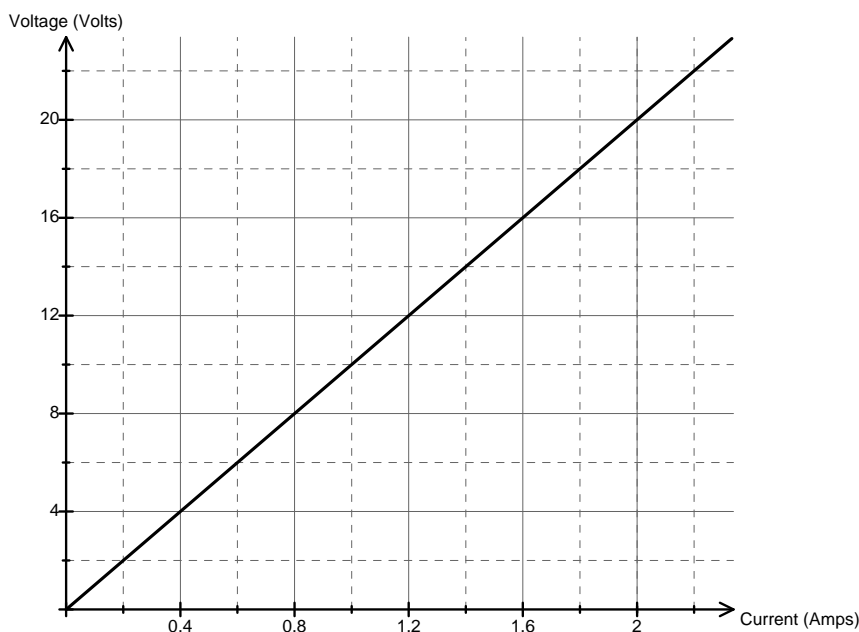

Worked solution

Yes, the graph is ohmic. (1 mark)

The graph is linear/in a straight line and obeys Ohm's law. (1 mark)

Mark allocation

- 1 mark for correct answer.
- 1 mark for correct explanation.

Question 5

Calculate the resistance of the load in this experiment.

1 mark

Worked solution

Find the gradient of the line.

$$\begin{aligned} R &= \frac{V}{I} \\ &= \frac{20}{2} \\ &= 10 \, \Omega \end{aligned}$$

10 Ω

Mark allocation

- 1 mark for the correct answer.

SECTION A – Area of Study 2– continued
TURN OVER

The following information applies to questions 6 to 10.

Sam and Lilly have set up the following circuit in their lab (**Figure 2**).

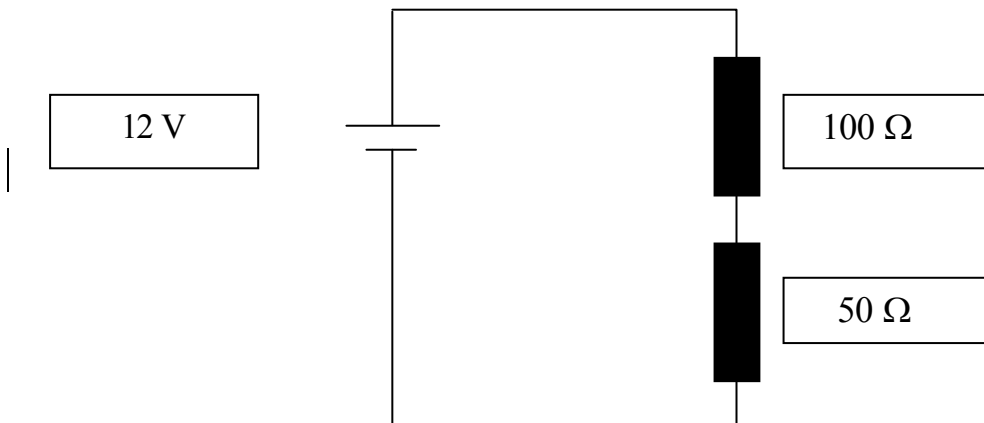

Figure 2

Question 6

Calculate the total resistance of the circuit.

2 marks

Worked solution

Resistors in series, $R_T = R_1 + R_2$

$$\text{Total} = 100 + 50$$

$$R_T = 150 \Omega$$

150 Ω

Mark allocation

- 2 marks for the correct answer.

Question 7

Calculate the current running through Sam and Lilly's circuit.

2 marks

Worked solution

$$\begin{aligned} I &= \frac{V}{R} \\ &= \frac{12}{150} \\ &= 0.08 \text{ A} \end{aligned}$$

0.08 A

Mark allocation

- 1 mark for using the correct formula.
- 1 mark for the correct answer.

Question 8

Calculate the voltage drop over the 100 Ω resistor.

1 mark

Worked solution

$$\begin{aligned} V &= I \times R \\ &= 0.08 \times 100 \\ &= 8 \text{ V} \end{aligned}$$

8 V

Mark allocation

- 1 mark for the correct answer.

Question 9

Calculate the voltage drop over the $50\ \Omega$ resistor.

1 mark

Worked solution

$$\begin{aligned} V &= I \times R \\ &= 0.08 \times 50 \\ &= 4\ \text{V} \end{aligned}$$

or

$$12\ \text{V} - 8\ \text{V} = 4\ \text{V}$$

4 V

Mark allocation

- 1 mark for the correct answer.

Sam argues that there is more current flowing through the $100\ \Omega$ resistor than the $50\ \Omega$ resistor, because it is closer to the power source.

Lilly states that there is more current going through the $50\ \Omega$ resistor than the $100\ \Omega$ resistor, because it is smaller.

Question 10

Who is correct? Sam? Lilly? Or neither? Explain your answer.

2 marks

Worked solution

- The current will be the same in both, because it is a series circuit. (1 mark)
- Sam and Lilly are both wrong. (1 mark)

Mark allocation

- 1 mark for each point.

The following information applies to questions 11 to 16.

Sam and Lilly modify their circuit, as shown in **Figure 3**.

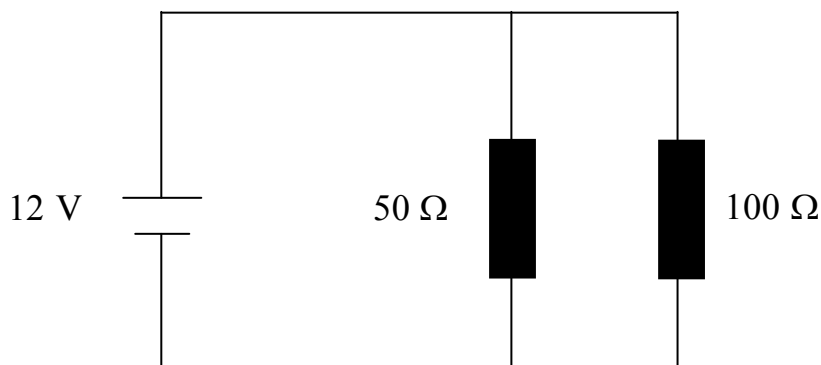

Figure 3

Question 11

What is the total resistance of the circuit shown in **Figure 3**?

2 marks

Worked solution

Parallel circuit:

$$R_T = (R_1^{-1} + R_2^{-1})^{-1}$$

$$= (50^{-1} + 100^{-1})^{-1}$$

$$R_T = 33.3 \, \Omega$$

33.3 Ω

Mark allocation

- 1 mark for correctly substituting values into the correct formula.
- 1 mark for the correct answer.

Question 12

What is the voltage drop across the 50 Ω resistor?

1 mark

Worked solution

The same as the power supply, i.e. 12 V.

12 V

Mark allocation

- 1 mark for the correct answer.

SECTION A – Area of Study 2– continued
TURN OVER

Question 13

What is the voltage drop across the 100 Ω resistor?

1 mark

Worked solution

The same as the power supply, i.e. 12 V.

12 V

Mark allocation

- 1 mark for the correct answer.

Question 14

Calculate the total current flowing from the power supply.

2 marks

Worked solution

$$I = \frac{V}{R}$$

$$= \frac{12}{33.3}$$

$$= 0.36 \text{ A}$$

0.36 A

Mark allocation

- 1 mark for correctly substituting values into the correct formula.
- 1 mark for the correct answer.

Question 15

Calculate the current flowing through the 100 Ω resistor.

2 marks

Worked solution

$$I = \frac{V}{R}$$

$$= \frac{12}{100}$$

$$= 0.12 \text{ A}$$

0.12 A

Mark allocation

- 1 mark for correctly substituting values into the correct formula.
- 1 mark for the correct answer.

Sam argues that there is more current flowing through the $50\ \Omega$ resistor than the $100\ \Omega$ resistor, because it is closer to the power source.

Lilly states that there is more current going through the $50\ \Omega$ resistor than the $100\ \Omega$, because it is smaller.

Question 16

Who is correct? Lilly or Sam? Explain your answer.

2 marks

Worked solution

In a parallel circuit, the current splits into the two resistors, with a greater current flowing through the smaller resistor. (1 mark)

Lilly is correct. (1 mark)

Mark allocation

- 1 mark for each correct point.

Question 17

Figure 4 shows a circuit that has a total resistance of $175\ \Omega$.

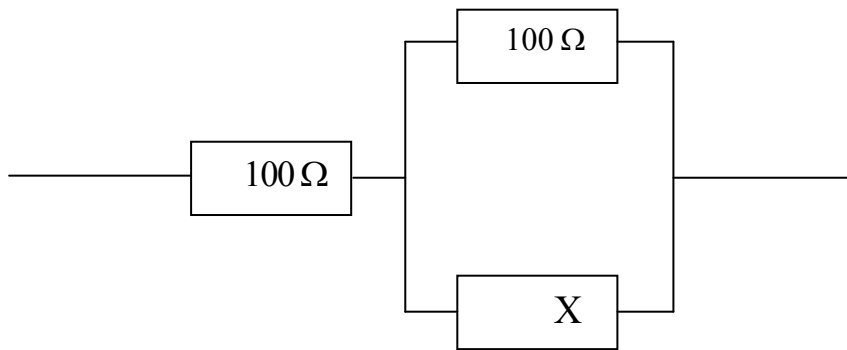

Figure 4

The value for X is

- A. $50\ \Omega$
- B. $75\ \Omega$
- C. $100\ \Omega$
- D. $300\ \Omega$

2 marks

D

Worked solution

Placing resistors in parallel gives:

$$R_T^{-1} = 100^{-1} + 300^{-1}$$

$$R_T = 0.0133^{-1}$$

$$= 75\ \Omega$$

Then add $100\ \Omega$ for the series, giving:

$$75\ \Omega + 100\ \Omega = 175\ \Omega, \text{ as required.}$$

Mark allocation

- 2 marks for the correct answer.

The following information applies to questions 18 and 19.

Rosco buys a heater that has a power rating of 2000 W. He plugs it straight into the mains, which is 240 V RMS.

Question 18

How much current will the heater draw?

2 marks

Worked solution

$$P = VI$$

$$I = \frac{P}{V}$$

$$= \frac{2000}{240}$$

$$= 8.33 \text{ A}$$

8.33 A

Mark allocation

- 1 mark for substituting values correctly into the correct formula.
- 1 mark for the correct answer.

Question 19

Rosco runs his heater for 3 hours per day, for 1 week. Electricity is charged at 24 cents per kWh. Calculate the cost (in dollars) of Rosco keeping warm.

2 marks

Worked solution

$$3 \text{ hours} \times 7 \text{ days} = 21 \text{ hours}$$

$$2 \text{ kW} \times 21 \text{ hours} = 42 \text{ kWh}$$

$$42 \text{ kWh} \times 0.24 \text{ cents} = \$10.08$$

\$10.08

Mark allocation

- 1 mark for substituting values correctly into the correct formula.
- 1 mark for the correct answer.

Question 20

Electricity meters in the home measure

- A. energy
- B. voltage
- C. power
- D. current

2 marks

A

Worked solution

People get charged for the amount of electrical energy that they use, *not* the characteristics of the supply. Although power is reliant on current (as voltage is set at 240 V), it is how much power *and* for how long that we are charged for.

Mark allocation

- 2 marks for the correct answer.

Question 21

Name **two** contributing factors that will affect the severity of the consequences for a person who receives an electric shock.

2 marks

Worked solution

Any two of:

- length of time person received shock
- how much current goes through the person
- the resistance of the person
- the path the current takes through the body, especially through the heart.

Mark allocation

- 1 mark for each correct answer, up to 2 marks.

END OF AREA OF STUDY 2

END OF SECTION A

END OF SECTION A

SECTION B – Detailed studies**Detailed study 1 – Astronomy****Question 1**

A group of stars, such as ‘The Big Dipper’ or ‘The Saucepan’, is called a

- A. galaxy
- B. constellation**
- C. cluster
- D. nebula

2 marks

Answer is B**Worked solution**

‘The Big Dipper’ and ‘The Saucepan’ are considered to be constellations.

A galaxy contains billions of stars, whereas a cluster is a few stars in close proximity to each other. Although stars in constellations may be spread far apart, they *appear* to be close together when viewed from Earth.

Question 2

Alpha Centauri is 4.3 light years from Earth. This distance equates to

- A. 1.29×10^9 m
- B. 4.1×10^{13} m
- C. 4.1×10^{13} km**
- D. 4.1×10^{10} m

2 marks

Answer is C**Worked solution**

One light year is the distance light travels in a year, which is

$$3 \times 10^8 \times 60 \times 60 \times 24 \times 365 \text{ m} = 9.5 \times 10^{12} \text{ km}$$

$$4.3 \times 9.5 \times 10^{12} \text{ km} = 4.1 \times 10^{13} \text{ km}$$

Question 3

Tomba likes to lie on his back and watch the Southern Cross for hours. He notices that it appears to be rotating around the South Celestial Pole. This is due to

- A. **diurnal motion**
- B. annual motion
- C. the Earth's motion around the Sun
- D. the stars' motion around the Earth

2 marks

Answer is A**Worked solution**

The Earth rotates on its axis, causing the stars' apparent motion, and is called diurnal motion. Annual motion is caused by the Earth's motion around the Sun.

Question 4

The term *heliocentric* literally means

- A. Earth motion
- B. Earth centred
- C. star centred
- D. **Sun centred**

2 marks

Answer is D**Question 5**

Galileo observed sunspots on the surface of the Sun and was able to conclude that the Sun rotated on an axis with a period of approximately

- A. **27 hours**
- B. 27 days
- C. 27 weeks
- D. 1 year

2 marks

Answer is A

Question 6

Ally is showing her brother a new telescope that she has borrowed. She explains to her brother that it has an objective lens with a focal length of 62 cm and an eyepiece with a focal length of 3.1 cm. When her brother asks what the magnification of the telescope is, Ally replies

- A. 20
- B. 0.05
- C. 192.2
- D. 5

2 marks

Answer is A**Worked solution**

$$\begin{aligned} M &= \frac{f_o}{f_e} \\ &= \frac{62}{3.1} \\ &= 20 \end{aligned}$$

**Tip**

- *Magnification does not have any units.*

Question 7

Two popular systems of mounting a telescope are

- A. **altazimuth and equatorial**
- B. altitude and azimuth
- C. altazimuth and altitude
- D. altitude and equatorial

2 marks

Answer is A

Question 8

The term *planet* literally means

- A. Earth like
- B. Sun orbiter
- C. **wandering star**
- D. moon companion

2 marks

Answer is C

Question 9

Dorothy is watching a spectacular sunrise from the banks of the Mitta Mitta River in north-east Victoria. She looks straight up and notices that the Moon is directly overhead. What type of moon is she looking at?

- A. full moon
- B. new moon
- C. **half moon waning**
- D. half moon waxing

2 marks

Answer is C

Question 10

Which of the following is the reason for Earth's seasons?

- A. **Earth's tilt on its axis**
- B. how close Earth is to the Sun
- C. the rotation of the Earth
- D. sunspot activity

2 marks

Answer is A

Worked solution

Although the Earth does differ in its proximity to the Sun as it orbits the Sun, this does not cause the seasons. Otherwise all of the Earth would have winter *at the same time*.

Detailed study 2 – Medical physics**Question 1**

A doctor needs 4 grams of a radiotracer to use in her hospital. If the radiotracer has a half-life of 4 hours, and takes 12 hours to deliver from the manufacturer, how much will the doctor need to order?

- A. 0.5 gram
- B. 2 grams
- C. 16 grams
- D. 32 grams

2 marks

Answer is D**Worked solution**

12 hours is 3 half-lives, so the sample will go from 32 g to 16 g in the first half-life, from 16 g to 8 g in the second half-life, and from 8 g to 4 g in the third, and final, half-life.

Question 2

The percentage of radiation that we are exposed to in our lives as a result of **human-made radiation** is approximately

- A. 15%
- B. 75%
- C. 85%
- D. 95%

2 marks

Answer is A**Worked solution**

Background radiation and radiation from the Sun far outweighs the amount of radiation we receive from a few X-rays and mobile phones etc.

Question 3

An ultrasound machine is delivering ultrasounds at 1.9 MHz, with a speed of 1600 m s^{-1} . What will be the wavelength (λ) of these waves?

- A. $8.42 \times 10^{-4} \text{ m}$
- B. 842 m
- C. $8.42 \times 10^8 \text{ m}$
- D. 1187 m

2 marks

Answer is A**Worked solution**

$$v = f\lambda$$

$$\lambda = \frac{v}{f}$$

$$= \frac{1600}{1.9 \times 10^6}$$

$$= 8.42 \times 10^{-4} \text{ m}$$

**Tip**

- Always convert any prefixes to SI units as early as possible. Make sure you are familiar with them all, especially k, m, M and μ .

Question 4

Which area of medical physics occurs as a result of radioactive decay?

- A. X-rays
- B. CT scans
- C. MRI scans
- D. PET scans

2 marks

Answer is D**Worked solution**

PET scans detect emissions from radioactive tracers that are injected into the human body.

Question 5

Which of the following instruments does not use a form of electromagnetic radiation?

- A. **ultrasound**
- B. X-ray
- C. CT scan
- D. lasers

2 marks

Answer is A**Worked solution**

Ultrasound uses sound waves. Lasers, X-rays and CT scans all use electromagnetic radiation.

Question 6

If an X-ray has a frequency of 5×10^{14} MHz, what is its period?

- A. 2×10^{-21} s
- B. 2×10^{19} s
- C. 2×10^{13} s
- D. 2×10^{-15} s

2 marks

Answer is A**Worked solution**

$$\begin{aligned} 5 \times 10^{14} \text{ MHz} &= 5 \times 10^{14} \times 10^6 \text{ Hz} \\ &= 5 \times 10^{20} \text{ Hz} \end{aligned}$$

$$\begin{aligned} \text{Period} &= \frac{1}{f} \\ &= \frac{1}{5 \times 10^{14} \times 10^6} \\ &= 2 \times 10^{-21} \text{ s} \end{aligned}$$

**Tip**

- Convert MHz to Hz before starting the problem.

Question 7

If an X-ray has a wavelength of 1.2×10^{-6} m, what is its frequency?

- A. 3.96×10^{-6} Hz
- B. 2.5×10^{14} Hz
- C. 2.5 Hz
- D. 2500 Hz

2 marks

Answer is B**Worked solution**

$$v = f\lambda$$

$$f = \frac{v}{\lambda}$$

$$= \frac{3 \times 10^8}{1.2 \times 10^{-6}}$$

$$= 2.5 \times 10^{14} \text{ Hz}$$

**Tip**

- The speed of any electromagnetic radiation will be $3 \times 10^8 \text{ m s}^{-1}$.

Question 8

A CT scan uses

- A. **X-rays**
- B. sound waves
- C. lasers
- D. optical fibres

2 marks

Answer is A**Worked solution**

CT scans take X-rays at all angles to produce a 3D picture.

Question 9

An endoscope needs its optical fibres to be coherent. The diagram below shows one end of an endoscope.

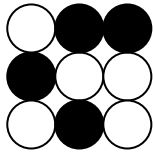

Which of the following is incoherent to the diagram shown above?

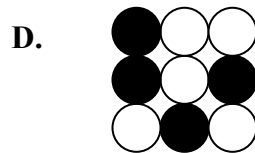
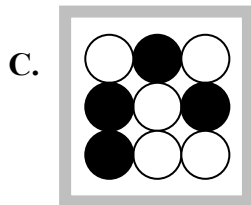
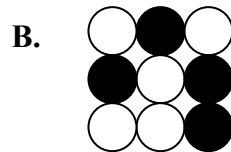
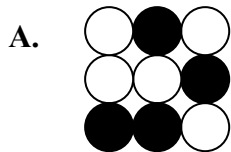

2 marks

Answer is C

Worked solution

Options A, B and D are simply rotations of the original.

Question 10

Which radiation is appropriate for diagnosis and therapy, respectively?

- A. α, β
- B. γ, α
- C. β, γ
- D. α, γ

2 marks

Answer is B

Worked solution

- For diagnosis, a radiation with a low quality factor is important, and a high penetrator is required for tracers.
- For therapy, a high quality factor is needed to kill unwanted cells, but a poor penetrator is required to restrict damage to the immediate area.

Detailed study 3 – Energy from the nucleus

Question 1

Which of the following statements about ${}_{92}^{235}\text{U}$ is correct?

- A. 143 protons, 92 neutrons and 235 nucleons
- B. 92 protons, 143 neutrons and 235 nucleons**
- C. 235 protons, 92 neutrons and 92 nucleons
- D. 92 protons, 235 neutrons and 92 nucleons

2 marks

Answer is B

Worked solution

nucleons	Symbol
protons	

neutrons = nucleons – protons

Question 2

Which of the following equations can occur in a typical nuclear power station?

- A. ${}_{92}^{235}\text{U} + {}_0^1\text{n} \rightarrow {}_{56}^{141}\text{Np} + {}_{36}^{92}\text{Kr} + 3{}_0^1\text{n}$
- B. ${}_{92}^{235}\text{U} + {}_0^1\text{n} \rightarrow {}_{56}^{141}\text{Np} + {}_{36}^{92}\text{Kr} + 2{}_0^1\text{n}$
- C. ${}_{92}^{235}\text{U} + {}_0^1\text{n} \rightarrow {}_{56}^{141}\text{Np} + {}_{36}^{91}\text{Kr} + 3{}_0^1\text{n}$
- D. ${}_{92}^{235}\text{U} + {}_0^1\text{n} \rightarrow {}_{56}^{141}\text{Np} + {}_{36}^{92}\text{Kr} + 3{}_0^1\text{n}$

2 marks

Answer is A

Worked solution

Uranium absorbs a neutron, which is ${}_0^1\text{n}$, and emits 3 neutrons. Then balance the top and bottom equations.

Question 3

What holds the nucleus of an atom together?

- A. gravitational force
- B. weak nuclear force
- C. strong nuclear force**
- D. electrostatic force

2 marks

Answer is C

Question 4

During World War II, the Americans, along with the British, developed the world's first atomic/nuclear bombs. The code name for this was

- A. **Manhattan Project**
- B. USA Atomic Commission
- C. NASA
- D. General Electric

2 marks

Answer is A

Question 5

The only nuclear bombs ever to be used against other people were the two dropped in World War II by the Americans. The blast killed over 150 000 people from the blast. Hundreds of thousands more were killed by radiation sickness in the years that followed. The bombs were dropped on which two cities?

- A. Tokyo and Hiroshima
- B. **Hiroshima and Nagasaki**
- C. Tokyo and Nagasaki
- D. Hiroshima and Kyoto

2 marks

Answer is B

Question 6

In a nuclear power station, ${}_{92}^{235}\text{U}$ needs a **slow neutron** to initiate fission. What slows down these neutrons?

- A. **a moderator**
- B. control rods
- C. fuel rods
- D. radiation shields

2 marks

Answer is A

Worked solution

Control rods absorb neutrons to slow down the chain reaction by limiting the number of neutrons available. Fuel rods supply the uranium, whereas radiation shields stop harmful radiation from escaping.

Question 7

In a nuclear power station, the role of the control rods is to

- A. **limit the number of neutrons available**
- B. control the temperature
- C. use the fuel
- D. make electricity

2 marks

Answer is A

Question 8

A fusion reaction may be found easily by

- A. going to NASA
- B. going to Russia
- C. going to England
- D. **looking up at the stars**

2 marks

Answer is D

Question 9

Fusion reactors are not used today because

- A. fission is more environmentally friendly
- B. **they are too expensive to build and run**
- C. fuel is cheap
- D. they have less radioactive waste

2 marks

Answer is B

Worked solution

Fusion is currently unviable because of the enormous costs of the high temperature and pressure needed.

Question 10

Australia has

- A. no nuclear reactors and no nuclear power plants
- B. nuclear reactors and nuclear power plants
- C. **nuclear reactors but no nuclear power plants**
- D. nuclear power plants but no nuclear reactors

2 marks

Answer is C

Worked solution

Two nuclear reactors in Lucas Heights, New South Wales, provide research and medical material.

Detailed study 4 – Astrophysics**Question 1**

The correct name of the closest star to Earth is

- A. Sun
- B. Sol
- C. Helios
- D. Solar

2 marks

Answer is A

Worked solution

The Sun doesn't have a 'real' star name like Alpha Centauri does.

Question 2

If an astronomer observes a star undergoing a Doppler effect into red shift, then that star is travelling

- A. towards us
- B. away from us
- C. parallel to us
- D. at right angles to us

2 marks

Answer is B

Worked solution

For a star travelling away from us, light reaching Earth will appear to have a longer wavelength than usual. Red light has a longer wavelength than other light.

Question 3

Billions of stars that are in close proximity to each other, orbiting a central point are called a

- A. constellation
- B. galaxy
- C. nebula
- D. cluster

2 marks

Answer is B

Worked solution

A galaxy contains billions of stars, whereas a cluster has a few stars in close proximity to each other. Although stars in a constellation may be spread far apart, they *appear* to be close together when viewed from Earth.

This page is blank

Question 4

The brightness level of a star is **not** due to

- A. its proximity to the Earth
- B. the size of the star
- C. the quantity of light emitted
- D. **the colour of the star**

2 marks

Answer is D

Worked solution

Colour is closely related to the temperature of the star, *not* its brightness.

Question 5

The universe is

- A. getting smaller as gravity pulls everything together
- B. getting bigger but its expansion is slowing down
- C. **getting bigger and accelerating out as it does so**
- D. in a steady state

2 marks

Answer is C

Worked solution

Strangely, to date, no-one has determined the reason why, and proved it. Research into dark matter and string theory is continuing.

Question 6

The Milky Way is what shape?

- A. elliptical
- B. **spiral**
- C. irregular
- D. delicious

2 marks

Answer is B

Worked solution

The shape of the Milky Way galaxy is spiral.

Question 7

Which of the following are **not** regions of a Hertzsprung–Russell diagram?

- A. giants
- B. supergiants
- C. main sequence
- D. **red dwarfs**

2 marks

Answer is D**Worked solution**

White dwarfs have a region, but red dwarfs do not.

Question 8

Astronomers in the 18th century knew that the universe was finite because

- A. **the night sky was dark**
- B. they knew of galaxies
- C. of advances in the telescope during this time
- D. of the size of the Sun

2 marks

Answer is A**Worked solution**

If the universe was infinitely big, everywhere you looked in the night sky would hold a star, and the night would not be dark.

Question 9

The Big Bang has been calculated to have occurred

- A. 5000 years ago
- B. 4 billion years ago
- C. 4 million years ago
- D. **14 billion years ago**

2 marks

Answer is D

Question 10

The theory of the Steady State Universe was discounted in the mid 1960s with the discovery of which of the following in the background from the Big Bang?

- A. microwaves**
- B. X-rays**
- C. ultraviolet rays**
- D. infrared rays**

2 marks

Answer is A**Worked solution**

If you turn on your TV to an un-tuned channel, some of the static produced is from the radiation from the Big Bang.

This page is blank

Detailed study 5 – Investigations: Flight**Question 1**

In which of these scenarios is the aircraft **not** going to crash?

- A. When the aircraft reaches a point called the critical angle of attack
- B. When an aircraft travelling at a top speed of 100 km h^{-1} meets a headwind of 100 km h^{-1} .**
- C. When an aircraft travelling at a top speed of 100 km h^{-1} has a tailwind of 100 km h^{-1} .
- D. When the skin friction drag and the pressure drag exceeds thrust

2 marks

Answer is B

Worked solution

An aircraft travelling at 100 km h^{-1} with a tailwind of 100 km h^{-1} will have zero wind speed.

Question 2

The mathematical relationship between the distance an aircraft will glide forward to the altitude loss is known as

- A. glide ratio**
- B. lapse ratio
- C. aspect ratio
- D. adiabatic ratio

2 marks

Answer is A

Question 3

An aeroplane in flight is shown below.

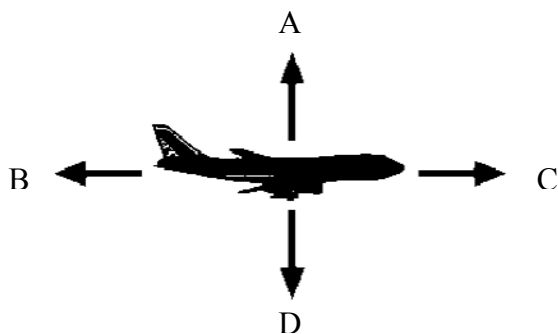

Which of the following correctly describes the forces on this aircraft?

- A. A is thrust, B is drag, C is lift, D is weight.
- B. A is lift, B is weight, C is thrust, D is drag.**
- C. A is weight, B is thrust, C is drag, D is lift.
- D. A is lift, B is drag, C is thrust, D is weight.

2 marks

Answer is D

Question 4

For an aircraft travelling at a constant velocity

- A. all forces must be equal
- B. thrust is equal to drag, lift is greater than weight
- C. lift is greater than weight, thrust is greater than drag
- D. **the sum of all forces equals zero**

2 marks

Answer is D

Worked solution

All forces will not have to be equal, as drag and lift may be completely different.

Question 5

Who was a great artist, an architect, and a man of science and conducted the first scientific experiments in the field of aviation?

- A. Joseph Montgolfier
- B. **Leonardo da Vinci**
- C. Oliver Wright
- D. Wilbur Wright

2 marks

Answer is B

Question 6

Match the following motions to their proper axes.

- A. Motion about the vertical axis is yaw; motion about the longitudinal axis is pitch; and motion about the lateral axis is roll.
- B. **Motion about the lateral axis is pitch; motion about the vertical axis is yaw; and motion about the longitudinal axis is roll.**
- C. Motion about the lateral axis is roll; motion about the vertical axis is pitch; and motion about the longitudinal axis is yaw.
- D. Motion about the lateral axis is pitch; motion about the vertical axis is yaw; and motion about the horizontal axis is roll.

2 marks

Answer is B

Question 7

Sir Isaac Newton gave us three laws of motion. Of the following, which one applies to an aeroplane in flight?

- A. A body at rest will remain at rest unless acted upon by some outside force.
- B. A force acting upon a body causes it to accelerate in the direction of the force. Acceleration is directly proportional to the force and inversely proportional to the mass of the body being accelerated.
- C. For every action there is an equal and opposite reaction.
- D. **All of these answers are correct.**

2 marks

Answer is D

Question 8

Which of the following correctly shows yaw, pitch and roll?

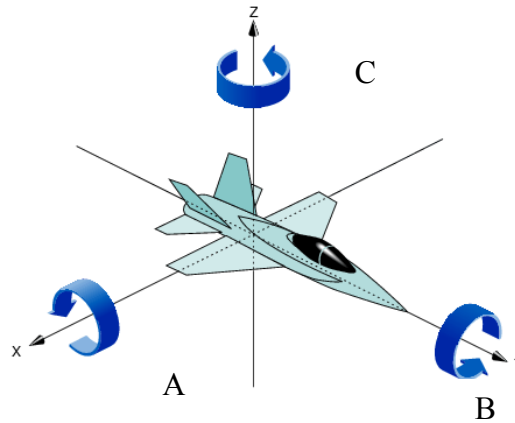

- A. A = yaw, B = pitch, C = roll
- B. A = pitch, B = yaw, C = roll
- C. A = roll, B = pitch, C = yaw
- D. **A = pitch, B = roll, C = yaw**

2 marks

Answer is D

Question 9

Bernoulli's principle is used to describe lift with the wings of an aircraft.

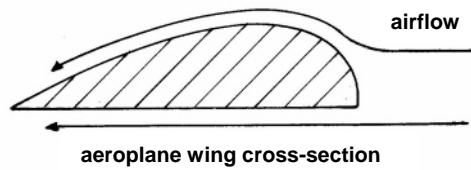

The wing produces lift because

- A. the air is moving faster over the top of the wing, creating a lower air pressure, which sucks the wing up.
- B. the air is moving faster over the top of the wing, creating a higher air pressure, which pushes the wing up.
- C. the air is moving slower over the bottom of the wing, creating a lower air pressure, which sucks the wing up.
- D. the air is moving slower over the bottom of the wing, creating a higher air pressure, which pushes the wing up.**

2 marks

Answer is D

Worked solution

Things don't get 'sucked' due to a difference in air pressure; they get pushed by the higher pressure. Even a vacuum cleaner doesn't 'suck'; instead the air around the dirt pushes it in.

Question 10

A four-engine plane has identical engines that are delivering a force of 10 000 newtons of force each. The outside engines are 8 metres from the centre of the plane, and the inner engines are 5 metres from the centre of the plane. Suddenly, the right inner engine cuts out. At what force should the outside right engine now deliver so that the plane remains in a straight line?

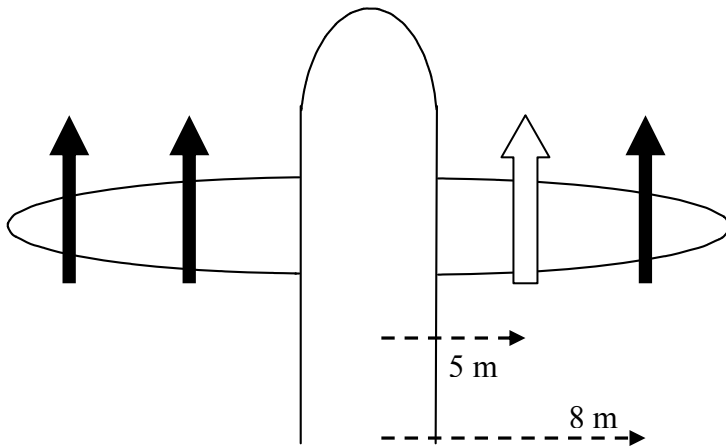

- A. 6300 N
- B. **16 300 N**
- C. 2000 N
- D. 26 000 N

2 marks

Answer is B**Worked solution**

$$\begin{aligned} \sum (F \times r)_{\text{left}} &= \sum (F \times r)_{\text{right}} \\ 10000 \times 8 + 10000 \times 5 &= F \times 8 \\ 130000 &= F \times 8 \\ F &= \frac{130000}{8} \\ &= 16300 \text{ N} \end{aligned}$$

**Tip**

- *There must be equal torques on both sides; otherwise rotation will occur.*

Detailed study 6 – Investigations: sustainable energy sources**Question 1**

Which of the following is a sustainable energy source?

- A. nuclear energy
- B. natural gas
- C. petroleum
- D. solar

2 marks

Answer is D**Worked solution**

At least while the Sun shines, which it will for billions of years.

Question 2

Rob has put together 12 solar cells, each producing 12 V at 20 mA each.
How much power can Rob harness?

- A. 240 W
- B. 2880 W
- C. **2.88 W**
- D. 0.24 W

2 marks

Answer is C**Worked solution**

Each cell:

$$P = VI$$

$$= 12 \times 20 \times 10^{-3}$$

$$= 0.24 \text{ W}$$

$$\therefore 12 \text{ cells produce } 0.24 \times 12 = 2.88 \text{ W}$$

Question 3

Miriam has a heater that is only 20% efficient. If she needs it to have an output of 500 W to warm her toes, then the heater must have an input of

- A. 400 W
- B. 1400 W
- C. **2500 W**
- D. 4000 W

2 marks

Answer is C**Worked solution**

20% of 2500 W = 500 W

Question 4

Which one of the following is not a cause of climate change gases?

- A. wood fires
- B. deforestation
- C. herds of cattle
- D. **nuclear power plants**

2 marks

Answer is D**Worked solution**

Nuclear power plants have a lot of other negatives, however they are not a cause of climate change. Herds of cattle produce enormous amounts of methane.

Question 5

Which one of the following forms of energy conversion does **not** require a turbine for creating electricity?

- A. nuclear power
- B. wind power
- C. hydro power
- D. **solar power**

2 marks

Answer is D**Worked solution**

Solar panels produce electricity without the need for a turbine. The others convert mechanical energy to electrical energy through a turbine.

Question 6

Of the following, which does **not** influence the amount of solar power being produced?

- A. **temperature**
- B. insolation
- C. panel area
- D. efficiency of panels

2 marks

Answer is A

Question 7

A house uses twelve 100 W light globes for an average of 5 hours per day for each globe. The inhabitants change to 15 W energy-efficient light globes.

If electrical energy costs \$0.24 per kWh, how much will they save in 1 year?

- A. \$525.60
- B. \$78.84
- C. **\$446.76**
- D. \$604.44

2 marks

Answer is C

Worked solution

Cost for 1 year:

Lights use 1.2 kW per hour, so

$$1.2 \text{ kW} \times 5 = 6 \text{ kWh per day}$$

$$6 \times 365 = 2190 \text{ kWh per year}$$

$$2190 \times \$0.24 = \$525.60$$

New lights use 85% less:

$$85\% \text{ of } \$525.60 = \$446.76$$

Question 8

A hydropower station is built so that the water falls 50 metres and can handle 40 000 litres per second. Theoretically, how much power is possible?

- A. 20 MW
- B. 2 MW
- C. 0.2 MW
- D. 200 MW

2 marks

Answer is A**Worked solution**

Each litre of water has a gravitational potential energy of 500 J (mgh).

So, 40 000 litres per second will give $500 \times 40\,000$ W.

$$= 2 \times 10^7 \text{ W}$$

$$= 20 \times 10^6 \text{ W}$$

$$= 20 \text{ MW}$$

Question 9

As energy converts from one form to another, some energy will be lost. This energy is lost as

- A. mechanical energy
- B. light energy
- C. heat energy
- D. electrical energy

2 marks

Answer is C**Worked solution**

Most is lost as heat through friction.

Question 10

In a hydroelectrical power plant, the energy transfer that occurs is

- A. **gravitational potential energy** → kinetic energy → electrical energy
- B. gravitational potential energy → heat → kinetic energy → electrical energy
- C. kinetic energy → gravitational potential energy → electrical energy
- D. kinetic energy → gravitational potential energy → heat → electrical energy

2 marks

Answer is A**Worked solution**

Water starts up high (gravitational potential energy), then increases speed on the way down (kinetic energy), and then turns a turbine (electrical energy).

END OF SOLUTIONS BOOK