



Online & home tutors Registered business name: itute ABN: 96 297 924 083

PHYSICS

2017

Trial Examination

(2 hours 30 minutes)

<i>Section</i>	<i>Number of questions</i>	<i>Number of questions to be answered</i>	<i>Number of marks</i>
A	20	20	20
B	18	18	110
			Total 130

(Note: Use the formula/data sheets supplied by VCAA)

SECTION A –20 Multiple-choice questions (20 marks)

Instructions for Section A

Answer **all** questions in this section.

Choose the response that is **correct** or that **best answers** the question.

A correct answer scores 1; an incorrect answer scores 0.

Marks will **not** be deducted for incorrect answers.

No marks will be given if more than one answer is completed for any question.

Unless otherwise indicated, the diagrams are **not** drawn to scale.

Take the value of g to be 9.80 N kg^{-1} .

Question 1

Which one of the following diagrams shows the electric field pattern in the region between a positively charged metal sphere and a negatively charged flat metal plate?

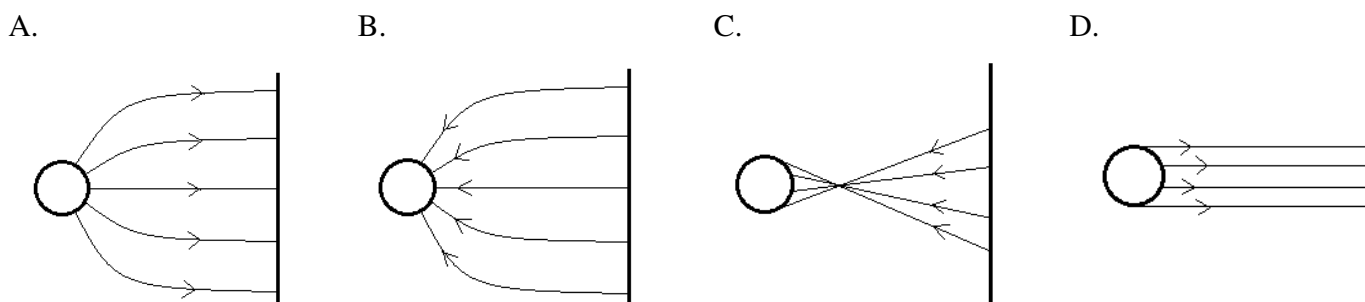

Question 2

An electric current flows to the north in a straight wire at the equator of Earth. The magnitude of the magnetic field generated by the current is about the same as that of Earth. A compass needle is placed on top of the wire. Which one of the following diagrams shows the orientation of the compass needle?

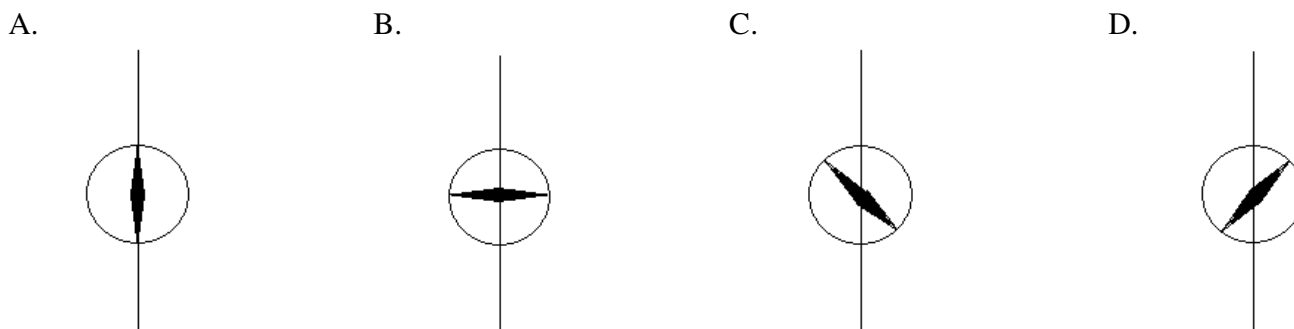

Question 3

A charged subatomic particle moves towards the surface of Earth from space. Which of the following statements is correct?

- A. The electric field, the magnetic field and the gravitational field exert the same force on the particle.
- B. The electric field exerts the strongest force on the particle than the magnetic field or gravitational field.
- C. The magnetic field exerts the strongest force on the particle than the gravitational field or electric field.
- D. The gravitational field exerts the strongest force on the particle than the electric field or magnetic field.

Question 4

The force of gravity between two objects at a distance apart is G newtons. If the mass of each object is halved and their distance apart is also halved, the force of gravity (in newtons) between them is given by

- A. $16G$
- B. $8G$
- C. $4G$
- D. G

Question 5

The charge on a tiny metal sphere is a half of the charge on another identical metal sphere placed 20 cm from it. The repulsive force between them is 1.0×10^{-6} N. The total charge (in C) of the two metal spheres is closest to

- A. 8.9×10^{-18}
- B. 1.3×10^{-17}
- C. 3.0×10^{-9}
- D. 4.5×10^{-9}

Question 6

A student investigates the magnitude of the sliding friction (F_f) when a rectangular block of mass (m) is placed on a plane inclined at an angle (θ) to the horizontal.

Which one of the following quantities is **not** a possible independent variable?

- A. m
- B. θ
- C. F_f
- D. the roughness of the plane surface

Question 7

A student investigates the magnitude of the sliding friction (F_f) when the rectangular block of mass (m) is placed on the plane inclined at an angle (θ) to the horizontal.

Which one of the following quantities is **not** a possible controlled variable?

- A. m
- B. θ
- C. F_f
- D. the roughness of the plane surface

Question 8

A student investigates the effects of changing the mass (m) of the rectangular block on the magnitude of the sliding friction (F_f) when the rectangular block is placed on a plane inclined at an angle (θ) to the horizontal.

Which one of the following quantities is an independent variable?

- A. m
- B. θ
- C. F_f
- D. the roughness of the plane surface

Question 9

A student measures the sides of a triangle.

The recorded measurements are: 12.5 m (3 significant figures), 0.78 m (2 sig. fig.), and 11.905 m (5 sig. fig.)
Which one of the following calculated values best represents of the perimeter (in metres) of the triangle determined by the student?

- A. 25
- B. 25.2
- C. 25.19
- D. 25.185

Question 10

A student finds the area of a circular loop by measuring its radius.

The measured radius is recorded as 3.28 cm and the estimated uncertainty by the student is 0.1 cm.

Which one of the following calculated values best represents of the area (in cm^2) of the loop determined by the student?

- A. 34 ± 2
- B. 34 ± 1
- C. 33.8 ± 0.2
- D. 33.8 ± 0.1

Question 11

The acceleration-time graph of a crash-test dummy's head (approximately 8 kg) when it collides with an airbag is shown below.

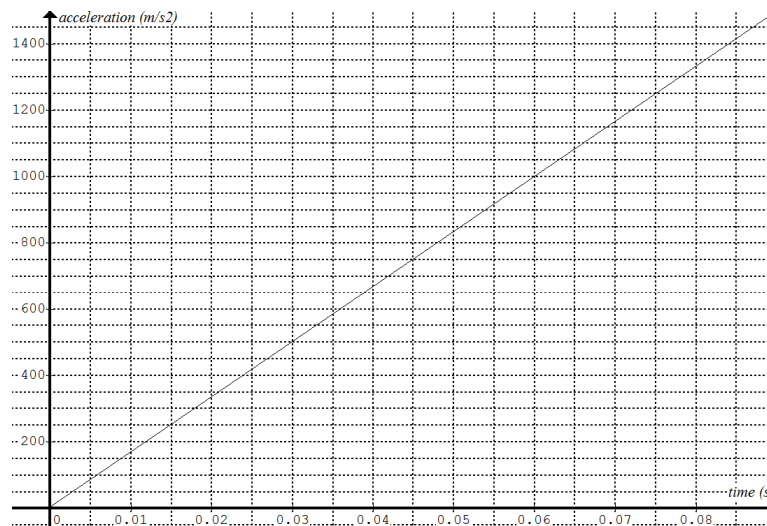

The decrease in momentum (kg m s^{-1}) of the crash-test dummy's head in the first 0.05 s of the collision is closest to

- A. 1.7×10^4
- B. 1.7×10^2
- C. 42
- D. 21

Use the following information to answer Questions 12 and 13

Relative to Earth, spacecraft A and B travel in opposite directions with velocities v_A and v_B respectively.



Question 12

Which one of the following statements is correct?

- A. A stationary observer on Earth measures the proper length of spacecraft B.
- B. A stationary observer in spacecraft A measures the proper length of spacecraft B.
- C. A stationary observer in spacecraft B measures the proper length of the Earth's equator.
- D. An observer in spacecraft B measures the length of spacecraft A to be shorter than that measured by a stationary observer on Earth.

Question 13

Which one of the following statements is correct about the time taken for spacecrafts A and B to meet?

- A. A stationary observer in spacecraft A measures a longer time than a stationary observer in spacecraft B.
- B. A stationary observer in spacecraft A measures a shorter time than a stationary observer in spacecraft B.
- C. A stationary observer in spacecraft A measures the same time as a stationary observer in spacecraft B.
- D. A stationary observer on Earth measures the longest time taken.

Use the following information to answer Questions 14 and 15

One end of a very long stretched elastic cord is shaken five times in two seconds. The following diagram shows the appearance of the cord at the end of the two seconds. A dot labeled as P is marked on the cord.

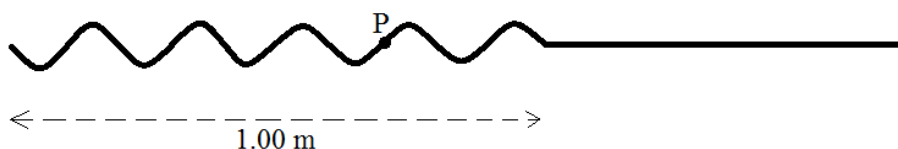

Question 14

At the moment shown in the diagram above, dot P is

- A. motionless
- B. moving forwards
- C. moving upwards
- D. moving downwards

Question 15

At the moment shown in the diagram above, the speed (m s^{-1}) of dot P is

- A. 0
- B. 0.5
- C. 1.0
- D. not determinable without more information

Question 16

Errors occur in scientific investigations.

When taking a measurement the possible sources of error are due to: (I) reading the wrong value, (II) the measuring instrument not 'zeroed', (III) the imprecision of the available instrument and (IV) difficulty in defining the dimensions of the object.

To estimate the uncertainty of a measured quantity a student should include errors due to

- A. (I) and (III)
- B. (II) and (IV)
- C. (III) and (IV)
- D. (I), (II), (III) and (IV)

Question 17

A photon and an electron interact in three possible ways. They are: (I) the photon is scattered by the electron without losing energy, (II) the photon is scattered by the electron with some energy loss, (III) the energy of the photon is completely 'absorbed' by the electron.

When light is directed at a piece of metal the possible event(s) is/are

- A. (III) only
- B. (I) and (II) only
- C. (I) and (III) only
- D. (I), (II) and (III)

Question 18

Which of the following statement is **incorrect** about internal reflection of light?

- A. Internal reflection can occur when light travels from one medium to a different medium.
- B. Internal reflection can occur at any angle of incidence between 0° and 90° .
- C. Internal reflection occurs only when the angle of incidence is equal to or greater than the critical angle.
- D. Internal reflection varies in intensity depending on the angle of incidence.

Question 19

Which one of the following quantities does not affect the acceleration of a satellite in circular orbit around Earth?

- A. Radius of the satellite orbit
- B. Mass of the satellite
- C. Mass of Earth
- D. Period of the satellite

Question 20

Which one of the following statements **cannot be true** in an **inelastic** collision of objects A and B?

- A. The total kinetic energy immediately after collision is greater than that immediately before collision.
- B. The total kinetic energy immediately after collision is less than that immediately before collision.
- C. The total momentum immediately after collision is equal to that immediately before collision.
- D. The change in momentum of object A equals the change in momentum of object B immediately after collision.

SECTION B

Instructions for Section B

Answer **all** questions in this section.

Where an answer box is provided, write your final answer in the box.

If an answer box has a unit printed in it, give your answer in that unit.

In questions where more than one mark is available, appropriate working **must** be shown.

Unless otherwise indicated, the diagrams are **not** drawn to scale.

Take the value of g to be 9.80 N kg^{-1} .

Question 1

An atomizer sprays a fine mist of spherical oil droplets. The radius of one of the droplets is $1.37 \pm 0.02 \mu\text{m}$.

- a. Calculate the volume (including uncertainty) V of the oil droplet, given $V = \frac{4}{3}\pi r^3$. 2 marks

- b. Find the mass (including uncertainty) m of the oil droplet given $m = DV$ and $D = 922.35 \text{ kg m}^{-3}$. 2 marks

The oil droplet enters a region of constant electric field between two horizontal metal plates separated by a distance of 16.0 mm.

The oil droplet is motionless when the potential difference between the two plates is 391.49 volts.

- c. Calculate the value of the constant electric field (including unit) between the two metal plates. 2 marks

d. Calculate the total amount of charge on the oil droplet.

2 marks

e. Determine the number of excess electrons on the oil droplet.

1 mark

f. When the number of excess electrons is reduced by one, explain the direction of motion of the oil droplet.

2 marks

Question 2

A 100-gram solid metal sphere is dropped from a certain height above a lake at $t = 0$.

It enters the water and sinks to the bottom of the lake. The velocity-time graph of the ball bearing is shown below.

Take the direction of motion of the ball bearing as the positive direction. The graph is made up for this question.

It may/may not represent a real situation.



a. Estimate the depth of the lake.

3 marks

m

b. Estimate the net force on the ball bearing at $t = 5.5$ s. Include the direction in your answer.

3 marks

N

c. Estimate the air resistance on the ball bearing at $t = 5.5$ s.

1 mark

N

Question 3

The 100-gram metal sphere is catapulted at an angle of 60° above the horizontal and it is 2.0 m above the ground at the start of its flight.

It has an initial kinetic energy of 20.0 J after leaving the catapult.

Assume that gravitational potential energy is zero at ground level.

Ignore air resistance in this question.

- a. Find the speed of the sphere at the start of its flight. 2 marks

m s^{-1}

- b. Find the kinetic energy of the sphere when it is at its highest point. 2 marks

J

- c. Find the total energy (kinetic + potential) of the sphere while it is in flight. 2 marks

J

- d. Find the time of flight of the ball bearing. 2 marks

s

Question 4

Two people of the **same** mass sit on opposite sides of a rotating circular platform without sliding. Person A is 4.20 m horizontally from the axis of rotation, and Person B is 2.10 m away. Consider a person as a point.

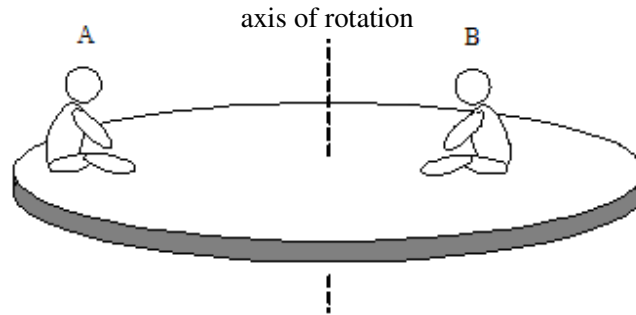

- a. Determine the value of the ratio $\frac{\text{speed of Person A}}{\text{speed of Person B}}$. 2 marks

- b. If the time for a complete rotation of the platform is 5.0 s, determine the value of the ratio

$\frac{\text{force of friction on Person A}}{\text{force of friction on Person B}}$. 3 marks

Question 5

Two artificial satellites of the **same** mass are in circular orbits around Earth.

Satellite A has a 42000 km orbital radius centred at the Earth's centre, and Satellite B has a 21000 km orbital radius.

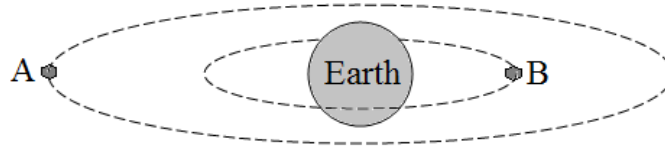

a. Determine the value of the ratio $\frac{\text{speed of Satellite A}}{\text{speed of Satellite B}}$.

3 marks

b. Determine the value of the ratio $\frac{\text{force of gravity on Satellite A}}{\text{force of gravity on Satellite B}}$.

2 marks

The graph of gravitational field strength g (N kg^{-1}) versus orbital radius r (m) is shown below.

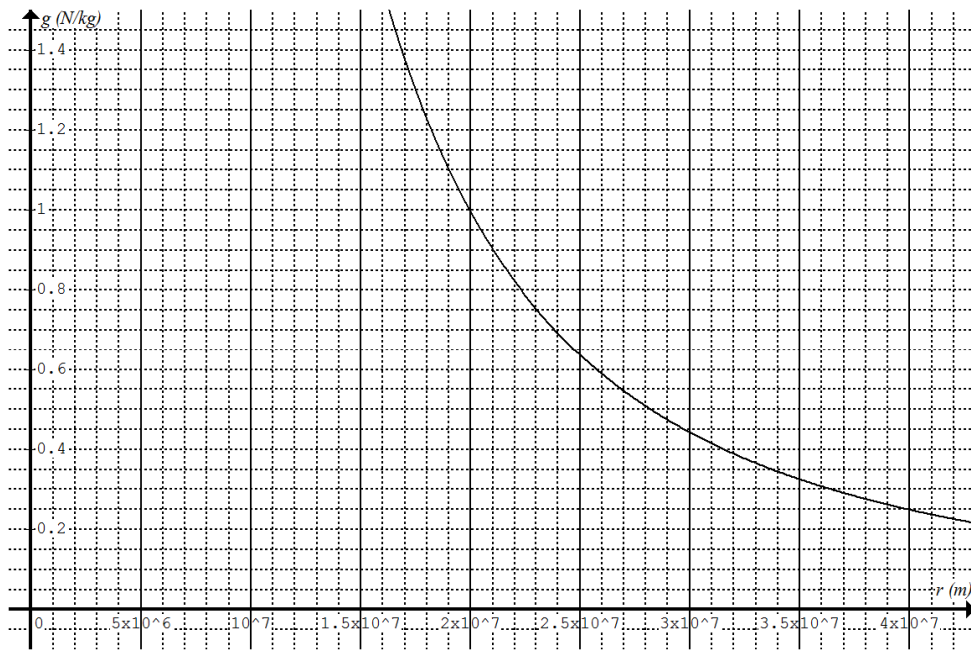

c. Estimate the **difference** in weight (N) per kg of the satellites in the two orbits.

2 marks

N

d. Estimate the **difference** in gravitational potential energy (J) per kg of the satellites in the two orbits. 3 marks

J

Question 6

A space station is measured to be 50.0 m long by an astronaut at the space station.

The astronaut at the space station measured the length of an approaching 30.0 m long spaceship to be 25.0 m.

- a. Determine the length of the space station measured by an astronaut in the space ship. 2 marks

m

- b. Determine the relative speed of the spaceship and the space station. 2 marks

m s^{-1}

- c. The time taken (measured by the astronaut at the space station) for the spaceship to arrive at the space station is 0.117 s.

Determine the time taken (measured by the astronaut in the spaceship) for the spaceship to reach the space station. 2 marks

s

Question 7

An electron (mass 9.1×10^{-31} kg, charge -1.6×10^{-19} C) and an alpha particle (${}^4_2\text{He}$) enter a region of uniform magnetic field of strength 0.020 tesla. The direction of motion of both particles is perpendicular to the magnetic field. The path of the electron is circular with a radius of 0.017 m. The path of the alpha particle is also circular but its radius is 0.17 m. Ignore relativistic effects.

a. Calculate the acceleration of the electron due to the magnetic force.

2 marks

b. Calculate the value of the ratio $\frac{\text{momentum of the alpha particle}}{\text{momentum of the electron}}$ when they first enter the magnetic field.

2 marks

Question 8

Electricity is transmitted over a long distance at high voltage through transmission line. The total resistance of the transmission line is 40Ω . At the power station end of the line the voltage is $50000 V_{\text{RMS AC}}$. At the town end of the transmission line the voltage is $49400 V_{\text{RMS AC}}$.

a. Calculate the total power loss in the transmission line.

3 marks

b. At the town end a step-down transformer is used to reduce the voltage to $240 V_{\text{RMS AC}}$.

Determine the value of the ratio $\frac{N_{\text{primary}}}{N_{\text{secondary}}}$ of the step-down transformer.

1 mark

Question 9

A student has a tungsten filament light globe (100 W 120 V).

She wants to find out whether it is an ohmic conductor.

She designs an experiment using the school laboratory apparatus. She uses a voltmeter to measure the voltage applied across the light globe and an ammeter to measure the resulting current in the circuit.

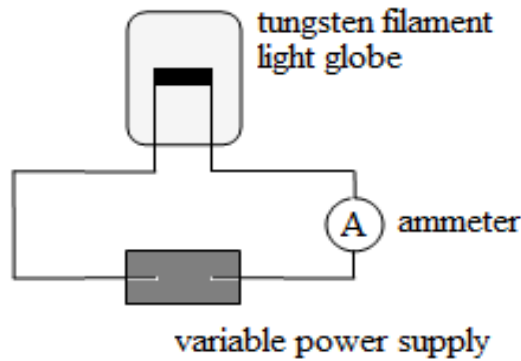

a. Shown on the diagram above the correct way to connect a voltmeter V to measure the voltage across the light globe.

1 mark

b. Identify the independent variable in this experiment.

1 mark

The measurements are recorded in the table below.

Voltage $V \pm 0.05 \text{ V}$	Current $I \pm 0.01 \text{ A}$
4.00	0.39
6.00	0.59
8.00	0.78
10.00	0.98
12.00	1.18

c. Plot the data on the following grid with the independent variable on the horizontal axis. Include uncertainties, axis labels and units.

5 marks

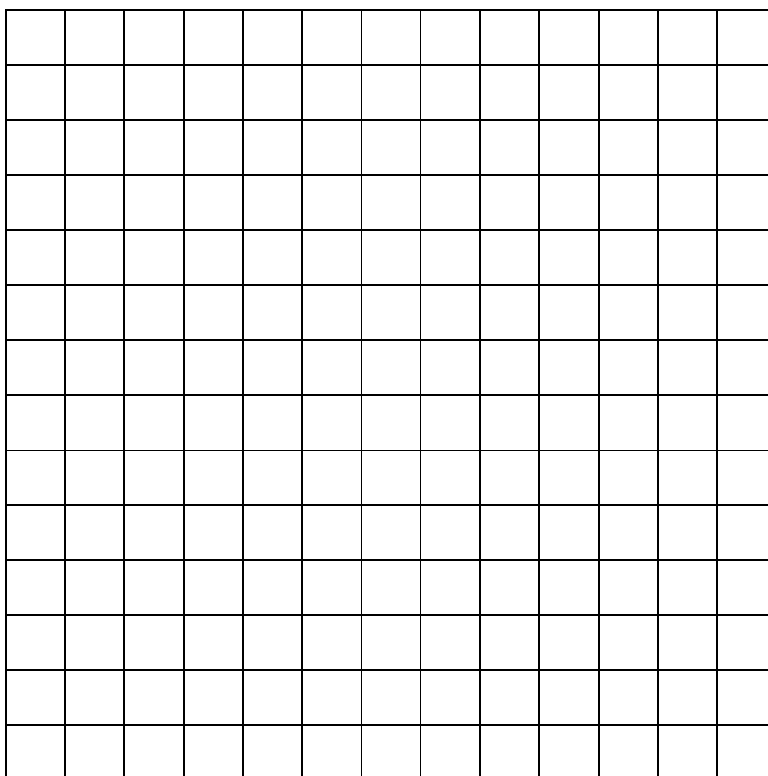

d. Can the student make a valid **general** conclusion from her data whether the tungsten filament light globe is an ohmic conductor? Explain your answer with relevant calculations.

3 marks

Question 10

The diagram shows a circular conducting coil of two turns placed in a uniform magnetic field of 0.020 tesla. The area of the plane enclosed by the coil is 100 cm². Initially (at $t = 0$) the magnetic field is perpendicular to the plane of the coil. The coil is made to rotate anticlockwise (viewed from above) at constant speed. The frequency of rotation is 5 Hz. The ends of the coil are labeled as A and B as shown in the diagram below.

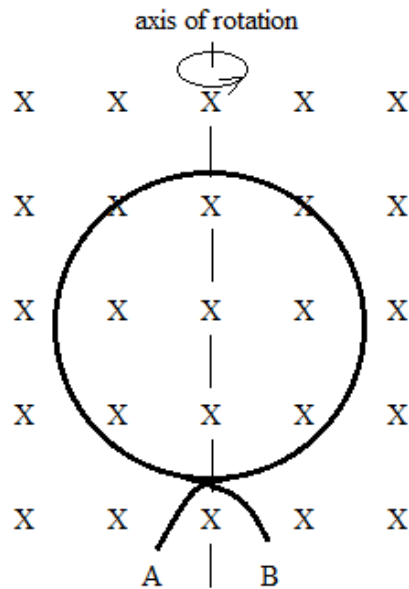

- a. Draw a graph of magnetic flux ϕ (wb) through the coil versus time t (s), showing 2 cycles. 3 marks

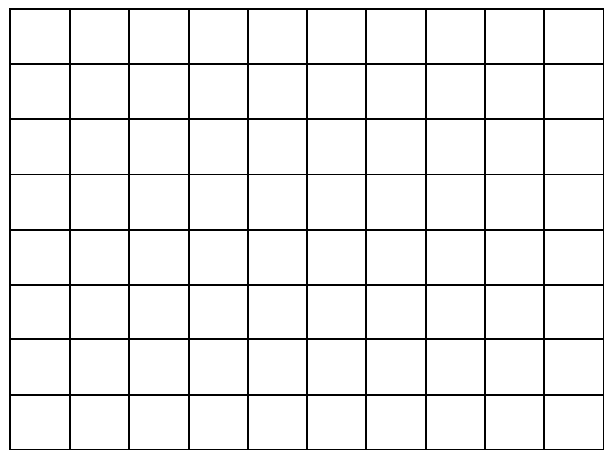

- b. The circular conducting coil rotating in the uniform magnetic field can be considered as an alternator. Determine the polarity (i.e. + or -) of end A after turning 120° from its initial orientation. Explain your answer. 2 marks

Question 11

A stretched straight elastic cord is shaken **in phase** periodically at its ends by two identical vibrators. You can assume the ends of the cord are displacement nodes.

Each vibrator generates five complete waves ($\lambda = 0.080\text{ m}$) in one second, causing the cord to resonate. There are six displacement nodes (including the end nodes) appeared in the cord.

Let M be the midpoint of the elastic cord.

a. Describe the motion of a particle of the cord a half of a wavelength on each side of M. 2 marks

b. Calculate the speed of the travelling waves in the cord. 2 marks

c. Calculate the difference in distances of the second displacement node on the left of M from each end of the elastic cord. 2 marks

d. Determine the lowest natural frequency of vibration of the cord. 2 marks

Question 12

The sun appears orange/red when the air is filled with smoke particles. Explain this phenomenon in terms of diffraction of light.

3 marks

Question 13

The refractive indices of two transparent substances are 1.52 and 1.30 for blue light.

a. Determine the critical angle for blue light when it passes from one substance into the other substance.

2 marks

b. A beam of blue light is directed at the interface of the two substances from the side of higher refractive index at an angle of incidence of 50.5° . Determine the angle of reflection and the angle of refraction.

1 + 2 = 3 marks

--	--

Question 14

The following graph is drawn using data from a photoelectric effect experiment. The maximum kinetic energy of the photoelectrons is measured in an arbitrary unit (ρ).

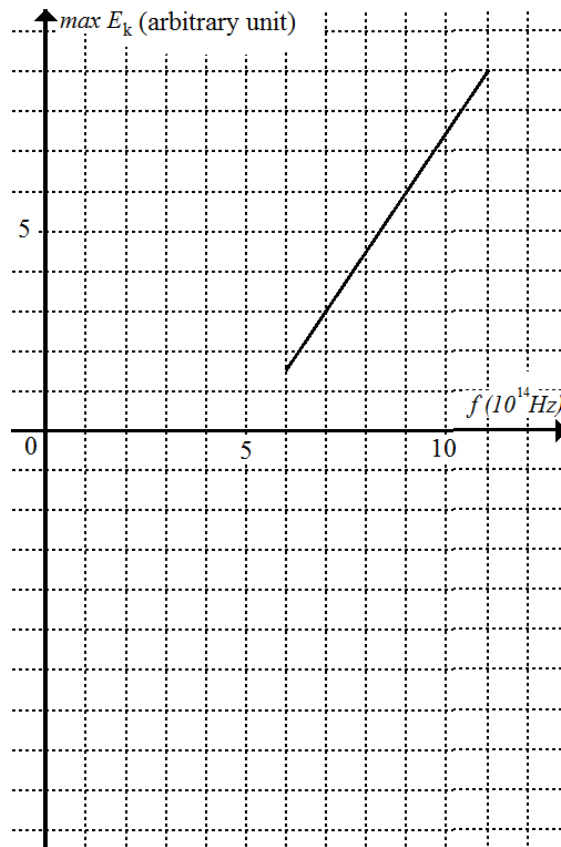

a. Estimate the threshold frequency for the metal used in the experiment.

1 mark

 Hz

b. Estimate the work function of the metal used in the experiment.

1 mark

 ρ

c. Another metal has a work function of 9ρ . Estimate the threshold frequency for this metal.

1 mark

 Hz

d. Estimate the value of Planck's constant in ρ s.

2 marks

Question 15

Describe the limitation of the wave model of light in explaining experimental *results* related to the photoelectric effect. Give two *results* in your answer with explanation.

4 marks

Question 16

Electrons (each of mass 9.1×10^{-31} kg and charge -1.6×10^{-19} C) are accelerated across a potential difference of 200 V.

a. Calculate the resulting de Broglie wavelength of the electrons. Show your working.

2 marks

b. Name and explain an experimental result which can be used as evidence for the wave-like nature of matter.

2 marks

Question 17

The following diagram shows the four lowest energy levels for hydrogen, from $n = 4$ to $n = 1$.

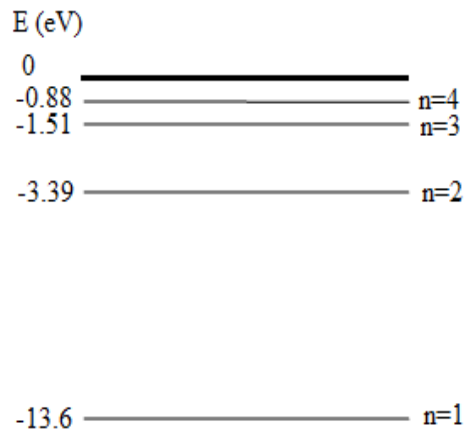

a. The visible part of the electromagnetic spectrum has wavelengths in the interval 400 nm to 750 nm approximately.

Determine one wavelength in the visible spectrum which can be absorbed by hydrogen gas.

2 marks

b. How many different photons (photons of different energy) can be emitted when an excited hydrogen atom at the third excited state returns to the ground state?

2 marks

c. Calculate the momentum of the photon resulting in the emission of yellow light (587.5 nm).

2 marks

Question 18

a. Describe how to carry out a single-photon Young's double-slit experiment.

2 marks

b. What conclusion can be drawn from this experiment?

1 mark

c. Use the conclusion to explain the quantised states of the atom.

2 marks

End of examination