

**Victorian Certificate of Education**  
**Year**

SUPERVISOR TO ATTACH PROCESSING LABEL HERE

STUDENT NUMBER

--	--	--	--	--	--	--	--	--	--	--	--	--	--

Letter

**PHYSICS**  
**Written examination**

**Day Date**

**Reading time: \*.\*.\* to \*.\*.\* (15 minutes)**

**Writing time: \*.\*.\* to \*.\*.\* (2 hours 30 minutes)**

**QUESTION AND ANSWER BOOK**

**Structure of book**

<i>Section</i>	<i>Number of questions</i>	<i>Number of questions to be answered</i>	<i>Number of marks</i>
A	20	20	20
B	18	18	110
			Total 130

- Students are permitted to bring into the examination room: pens, pencils, highlighters, erasers, sharpeners, rulers, pre-written notes (one folded A3 sheet or two A4 sheets bound together by tape) and one scientific calculator.
- Students are NOT permitted to bring into the examination room: blank sheets of paper and/or correction fluid/tape.

**Materials supplied**

- Question and answer book of 43 pages
- Formula sheet
- Answer sheet for multiple-choice questions

**Instructions**

- Write your student number in the space provided above on this page.
- Check that your **name** and **student number** as printed on your answer sheet for multiple-choice questions are correct, **and** sign your name in the space provided to verify this.
- Unless otherwise indicated, the diagrams in this book are **not** drawn to scale.
- All written responses must be in English.

**At the end of the examination**

- Place the answer sheet for multiple-choice questions inside the front cover of this book.
- You may keep the formula sheet.

**Students are NOT permitted to bring mobile phones and/or any other unauthorised electronic devices into the examination room.**

**SECTION A – Multiple-choice questions****Instructions for Section A**

Answer **all** questions in pencil on the answer sheet provided for multiple-choice questions.

Choose the response that is **correct** or that **best answers** the question.

A correct answer scores 1; an incorrect answer scores 0.

Marks will **not** be deducted for incorrect answers.

No marks will be given if more than one answer is completed for any question.

Unless otherwise indicated, the diagrams in this book are **not** drawn to scale.

Take the value of  $g$  to be  $9.8 \text{ m s}^{-2}$ .

**Question 1**

Which one of the following diagrams shows the electric field pattern surrounding two equal, positive point charges?

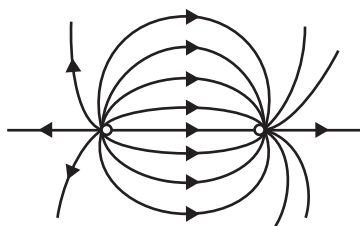
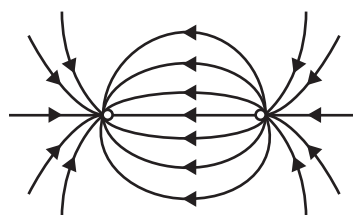
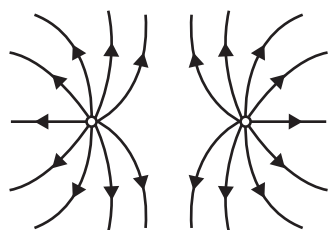
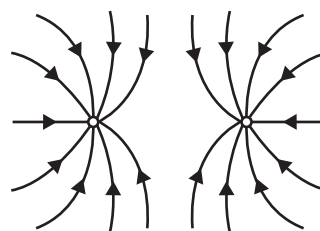
**A.****B.****C.****D.**

**Question 2**

The three diagrams X, Y and Z below represent different types of fields.

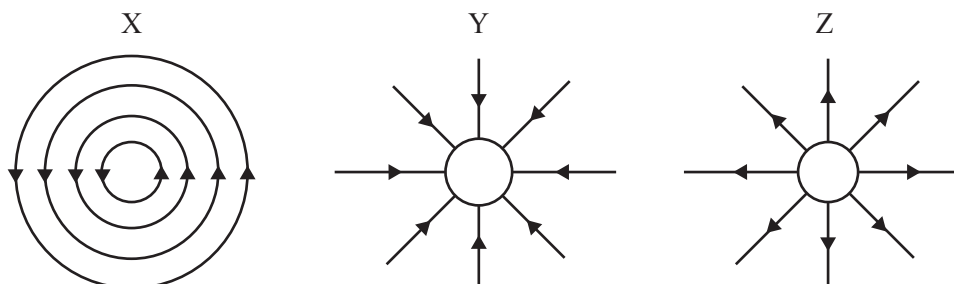

Which one of the following statements about these diagrams is correct?

- A. X could be an electric field, Y could be a gravitational field and Z could be a magnetic field.
- B. X could be a gravitational field, Y could be an electric field and Z could be a magnetic field.
- C. X could be a magnetic field, Y could be a gravitational field and Z could be an electric field.
- D. X could be a gravitational field, Y could be a magnetic field and Z could be an electric field.

**Question 3**

Students measure the gravitational force between two masses of 1.0 kg and 100 kg, placed 10 cm apart.

The universal gravitational constant,  $G$ , is  $6.67 \times 10^{-11} \text{ N m}^2 \text{ kg}^{-2}$ .

Which one of the following best gives the gravitational force of attraction between the two masses?

- A.  $1.0 \times 10^{-3} \text{ N}$
- B.  $6.7 \times 10^{-5} \text{ N}$
- C.  $6.7 \times 10^{-7} \text{ N}$
- D.  $1.0 \times 10^6 \text{ N}$

**Question 4**

The diagram below shows a solenoid.

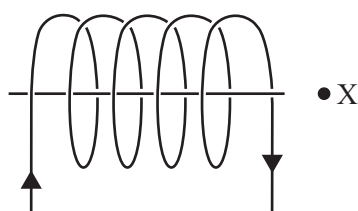

Which one of the following best describes the direction of the magnetic field of the coil at point X?

- A. left
- B. right
- C. up
- D. out of the page

**Question 5**

A metal sphere has a charge of  $1.0 \times 10^{-8}$  C on it.

A small sphere with a charge of  $1.0 \times 10^{-9}$  C is placed 30 cm from it.

Assume both can be considered point charges.

Take  $k = 9.0 \times 10^9$ .

Which one of the following best gives the magnitude of the force on the small sphere?

- A.  $1.1 \times 10^{-14}$  N
- B.  $1.0 \times 10^{-6}$  N
- C.  $3.0 \times 10^{-6}$  N
- D.  $3.0 \times 10^{-5}$  N

**Question 6**

In an experimental investigation, an independent variable is one that

- A. the investigator selects values for.
- B. is the key variable to be measured.
- C. is fixed throughout the experiment.
- D. is independent of the investigator's control.

**Question 7**

In an experimental investigation, a dependent variable is one that

- A. the investigator selects values for.
- B. can be fixed throughout the experiment.
- C. is the least important variable to be measured.
- D. depends on the selected values of another variable.

**Question 8**

In an experimental investigation, generally, a controlled variable is one that

- A. is fixed throughout a particular section of the experiment.
- B. is dependent on the selected values of another variable.
- C. is the least important variable to be measured.
- D. the investigator controls the values for.

**Question 9**

Some students are measuring the acceleration due to gravity in a region of Earth's surface where the value is well established as  $9.81 \pm 0.01 \text{ m s}^{-2}$ . They take five measurements, as follows:

- $9.83 \text{ m s}^{-2}$
- $9.81 \text{ m s}^{-2}$
- $9.79 \text{ m s}^{-2}$
- $9.78 \text{ m s}^{-2}$
- $9.84 \text{ m s}^{-2}$

Systematic errors are negligible.

The students could reasonably describe the measurement uncertainty of their results as about

- A.  $0.03 \text{ m s}^{-2}$
- B.  $0.10 \text{ m s}^{-2}$
- C.  $0.005 \text{ m s}^{-2}$
- D.  $9.81 \text{ m s}^{-2}$

**Question 10**

An electron travelling in the  $y$ -direction at a known velocity passes through a narrow slit in a barrier, as shown below.

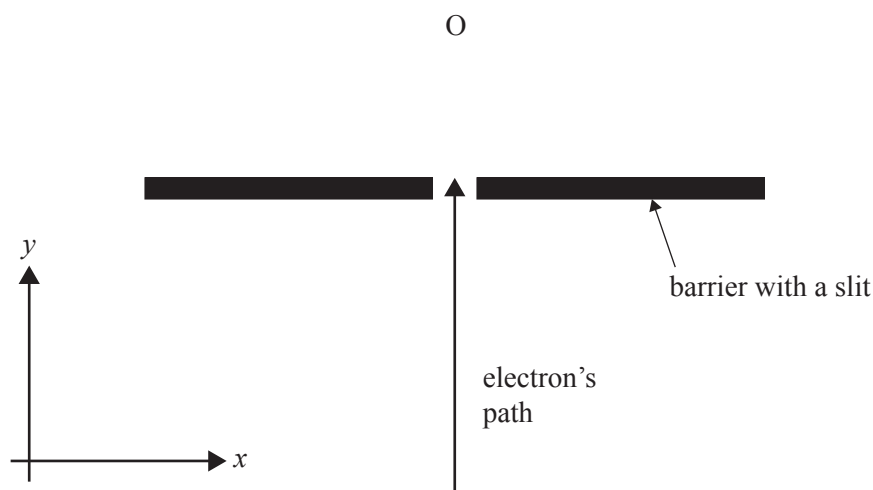

Which one of the following statements best describes how Heisenberg's uncertainty principle applies to an electron's motion after it passes through the slit?

- A. The electron must pass through point O.
- B. The electron can never pass through point O.
- C. There is an uncertainty in its momentum in the  $y$ -direction.
- D. There is an uncertainty in its momentum in the  $x$ -direction after passing through the slit, depending on the width of the slit.

**Question 11**

A test car is equipped with a crash-test dummy and an airbag. The car comes to a sudden stop when it collides with a solid wall, causing the airbag to inflate. The airbag then compresses by 0.10 m when the crash-test dummy hits the airbag. The diagram below shows the relative position of the crash-test dummy's head to the airbag and steering wheel.

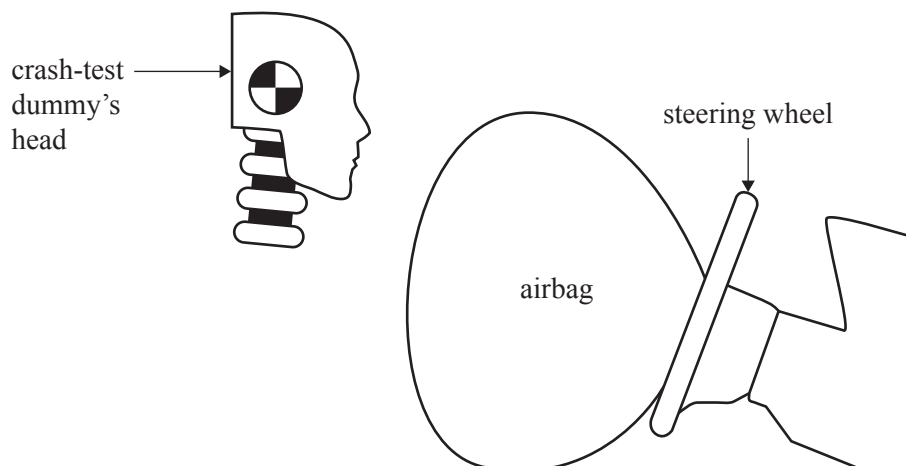

The graph of retarding force on the crash-test dummy's head versus compression distance is shown below.

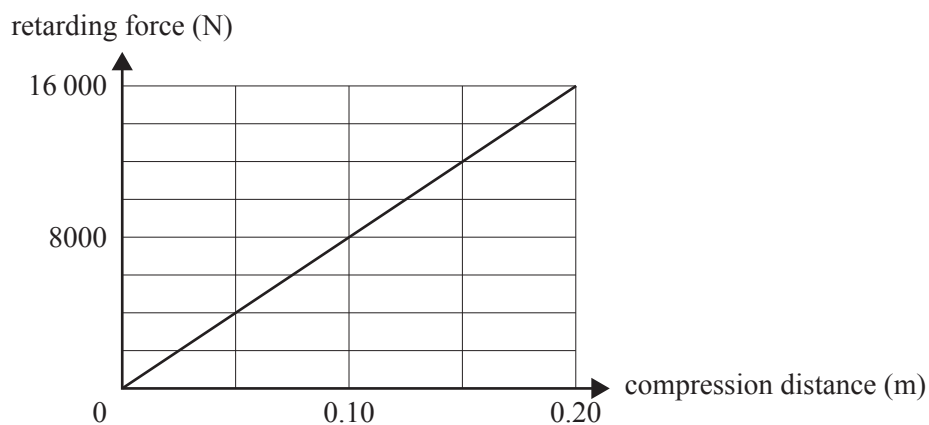

Which one of the following best gives the work done on the airbag in this collision?

- A. 80 J
- B. 400 J
- C. 800 J
- D. 8000 J

**Question 12**

Which one of the following best describes the proper length of an object travelling with constant velocity?

- A. the length when measured with a proper standard measuring stick
- B. the length when measured by an observer at rest relative to the object
- C. the length when both ends of the object are measured at the same time
- D. the length when measured by an observer in an inertial frame of reference

**Question 13**

Which of the following correctly relates the direction of oscillation of the particles in a medium to the direction of energy propagation for a transverse wave and a longitudinal wave?

	<b>Transverse wave</b>	<b>Longitudinal wave</b>
A.	at right angles	parallel
B.	at right angles	at right angles
C.	parallel	parallel
D.	parallel	at right angles

**Question 14**

An ambulance is sounding its siren as it approaches a pedestrian.

Which one of the following best describes the sound waves reaching the pedestrian when the ambulance is moving towards the pedestrian?

- A. The speed of the sound waves in air is higher.
- B. The distance between successive wave crests reaching the pedestrian is larger.
- C. The distance between successive wave crests reaching the pedestrian is the same.
- D. The distance between successive wave crests approaching the pedestrian is smaller.

DO NOT WRITE IN THIS AREA

Use the following information to answer Questions 15 and 16.

Kim plucks one of his guitar strings, causing it to vibrate as shown below. Two extreme positions of the resulting standing wave in the string are shown. For the purpose of the following questions, the amplitude of the vibrations has been exaggerated.

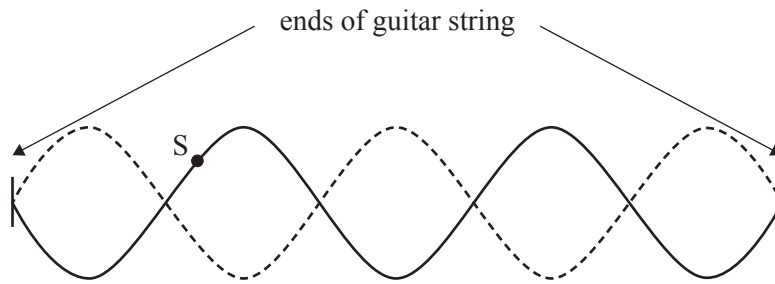

### Question 15

Which one of the following statements best indicates how we interpret the motion of the guitar string shown above?

- A. It is the result of two transverse waves travelling along the string in the same direction.
- B. It is the result of two transverse waves travelling along the string in opposite directions.
- C. It is the result of two longitudinal waves travelling along the string in the same direction.
- D. It is the result of two longitudinal waves travelling along the string in opposite directions.

### Question 16

S is a point on the guitar string, as shown above.

For the instant **immediately after** that shown above, the direction in which point S on the guitar string will move is

- A. upwards.
- B. to the left.
- C. to the right.
- D. downwards.

### Question 17

Light can be polarised because it is

- A. a circular wave.
- B. a transverse wave.
- C. a longitudinal wave.
- D. an electromagnetic wave and has both transverse and longitudinal components.



**Question 18**

Which one of the following statements best describes light produced from a range of sources?

- A. Light from an incandescent lamp is generally coherent and contains a wide spectrum of wavelengths.
- B. Light from a single-colour light-emitting diode (LED) is coherent and contains a very wide spectrum of wavelengths.
- C. Synchrotron light is always incoherent and contains a wide spectrum of wavelengths.
- D. Light from a laser is coherent and has a very narrow range of wavelengths.

**Question 19**

What is the best description of how light is produced in an LED?

- A. thermal motion of electrons in the valence band
- B. transition of electrons from the conduction band to the ground state
- C. transition of electrons from the conduction band to the valence band
- D. transition of electrons from the valence band to the conduction band

**Question 20**

An absorption line in a spectrum occurs at 414 nm.

**Data**

Planck's constant	$h = 4.14 \times 10^{-15} \text{ eV s}$
speed of light in a vacuum	$c = 3.0 \times 10^8 \text{ m s}^{-1}$

Which one of the following best gives the energy of the photon for this absorption?

- A.  $4.8 \times 10^{-19} \text{ eV}$
- B. 0.33 eV
- C. 3.0 eV
- D. 4.1 eV

DO NOT WRITE IN THIS AREA

END OF SECTION A  
TURN OVER

**SECTION B****Instructions for Section B**

Answer **all** questions in the spaces provided. Write using blue or black pen.

Where an answer box is provided, write your final answer in the box.

If an answer box has a unit printed in it, give your answer in that unit.

In questions where more than one mark is available, appropriate working **must** be shown.

Unless otherwise indicated, the diagrams in this book are **not** drawn to scale.

Take the value of  $g$  to be  $9.8 \text{ m s}^{-2}$ .

**Question 1** (5 marks)

The mass of the planet Mars is  $6.4 \times 10^{23} \text{ kg}$ .

The radius of Mars is  $3.4 \times 10^6 \text{ m}$ .

The universal gravitational constant,  $G$ , is  $6.67 \times 10^{-11} \text{ N m}^2 \text{ kg}^{-2}$ .

- a. Calculate the acceleration due to gravity at the surface of Mars. Show your working.

2 marks

---

---

---

$\text{m s}^{-2}$

DO NOT WRITE IN THIS AREA

- b. A probe of mass 0.20 kg is released from a height of 10 m above the surface of Mars. Assume that the gravitational field strength is uniform (the same as at the surface). Ignore air resistance.

Sketch the gravitational potential energy of the probe as a function of height above the surface of Mars on the axes provided below and label this as  $U_g$ . Take potential energy at the surface of Mars as zero. Include the initial potential energy value on the energy axis.

On the same axes, sketch the kinetic energy of the probe and label this as  $E_K$ .

3 marks

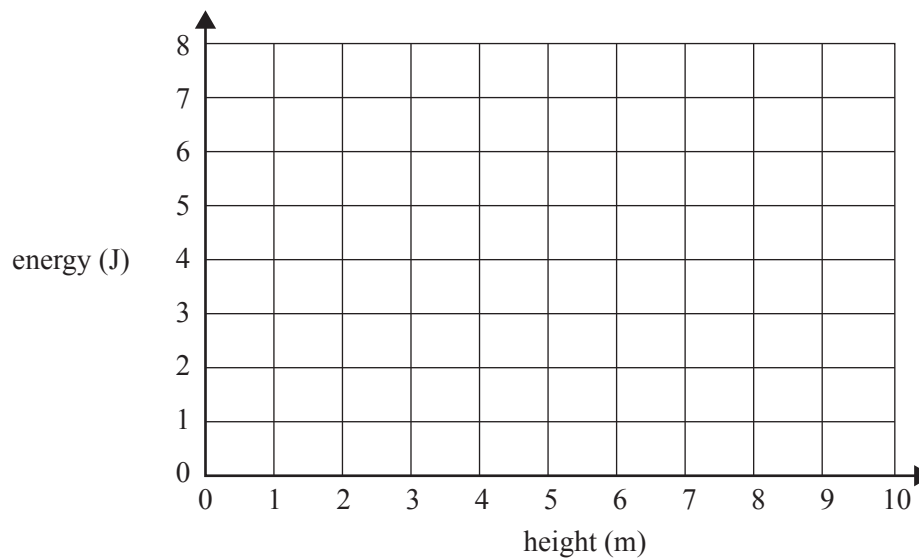

DO NOT WRITE IN THIS AREA

**Question 2** (8 marks)

Figure 1 shows part of a particle accelerator. Electrons are accelerated by a voltage of 10 000 V in an electron gun consisting of two plates that are 0.10 m apart. After exiting the gun, the electrons pass into a region of uniform magnetic field of strength 0.020 tesla directed into the page. Ignore relativistic effects.

**Data**

mass of the electron	$9.1 \times 10^{-31} \text{ kg}$
charge on the electron	$-1.6 \times 10^{-19} \text{ C}$
strength of the magnetic field	0.020 tesla

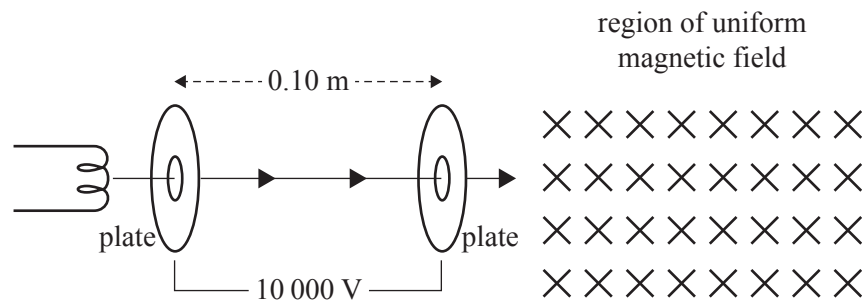

**Figure 1**

- a. Calculate the strength of the electric field between the plates. Include an appropriate unit. 2 marks

---



---



---

- b. Calculate the speed of the electrons as they exit the electron gun. 2 marks

---



---



---

$\text{m s}^{-1}$

DO NOT WRITE IN THIS AREA

- c. The electrons next enter the region of uniform magnetic field.

Calculate the radius of the path of the electrons.

2 marks

---



---



---

m

- d. In another part of the particle accelerator, the electrons are deflected by a uniform electric field, as shown in Figure 2a, and by a magnetic field, as shown in Figure 2b.

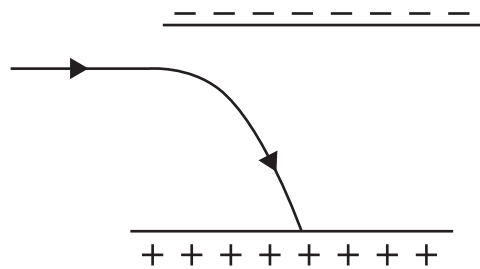

Figure 2a

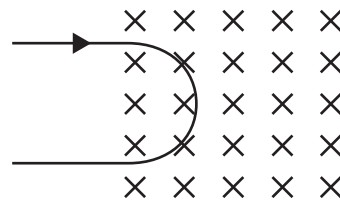

Figure 2b

Explain why the paths of the electrons in the two fields have different shapes.

2 marks

---



---



---



---



---



---

DO NOT WRITE IN THIS AREA

**Question 3** (5 marks)

Figure 3 shows a DC motor consisting of a square loop of 100 turns and side length 5 cm, and a commutator. The DC motor has a uniform magnetic field of  $3.0 \times 10^{-2} \text{ T}$  and a current of 2.0 A.

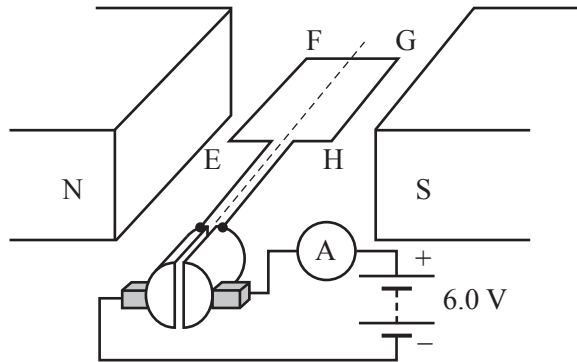

**Figure 3**

- a. What is the force on the side EH when the loop is in the position shown in Figure 3? Explain your answer.

2 marks

---



---



---



- b. Explain the role and operation of the commutator in the DC motor shown in Figure 3.

3 marks

---



---



---



---



---

DO NOT WRITE IN THIS AREA

**DO NOT WRITE IN THIS AREA**

**CONTINUES OVER PAGE**

**SECTION B – continued  
TURN OVER**

**Question 4 (6 marks)**

Figure 4 shows a simple AC alternator.

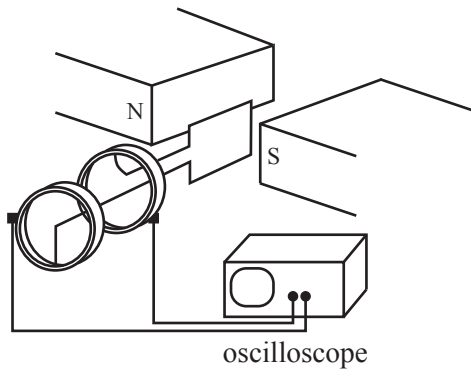

**Figure 4**

The strength of the magnetic field is 0.50 T, the loop has 20 turns, the area of the loop is 0.020 m<sup>2</sup> and the rate of rotation is 10 Hz.

- a. Calculate the magnitude of the average EMF induced as the loop turns from the instant shown in Figure 4 to a point one-quarter of a period later. Show your working and include an appropriate unit. 3 marks

---



---



---

- b. The AC alternator gradually slows to a stop.  
On the grid provided below, sketch the voltage output expected. Scale values are not required on the axes. 3 marks

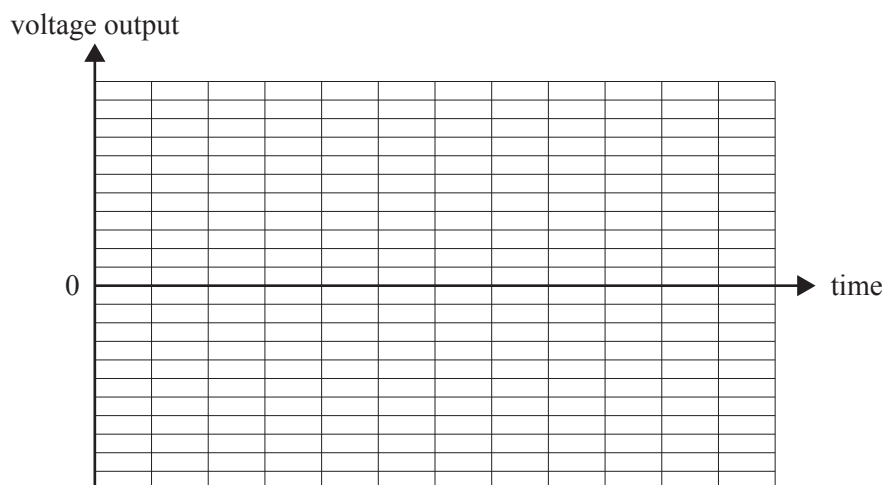



**Question 5** (3 marks)

An oscilloscope is connected to a sinusoidal AC source whose frequency and voltage output can be varied. Figure 5 shows the trace obtained on the oscilloscope screen, where one horizontal division represents a time of 20 ms and one vertical division represents 10 V.

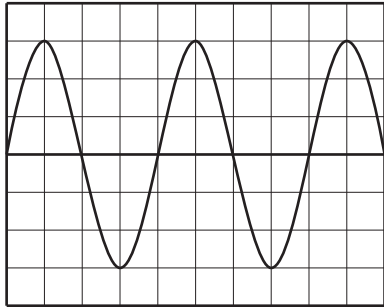
**Figure 5**

- a. Calculate the RMS voltage for the signal shown in Figure 5.

2 marks

---



---



---

V
---

- b. Calculate the frequency for the signal shown in Figure 5.

1 mark

---



---



---

Hz
----

DO NOT WRITE IN THIS AREA

**Question 6** (5 marks)

Juan conducts an experiment using a shallow tray of water in which waves can be observed. He first produces straight waves at a frequency of 5 Hz. He measures the wavelength and finds it to be 10 cm.

- a. Calculate the speed of the waves. 1 mark

---



---



---

$\text{cm s}^{-1}$

- b. Juan now uses two point sources producing waves at the same wavelength (10 cm) to investigate two point source interference patterns, as shown in Figure 6.

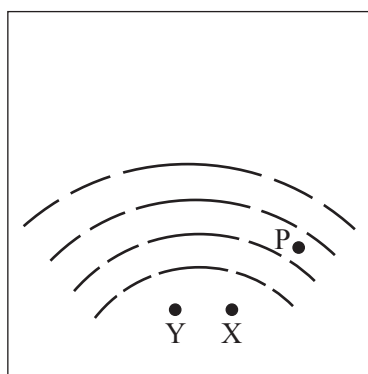

**Figure 6**

He observes lines of maxima and minima in the resultant pattern, as shown in Figure 6. The lines on the diagram represent wave crests.

Point P is on a line of minima (nodal line).

Juan measures the distance from source X to point P as 16.0 cm.

- Determine the distance from source Y to point P. 2 marks

---



---

$\text{cm}$

DO NOT WRITE IN THIS AREA

- c. Juan now produces straight waves and places a narrow gap in front of the waves, as shown in Figure 7. He next measures the width of the diffraction pattern.

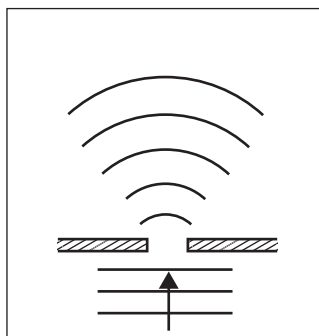

Figure 7

Juan increases the frequency of the source.

Explain the effect that this would have on the diffraction pattern shown in Figure 7.

2 marks

---

---

---

---

---

---

---

DO NOT WRITE IN THIS AREA

**Question 7** (4 marks)

Rani is conducting experiments to study the refraction of light.

- a. Rani passes a beam of light from a laser from air into a glass slab, as shown in Figure 8.

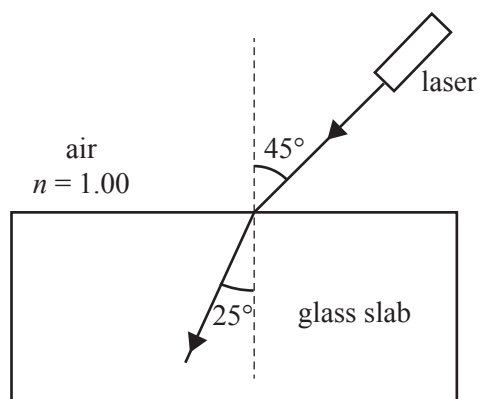

**Figure 8**

Calculate the refractive index of the glass.

1 mark

---

---

DO NOT WRITE IN THIS AREA

Rani next shines a ray of light from underwater to a water–air interface, as shown in Figure 9.

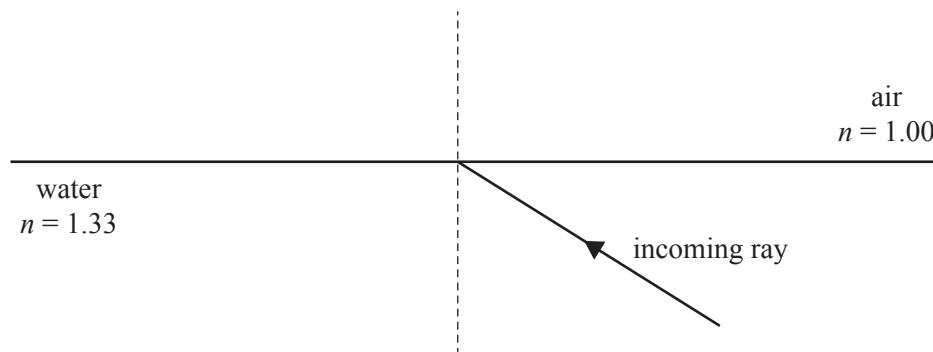

**Figure 9**

- b. Determine the critical angle for the total internal reflection at the water–air interface. 1 mark

---



---

- c. The angle of incidence is increased to an angle slightly greater than the critical angle,  $i_c$ .  
On the diagram provided below, draw in any ray or rays that Rani would observe. 2 marks

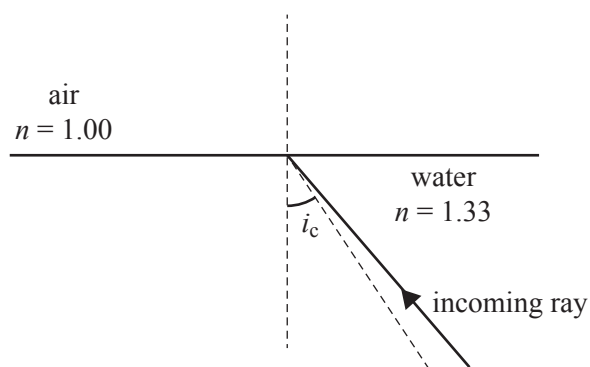

**Question 8** (2 marks)

List the following bands of the electromagnetic spectrum in order from longest wavelength to shortest wavelength by writing each corresponding number in the appropriate box below:

1. infra-red radiation
2. microwaves
3. radio waves
4. ultraviolet radiation
5. visible light
6. X-rays

**Longest****Shortest**

--	--	--	--	--	--

**DO NOT WRITE IN THIS AREA**

**Question 9** (2 marks)

Figure 10 shows the energy-level diagram for the hydrogen atom.

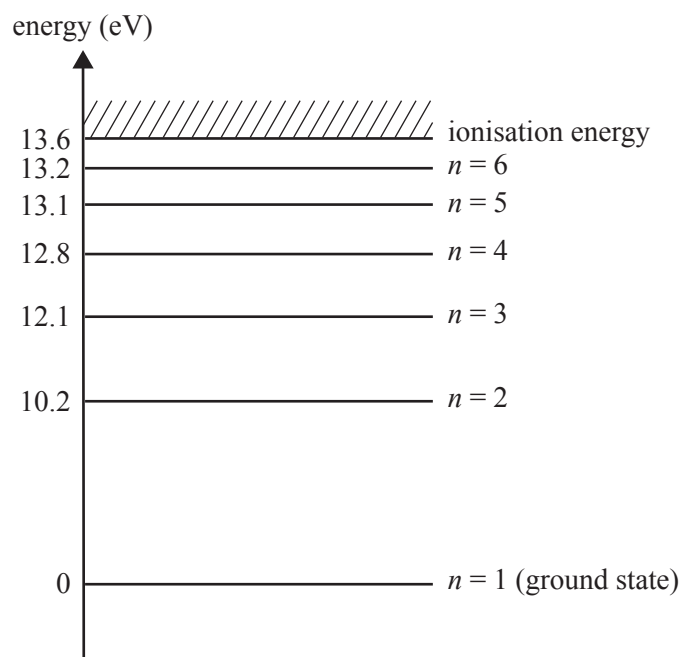

**Figure 10**

An atom of hydrogen is excited to the  $n = 4$  state.

List the possible energies, in eV, of photons that could be emitted as this atom returns to the ground state.

---

---

---

---

---

---

---

DO NOT WRITE IN THIS AREA

**Question 10** (9 marks)

A rural town is supplied with electricity from a small hydro-electric power plant about 20 km from the town. The alternator generates electricity at 5000 V. This is stepped up in a transformer to 50 000 V.

Electricity is transmitted to the town through a two-wire high-voltage transmission line. The input voltage to the transmission line at the alternator end is  $50\,000\text{ V}_{\text{RMS AC}}$ . The current in the line is  $15\text{ A}_{\text{RMS}}$ . At the edge of the town, a transformer converts the voltage to  $250\text{ V}_{\text{RMS AC}}$  for use in the town. The total resistance of the transmission line is  $40\ \Omega$ . The system is shown in Figure 11. Assume that the transformers are ideal.

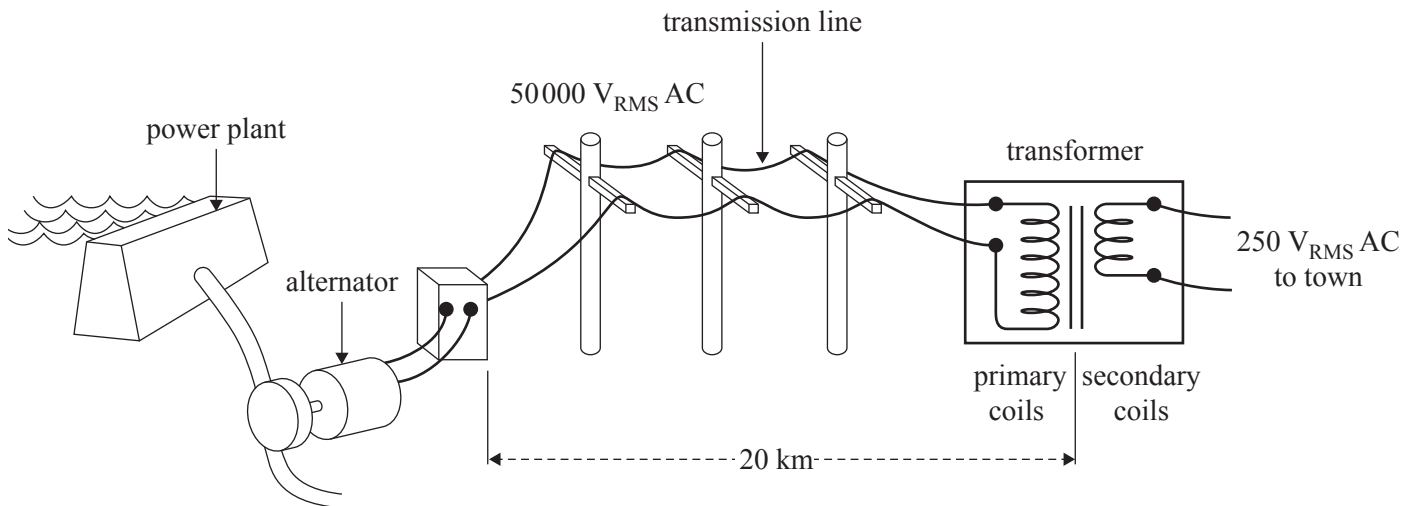

**Figure 11**

- a. Calculate the total power loss in the transmission line. Show your working. 3 marks

---



---



---



---



---



---

W

**DO NOT WRITE IN THIS AREA**



DO NOT WRITE IN THIS AREA

- b. Calculate the voltage input from the transmission line to the step-down transformer at the town end of the line.

3 marks

---

---

---

---

---

---

---

---

V
---

- c. Explain why AC rather than DC is generally used for long-distance power transmission. Include the steps involved in the process of long-distance power transmission.

3 marks

---

---

---

---

---

---

---

---

---

---

---

---

---

---

---

---

---

---

---

---

---

---

---

---

**Question 11** (6 marks)

Some students conduct an experiment using two trolleys, A and B, of mass 6.0 kg and 2.0 kg respectively. In the experiment, Trolley A is moving at  $2.0 \text{ m s}^{-1}$  and Trolley B is stationary before they collide. There is a spring between the two trolleys, attached to Trolley B.

When the trolleys collide, they compress the spring and then move apart again. After the collision, Trolley A is moving at  $1.0 \text{ m s}^{-1}$ . The experimental set-up is shown in Figure 12. Ignore the mass of the spring.



**Figure 12**

- a. Calculate the speed of Trolley B immediately after the collision. 2 marks

---



---



---



---

$\text{m s}^{-1}$

- b. Determine whether the collision is elastic or inelastic. Show your working. 2 marks

---



---



---



---



---

**DO NOT WRITE IN THIS AREA**

- c. A pair of students, Pat and Alex, discuss how the kinetic energy of the system would vary with time. Pat's opinion is that the variation would be represented by the graph in Figure 13a.

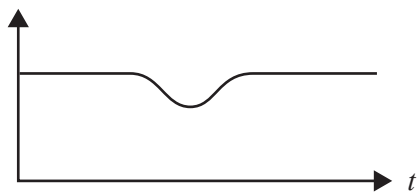

Figure 13a

Alex's opinion is that the variation would be represented by the graph in Figure 13b.

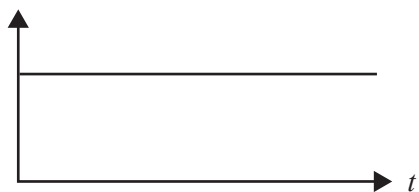

Figure 13b

Who is correct? Explain your answer.

2 marks

---

---

---

---

DO NOT WRITE IN THIS AREA

**Question 12** (4 marks)

Figure 14a shows a model car of mass 5.00 kg moving in a part of a vertical circle of radius 4.00 m. At the lowest point, L, the car is moving at  $5.00 \text{ m s}^{-1}$ . Figure 14b shows the model car at the lowest point, L.

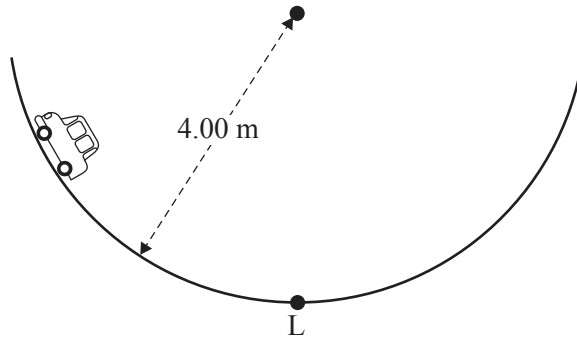

**Figure 14a**

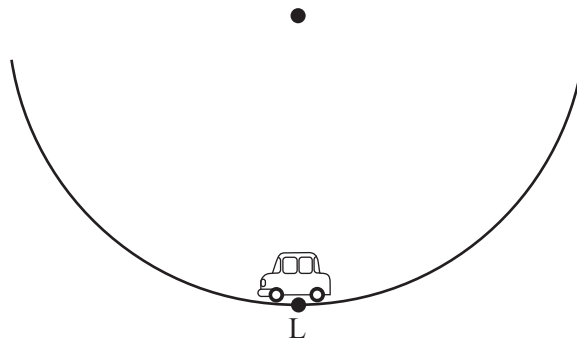

**Figure 14b**

- a. On Figure 14b, draw an arrow to show the resultant force on the car at point L. 1 mark
- b. Calculate the normal reaction force of the track on the car at point L. Show your working. 3 marks

---



---



---



---

N
---

**DO NOT WRITE IN THIS AREA**

**Question 13** (3 marks)

A stone of mass  $2.0 \text{ kg}$  is thrown from the top of a  $15 \text{ m}$  high cliff above the sea at an angle of  $30^\circ$  to the horizontal and at an initial speed of  $20 \text{ m s}^{-1}$ , as shown in Figure 15. Ignore air resistance.

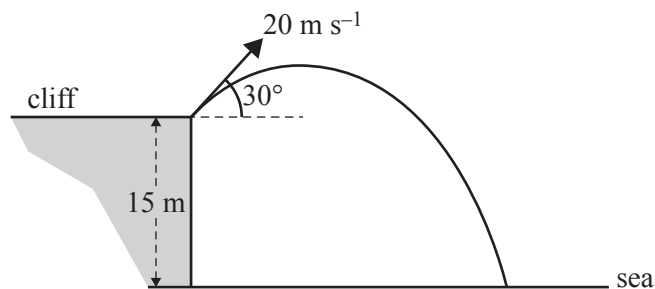
**Figure 15**

Calculate the kinetic energy of the stone immediately before it strikes the sea. Show your working.

---

---

---

---

--

 J

DO NOT WRITE IN THIS AREA

**Question 14** (10 marks)

Some students test a spring to determine the spring constant,  $k$ . The experimental set-up is shown in Figure 16.

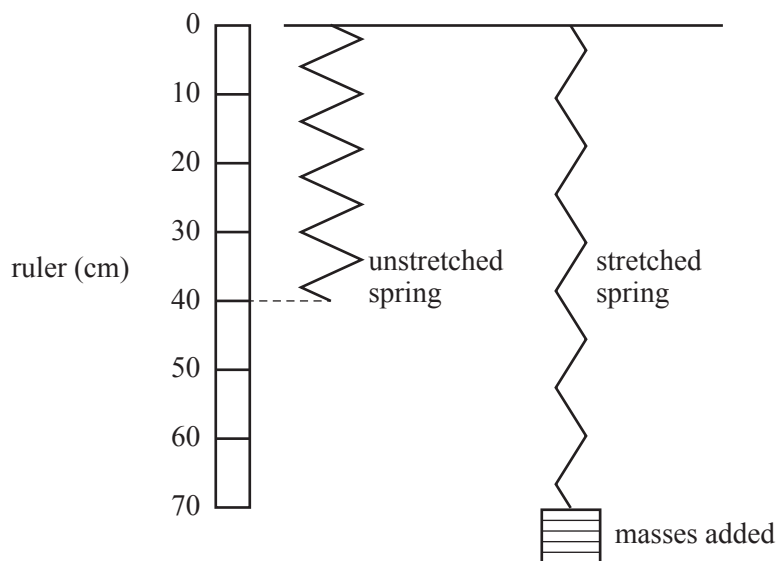

**Figure 16**

Five 0.50 kg masses are successively added to the end of the spring and the resulting length of the spring was measured each time. The results are shown in the table below.

Number of 0.50 kg masses	Length of spring
0	40 cm
1	45 cm
2	53 cm
3	57 cm
4	63 cm
5	70 cm

- a. Record the data from the table as a graph on the grid below. Include labels, scales and units on each axis. Given that these measurements were taken with a metre ruler, graduated to 5 cm intervals and held by hand, insert realistic uncertainty bars (or error bars). Draw a line of best fit.

5 marks



- b. From the graph in **part a.**, determine the spring constant,  $k$ , of the spring and include a possible uncertainty in your value.

3 marks

---

---

---

$\text{N m}^{-1}$
-------------------

- c. All five masses are added to the end of the spring. The spring is then raised to the 40 cm position and released.

Calculate how far the spring stretches below its initial rest position. Show your working.

2 marks

---

---

---

---

---

---

---

cm
----

DO NOT WRITE IN THIS AREA



**DO NOT WRITE IN THIS AREA**

**CONTINUES OVER PAGE**

**SECTION B – continued  
TURN OVER**

**Question 15** (6 marks)

Muons are elementary particles created in the upper atmosphere by cosmic rays. They are unstable and decay with a half-life of  $2.2 \mu\text{s}$  ( $2.2 \times 10^{-6} \text{ s}$ ) when measured at rest. This means that in the reference frame of the muons, half of them decay in each time interval of  $2.2 \mu\text{s}$ .

In an experiment, muons with a velocity of  $0.995c$  ( $\gamma = 10$ ) were observed by some scientists to pass the top of a mountain of height  $2627 \text{ m}$ , as shown in Figure 17. The scientists measured the number of these muons reaching ground level.

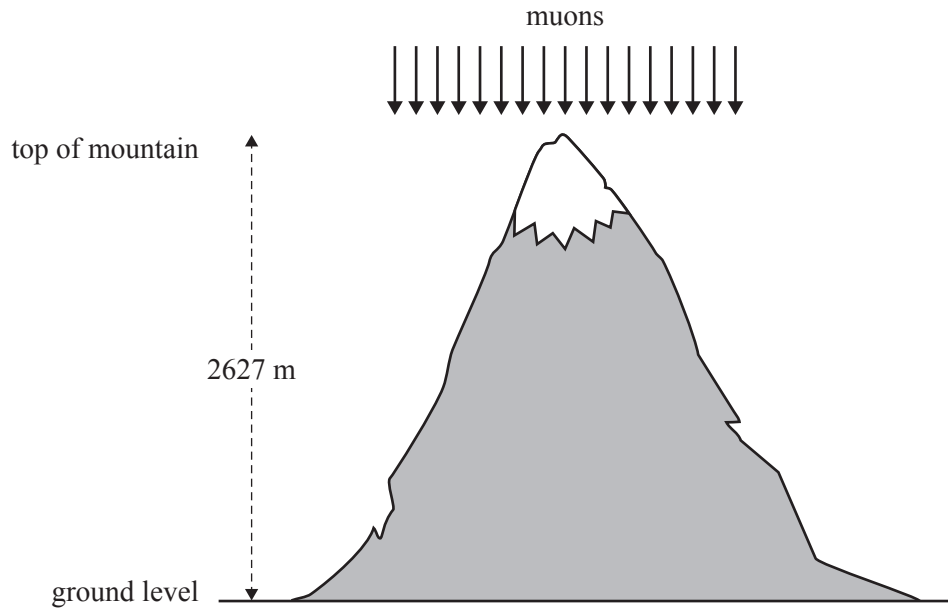

**Figure 17**

- a. Calculate the half-life of the muons as measured by a stationary observer on the ground in Figure 17. 2 marks

---



---



---



---

s
---

**DO NOT WRITE IN THIS AREA**

b. From their reference frame, the muons see the ground rushing upwards at a speed of  $0.995c$ .

Find the height of the mountain as measured by the muons.

2 marks

---

---

---

---

m
---

c. Explain why many more muons reached the ground than would be expected according to classical physics.

2 marks

---

---

---

---

---

---

---

---

---

---

DO NOT WRITE IN THIS AREA

**Question 16 (7 marks)**

Some students study the diffraction of electrons by a crystal lattice.

The apparatus is shown in Figure 18a. In this apparatus, electrons of mass  $9.1 \times 10^{-31}$  kg are accelerated to a speed of  $1.50 \times 10^7$  m s<sup>-1</sup>.

The electrons pass through the crystal and the diffraction pattern is observed on a fluorescent screen. The pattern that the students observe is shown in Figure 18b.

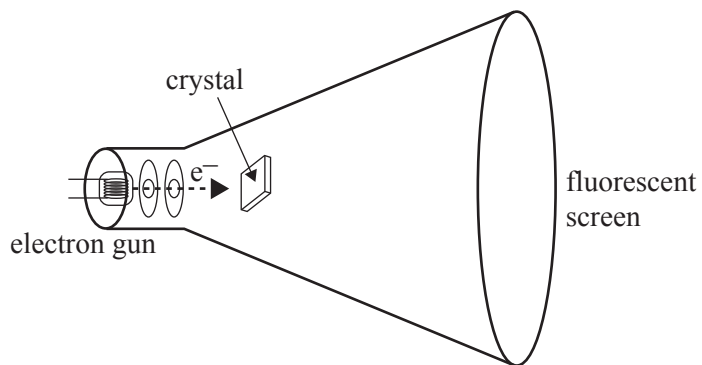

**Figure 18a**

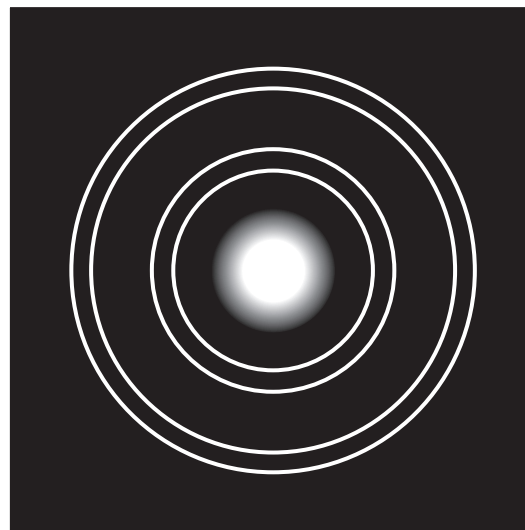

**Figure 18b**

- a. Calculate the de Broglie wavelength of the electrons. Show your working. 2 marks

---



---



---

nm
----

- b. The students next increase the accelerating voltage and hence the speed of the electrons. Describe the change to the pattern that they will observe and give your reasoning. 2 marks

---



---



---



---

**DO NOT WRITE IN THIS AREA**

- c. The students replace the electron source with an X-ray source and find that the pattern on the screen is similarly shaped and spaced to the pattern observed when the electrons were at the original speed of  $1.50 \times 10^7 \text{ m s}^{-1}$ .

Calculate the energy of a photon from this X-ray source. Give your answer correct to three significant figures.

3 marks

---

---

---

---

eV
----

DO NOT WRITE IN THIS AREA

**Question 17** (14 marks)

Some students set up the apparatus shown in Figure 19 to study the photoelectric effect; in particular, the relationship between the frequency and intensity of incoming light and the maximum kinetic energy of emitted photoelectrons. Assume that all filters give light of the same intensity.

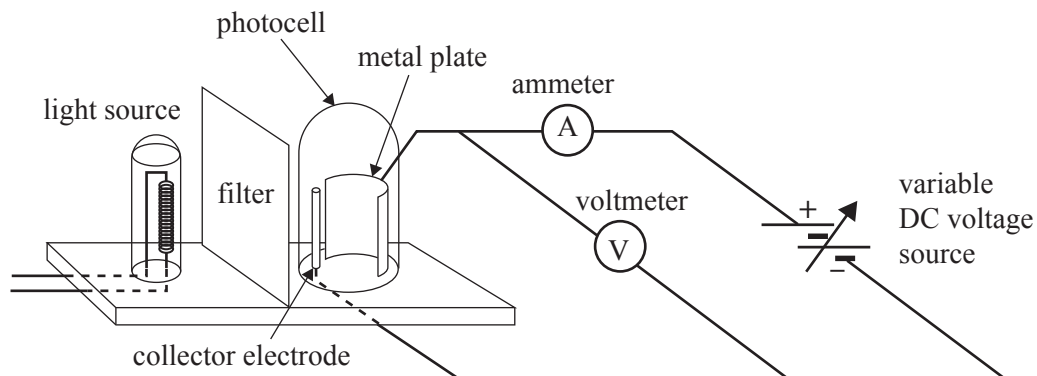
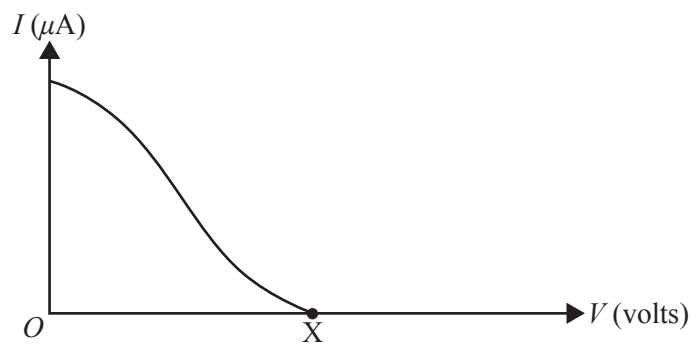

**Figure 19**

The apparatus consists of:

- a source of white light
- a set of filters, each of which allows only light of a selected wavelength to pass through
- a photocell consisting of a metal plate and a collector electrode enclosed in an evacuated (no air) glass case
- a voltmeter (V), an ammeter (A) and a variable DC voltage source in a circuit, as shown above.

- a. With a particular filter in place and the same light source, the students gradually increase the voltage, as measured by the voltmeter, from zero. They plot the current measured by the ammeter as a function of the voltage measured by the voltmeter. This is shown in Figure 20.



**Figure 20**

Explain why the current drops to zero at point X.

2 marks

---

---

---

---

---

---

---

DO NOT WRITE IN THIS AREA

The students next use five filters to give five frequencies of light falling on the metal plate and measure the stopping voltage on the voltmeter for each frequency. The data collected is shown in the table below.

Frequency (Hz)	Stopping voltage ( $V_s$ )
$4.5 \times 10^{14}$	1.3
$5.0 \times 10^{14}$	1.5
$6.1 \times 10^{14}$	2.0
$6.9 \times 10^{14}$	2.5
$7.6 \times 10^{14}$	2.8

- b. Plot the data given in the table above on the axes provided below, then draw a line of best fit to show maximum kinetic energy of the emitted photoelectrons versus frequency of light falling on the metal plate.

3 marks

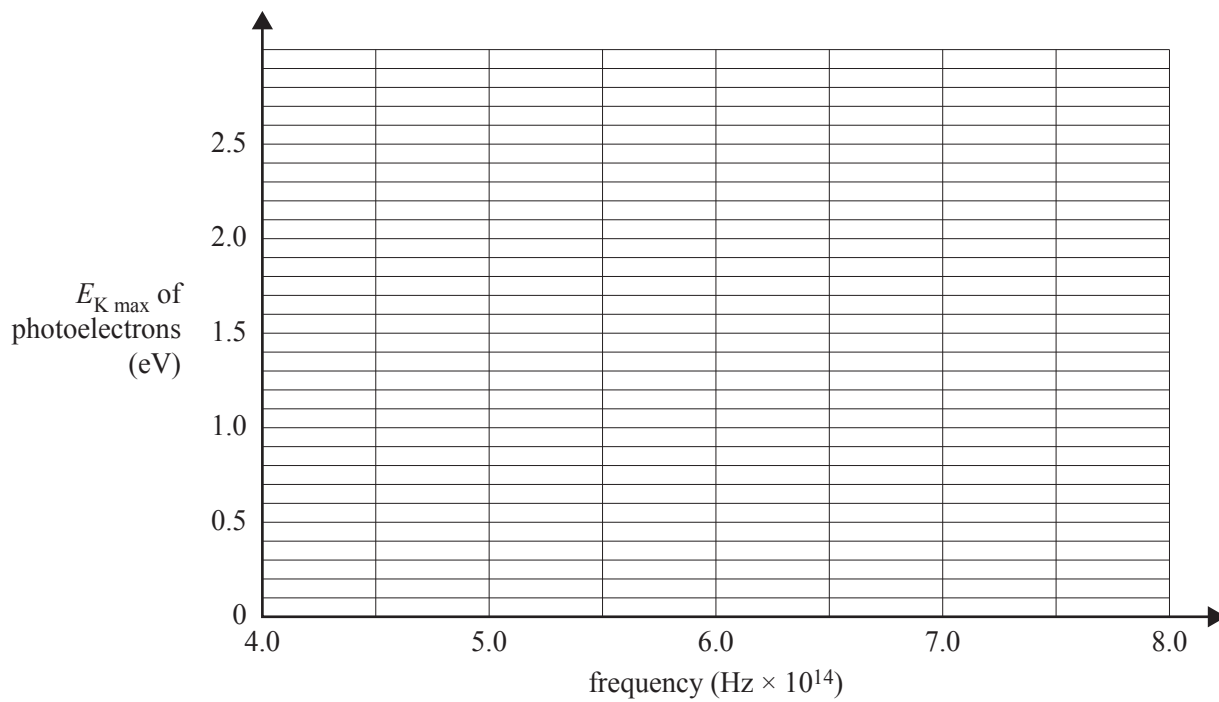

- c. From the graph plotted in **part b.**, determine the value of Planck’s constant,  $h$ , that the students would have obtained. Give your answer correct to two significant figures.

2 marks

---



---

eV s

DO NOT WRITE IN THIS AREA



- d. For this particular experiment, identify each of the following. 2 marks

Dependent variable(s) \_\_\_\_\_

Independent variable(s) \_\_\_\_\_

- e. For this particular experiment, identify **one** important controlled variable and indicate why this variable should be controlled. 2 marks

\_\_\_\_\_

\_\_\_\_\_

- f. Students performing the photoelectric experiment on a different metal have carefully determined the uncertainty in their measured values for the maximum kinetic energy of the emitted photoelectrons. This is represented by an uncertainty bar (or error bar) drawn on one of the data points in the graph below. The uncertainty in the values for frequencies may be neglected.

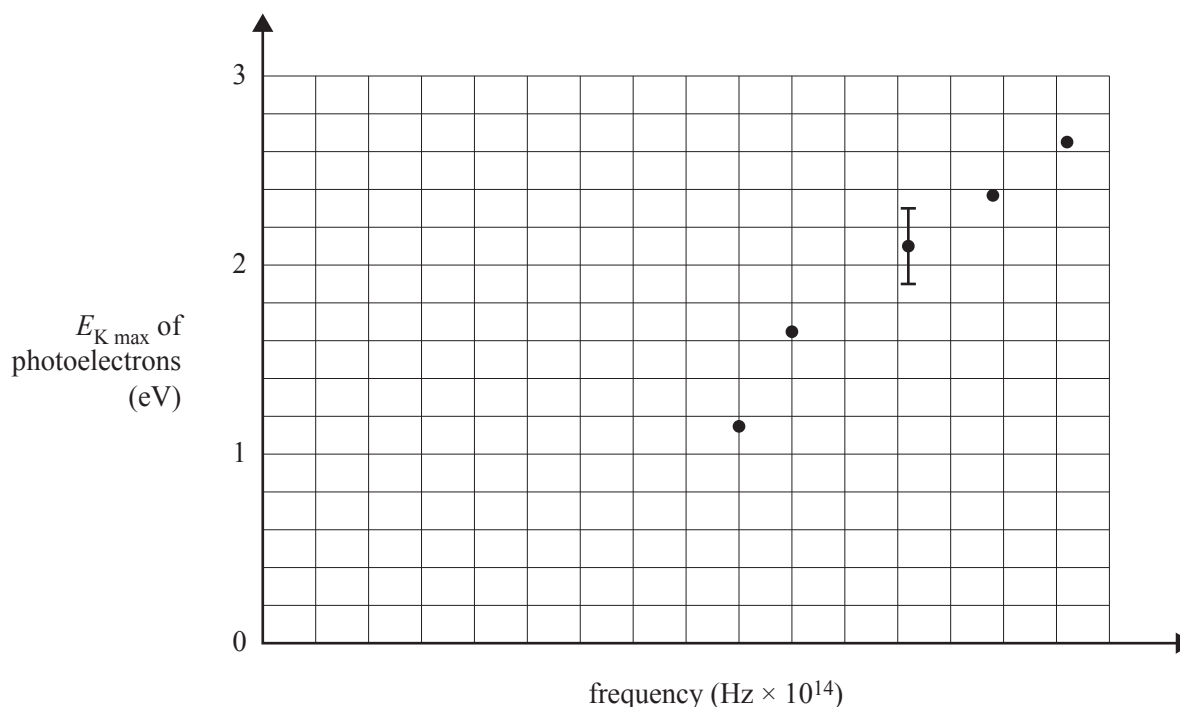

- On the graph above, show the steps needed to determine whether the data points may be fitted by a straight line. Explain your answer. 3 marks

\_\_\_\_\_

\_\_\_\_\_

\_\_\_\_\_

DO NOT WRITE IN THIS AREA

**Question 18** (11 marks)

- a. Outline Young’s double-slit experiment. Explain the implications of this experiment for understanding the nature of light.

3 marks

---

---

---

---

---

---

---

- b. Explain how a single-photon Young’s double-slit experiment can be used as evidence of the dual nature of light.

3 marks

---

---

---

---

---

---

---

DO NOT WRITE IN THIS AREA



**Answers to multiple-choice questions**

<b>Question</b>	<b>Answer</b>
1	C
2	C
3	C
4	A
5	B
6	A
7	D
8	A
9	A
10	D
11	B
12	B
13	A
14	D
15	B
16	D
17	B
18	D
19	C
20	C