



Units 3 and 4 Specialist Maths: Exam 2

Practice Exam Question and Answer Booklet

Duration: 15 minutes reading time, 2 hours writing time

Structure of book:

Section	Number of questions	Number of questions to be answered	Number of marks
A	22	22	22
B	5	5	58
		Total	80

- Students are permitted to bring into the examination room: pens, pencils, highlighters, erasers and rulers, one bound reference, one approved CAS calculator (memory does not need to be cleared) and, if desired, one scientific calculator.
- Students are not permitted to bring into the examination room: blank sheets of paper and/or white out liquid/tape.

Materials supplied:

- This question and answer booklet of 22 pages, including a sheet of miscellaneous formulas.

Instructions:

- You must complete all questions of the examination.
- Write all your answers in the spaces provided in this booklet.

Section A – Multiple-choice questions

Instructions

Answer all questions by circling your choice.

Choose the response that is correct or that best answers the question.

A correct answer scores 1, an incorrect answer scores 0.

Marks will not be deducted for incorrect answers.

No marks will be given if more than one answer is completed for any question.

Questions

Question 1

Suppose $z^3 = -8$. If z is a complex number, which of the following is a possible value for z ?

- A. $1 - \sqrt{3}i$
- B. $\sqrt{3} + i$
- C. $\sqrt{3} - i$
- D. -8
- E. 2

Question 2

Which of the following describes the shaded area in the Argand diagram below?

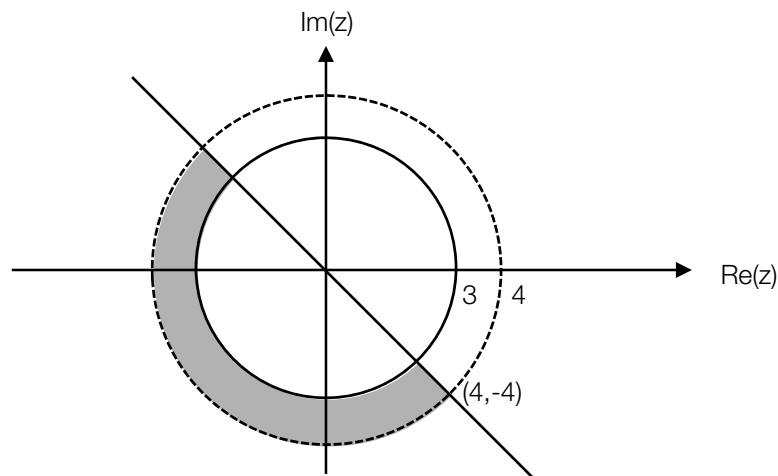

- A. $S = \{z \in \mathbb{C} : 3 \leq (z\bar{z}) \text{ and } \operatorname{Re}(z) < \operatorname{Im}(z)\}$
- B. $S = \{z \in \mathbb{C} : 3 \leq |z - 2i| \leq 4 \text{ and } \operatorname{Arg}(z) \geq \frac{3\pi}{4}\}$
- C. $S = \{z \in \mathbb{C} : (z - 3)(\bar{z} - 4) \leq 1 \text{ and } |z - i| \leq |z - 1|\}$
- D. $S = \{z \in \mathbb{C} : 3 \leq |z| < 4 \text{ and } |z + i| \leq |z - 1|\}$
- E. $S = \{z \in \mathbb{C} : \operatorname{Im}(z) = \operatorname{Re}(z) \times \operatorname{Arg}(z)\}$

Question 3

The graph of $y = \operatorname{cosec}(2x + \frac{\pi}{4})$, from $x = -\pi$ to $x = \pi$, has vertical asymptotes at:

- A. $x = -\frac{3\pi}{4}, -\frac{\pi}{4}, \frac{\pi}{4}, \frac{3\pi}{4}$
 B. $x = -\frac{5\pi}{8}, -\frac{\pi}{8}, \frac{3\pi}{8}, \frac{7\pi}{8}$
 C. $x = -\frac{7\pi}{8}, -\frac{3\pi}{8}, \frac{\pi}{8}, \frac{5\pi}{8}$
 D. $x = -\frac{5\pi}{6}, -\frac{2\pi}{6}, \frac{\pi}{6}, \frac{4\pi}{6}$
 E. $x = -\pi, -\frac{\pi}{2}, \frac{\pi}{2}, \pi$

Question 4

Find the area enclosed by the functions $y = \tan^{-1}(\pi x)$ and $y = \frac{x^3}{8}$ correct to 2 decimal places.

- A. 1.79
 B. 0
 C. 4.45
 D. 3.58
 E. 2.20

Question 5

A conical funnel is being drained at a constant rate. It has a diameter of 100 mm and a slant height of 130 mm. If the depth of water in the funnel is decreasing at a rate of $\frac{5}{4\pi}$ mm/s, find an expression describing the volume of water leaving the funnel per second.

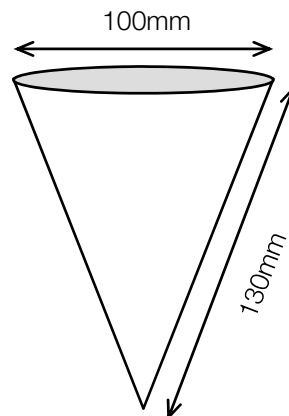

- A. $\frac{5h^2}{4}$
 B. $\frac{64h^2}{125}$
 C. $\frac{36h^2}{5}$
 D. $\frac{25h^2}{4}$
 E. $\frac{5h^2}{24}$

Question 6

Find k such that $y = Ae^{kx}$ is a solution to the differential equation $\frac{d^2y}{dx^2} = -4\left(\frac{dy}{dx} + y\right)$ for any real number A .

- A. 2
- B. -2
- C. 0
- D. 4
- E. -4

Question 7

Given that the line \overline{AC} passes through the centre of the circle, express the length of \overline{BD} in terms of α and the radius, r .

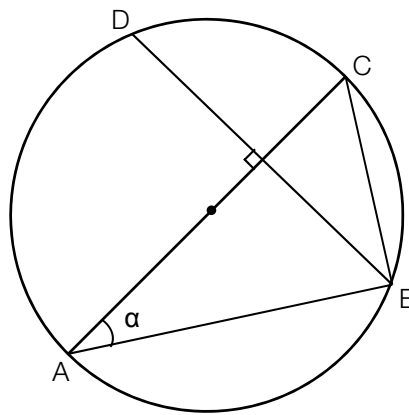

- A. $4r \sin^2 \alpha$
- B. $2r \sin(2\alpha)$
- C. $2r^2 \cos \alpha$
- D. $\sqrt{2} \tan^2 \alpha$
- E. $4r^2 \cos \alpha$

Question 8

Find the vector resolute of $\mathbf{a} = 3\mathbf{i} - 4\mathbf{j} + \mathbf{k}$ in the direction of $\mathbf{b} = \mathbf{i} + 2\mathbf{j} - \mathbf{k}$.

- A. $2\mathbf{i} + 4\mathbf{k}$
- B. $-\mathbf{i} - 2\mathbf{j} + \mathbf{k}$
- C. $4\mathbf{i} - 2\mathbf{j}$
- D. $-2\mathbf{i} + 6\mathbf{j} - 2\mathbf{k}$
- E. $2\mathbf{i} - 4\mathbf{j} + \mathbf{k}$

Question 9

Given $\cos \theta = \frac{2}{7}$, find $\tan^{-1}(\sin \theta)$ correct to 2 decimal places.

- A. 1.48
- B. 43.7
- C. 0.76
- D. 1.29
- E. 0.29

Question 10

An antiderivative of $f(x) = \frac{2}{4x^2+12x+10}$ is:

- A. $\tan^{-1}(2x + 3)$
- B. $\frac{x}{\sqrt{2}(4x^2+12x+11)}$
- C. $\tan(\sqrt{2}x + 3/2)$
- D. $\frac{\sqrt{2} \log_e |4x^2+12x+11|}{4}$
- E. $-\frac{3 \tan^{-1}(2x+3)}{2}$

Question 11

A 6 kg block is stationary on an inclined plane. If the coefficient of static friction is $\mu = 0.5$, what is the magnitude and direction of the frictional force acting on the block?

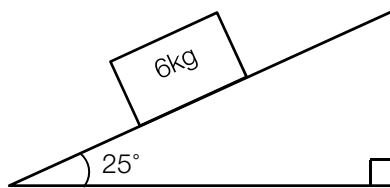

- A. 24.9 N down the plane
- B. 26.6 N up the plane
- C. 0 N
- D. 24.9 N up the plane
- E. 26.6 N down the plane

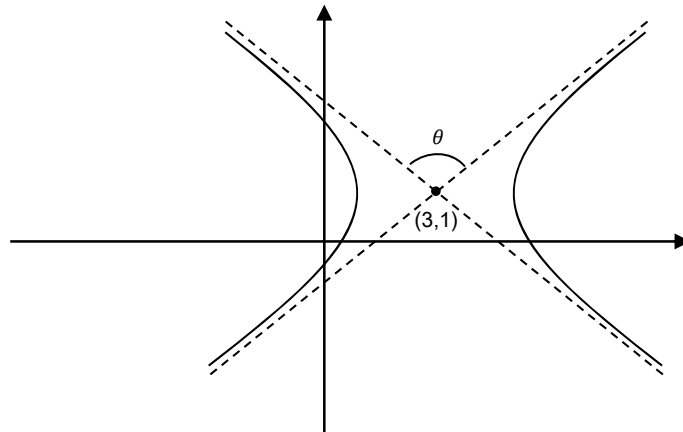
Question 12

If $\theta = \frac{\pi}{3}$, which of the following most accurately describes the hyperbola shown below?

- A. $(x - 3)^2 - \frac{(y-1)^2}{3} = 1$
- B. $\frac{(x-3)^2}{4} - \frac{(y+1)^2}{9} = 1$
- C. $(x + 3)^2 - \frac{(y+1)^2}{9} = 1$
- D. $-(x - 3)^2 + (y - 1)^2 = 3$
- E. $3(x - 3)^2 - (y + 1)^2 = 9$

Question 13

A solid is constructed by rotating the function $y = 1 - \cos(2x)$, where $0 \leq x \leq \frac{\pi}{2}$, about the y-axis. What is the volume of the solid?

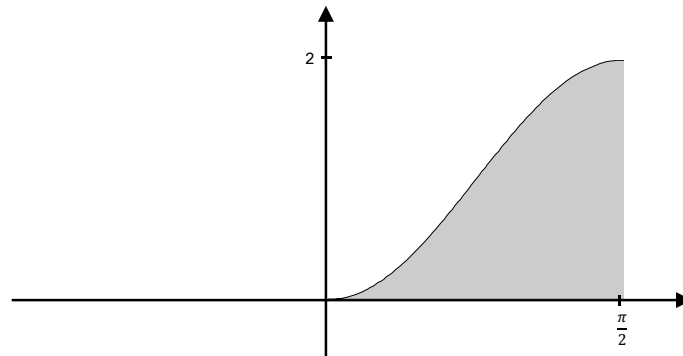

- A. $\frac{\pi(\pi^2-4)}{4}$
 B. $\frac{-\pi(\pi^2-20)}{4}$
 C. $\frac{\pi^3}{2}$
 D. $\frac{-\pi(\pi^2-4\pi-4)}{4}$
 E. $\frac{\pi(\pi^2+4)}{4}$

Question 14

$\frac{2x-5}{x(x^2+1)}$, expressed as a partial fraction, has the form:

- A. $\frac{A}{x} + \frac{B}{x+1} + \frac{C}{x-1}$
 B. $\frac{A}{x} + \frac{B}{x^2+1}$
 C. $\frac{A+Bx}{x} + \frac{C}{x^2+1}$
 D. $\frac{A}{x} + \frac{Bx+C}{x^2+1}$
 E. $\frac{A+Bx}{x} + \frac{C}{x+1} + \frac{D}{x-1}$

Question 15

The derivative of a polynomial function, $F(x)$, is shown.

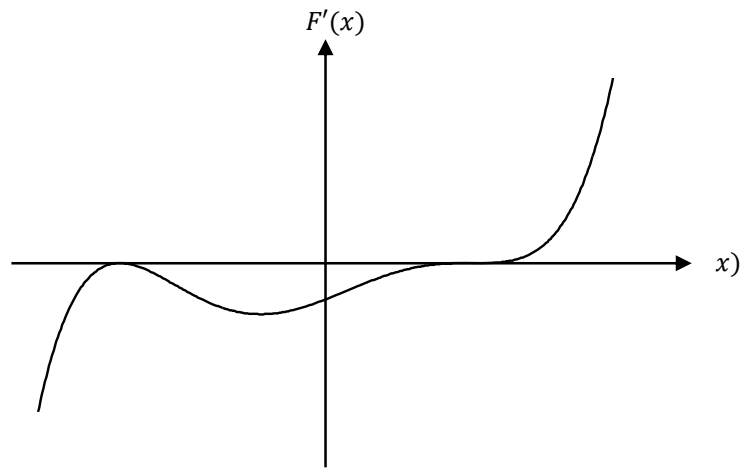

Which of the following could be $F(x)$?

A.

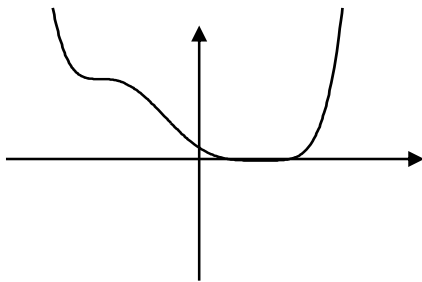

B.

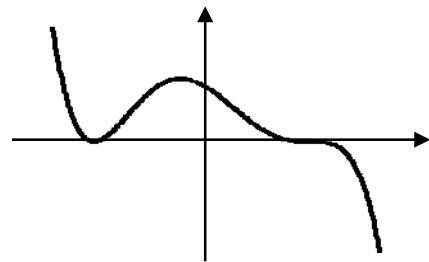

C.

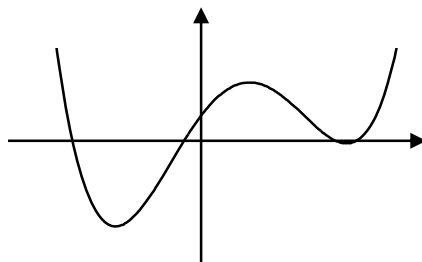

D.

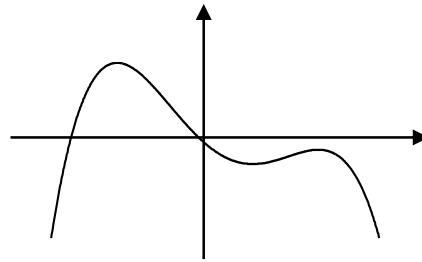

E.

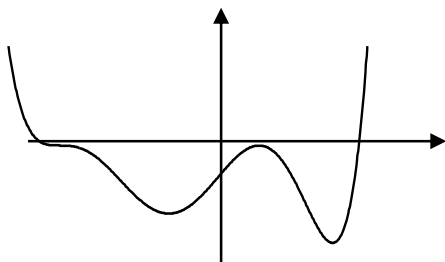

Question 16

Suppose $y = \sin(2x) - \cos(2x)$. Which of the following is true?

- A. $\frac{d^2y}{dx^2} - \frac{dy}{dx} + y = 0$
- B. $\frac{d^2y}{dx^2} + \frac{dy}{dx} + 4y = 2(\cos(2x) + \sin(2x))$
- C. $2\frac{d^2y}{dx^2} - 3\frac{dy}{dx} + y = \cos(2x) - \sin(2x)$
- D. $4\frac{d^2y}{dx^2} - 2\frac{dy}{dx} - y = \cos(4x) + \sin(2x)$
- E. $-\frac{d^2y}{dx^2} + 2\frac{dy}{dx} + 3y = 0$

Question 17

A particle experiences 3 forces as shown.

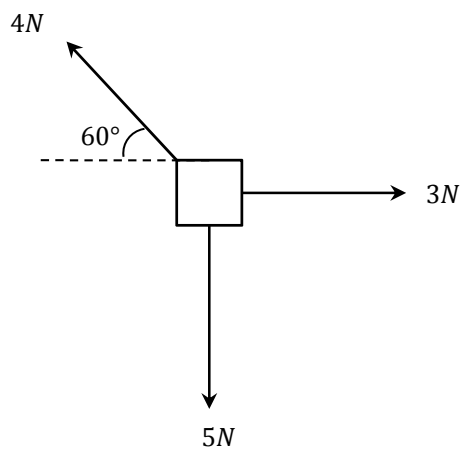

What is the magnitude of the resultant force?

- A. 0 N
- B. 2.80 N
- C. 1.83 N
- D. 2.00 N
- E. 0.46 N

Question 18

Two graph of velocity-time graph of two motorists is shown below.

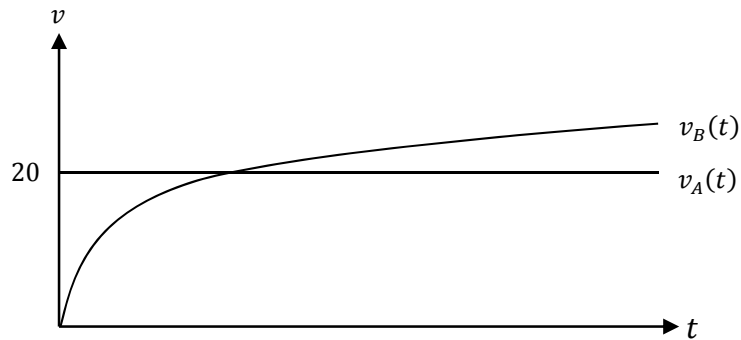

If $v_B(t) = 5\sqrt{t}$, and if they both start from the same position, at what time does cyclist A pass cyclist B?

- A. $t = 12$
- B. $t = 24$
- C. $t = 36$
- D. $t = 48$
- E. $t = 60$

Question 19

The slope field of a certain differential equation is shown below:

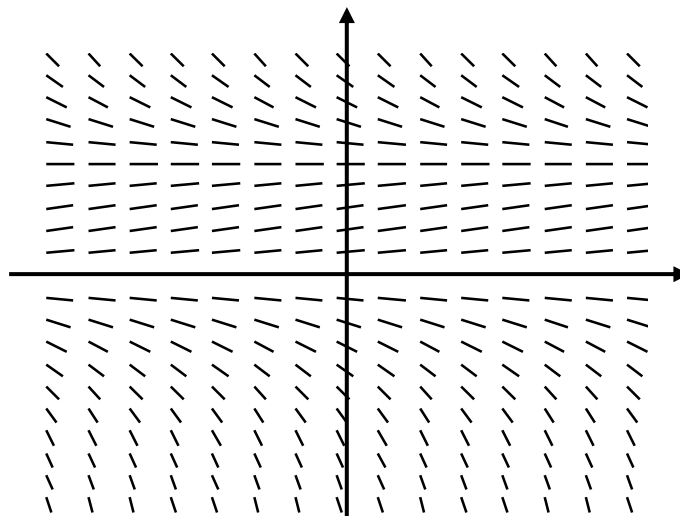

Which equation most accurately describes the slope field?

- A. $\frac{dy}{dx} = \sin(x) + \sin(y)$
- B. $\frac{dy}{dx} = xy^2$
- C. $\frac{dy}{dx} = y - y^2$
- D. $\frac{dy}{dx} = e^{x^2}$
- E. $\frac{dy}{dx} = x^2 - y^2$

Question 20

If the position of a particle is describe by $\mathbf{r}(t) = 2 \sin(t) \mathbf{i} + 2 \cos(t) \mathbf{j} + \frac{\pi^2}{t+\frac{\pi}{2}} \mathbf{k}$, where $t \geq 0$, the initial speed of the particle is:

- A. $\frac{\sqrt{5}}{2}$
- B. 2
- C. $\frac{\sqrt{17}}{2}$
- D. $2\sqrt{5}$
- E. $-\frac{\sqrt{17}}{2}$

Question 21

Using the same particle from question 20, what is a unit vector in the direction of travel at $t = \frac{\pi}{2}$?

- A. $\frac{2}{\sqrt{5}} \mathbf{i} + \frac{1}{\sqrt{5}} \mathbf{k}$
- B. $\sqrt{\frac{2}{5}} \mathbf{i} - \sqrt{\frac{2}{5}} \mathbf{j} + \frac{2\sqrt{5}}{5} \mathbf{k}$
- C. $-\frac{2}{\sqrt{5}} \mathbf{j} - \frac{1}{\sqrt{5}} \mathbf{k}$
- D. $-\sqrt{\frac{2}{5}} \mathbf{i} + \frac{2\sqrt{5}}{5} \mathbf{k}$
- E. $\sqrt{\frac{2}{5}} \mathbf{i} + 2\sqrt{\frac{2}{5}} \mathbf{j} + \frac{1}{\sqrt{5}} \mathbf{k}$

Question 22

A 5kg mass is accelerated from rest by a 10N force for 3 seconds, then by a 20N force for 2 seconds in the opposite direction. What is the final speed of the mass in ms^{-1} ?

- A. 2
- B. 8
- C. -2
- D. 0
- E. 6

Section B – Analysis

Instructions

Answer all questions in the spaces provided.

In all questions where a numerical answer is required an exact value must be given unless otherwise specified.

In questions where more than one mark is available, appropriate working must be shown.

Unless otherwise indicated, the diagrams in this book are not drawn to scale.

Questions

Question 1

a. i. Solve $z^3 = 1$, where $z \in \mathbb{C}$.

2 marks

ii. Plot and label the solutions on the Argand diagram below.

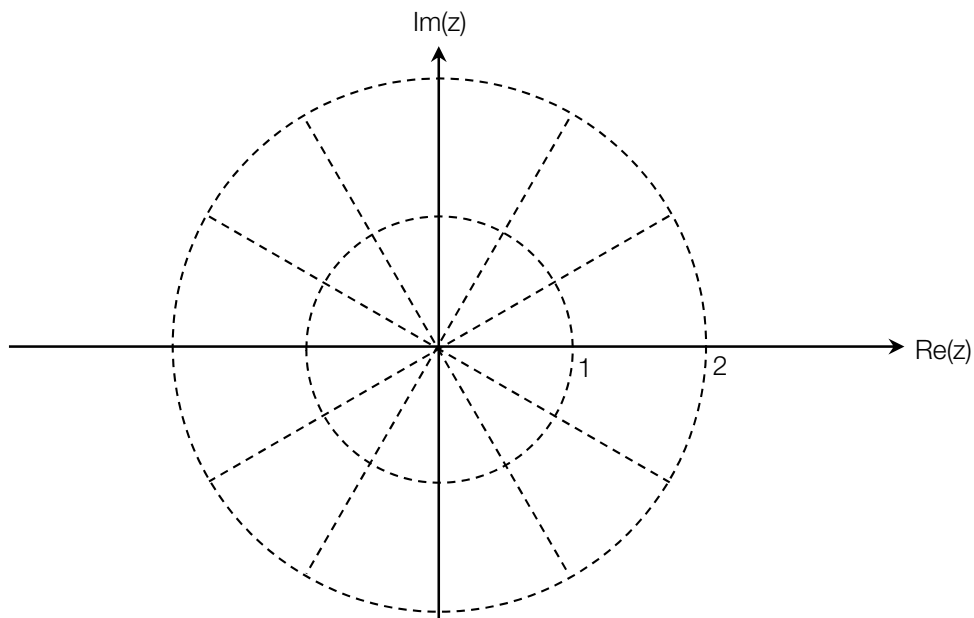

2 marks

- b. i. Suppose $z = w$ is a solution to $z^3 = 1$. Find $k \in \mathbb{C}$ such that $z = kw$ is a solution to $z^3 = i$.

2 marks

- ii. Hence or otherwise, find the solutions of $z^3 = i$ in polar form

2 mark

- c. Let z_1 be the solution of $z^3 = 1$ that lies in the second quadrant. Let z_2 be the solution of $z^3 = i$ that lies in the second quadrant. Find the Cartesian equation for the relation $|z - z_1| = |z - z_2|$.

2 marks

d. Sketch the region specified by

$$\{z: |z - iz_1| < |z + iz_1|\} \cap \{z: |z - iz_2| \geq |z + iz_2|\} \cap \{z: 1 < |z| \leq 2\}$$

on the Argand diagram below.

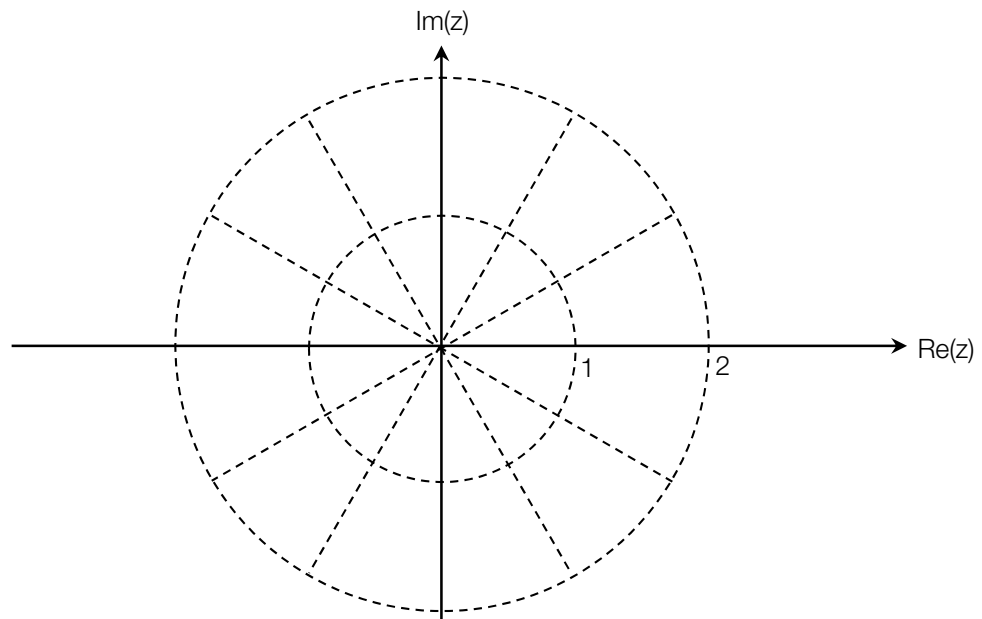

3 marks

Total: 13 marks

Question 2

Consider the function $f(x) = -3 \tan^{-1} x + \frac{2x}{x^2+1} + \frac{x^3}{3} + x$

- a. i. Show that $f'(x) = \frac{x^2(x^4+3x^2-2)}{(x^2+1)^2}$

3 marks

- ii. Hence find the exact values of x for which $f'(x)$ is zero

4 marks

Question 3

A 20m^3 horizontal cylindrical tank is being drained of water at a rate of 2m^3 per minute. The tank and its cross-section of the tank are shown below, where O is the center of the circle and P is the point on the circumference of the circle in line with the water level. The tank has radius of 1 metre and a length of L metres.

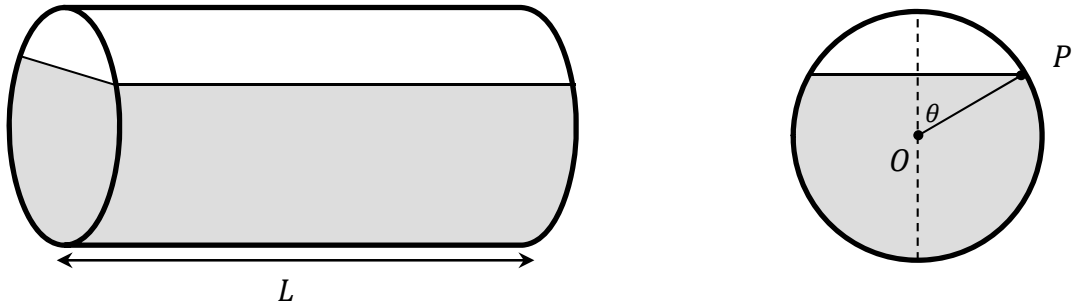

- a. Find the length of the tank, L

1 mark

- b. i. Find the area of the unshaded segment in the cross-section in terms of θ

2 marks

- ii. Hence show that the amount of water remaining in the tank can be expressed as:

$$V = 20 - \frac{L}{2}(2\theta - \sin(2\theta)), 0 \leq \theta \leq \pi, \text{ where } L \text{ is the value you obtained in part a.}$$

2 marks

iii. Hence find $\frac{d\theta}{dt}$ in terms of θ

3 marks

c. Starting at $\theta = 0$, and with step size of $\Delta t = 0.1$, find an approximation for $\theta(0.3)$ using Euler's method, correct to 3 decimal places.

3 marks

Total: 11 marks

Question 4

A leaf on the ground is caught in an updraft and subsequently follows an irregular path given by the position vector, $\mathbf{r}(t) = 2t\mathbf{i} + \left(2e^{-\frac{t^2}{10}} \cos \frac{\pi t}{5}\right)\mathbf{j} + \left(2e^{-\frac{t^2}{10}} \sin \frac{\pi t}{5}\right)\mathbf{k}$, for $0 \leq t \leq 5$.

- a. Show that the displacement of the leaf can be expressed as $|\mathbf{r}(t)| = 2\sqrt{t^2 + e^{-\frac{t^2}{5}}}$

2 marks

- b. Find $\dot{\mathbf{r}}(t)$

3 marks

- c. Using parts a. and b., write, correct to 2 decimal places, the speed of the leaf, and the corresponding displacement at $t = 5$

2 marks

Total: 7 marks

Question 5

A 5 kg spherical mass is sliding down a parabolic ramp. The cross-section of the ramp is given by the area enclosed by the lines $y = \frac{x^2}{4}$, $x = k$ and $y = 0$. Assume there is negligible friction. All units are in meters.

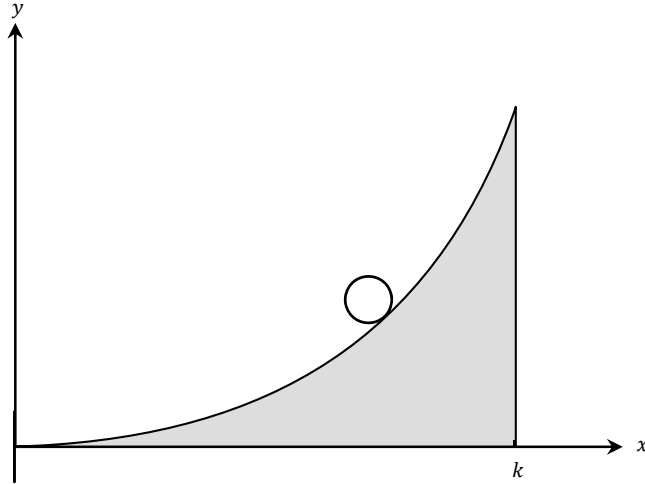

- a. Given that the normal force experienced by the ball is perpendicular to the surface of the ramp, find an expression for the normal force at each point on the ramp in the form $F_{normal} = f_1(x)\mathbf{i} + f_2(x)\mathbf{j}$, where \mathbf{i} and \mathbf{j} are unit vectors parallel to the x and y axis, respectively.

4 marks

Formula sheet

Mensuration

area of a trapezium	$\frac{1}{2}(a + b)h$
curved surface area of a cylinder	$2\pi rh$
volume of a cylinder	$\pi r^2 h$
volume of a cone	$\frac{1}{3}\pi r^2 h$
volume of a pyramid	$\frac{1}{3}Ah$
volume of a sphere	$\frac{4}{3}\pi r^3$
area of a triangle	$\frac{1}{2}bc \sin A$
sine rule	$\frac{a}{\sin A} = \frac{b}{\sin B} = \frac{c}{\sin C}$
cosine rule	$c^2 = a^2 + b^2 - 2ab \cos C$

Coordinate geometry

ellipse	$\frac{(x - h)^2}{a^2} + \frac{(y - k)^2}{b^2} = 1$	hyperbola	$\frac{(x - h)^2}{a^2} - \frac{(y - k)^2}{b^2} = 1$
---------	---	-----------	---

Circular (trigonometric) functions

$$\cos^2(x) + \sin^2(x) = 1$$

$$1 + \tan^2(x) = \sec^2(x)$$

$$\sin(x + y) = \sin(x) \cos(y) + \cos(x) \sin(y)$$

$$\cos(x + y) = \cos(x) \cos(y) - \sin(x) \sin(y)$$

$$\tan(x + y) = \frac{\tan(x) + \tan(y)}{1 - \tan(x) \tan(y)}$$

$$\cos(2x) = \cos^2(x) - \sin^2(x) = 2 \cos^2(x) - 1 = 1 - 2 \sin^2(x)$$

$$\sin(2x) = 2 \sin(x) \cos(x)$$

$$\cot^2(x) + 1 = \operatorname{cosec}^2(x)$$

$$\sin(x - y) = \sin(x) \cos(y) - \cos(x) \sin(y)$$

$$\cos(x - y) = \cos(x) \cos(y) + \sin(x) \sin(y)$$

$$\tan(x - y) = \frac{\tan(x) - \tan(y)}{1 + \tan(x) \tan(y)}$$

$$\tan(2x) = \frac{2 \tan(x)}{1 - \tan^2(x)}$$

function	\sin^{-1}	\cos^{-1}	\tan^{-1}
domain	$[-1, 1]$	$[-1, 1]$	\mathbb{R}
range	$\left[-\frac{\pi}{2}, \frac{\pi}{2}\right]$	$[0, \pi]$	$\left(-\frac{\pi}{2}, \frac{\pi}{2}\right)$

Algebra (complex numbers)

$$z = x + yi = r(\cos \theta + i \sin \theta) = r \operatorname{cis} \theta$$

$$z^n = r^n \operatorname{cis}(n\theta) \text{ (de Moivre's theorem)}$$

$$|z| = \sqrt{x^2 + y^2} = r$$

$$-\pi < \operatorname{Arg} z \leq \pi$$

$$z_1 z_2 = r_1 r_2 \operatorname{cis}(\theta_1 + \theta_2)$$

$$\frac{z_1}{z_2} = \frac{r_1}{r_2} \operatorname{cis}(\theta_1 - \theta_2)$$

Calculus

$$\frac{d}{dx}(x^n) = nx^{n-1}$$

$$\int x^n dx = \frac{1}{n+1} x^{n+1} + c, n \neq -1$$

$$\frac{d}{dx}(e^{ax}) = ae^{ax}$$

$$\int e^{ax} dx = \frac{1}{a} e^{ax} + c$$

$$\frac{d}{dx}(\log_e x) = \frac{1}{x}$$

$$\int \frac{1}{x} dx = \log_e |x| + c$$

$$\frac{d}{dx}(\sin(ax)) = a \cos(ax)$$

$$\int \sin(ax) dx = -\frac{1}{a} \cos(ax) + c$$

$$\frac{d}{dx}(\cos(ax)) = -a \sin(ax)$$

$$\int \cos(ax) dx = \frac{1}{a} \sin(ax) + c$$

$$\frac{d}{dx}(\tan(ax)) = \frac{a}{\cos^2(ax)} = a \sec^2(ax)$$

$$\int \sec^2(ax) dx = \frac{1}{a} \tan(ax) + c$$

$$\frac{d}{dx}(\sin^{-1}(x)) = \frac{1}{\sqrt{1-x^2}}$$

$$\int \frac{1}{\sqrt{a^2-x^2}} dx = \sin^{-1}\left(\frac{x}{a}\right) + c, a > 0$$

$$\frac{d}{dx}(\cos^{-1}(x)) = -\frac{1}{\sqrt{1-x^2}}$$

$$\int \frac{-1}{\sqrt{a^2-x^2}} dx = \cos^{-1}\left(\frac{x}{a}\right) + c, a > 0$$

$$\frac{d}{dx}(\tan^{-1}(x)) = \frac{1}{1+x^2}$$

$$\int \frac{a}{a^2+x^2} dx = \tan^{-1}\left(\frac{x}{a}\right) + c$$

product rule

$$\frac{d}{dx}(uv) = u \frac{dv}{dx} + v \frac{du}{dx}$$

quotient rule

$$\frac{d}{dx}\left(\frac{u}{v}\right) = \frac{\left(v \frac{du}{dx} - u \frac{dv}{dx}\right)}{v^2}$$

chain rule

$$\frac{dy}{dx} = \frac{dy}{du} \frac{du}{dx}$$

Euler's method

$$\text{If } \frac{dy}{dx} = f(x), x_0 = a \text{ and } y_0 = a, \text{ then } y_{n+1} = y_n + hf(x_n)$$

acceleration

$$a = \frac{d^2x}{dt^2} = \frac{dv}{dt} = v \frac{dv}{dx} = \frac{d}{dx}\left(\frac{1}{2}v^2\right)$$

constant (uniform) acceleration

$$v = u + at, s = ut + \frac{1}{2}at^2, v^2 = u^2 + 2as, s = \frac{1}{2}(u+v)t$$

Vectors in two and three dimensions

$$\mathbf{r} = x\mathbf{i} + y\mathbf{j} + z\mathbf{k}$$

$$|\mathbf{r}| = \sqrt{x^2 + y^2 + z^2} = r$$

$$\mathbf{r} = \frac{d\mathbf{r}}{dt} = \frac{dx}{dt}\mathbf{i} + \frac{dy}{dt}\mathbf{j} + \frac{dz}{dt}\mathbf{k}$$

$$\mathbf{r}_1 \cdot \mathbf{r}_2 = r_1 r_2 \cos \theta = x_1 x_2 + y_1 y_2 + z_1 z_2$$

Mechanics

momentum $\mathbf{p} = m\mathbf{v}$

equation of motion $\mathbf{R} = m\mathbf{a}$

friction $F \leq \mu N$