



Units 3 and 4 Specialist Maths: Exam 2

Practice Exam Solutions

Stop!

Don't look at these solutions until you have attempted the exam.

Any questions?

Check the Engage website for updated solutions, then email practiceexams@ee.org.au.

Section A – Multiple-choice questions

Question 1

The correct answer is D.

The graph is the sum of a parabola and a negative rectangular hyperbola: $x^2 - \frac{1}{x}$. This can also be written as $\frac{x^3-1}{x}$.

Question 2

The correct answer is B.

The equation $4x^2 - 12x + 9 = 0$ has one solution, so there will only be one vertical asymptote. For an inverse quadratic, there is also always a horizontal asymptote, so $f(x)$ will have two asymptotes in total.

Question 3

The correct answer is C.

Question 4

The correct answer is B.

$-1 \leq \frac{x}{4} - 1 \leq 1$ and $-\frac{\pi}{2} \leq \sin^{-1} a \leq \frac{\pi}{2}$, from formula sheet.

Rearranging these gives:

$$0 \leq x \leq 8 \text{ and } 0 \leq 2 \sin^{-1} a + \pi \leq 2\pi$$

Question 5

The correct answer is C.

Solving the equation $z^8 = -i + 2i = i$ gives 8 solutions $\frac{2\pi}{8} = \frac{\pi}{4}$ radians apart from each other.

$z^8 = cis\left(\frac{\pi}{2}\right) \Rightarrow |z| = 1$. This rules out options B, D and E. Option A claims $z = i$ is a solution, but $(i)^8 \neq i$, so option A is incorrect. By elimination, the answer is C.

Question 6

The correct answer is B.

Question 7

The correct answer is D.

Question 8

The correct answer is D.

Question 9

The correct answer is C.

As the derivative function has two stationary points, the function itself has two points of inflexion (one of these is a stationary point of inflexion). For the function to have a turning point, the graph of the derivative function must cross the x axis (change sign), hence the function has one turning point only.

Question 10

The correct answer is D.

Resolving perpendicular to the plane:

$F_{\perp} = T \sin(30) - W \cos(17) = 30 \sin(30) - 10 \times 9.8 \cos(17) \approx -79$. Hence the weight force of the block far exceeds the component of T perpendicular to the plane, the block does not lift from the plane. (we assume the strength of the plane is more or less infinite and can support the mass without problem)

Resolving parallel to the plane:

$F_{\parallel} = T \cos(30) - W \sin(17) \approx -2.67$. The weight force exceeds the horizontal component of T (just!), so the net force acts down the plane, causing the block to accelerate down the plane.

Question 11

The correct answer is A.

Question 12

The correct answer is C.

Question 13

The correct answer is D.

The conjugate factor theorem does not apply here, as P has complex coefficients. The cSolve function on a CAS yields four solutions, one of which is $z = i$.

Question 14

The correct answer is B.

Speed is the magnitude of the velocity.

Question 15

The correct answer is B.

Question 16

The correct answer is C.

Question 17

The correct answer is A.

$$a = \frac{d}{dx} \left(\frac{1}{2} v^2 \right)$$

Question 18

The correct answer is B.

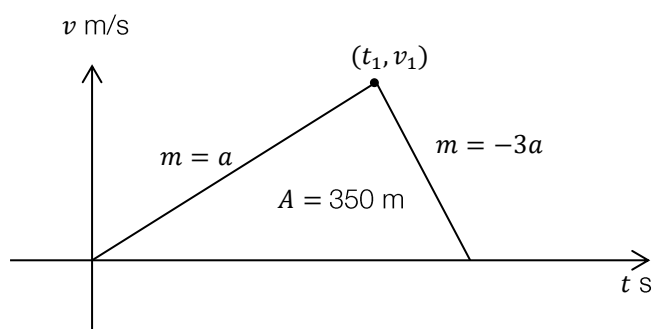
**Question 19**

The correct answer is E.

$\Delta P = m_2 v_2 - m_1 v_1$. Mass is constant and change in velocity will be negative, so change in momentum must be negative.

Question 20

The correct answer is A.

Truck is moving at constant speed, so net force acting on truck must be zero.

Question 21

The correct answer is B.

Under the null-hypothesis and two-sided test, the p-value is calculated by:

$$p = 2 \Pr(\bar{X} \leq 128 | \mu = 140)$$

$$p = 0.034.$$

The null-hypothesis implies $\mu = 140$ and $\sigma = \frac{40}{\sqrt{50}}$.

$$\text{normCDF}\left(-100000, 128, \frac{40}{\sqrt{50}}, 140\right)$$

$$0.01694742676$$

ans*2

$$0.03389485352$$

Question 22

The correct answer is E.

A is incorrect because statistical test does not give **proof**.

B is incorrect because $0.01 \leq p \leq 0.05$, indicating rejection at 0.05 and non-rejection at 0.01.

C is incorrect because while p is greater than 0.01 and null hypothesis is 'not rejected', that does not equate rejection of alternative hypothesis.

D is incorrect because null hypothesis is not rejected at significance level 0.01.

E is correct because at significance level 0.05, p is less than 0.05 and hence, the null hypothesis is rejected and hence, 'no change' is rejected.

Section B – Short-answer questions

Marks allocated are indicated by a number in square brackets, for example, [1] indicates that the line is worth one mark.

Question 1a i

From the formula sheet, the domain of an inverse tan function is \mathbb{R} . Hence P is \mathbb{R} . [1].

Question 1a ii

From the formula sheet, $-\frac{\pi}{2} < \tan^{-1}(a) < \frac{\pi}{2}$.

$$-\frac{3\pi}{2} < 3 \tan^{-1}(a) < \frac{3\pi}{2}$$

$$-\frac{3\pi}{2} - \pi < 3 \tan^{-1}(2 - x) - \pi < \frac{3\pi}{2} - \pi$$

$$\therefore \text{ran } f = \left(-\frac{5\pi}{2}, \frac{\pi}{2}\right) [1]$$

Question 1b

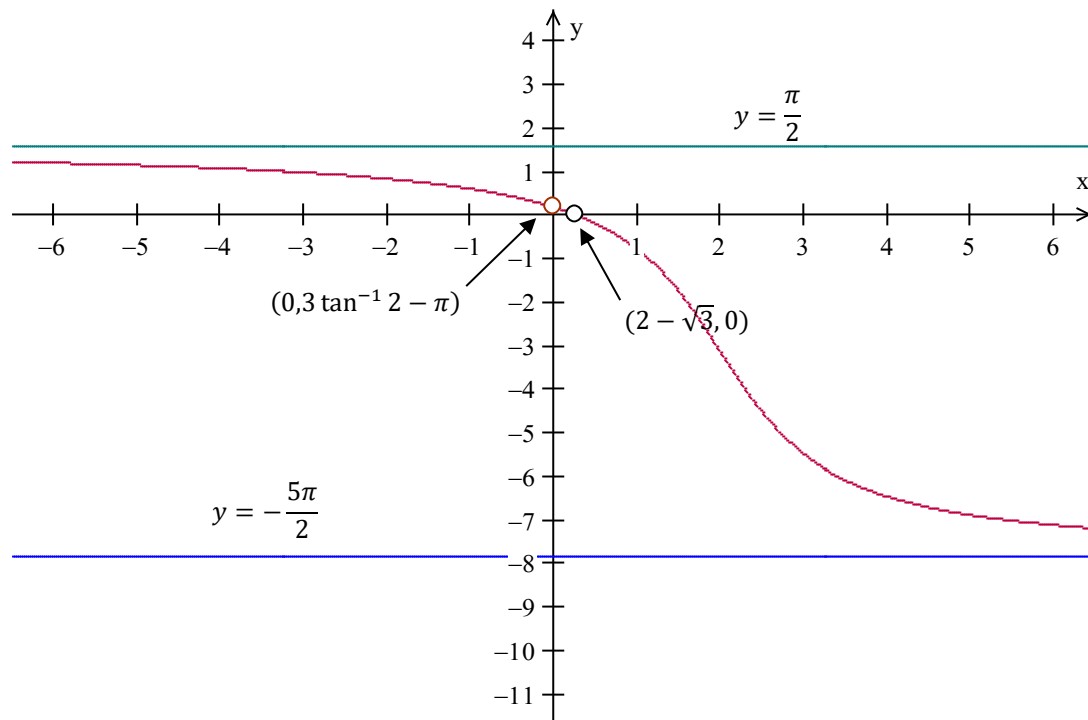

general graph shape [1], intercepts [1], correctly labelled asymptotes [1]

Question 1c i

Area between two curves: $\left| \int_a^b f(x) - g(x) dx \right|$

$$a = 0, f(b) = -\pi \Rightarrow b = 2$$

$$A = \left| \int_0^2 (3 \tan^{-1}(2 - x) - \pi) - (-\pi) dx \right|$$

$$A = \left| \int_0^2 (3 \tan^{-1}(2 - x)) dx \right| [2]$$

Question 1c ii

$$A \approx 4.228735$$

$$\begin{aligned} V &= l \times A \\ &= 30 \times 4.228735 \text{ [1]} \end{aligned}$$

$$V = 126.8621 \text{ m}^3 \text{ [1]}$$

Question 2a

$$\text{Resolving in x direction, } v_x = 30 \cos(30^\circ) = 15\sqrt{3}$$

$$\text{Resolving in y direction, } v_y = 30 \sin(30^\circ) = 15$$

$$\therefore \mathbf{v}_i = 15\sqrt{3}\mathbf{i} + 15\mathbf{j} \text{ [2]}$$

Question 2b i

$$a = -9.8 \text{ m/s}^2 \text{ in the y direction. } a \text{ is constant, therefore } \mathbf{a}(t) = 0\mathbf{i} - 9.8\mathbf{j}$$

Question 2b ii

$$\begin{aligned} \mathbf{v}(t) &= \int \mathbf{a}(t) dt = \int (0\mathbf{i} + (-9.8)\mathbf{j}) dt \\ &= (c_1)\mathbf{i} + (c_2 - 9.8t)\mathbf{j}, c_1, c_2 \in \mathbb{R} \text{ [1]} \\ \mathbf{v}_i &= 15\sqrt{3}\mathbf{i} + 15\mathbf{j} \Rightarrow c_1 = 15\sqrt{3} \text{ and } c_2 = 15 \\ \therefore \mathbf{v}(t) &= 15\sqrt{3}\mathbf{i} + (15 - 9.8t)\mathbf{j} \text{ [1]} \\ \mathbf{r}(t) &= \int 15\sqrt{3}\mathbf{i} + (15 - 9.8t)\mathbf{j} dt \\ &= (c_3 + 15\sqrt{3}t)\mathbf{i} + (c_4 + 15t - 4.9t^2)\mathbf{j}, c_3, c_4 \in \mathbb{R} \\ \mathbf{r}_i &= 0\mathbf{i} + 0\mathbf{j} \Rightarrow c_3 = 0 \text{ and } c_4 = 0 \\ \therefore \mathbf{r}(t) &= (15\sqrt{3}t)\mathbf{i} + (15t - 4.9t^2)\mathbf{j} \end{aligned}$$

Question 2c i

$$\begin{aligned} \text{speed} &= |\mathbf{v}(t)| \\ \mathbf{v}(t) &= (5\sqrt{3})\mathbf{i} + (5 - 9.8t)\mathbf{j} \text{ [1]} \\ |\mathbf{v}(t)| &= \sqrt{(5\sqrt{3})^2 + (5 - 9.8t)^2} \\ &= \sqrt{96.04t^2 + 98t + 100} \text{ m/s [1]} \end{aligned}$$

Question 2c ii

$$\text{Min speed} = \sqrt{75} \text{ m s}^{-1}$$

Question 2c iii

Particle's flight ends when it returns to the ground, ie $y(t) = 0$

$$\begin{aligned} 15t - 4.9t^2 &= 0 \text{ [1]} \\ t(15 - 4.9t) &= 0 \rightarrow \text{disregard solution } t = 0 \\ \therefore 15 - 4.9t &= 0 \Rightarrow t = \frac{15}{4.9} = \frac{150}{49} \text{ s} \end{aligned}$$

Question 2c iv

Displacement in the y direction is 0, so total displacement is given by $x\left(\frac{50}{49}\right)$

$$x\left(\frac{50}{49}\right) = 15\sqrt{3} \times \frac{150}{49} = 79.533 \text{ m}$$

Question 2d

$$\mathbf{a}(t) = 0\mathbf{i} - 9.8\mathbf{j}, \text{ as } \mathbf{v}(t) = \int \mathbf{a}(t)dt,$$

$$\mathbf{v}(t) = (c_1)\mathbf{i} + (c_2 - 9.8t)\mathbf{j}$$

$$\mathbf{v}_i = v \cos(\theta) \mathbf{i} + v \sin(\theta) \mathbf{j} \quad [1]$$

$$\Rightarrow \mathbf{v}(t) = (v \cos(\theta))\mathbf{i} + (v \sin(\theta) - 9.8t)\mathbf{j}$$

$$\mathbf{x}(t) = \int \mathbf{v}(t)dt = (c_3 + v \cos(\theta) t)\mathbf{i} + (c_4 + v \sin(\theta) t - 4.9t^2)\mathbf{j}$$

$$\mathbf{x}_i = 0\mathbf{i} + 0\mathbf{j}$$

$$\Rightarrow \mathbf{x}(t) = (v \cos(\theta) t)\mathbf{i} + (v \sin(\theta) t - 4.9t^2)\mathbf{j} \quad [1]$$

Net displacement X occurs when $x(t_1) = X$, such that $y(t_1) = 0$

$$v \sin(\theta) t - 4.9t^2 = 0 \Rightarrow t = \frac{v \sin(\theta)}{4.9} \text{ s} \quad [1]$$

$$X = v \cos(\theta) \times \left(\frac{v \sin(\theta)}{4.9} \right) = \frac{v^2}{9.8} \times 2 \sin(\theta) \cos(\theta) = \frac{v^2}{9} \sin(2\theta)$$

Max value of X will occur when $\sin(2\theta) = 1$, so $\theta = 45^\circ$ [1]

Question 3a

$$H_0: \mu = 145 \text{ kg} \quad [1]$$

$$H_1: \mu < 145 \text{ kg} \quad [1]$$

Question 3b

Under the null hypothesis, $\bar{X} \sim N\left(145, \frac{15^2}{15}\right)$ [1/2]

$$p = \Pr(\bar{X} \leq 140 \mid \mu = 145) \quad [1/2]$$

$$p = 0.098 \quad [1/2]$$

normCDF(-100000, 140, 15/(15^(1/2)), 145)

0.09835280123

Since p is greater than 0.05, the null hypothesis is not rejected. [1/2]

Question 3c

In order to reject the null hypothesis, p has to be smaller than or equal to 0.05

Hence:

$$p = \Pr(\bar{X} \leq 140 \mid \mu = 145) \leq 0.05 \quad [1]$$

$$\Pr\left(Z \leq \frac{140 - 145}{\frac{15}{\sqrt{n}}}\right) \leq 0.05$$

invNormCDF("L", 0.05, 1, 0)

-1.644853627

$$\frac{140-145}{\frac{15}{\sqrt{n}}} \leq -1.64 \quad [1]$$

$$\text{solve} \left(\frac{140-145}{\frac{15}{\sqrt{x}}} = -1.644853627, x \right)$$

$$\{x=24.34989109\}$$

$$n \geq 24.35$$

Hence, we need at least 25 pieces. [1]

Question 3d

The distribution will be normal, with mean 2900 kg and standard deviation of 67 kg. [1]

Question 4a i

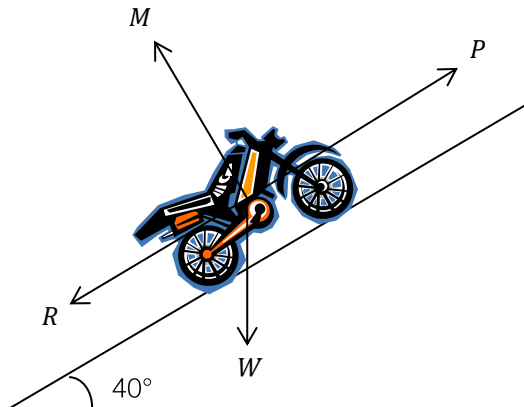

[1]

Question 4a ii

Resolving perpendicular to the plane:

$$F_{\perp} = M - W \sin(50^{\circ})$$

$$F_{\perp} = 0, \text{ so } M = 300g \sin(50^{\circ}) \text{ [1]}$$

Resolving parallel to the plane:

$$\begin{aligned} F_{\parallel} &= P - R - W \cos(50^{\circ}) \\ &= 10000 - (0.2N + 500) - 300g \cos(50^{\circ}) \\ &= 10000 - (0.2(300g \sin(50^{\circ})) + 500) - 300g \cos(50^{\circ}) \\ &= 7159.77 \text{ N [1]} \end{aligned}$$

$$a = \frac{F}{m} = \frac{7159.77}{300} = 23.8659 \text{ m/s}^2 \text{ [1]}$$

Question 4a iii

$$a = 23.8659 \text{ m/s}^2$$

$$u = 10 \frac{\text{m}}{\text{s}}, s = 10 \text{ m [1]}$$

$$v^2 = u^2 + 2as$$

$$v = \sqrt{10^2 + 2 \times 23.8659 \times 10} = 24.0274 \text{ m/s [1]}$$

Question 4b i

$$\mathbf{r}(t) = (25 \cos(40) t) \mathbf{i} + (25 \sin(40) t - 4.9t^2) \mathbf{j}$$

$$x = 25 \cos(40) t \Rightarrow t = \frac{x}{25 \cos(40)} [1]$$

$$y = 25 \sin(40) t - 4.9t^2 = 25 \sin(40) \frac{x}{25 \cos(40)} - 4.9 \left(\frac{x}{25 \cos(40)} \right)^2$$

$$\therefore y = 0.8391 - 0.0134x^2 [1]$$

Question 4b ii

It only makes sense to graph y against x for $x > 0, y > 0$.

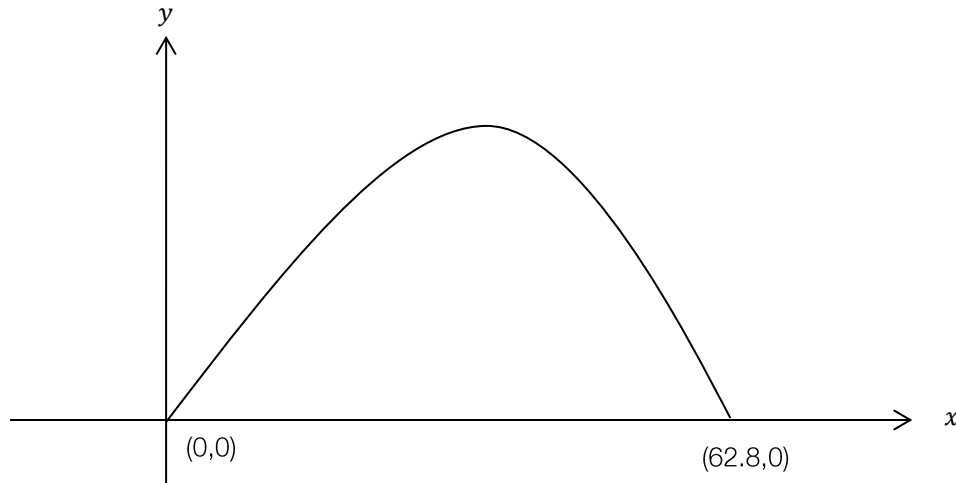

graph shape [1] intercepts [1]

Question 4c

The end of the ramp is a height $10 \sin(40) = 6.4 \text{ m}$ above ground. The total width of the cars is 20 m. From the above graph, it is evident she clears them easily. [2]

Question 5a

$$\begin{aligned} z &= \frac{2 + 2\sqrt{3}i}{2\sqrt{2} + 2\sqrt{2}i} \\ &= \frac{2 + 2\sqrt{3}i}{2\sqrt{2} + 2\sqrt{2}i} * \frac{2\sqrt{2} - 2\sqrt{2}i}{2\sqrt{2} - 2\sqrt{2}i} [1] \\ &= \frac{4\sqrt{2} + 4\sqrt{6}i - 4\sqrt{2}i - 4\sqrt{6}i^2}{4 * 2 - 4 * 2i^2} \\ &= \frac{\sqrt{6} + \sqrt{2}}{4} + \frac{\sqrt{6} - \sqrt{2}}{4} i [1] \end{aligned}$$

Question 5b i

$$|v| = |2 + 2\sqrt{3}i| = \sqrt{(2)^2 + (2\sqrt{3})^2} = 4$$

$$\text{As } v \text{ is in the first quadrant, } \text{Arg}(v) = \tan^{-1}\left(\frac{2\sqrt{3}}{2}\right) = \frac{\pi}{3}$$

$$\therefore v = 4 \text{ cis}\left(\frac{\pi}{3}\right) [1/2]$$

$$|w| = \sqrt{(2\sqrt{2})^2 + (2\sqrt{2})^2} = 4$$

$$\text{As } w \text{ is in the first quadrant, } \text{Arg}(w) = \tan^{-1}\left(\frac{2\sqrt{2}}{2\sqrt{2}}\right) = \frac{\pi}{4}$$

$$\therefore w = 4 \text{ cis}\left(\frac{\pi}{4}\right) [1/2]$$

$$z = \frac{v}{w} = \frac{4 \text{ cis}\left(\frac{\pi}{3}\right)}{4 \text{ cis}\left(\frac{\pi}{4}\right)} = \text{cis}\left(\frac{\pi}{3} - \frac{\pi}{4}\right) = \text{cis}\left(\frac{\pi}{12}\right) [1]$$

Question 5b ii

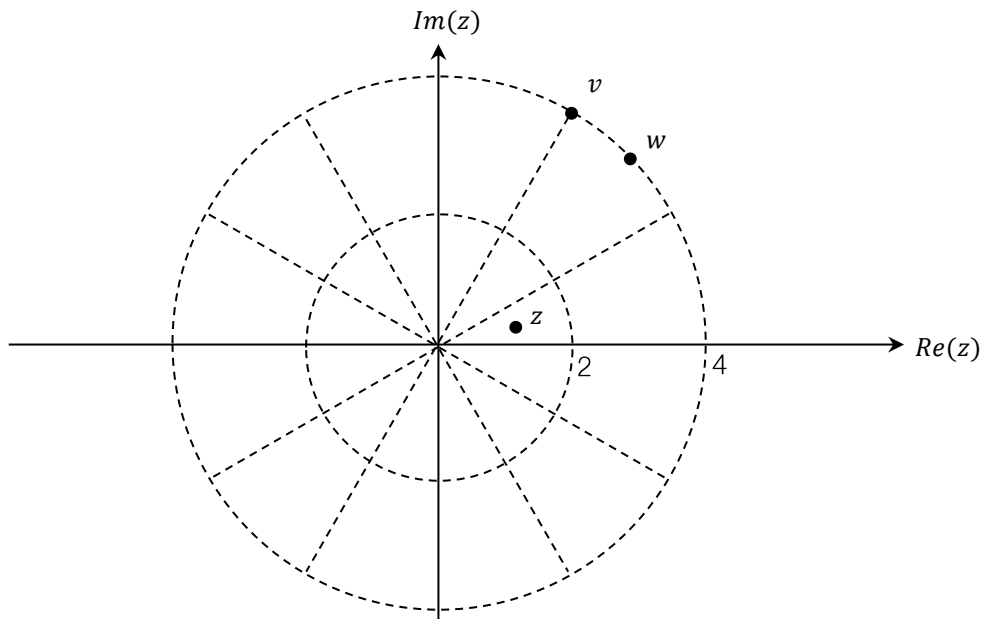

At least two correct [1]

All correct [1]

Question 5b iii

$$\begin{aligned}
 z &= \frac{\sqrt{6}+\sqrt{2}}{4} + \frac{\sqrt{6}-\sqrt{2}}{4}i = \operatorname{cis}\left(\frac{\pi}{12}\right) [1] \\
 &= \cos\left(\frac{\pi}{12}\right) + i \sin\left(\frac{\pi}{12}\right) \\
 \Rightarrow \cos\left(\frac{\pi}{12}\right) &= \frac{\sqrt{6}+\sqrt{2}}{4} \text{ and } \sin\left(\frac{\pi}{12}\right) = \frac{\sqrt{6}-\sqrt{2}}{4} \\
 \tan\left(\frac{\pi}{12}\right) &= \frac{\sin\left(\frac{\pi}{12}\right)}{\cos\left(\frac{\pi}{12}\right)} = \frac{\sqrt{6}-\sqrt{2}}{4} \div \frac{\sqrt{6}+\sqrt{2}}{4} [1] \\
 &= \frac{\sqrt{6}-\sqrt{2}}{\sqrt{6}+\sqrt{2}} = \frac{\sqrt{6}-\sqrt{2}}{\sqrt{6}+\sqrt{2}} \times \frac{\sqrt{6}-\sqrt{2}}{\sqrt{6}-\sqrt{2}} \\
 &= \frac{6-2\sqrt{2}\sqrt{6}+2}{6-2} = 2 - \sqrt{3} [1]
 \end{aligned}$$

Question 5c

$\left(z - \operatorname{cis}\left(\frac{\pi}{12}\right)\right)$ is a factor, so, by the conjugate factor theorem, $\left(z - \operatorname{cis}\left(-\frac{\pi}{12}\right)\right)$ is also a factor.

Hence $z = \operatorname{cis}\left(-\frac{\pi}{12}\right) = \frac{\sqrt{6}+\sqrt{2}}{4} + \frac{\sqrt{2}-\sqrt{6}}{4}i$ is also a solution. [1]

As the equation is cubic, it can be written in the form $(z - a)(z - b)(z - c)$.

$$\left(z - \operatorname{cis}\left(\frac{\pi}{12}\right)\right)\left(z - \operatorname{cis}\left(-\frac{\pi}{12}\right)\right)(z - a) = p^3 - \left(\frac{\sqrt{6}+\sqrt{2}}{2} + a\right)p^2 + \left(\frac{a(\sqrt{6}+\sqrt{2})}{2} + 1\right)p - a [1]$$

Equating coefficients gives $-a = -\sqrt{6} + \sqrt{2}$, so the third solution of the equation is $a = \sqrt{6} - \sqrt{2}$ [1]