

Musicianship & Aural Training for the Secondary School

Deborah Smith

Elite Version

LEVEL
3

Student Book

2nd Edition

DS
MUSIC

3 LEVEL

Student Book - EliteVersion
2nd Edition

Deborah Smith

Published by Deborah Smith Music
Melbourne, Victoria

dsmusic.com.au

Every effort has been made to locate the holders of copyright of the musical examples used in this book. Should an omission have occurred the author would be pleased to be advised and all claims will be settled in good faith.

Printed by Tingleman Pty Ltd, Melbourne, Victoria
www.tingleman.com.au

ISBN 978-0-9775597-4-9

All rights reserved.
No part of this publication may be reproduced in any form or by any means without the prior permission of the author.

The author would like to thank
Jenny Gillan for her endless proofreading, editing, listening, suggestions, ideas, support and friendship,
Andrew Lock for his creative, "on demand" graphics, Lisa Fraser for her beautiful hand drawn solfa handsigns and
David, James and Lara Greenwood for putting up with the author's "creativity" and
their constant love, support and encouragement.

The author acknowledges the amazing teachers, colleagues and students she has learned from, taught and worked with over the years.

Cover design by Andrew Lock

Contents

i Introduction

Rhythm

1	Section 1	Simple Time - Crotchets, Quavers, Minims, Semibreves, Time Signatures, Simple Time Rhythmic Transcription
15	Section 2	Simple Time - Semiquavers, Ties, The Dot, Ostinato, The Dotted Crotchet
29	Section 3	Compound Time, Compound Time Rhythmic Transcription
43	Section 4	Compound Time - Semiquavers, Compound Triple Time
55	Section 5	Two Part Rhythms, Simple Triple Time Signatures, Recognition of Rhythms
69	Section 6	More Semiquavers in Compound Time, Anacrusis
81	Section 7	More Semiquavers in Simple Time, Four Step Rhythm Practice Activity
93	Section 8	Crotchet/Semiquaver Combinations in Compound Time
107	Section 9	The Dotted Quaver in Simple Time, Cut Common Time, Two Part Rhythm
122	Section 10	More Compound Time Signatures, Asymmetrical Time Signatures
133	Section 11	The Triplet, Three Part Rhythm, Changing or Mixed Metres
147	Section 12	Syncopation
159	Section 13	The Dotted Quaver in Compound Time
171	Section 14	The Duplet, A Syncopated Rhythm in Compound Time, Ties in Transcriptions
185	Section 15	More Rhythms in Compound Time
199	Section 16	More Dotted Rhythms in Compound Time

Scales

4	Section 1	The Major Scale, Tonic or Movable <i>do</i> Solfa
19	Section 2	Transposition, Key Signatures and Accidentals
32	Section 3	The Natural Minor Scale and Relative Minor Key Signatures
45	Section 4	The Harmonic Minor Scale
58	Section 5	The Melodic Minor Scale, Visual Key Recognition (Part 1)
72	Section 6	Diatonic & Chromatic Scales
83	Section 7	Aural Tonality Recognition (Parts A and B)
96	Section 8	The Chromatic Scale
110	Section 9	The Pentatonic Scales
125	Section 10	The Blues Scale
137	Section 11	Modes, Ionian Mode, Aeolian Mode, Mixolydian Mode
150	Section 12	Visual Key Recognition (Part 2)
162	Section 13	Aural Tonality Recognition (Part C)
174	Section 14	The Dorian Mode, The Lydian Mode
188	Section 15	Key Recognition of a Scale without a Key Signature
202	Section 16	Other Modes: Phrygian Mode, Locrian Mode

Intervals

6	Section 1	Major, Perfect & Minor Intervals, Intervals within Scales
22	Section 2	Identifying Intervals, Writing Intervals, Inversions of Intervals, Visual Interval Recognition in a Melody
34	Section 3	Diminished Intervals, Augmented Intervals, Interval Alteration Rule, Intervals within the Natural Minor Scale, Aural Interval Recognition in a Melody
47	Section 4	Enharmonic Intervals, Compound Intervals, Intervals within the Harmonic Minor Scale
62	Section 5	Ascending & Descending Perfect & Augmented 4ths, Intervals within the Melodic Minor Scale
74	Section 6	Diatonic and Chromatic Intervals
85	Section 7	Revision
99	Section 8	Intervals within the Chromatic Scale, 3rds in a Major Scale, Interval Lines
112	Section 9	Intervals within the Pentatonic Scales
126	Section 10	Intervals within the Blues Scale
139	Section 11	Intervals within the Mixolydian Mode
152	Section 12	Revision
164	Section 13	Revision
177	Section 14	Revision
190	Section 15	Revision
204	Section 16	Revision

Melody

9	Section 1	Melody, Stem Direction Rules, Melodic Transcription
25	Section 2	Melodic Transcriptions
36	Section 3	Melodic Transcriptions in Minor Keys, Two Part Melodic Transcription
49	Section 4	Minor Melodies
63	Section 5	Melodic Minor Melodies
75	Section 6	Melodic Transcriptions in Melodic Minor Keys
86	Section 7	Three Part Melodic Transcription
101	Section 8	Recognition of Melody
114	Section 9	Pentatonic Melodies
127	Section 10	Blues Melodies
140	Section 11	Mixolydian Melodies
158	Section 12	Melodic Transcriptions
165	Section 13	Melodic Transcriptions
178	Section 14	Dorian Melodies
191	Section 15	Determining Tonality of a Melody without a Key Signature
205	Section 16	Melodic Transcriptions

Chords

12	Section 1	Triads and the Major Triad, Labelling or Naming Triads and Chords
26	Section 2	Intervals in Triads, Other Major Triads in a Major Scale
39	Section 3	Major Triads in Scales
51	Section 4	The Minor Triad
65	Section 5	Revision
77	Section 6	The Diminished Triad
88	Section 7	The Augmented Triad
103	Section 8	Suspension, The Suspended 4th Chord
117	Section 9	Triads in Root Position, Triads in 1st Inversion
129	Section 10	Triads in 2nd Inversion
142	Section 11	7th Chords, The Dominant 7th Chord
154	Section 12	The Major 7th Chord
166	Section 13	The Minor 7th Chord
180	Section 14	The Half Diminished (7th) Chord
194	Section 15	The Diminished 7th Chord
208	Section 16	Revision

Chord Progressions

13	Section 1	Recognition of a Bassline as a Melody, Chord Progression with bassline
27	Section 2	Primary Triads in a Major Key
40	Section 3	Recognition & Transcription of a Chord Progression in a Major Key
53	Section 4	Primary Triads in a Harmonic Minor Key
66	Section 5	Perfect & Plagal Cadences, Transcription of a Chord Progression in a Minor Key
79	Section 6	Root Position Triads in Major Keys
90	Section 7	Root Position Triads in Minor Keys
105	Section 8	Chord Charts for Transcriptions
118	Section 9	Imperfect & Interrupted Cadences
131	Section 10	Revision
144	Section 11	Dominant 7th Chords in Chord Progressions
156	Section 12	Major 7th Chords in Chord Progressions
168	Section 13	Minor 7th Chords in Chord Progressions
182	Section 14	Half Diminished Chords in Chord Progressions
196	Section 15	Diminished 7th Chords in Chord Progressions
210	Section 16	Revision

Appendices

213	Appendix 1	Solfa Names, Handsigns, Letter Names
214	Appendix 2	Key Signatures
216	Appendix 4	Tonality Flow Charts
217	Appendix 3	Scale and Chord Tone Ladders

Student Book - Elite Version, Introduction

The Student Book - Elite Version, Interactive PDF

Access the fully interactive PDF (with hyperlinks to all additional material - videos, worksheets, CD tracks etc) as well as digital and online resources by registering your access number on the bottom right hand corner of the title page. To register go to <http://dsmusic.com.au/> and click on the login/register tab.

Icons Linking to Online Resources

Throughout this book you will find icons in the left margins of each page. (In the case of mp3 files for transcriptions (CD tracks) these icons are found towards the right of the page next to each relevant exercise). Clicking on these icons, in the interactive PDF, will open the relevant online file.



CD track/mp3 file

These links are mp3 files of each transcription type exercise. Each excerpt is recorded once and will need to be played as many times as appropriate.



Video

A video teaching every concept in the book (and many for practicing these concepts) can be accessed by clicking these icons.



Sightsinging/Sightreading

One of the most important practice activities students can undertake is sightreading - singing in solfa and reading rhythm names are the most valuable activities for improving all aspects of musicianship. This icon links to sightsinging/sightreading material based on the elements being taught.



Audio files

These mp3 files give the audio for musical examples throughout the text.



Information Sheets

These PDF files contain more information about the concepts taught in this text.



Clever Echo

These links are to videos of instant dictation practice activities for rhythm, intervals, melody, chords and chord progressions.



Practice Sheets

Links to documents with practice timetables, checklists, additional activities and ideas.

Section 1 - Rhythm



Simple Time - Crotchets, Quavers, Minims, Semibreves etc



This is a **crotchet** (the English name) or **quarter note** (the American name).
This note lasts for one beat (there is **one sound on a beat**).
Its rhythm name is **ta**.



These are **quavers** or **eighth notes**.

A quaver lasts for half a beat (when in pairs there are **two equal sounds on a beat**).

Its rhythm name is **ti** or **ti-ti** when in pairs.



They look like this when written separately.



Read all the **rhythmic examples** in this book (first using inner hearing, then out loud) in rhythm names while performing the beat (conducting, tapping, walking etc). *Click on the associated sightreading sheet icon: **S** in the left margin, for more sightreading exercises.*

The strokes above each beat in the following Rhythmic Examples show where each beat falls.



Rhythmic Example 1

ta ta ti - ti ta ti - ti ti - ti ta ta

A **crotchet rest** or **quarter note rest** lasts for one beat.

A **quaver or eighth note rest** lasts for half a beat.

A **rest** is a silence and therefore no rhythm name is required.

If needed, the rhythm names: **za** (crotchet rest) and **zi** (quaver rest) can be inner heard.



Rhythmic Example 2

ta ta ti - ti ti ta



Time Signatures

The numbers at the start of pieces of music are called **time signatures**.

When the beat can be divided into two equal parts we call the time signature **simple**.

The top number of a time signature in simple time tells us the **number of beats** per bar and the bottom number of a time signature in simple time tells us the **value** of those **beats**.

If the time signature is , the at the top means there are two beats per bar and the at the bottom means these beats are quarter note or crotchet beats.

Therefore, has two crotchet /quarter note beats per bar. This time signature can be described as **simple duple time**, duple meaning two.

In simple time quavers are usually grouped in pairs using a **beam** (the line that joins the two notes together). This is so the beat is clearly defined.

The time signature $\frac{4}{4}$ has four crotchet /quarter note beats per bar. This time signature can be described as **simple quadruple time**, quadruple meaning four.

$\frac{4}{4}$ is the most common of all time signatures and can be written as $\frac{\text{C}}{4}$ for "Common time".

Quavers can sometimes be grouped in four:  but **never** across the 2nd and 3rd beats of a bar of simple quadruple time.

Rhythmic Example 3

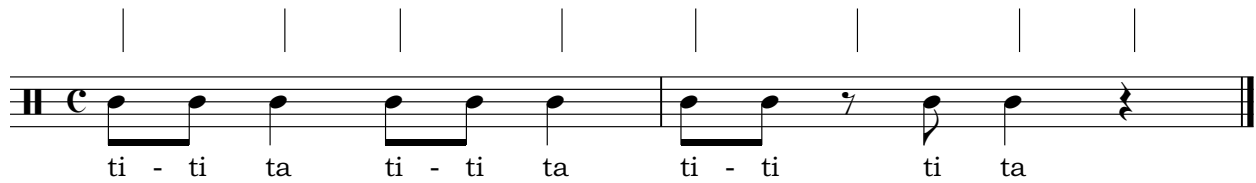

ti - ti ta ti - ti ta ti - ti ti ta

A **minim** or **half note** (to-o) lasts for two beats. A **minim rest** is held for two beats.

A **dotted minim** or **dotted half note** (to-o-o) lasts for three beats. Its equivalent rest is a **dotted minim rest** (a minim rest with a dot).

A **semibreve** or **whole note** (to-o-o-o) lasts for four beats. A whole bar or **semibreve rest** is held for four beats (or the value of a whole bar).

It is the **semibreve** or **whole note** that gives all the notes their American names. For example, a crotchet is worth one quarter of a whole note, therefore its American name is a quarter note.

Rhythmic Example 4

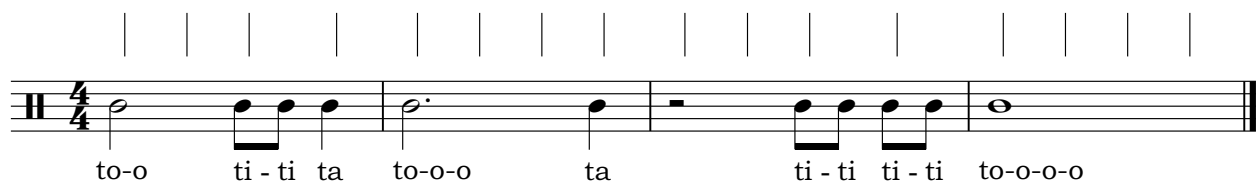

to-o ti - ti ta to-o-o ta ti - ti ti - ti to-o-o-o

Rhythmic Shorthand for Transcriptions

When played a rhythm to write down or transcribe it is helpful to have a way of quickly notating what you hear without having to work out what the rhythms actually are.

This is called **rhythmic shorthand**.

Above each bar to be transcribed write a stroke for each beat. During the first playing listen, follow the rhythm and point to the beat strokes above the empty bars. Then, as you continue listening, mark each beat stroke with a line for each sound you hear.

For example:

- if you hear one sound on a beat (a crotchet) mark the beat stroke with one line: †
- if you hear two sounds on a beat (quavers) mark the beat stroke with two lines: ‡
- if you hear nothing on a beat leave the beat stroke blank as this would be a rest or a long note held over from a previous beat.



Practice Question 1: Simple Time Rhythmic Transcription

- Write out your rhythm set. This is all the rhythmic elements that may be used in a rhythmic transcription exercise. The rhythm set for Practice Question 1 is .
- In the **Rhythmic Transcription** below, two bars have notes written in them and two are empty. There are two beats per bar. Above each bar is a stroke for each beat. During the first playing listen, follow the rhythm given and point to the beat strokes.
- As you continue listening, complete the rhythmic shorthand. Write this onto the staff, using notes, before the final playing.
- Use the final playing to check your rhythm by saying the rhythm names in your head while pointing to the beat strokes. Also check that the correct number of beats is in each bar.

Rhythmic Transcription

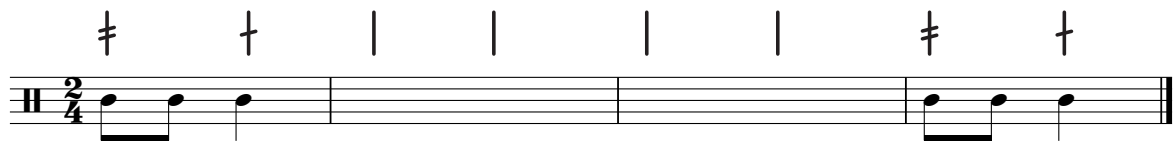

After completing all rhythmic transcriptions read them in rhythm names while **conducting**.



Clever Echo is a very helpful **instant rhythmic dictation** practice activity.

Click on the associated Clever Echo icon:  in the left margin, for the practice video.



A further way to practice rhythm is to compose rhythms using known rhythmic elements and time signatures. Then, read these in rhythm names while conducting.

Worksheet 1

S1 Rhythmic Transcription 1



S1 Rhythmic Transcription 2 (There are three rests in this transcription).

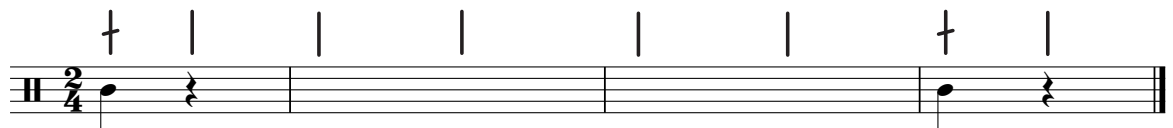

S1 Rhythmic Transcription 3 (There are no rests in this transcription).

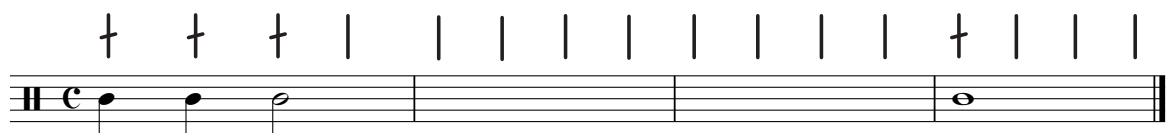

S1 Rhythmic Composition Compose a four bar, simple quadruple rhythm. Perform your rhythm by reading the rhythm names while conducting.

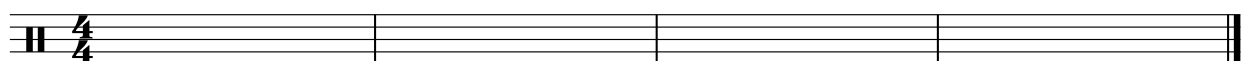

Section 1 - Scales



The Major Scale

The **Major scale** is one of the most common scales in use today. It has been used as a basis for composition since approximately 1600 AD. Scales were originally called modes. Only two modes remain in common usage. The Ionian mode (now known as the **Major scale**) and the Aeolian mode (now known as the **natural minor scale**).



Notes in a scale can be labelled in many ways.

C Major in Scale Degrees

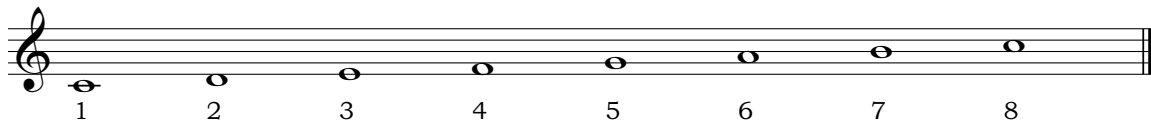

C Major in Tonal or Functional Names

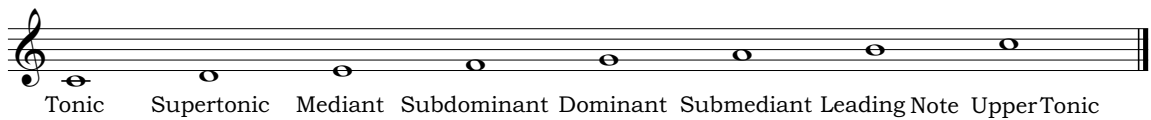

C Major in Letter Names

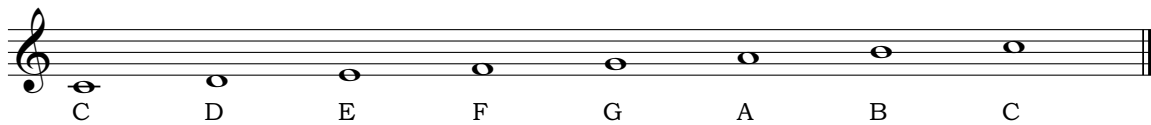

Tonic or Movable *do* Solfa

We can use a **functional note naming system** such as **tonic solfa** (designed specifically for singing), where the tonic note of a Major scale is always *do*.

Click on the associated information sheet icon: in the left margin, for more tonic solfa information.



C Major in Solfa

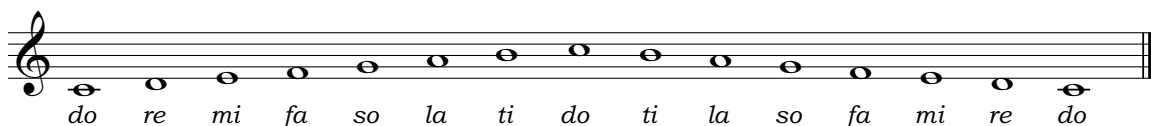

mi

re

do

Handsigns

Each solfa note name has a matching handsign. Solfa handsigns are used to physically show the pitch of the notes in the air. *do* should be placed in front of your stomach and the others are each placed a little higher to show the melodic shape.

See Appendix 1, page 213, for solfa handsigns.

do'

ti

la

so

fa

mi

re

do

All the musical examples given so far have used the **treble** or G clef. This is a sign placed at the start of a piece of music, showing that the music is written for treble (high) voices or instruments. It is called the G clef as it curls around the line where the note G would be. 

This next C Major scale is written out in the **bass** or F clef. This is the sign showing that the music is written for bass (low) voices or instruments. It is called the F clef as the two dots are placed on either side of the line where the note F would be. 



C Major in the Bass Clef

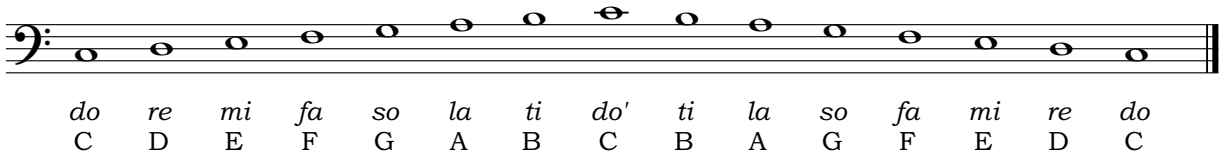

do re mi fa so la ti do' ti la so fa mi re do
C D E F G A B C B A G F E D C



The Grand Staff

The **Grand Staff** usually consists of a treble staff and a bass staff connected by a brace at the beginning.

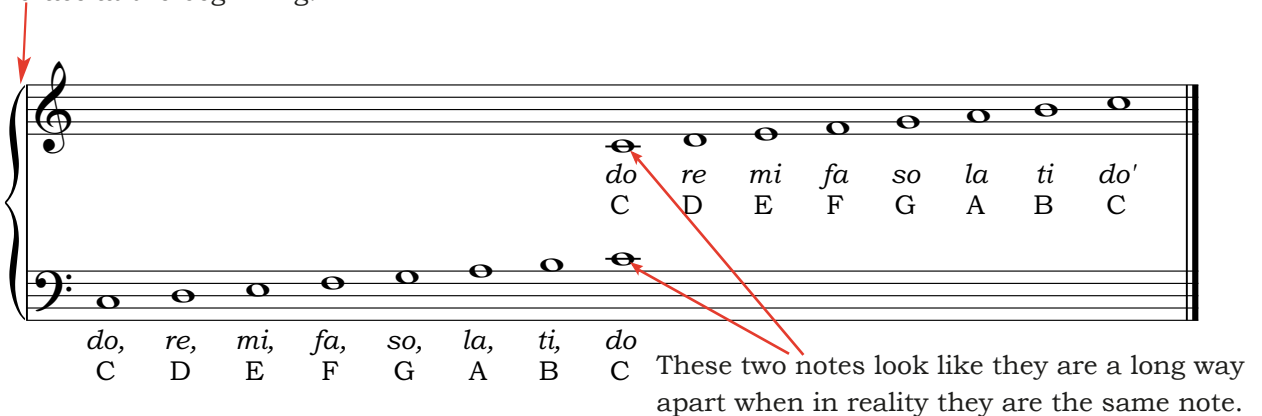

do re mi fa so la ti do'
C D E F G A B C

do, re, mi, fa, so, la, ti, do
C D E F G A B C

These two notes look like they are a long way apart when in reality they are the same note.

We use an **apostrophe** (do') to indicate that a solfa note is in an upper octave. Similarly a **comma** (do,) beside a note's name indicates it is in a lower octave. Notice that solfa names are written in **lowercase** (usually in italics) and letter names are written in **UPPERCASE**.

Worksheet 2

S1 Scales 1 Using semibreves in the treble clef, write one octave (i.e. from middle C up to the next C), ascending and descending, of C Major.

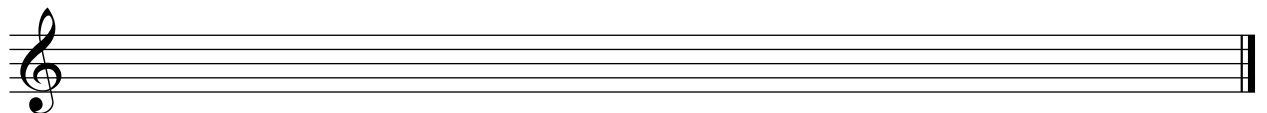

S1 Scales 2 Write the letter names beneath the given C Major scale.

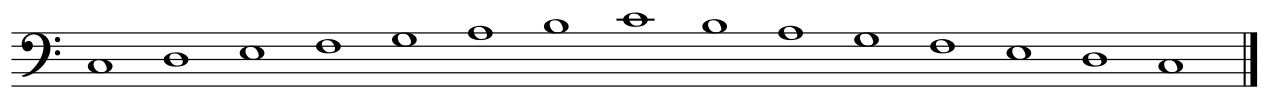

Section 1 - Intervals



Major, Perfect & Minor Intervals & Intervals within Scales

An **interval** is a description of the (inclusive) distance from one note to another. **Major** and **Perfect** intervals are found between the bottom or tonic note of a **Major scale** and other notes within that scale.

A **Major** interval is so named because it is found in the Major scale, however, even though **Perfect** intervals are also found in the Major scale, the name **Perfect** comes from the historical belief that (due to the fact these intervals resonate differently from other intervals) **Perfect** intervals have special meaning to those listening.

Intervals are named according to their **quality** (Major, Perfect etc) and **size** (number).



C up to E is a **Major 3rd** -  a 3rd, as there are 3 note names (C, D and E) involved in this interval and Major, because E is the 3rd note of the C Major scale.

C up to F is a **Perfect 4th** -  a 4th, as there are 4 note names (C, D, E and F) involved in this interval and Perfect, because F is the 4th note of the C Major scale.

Click on the associated information sheet icon:  for more information.

The **lower** note of an interval can be considered the tonic note of that interval.

Major & Perfect Intervals in C Major

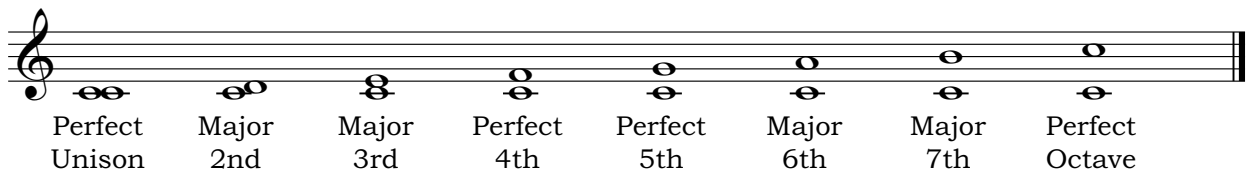

Perfect Unison Major 2nd Major 3rd Perfect 4th Perfect 5th Major 6th Major 7th Perfect Octave



Interval Practice 1

Practise singing all interval exercises (in solfa and in letter names) in all known Major keys.

Ascending & Descending Major & Perfect Intervals

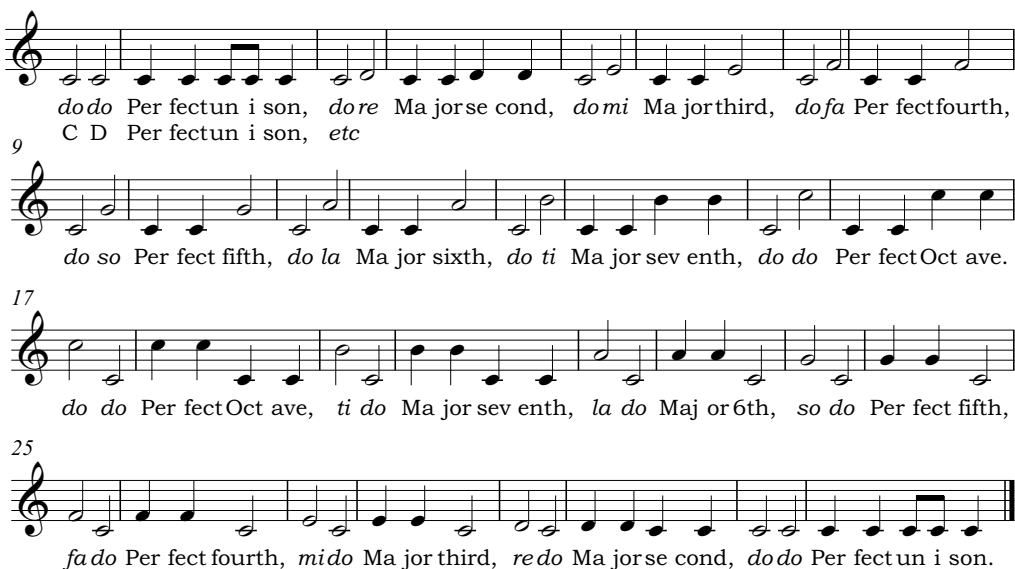

do do Per fectun i son, do re Ma jorse cond, do mi Ma jor third, do fa Per fect fourth,
C D Per fectun i son, etc

do so Per fect fifth, do la Ma jor sixth, do ti Ma jor sev enth, do do Per fect Oct ave.

do do Per fect Oct ave, ti do Ma jor sev enth, la do Maj or 6th, so do Per fect fifth,

fa do Per fect fourth, mi do Ma jor third, re do Ma jorse cond, do do Per fect un i son.

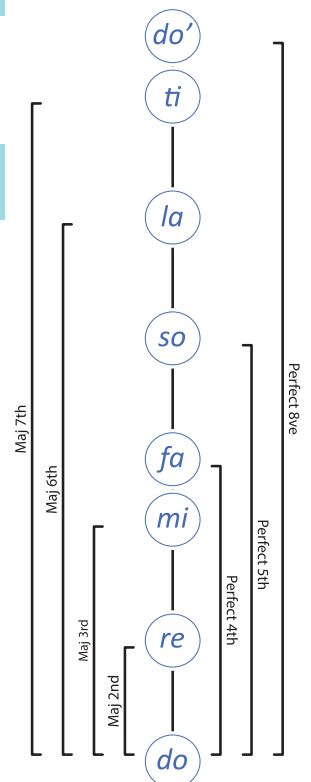

do'

ti

la

so

fa

mi

re

do

Maj 7th

Maj 6th

Maj 3rd

Maj 2nd

Perfect 8ve

Perfect 5th

Perfect 4th

I

Minor intervals are found by taking a Major interval and making it one semitone smaller.

W



C up to E is a Major 3rd (as both these notes are found in C Major) therefore C to Eb is a minor 3rd as the top note is lowered one semitone, making the Major interval one semitone smaller.

A **semitone** is the interval between any note and the next closest or adjacent note.

A **tone** is the interval made up of, or equivalent to, two semitones.

I

A **sharp: #** is a note one semitone above (to the right of) a white note (usually a black note) on the keyboard.

A **flat: b** is a note one semitone below (to the left of) a white note (usually a black note) on the keyboard.

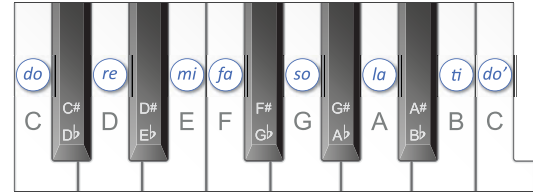

See the related information sheets for more interval information.

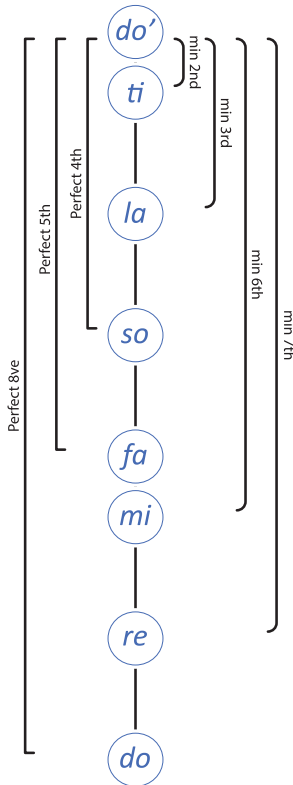

Interval Practice 2

The easiest way to practice all minor and Perfect intervals is by keeping the top *do'* the same and changing the bottom note of each interval.

Ascending & Descending Minor & Perfect Intervals

Intervals within Scales

A scale's specific **interval pattern** will determine the way that particular scale will sound. We show where the **minor 2nds** or **semitones** occur in scales by using slurs.

Intervals within C Major

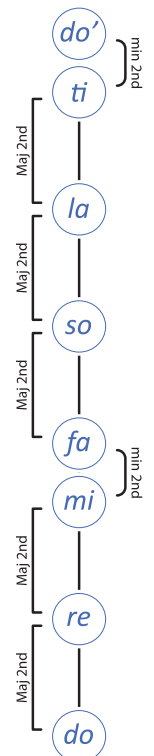

Interval Practice 3

Practise singing all interval pattern exercises (in solfa and in letter names) using both terminologies (i.e. tone and Major 2nd). Practising this exercise (top of next page) will help you to recognise the sound of an interval when asked to determine its number and quality.

C Major Interval Pattern

do re Ma jor se cond, re mi Ma jor se cond, mi fa mi nor se cond, fa so

8
Ma jor se cond, so la Ma jor se cond, la ti Ma jor se cond, ti do mi nor se cond.

15
do ti mi nor se cond, ti la Ma jor se cond, la so Ma jor se cond, so fa

22
Ma jor se cond, fa mi mi nor se cond, mi re Ma jor se cond, re do Ma jor se cond.

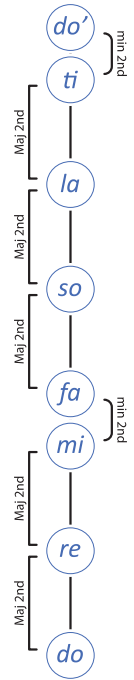

Worksheet 3

S1 Intervals 1 Name these intervals. The first has been done for you. (Note that the bottom note is always C and the top notes are all found in the C Major scale).

Major 3rd

S1 Intervals 2 Name these intervals.

Perfect 5th

S1 Intervals 3 Name these intervals.

Perfect 4th

S1 Intervals 4 Name these intervals.

Perfect 5th

S1 Intervals 5 Ascending intervals will be played twice each. They will be one of the following: a Major 2nd, Major 3rd, Major 7th, Perfect 5th or a Perfect 8ve. Name the intervals you hear.

Click on the icon at the top of this worksheet for interval recognition clever echo video.

1. _____
2. _____
3. _____
4. _____
5. _____
6. _____

Section 1 - Melody

 Sightread the following melodies: "Lara's Song" and "James's Song" by first saying the rhythm names of the notes while tapping or conducting the beat, then by singing the notes in solfa and letter names.

 Use this process for all scales, interval exercises, melodic examples and completed transcription exercises throughout this book.

Click on the associated sightreading sheet icon:  for more sightreading exercises.

Lara's Song

Smith

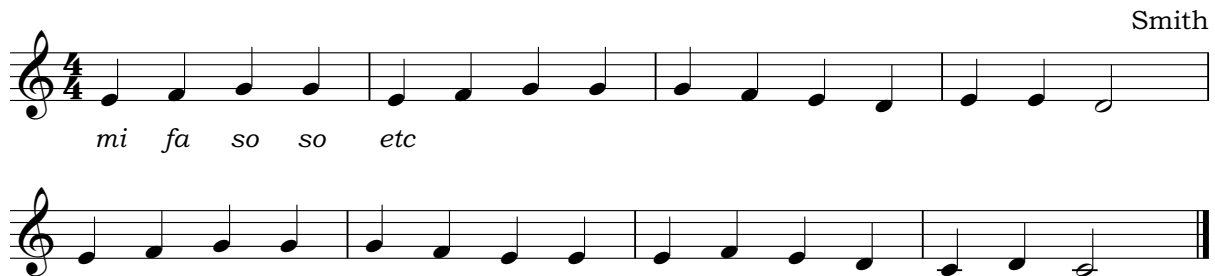

When a melody such as "Lara's Song" has been written using only notes from the scale of C Major (and ends on C) we say that this composition is in the **key of C Major**.

James's Song

Smith



Stem Direction Rules

When notes are written on a staff, there are rules to follow for the direction of the stems.

If the note is above the middle line of the staff  then the stem must go down and is attached to the front of the notehead.

If the note is below the middle line  the stem must go up and is attached to the back of the notehead.

If the note is on the middle line  the stem may go up or down.

The stem rule: Stems are written **down before** or **up after**.

Melodic Transcription

A **Melodic Transcription** is a dictation exercise where a melody (with or without accompanying parts) is played several times so that it may be notated in solfa or on the staff.

A shorthand version of solfa omits the last letter of each solfa name. For example **mi** becomes **m**.



Practice Question 2: Melodic Transcription

1. Study the melodic transcription below. The melody to be transcribed is in C Major, therefore, write the C Major scale on the treble staff given with solfa and letter names beneath each note:

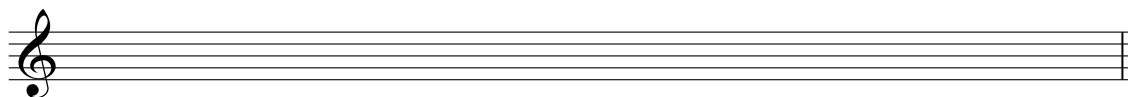

This is your **transcription scale** and needs to be written for **EVERY** melodic transcription.

2. Sing this scale in solfa and letter names.
3. The melody for Practice Question 2 will be played several times. Before it begins, note the rhythm of the melody given above the staff. The solfa of the starting note is given under the first crotchet of this rhythm.
4. The first time you hear the melody, listen and point to the rhythm above the staff. If you **recognise** any notes (such as the tonic: *do* or the dominant: *so*) write the solfa of these notes under the rhythm where you heard them. You may remember the solfa of the last few notes as these will remain in your internal memory.
5. Use further playings of the melody to continue writing the solfa you hear under the rhythm. When you are (fairly) sure your solfa is correct write this as notes on the staff. (Do not leave this until the end as looking at the notes written on the staff can help you find mistakes).
6. Have the notes of this melody on the staff before the final playing. Use the final playing to check your completed melody by singing it in solfa in your head as you listen.

Melodic Transcription

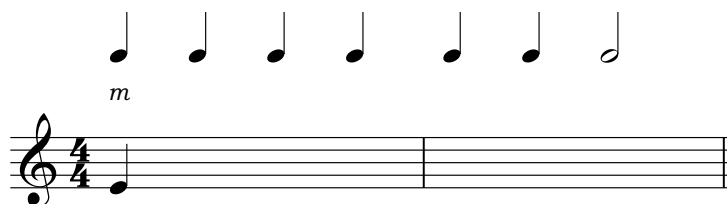

1/06

Some melodic transcription exercises will **not** provide the rhythm of the melody. In these exercises, first complete the rhythmic shorthand (as if completing a rhythmic transcription exercise) then add the solfa beneath the strokes you have made for each note before writing these notes onto the staff.

As with all completed and corrected transcriptions, sing through in rhythm names, solfa with handsigns and in letter names.



Clever Echo is a practical **instant melodic dictation** practice activity.

Click on the Clever Echo icon: in the left margin, for the practice video.



A further way to practice melody is to compose melodies using known melodic elements and scale forms. Then sing these in solfa, with handsigns and in letter names.

Worksheet 4

Transcription Scale for **S1 Melodic Transcriptions 1, 2 and 3.**

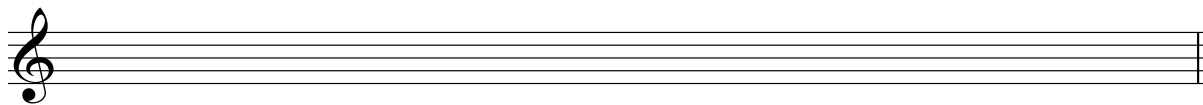

S1 Melodic Transcription 1

1/07

S1 Melodic Transcription 2

1/08

S1 Melodic Transcription 3

1/09

W

S1 Melodic Composition Create a simple C Major melody by writing the rhythm on the top staff, the solfa underneath this rhythm and then transferring this onto the treble staff below. Sing in solfa and letter names once you have finished.

3

Section 1 - Chords



Triads and the Major Triad

Triads are **chords** made up of three different notes and can be built on any scale degree.

A **root position triad** (with the **root note** – the note on which the triad has been built – on the bottom) will have a root note, a note a third higher and a note a fifth higher than the root note.

A **Major triad** (in root position) is made up of a root note, the note a **Major 3rd** higher and the note a **Perfect 5th** above the root note.

Intervals within the C Major Triad

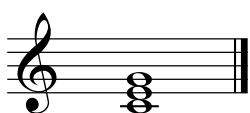

C to E is a Major 3rd (as it is the 3rd note of the C Major scale) and E to G is a minor 3rd (E to G is a semitone smaller than the Major 3rd due to the semitone between E and F - *mi* and *fa*).

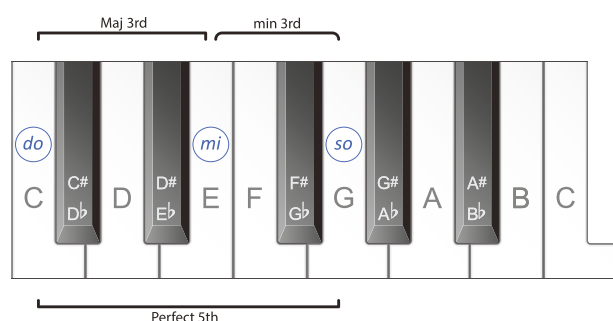

Therefore, the bottom interval in a Major Triad is a Major 3rd and the top interval is a minor 3rd.

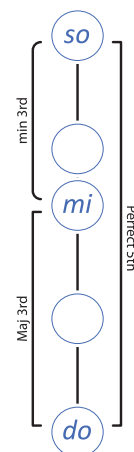

Labelling or Naming Triads and Chords



Chord Name: This naming system uses the letter name of the root note the triad is built on and the quality of the triad. This triad can be called the **C Major triad** (it is the Major triad built on C).

Roman Numeral: This triad is **Chord I** in C Major. (I is UPPERCASE meaning Major and I is the Roman numeral for the number 1 - it is the triad built on the 1st scale degree of the C Major scale).

Figures: Small numbers can be added to show the intervals between the bottom note and other notes within a triad or chord. This triad is I^{3} indicating that there is a 5th and a 3rd above the root note.

Tonal or Functional Name: This is the tonal or functional name of the root note the triad is built on within a particular scale. Triads can be **diatonic**, or belong, to a particular scale. This triad can be called the **C Major tonic triad** (all the notes in this triad belong to the C Major scale and it is built on the tonic of C Major).



Triad and Chord Practice

Triads and chords can be practiced melodically by singing the notes that create the chord in solfa, with handsigns.



Worksheet 5

S1 Chords 1 Complete these sentences.

The bottom 3rd in a Major triad is a _____ 3rd. The top 3rd in a Major triad is a _____ 3rd.

The interval from the lowest note to the highest note in a Major triad is a _____.

Section 1 - Chord Progressions



Recognition of a Bassline as a Melody

Recognising the **bassline** (lowest note of each chord) of a **chord progression** (a set of chords played one after another) is a necessary first step to recognising the whole chord.

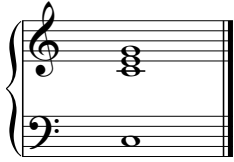

If we take the C Major tonic triad, double the root (lowest) note and write this in the bass clef we have created a bassline to go with this chord.



Chord Progression with bassline



Listen to this chord progression and sing the bassline.

Note that while the top part does not always have the notes in a $\frac{5}{3}$ or root position, the **lowest** note, in the bass clef, of each triad is the **root** note therefore the triad **is** a root position triad.

It is the bass or lowest note of a chord, often shown in the bass clef, that gives a chord its position e.g. root position.

do/C re/D fa/F so/G do/C



Practise all chord progression examples and all completed and corrected transcription exercises by singing the bassline in solfa and letter names.



Worksheet 6

Three chord progressions in the key of C Major will be played several times each. Write the solfa or letter names of the bassline for each chord played.

Click on the Clever Echo icon:  for the practice video.

S1 Recognition of a Bassline 1

	Chord 1	Chord 2	Chord 3	Chord 4
Bass note	do/C			

1/10

S1 Recognition of a Bassline 2

	Chord 1	Chord 2	Chord 3	Chord 4
Bass note	do/C			

1/11

S1 Recognition of a Bassline 3

	Chord 1	Chord 2	Chord 3	Chord 4
Bass note	do/C			

1/12

Section 1 - Revision & Practice Questions

Theory Revision

W

S1 Rhythm Add barlines to this rhythm.



W

S1 Scales Using half notes in the treble clef, write one octave, descending THEN ascending, of C Major. Write the solfa AND letter names beneath each note.



W

S1 Intervals Name these intervals.

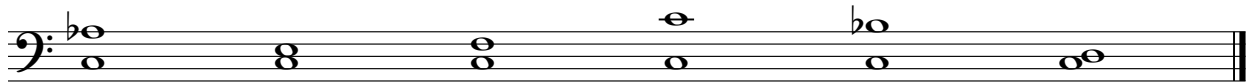

W

S1 Melody Complete this C Major melodic composition then sing it in solfa with handsigns.



P

Musicianship Practice

PRACTICE ACTIVITIES Click on the Practice icon: **P** in the left margin, for more information about the practice tasks below, including video links, worksheets etc

- Read simple time rhythms in rhythm names while conducting the beat
- Write simple time rhythms in shorthand
- Compose simple time rhythms then read in rhythm names while conducting the beat
- Sing the Major scale in solfa with handsigns
- Sing the C Major scale in letter names
- Write the C Major scale in treble or bass clef
- Sing all Major & Perfect Intervals in solfa with handsigns
- Sing all minor & Perfect Intervals in solfa with handsigns
- Sing C Major naming the consecutive intervals in solfa with handsigns
- Sing C Major melodies in solfa with handsigns
- Compose C Major melodies then sing in solfa with handsigns
- Sing the C Major triad in solfa with handsigns
- Sing basslines in solfa with handsigns

Section 2 - Rhythm



Simple Time - Semiquavers



These are **semiquavers** (the English name) or **sixteenth notes** (the American name). When grouped in four they last for one beat (there are **four** equal sounds on a beat). Its rhythm name is **tika-tika**.



This is an individual **semiquaver** which lasts for one quarter of a beat.



Rhythmic Example 5

ti - ka - ti - ka ti - ti ti - ka - ti - ka ta etc



Rhythmic Example 6



A **semiquaver** or **sixteenth note rest** lasts for one quarter of a beat.



Rhythmic Example 7



Ties



A **tie** is a curved line that joins the rhythmic values of one note to the next. (In a melody, these two notes must be the same pitch).

For example, if two crotchets are tied together:  the first crotchet is played and then held for its own value, plus the value of the note it is tied to i.e. two beats. In rhythm names we would say "ta-a".

For example this rhythm written with ties:

could be written like this without ties:



Rhythmic Example 11

Tam-ti written
with ties:



This rhythm is often used reversed: (ti-tam) and can sound like:

Read Rhythmic Examples 12 and 13 with this ostinato:

taking note of where, in the ostinato,
the second note of this new rhythm falls.

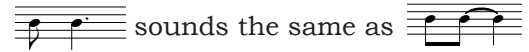

Rhythmic Example 12

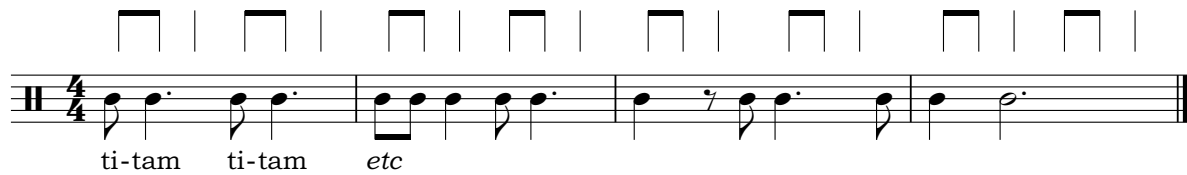

Rhythmic Example 13



Worksheet 7

The rhythmic shorthand will only be shown for new rhythms the first time it is used in a rhythmic transcription exercise. Write a rhythm set and shorthand for each of these transcriptions. There are no rests in these transcriptions.

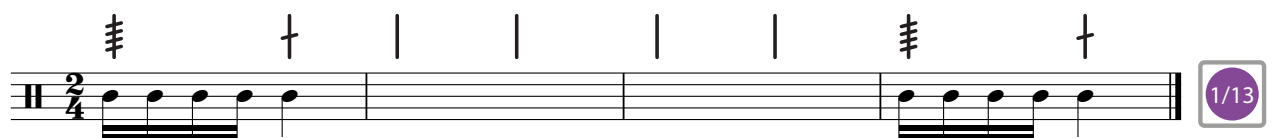
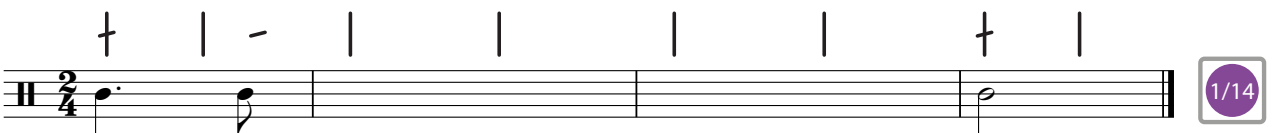
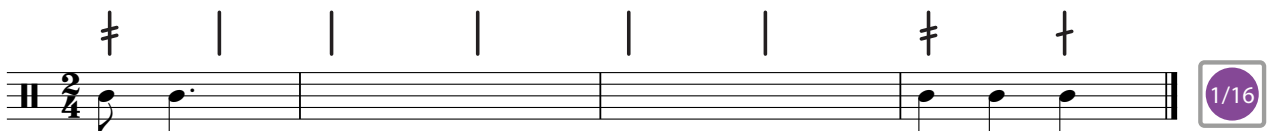
S2 Rhythmic Transcription 1**S2 Rhythmic Transcription 2****S2 Rhythmic Transcription 3****S2 Rhythmic Transcription 4**

Section 2 - Scales



The Major Scale Interval Pattern

In C Major there are Major 2nds (tones) between each pair of notes **except** *mi* and *fa* (E and F) and *ti* and *do'* (B and C) as marked by the slurs in the following scale. These pairs of notes form minor 2nds (semitones). The handsigns for *fa* (pointing down) and *ti* (pointing up) indicate where the semitones fall.

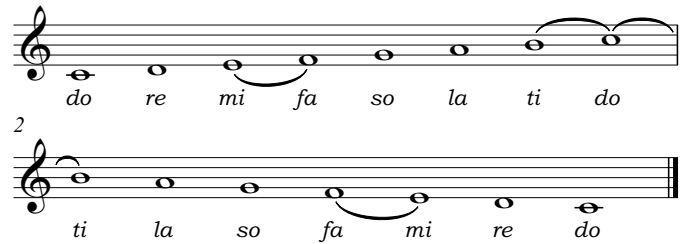
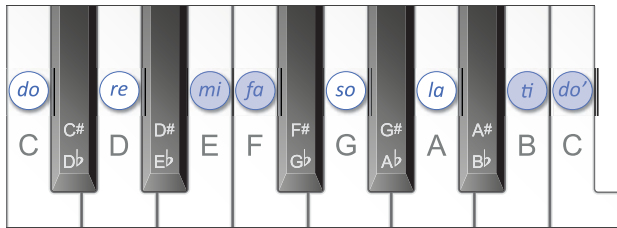

Transposition

All scales can be **transposed** (meaning moved into a new key) to begin on any new note by keeping the original interval pattern of that scale the same.

If you take the interval pattern of **C Major** (see blue solfa below) and begin on **G** (see red solfa below) you will see that the 7th note: *ti*, falls on a black note (F#). This keeps the pattern of intervals the same as in the original Major scale.

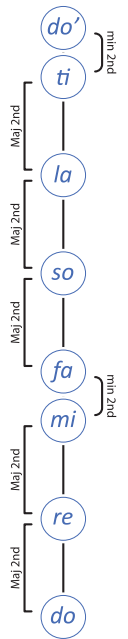
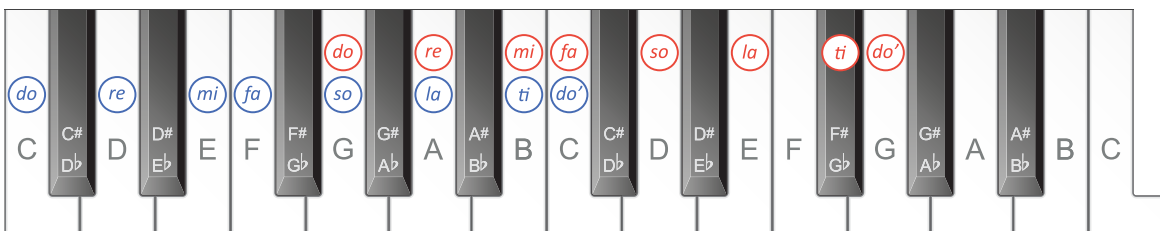

G Major Scale

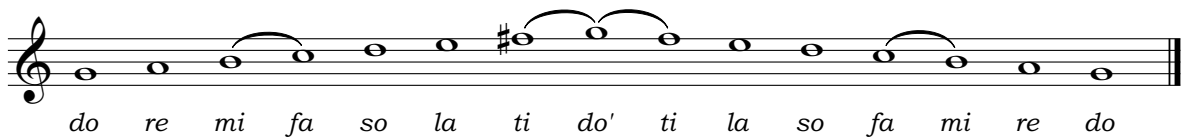

Key Signatures and Accidentals

To avoid having to write a sharp sign in front of every F in a piece of music based on the scale of G Major, we place the sharp required after the clef at the beginning of each line of music. This is called the **key signature**. A sharp or flat that is **not** found in the key signature is called an **accidental**. An accidental lasts for a full bar (until the next barline) or until it is cancelled out by another accidental (a sharp, a flat or a natural: ♮).

G Major Scale with a Key Signature

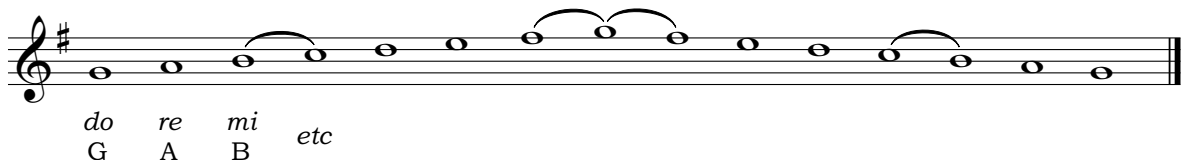

To write **F Major** (see green solfa below), follow the interval pattern of the **Major scale** (see blue solfa below). You will see that the 4th note: *fa*, falls on a black note (**B \flat**).

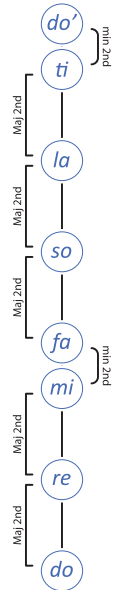
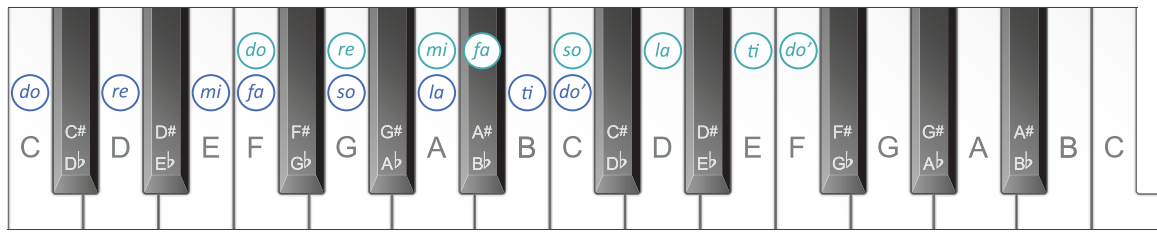

F Major Scale with a Key Signature

In the same way as scales can be transposed so can melodies.



This next example is "Lara's Song" from page 9 transposed from C Major into the key of F Major. Sing the F Major scale then sing this version of the song in solfa and letter names. (**B \flat** will be sung as "Bess". See Appendix 1 or click on for all solfa and letter name alterations).



Lara's Song - F Major version



Major Key Signatures

Every Major scale has its own key signature:

Click on the associated information sheet icon for key signatures in the bass clef.

Sharp Keys

(C Major:)

G Major:

D Major:

A Major:

E Major:

B Major:

F# Major:

C# Major:

Flat Keys

(C Major:)

F Major:

B \flat Major:

E \flat Major:

A \flat Major:

D \flat Major:

G \flat Major:

C \flat Major:



The Order of Sharps and Flats in a Key Signature



The first sharp in a key signature containing sharps is always F and each additional sharp is a 5th above: F, C, G, D, A, E and B. The order of flats in a key signature is the reverse of the order of sharps (or beginning on B and going down a 5th): B, E, A, D, G, C and F.



Finding a Key from a Key Signature



The last sharp in a Major key's key signature (with sharps) is the leading or 7th note of that key. For example, if there are three sharps in the key signature then the last sharp will be G \sharp . This is the leading note of A. Therefore the Major scale with three sharps in its key signature is A Major.

Hint: When sharps you see, the last is *ti* (G \sharp is *ti* in A Major).

The name of the Major key with flats in the key signature will be the second last flat of the key signature. For example, if the key signature has three flats then the second last flat will be E \flat . Therefore E \flat Major has three flats in its key signature.

Hint: When flats there are, the last is *fa* (the last flat in the key signature is A \flat . This is *fa* in E \flat Major).



Worksheet 8

S2 Scales 1 Write the ascending and descending Major scale that begins on, and uses the note value of (a crotchet), the given tonic note. Use a key signature, write the solfa beneath each note and use slurs to show the semitones.

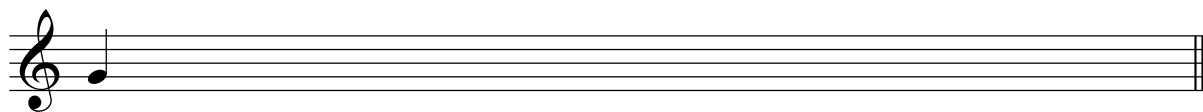

S2 Scales 2 Write the ascending and descending Major scale that begins on the given tonic note. Use a key signature.

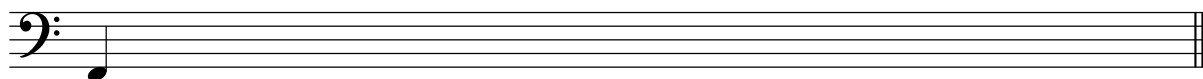

S2 Scales 3 Using a key signature, write two ascending octaves of G Major in crotchets.

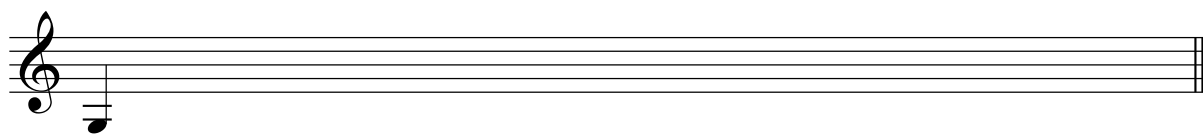

S2 Scales 4 Write the ascending Major scale that begins on the given tonic note in the bass clef. Use whole notes and identify the interval between each consecutive pair of notes.

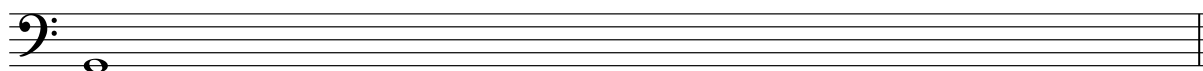

S2 Scales 5 Write the key signatures belonging to the following keys.



D Major

F Major

E \flat Major

G Major

C Major

A Major

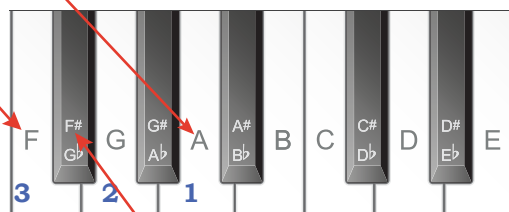
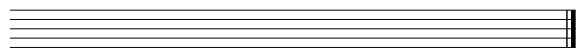
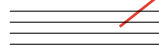
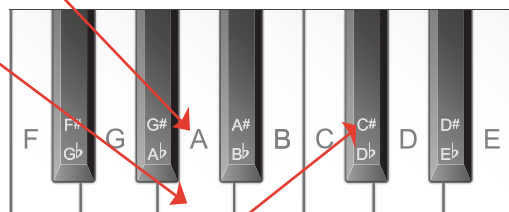
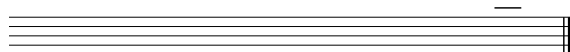
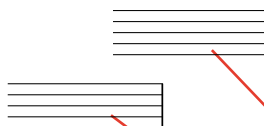
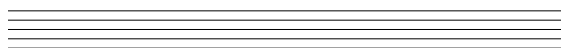
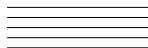



Inversions of Intervals

Knowing how to invert intervals can also be helpful when working out and writing intervals.

To invert an interval you turn it upside down.

In this example A up to C \sharp has been inverted to C \sharp up to A.

So a Major interval has become a minor interval and a 3rd has become a 6th.



Interval: Major 3rd Inversion: minor 6th

When you invert an interval:

- Major becomes minor,
- minor becomes Major,
- Perfect remains Perfect and
- the sum of the numbers that make up the two intervals equals nine
e.g. Major **3rd** becomes a minor **6th** = **3 + 6 = 9**

(For future reference: diminished intervals becomes Augmented and Augmented intervals becomes diminished - see page 35 for explanations of diminished and Augmented intervals).

Knowledge of inversions of intervals can be useful if the lowest note of an interval is the tonic of a scale with a difficult key signature.

For example, to name this interval:

it may be easier to work out the quality and name of its inversion first:

The third note of E \flat Major is G natural, which would be a Major 3rd.

As the note written is a G \flat , this is one semitone smaller, therefore it is a minor third.

If you invert this interval (to give the name of the original interval) minor becomes Major and the numbers add up to 9 therefore G \flat up to E \flat is a Major 6th.



Interval: Major 6th Inversion: minor 3rd

Practice Question 3: Visual Interval Recognition in a Melody

Each pair of notes in a melody creates an interval. To name an interval, note that the quality of an interval is defined by the **bottom** note.

When working out intervals between pairs of notes in a melody, consider each pair of notes out of context (i.e. out of the melody) being sure to note if the key signature affects either note.

1. In the "Visual Interval Recognition in a Melody" example below the first pair of bracketed notes is B \flat (there is a B \flat and an E \flat in the key signature) up to D. As B \flat is the bottom or lower note, we need to consider the B \flat Major scale. As D is the 3rd note of the B \flat Major scale this interval is a Major 3rd.
2. The second bracketed pair of notes (B \flat down to F) is a Perfect 4th because B \flat is the 4th note of the F Major scale.

Visual Interval Recognition in a Melody





Worksheet 9

S2 Intervals 1 Name these intervals. The first has been done for you. (Note that the bottom note changes for each interval).

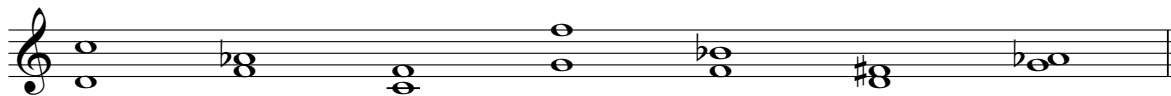

minor 7th

S2 Intervals 2 Write these intervals above the given notes.

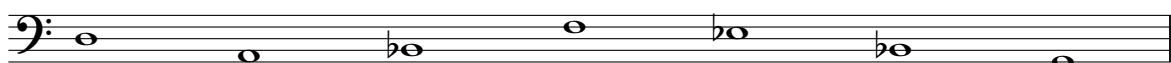

minor 3rd Perfect 4th minor 7th Major 2nd Perfect 5th minor 2nd minor 6th

S2 Intervals 3 Write these intervals below the given notes.



Perfect 4th Perfect 5th minor 3rd Major 6th Perfect 8ve Major 2nd minor 7th

S2 Intervals 4 Name the inversions of the following intervals.

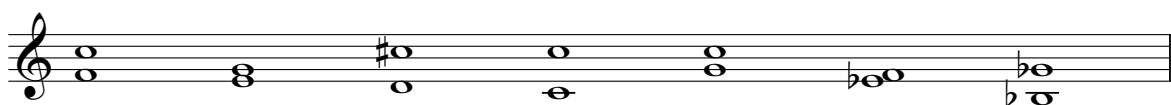

Perfect 4th

S2 Intervals 5 Identify the three bracketed intervals in the following melody. Write your answers (quality and number) beneath the brackets.



S2 Intervals 6 Identify the three bracketed intervals in the following melody. Write your answers (quality and number) beneath the brackets.



S2 Intervals 7 Ascending intervals will be played twice each. They will be one of the following: a minor 2nd, minor 3rd, minor 7th, Perfect 4th or a Perfect 8ve. Name the intervals you hear.

1. 2. 3. 4. 5. 6.

Section 2 - Melody

S

Worksheet 10

CE

See page 10 for more information about writing transcription scales.

S2 Melodic Transcription 1 Transcription Scale:

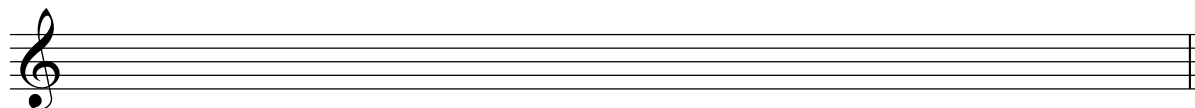

S2 Melodic Transcription 1

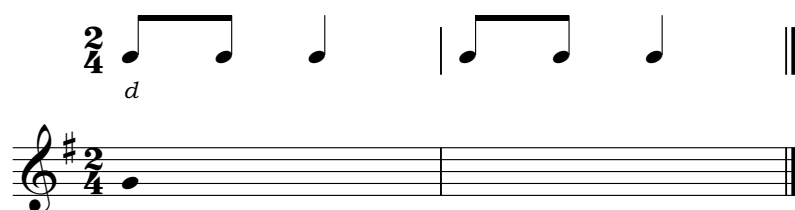

1/22

S2 Melodic Transcription 2 Transcription Scale:

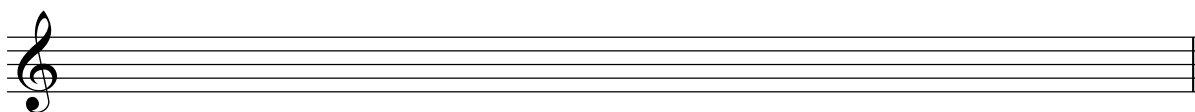

S2 Melodic Transcription 2



1/23

S2 Melodic Transcription 3 Transcription Scale:

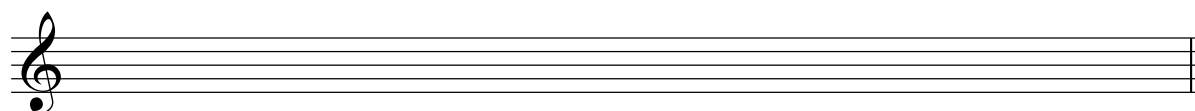

S2 Melodic Transcription 3

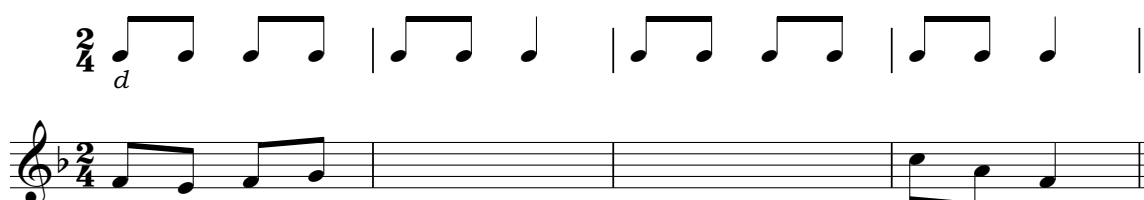

1/24

Section 2 - Chords



Intervals in Triads

The Major triad can be described as having a Major 3rd at the bottom (in this example, between C and E) and a minor 3rd at the top (between E and G).

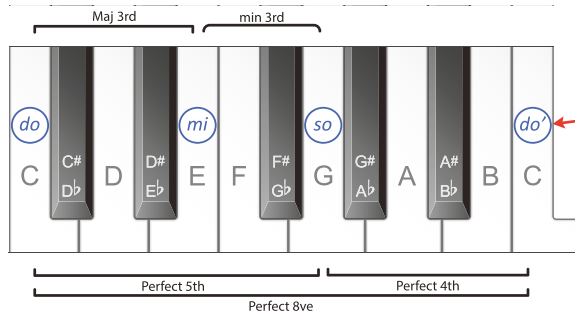

Often, when writing chords for use in a composition, a composer will "double the root" one octave higher.

In a Major triad, this creates another interval between the root note and the top note of a Perfect Octave and a Perfect 4th between *so* and new note, *do'*. These intervals can be seen in the second line of "Intervals in a (C) Major Triad".

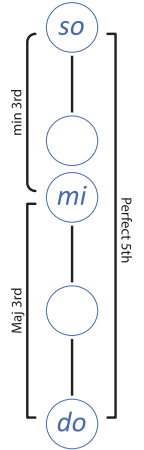

Intervals in a (C) Major Triad

Other Major Triads in a Major Scale

Major triads can be built on the 1st, 4th and 5th scale degrees of a Major scale:

s	d'	r'
m	l	t
d	f	s
I	IV	V

Worksheet 11

S2 Chords 1 Write Major triads above the given notes.

S2 Chords 2 Write Major triads above the given notes.

Section 2 - Chord Progressions



Primary Triads in a Major Key

The triads built on the **tonic** (I), **subdominant** (IV) and **dominant** (V) notes of a scale are known as the **primary triads**. These are **Major** triads, as indicated by the CAPITAL Roman numerals.

These are the three primary triads of C Major:

I IV V

C Major Primary Triads

d m s m d I, f l d' l f IV, s t r' t s V



Worksheet 12

S2 Chord Progressions 1 Using a key signature, write the three primary triads of F Major. Label them with Roman numerals.

S2 Chord Progressions 2 Write the three primary triads belonging to the Major key with the given key signature. Label them with Roman numerals.



S2 Recognition of a Bassline 1 A chord progression, using only the primary triads, will be played several times. The given bass note of the first chord is the tonic. Write the solfa and letter names of the bassline for each chord.

	Chord 1	Chord 2	Chord 3	Chord 4
Bass note	<i>do/C</i>			

1/25



S2 Recognition of a Bassline 2 A chord progression, using only the primary triads, will be played several times. The given bass note of the first chord is the tonic. Write the solfa and letter names of the bassline for each chord played.

	Chord 1	Chord 2	Chord 3	Chord 4
Bass note	<i>do/F</i>			

1/26

Section 2 - Revision & Practice Questions

Theory Revision

W

S2 Key Signatures Write the key signatures belonging to the following keys.

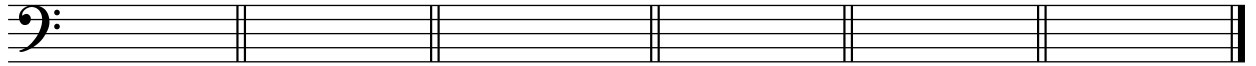

B \flat Major E Major A \flat Major B Major D \flat Major A Major

W

S2 Scales Using semibreves in the bass clef, write one octave, ascending THEN descending, of D Major using a key signature. Write the solfa AND letter names beneath each note.

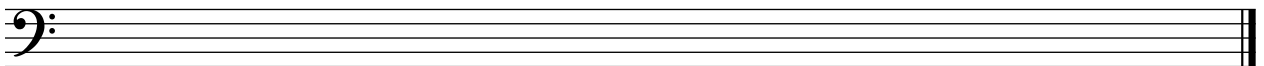

W

S2 Melody Create a simple F Major melody by writing the rhythm on the top rhythmic staff, the solfa underneath this rhythm and then transferring this onto the bass staff below, using a key signature. Sing in solfa and letter names once you have finished.

P

Musicianship Practice

PRACTICE ACTIVITIES Click on the Practice icon: **P** in the left margin, for more information about the practice tasks below, including video links, worksheets etc

- Read simple time rhythms in rhythm names while conducting the beat
- Write simple time rhythms in shorthand
- Compose simple time rhythms then read in rhythm names while conducting the beat
- Sing the Major scale in solfa with handsigns
- Sing the Major scale in solfa with handsigns, inner hearing every second note
- Sing the F and G Major scale in letter names
- Sing all Major & Perfect Intervals in solfa with handsigns
- Sing all minor & Perfect Intervals in solfa with handsigns
- Sing the Major scale, naming the consecutive intervals, in solfa with handsigns
- Sing C Major melodies in solfa with handsigns
- Compose Major melodies then sing in solfa with handsigns
- Sing the Major triad naming the consecutive intervals in solfa with handsigns
- Sing basslines in solfa with handsigns

Section 3 - Rhythm



Compound Time - $\frac{6}{8}$ $\frac{12}{8}$ Quavers and Dotted Crotchets

Simple time can be defined as a time signature where the value of the beat is a crotchet that can be divided equally into two quavers. We call these quavers: **pulses**.

Simple time:
Beat Value: Crotchet
Pulse division: two quavers



Compound time can be defined as a time signature where the value of the beat is a dotted crotchet that can be divided into equally into three pulses.

Compound time:
Beat Value: Dotted crotchet
Pulse division: three quavers



In **compound time**, the **top number** of the time signature tells us the **number of pulses** per bar and the **bottom number** of a time signature tells us the **value** of those **pulses**.

As it is customary to refer to "beats per bar" rather than "pulses per bar" we say there are two **dotted crotchet** or **dotted quarter note beats** per bar.



Rhythmic Example 14

Dotted crotchet beats: | . | . |

Quaver pulses: $\frac{6}{8}$

In **Rhythmic Example 14**, the time signature is $\frac{6}{8}$

The $\frac{6}{8}$ at the top means there are six pulses per bar and the $\frac{8}{8}$ at the bottom means these pulses are eighth note or quaver pulses.

Therefore, $\frac{6}{8}$ has six quaver pulses per bar and two dotted crotchet beats per bar.

This time signature can be described as **compound duple time**.

In compound time the quavers are usually grouped in threes

In a bar of $\frac{6}{8}$ there can be two groups of three quavers (three equal sounds on a beat).

To find the number of beats in a bar of compound time, divide the top number by three.

A **dotted crotchet** or **dotted quarter note** (tam) lasts for one beat in compound time.
Its equivalent rest: also lasts for one beat in compound time.



A **dotted minim** or **dotted half note** (to-o) lasts for two beats in compound time. =

A **dotted minim rest**: is held for two beats in compound time.



Rhythmic Example 15

$\frac{6}{8}$

12 This is another compound time signature and can be described as **compound quadruple**.
8 This time signature has **four dotted crotchet beats** per bar (and twelve quaver pulses).



Rhythmic Example 16



In compound time there are two common **uneven** rhythms. These are combinations of crotchets and quavers:



We say **ta ti** which is a longer sound (lasting for two pulses) followed by a shorter sound (worth one pulse)



and



We say **ti ta** which is a shorter sound (worth one pulse) followed by a longer sound (lasting for two pulses)

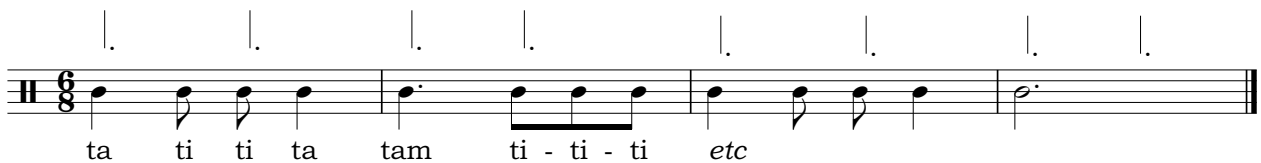

Rhythmic Example 17



A **crotchet**  or its rest  are worth two thirds of a beat or two pulses.

A **quaver**  or its rest  are worth one third of a beat or one pulse.



Rhythmic Example 18



Practice Question 4: Compound Time Rhythmic Transcription

- Write out your rhythm set.

The rhythm set for Practice Question 4 is: 

- In the "Rhythmic Transcription" at the top of the next page, two bars have notes written in them and two are empty. There are six pulses or two beats per bar. Above each bar is a stroke for each pulse. During the first playing listen, follow the rhythm given and point to the pulse or beat strokes (depending on the tempo).

Note that in **compound time** the count in may be in dotted crotchet beats, which will have to be divided into three pulses. (The shorthand has longer strokes for the pulses that fall on a beat).

- During the second playing, make a mark for each sound you hear. For example, if you hear one sound on each pulse (quavers or ti-ti-ti) mark each pulse stroke with one line. If you hear one sound that lasts for three pulses or one full beat, (dotted crotchet or tam) mark the first pulse stroke (on the beat) with one line and leave the next two blank (this sound lasts for three pulses).
- Complete the rhythmic shorthand as you listen. Write the rhythm of the shorthand onto the staff, using notes.
- Use the final playing to check your rhythm by saying the rhythm names in your head while pointing to the pulse/beat strokes. Also check that the correct number of beats is in each bar.

Rhythmic Transcription

A musical staff in 6/8 time. The first bar contains a dotted quarter note followed by three eighth notes. The second bar is empty. The third bar is empty. The fourth bar contains three eighth notes followed by a dotted quarter note. Above the staff are vertical tick marks indicating the rhythm: three ticks in the first bar, three in the second, three in the third, and four in the fourth.

1/27



Worksheet 13

Write a rhythm set and shorthand for each of these transcriptions. There are no rests in these transcriptions.

S3 Rhythmic Transcription 1

A musical staff in 6/8 time. The first bar contains a dotted quarter note followed by three eighth notes. The second bar is empty. The third bar is empty. The fourth bar contains a dotted quarter note followed by an eighth note.

1/28

S3 Rhythmic Transcription 2

An empty musical staff in 12/8 time.

1/29

S3 Rhythmic Transcription 3

A musical staff in 6/8 time. The first bar contains a dotted quarter note followed by three eighth notes. The second bar contains a dotted quarter note followed by an eighth note. The third bar is empty. The fourth bar is empty. Above the staff are vertical tick marks indicating the rhythm: four ticks in the first bar, two in the second, three in the third, and three in the fourth.

1/30

S3 Rhythmic Transcription 4

A musical staff in 6/8 time. The first bar is empty. The second bar is empty. The third bar contains a dotted quarter note followed by an eighth note. The fourth bar contains a dotted quarter note followed by three eighth notes. Above the staff are vertical tick marks indicating the rhythm: three ticks in the first bar, three in the second, four in the third, and four in the fourth.

1/31

S3 Rhythmic Transcription 5

An empty musical staff in 12/8 time.

1/32



S3 Rhythmic Composition Compose four bars of compound duple time.

An empty musical staff in compound duple time (3/4).



S3 Rhythmic Theory Add one note to complete each bar.

A musical staff in 6/8 time. The first bar contains a dotted quarter note. The second bar contains three eighth notes. The third bar contains a dotted quarter note followed by an eighth note. The fourth bar is empty.

Section 3 - Scales



The Natural Minor Scale

To find the **natural minor scale**, sing or play the Major scale, beginning and ending on *la*. This scale was originally a mode called the **Aeolian mode**.

C Major Scale beginning and ending on *la*

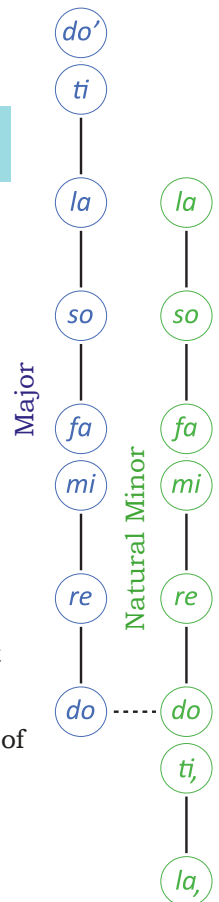

C Major and A minor are **related** keys as they share the same key signature.



There are many ways to work out the relative Major and minor keys. The easiest is to find *la* in a Major scale. This will be the **tonic** of the **relative minor** key.

For example, to find the relative minor of D Major, find *la* when D is *do*. (In the scale of D Major B is *la* therefore B minor is related to D Major and shares the same key).

D Major

B Natural Minor

Writing a Natural Minor Scale

To write E natural minor scale firstly, take the notes in the related Major scale:

(This example is based on writing the E natural minor scale therefore this is the G major scale).

Then write these notes beginning and ending on *la* to create the E natural minor scale:

W

Major and the Relative Minor Key Signatures

I

Click on the associated information sheet icon for key signatures in the bass clef.

Sharp Keys

(C Major/
A minor: 
do (ti) la

G Major/
E minor: 

D Major/
B minor: 

A Major/
F# minor: 

E Major/
C# minor: 

B Major/
G# minor: 

F# Major/
D# minor: 

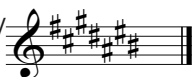
C# Major/
A# minor: 

Flat Keys

(C Major/
A minor: 
do (ti) la

F Major/
D minor: 

Bb Major/
G minor: 

Eb Major/
C minor: 

Ab Major/
F minor: 

Db Major/
Bb minor: 

Gb Major/
Eb minor: 

Cb Major/
Ab minor: 

Worksheet 14

W

S3 Scales 1 On the given staff, write one octave, ascending and descending, in quarter notes, of the natural minor scale with two sharps in the key signature. Write the letter names beneath each note.

S3 Scales 2 On the given staff, write one octave, ascending and descending, in quarter notes, of the natural minor scale with three flats in the key signature. Write the solfa beneath each note.

W

S3 Scales 3 Write the key signatures belonging to the following keys.

D minor G Major G minor B minor C Major F# minor C minor

S3 Aural Scale Recognition Three scales will be played twice each. Name each scale as Major or natural minor.

1. _____ 2. _____ 3. _____

Section 3 - Intervals



Diminished Intervals

A **diminished (dim) interval** is created by taking a **Perfect** or **minor interval** and making it **one semitone smaller** (or by making a **Major** interval **two semitones smaller** - one semitone smaller makes it minor, two semitones smaller makes it diminished).

To write a diminished 3rd **above** C:

= Major 3rd
 = minor 3rd
 = diminished 3rd

Or to write a diminished 3rd **below** E:

= Major 3rd
 = minor 3rd
 = diminished 3rd

A **double flat**, $\flat\flat$, lowers a note two semitones, a **double sharp**, $\sharp\sharp$, raises a note two semitones.

The letter name of an interval **MUST** remain the same as you alter the note or the number of the interval will change.



Augmented Intervals

An **Augmented (Aug) interval** is found by taking a Perfect or Major interval and making it one semitone larger (or by making a **minor** interval **two semitones larger** - one semitone larger makes it Major, two semitones larger makes it Augmented).

= Perfect 4th
 = Augmented 4th

When indicating a Major, Perfect or Augmented interval use capital letters (**Maj 3**, **Perf 4**, **Aug 4**) and when indicating a minor or diminished interval use lower case letters (**min 3**, **dim 5**).



Interval Alteration Rule:

Intervals getting bigger \uparrow **Augmented**
Major
minor
diminished \downarrow Intervals getting smaller

Intervals getting bigger \uparrow **Augmented**
Perfect
diminished \downarrow Intervals getting smaller

Intervals within the Natural Minor Scale (Aeolian Mode)

Major 2nd tone minor 2nd semitone Major 2nd tone Major 2nd tone minor 2nd semitone Major 2nd tone Major 2nd tone

Remember that *mi* to *fa* and *ti* to *do* are **ALWAYS** semitones.

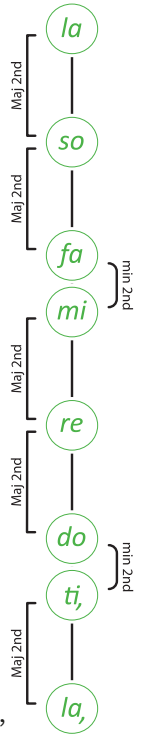

C Natural Minor Interval Pattern

la, ti, Major second, ti, do, minor second, do, re, Major second, re, mi etc



Practice Question 5: Aural Interval Recognition in a Melody

Listen to the following melody with the given rhythmic pattern. It is in a Major key. *Students only have the rhythm of the melody and the brackets on their score.*

- The first time the **Aural Interval Recognition in a Melody** question below is played, follow the given rhythm. Knowing this melody is in a Major key, confirm that the last note is *do* and write this above the last note. Hold the sound of this note in your head until the second playing begins to work out whether the first note is *do*.
- Preferably using solfa, derive and write the name of the first interval (the first pair of bracketed notes) in full in the space provided. Following a tone ladder and pointing to the pitches as you work out the distance between two notes may aid you. Repeat for the second interval.

Aural Interval Recognition in a Melody

1/34



Worksheet 15



S3 Intervals 1 Write these intervals above the given notes.

minor 6th dim 2nd Perfect 4th Major 3rd minor 3rd Aug 5th Major 2nd

S3 Intervals 2 A melody, in a natural minor key, will be played several times. The rhythm of the melody is printed below. Identify the first and last intervals (quality and number) and write your answers beneath the brackets.

1/35

S3 Intervals 3 Ascending intervals will be played twice. They will be one of the following: Major 2nd, Major 3rd, Major 6th, Major 7th, Perfect 5th or Perfect 8ve. Name the intervals you hear.

1/36

1. 2. 3. 4. 5. 6.

Section 3 - Melody

The following Israeli folksong "Alleluia" has no sharps or flats in the key signature, therefore, C is *do*.

However, the last note is A, or *la*, A is also the tonal centre of the song. To be a **tonal centre**, a particular note (and the key based around that note, in this case A minor) is most important tonally in the music. For example, the song begins on the tonic: *la*, the second phrase begins on the dominant: *mi* and ends on the mediant: *do* of A minor and the third phrase begins on *do*. These three notes: *la do* and *mi*, create the tonic triad of a minor key (see page 51). There are also many A minor scale fragments used throughout. This all indicates that "Alleluia" is in A natural minor.

W

Sing the A natural minor scale in solfa with handsigns and letter names then sing "Alleluia" in solfa with handsigns and in letter names.

S



Alleluia

Israeli Folksong

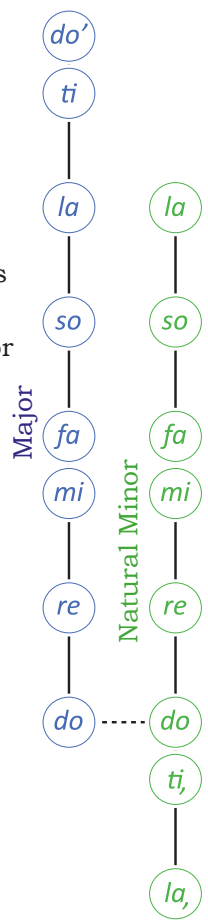

Melodic Transcriptions in Minor Keys

When completing a transcription in a minor key the process remains the same as when completing a transcription in a Major key.



Practice Question 6: Two Part Melodic Transcription

- Study the "Melodic Transcription" on the next page. Determine the key by studying the key signature and the last note (of the bass part). There is one flat (B \flat) in the key signature. This tells us that F is *do*. However, the bass part ends on a D or *la*, therefore this example is in the key of D natural minor. Write the D natural minor scale on this staff with solfa and letter names beneath each note:

2. Sing this scale in solfa and letter names.
3. The melody for Practice Question 6 will be played several times. Before it begins, note the rhythm given for you above the staff. This is the rhythm of the melody. The solfa of the first and last bars is given under this rhythm.
4. The first time you hear the melodic transcription listen and point to the rhythm above the staff. If you **recognise** any notes (such as the tonic: *la* or the dominant: *mi*) write the solfa of these notes under the rhythm where you heard them. You may remember the solfa of the last few notes as these will remain in your internal memory. Use the scale you have written (or a solfa tone ladder such as the natural minor one on page 36) to help recognise notes you hear.
5. Use further playings of the melodic transcription to continue writing the solfa you hear under the rhythm. When you are (fairly) sure your solfa is correct write this as notes on the staff. (Do not leave this until the end as looking at the notes written on the staff can help find mistakes).
6. Have the notes of this melody on the staff before the final playing. Use the final playing to check your completed melody by singing it in solfa in your head and pointing to the notes as you listen.

Melodic Transcription

As your knowledge of harmony improves it will help to study the bass part of multi-part transcriptions from a harmonic perspective. Decide which chords the melody could be based on etc. This can assist in choosing the notes in the part to be notated (i.e. notes that belong to the underlying chord progression are likely possibilities).

Continue using this process for **all melodic transcription** exercises.

In particular, write the transcription scale (the scale the transcription is based on with the solfa and letter names below) for **every** exercise. Where necessary, use manuscript or draw your own staff to write key information on.



Worksheet 16

Write the transcription scale out first for **all** transcriptions.

S3 Melodic Transcription 1

Worksheet 16 cont.

S3 Melodic Transcription 2

6/8 *d*

1/39

S3 Melodic Transcription 3 Transcribe the rhythm of this transcription first. Write the beat strokes and rhythmic shorthand to help.

12/8

1/40

S3 Melodic Transcription 4

4/4 *d*

1/41

W

S3 Melodic Composition Create a D natural minor melody by writing the rhythm on the rhythm staff, the solfa underneath this rhythm and then transferring this onto the treble staff below. Sing in solfa and in letter names once you have finished.

12/8

3

Section 3 - Chords



Major Triads in Scales

Major triads are found on the 1st, 4th and 5th scale degrees of a Major Scale:

Major Triads in the C Major Scale

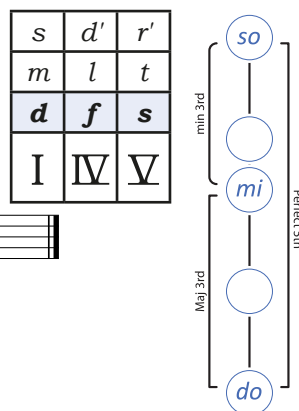

Major Triads in the A Harmonic Minor Scale

Major triads can be built on the 5th and 6th scale degrees of a harmonic minor scale:

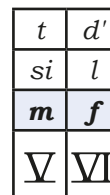

Note that the raised 7th in chord V turns what was originally a minor triad into a Major triad.



Worksheet 17

S3 Chords 1 Write a Major triad on each given note.

S3 Chords 2 Write a Major triad on each given note.

S3 Chords 3 Write the primary triads belonging to the Major key with the given key signature. Label each chord with its Roman numeral.

S3 Chords 4 Using a key signature, write the primary triads of A Major. Label each chord with its Roman numeral.

S3 Chords 5 Write the primary triads belonging to the Major key with the given key signature. Label each chord with its Roman numeral.

Section 3 - Chord Progressions



Practice Question 7: Recognition of a Chord Progression in a Major Key



1. A chord progression will be played several times. The chord progression played will be one of the following chord progressions (shown using Roman numerals):

1/42

a. $\overset{d}{I} - \overset{f}{IV} - \overset{d}{I} - \overset{s}{V}$ b. $I - V - IV - V$ c. $I - IV - V - I$

d. $I - V - I - IV$ e. $I - IV - V - IV$ f. $I - V - IV - I$

2. The tonic note is C. As preparation, sing the bassline, or tonic, of each possible progression in solfa and letter names. You may wish to write the solfa of each bass note above the Roman numerals. The first has been done for you.
3. As you listen make a note of the solfa or letter names of the bassline that you hear. Match each bassline note with a Roman numeral. For example, a chord built on F or *fa* would be chord IV in C Major.
4. When you know which progression has been played, circle it above. To check, inner hear the bassline in solfa as the progression is played for the final time.



Practice Question 8: Transcription of a Chord Progression in a Major Key

1. A chord progression will be played several times. The first chord, C Major, is the tonic chord, therefore this progression is in the key of C Major. This chord progression will use only **chords I IV, and V** (the primary triads).
2. The bass note is the root note of each chord. Write the solfa of the bassline **above** the harmonic grid below (beside each number) and the letter names of the bassline in the **Bass Note** boxes of the Harmonic Grid.
3. To check, sing (in your head) the bassline in solfa as the progression is played for the final time. **If preferred, the full chord name** can be written on the first set of numbered lines below the harmonic grid. For example, the chord built on the fourth scale degree of C Major (*fa*) would be an F Major chord as F is its bass note and the fourth chord of a Major key is a Major chord. **Alternatively, the Roman numeral** of each triad can be written on the second set of lines. For example, if the bass note is F, the Roman numeral would be IV as F is the fourth scale degree in C Major.

Use UPPER CASE Roman numerals to show Major triads.

Harmonic Grid 1. *d* 2. 3. 4.

Bass note	C			
Quality	Major			

1/43

OR 1. C Major 2. 3. 4.

OR 1. I 2. 3. 4.

The quality of a chord on a particular scale degree will **always** be the same. For example, a chord built on the first, fourth or fifth scale degree of a Major scale will always be Major.



Worksheet 18

S3 Recognition of a Chord Progression A chord progression, using only Major triads, will be played five times. Use the instructions from Practice Question 7 to complete this question. This chord progression will be one of the following:

1/44

- a. I - IV - I - V b. I - IV - V - IV c. I - IV - V - I
d. I - V - I - IV e. I - V - IV - V f. I - V - IV - I

S3 Transcription of a Chord Progression 1 and 2 Instructions

Two chord progressions, consisting of four chords each, will be played several times.

The first (tonic) chord is printed at the start of the progression.

Write your answers using the instructions from Practice Question 8.

These chord progressions use only the primary triads of the Major scale.

S3 Transcription of a Chord Progression 1

Harmonic Grid 1. *d* 2. 3. 4.

Bass note	C			
Quality	Major			

1/45



S3 Transcription of a Chord Progression 2

Harmonic Grid 1. *d* 2. 3. 4.

Bass note	C			
Quality	Major			

1/46

**S3 Chord Progression Theory**

Click on the associated video icon:  for instructions on how to complete this question type. The worksheet:  has worked examples of this question type.

A bass line is given on the staff below. Follow these steps to complete the treble part of this chord progression. The first (tonic) chord has been done for you.

1. On line 1. below each bass note write the solfa and letter name of that bass note.
2. On line 2. write the solfa of the notes that belong to that root position chord.
3. On line 3. write the letter names of the notes that belong to that root position chord.
4. Finally, rewrite these root position chords in a way that moves smoothly from one part to another. For example, as there is a C in the first and second chords, this note can remain in the same place on the treble staff for both chords. Also if possible, have *ti* leading to *do* and *fa* leading to *mi*. For example, the *ti* in the 4th chord leads up to *do'* in the final chord.

do/C

do mi so

C E G

Section 4 - Rhythm



Compound Time - Semiquavers



In compound time, **semiquavers** or **sixteenth notes** are usually grouped in six lasting for one beat (there are **six** equal sounds on a **beat** or **two** equal sounds on each **pulse**). Its rhythm name is **tika-tika-tika**.



Individual **semiquavers** are worth **one sixth** of a **beat** or **half** a **pulse**.



In compound time a **semiquaver rest** is a silence that lasts for **one sixth** of a **beat** or **half** a **pulse**.



Rhythmic Example 19

ti-ka-ti-ka-ti-ka ti - ti - ti etc



Rhythmic Example 20



Compound Time - $\frac{9}{8}$



$\frac{9}{8}$ is another compound time signature and can be described as **compound triple**.

This time signature has **three dotted crotchet beats** per bar and **nine quaver pulses** grouped in three groups of three:



Rhythmic Example 21



Worksheet 19

Write a rhythm set and shorthand for each transcription.

There are no rests in these transcriptions.

S4 Rhythmic Transcription 1

1/47

S4 Rhythmic Transcription 2

1/48

S4 Rhythmic Transcription 3

1/49

S4 Rhythmic Transcription 4

1/50

S4 Rhythmic Transcription 5

1/51



S4 Rhythmic Theory 1 Add barlines to the following rhythm.

S4 Rhythmic Theory 2 Complete these bars using only quavers. Group the notes so as to show the beats clearly.

Section 4 - Scales



The Harmonic Minor Scale

The **harmonic minor scale** is the minor scale most likely to be used when building chords (or harmony - this is why it is called the **harmonic** minor scale) in a minor key.

It is almost identical to the **natural minor scale**.

The only difference is the **raised 7th degree - so**  becomes **si** 

A Natural Minor Scale

A musical staff in treble clef showing the A Natural Minor Scale. The notes are: la, ti, do, re, mi, fa, so, la, so, fa, mi, re, do, ti, la. Below the notes are their corresponding letter names: A, B, C, D, E, F, G, A, G, F, E, D, C, B, A.

A Harmonic Minor Scale

A musical staff in treble clef showing the A Harmonic Minor Scale. The notes are: la, ti, do, re, mi, fa, si, la, si, fa, mi, re, do, ti, la. Below the notes are their corresponding letter names: A, B, C, D, E, F, G#, A, G#, F, E, D, C, B, A. A red arrow points from the 'so' note in the A Natural Minor scale above to the 'si' note in the A Harmonic Minor scale.

As the raised 7th is **not** found in the key signature it is called an **accidental**.

A diagram comparing three scales. The Major scale is shown as a vertical line of notes: do, ti, la, so, fa, mi, re, do. The Natural Minor scale is shown as a vertical line of notes: do, ti, la, so, fa, mi, re, do. The Harmonic Minor scale is shown as a vertical line of notes: do, ti, la, so, fa, mi, re, do. A green line connects the 'so' note in the Natural Minor scale to the 'si' note in the Harmonic Minor scale, indicating the raising of the 7th degree.

C Major and A Natural Minor:

A piano keyboard diagram showing the notes for C Major and A Natural Minor. The notes are: la, ti, do, re, mi, fa, so, la, ti, do. The notes are color-coded: la (green), ti (blue), do (green), re (blue), mi (green), fa (blue), so (green), la (blue), ti (green), do' (blue).

C Major and A Harmonic Minor:

A piano keyboard diagram showing the notes for C Major and A Harmonic Minor. The notes are: la, ti, do, re, mi, fa, so, la, ti, do. The notes are color-coded: la (green), ti (blue), do (green), re (blue), mi (green), fa (blue), so (green), si (green), la (blue), ti (green), do' (blue).

W

Writing a Harmonic Minor Scale

To write a harmonic minor scale, take the notes in the related Major scale:

do re mi fa so la ti do ti la so fa mi re do ti la,
B C# F# G A B C# D C# B A G F# E D C# B

(This example is based on writing the B harmonic minor scale therefore the relative Major is the D major scale).

Write these same notes beginning and ending on *la*, to create the B natural minor scale:

la, ti, do re mi fa so la so fa mi re do ti, la,
B C# D E F# G A B A G F# E D C# B

Finally, raise the 7th note of the natural minor scale to create the harmonic minor scale:

la, ti, do re mi fa si la si fa mi re do ti, la,
B C# D E F# G A# B A# G F# E D C# B

In this harmonic minor scale an **accidental** (a **sharp** in this case) is added to raise the A one semitone. However, if the 7th note was a flat (shown in the key signature) a different accidental would be needed (in this case a **natural**: \natural) in front of the note to raise it one semitone. If the 7th was already a sharp, we would have to use a **double sharp** (\times) to raise the 7th one semitone.

Worksheet 20

W

S4 Scales 1 Write the ascending and descending harmonic minor scale that is related to G Major on the given staff. Use a key signature and write in semibreves. Write the letter names beneath each note.

S4 Scales 2 Without a key signature (i.e. using accidentals), write the harmonic minor scale that begins on, and uses the note value of, the given tonic note. Write the solfa beneath each note.

S4 Scales 3 Write the descending harmonic minor scale with this key signature. Write the letter names beneath each note.

S4 Aural Scale Recognition Three scales will be played twice. Name each scale as Major, natural minor or harmonic minor.

1.

2.

3.

Section 4 - Intervals



Enharmonic Intervals



Enharmonic intervals are those which are written in a different way but sound the same.

For example these intervals look different on the staff:

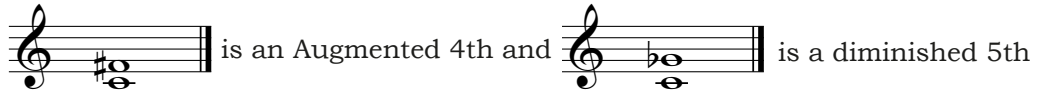

however, when played they will sound the same:



The interval of an **Augmented 4th/diminished 5th** can also be called a **tritone** as there are **three tones** between the bottom and top notes.

This interval occurs naturally in scales between *fa* and *ti* or *ti* and *fa*.



Compound Intervals



Compound intervals are intervals wider than an octave.

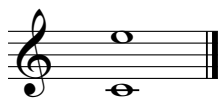

This interval is wider than an octave by a Major 3rd. Therefore, we could call this interval a **compound** (meaning plus one octave) **Major 3rd** or a **Major 10th** (this interval has 10 inclusive notes: C, D, E, F, G, A, B, C, D and E, and Major because the non-compound interval: is a Major 3rd).

Intervals within the Harmonic Minor Scale

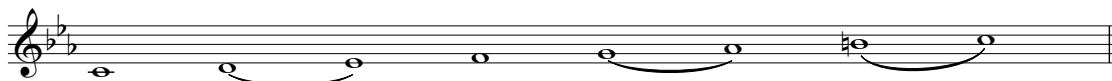

Major 2nd **tone** minor 2nd **semitone** Major 2nd **tone** Major 2nd **tone** minor 2nd **semitone** Aug 2nd **tone & 1/2** minor 2nd **semitone**

Note the **Augmented 2nd** (tone and a half) between the top two notes in this scale. *fa* to *so* is a Major 2nd, *fa* to *si* is one semitone larger, therefore it is an Augmented 2nd.



C Harmonic Minor Interval Pattern



7
re mi Ma jor se cond, mi fa mi nor se cond, fa si Aug men ted se cond, etc

re mi Ma jor se cond, mi fa mi nor se cond, fa si Aug men ted se cond, etc

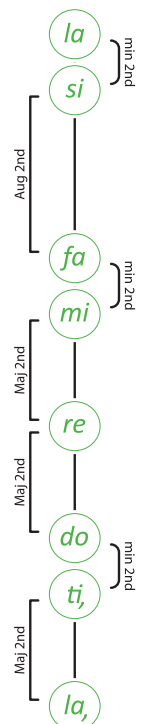

W

Worksheet 21

S4 Intervals 1 Beginning on the tonic note indicated, write the ascending harmonic minor scale. Identify the interval between each consecutive pair of notes and show the semitones using slurs.

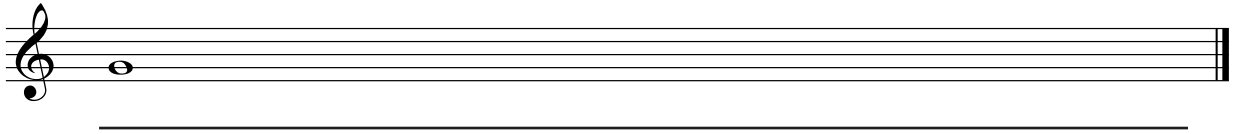

S4 Intervals 2 Name each given interval, then write an enharmonic equivalent for each in the adjacent empty bar by altering one of the notes. The first one has been done for you.

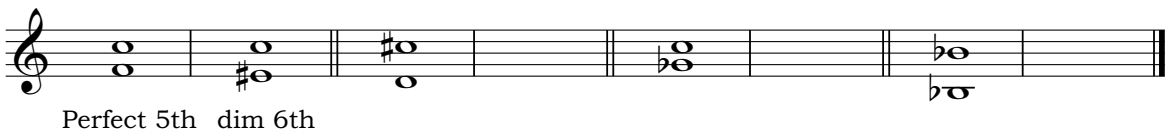

S4 Intervals 3 Name each given interval then write an enharmonic equivalent for each in the adjacent empty bar.

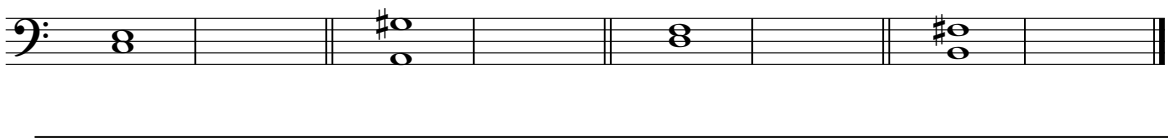

S4 Intervals 4 Name each interval in two ways. The first has been done for you.

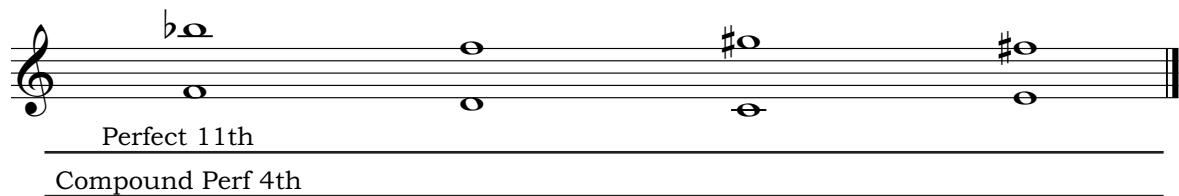

S4 Intervals 5 Identify the three bracketed intervals in the following melody. Write your answers (quality and number) beneath the brackets.



S4 Intervals 6 Descending intervals will be played twice. They will be one of the following: a Major 2nd, Major 3rd, Perfect 4th, Perfect 5th, Major 6th, Major 7th or Perfect 8ve. Name the intervals you hear.

1. _____ 2. _____ 3. _____ 4. _____ 5. _____ 6. _____

S4 Intervals 7 A melody, in a natural minor key, will be played several times. The rhythm of the melody is printed below. Identify the first and last intervals (quality and number) and write your answers beneath the brackets.



Section 4 - Melody



The following song "Kyrie" has no sharps or flats in the key signature, therefore, C is *do*.



do re mi fa so la ti do ti la so fa mi re do
C D E F G A B C B A G F E D C

However, the last note (and the tonal centre of the song - see page 36 for more information) is A, or *la*, therefore "Kyrie" is in A minor.

Now look through the notation of the song. The G# or *si* that occurs several times is the raised 7th note. Therefore, "Kyrie" is based on the A harmonic minor scale.

la, ti, do re mi fa si la si fa mi re do ti, la,
A B C D E F G# A G# F E D C B A

Sing the A harmonic minor scale in solfa with handsigns and letter names then sing "Kyrie" in solfa with handsigns and in letter names.

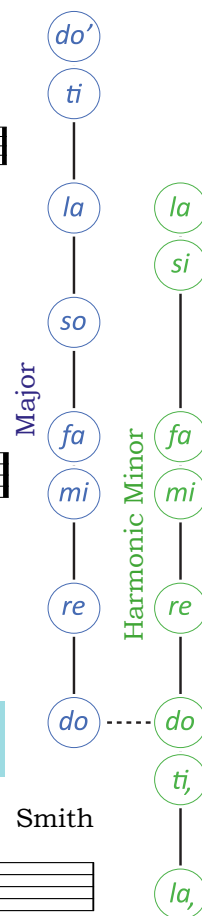

Kyrie



l l t d' t l si etc

Smith

The following song has three flats in the key signature indicating that E \flat is *do*.

The last note (and tonal centre of the song) is C, or *la*, therefore "Elodie" is in C minor.

Looking through the notation of the song, notice the B \natural or *si*. The 7th note of C minor is B \flat . B \natural is the raised 7th of C minor. Given the raised 7th, "Elodie" is based on the C harmonic minor scale. Sing the C harmonic minor scale in solfa with handsigns and letter names, then sing "Elodie" in solfa with handsigns and in letter names.

la, ti, do re mi fa si la si fa mi re do ti, la,
C D E \flat F G A \flat B C B A \flat G F E \flat D C



Elodie

Smith



Worksheet 22

Write the transcription scale out first for **all** transcriptions.

S4 Melodic Transcription 1

1/55

S4 Melodic Transcription 2

1/56

S4 Melodic Transcription 3

1/57



S4 Melodic Composition Create a melody in A harmonic minor by writing the rhythm on the rhythm staff, the solfa underneath this rhythm and then transferring this onto the treble staff below. Sing in solfa and in letter names once you have finished.

Section 4 - Chords



The Minor Triad

A minor triad (in root position) is made up of a root note, a note a minor 3rd and a note a Perfect 5th above the root note.

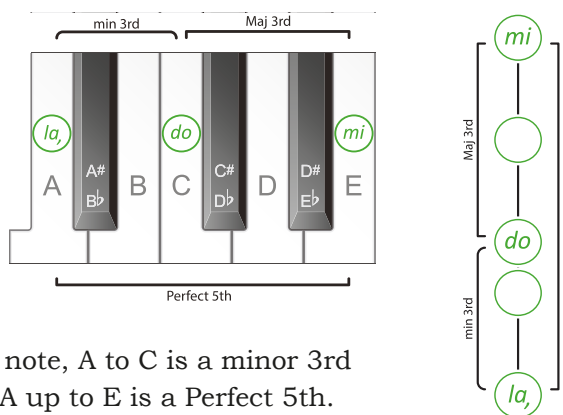

Intervals within the A Minor Triad

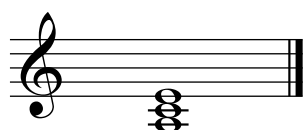

In this chord, A is the root note, A to C is a minor 3rd and C to E is a Major 3rd. A up to E is a Perfect 5th.

Labelling Minor Triads

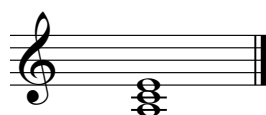

Chord Name: A minor triad (it is the minor triad built on A)

Roman numeral with Figures: Chord vi⁵ in C Major or **Chord i⁶** in

A harmonic minor (lower case Roman numeral, indicating the chord is minor, Roman numeral showing the scale degree the chord is built on and the ⁵ indicating that there is a 5th and a 3rd above the root note).

Tonal or Functional Name: A minor tonic triad (all the notes in this triad belong to the A harmonic minor scale and it is built on the tonic of A minor).

Minor Triads - in Major and Minor Keys

Minor triads can be built on the 2nd, 3rd and 6th scale degrees of a Major scale:

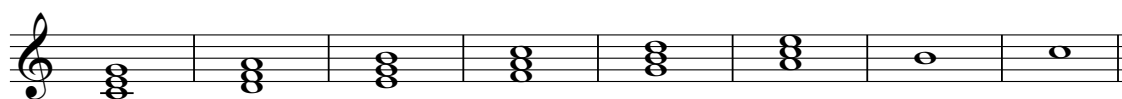

<i>l</i>	<i>t</i>	<i>m'</i>
<i>f</i>	<i>s</i>	<i>d'</i>
<i>r</i>	<i>m</i>	<i>l</i>
<i>ii</i>	<i>iii</i>	<i>vi</i>

and on the 1st and 4th scale degrees of a harmonic minor scale:

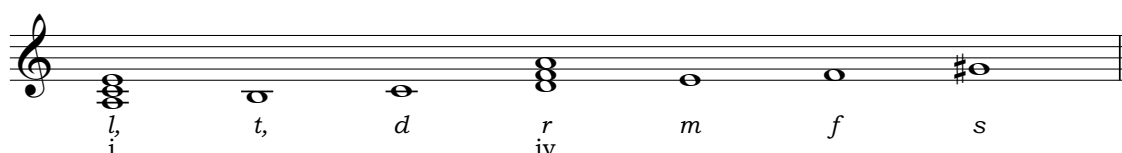

<i>m</i>	<i>l</i>
<i>d</i>	<i>f</i>
<i>l, r</i>	
<i>i</i>	<i>iv</i>

A Minor Triad Melodically

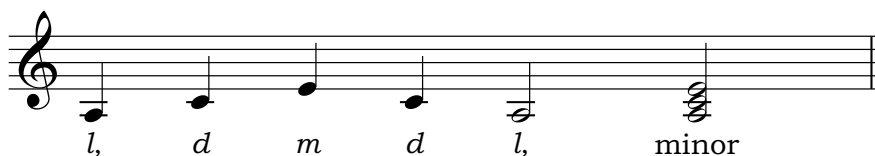

Section 4 - Chord Progressions



Primary Triads in a Minor Key

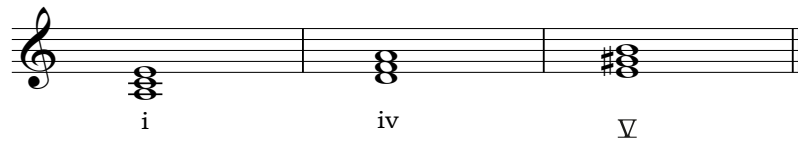

Note the use of the raised 7th from the harmonic minor scale in chord V which makes the quality of this chord Major.

C Minor Primary Triads



Worksheet 24

S4 Chord Progressions Using a key signature, write the three primary triads of D harmonic minor. Label them with Roman numerals.

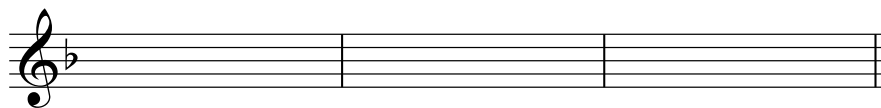

Recognition of a Bassline Instructions: A chord progression, using only the primary triads in a minor key, will be played several times. The given bass note of the first chord is the tonic. Write the solfa or letter names of the bassline for each chord played.

S4 Recognition of a Bassline 1

	Chord 1	Chord 2	Chord 3	Chord 4
Bass note	la/A			

1/59

S4 Recognition of a Bassline 2

	Chord 1	Chord 2	Chord 3	Chord 4
Bass note	la/B			

1/60

S4 Chord Progression Three chord progressions, consisting of four chords, will be played. Each progression will begin on the tonic chord, either I in Major or i in minor. Identify whether each chord progression is in a Major or a minor key (using the tonic chord as a guide).

1/61

1.

2.

3.

Section 4 - Revision & Practice Questions

Theory Revision



S4 Chord Progressions A bass line is given on the staff below. Follow these steps to complete the treble part of this chord progression. The first (tonic) chord has been done for you.

1. On line 1. below each bass note write the solfa and letter name of that bass note.
2. On line 2. write the Roman numeral belonging to that root position chord.
3. On line 3. write the solfa of the notes that belong to that root position chord.
4. On line 4. write the letter names of the notes that belong to that root position chord.
5. Finally, rewrite these root position chords in a way that moves smoothly from one part to another. Where possible, keep the same notes in the same position, and have *ti* leading to *do* and *fa* leading to *mi*.

la/A

 i

 la do mi

 A C E



S4 Rhythm Compose a compound triple rhythm on the given staff.



Musicianship Practice - Practice each task as many times as possible

PRACTICE ACTIVITIES

- Read compound time rhythms in rhythm names while conducting the pulse
- Write compound time rhythms in shorthand
- Compose compound time rhythms then read in rhythm names while conducting the pulse
- Sing the harmonic minor scale in solfa with handsigns
- Sing the harmonic minor scale in letter names in A, D and E minor
- Write the harmonic minor scale in treble or bass clef in A, D and E minor
- Sing all Major & minor 3rds belonging to the Major scale, in solfa with handsigns
- Sing the harmonic minor scale, naming the consecutive intervals, in solfa with handsigns
- Sing harmonic minor melodies in solfa with handsigns
- Compose harmonic minor melodies then sing in solfa with handsigns
- Sing the minor triad naming the consecutive intervals in solfa with handsigns
- Sing the minor triad, using all different possible solfa, with handsigns (page 51)
- Sing chord progressions from basslines in solfa with handsigns

Rhythm Review

Crotchet Beat Time Signatures and Rhythms

Simple Duple: Two crotchet beats per bar		Simple Triple: Three crotchet beats per bar		Simple quadruple (common time): Four crotchet beats per bar	
Rhythms lasting for one crotchet beat:					
Rhythms lasting for two crotchet beats:					
Rhythm lasting for three crotchet beats:					
Rhythm lasting for four crotchet beats:					

Dotted Crotchet Beat Time Signatures and Rhythms

Compound Duple: Two dotted crotchet beats per bar		Compound Triple: Three dotted crotchet beats per bar		Compound quadruple: Four dotted crotchet beats per bar	
Rhythms lasting for one dotted crotchet beat:					
Rhythms lasting for two dotted crotchet beats:					

Quaver Beat Time Signatures and Rhythms

Simple Triple:					
Rhythms lasting for three quaver beats:					



Practice Question 9: Recognition of Rhythms

- Practice Question 9 is a four bar, two part score with two empty bars. Below this are four two bar rhythmic options (labelled A. to D.) one of which will be the rhythm played for Practice Question 9. Before the first playing, study the rhythmic options, inner hearing them as you do, noting where they differ and where they are the same. Consider creating a map for your ears to follow. (*The associated video shows how to do this in detail*).
- Listen to Practice Question 9 and choose which rhythmic option is being played in the empty bars.
- Circle the correct rhythm.

Rhythmic Recognition

1/62

Worksheet 25

Write a rhythm set and shorthand for each of these transcriptions. There are no rests in these transcriptions.

S5 Rhythmic Transcription 1

1/63

S5 Rhythmic Transcription 2

1/64

S5 Rhythmic Recognition

1/65

W

S5 Rhythm Compose a simple triple rhythm (using the time signature with quaver beats) on the given staff. Perform your rhythm by reading the rhythm names while conducting.

Section 5 - Scales



The Melodic Minor Scale

The **melodic minor scale** is the scale most likely to be used when writing a **melody** in a minor key.

There are two distinct forms of the **melodic minor scale**: the **ascending** form and the **descending** form.

The Melodic Minor Scale - Ascending Form

The **ascending** form of the **melodic minor scale** is almost identical to the **harmonic minor scale**.

The only difference is the **raised 6th degree** -

fa  becomes **fi**  in addition to **si** 

the already raised 7th note:

A Harmonic Minor Scale - Ascending

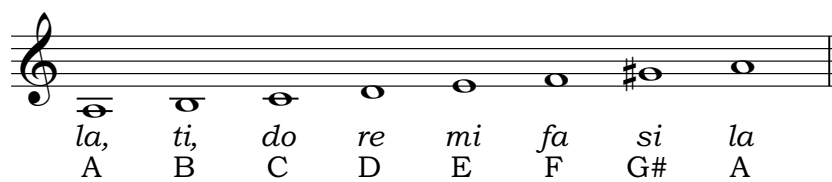

A Melodic Minor Scale - Ascending

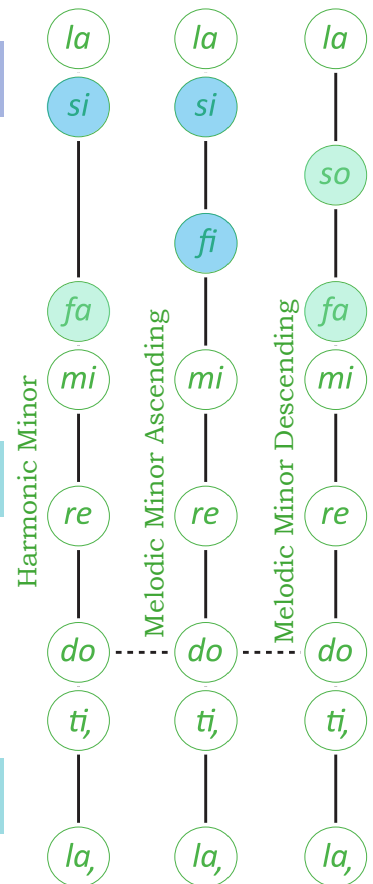
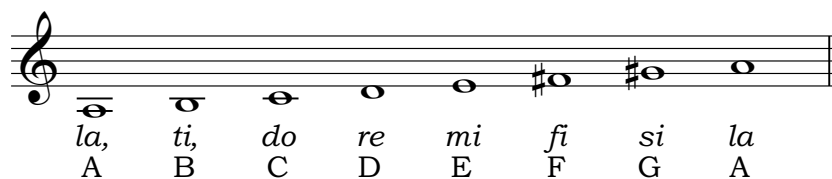

The Melodic Minor Scale - Descending Form

The **descending** form of the **melodic minor scale** is **identical** to the descending form of the **natural minor scale**:

A Natural Minor Scale Descending = A Melodic Minor Descending

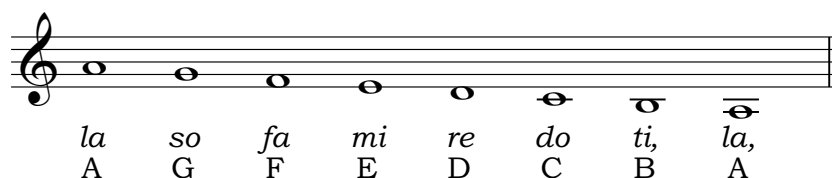

The Melodic Minor Scale - Ascending and Descending Form

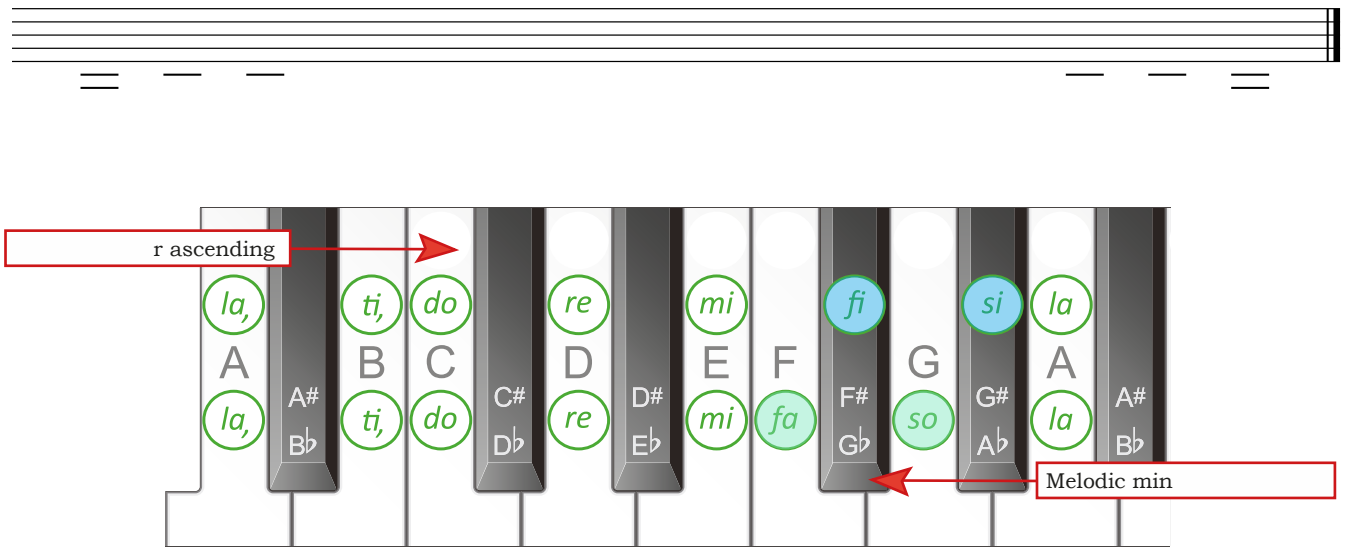

W

Writing a Melodic Minor Scale

To write a melodic minor scale, take the notes in the related Major scale:

(This example is based on writing the G melodic minor scale therefore the relative Major is the B \flat major scale).

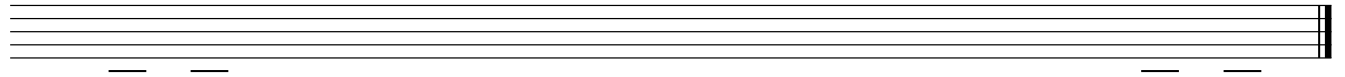

Write these same notes beginning and ending on *la* to create the G natural minor scale:

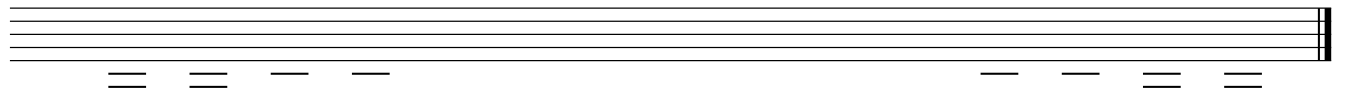

In the ascending part of the scale, raise the 6th and 7th notes of the natural minor scale and in the descending part of the scale lower them back to their original pitches. (The descending form of the melodic minor **IS** the natural minor scale).

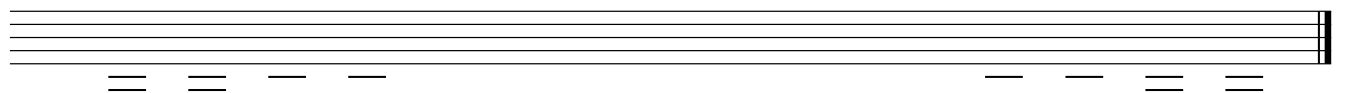

In this scale we have had to add several **accidentals**. On the way up: a natural: \natural to raise the E \flat one semitone and a sharp: \sharp to raise the F one semitone. On the way down, we need to add a natural sign to the F (to cancel out the sharp) and a flat sign to the E to return these notes to their natural forms.



Practice Question 10: Visual Key Recognition (Part 1)



To determine the key or tonality of a melody, look at its key signature, last note and other important notes within the melody itself. This flow chart outlines the required steps.

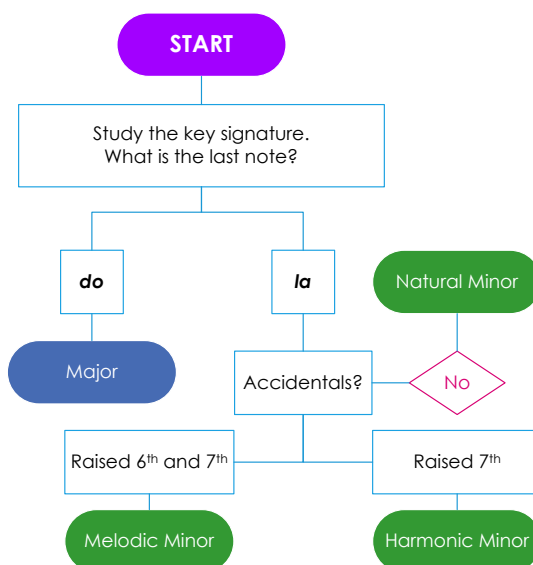

1. **Study the key signature of this melody. What is the last note?** There two flats: B \flat and E \flat in the key signature indicate that B \flat is *do*. This means the last note: G is *la*.
2. **Are there any accidentals? If so, is there a raised 7th? Yes** There is an F \sharp in the 4th bar.
3. **Is there a raised 6th? Yes** There is also an E \sharp in the 4th bar. Therefore, this melody is in the key of **G melodic minor**.

Other aspects of this melody that can help confirm the tonality are:

Important notes:

- the E \sharp and F \sharp in the 4th bar and another F \sharp in the 6th bar. In G minor, E \sharp will be *fi* and F \sharp will be *si*;
- the appearance of notes from the natural minor scale (the descending melodic minor scale): E \flat and F \natural , in bars 3, 4 and 7;
- three of the phrases in this melody end on the tonic: *la*, two begin on *do* and two on *la*;
- *la*, the tonic, appears nine times (out of a total of 36 notes), *mi*, the dominant, appears six times as does the mediant, *do*, (also the middle note of the tonic triad of a minor key).

Scalic or other passages that highlight a tonality:

- in bars 3 and 7 there is part of the descending scale of G melodic minor.
- in bar 5 there is part of an ascending scale of G melodic minor.
- in the 2nd and 4th bars there is part of the ascending G melodic minor scale leading to the tonic.

The **melodic minor scale** is the **ONLY** scale you have learned so far that can have **TWO** of the same letter name but with different alterations: F \natural and F \sharp and E \flat and E \sharp in the one scale.

Although the melodic minor **scale** has the raised 6th and 7th on the way up and the natural minor on the way down, this does **NOT** mean that melodic minor **melodies** must always have the raised 6th and 7th on the way up and the natural form in descending passages.

Worksheet 26

S5 Key Recognition 1 Write the tonality (key) for the following melody in the space provided. List three elements in each melody that indicate this choice. The melodies may be either Major, natural minor harmonic minor or melodic minor.



Tonality:

Element 1:

Element 2:

Element 3:

S5 Key Recognition 2 Write the tonality (key) for the following melody in the space provided. List three elements in each melody that indicate this choice. The melodies may be either Major, natural minor, harmonic minor or melodic minor.

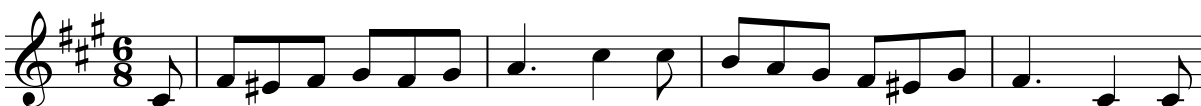

Tonality:

Element 1:

Element 2:

Element 3:

S5 Key Recognition 3 Write the tonality (key) for the following melody in the space provided. List three elements in each melody that indicate this choice. The melodies may be either Major, natural minor, harmonic minor or melodic minor.



Tonality:

Element 1:

Element 2:

Element 3:

S5 Key Recognition 4 Write the tonality (key) for the following melody in the space provided. List three elements in each melody that indicate this choice. The melodies may be either Major, natural minor, harmonic minor or melodic minor.



Tonality:

Element 1:

Element 2:

Element 3:

Section 5 - Intervals

Ascending melodic minor
Descending melodic minor

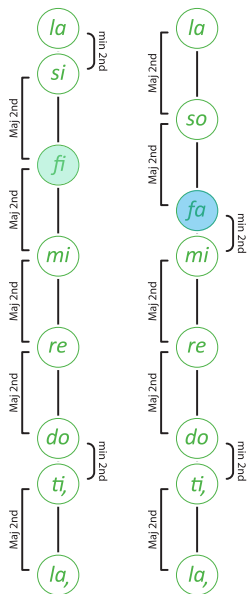

Intervals within the Melodic Minor Scale

C Melodic Minor Interval Pattern

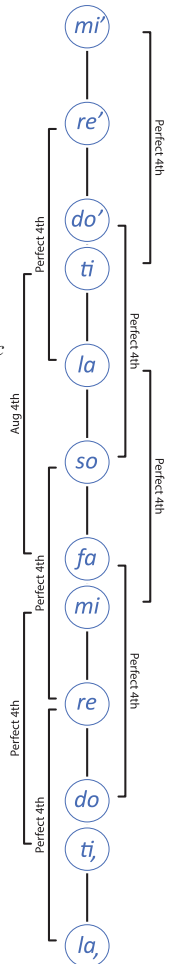

Ascending & Descending Perfect & Augmented 4ths

Worksheet 27

S5 Intervals Write the name of this scale and label the intervals between each pair of adjacent notes.

Scale name: _____

Section 5 - Melody

W Use the flow chart on page 60 to work through the steps required to determine the tonality of "Novalley".

- Study the key signature of this melody. What is the last note?** There is nothing in the key signature indicating that C is *do*. This means the last note: A is *la*.
- Are there any accidentals? If so, is there a raised 7th? Yes** There is an F# in the 6th bar.
- Is there a raised 6th? Yes** There is also a G# in the 6th bar. Therefore, this melody is in the key of **A melodic minor**:

la, ti, do re mi fi si la so fa mi re do ti, la,
A B C D E F# G# A G# F# E D C B A

Sing the A melodic minor scale in solfa with handsigns and letter names then sing "Novalley" in solfa with handsigns and in letter names.

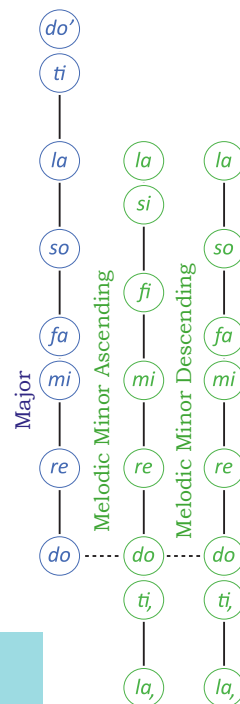

S
M Novalley

Smith

CE Worksheet 28

Write the transcription scale out first for all transcriptions and, where necessary, work out the rhythm of the melody.

S5 Melodic Transcription 1

S5 Melodic Transcription 2

1/66

1/67

Worksheet 28 cont.

S5 Melodic Transcription 3

Musical notation for S5 Melodic Transcription 3. The top part shows a single melodic line in 2/4 time with a key signature of one sharp (F#). The bottom part shows a piano accompaniment in 2/4 time with a key signature of two sharps (F# and C#).

1/68

S5 Melodic Transcription 4

Musical notation for S5 Melodic Transcription 4. The top part shows a single melodic line in 2/4 time with a key signature of one flat (Bb). The bottom part shows a piano accompaniment in 2/4 time with a key signature of two flats (Bb and Eb).

1/69

S5 Melodic Transcription 5

Musical notation for S5 Melodic Transcription 5. The top part shows a single melodic line in 6/8 time with a key signature of two sharps (F# and C#). The bottom part shows a piano accompaniment in 6/8 time with a key signature of two sharps (F# and C#).

1/70

S5 Melodic Transcription 6

Musical notation for S5 Melodic Transcription 6. The top part shows a single melodic line in 4/4 time with a key signature of two sharps (F# and C#). The bottom part shows a piano accompaniment in 4/4 time with a key signature of two sharps (F# and C#).

1/71

S5 Melodic Transcription 7

Musical notation for S5 Melodic Transcription 7. The top part shows a single melodic line in 3/4 time with a key signature of one flat (Bb). The bottom part shows a piano accompaniment in 3/4 time with a key signature of one flat (Bb).

1/72

Section 5 - Chords



Worksheet 29



S5 Chords 1 Write the following triads on the given staff using accidentals where necessary.

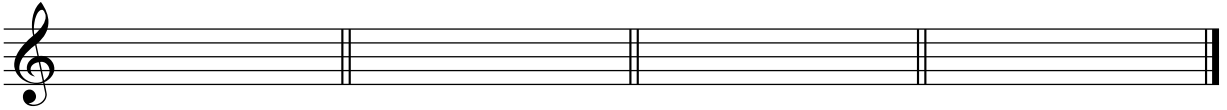

F Major

D minor

C minor

A Major

S5 Chords 2 Write the following triads on the given staff using accidentals where necessary.

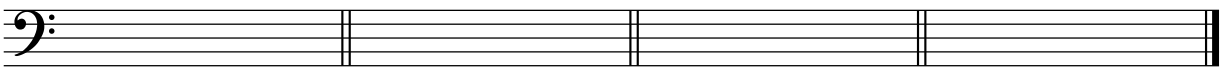

C Major

E minor

E \flat Major

A minor

S5 Chords 3 Write, and label (using Roman numerals), the primary triads in G Major in the treble clef, and in B minor in the bass clef. Use key signatures as required.



S5 Chords 4 Write, and label (using Roman numerals), all the Major triads you would find in the following two Major keys with these key signatures.



S5 Chords 5 Write, and label (using Roman numerals), all the minor triads you would find in the following two harmonic minor keys with these key signatures.



S5 Chords 6 Write, and label (using Roman numerals), all the Major and minor triads you would find in the following Major keys with this key signature.

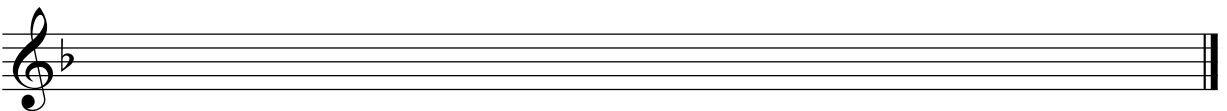

Section 5 - Chord Progressions



Cadence



The last two chords at the end of a phrase or section of music are called a **cadence**.

Perfect Cadence (Full Close)

A **perfect cadence** is a final, or full close cadence. When used at the end of a composition, a perfect cadence will sound finished (like a full stop).

A **perfect cadence** consists of chord V (the chord built on the fifth note of the scale) followed by chord I/i (the chord built on the first degree of the scale). This example is a perfect cadence in the key of C Major. A perfect cadence is often used at the end of a piece of music as it sounds final or complete.

V
 I

These chords have been written over two octaves i.e. across the bass and treble clefs. Although they use the notes you are familiar with (i.e. G, B and D for chord V) they are in a different order, with the root note doubled in the bass clef. This is called **piano style** writing.

Plagal Cadence (Amen or Church Cadence)

A **plagal cadence** is another final cadence and will also sound finished if used at the end of a composition. It is often used as a hymn ending.

A **plagal cadence** is made up of chord IV/iv followed by chord I/i . This example is a plagal cadence in the key of C Major.

IV
 I

A plagal cadence is also used at the end of a piece of music, however it is a weaker ending than the perfect cadence. Hearing the **tonic note** in both final chords may indicate a plagal cadence.

Practice Question 11: Recognition of Cadences

- Five chord progressions consisting of five chords each will be played. The last two chords of each progression will create either a perfect or plagal cadence.
- Using your knowledge of chords, basslines and the sound or effect of perfect and plagal cadences, identify the cadences at the end of each progression in the spaces provided.

1/73

1.

2.

3.

4.

5.

Chord Chart of Major and Minor Triads: Major Key

Scale solfa:	<i>d</i>	<i>r</i>	<i>m</i>	<i>f</i>	<i>s</i>	<i>l</i>	<i>t</i>
Chord:	I	ii	iii	IV	V	vi	

Chord Chart of Major and Minor Triads: Harmonic Minor Key

Scale solfa:	<i>l</i>	<i>t</i>	<i>d</i>	<i>r</i>	<i>m</i>	<i>f</i>	<i>si</i>
Chord:	i			iv	V	VI	



Practice Question 12: Transcription of a Chord Progression in a Minor Key

1. A chord progression, using only Major and minor triads, will be played several times. The first chord, A minor, is the tonic chord, therefore this progression is in the key of A harmonic minor. This chord progression will use only chords i, iv, and V (the primary triads).
2. The bass note is the root note of each chord. Listen to the bassline and write the solfa **above** the harmonic grid given below (beside each number) and the letter names of the bassline in the **Bass Note** boxes of the harmonic grid.
3. Focus on the last two chords and identify the cadence, writing it in the space provided below the harmonic grid.
4. Listen to the quality of each chord and write this in the quality boxes. (In this example the chords can be either Major or minor). Remember the quality of each chord remains the same for each tonality. For example, if you have D as your bass note and Major in the Quality box one of these must be incorrect as the chord built on D (the 4th note) in a harmonic minor key is minor not Major.
5. To check, sing the bassline in solfa as the progression is played for the final time.

Harmonic Grid 1. *l* 2. 3. 4.

Bass note	A			
Quality	minor			

1/74

Cadence: _____



Worksheet 30

S5 Recognition of a Chord Progression A harmonic minor chord progression, using only Major and minor triads, will be played three times. All chords are in root position. Circle the progression you hear. The chord progression will be one of the following:

1/75

- a. i - iv - i - V b. i - V- iv - V c. i - iv - V- I
- d. i - V- i - iv e. i - VI- iv- V f. i - V- vi - V

S5 Chord Progression A chord progression, consisting of four chords, will be played several times. The first (tonic) chord is printed at the start of the progression. (This chord progression will use only the primary triads of the harmonic minor scale). Using the harmonic grid, identify the other chords.

1/76

Harmonic Grid 1. *l* 2. 3. 4.

Bass note	A			
Quality	minor			

Section 5 - Revision & Practice Questions

Theory Revision

W

S5 Scales Using a key signature, write the melodic minor scale beginning on the given note, in the treble clef, one octave, ascending and descending. Write the solfa AND letter names beneath each note.

E

W

S5 Intervals Write the ascending melodic minor scale with the given key signature, in semibreves. Identify the interval between each consecutive pair of notes.

W

S5 Melodic Composition Create a melody in A melodic minor by writing the rhythm on the rhythm staff, the solfa underneath this rhythm and then transferring this onto the treble staff below. Sing in solfa and in letter names once you have finished.

P

Musicianship Practice - Practice each task as many times as possible

PRACTICE ACTIVITIES

- Read two part rhythms in rhythm names and perform both parts in various ways
- Write simple triple time rhythms in shorthand
- Compose simple triple rhythms then read in rhythm names while conducting the beat
- Sing the melodic minor scale in solfa with handsigns
- Sing the melodic minor scale in letter names in B and G minor
- Write the melodic minor scale in treble or bass clef in various keys
- Sing all Perfect and Augmented 4ths in solfa with handsigns
- Sing the melodic minor scale, naming the consecutive intervals, in solfa with handsigns
- Sing melodic minor melodies in solfa with handsigns
- Compose melodic minor melodies then sing in solfa with handsigns
- Sing the Major and minor triads, from the same bottom note, in solfa with handsigns
- Sing harmonic minor chord progressions from basslines in solfa with handsigns

Section 6 - Rhythm



More Semiquavers in Compound Time



These three rhythms are combinations of two semiquavers and two quavers commonly found in compound time.



All three of these rhythms are worth one dotted crotchet beat (equal to three quaver pulses) in compound time.



Rhythmic Example 24



Rhythmic Example 25

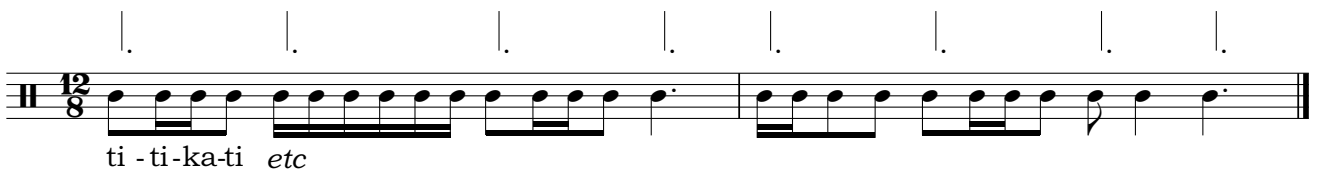

Rhythmic Example 26



Anacrusis



An anacrusis is an upbeat, or incomplete bar, found before the first complete bar of music.

Rhythmic Example 27 has one crotchet beat before the first bar line. This is the anacrusis. As this is not a complete bar we do not refer to this as the first bar, rather the first bar is the first full, or complete, bar of a piece of music (see bar numbers).



Rhythmic Example 27



The last bar of the above exercise only has one beat. This is the traditional notation for completing the anacrusis bar "mathematically" i.e. the value of the notes in the anacrusis and the last bar equal one full bar. Alternatively, the last bar can also be a complete bar as in Rhythmic Example 28.



Rhythmic Example 28



Rhythmic Example 29



Worksheet 31

Write a rhythm set and shorthand for each of these transcriptions. There are no rests in these transcriptions.

S6 Rhythmic Transcription 1



1/77

S6 Rhythmic Transcription 2

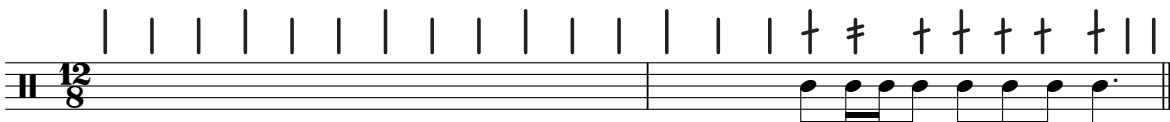

1/78

S6 Rhythmic Transcription 3

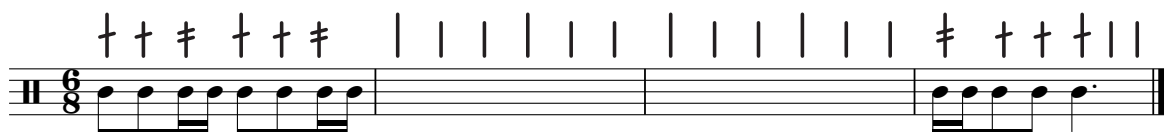

1/79

S6 Rhythmic Transcription 4

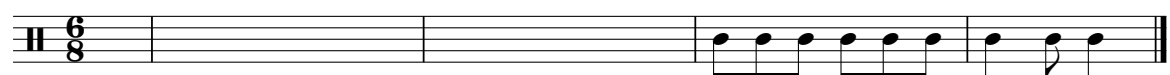

1/80

S6 Rhythmic Transcription 5

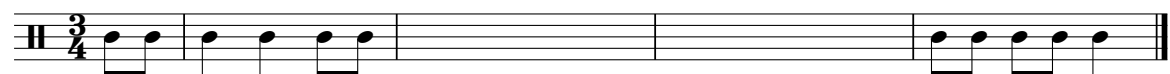

1/81

S6 Rhythmic Transcription 6

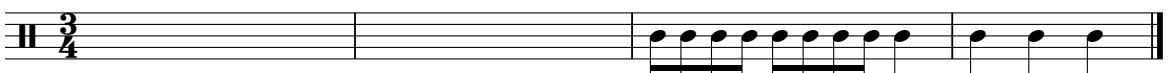

1/82

Worksheet 31 cont.

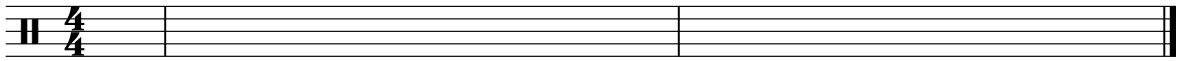
S6 Rhythmic Transcription 7

1/83

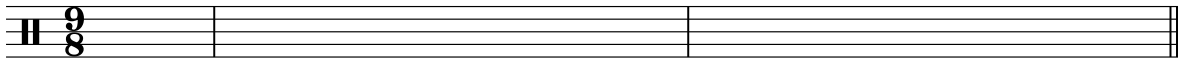
S6 Rhythmic Transcription 8

1/84

S6 Rhythmic Recognition

1/85

A B

C D

S6 Rhythm Compose four bars of compound triple time rhythm using as many different known rhythms as possible. Perform your rhythm by reading the rhythm names while conducting.

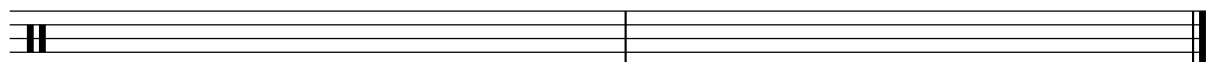
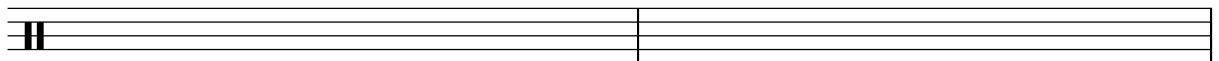

S6 Rhythm Theory Complete each bar using at least one semiquaver. No two bars may be the same.

Section 6 - Scales



Diatonic & Chromatic Scales

The terms **Diatonic** and **Chromatic** have several meanings depending on the context in which they are used.

A **diatonic scale** is one with eight notes and seven intervals. No two note names are the same (except, of course, for the tonic which is repeated at the top). Typical examples are the Major and minor scales learned so far.

A **chromatic scale** consists of 12 different notes (plus one upper tonic), each being divided by a semitone, (see page ?).

When we refer to notes in a melody or a chord as being **diatonic** it means they belong to the key of the melody (they are not altered by accidentals).

When we refer to notes in a melody or a chord as being **chromatic** it means they **do not** belong to the key of the melody (they are altered by accidentals).

For example, this melody is in A Major, therefore, all melodic notes that **are** found in the A Major scale are **diatonic** - they belong to the A Major scale (written below the melody). Notes within the melody **not** found in the A Major scale are **chromatic** notes (circled in red).



Melody in A

A Major Scale

Worksheet 32

S6 Diatonic Note Recognition Instructions

Study the melody given and determine the **key** it is based on. Write out this **scale** on the blank staff provided. Circle any notes in the melody that are **not** found in the scale you have just written. These notes are **chromatic**, in other words, they **do not** belong to the key the melody is in.

S6 Diatonic Note Recognition 1

Worksheet 32 cont.

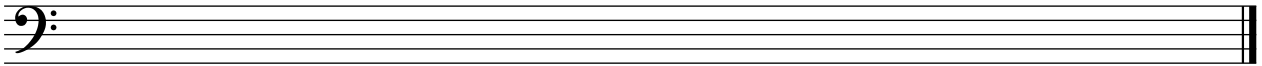
S6 Diatonic Note Recognition 2

S6 Scales 1 Write the key signatures of the following scales.

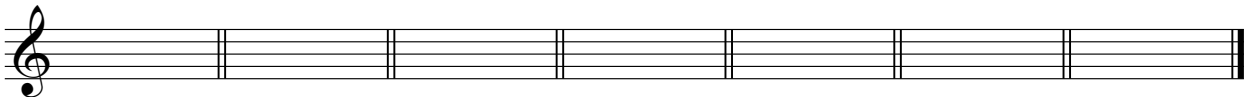

G Major C minor F minor E♭Major G minor D Major F# minor

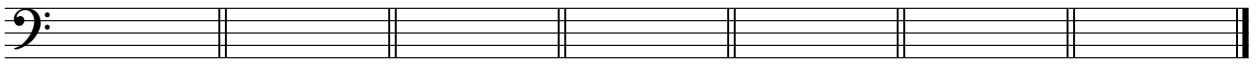

A Major C Major F Major B♭Major D minor E minor B minor

S6 Scales 2 Beginning on, and using the note value of, the given note, write the ascending melodic minor scale using a key signature. Identify the interval between each consecutive pair of notes.

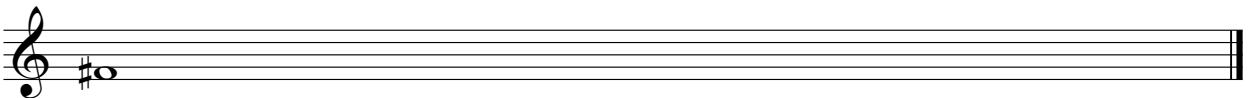

S6 Scales 3 Write the notes found in the C Major scale using enharmonics for each note e.g. instead of C you could write B# or D♭.

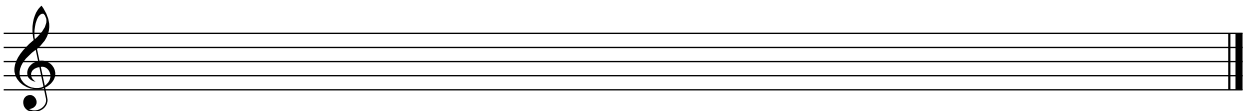

S6 Scales 4 Complete the following two charts.

Scale Degree	Tonal Name	Scale Degree	Tonal Name
1	Tonic	2	
7			Dominant
3		6	

Number of flats in key signature	Name of flats (in key signature order)	Tonic note of Major scale	Tonic note of minor scale
4	B♭ E♭ A♭ D♭	A♭	F
2			
6			
3			

Section 6 - Intervals



Diatonic and Chromatic Intervals

A **diatonic interval** is one that is found in a Major or minor scale.

For example, C to D \flat is a diatonic interval because it can be found in several scales.

A diatonic interval must have two different note names.

A **chromatic interval** is one that is found only in a chromatic scale i.e. it cannot be found in a Major or minor scale.

For example, an Augmented Unison (e.g. C to C \sharp) is a chromatic interval because it cannot be found in any Major or minor scale.

Chromatic Intervals

Examples of chromatic intervals:

Augmented unison diminished 8ve

Augmented 3rd diminished 6th

Augmented 6th diminished 3rd



Worksheet 33

S6 Intervals 1 Name each interval and then write two more intervals that would sound the same. The first has been done for you.

Aug 4 dim 5 dim 5

S6 Intervals 2 Name these intervals then circle all intervals that are chromatic.

S6 Intervals 3 Write these intervals below the given notes.

Major 3rd dim 5th minor 7th Aug 2nd Major 6th Aug 7th minor 3rd

Section 6 - Melody



Melodic Transcriptions in Melodic Minor Keys



When completing a transcription in a melodic minor key the process remains the same as when completing a transcription in a minor key (see pages 36 and 37). The only important difference is the way the transcription scale is written out prior to beginning the transcription itself. For example, if the melody to be transcribed is in G melodic minor the transcription scale would look like this:

l *t* *d* *r* *m* *f* *fi* *s* *si* *l*
 G A B \flat C D E \flat E F F \sharp G

Notice that the "scale" is written ascending only (simply to save time) and therefore needs to include both the notes in the ascending version of the melodic minor (*fi* and *si*) and the descending version (*so* and *fa*).



Worksheet 34

Write the transcription scale out first for all transcriptions and, where necessary, work out the rhythm of the melody.

S6 Melodic Transcription 1

1/86

S6 Melodic Transcription 2

1/87

Worksheet 34 cont.

S6 Melodic Transcription 3

1/88

S6 Melodic Transcription 4

1/89

S6 Melodic Transcription 5

1/90

S6 Melody Transpose the following A Major melody into F Major. Write the solfa beneath the two given scales and the melody to be transposed. Use this information to aid transposing.

Section 6 - Chords



The Diminished Triad

A diminished triad (in root position) is made up of a root note, a note a minor 3rd and a note a diminished 5th above the root note.

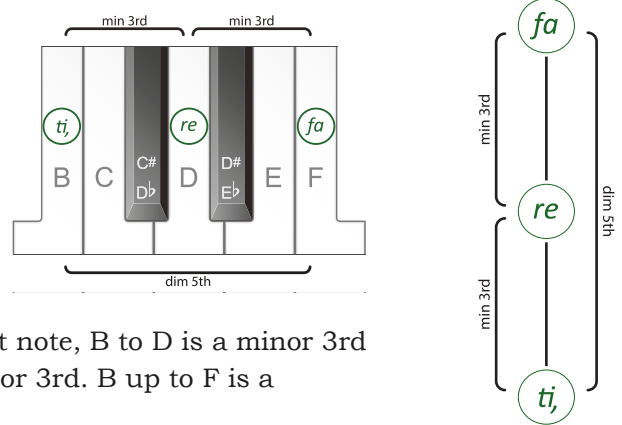

Intervals within the B Diminished Triad

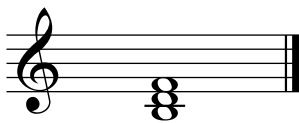

In this chord, B is the root note, B to D is a minor 3rd and D to F is another minor 3rd. B up to F is a diminished 5th.

Labelling Diminished Triads

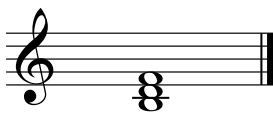

Chord Name: B diminished triad (it is the diminished triad built on B)

Roman numeral with Figures: Chord vii^o₃ in C Major or **Chord ii^o₃** in A harmonic minor (lower case Roman numeral, with the small circle, indicating the chord is diminished, Roman numeral showing the scale degree the chord is built on and the ₃ indicating that there is a 5th and a 3rd above the root note).

indicating the chord is diminished, Roman numeral showing the scale degree the chord is built on and the ₃ indicating that there is a 5th and a 3rd above the root note).

Diminished Triads - in Major and Minor Keys

Diminished triads can be built on the 7th scale degree of a Major scale:

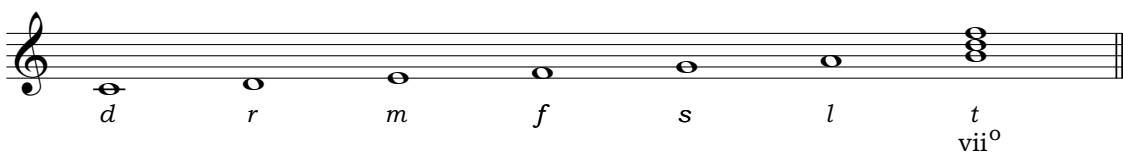

f
r'
t
vii ^o

and on the 2nd and 7th scale degrees of a harmonic minor scale:

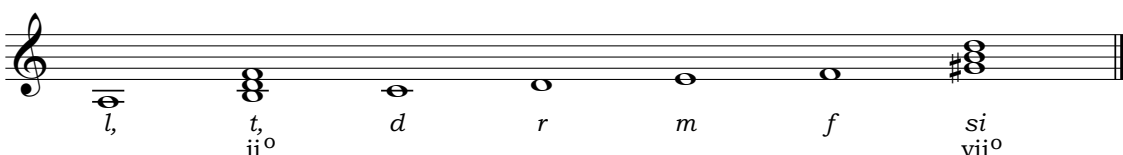

f	r'
r	t
t, si	
ii ^o	vii ^o

B Diminished Triad Melodically

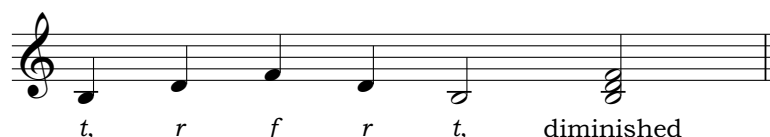



Intervals in the (B) Diminished Triad

t, r f t t f r t, diminished t r minor 3rd,

r f minor 3rd, f t Augmented 4th, t, f diminished 5th t, t Perfect 8ve



Worksheet 35

S6 Chords 1 Write a diminished triad above each given note.

S6 Chords 2 Write a diminished triad above each given note.

S6 Chords 3 Using the given notes as the **TOP** notes of each triad, write a Major triad below each note.

S6 Chords 4 Using the given notes as the **TOP** notes of each triad, write a minor triad below each note.

S6 Chords 5 Write the triad built on the **leading note** of each of the following keys. Remember to use a raised 7th in a harmonic minor key

C Major

G minor

B Major

B minor

S6 Chords 6 Five triads will be played. They will be either Major, minor or diminished triads. Write the quality of each triad in the spaces provided.

1/91

1.

2.

3.

4.

5.

Section 6 - Chord Progressions



Root Position Triads in Major Keys

Take the notes of the C Major scale and, using only notes belonging to C Major, add notes a 3rd and a 5th above each scale note. The result is all the root position triads in C Major.

Root Position Triads in the C Major Scale

d I *r* ii *m* iii *f* IV *s* V *l* vi *t* vii^o



Root Position Triads in the C Major Scale (Melodically)

Sing all the triads found in a Major scale, melodically (as follows).

d m s m d I Major, *r f l f r* ii minor, *m s t s m* iii minor, *f l d' l f* IV Major, etc

The following grid is the same as the example on the above staff in chart form. The Roman numeral indicates the scale degree of the chord and the quality (Major, minor or diminished). The root note of each chord is in italics, bold and highlighted. Sing this chart vertically, in the same way as you sang the previous exercise (i.e. all the triads in a Major scale, melodically).



Root Position Triads in the Major Scale (Chart Form)

<i>s</i>	<i>l</i>	<i>t</i>	<i>d'</i>	<i>r'</i>	<i>m'</i>	<i>f</i>
<i>m</i>	<i>f</i>	<i>s</i>	<i>l</i>	<i>t</i>	<i>d'</i>	<i>r'</i>
<i>d</i>	<i>r</i>	<i>m</i>	<i>f</i>	<i>s</i>	<i>l</i>	<i>t</i>
I	ii	iii	IV	V	vi	vii ^o



Worksheet 36

S6 Recognition of a Chord Progression A harmonic minor chord progression will be played three times. All chords are in root position. Choose and circle the progression you hear from one of the following options:

- a. I - IV - V - I b. I - ii - V - I c. I - vii^o - V - I
 d. I - vi - IV - V e. I - ii - IV - V f. I - V - vi - V

Section 6 - Revision & Practice Questions

Theory Revision

W

S6 Rhythm Rewrite this rhythm with correctly grouped notes.

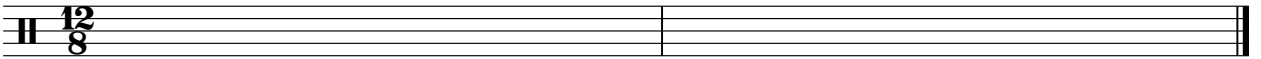

W

S6 Chords Write the following chords in D Major using accidentals.

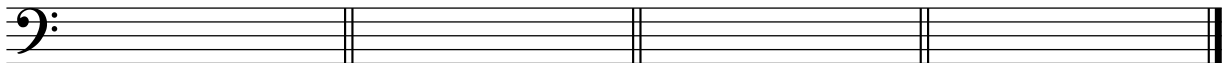

W

S6 Chord Progressions Write all the root position triads in F Major on the given staff. Use a key signature and label each with a Roman numeral showing the scale degree the chord is built on and the quality.

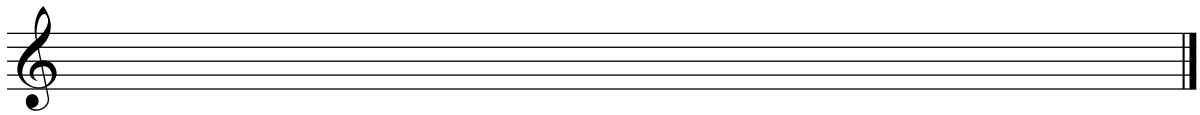

P

Musicianship Practice - Practice each task as many times as possible

PRACTICE ACTIVITIES

- Read rhythms in rhythm names while conducting
- Compose compound rhythms then read in rhythm names while conducting
- Sing the Major, natural, harmonic and melodic minor scales in solfa with handsigns
- Sing the Major, natural, harmonic and melodic minor scales in letter names in various keys up to 2# and bs
- Write the Major, natural, harmonic and melodic minor scales in treble or bass clef in various keys
- Sing the consecutive intervals within all known scales.
- Sing melodic minor melodies in solfa with handsigns
- Compose melodic minor melodies then sing in solfa with handsigns
- Sing the diminished triad naming the consecutive intervals in solfa with handsigns
- Sing Major, minor and diminished chords with intervals in solfa with handsigns
- Sing "Root Position Triads in the Major Scale" in solfa with handsigns (page 79)

Section 7 - Rhythm



More Semiquavers in Simple Time



In simple time, there are several combinations of two semiquavers and one quaver lasting for one crotchet beat.

This combination has the long sound (the quaver) at the start of the beat.

Read Rhythmic Example 30 while clapping this ostinato taking note of where, in the ostinato, the first quaver of this new rhythm falls.



sounds the same as



Rhythmic Example 30

ti - ti-ka ti - ti-ka etc



More Semiquavers in Simple Time



This combination of two semiquavers and one quaver has the long sound (the quaver) on the second half of the beat.

Read Rhythmic Example 31 while clapping this ostinato: taking note of where, in the ostinato, the quaver of this new rhythm falls.



sounds the same as



Rhythmic Example 31

ti-ka ti ti-ka-ti etc



Rhythmic Example 32

New Rhythmic Shorthand

By this stage you should be comfortable using rhythmic shorthand, perhaps beginning to alter the examples given in this book to suit the way you hear the rhythms.

This rhythmic shorthand will become a valuable tool as the rhythms become more complicated. For example, these new rhythms can be shown using rhythmic shorthand in at least these two ways:

ti - ti-ka or ti - ti-ka ti-ka ti or ti-ka ti

ti-ka ti sounds the same as ti-ka-ti which is why reflects what is heard for this rhythm.

Four Step Rhythm Practice Activity

The following four steps can be used to practice any rhythmic exercise:

1. Tap or conduct the beat and read the rhythm names;
2. Tap the pulses (clap the strong pulse, tap any weak pulses) and read the rhythm names;
3. Count the beat (1, 2, 3) and clap the rhythm;
4. Count the pulses (Simple time: 1 & 2 & or Compound time: 1 & a, 2 & a) and clap the rhythm.



Worksheet 37

Write a rhythm set and shorthand for each of these transcriptions. There are no rests in these transcriptions.

S7 Rhythmic Transcription 1

† = † = † | | | † | - † | | |

1/93

S7 Rhythmic Transcription 2

| | - † | - † | | | | | |

1/94

S7 Rhythmic Transcription 3

1/95

S7 Rhythmic Transcription 4

1/96

Section 7 - Scales

Aural Tonality Recognition - Major or Minor?



Practice Question 13: Aural Tonality Recognition (Part A) - Major or Minor?

A melody will be played several times.

The tonality of this melody will be either: **MAJOR** or **MINOR**

Determine the tonality of the melody and circle this above.

As you listen to the melody, follow these instructions:

1. Consider the main differences between the two tonalities given: **Major** and **minor**, using the tone ladders provided. As you are not required to determine **which** minor scale the melody is based on, the minor tone ladder is shown with the raised 6th (*fi*) and 7th (*si*) as well as the natural *fa* and *so*. Sing these scales in solfa with handsigns.
2. The first time you hear the melody decide what the last note sounds like in solfa: *do* or *la*. Patterns such as *mi re do* or *so la ti do'* in Major and *do ti, la*, or *mi fi si la* in minor can give clues towards the ending.

In this melody the last note is *la*. The last few notes point strongly to this: *do ti, la, si, la,*. The tonic note of a minor scale is *la*. *la* is also frequently repeated throughout this melody.

Consider other aspects such as whether any tonic/dominant/patterns/runs etc can be heard.

In bars 3 and 4 there is an almost complete descending (harmonic) minor scale: *la si fa mi do ti, la*, with *fa* to *si* highlighting the **Augmented 2nd** while in bar 6 there is part of an ascending minor scale: *la, ti, do re mi* and in bar 7 there is part of a descending minor scale: *mi re do ti, la, si, la,*. Also, bar 1 contains the notes *la, do mi*. These notes form the tonic triad (chord i) in a minor scale.

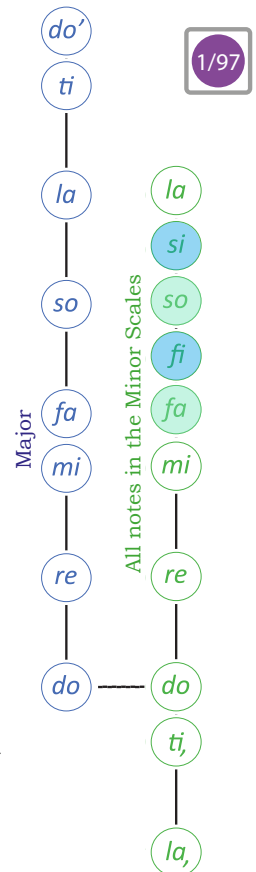

Practice Question 13: Aural Tonality Recognition (Part B) - Which Minor?

When asked to choose **which** minor tonality a melody is based on:

NATURAL MINOR or **HARMONIC MINOR** or **MELODIC MINOR**

listen for the differences that occur between the three forms of the minor scale.

For example, in the previous exercise there were many instances of *fa* to *si* (the **Augmented 2nd** found **only** in the harmonic minor scale). While not being fully conclusive (you can have both *fa* and *si* in a **melodic** minor scale) it is most likely that this melody is based on the **harmonic** form of the minor scale.

Therefore,

- if the melody has **no** raised 6th (*fi*) or 7th (*si*) notes at all it most likely uses the **natural** form of the minor;
- if the melody has a **raised 7th** (*si*) every time this note is played then it most likely uses the **harmonic** form of the minor however;
- if the melody **sometimes** has a raised 6th (*fi*) and 7th (*si*) and sometimes the natural version of these notes (*fa* and *so*) then the melody **is** in the **melodic** form of the minor.

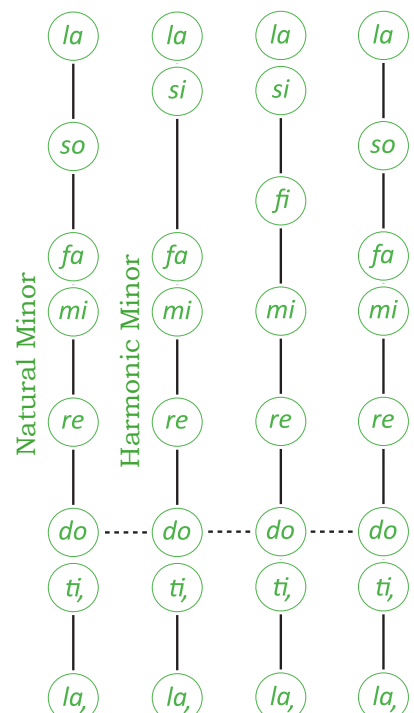

Worksheet 38

S7 Aural Tonality Recognition Instructions

Listen to the following melodies which will be played three times each.
Circle the correct tonality of each melody.

S7 Aural Tonality Recognition 1**MAJOR**

or

MINOR

1/98

S7 Aural Tonality Recognition 2**MAJOR**

or

MINOR

1/99

S7 Aural Tonality Recognition 3**MAJOR**

or

MINOR

2/01

S7 Aural Tonality Recognition 4**NATURAL MINOR**

or

MELODIC MINOR

2/02

S7 Aural Tonality Recognition 5**HARMONIC MINOR**

or

MELODIC MINOR

2/03

S7 Scales 1 Beginning on, and using the note value of, the given note, write the ascending and descending melodic minor scale using a key signature. Write the solfa beneath each note.

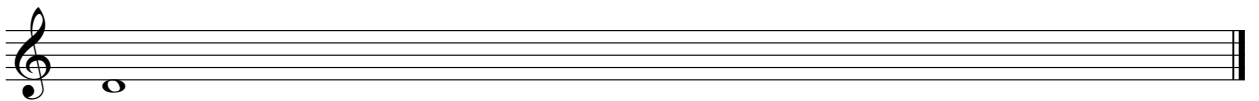

S7 Scales 2 Write the key signatures of the following scales.

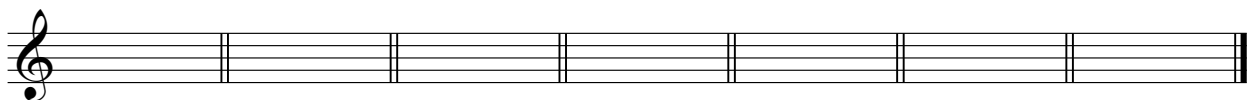

$E\flat$ Major F minor $D\flat$ Major D Major C minor $A\sharp$ minor C Major

S6 Scales 3 Complete the following chart.

Number of sharps in key signature	Name of sharps (in key signature order)	Tonic note of Major scale	Tonic note of minor scale
2	F \sharp C \sharp	D	B
4			
6			
3			
5			
1			
7			

Section 7 - Intervals



Worksheet 39

S7 Intervals 1 Write a tritone above each of the following notes.

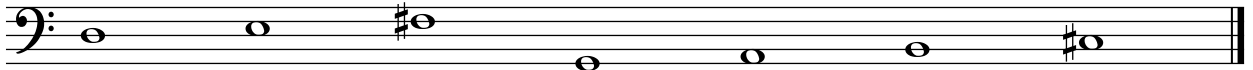

S7 Intervals 2 Write a Major 3rd below each of the following notes.

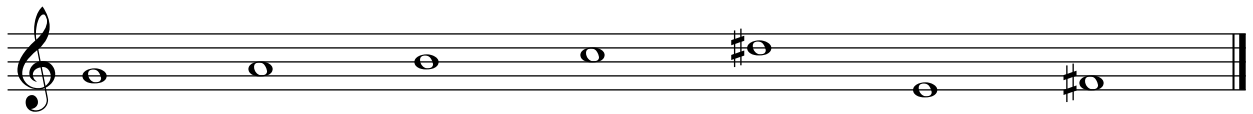

S7 Intervals 3 Identify the bracketed intervals in the following two melodies. Write your answers (quality and number) beneath the brackets.

1.

2.

S7 Intervals 4 Intervals will be played twice. Name the intervals you hear.

2/04

1. _____ 2. _____ 3. _____ 4. _____ 5. _____ 6. _____

S7 Intervals 5 A melody will be played several times. The rhythm of this melody is printed below. Identify the first and last intervals (quality and number) and write your answers beneath the brackets and circle the tonality of the melody below.

2/05



Scale form: Major Harmonic minor Melodic minor

Section 7 - Melody



Practice Question 14: Three Part Melodic Transcription

1. Study the melodic transcription below.

Use the flow chart on page 60 to determine the key of this melody.

There are no sharps or flats in the key signature. This tells us that C is *do*. The bass (**lowest**) part ends on a C or *do*, therefore this example is in the key of C Major. Write the C Major scale on this staff with solfa and letter names beneath each note:

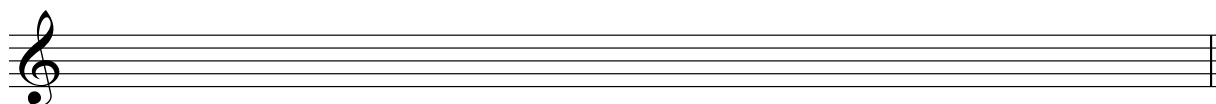

2. Sing this scale in solfa and letter names.
3. The melody for Practice Question 14 will be played several times. Before it begins, note the rhythm given above the staff. This is the rhythm of the melody. The solfa of the first note is written under this rhythm.
4. Study the three parts below. (Some transcription exercises may have instrument names which may help identify parts). Sing them (either out loud or in your head) in solfa. Also look at the given parts from a harmonic perspective. Writing in the solfa for these other parts can help identify likely melodic pitches.
The first time you hear the melodic transcription listen and point to the rhythm above the staff. If you **recognise** any notes (such as the tonic: *do* or the dominant: *so*) write the solfa of these notes under the rhythm where you heard them. You may remember the solfa of the last few notes as these will remain in your internal memory. Use the scale you have written (or a solfa tone ladder such as the Major one on page 4) to point to and help recognise notes.
5. Use further playings of the melodic transcription to continue writing the solfa you hear under the rhythm. When you are (fairly) sure your solfa is correct write this as notes on the staff. (Do not leave this until the end as looking at the notes written on the staff can help find mistakes).
6. Complete your transcription on the staff before the final playing. Use the final playing to check your completed melody by singing it in solfa in your head and pointing to the notes as you listen.

Melodic Transcription

Use this process for **all melodic transcription** exercises.

In particular, write the transcription scale (the scale the transcription is based on) with the solfa and letter names below for **every** exercise. Where necessary, use manuscript or draw your own staff to write key information on.

S7 Melodic Transcription 1

2/07

S7 Melodic Transcription 2

2/08

S7 Melodic Transcription 3

2/09

S7 Melody Determine if the following melodic fragments are in a Major or minor tonality and circle the correct option.

MAJOR or MINOR

MAJOR or MINOR

Section 7 - Chords



Blank area for student work.

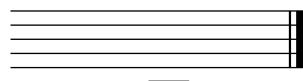
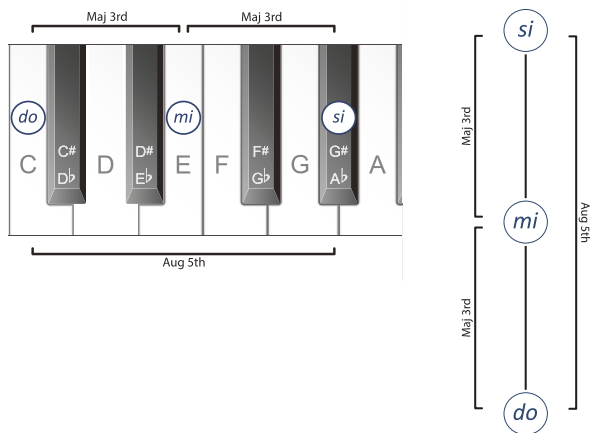

Blank area for student work.

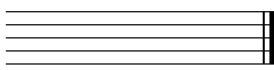

III

Blank area for student work.



III



Blank area for student work.





Worksheet 41

S7 Chords 1 Write an Augmented triad on each given note.

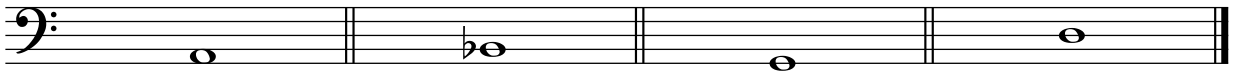

S7 Chords 2 Write an Augmented triad on each given note.

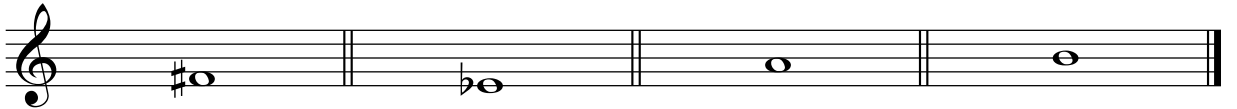

S7 Chords 3 Using the given notes as the **TOP** note of each triad, write a diminished triad below each note.

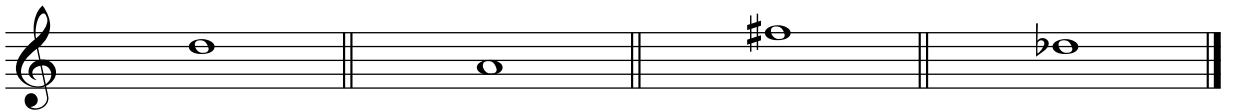

S7 Chords 4 Name the minor key that each of the following dominant triads belongs to.

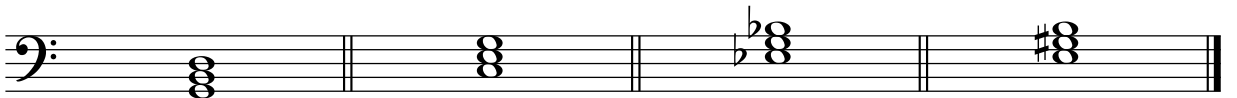

S7 Chords 5 Write the following triads in the Major keys with these key signatures.



mediant

dominant

supertonic

tonic

S7 Chords 6 Write the triad built on the **dominant** of each of the following keys using accidentals.



F Major

B minor

C# minor

G Major

S7 Chords 7 Five triads will be played twice. They will be either Major, minor, diminished or Augmented triads. Write the quality of each triad in the spaces provided.

2/10

1.

2.

3.

4.

5.

Section 7 - Chord Progressions



Root Position Triads in Minor Keys



Take the notes of the A harmonic minor scale and, using only notes belonging to A harmonic minor, add notes a 3rd and a 5th above each scale degree. The result is all the root position triads in A harmonic minor.

Root Position Triads in the A Harmonic Minor Scale

l, *t* *d* *r* *m* *f* *si*
i *ii*^o *III*⁺ *iv* *V* *VI* *vii*^o



Root Position Triads in the (A) Harmonic Minor Scale (Melodically)

Sing all the triads found in the harmonic minor scale, melodically (as follows) taking note of the root (bottom) note of each chord.

l, *d m d l*, *i* minor, *t, r f r t*, *ii* diminished, *d m si m d* *III*⁺ Augmented, etc

The following grid is the same as the example on the above staff in chart form. The Roman numerals show the scale degree of the chord and quality (Major, minor, diminished or Augmented). The root note of each chord is in italics, bold and highlighted. Sing this chart vertically, in the same way as you sang the previous exercise (i.e. all the triads in a harmonic minor scale, melodically).



Root Position Triads in the Harmonic Minor Scale (Chart Form)

<i>m</i>	<i>f</i>	<i>si</i>	<i>l</i>	<i>t</i>	<i>d'</i>	<i>r'</i>
<i>d</i>	<i>r</i>	<i>m</i>	<i>f</i>	<i>si</i>	<i>l</i>	<i>t</i>
<i>l</i> ,	<i>t</i> ,	<i>d</i>	<i>r</i>	<i>m</i>	<i>f</i>	<i>si</i>
<i>i</i>	<i>ii</i> ^o	<i>III</i> ⁺	<i>iv</i>	<i>V</i>	<i>VI</i>	<i>vii</i> ^o



Worksheet 42

S7 Chord Progression Using Roman numerals, identify the chords in this progression. The first chord has been given. Identify the cadence created by the last two chords.

1. *i*

2.

3.

4.

Cadence: _____

Worksheet 42 cont.

S7 Recognition of a Chord Progression A harmonic minor chord progression will be played three times. All chords are in root position. Circle the correct option.
The chord progression will be one of the following:

2/12

- a. i - iv - V - i b. i - VI - iv - V c. i - ii^o - iv - V
d. i - III⁺ IV - V e. i - V - ii^o - V f. i - V - VI - V

S7 Chord Progressions 1 Write all the root position triads in B harmonic minor on the given staff. Use a key signature and label each with a Roman numeral showing the scale degree the chord is built on and its quality.

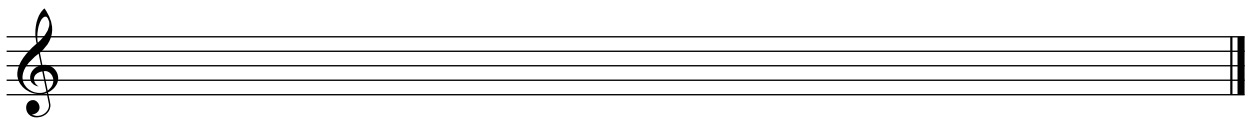

S7 Chord Progressions 2 Write all the following root position triads in G harmonic minor using accidentals.

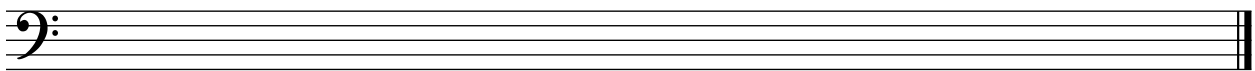

ii^o iv vii^o i V III⁺ VI

S7 Chord Progressions 3 Write all the following root position triads in A Major using a key signature.

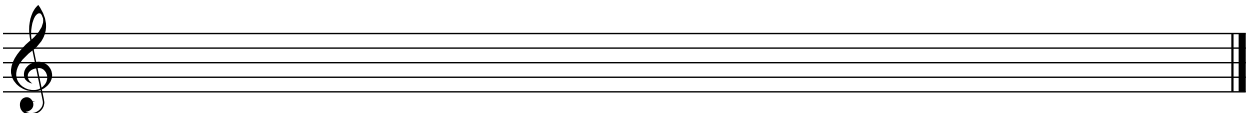

ii V vii^o vi iii IV I

S7 Chord Progressions 4 Complete the following chord charts.

<i>s</i>		<i>t</i>	<i>d'</i>		<i>m'</i>	<i>f</i>
<i>m</i>	<i>f</i>		<i>l</i>	<i>t</i>		<i>r'</i>
<i>d</i>		<i>m</i>			<i>l</i>	
I	ii			V		

<i>m</i>	<i>f</i>			<i>t</i>	<i>d'</i>	
<i>d</i>		<i>m</i>				
<i>l,</i>	<i>t,</i>		<i>r</i>	<i>m</i>	<i>f</i>	<i>si</i>
i		III ⁺	iv			vii ^o

Section 7 - Revision & Practice Questions

Theory Revision

W

S7 Rhythm Complete each bar by adding notes as specified.

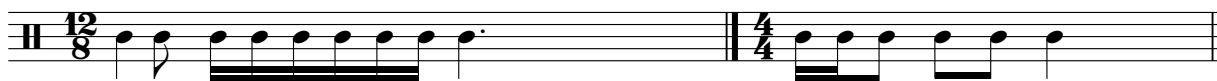

Two semiquavers and two quavers

Two semiquavers and one quaver

W

S7 Scales Complete the following chart.

Major Scale	No of Sharps	Relative Minor Scale	Raised 7th note
C Major	0	A minor	G#
	2		
		G# minor	
			D#
F# Major			
	7		
		C# minor	
			E#

P

Musicianship Practice - Practice each task as many times as possible

PRACTICE ACTIVITIES

- Read rhythms in rhythm names while clapping an ostinato and walking the beat
- Compose rhythms (using new rhythms) then read in rhythm names while conducting
- Sing the Major, natural, harmonic and melodic minor scales in solfa with handsigns, inner hearing all dominant notes
- Sing the Major, natural, harmonic and melodic minor scales in letter names in various keys up to 3# and bs
- Write the Major, natural, harmonic and melodic minor scales in treble or bass clef in various keys
- Sing all Major & minor 3rds belonging to the melodic minor scale, in solfa with handsigns
- Sing melodic minor melodies in solfa with handsigns
- Compose melodic minor melodies then sing in solfa with handsigns
- Sing the Augmented triad naming the consecutive intervals in solfa with handsigns
- Sing Major, minor, diminished and Augmented chords with intervals in solfa with handsigns
- Sing "Root Position Triads in the Harmonic Minor Scale" in solfa with handsigns (page 90)

Section 8 - Rhythm



Yet More Semiquavers in Compound Time



These rhythms are combinations of four semiquavers and one quaver commonly found in compound time.

ti-ka-ti-ka-ti

ti - ti-ka-ti-ka

ti-ka-ti - ti-ka

These rhythms are worth one dotted crotchet beat (equal to three quaver pulses) in compound time.



Rhythmic Example 33

ti - ti - ti ti-ka-ti-ka-ti ti ta etc



Rhythmic Example 34

ta ti ti - ti-ka-ti-ka ti - ti-ka-ti-ka ti ta etc



Rhythmic Example 35

ti-ka-ti - ti-ka ti - ti - ti etc



Crotchet/Semiquaver Combinations in Compound Time



Possible one beat combinations of one crotchet and two semiquavers in compound time are:

ta ti ka

and

ti ka ta

These rhythms are a combination of unequal sounds with long and short sounds mixed together. Determining where the longer and shorter notes are can help with recognition of these rhythms.

These rhythms are also worth one dotted crotchet beat (equal to three quaver pulses) in compound time.



Rhythmic Example 36



Rhythmic Example 37



Rhythmic Example 38



Worksheet 43



Write a rhythm set and shorthand for each of these transcriptions. There are no rests in these transcriptions.

S8 Rhythmic Transcription 1

2/13

S8 Rhythmic Transcription 2

2/14

Worksheet 43 cont.

S8 Rhythmic Transcription 3

2/15

S8 Rhythmic Transcription 4

2/16

S8 Rhythmic Recognition

2/17

A

B

C

D

S8 Rhythm Compose four bars of compound duple time rhythm using as many different known rhythms as possible. Include at least one of each of the new rhythms taught in this section. Perform your rhythm by reading the rhythm names while conducting.

Section 8 - Scales



The Chromatic Scale

The **chromatic scale** is made up of all 12 notes (not including the top octave repeated note) within one octave (white and black keys) on the piano. The interval between every consecutive pair of notes is a semitone.

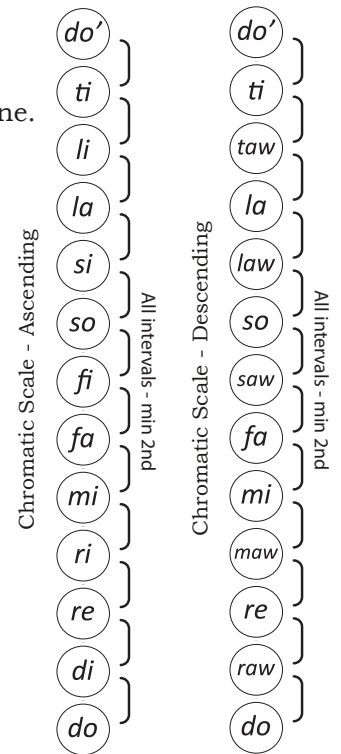
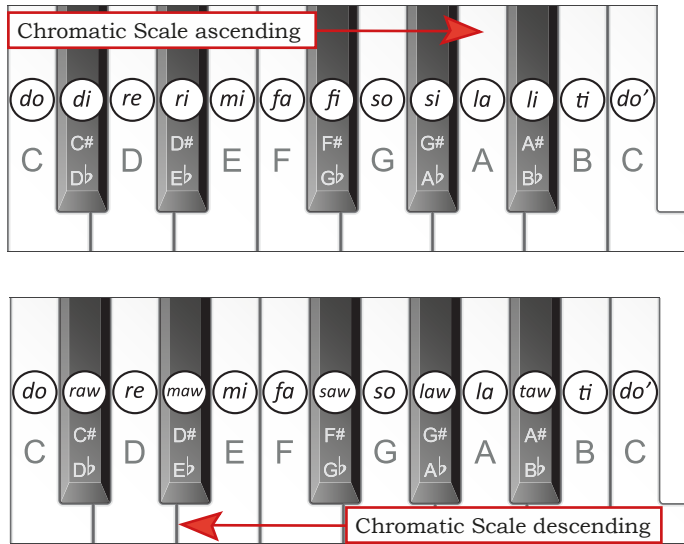

Although the chromatic scale has been notated in three different ways below, they all **sound** the same.

Writing the Chromatic Scale

The most common way to write a **chromatic scale** is to use **sharps** for the **ascending** form and **flats** for the **descending** form.

The Chromatic Scale

Writing the Harmonic Chromatic Scale

Another way of notating a chromatic scale (called the **harmonic chromatic scale**) is to write all the notes from the Major, harmonic minor and melodic minor scales belonging to the starting pitch plus a lowered 2nd and raised 4th. In the following scale, C is the starting note. So you would include:

- all the notes from C Major,
- the additional notes from C harmonic minor (E \flat and A \flat),
- the additional note from C melodic minor (A \sharp)
- plus the lowered 2nd (D \flat) and raised 4th (F \sharp).

This scale will be the same ascending and descending.

The Harmonic Chromatic Scale

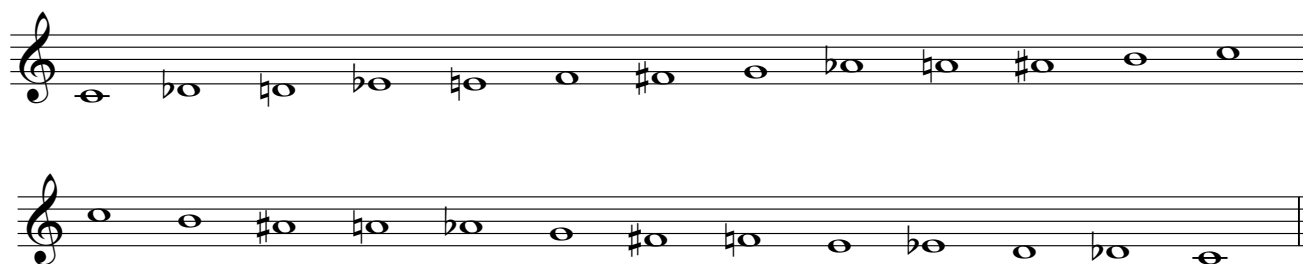

Writing the Intervallic Chromatic Scale

Writing the notes of a chromatic scale so that all possible "diatonic" intervals (see page 62) are created from the bottom note will form another type of chromatic scale notation. In the following scale the intervals created from the bottom note are:

- a minor 2nd (C to D \flat),
- a Major 2nd (C to D),
- a minor 3rd (C to E \flat),
- a Major 3rd (C to E),
- a Perfect 4th (C to F)
- an Augmented 4th OR diminished 5th etc.

This scale will also be the same ascending and descending.

The Intervallic Chromatic Scale

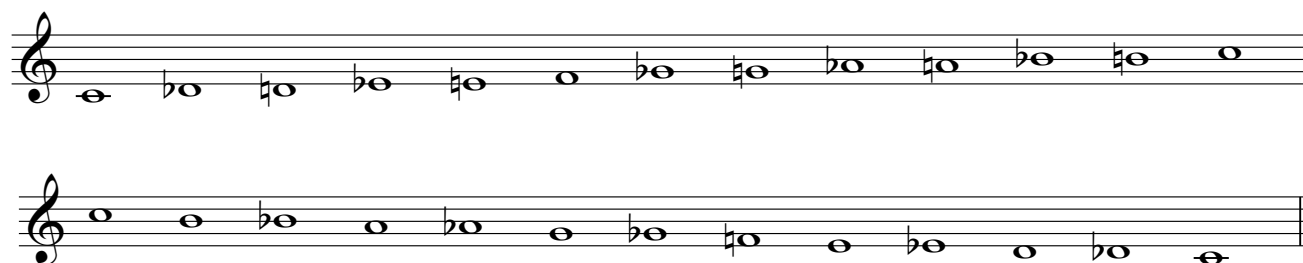

A chromatic scale **does not** have a key signature and there is **no tonal centre** (due to the fact that the interval between every pair of notes is the same).

The chromatic scale can begin and end on **any** of its 12 notes.

Music written using the chromatic scale as its basis is often referred to as **atonal** music meaning **not in any key** or music without a tonal centre.

W

Worksheet 44

Use whichever form of the chromatic scale you prefer when writing the following scales.

S8 Scales 1 Write a chromatic scale, ascending and descending, beginning on C.

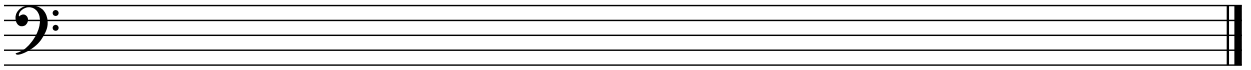
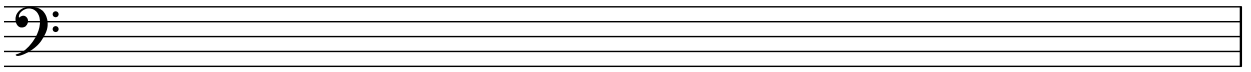

S8 Scales 2 Write a chromatic scale, ascending only, beginning on, and using the value of, the given note.

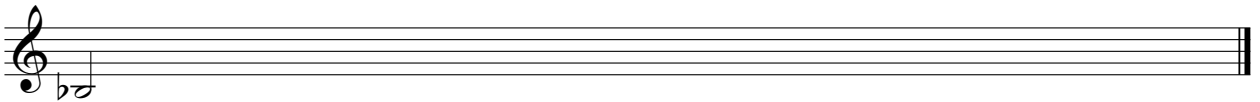

S8 Scales 3 Write a chromatic scale, descending only, beginning on, and using the value of, the given note.

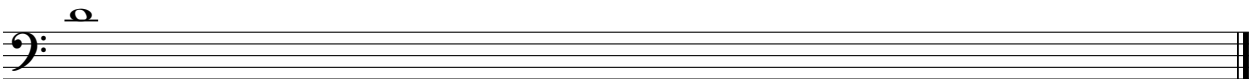

S8 Scales 4 Write a chromatic scale, descending then ascending, beginning on F#.

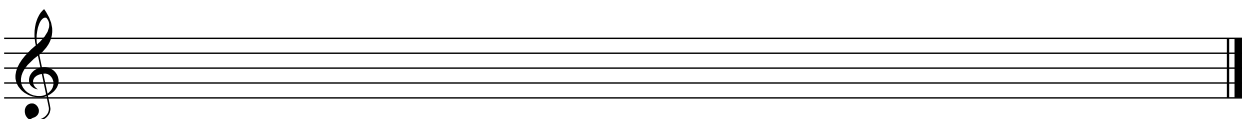
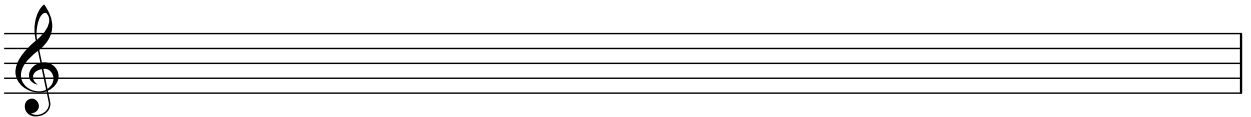

S8 Key Recognition Write the tonality (key) for the following melody in the space provided. List three elements in each melody that indicate this choice. The melodies may be either Major, natural minor, harmonic minor or melodic minor.



Tonality:

Element 1:

Element 2:

Element 3:

Section 8 - Intervals

Intervals within the Chromatic Scale

The interval between every consecutive pair of notes in a chromatic scale is a semitone or minor 2nd.

C Chromatic Scale Interval Pattern

minor 2nd minor 2nd
semitone semitone etc

I Interval Practice

There are many ways to practise intervals. So far we have practised singing:

- Major and Perfect Intervals
- minor and Perfect Intervals
- Perfect and Augmented 4ths
- Consecutive intervals within known scales

It is also helpful, particularly for melodic transcription exercises, to sing all the possible intervals found within various scale types. For example, the following exercise shows how to practise 3rds found in a Major scale.

3rds in a Major Scale

do mi Ma-jor third, re fa mi-nor third, mi so mi-nor third, fa la Ma-jor third, etc

Interval Lines

Interval lines are another way of practising **abstract** intervals (intervals not in a melody). Sing each interval line by beginning on the given solfa note then singing the note you will reach by singing the interval given in the direction of the arrow.

If sung correctly an interval line should begin and end on the same note. For example, this interval line would be sung in the manner shown on the staff that follows:

Interval Line 1

do ↑ ↑ ↓ ↑ ↑ ↑ ↓ ↑ ↓ ↓
M2 M2 M3 M3 m2 M2 P5 P5 m3 M3

Interval Line 1 on the Staff

do re Maj-or se-cond, re mi Maj-or se-cond, mi do Maj-or third, do mi Maj-or third, etc

Interval Line 2

$la,$ \uparrow \uparrow \uparrow \uparrow \uparrow \downarrow \downarrow \downarrow \uparrow \downarrow
 m3 M3 M2 M2 m2 M3 m3 P4 P5 P5

Worksheet 45

S8 Intervals 1 A melody will be played several times. The rhythm of this melody is printed below. Identify the first and last intervals (quality and number) and write your answers beneath the brackets and circle the tonality of the melody below.

2/18



Scale form: Major Harmonic minor Melodic minor natural minor

S8 Intervals 2 Write these intervals below the given notes.

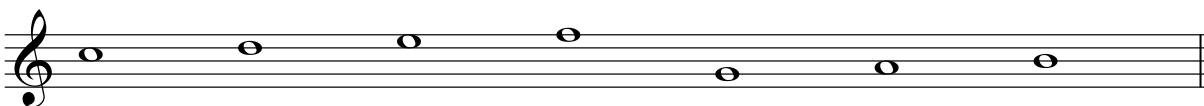

minor 7th Major 3rd Perfect 5th Perfect 5th Major 3rd Major 6th minor 2nd

S8 Intervals 3 Write a Major 2nd below each of the following notes.

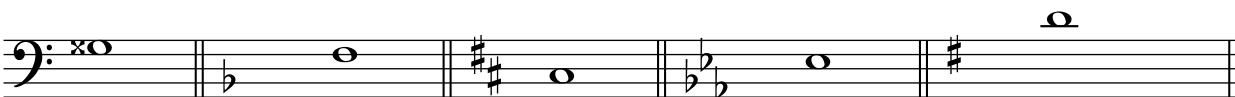

S8 Intervals 4 Name these intervals.



S8 Intervals 5 Identify the bracketed intervals in the following melody. Write your answers (quality and number) beneath the brackets. (This melody does not have a key signature and uses many notes of the chromatic scale).



S8 Intervals 6 Six intervals (Major, minor, Perfect and the tritone) will be played twice. Name the intervals you hear.

2/19

1. 2. 3. 4. 5. 6.

Section 8 - Melody



Practice Question 15: Recognition of Melody

- Practice Question 15 is a four bar, three part score with two empty bars. Below this are four two bar melodic options (labelled A. to D.) one of which will be the missing two bars of melody played. Before the first playing, study the melodic options, inner hearing them as you do, noting where they differ and where they are the same. Consider creating a map for your ears to follow.
The associated video:  *shows how to do this question type in detail.*
- Listen to Practice Question 15 and choose which melodic option is being played in the empty bars. Note the use of diagonal strokes to show the rhythm and chord names to show the chords the second part must play.
- Circle the correct melody.

Melodic Recognition

2/20



Worksheet 46



S8 Melodic Recognition 1

2/21

Worksheet 46 cont.

S8 Melodic Recognition 2

Bassoon

2/22

A B C D

S8 Melodic Recognition 3

2/23

A B C D E F

S4 Melodic Composition Create a melody in B melodic minor by writing the rhythm on the rhythm staff, the solfa underneath this rhythm and then transferring this onto the treble staff below. Sing in solfa and in letter names once you have finished.

Section 8 - Chords

Suspension

- A **suspension** is created when a note from a previous chord is held over into the following chord, causing a clash, a discord, in harmony (usually a 2nd), which causes tension.
- This tension is usually resolved when the suspended note falls to the note that belongs to the second chord.

In this example we have a triad with a suspended 4th (the middle note, F, in the first triad).

C sus 4 C Major triad

This suspended note then resolves by falling to the E (the middle note in the second triad) creating a C Major triad. The first triad is therefore known as a C Major triad with a suspended 4th or C sus4.

The Suspended 4th Chord

- A suspended 4th chord (in root position) is made up of a root note, a note a Perfect 4th and a note a Perfect 5th above the root note.

Intervals within the C Suspended 4th Chord

In this chord, C is the root note, C to F is a Perfect 4th and F to G is a Major 2nd. C up to G is a Perfect 5th.

It is the interval between the upper two notes (a Major 2nd) that creates the tension referred to above. **Suspended 4th chords** can be created on the 1st, 2nd, 3rd, 5th and 6th scale degrees in a Major Scale and on the 1st and 5th scale degrees in a harmonic minor scale.

C Suspended 4th Chord Melodically

d f s f d Suspended 4th

Intervals in the (C) Suspended 4th Chord

d f s d' d' s f d Suspended 4th d f Perfect 4th, 4th

f s Major 2nd, s d' Perfect 4th, d s Perfect 5th, d d' Perfect 8ve.

Worksheet 47

S8 Chords 1 Write a suspended 4th chord on each given note.

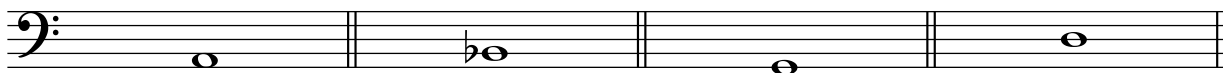

S8 Chords 2 Write a suspended 4th chord below each given note.

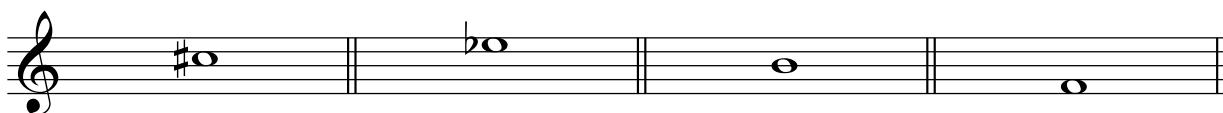

W

S8 Chords 3 In the tonic keys indicated, write and name the specified chords.

subdominant	submediant	tonic	mediant
D Major	B \flat Major	C harmonic minor	D harmonic minor

S8 Chords 4 Using the treble clef, write a tonic triad for 7 different Major keys. Use a key signature for each triad and name the key on the line below. Do not use key signatures with more than three sharps or flats.

S8 Chords 5 Complete the following chart.

Triad	The interval between the lowest two notes	The interval between the highest two notes	The quality of the 5th created by the lowest and highest notes.
Major	Major 3rd	minor 3rd	Perfect
minor			
diminished			
Augmented			
suspended 4th			

S8 Chords 6 Five triads will be played.

They will be either Major, minor, diminished, Augmented or suspended 4th triads. Write the quality of each triad in the spaces provided.

2/24

1.

2.

3.

4.

5.

Section 8 - Chord Progressions



Chord Charts for Transcriptions



Shorthand versions (for use in chord progression transcription questions) of the chord charts we have been studying are printed below - one for Major keys and one for harmonic minor keys. This version leaves out the solfa of the 3rd and 5th note of each chord but adds in the letter names of the bass notes of each possible scale degree within the key of the progression.

Major Scale Chord Progression Transcription Chart Example (F Major)

F	G	A	B \flat	C	D	E
<i>d</i>	<i>r</i>	<i>m</i>	<i>f</i>	<i>s</i>	<i>l</i>	<i>t</i>
I	ii	iii	IV	V	vi	vii $^\circ$

Minor Scale Chord Progression Transcription Chart Example (D minor)

D	E	F	G	A	B \flat	C \sharp
<i>l,</i>	<i>t,</i>	<i>d</i>	<i>r</i>	<i>m</i>	<i>f</i>	<i>si</i>
i	ii $^\circ$	III $^+$	iv	V	VI	vii $^\circ$



Worksheet 48

Write the transcription chord chart out first for all chord progression transcriptions.

Chord Progression Transcription Instructions Two chord progressions, using any root position triad found in a Major or harmonic minor scale, will be played several times. The first (tonic) chord is printed at the start of each progression. Identify the chords you hear using the harmonic grid.

S8 Chord Progression 1

2/25

Harmonic Grid 1. *d* 2. 3. 4. 5.

Bass note	D				
Quality	Major				

S8 Chord Progression 2

2/26

Harmonic Grid 1. *l* 2. 3. 4. 5.

Bass note	D				
Quality	minor				

Section 8 - Revision & Practice Questions

Theory Revision

W

S8 Theory Rewrite the following statements correctly.

$\frac{9}{8}$ can be described as compound duple time and has 3 crotchet beats per bar.

$\frac{3}{4}$ has 3 minim beats per bar. The quavers are grouped in threes.

$\frac{3}{8}$ can be described as compound triple time. The quavers are grouped in twos.

An Augmented triad has a minor 3rd between the lowest two notes, a Major 3rd between the top two notes and a Perfect 5th between the lowest and highest notes.

The only scale that has two different versions of the same note is the natural minor scale.

An Augmented 4th sounds the same as a diminished 4th.

P

Musicianship Practice - Practice each task as many times as possible

PRACTICE ACTIVITIES

- Read two part rhythms in rhythm names and perform both parts in various ways
- Compose rhythms (using new rhythms) then read in rhythm names while conducting
- Sing the Major, natural, harmonic and melodic minor scales in solfa with handsigns, in a 123, 234, 345 sequence.
- Sing the Major, natural, harmonic and melodic minor scales in letter names in various keys up to 4# and bs
- Write the Major, natural, harmonic and melodic minor scales in treble or bass clef in various keys
- Sing interval lines, in solfa with handsigns
- Sing Major and melodic minor melodies in solfa with handsigns
- Compose Major and melodic minor melodies then sing in solfa with handsigns
- Sing the Suspended 4th chords naming the consecutive intervals in solfa with handsigns
- Sing Major, minor, diminished, Augmented and Suspended 4th chords with intervals in solfa with handsigns
- Sing "Root Position Triads in the Major Scale" in solfa with handsigns (page 79)
- Sing "Root Position Triads in the Harmonic Minor Scale" in solfa with handsigns (page 90)

Section 9 - Rhythm



The Dotted Quaver in Simple Time

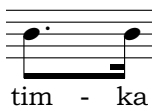

This new rhythm is a longer note (a dotted quaver lasting for three quarters of a beat) followed by a shorter note (a semiquaver lasting for one quarter of a beat). These two sounds lasts for one crotchet beat in total.

Read Rhythmic Example 39 while clapping this ostinato:  taking note of where, in the ostinato, the semiquaver in this new rhythm falls.

The rhythm of the ostinato is written above the Rhythmic Example below.

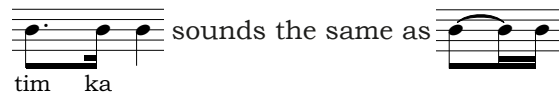

Rhythmic Example 39

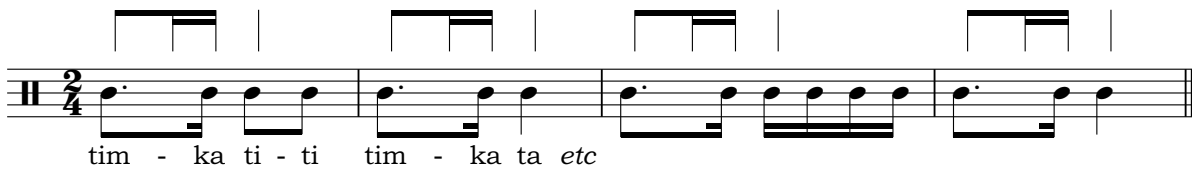

The dotted quaver/semiquaver rhythm is often used reversed and also lasts for one crotchet beat in total.

Read Rhythmic Example 40 while clapping this ostinato:  taking note of where, in the ostinato, the notes in this new rhythm fall.

The notes of the ostinato are written above the Rhythmic Example below.

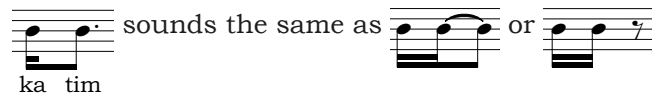

Rhythmic Example 40

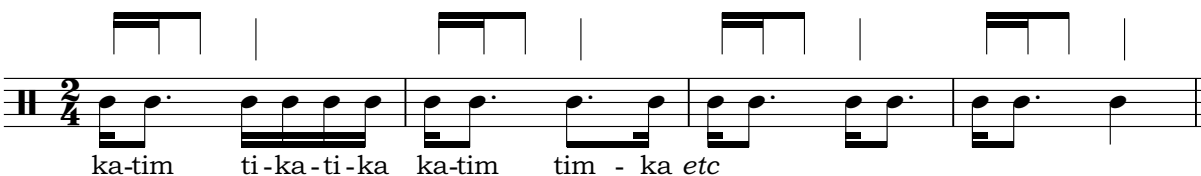



Cut Common Time



This is the symbol used to show **cut common time**.

The most frequently used cut common time signature is 

This time signature has two minim or half note beats per bar and can be described as **simple duple time**. The  at the top means there are two beats per bar and the  at the bottom means these beats are half note or minim beats.



Rhythmic Example 41

A musical staff in common time (C) showing four measures of rhythmic notation. The notes and rests are: 1. Quarter, Quarter, Half. 2. Quarter, Quarter, Quarter, Quarter, Half. 3. Quarter, Quarter, Quarter, Quarter, Quarter, Quarter, Quarter, Quarter, Half. 4. Half, Half.



Two Part Rhythm

Perform this two part rhythm, tapping the top part with your right hand (using a pen to tap will give a different timbre to the other part) and the lower part with your left hand.

Two musical staves in 2/2 time. The top staff contains: Quarter, Quarter. The bottom staff contains: Quarter, Quarter.



Worksheet 49

Write a rhythm set and shorthand for each of these transcriptions. There are no rests in these transcriptions.

S9 Rhythmic Transcription 1

Shorthand notation above a staff in 3/4 time: + - ≠ + | | | + | - ≠ | | |. The musical notation below shows: Quarter, Quarter.

2/27

S9 Rhythmic Transcription 2

Musical notation on a staff in common time (C). The notes and rests are: Quarter, Quarter.

2/28

S9 Rhythmic Transcription 3

Shorthand notation above a staff in 2/2 time: + | - ≠ + | | | | | | | | | | ≠ +. The musical notation below shows: Quarter, Quarter.

2/29

S9 Rhythmic Transcription 4

Piano. Musical notation in treble and bass clefs, 2/4 time. The notes and rests are: Quarter, Quarter.

2/30

Worksheet 49 cont.

S9 Rhythmic Transcription 5

Note that a percussion clef (seen below for the conga) does not show actual pitch instead it shows which drum to use.

Flute

Bassoon

Conga

2/31

S9 Rhythmic Transcription 6

Guitar

Bass Guitar

Tom-toms

2/32

S9 Rhythmic Transcription 7

2/33

S9 Rhythmic Transcription 8

Taiko
Drums

Xylophone

2/34

S9 Rhythm Add barlines to the following rhythms.

Section 9 - Scales



The Pentatonic Scales

A **pentatonic scale** is a scale with five notes (from the Greek word: pente, meaning five).

This scale is frequently heard in Scottish Music (such as "Auld Lang Syne") and in the music of cultures such as China, Thailand and some parts of Africa. In Western Music, the pentatonic scale gained importance during the Impressionist Era with composers such as Debussy using it in their compositions.

The pentatonic scale discussed in this text contains no intervals of a semitone (there is no *fa* or *ti*). These are called anhemitonic (meaning a type of scale with no semitones) pentatonic scales.

The Major or *do* Pentatonic Scale

The **Major pentatonic scale** is a five note scale in which *do* is the tonic.

This scale uses the same notes as a Major scale but without the 4th (*fa*) or the 7th (*ti*). This creates a scale with no semitones (minor 2nds).

C Major Pentatonic Scale

d *r* *m* *s* *l* *d'* *d'* *l* *s* *m* *r* *d*
C D E G A C C A G E D C

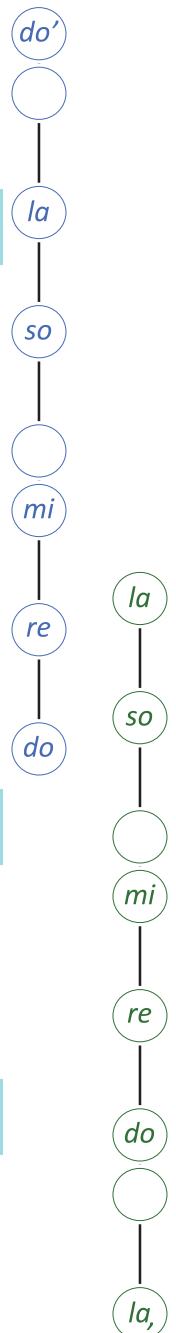
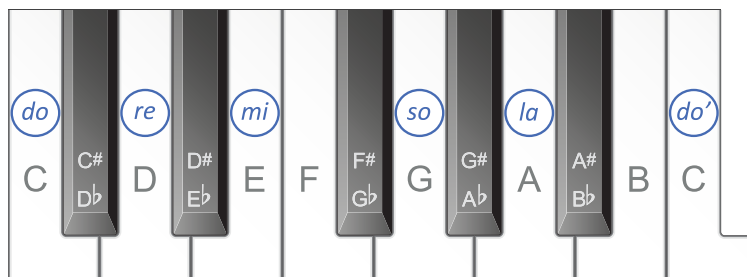

The Minor or *la* Pentatonic Scale

The **minor pentatonic scale** is a five note scale in which *la* is the tonic.

It uses the same notes as the Major pentatonic scale but begins and ends on *la*. (It is the natural minor scale, without *fa* or *ti*).

A Minor Pentatonic Scale

l *d* *r* *m* *s* *l* *l* *s* *m* *r* *d* *l*
A C D E G A A G E D C A

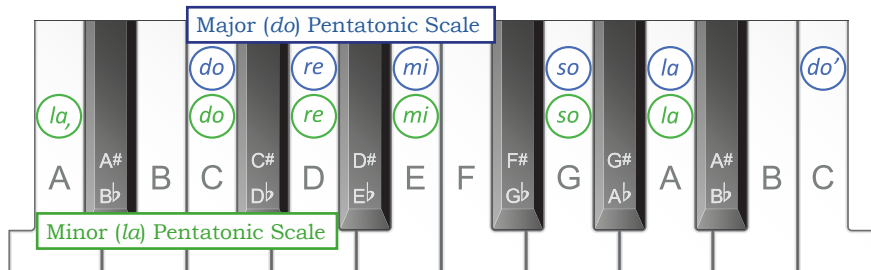

As with all other scales, pentatonic scales can begin on any starting note by keeping the original interval pattern the same. The following two scales are examples of this.

D Major Pentatonic Scale

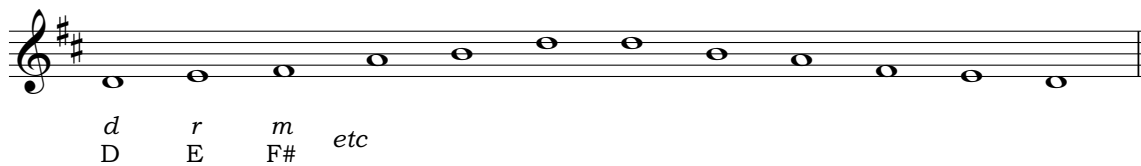

B Minor Pentatonic Scale

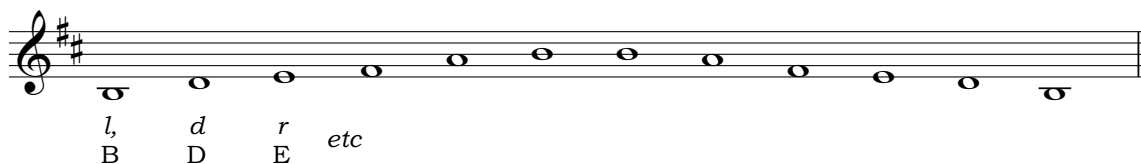

W

Worksheet 50

S9 Scales 1 Write one octave, ascending and descending, in quarter notes, of the Major pentatonic scale beginning on F, using accidentals. Write the solfa beneath each note.

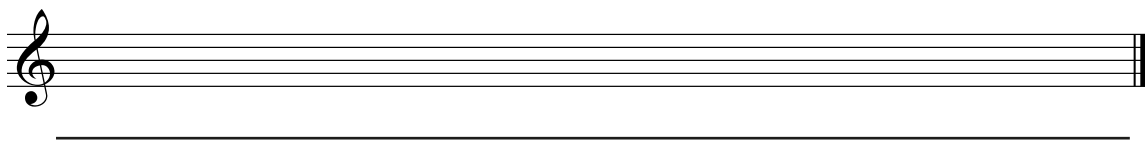

S9 Scales 2 Write the minor pentatonic scale, ascending and descending, related to the scale you have just written. Use a key signature and write the letter names beneath each note.

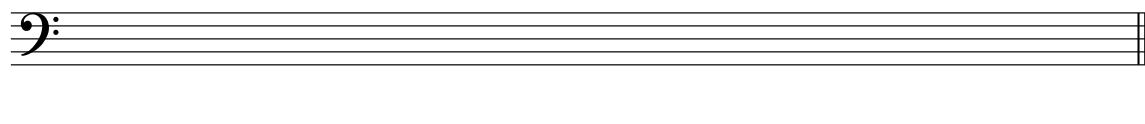

S9 Scales 3 Beginning from the tonic note indicated, write the ascending Major pentatonic scale using a key signature. Identify the interval between each consecutive pair of notes.

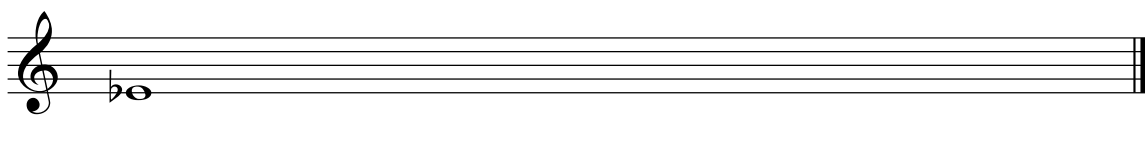

Section 9 - Intervals

Intervals within the Pentatonic Scales

There are no semitones between any consecutive pair of notes in a pentatonic scale (as there is no *fa* or *ti*). The only intervals found in pentatonic scales are Major 2nds and minor 3rds.

Intervals within the Major Pentatonic Scale

Major 2nd Major 2nd minor 3rd Major 2nd minor 3rd



C Major Pentatonic Interval Pattern

do re Ma jor se cond, re mi Ma jor se cond, mi so mi northird, so la
 8 Ma jor se cond, la do mi northird, do la mi northird, la so
 14 Ma jor se cond, so mi mi northird, mi re Ma jor se cond, re do Ma jor se cond.

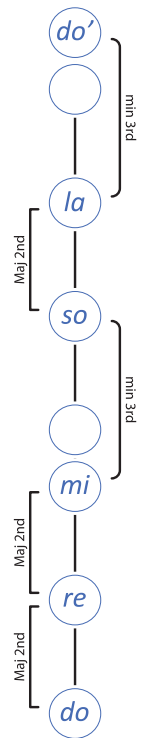

Intervals within the Minor Pentatonic Scale

minor 3rd Major 2nd Major 2nd minor 3rd Major 2nd

C Minor Pentatonic Interval Pattern

la, do mi northird, do re Ma jor se cond, re mi Ma jor se cond, mi so
 8 mi northird, so la Ma jor se cond, la so Ma jor se cond, so mi mi northird,
 15 mi re Ma jor se cond, re do Ma jor se cond, do la, mi northird.

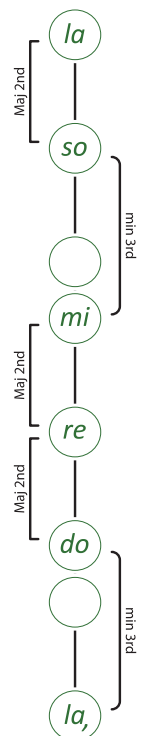



Worksheet 51

S9 Intervals 1 Name these intervals.

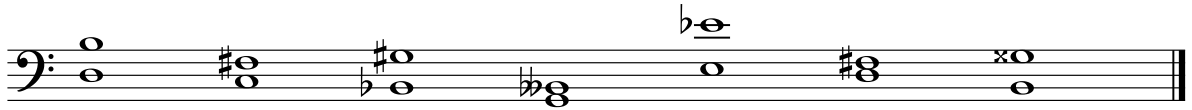

S9 Intervals 2 Write the following intervals.



Major 2nd
above

Aug 8ve
above

dim 6th
below

minor 2nd
below

minor 6th
below

S9 Intervals 3 Name the scale and label intervals between each pair of notes in the scales below.

Scale: _____



Scale: _____

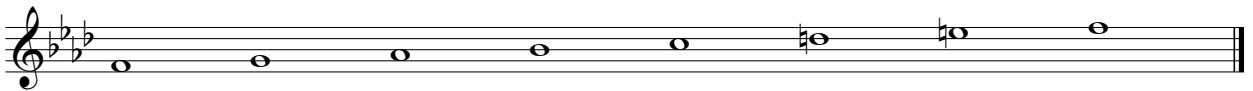

S9 Intervals 4 Identify the bracketed intervals in the following melodies. Write your answers (quality and number) beneath the brackets. Identify the scale this melody is based on and write your answer in the space provided.

Scale: _____

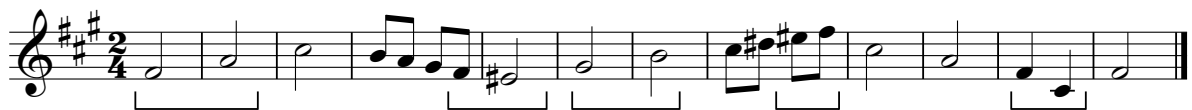

Scale: _____



S9 Intervals 5 Six intervals will be played twice. Name the intervals you hear.

1. _____ 2. _____ 3. _____ 4. _____ 5. _____ 6. _____

Section 9 - Melody

I Follow the steps in this flow chart to determine the tonality of the next two melodies.

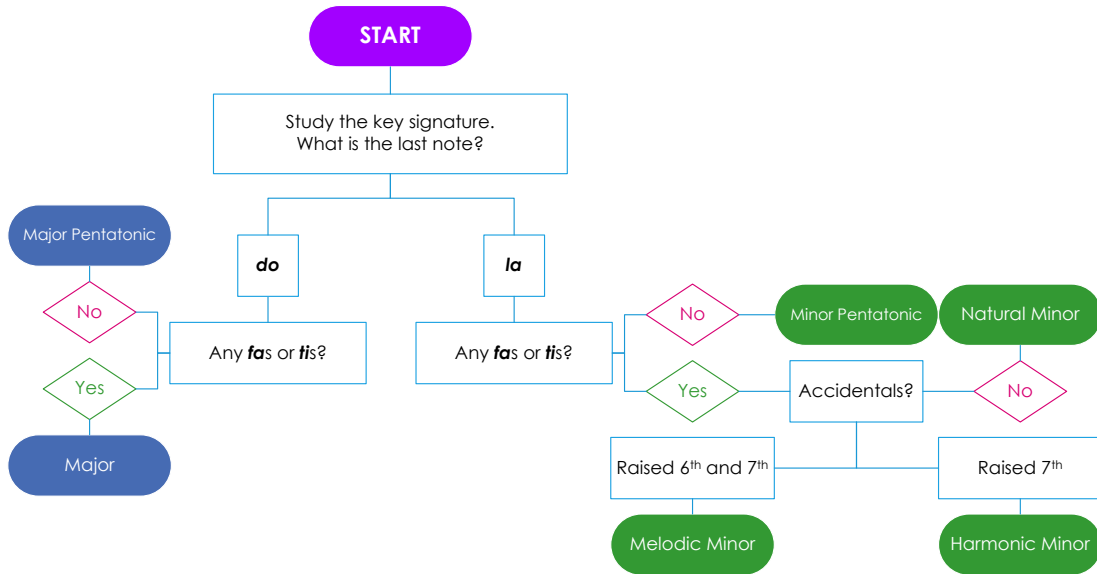

S "Morning" from Peer Gynt Suite No 1

- Study the key signature of this melody. What is the last note?** The four sharps: F#, C#, G# and D# in the key signature indicate that E is *do*. This means the last note: E is *do*.
- Are there any *fas* or *tis*?** **No** When E is *do*, *fa* is A and *ti* is D#. Neither of these notes occurs in "Morning" therefore, this melody is in **E Major Pentatonic**.

Sing this scale and then "Morning" in solfa with handsigns and in letter names.

S Pentonicity

- Study the key signature of this melody. What is the last note?** The three flats: Bb, Eb and Ab, in the key signature indicate that Eb is *do*. This means the last note: C is *la*.
- Are there any *fas* or *tis*?** **No** When C is *la*, *ti* is D and *fa* is Ab. Neither of these notes occurs in "Pentonicity" therefore, this melody is in **C minor pentatonic**.

Sing this scale and then sing "Pentonicity" in solfa with handsigns and in letter names.

S9 Melodic Recognition

2/36

S9 Melodic Transcription 1

2/37

S9 Melodic Transcription 2

2/38

Worksheet 52 cont.

S9 Melodic Transcription 3

6/8

Flute

Clarinet in B \flat

2/39

S9 Melodic Transcription 4

4/4

2/40

S9 Melodic Transcription 5

4/4

Clarinet

Bassoon

2/41

S9 Melodic Transcription 6

4/4

2/42

Section 9 - Chords



Triads in Root Position



All the triads we have studied so far in this book have been in root position.

A **root position triad** has the root note as the **lowest** note of the triad.

Root position triads have notes a 3rd above the root note and a 5th above the root note.

Another way of labelling root position triads is to use figures such as the $\frac{5}{3}$ figures taught in earlier sections of this book. These figures represent the intervals found in the triad above the root note.

This triad has a 3rd and a 5th above C.

Therefore the figures for a root position triad are $\frac{5}{3}$.

Triads in 1st Inversion

If the root note of a $\frac{5}{3}$ chord, such as the C major triad, is moved to the top of the triad, the result is a **first inversion chord**.

A **1st inversion triad** has the root note at the **top** of the triad. 1st inversion triads have notes a 3rd and a 6th above the bottom note.

The quality of the triad does not alter this process. For example, if the C **minor** triad, has the root note moved to the top of the triad, the result is a **minor** triad in **1st inversion**.

In this 1st inversion triad, E \flat , is at the bottom of the triad, the middle note, G, is a 3rd above the bottom note and the top note (the root note), C, is a 6th above the bottom note.

The figures for a 1st inversion triad are $\frac{6}{3}$.



Worksheet 53



S9 Chords 1 In each bar below write the root position triad above the given note. Label this as $\frac{5}{3}$. Next to it, write the 1st inversion triad of the chord you have just written and label this $\frac{6}{3}$. Also write the quality of each pair of chords. The first has been done for you.

S9 Chords 2 Eight triads in root position or 1st inversion will each be played once harmonically and once melodically (with the top note repeated). Write the inversion of the triad you hear.

- 1.
- 2.
- 3.
- 4.
- 5.
- 6.
- 7.
- 8.

Section 9 - Chord Progressions



Imperfect Cadence (Half Close)

An **imperfect cadence** is an unfinished cadence which, when used at the end of a phrase, will sound like a pause or comma rather than a full stop.

An imperfect cadence is made up of two chords, the last of which is **always** chord V . The most common chords to precede chord V are I/i , $\text{ii}/\text{ii}^\circ$, IV/iv and vi/VI .

The examples below are two imperfect cadences in the key of C Major.



IV V

ii V

Interrupted Cadence (Deceptive or Surprise Cadence)

An **interrupted cadence** is another cadence used at the end of an internal phrase, so called because after the first chord, V , we expect to hear a chord I/i to form a perfect cadence but it is interrupted by a chord vi/VI instead. This last chord of the cadence creates a "surprise" or unexpected ending to the phrase.

An interrupted cadence, therefore, is made up of chord V followed by chord vi/VI .

The examples below are interrupted cadences - the first in the key of D Major and the second in the key of B minor.



V vi

V VI



Worksheet 54

S9 Cadences Five cadences will be played. They will be either Perfect, Plagal, Imperfect or Interrupted. Identify each cadence in the spaces provided.

2/44

1. 2. 3. 4. 5.

S9 Chord Progressions Theory 1 Write the following root position triads in F Major using a key signature.

IV ii iii V vii^o vi I

Worksheet 54 cont.

S9 Chord Progressions Theory 2 Write the following root position triads in E harmonic minor using accidentals.

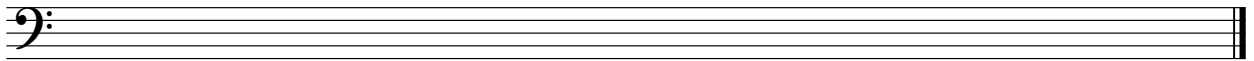

i V ii^o VI III⁺ vii^o iv

Chord Progression Transcription Instructions Two chord progressions, using any root position triad found in a Major or harmonic minor scale, will be played several times. The first (tonic) chord is printed at the start of each progression. Complete the transcription chord chart before the first playing. Identify the chords you hear using the harmonic grid and identify the cadence created by the last two chords in the space provided.

S9 Chord Progression 1 - Transcription Chord Chart

E ^b	F	G	A ^b			
				s	l	t
				V	vi	vii ^o

S9 Chord Progression 1 Cadence: _____

2/45

Harmonic Grid 1. d' 2. 3. 4. 5.

Bass note	E ^b				
Quality	Major				

S9 Chord Progression 2 - Transcription Chord Chart

A				E		
l,	t,	d	r	m	f	si
i				V		

S9 Chord Progression 2 Cadence: _____

2/46

Harmonic Grid 1. l 2. 3. 4. 5.

Bass note	A				
Quality	minor				

Section 9 - Revision & Practice Questions

Theory Revision

W

S9 Rhythm Write the beat counts (and pulses in compound time) beneath each bar in the rhythms below. The first bar of each example has been done for you.

1 2 3 4

1 & a 2 & a

W

S9 Melodic Composition Create a melody in C minor pentatonic by writing the rhythm on the rhythm staff, the solfa underneath this rhythm and then transferring this onto the treble staff below. Sing in solfa and in letter names once you have finished.

P

Musicianship Practice

PRACTICE ACTIVITIES

- Read simple time rhythms in rhythm names while conducting, inner hearing all new dotted rhythms
- Compose rhythms (using new rhythms) then read in rhythm names while conducting
- Sing the Major and minor pentatonic scales in solfa with handsigns
- Sing the Major and minor pentatonic minor scales in letter names in various keys up to 3 \sharp and \flat s
- Sing the consecutive intervals within Major and minor pentatonic scales.
- Sing Major and minor pentatonic melodies in solfa with handsigns
- Compose Major and minor pentatonic melodies then sing in solfa with handsigns
- Sing Major, minor, diminished, Augmented and Suspended 4th chords with intervals in solfa with handsigns, from the same bottom note
- Sing chord progressions in full

Section 10 - Rhythm



$\frac{6}{4}$ is the time signature used in **Rhythmic Example 41**. The $\overline{6}$ at the top means there are six pulses per bar and the $\underline{4}$ at the bottom means these pulses are quarter note, or crotchet, pulses.



$\frac{6}{4}$ can be described as **compound duple time** (similar to $\frac{6}{8}$ but with dotted minim beats).

It has six crotchet pulses:



and

two dotted minim beats:

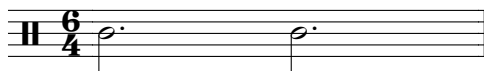

per bar.

This time signature is usually conducted with two beats per bar but is sometimes conducted in six depending on the tempo of the excerpt.



Rhythmic Example 42

Crotchet pulses:



$\frac{9}{4}$ is the time signature used in **Rhythmic Example 43**. The $\overline{9}$ at the top means there are nine pulses per bar and the $\underline{4}$ at the bottom means these pulses are quarter note or crotchet pulses.



$\frac{9}{4}$ can be described as **compound triple time** (similar to $\frac{9}{8}$ but with dotted minim beats).

It has nine crotchet pulses per bar:



and

three dotted minim beats per bar:

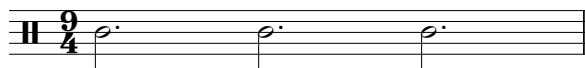

This time signature is usually conducted with three beats per bar but is sometimes conducted in nine depending on the tempo of the excerpt. This time signature is not commonly used.



Rhythmic Example 43

Crotchet pulses:

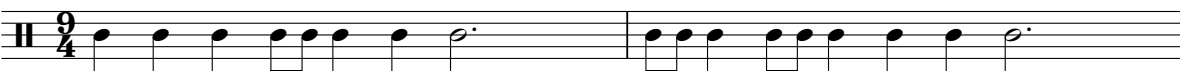



Asymmetrical Time Signatures



$\frac{5}{4}$ is an irregular or asymmetrical time signature consisting of five crotchet beats per bar. This time signature can be described as **Simple Quintuple**.

In irregular time signatures, beats can be grouped in various ways to create accents within the bar. Rhythmic Example 44 shows the beats grouped as 2 + 3 i.e. the **natural** accents fall on the first and third beats of each bar.



Rhythmic Example 44

Crotchet pulses:

The beats in $\frac{5}{4}$ can also be grouped as 3 + 2 as in Rhythmic Example 45.



Rhythmic Example 45

Crotchet pulses:

$\frac{5}{8}$ is another asymmetrical time signature consisting of five quaver beats per bar.

The beats in $\frac{5}{8}$ can also be grouped in several different ways. Rhythmic Example 45 shows the quavers grouped as 3 + 2.



Rhythmic Example 46

Quaver pulses:



Some other asymmetrical time signatures are $\frac{7}{4}$ with seven crotchet beats per bar and $\frac{7}{8}$ with seven quaver beats per bar.



In time signatures with seven beats per bar, these beats can be grouped as 2 + 2 + 3 (as in Rhythmic Example 47) 3 + 2 + 2 (as in Rhythmic Example 48) or 2 + 3 + 2.



Rhythmic Example 47

Crotchet pulses: | | | | | | | | | | | |

2 + 2 + 3



Rhythmic Example 48

Quaver pulses: | | | | | | | | | | | | | | | | | | | | | |

3 + 2 + 2



Worksheet 55

S10 Rhythmic Transcription 1

2/47

S10 Rhythmic Transcription 2

2/48

S10 Rhythmic Transcription 3

2/49

S10 Rhythmic Transcription 4

2/50

S10 Rhythmic Transcription 5

2/51

Worksheet 55 cont.

S10 Rhythmic Transcription 6

2/52

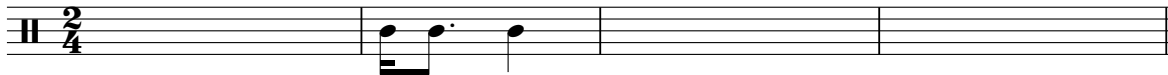
S10 Rhythmic Transcription 7

2/53

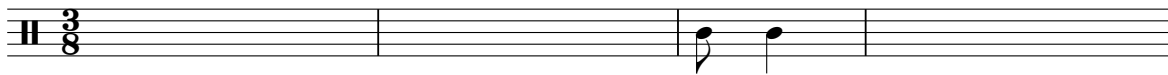
S10 Rhythmic Transcription 8

2/54

S10 Rhythmic Recognition

2/55

S10 Rhythm Theory Complete each bar using two notes and one rest.

Section 10 - Scales



The Blues Scale



The **blues** is a style of music that is believed to have originated in the African-American communities of the southern States of America in the late 1800s. The word: **blues** refers to the feelings of melancholy, sadness, adversity and depression that are reflected in the music of this time.

The **hexatonic blues scale** is a six note scale closely related to the minor pentatonic scale. It can be seen as the minor pentatonic scale plus the flattened 5th note *mi* becomes *maw*:



A Blues Scale

l *d* *r* *maw* *m* *s* *l* *s* *m* *maw* *r* *d* *l*
 A C D Eb E G A G E Eb D C A

Worksheet 56

S10 Scales 1 On the given staff, write one octave, ascending and descending, in semibreves, of the blues scale beginning on B using only accidentals. Mark the semitones with slurs.

S10 Scales 2 Beginning on the tonic note indicated, write the descending blues scale. Use a key signature and accidentals as required and write the solfa beneath each note.

S10 Scales 3 Beginning on the tonic note indicated, write the ascending and descending blues scale. Use a key signature and accidentals as required and write the solfa beneath each note.

S10 Scales 4 Three scales will be played twice. They will be one of the following: Major Major Pentatonic harmonic minor blues or melodic minor. Identify each scale in the spaces provided.

1.

2.

3.

Section 10 - Intervals

Intervals within the Blues Scale

minor 3rd Major 2nd minor 2nd Aug Unison minor 3rd Major 2nd

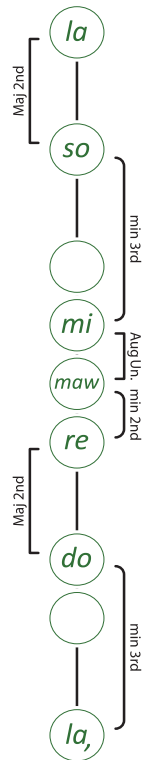

C Blues Interval Pattern

la, do mi-nor third, do re Ma-jor se-cond, re maw mi-nor se-cond,
 7 maw mi Aug-men-ted un-i-son, mi so mi-nor third, so la Ma-jor se-cond, etc



Worksheet 57

S10 Intervals 1 Write these intervals above the given notes.

Aug 8ve minor 3rd Major 7th Perf 4th minor 7th dim 6th Aug 2nd

S10 Intervals 2 Identify the bracketed intervals in the following melody. Write your answers (quality and number) beneath the brackets.

S10 Intervals 3 A melody will be played several times. The rhythm of this melody is printed below. Identify the first and last intervals (quality and number) and write your answers beneath the brackets and circle the tonality of the melody below.

2/57

Scale form: minor pentatonic Major Harmonic minor Melodic minor

S10 Intervals 4 Six intervals will be played twice. Name the intervals you hear.

2/58

1. _____
2. _____
3. _____
4. _____
5. _____
6. _____

Section 10 - Melody

I Follow the steps in this flow chart to determine the tonality of "Dark Blue".

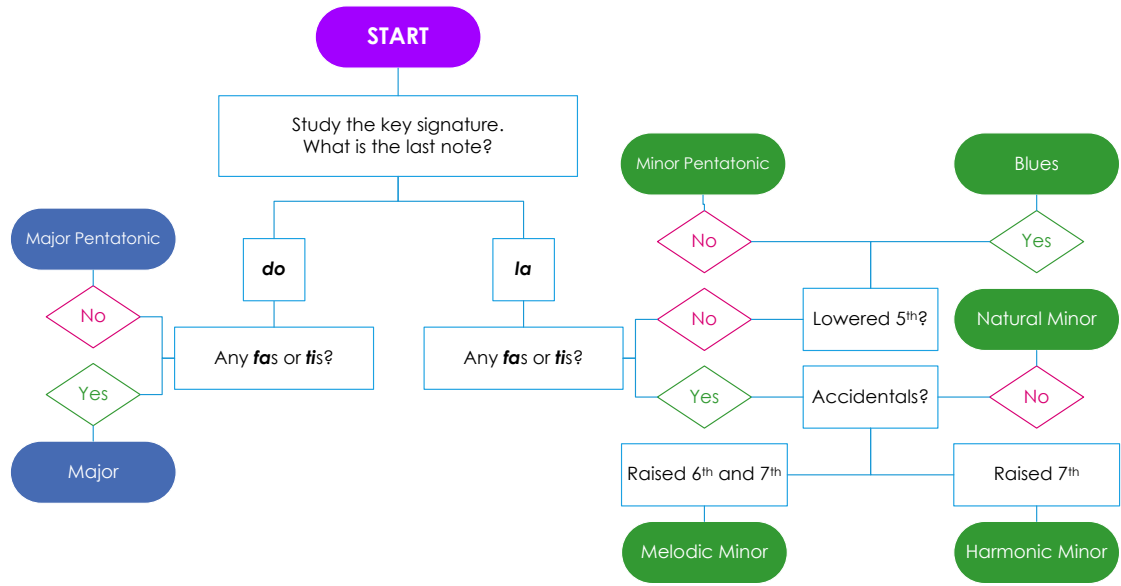

Dark Blue



- 1. Study the key signature of this melody. What is the last note?** The three flats: B \flat , E \flat and A \flat , in the key signature indicate that E \flat is *do*. This means the last note: C is *la*.
- 2. Are there any fas or tis?** **No** When C is *la*, *ti* is D and *fa* is A \flat . Neither of these notes occurs in "Dark Blue".
- 3. Is there a lowered 5th?** **Yes** The 5th note above C is G (*mi*) and there is a G \flat (*maw*) in bars two and six therefore, "Dark Blue" is based on the **C blues scale**.

Sing the C blues scale and then "Dark Blue" in solfa with handsigns and in letter names.

Worksheet 58

S10 Melodic Transcription 1

Worksheet 58 cont.

S10 Melodic Transcription 2

2/60

S10 Melodic Transcription 3

2/61

S10 Melody Answer the questions about the melody below.

1. Is this melody based on *do* or *la*? _____
2. Which tonalities could this melody be based on?

3. Are there any *fas* or *tis* in this melody? _____
4. Which tonalities could the melody be based on now? _____
5. Are there any two notes with the same letter name but two different versions e.g. G# and Gb?

6. What tonality is this melody in? _____

Section 10 - Chords



Triads in 2nd Inversion



In this 2nd inversion triad the G is at the bottom of the triad, the middle note (the root note) C is a 4th above the bottom note and the top note, E is a 6th above the bottom note.

A **2nd inversion triad** has the root note in the **middle** of the triad. 2nd inversion triads have notes a 4th above the lowest note and a 6th above the lowest note

Therefore the figures for a 2nd inversion triad are $\overset{6}{4}$.

Root Position	1st Inversion	2nd Inversion

An interval that can help determine the inversion of a triad is the **4th**.

- A root position triad has a 3rd between the bottom two notes and the top two notes therefore there is **no interval of a 4th** in a root position triad.
- A 1st inversion triad has a 3rd between the bottom two notes and a **4th at the top** of the triad.
- A 2nd inversion triad has the **4th at the bottom** of the triad and a 3rd at the top.

Worksheet 59

S10 Chords 1 In each bar write a root position, Major triad above the given note then the 1st inversion and 2nd inversion triads of the chord you have just written. Write the figures below each chord. The first example has been done.

S10 Chords 2 Eight triads in root position, 1st inversion or 2nd inversion will each be played, once harmonically and once melodically (with the top note repeated). Write the inversion of the triad you hear (root, 1st or 2nd).

2/62

- 1.
- 2.
- 3.
- 4.
- 5.
- 6.
- 7.
- 8.

S10 Chords 3 In the tonic keys indicated, using accidentals, write and name the specified chords.

- | | | | |
|---------------------|--------------------------------|----------------------------------|-----------------------|
| dominant
F Major | supertonic
C harmonic minor | leading note
B harmonic minor | submediant
D Major |
|---------------------|--------------------------------|----------------------------------|-----------------------|



Worksheet 59 cont.

S10 Chords 4 Write the following triads on the given staff using accidentals where necessary.

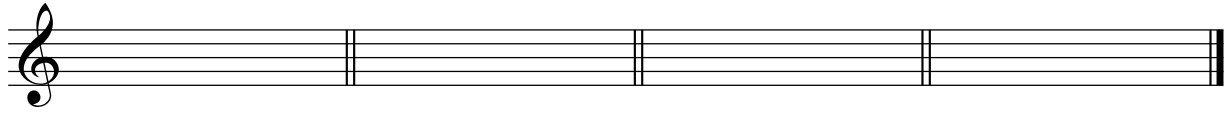
B \flat Major

D Augmented

C diminished

B \flat minor

S10 Chords 5 Write, and label using Roman numerals, the primary triads in D Major in the treble clef, and in C minor in the bass clef. Use key signatures.



S10 Chords 6 Write the Roman numerals of the following triads found in the Major key with the given key signature.

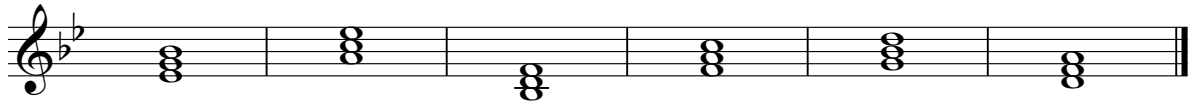

S10 Chords 7 Write the triads, indicated by the Roman numerals, found in the harmonic minor key with the given key signature.

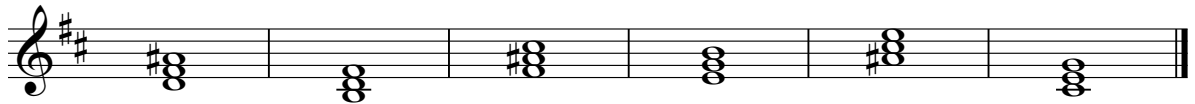

S10 Chords 8 Write the following triads on the given staff.

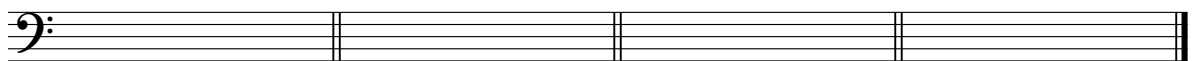

E minor

A Augmented

C diminished

D Major

S10 Chords 9 Five triads will be played three times: harmonically, as an arpeggio and harmonically again. They will be either Major, minor, diminished, Augmented or suspended 4th triads. Write the quality of each triad in the spaces provided.

2/63

1. _____ 2. _____ 3. _____ 4. _____ 5. _____

S10 Chords 10 Five triads will be played twice. They will be either Major, minor, diminished, Augmented or suspended 4th triads. Write the quality of each triad in the spaces provided.

2/64

1. _____ 2. _____ 3. _____ 4. _____ 5. _____

Section 10 - Chord Progressions



Worksheet 60

S10 Cadences Five cadences will be played. They will be either Perfect, Plagal, Imperfect or Interrupted. Identify each cadence in the spaces provided.

2/65

1. _____ 2. _____ 3. _____ 4. _____ 5. _____

Write the transcription chord chart out first for all chord progression transcriptions.

Chord Progression Transcription Instructions Four chord progressions, using any root position triad found in a Major or harmonic minor scale, will be played several times. The first (tonic) chord is printed at the start of each progression. Identify the chords you hear using the harmonic grid and identify the cadence created by the last two chords in the space provided.

S10 Chord Progression 1 Cadence: _____

2/66

<i>Harmonic Grid</i>	1. <i>d</i>	2.	3.	4.
Bass note	C			
Quality	Major			

S10 Chord Progression 2 Cadence: _____

2/67

<i>Harmonic Grid</i>	1. <i>d</i>	2.	3.	4.	5.
Bass note	C				
Quality	Major				

S10 Chord Progression 3 Cadence: _____

2/68

<i>Harmonic Grid</i>	1. <i>l</i>	2.	3.	4.	5.
Bass note	A				
Quality	minor				

S8 Chord Progression 4 Cadence: _____

2/69

<i>Harmonic Grid</i>	1. <i>l</i>	2.	3.	4.	5.
Bass note	B				
Quality	minor				

Section 10 - Revision & Practice Questions

Theory Revision

W

S10 Rhythm Identify the time signature for each of these bars.



W

S10 Scales Answer the questions about the melody below.

1. Is this melody based on *do* or *la*? _____
2. Which tonalities could this melody be based on?

3. Are there any *fas* or *tis* in this melody? _____
4. Which tonalities could the melody be based on now? _____
5. Are there any two notes with the same letter name but two different versions e.g. G# and Gb?

6. What tonality is this melody in? _____



P

Musicianship Practice

PRACTICE ACTIVITIES

- Read rhythms in rhythm names, inner hearing a specific rhythmic element, while conducting
- Compose rhythms (in new time signatures) then read in rhythm names while conducting
- Sing the blues scale in solfa with handsigns
- Sing the Major, natural, harmonic, melodic minor, Major and minor Pentatonic and the blues scales in solfa with handsigns
- Sing the blues scale in letter names in various keys up to 3# and b
- Sing the consecutive intervals within the blues scale.
- Sing blues melodies in solfa with handsigns
- Compose blues melodies then sing in solfa with handsigns
- Sing Major, minor, diminished, Augmented and Suspended 4th chords with intervals in solfa with handsigns, from the same top note
- Sing chord progressions in full

Section 11 - Rhythm



The Triplet

A triplet is defined as three notes played in the time of two.



Quaver Triplet in Simple Time

In simple time there are usually two quavers on a beat:



A quaver triplet (tri-ple-ti) occurs when three quavers are played on one beat - three played in the time two would normally be played:

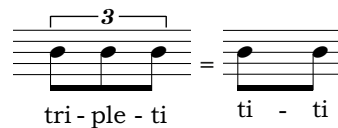

Rhythmic Example 49



New Rhythmic Shorthand

In simple time, when three sounds are heard on a beat the following options are possible:

The shorthand for the quaver triplet can be: §



Crotchet Triplet in Simple Time

A crotchet triplet (tri-ple-ta) occurs when three crotchets are played on two beats - three played in the time two would normally be played:

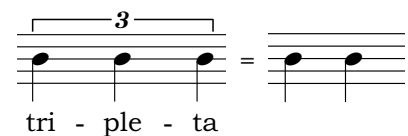

Rhythmic Example 50



Three Part Rhythm



Changing or Mixed Metres

Another form of irregular metre is created when a composer changes time signature at the beginning of each bar. When this happens the time signature does not give a predictable "feel" of strong and weak beats but rather creates an unpredictable pattern of accents.

Read the rhythm of these next two examples using the rhythm names while tapping or conducting the beat. Note the symbols: ♩ or ♪ above the first bar. This indicates that the beat or pulse itself (crotchet or quaver) remains constant throughout the work even though the time signature changes.



Rhythmic Example 51



Rhythmic Example 52



Worksheet 61

S11 Rhythmic Transcription 1

Worksheet 61 cont.

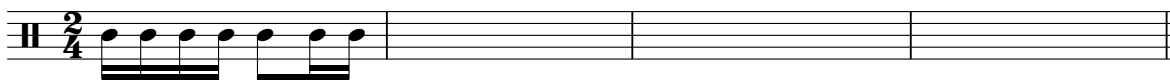
S11 Rhythmic Transcription 2

2/71

S11 Rhythmic Transcription 3 Note the use of crotchet pulse strokes instead of beat strokes for this time signature.

2/72

S11 Rhythmic Transcription 4

2/73

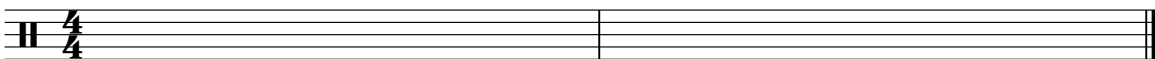
S11 Rhythmic Transcription 5

2/74

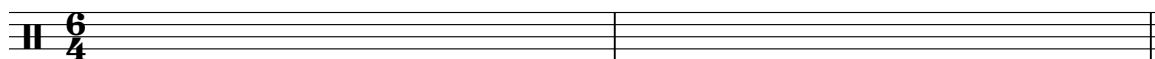
S11 Rhythmic Transcription 6

2/75

Worksheet 61 cont.

S11 Rhythmic Transcription 7

2/76

S11 Rhythmic Transcription 8

2/77

S11 Rhythmic Transcription 9

2/78

S11 Rhythmic Recognition

2/79

A B

C D

E F

S11 Rhythm Theory Complete each bar using two notes and one rest.

Section 11 - Scales



Modes

Modes are scale forms used as a basis for music composed prior to the 17th century when the current Major and minor system took over as the scale system in common usage.

The interval patterns that create the most common modes can be found today by starting on any white note on the piano and playing all the white notes ascending for one octave.

Play middle C and then the white notes ascending and descending for one octave and you will have played the mode known as the **Ionian mode**. This is now the Major scale.

Ionian Mode or C Major Scale

Another example of a common mode begins on A and contains all the white notes ascending and descending for one octave. This mode is known as the **Aeolian mode**, which is now known as the natural minor scale.

Aeolian Mode or A Natural Minor Scale

As with Major and minor scales, modes can be transposed to begin on a new starting note by keeping the original interval pattern the same.

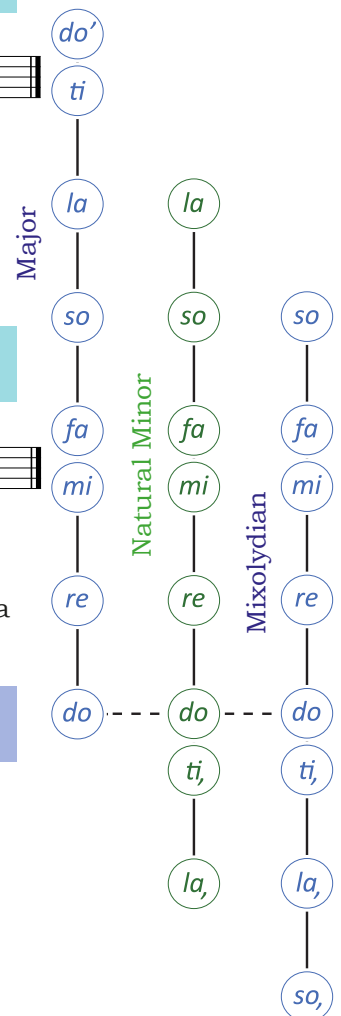

The Mixolydian Mode

The interval pattern of the Mixolydian mode can be found by playing the white notes on a piano starting on G or by singing the notes of a Major scale in solfa starting on so instead of do. Notice that the semitones are still found between *mi* and *fa* and *ti* and *do'* as marked by the slurs in the following scale.

Mixolydian Mode on G

Singing Modes

There are two common ways of singing modes:

- 1. Authentic:** Uses the solfa belonging to the key signature of the scale or melody, see the Mixolydian mode (in the key of C Major) on page 137. This form has no altered notes or
- 2. Altered:** This approach uses the Major or minor scale that it is most closely related to and chromatically alter any notes that are not in this scale.

For example, the G Mixolydian mode is almost identical to G Major except that it has an F \flat instead of an F \sharp . Therefore, you can use *do* for the tonic note, as in G Major, and lower the 7th note i.e. *ti* becomes *taw* (pronounced as in "torn"):



Mixolydian Mode in G Major (with a lowered 7th)

For most students the second choice (Major with a lowered 7th) is the most comfortable to sing due to familiarity with *do* as the tonic note. The authentic version is used more when identifying scales or tonalities. However, it is good practice to use both forms.



Worksheet 62

S11 Scales 1 Read the following statement then write one octave ascending of the Mixolydian mode beginning on D in crotchets. Show the semitones with slurs.

If D = *so* then G = *do* and the key signature of G Major is 1 sharp: F \sharp

S11 Scales 2 Complete the following statement then write one octave ascending of the Mixolydian mode beginning on F in crotchets. Slur the semitones and label the consecutive intervals below the staff.

If F = *so* then ___ = *do* and the key signature of _____ is _____

S11 Scales 3 Complete the following statement then write one octave descending of the Mixolydian Mode beginning on G. Use semibreves and identify the interval between each consecutive pair of notes.

If G = *so* then ___ = *do* and the key signature of _____ is _____

Section 11 - Intervals

Intervals within the Mixolydian Mode

Major 2nd Major 2nd minor 2nd Major 2nd Major 2nd minor 2nd Major 2nd

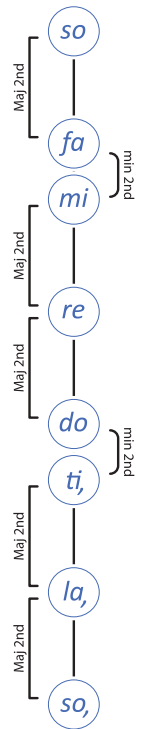

Mixolydian Mode Interval Pattern

so la Ma jor se cond, la ti Ma jor se cond, ti do mi nor se cond. do re

8 Ma jor se cond, re mi Ma jor se cond, mi fa mi nor se cond, fa so Ma jor se cond, etc



Worksheet 63

S11 Intervals 1 A melody will be played several times. The rhythm of this melody is printed below. Identify the first and last intervals (quality and number) and write your answers beneath the brackets and circle the tonality of the melody below.

Scale form: melodic minor Major Pentatonic harmonic minor Major

S11 Intervals 2 A melody will be played several times. The rhythm of this melody is printed below. Identify the first and last intervals (quality and number) and write your answers beneath the brackets and circle the tonality of the melody below.

Scale form: natural minor minor pentatonic harmonic minor Major

S11 Intervals 3 Write the following intervals.

Major 6th below Augmented 7th below Augmented 5th above Major 3rd above Major 2nd below

Section 11 - Melody



Follow the steps in this flow chart to determine the tonality of the "Palestrina Canon".

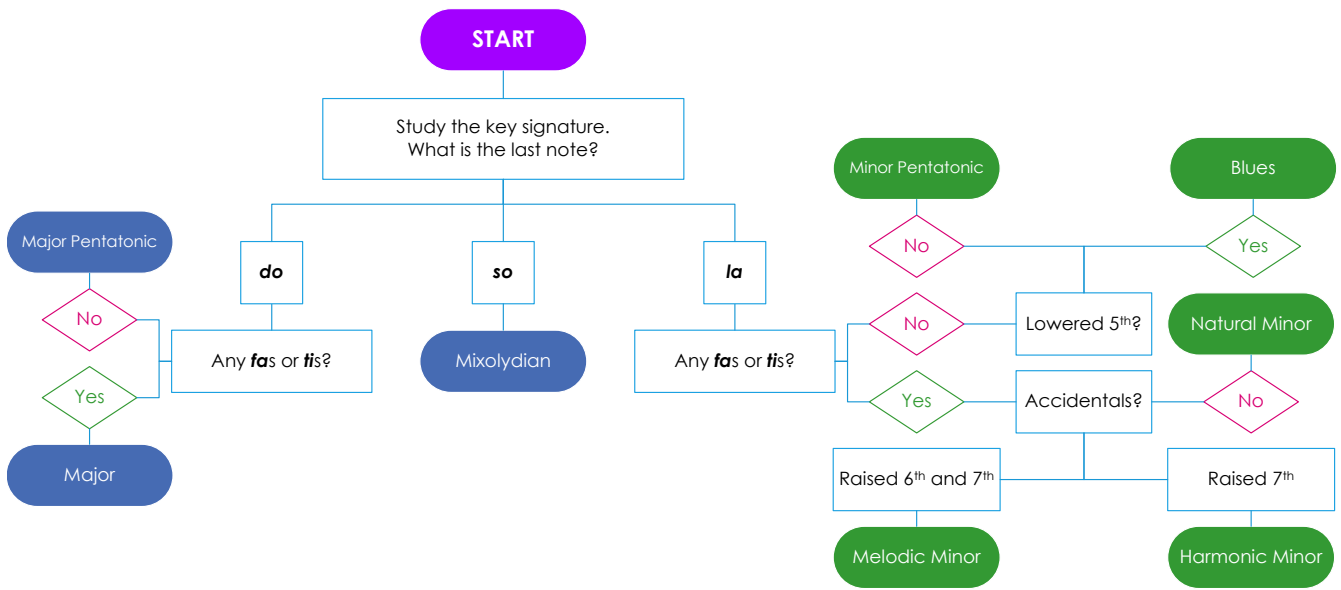

Palestrina Canon

Giovanni Palestrina

1. 2.

Authent c so, la, la, ti, mi re do re do ti, do re mi fa etc
 Altered Major do re re mi la so fa so fa mi fa so la taw etc

Mixolydian Mode - Authentic

Mixolydian Mode - Altered

Study the key signature of this melody. What is the last note?

The one sharp: F# in the key signature indicate that G is *do*.
 This means the last note: D is **so**.

Therefore, the "Palestrina Canon" is based on the **D Mixolydian mode**.

The solfa written under the notes of the "Palestrina Canon" is shown in both **authentic** (*so* as the tonic):

so, la, ti, do re mi fa so fa mi re do ti, la, so,
 D E F# G A B C D C B A G F# E D

and **altered** Major versions (*do* as the tonic with flattened 7th):

do re mi fa so la taw do taw la so fa mi re do
 D E F# G A B Cb D Cb B A G F# E D

Sing the Mixolydian mode then the "Palestrina Canon" using both versions of the solfa, with handsigns.

Worksheet 64

S11 Melodic Transcription 1

6/8

2/82

S11 Melodic Transcription 2

4/4

2/83

Vibraphone

Bass Clarinet

Bass Trombone

S11 Melody Transpose the following D minor pentatonic melody into F minor pentatonic. Write the solfa beneath the two given scales and the melody to be transposed. Use this information to aid transposing.

Section 11 - Chords



7th Chords

7 7th chords are chords made up of four different notes. They can be built on any scale degree. A **3** 7th chord (in root position) will have a root note, a note a third higher, a note a fifth higher and a note a seventh higher than the root note. The $\frac{7}{3}$ is usually shortened to $\frac{7}{}$.

The Dominant 7th Chord

Perhaps the most common of all 7th chords, the Dominant 7th chord (in root position) is made up of a root note and the notes a Major 3rd, a Perfect 5th and a minor 7th above the root note.

The Dominant 7th chord is so named because it is naturally found on the dominant or 5th degree of Major and harmonic minor scales. This chord is labelled V^7 in Roman numerals.

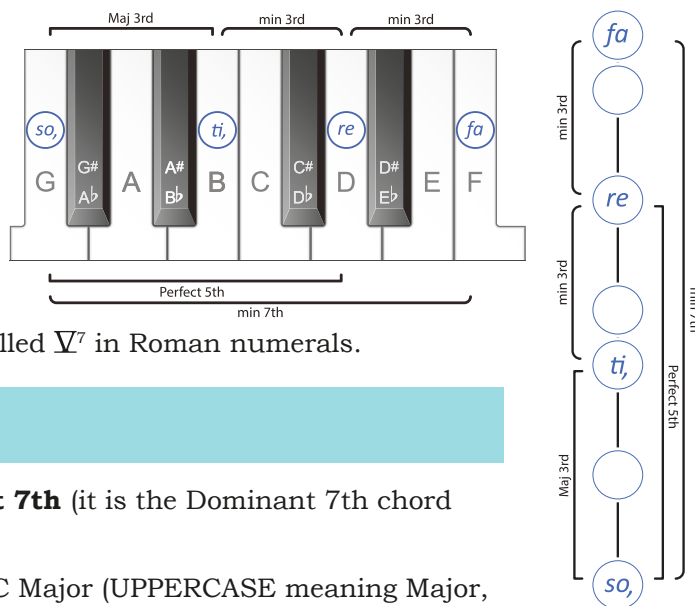

Labelling Dominant 7th Chords

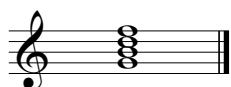

Chord Name: G Dominant 7th (it is the Dominant 7th chord built on G)

Roman numeral with Figures: Chord V^7 in C Major (UPPERCASE meaning Major, the Roman numeral 5, showing the scale degree the chord is built on, with the small seven representing all the figures: $\frac{7}{3}$ indicating that the chord has a 7th, 5th and 3rd above the root note).

Tonal or Functional Name: This triad can be called the **G Dominant 7th chord** (all the notes in this triad belong to the C Major scale and it is built on the dominant of C Major) or the **Dominant 7th of C Major**.

Dominant 7th Chords - in Major and Minor Keys

Dominant 7th Chords can **only** be built on the 5th scale degree of a Major scale:

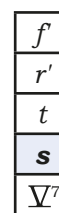
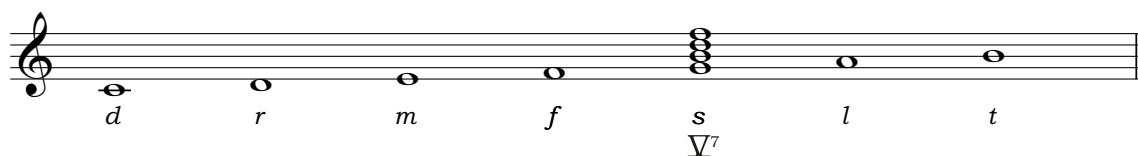

and on the 5th scale degrees of a harmonic minor scale:

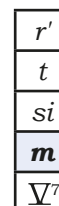
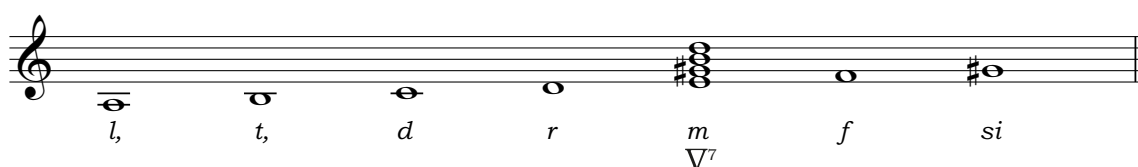

Intervals within a Dominant 7th Chord

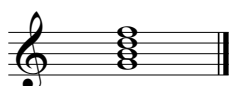

In this V^7 chord, G is the root note, G to B is a Major 3rd, B to D and D up to F are both minor 3rds. G up to D is a Perfect 5th and G up to F is a minor 7th.

G Dominant 7th Chord Melodically

s t r' f r' t s Dominant 7th

The structure of the 3rds found in a Dominant 7th chord is **Major, minor, minor**



Intervals in the (G) Dominant 7th Chord

s t r' f f r' t s Dominant 7th s t Major 3rd, 7th

t r' minor 3rd, r' f minor 3rd, s r' Perfect 5th, s f minor 7th.



Worksheet 65

S11 Chords 1 Write a Dominant 7th chord (chord V7) on each of the given notes using accidentals where necessary.

S11 Chords 2 In the tonic keys indicated, write and name the specified chords.

Dominant 7th	mediant	Dominant 7th	subdominant
B \flat Major	E harmonic minor	C harmonic minor	E \flat Major

S11 Chords 3 What is the solfa of a Dominant 7th chord in a minor key? _____

Where is the raised 7th found in a Dominant 7th chord? _____

Write the Dominant 7th chord found in the minor keys with the following key signatures. The first has been done for you.

S11 Chords 4 Write a tonic chord in 2nd inversion in the following Major keys.

S11 Chords 5 Five chords will be played three times each.

They will be Major, minor, diminished, Augmented or suspended 4th triads or the Dominant 7th chord. Write the quality of each chord in the spaces provided.

- 1.
- 2.
- 3.
- 4.
- 5.

Section 11 - Chord Progressions

W Chord Charts for Transcriptions - including the Dominant 7th Chord

Knowing the possibilities that can occur on each bass note will help correctly label chords in a chord progression. This is why writing out shorthand versions of the chord charts helps narrow the possible chord options in harmonic transcriptions. Here are all triads and the Dominant 7th chord in a Major key (C Major) on the staff and in transcription chord chart form:

d I *r* ii *m* iii *f* IV *s* V *s* V⁷ *l* vi *t* vii^o

Major Scale Chord Progression Transcription Chart Example (C Major)

C	D	E	F	G	A	B
<i>d</i>	<i>r</i>	<i>m</i>	<i>f</i>	<i>s</i>	<i>l</i>	<i>t</i>
I	ii	iii	IV	V	vi	vii ^o
				V ⁷		

and in a harmonic minor key (A minor):

l i *t* ii^o *d* III⁺ *r* iv *m* V *m* V⁷ *f* VI *si* vii^o

Minor Scale Chord Progression Transcription Chart Example (A minor)

D	E	F	G	A	B \flat	C \sharp
<i>l</i>	<i>t</i>	<i>d</i>	<i>r</i>	<i>m</i>	<i>f</i>	<i>si</i>
i	ii ^o	III ⁺	iv	V	VI	vii ^o
				V ⁷		



Major Chord Chart - Practice Version (Triads and the Dominant 7th)

Sing this chord chart vertically (i.e. all the triads and 7th chords in the Major scale, melodically).

					<i>f</i>		
<i>s</i>	<i>l</i>	<i>t</i>	<i>d'</i>	<i>r'</i>	<i>r'</i>	<i>m'</i>	<i>f'</i>
<i>m</i>	<i>f</i>	<i>s</i>	<i>l</i>	<i>t</i>	<i>t</i>	<i>d'</i>	<i>r'</i>
<i>d</i>	<i>r</i>	<i>m</i>	<i>f</i>	<i>s</i>	<i>s</i>	<i>l</i>	<i>t</i>
I	ii	iii	IV	V	V ⁷	vi	vii ^o

Transcription of a Chord Progressions including 7th Chords

Once 7th chords are added to the possible chords you will hear in a chord progression the process for answering these transcriptions changes slightly. 7th chords are **discords** (meaning they clash or sound discordant) and therefore are often easiest to recognise the first time you hear a chord progression. During the first playing, listen for 7th chords and, if you hear one, place a 7 in the top right hand corner of the quality box in the harmonic grid. Continue as normal for the rest of the playings but avoid the temptation to change/remove the 7th you heard at the start as 7th chords can sound less discordant the more often you hear them.

Notice that the quality of a triad built on the 5th scale degree is Major, however, the quality of a 7th chord built on the 5th scale degree is a Dominant 7th.

Worksheet 66

Write the transcription chord chart out first for all chord progression transcriptions.

Chord Progression Transcription Instructions Four chord progressions, using any root position triad or Dominant 7th chord found in a Major or harmonic minor scale, will be played several times. The first (tonic) chord is printed at the start of each progression. Identify the chords you hear using the harmonic grid and identify the cadence in the space provided.

S11 Chord Progression 1 Cadence: _____

2/85

Harmonic Grid	1. <i>l</i>	2.	3.	4.
Bass note	G			
Quality	minor			

S11 Chord Progression 2 Cadence: _____

2/86

Harmonic Grid	1. <i>d</i>	2.	3.	4.	5.
Bass note	C				
Quality	Major				

S11 Chord Progression 3 Cadence: _____

2/87

Harmonic Grid	1. <i>l</i>	2.	3.	4.	5.
Bass note	A				
Quality	minor				

S11 Chord Progression 4 Cadence: _____

2/88

Harmonic Grid	1. <i>d</i>	2.	3.	4.	5.
Bass note	G				
Quality	Major				

Section 11 - Revision & Practice Questions

Theory Revision

W

S11 Rhythm Rewrite the following rhythm, correctly grouping the notes to show the beats, on the given staff.

W

S11 Scales Complete the following statement then write one octave ascending of the Mixolydian mode beginning on the given note, using the given note's rhythmic value. Slur the semitones, write the solfa using the authentic (so based) form and use the key signature belonging to *do*.

If E = *so* then ___ = *do* and the key signature of _____ is 3 sharps: _____

S11 Chords Write a Dominant 7th chord (chord V7) **below** each of the given notes using accidentals where necessary.

P

Musicianship Practice

PRACTICE ACTIVITIES

- Read rhythms in rhythm names, inner hearing the triplets, while conducting
- Compose rhythms using triplets then read in rhythm names while conducting
- Sing the Mixolydian mode in solfa with handsigns
- Sing all known scales and modes in solfa with handsigns, descending then ascending.
- Sing the Mixolydian mode in letter names in various keys up to 3# and b
- Sing the consecutive intervals within the Mixolydian mode.
- Sing Mixolydian melodies in solfa with handsigns
- Compose Mixolydian melodies then sing in solfa with handsigns
- Sing Dominant 7th chords with intervals in solfa with handsigns
- Sing Major, minor, diminished, Augmented and Suspended 4th chords with intervals in solfa with handsigns, from the same bottom note
- Compose chord progressions then sing fully

Section 12 - Rhythm



Syncopation Across Two Beats



Syncopation occurs when a weak beat, or part of a beat, is accented.

For example, in a bar of $\frac{4}{4}$ the first beat is naturally accented the most and the third beat is slightly accented.



If we play the following rhythm:  we create a syncopated feeling.

This is due to the accent now falling on the second half of the first beat rather than on the first beat.

The rhythm names of **ti-ta-ti** or **syn-co-pa** can be used. This rhythm lasts for two beats.

Read Rhythmic Examples 53 and 54 while clapping this ostinato:  taking note of where, in the ostinato, the last quaver of this new rhythm falls.

The rhythm of the ostinato is written above the Rhythmic Example below.

 sounds the same as 



Rhythmic Example 53

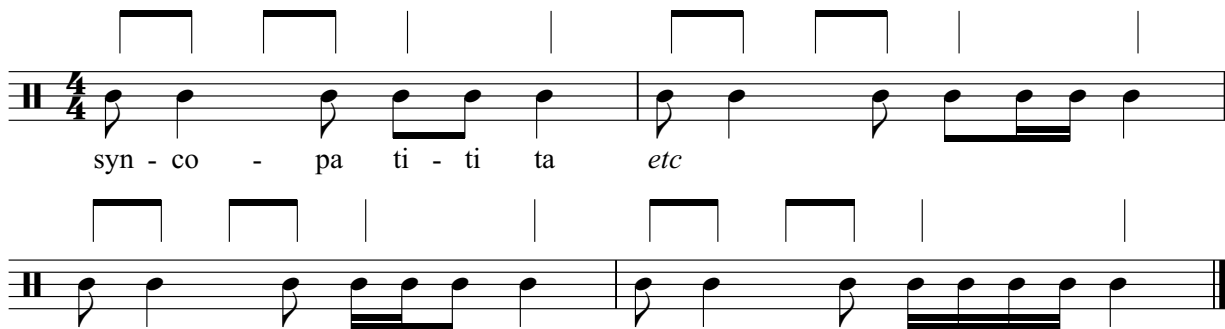



Rhythmic Example 54





Syncopation Across One Beat

 is a syncopated rhythm found in simple time consisting of a semiquaver, quaver and semiquaver. This rhythm lasts for one beat.

ka-ti - ka

Read Rhythmic Examples 55 and 56 while clapping this ostinato:  taking note of where, in the ostinato, the last semiquaver of this new rhythm falls.

The rhythm of the ostinato is written above Rhythmic Example 55 below.

 sounds the same as 



Rhythmic Example 55



ka-ti - ka ti-ka-ti-ka ka-ti - ka ti - ti etc



Rhythmic Example 56



Worksheet 67

S12 Rhythmic Transcription 1



2/89

S12 Rhythmic Transcription 2



2/90

S12 Rhythmic Transcription 3

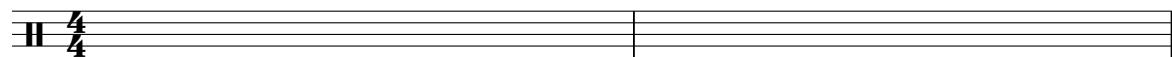

2/91

Worksheet 67 cont.

S12 Rhythmic Transcription 4

Two staves of musical notation in 4/4 time. The first staff contains rhythmic notation with stems and flags, including a triplet of eighth notes marked with a '3' and a '+' sign above it. The second staff contains stems with flags and rests, including a '+' sign above a bar and a '-' sign above a bar.

2/92

S12 Rhythmic Recognition

Drum notation for Tambourine and Bass Drum in 3/4 time. The Tambourine part has a 3/4 time signature and consists of eighth and quarter notes. The Bass Drum part has a 3/4 time signature and consists of quarter and eighth notes.

2/93

Drum notation consisting of two staves with stems and flags, representing a complex rhythmic pattern.

Drum notation in 3/4 time, labeled A and B, showing two different rhythmic patterns.

Drum notation in 3/4 time, labeled C and D, showing two different rhythmic patterns.

Drum notation in 3/4 time, labeled E and F, showing two different rhythmic patterns.

S12 Rhythmic Theory 1 Add two notes and one rest to complete each bar in the following excerpt. No two bars may be the same.

Four bars of musical notation in 4/4 time. The first bar has eighth notes. The second bar has a triplet of eighth notes marked with a '3'. The third bar has a dotted quarter note and an eighth note. The fourth bar has eighth notes.

S12 Rhythmic Theory 2 Add a time signature to the beginning of each of the following bars.

Four bars of musical notation. The first bar has eighth notes. The second bar has a triplet of eighth notes marked with a '3'. The third bar has eighth notes. The fourth bar has eighth notes and a 7-measure rest marked with a '7' over a vertical line.

Section 12 - Scales



Follow the steps in this flow chart to determine the tonality of the "Practice Question 16".

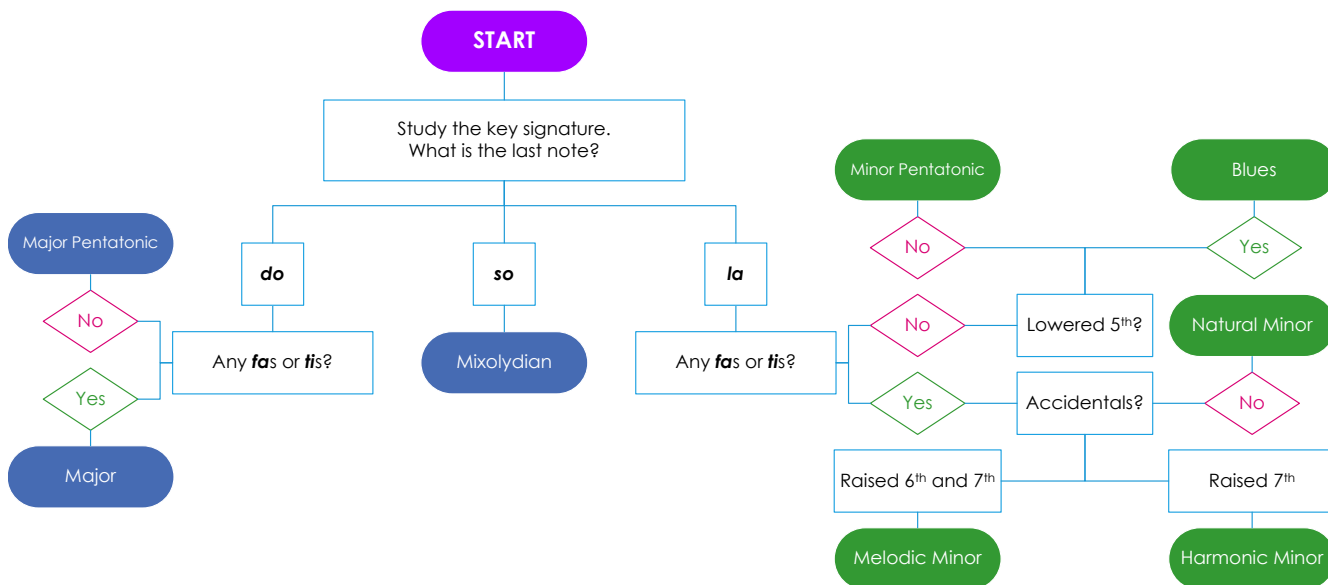

Practice Question 16: Visual Key Recognition (Part 2)



- Study the key signature of this melody. What is the last note?** The two sharps: F \sharp and C \sharp in the key signature indicate that D is *do*. This means the last note: B is ***la***.
- Are there any *fas* or *tis*?** **No** When B is *la*, *ti* is C \sharp and *fa* is G. Neither of these notes occurs in this melody.
- Is there a lowered 5th?** **Yes** The 5th note above B is F \sharp (*mi*) and there is an F \natural (*mau*) in several bars therefore, this melody is based on the **B blues scale**.



Worksheet 68

Visual Key Recognition Instructions Follow the process given in Practice Question 16 to determine the tonality of each of the following melodies. Circle the correct tonality from the choices given.

S12 Visual Key Recognition 1



Scale form: melodic minor Major Pentatonic harmonic minor Major minor pentatonic

S12 Visual Key Recognition 2

Scale form: melodic minor Major Pentatonic harmonic minor Major minor pentatonic

S12 Visual Key Recognition 3

Scale form: Major pentatonic blues harmonic minor melodic minor Major Mixolydian

S12 Scales 1 Beginning on the tonic notes indicated, and using the rhythmic value of that note, write the ascending scale indicated. Use a key signature and accidentals as required and identify the intervals between each pair of notes.

a. The natural minor scale

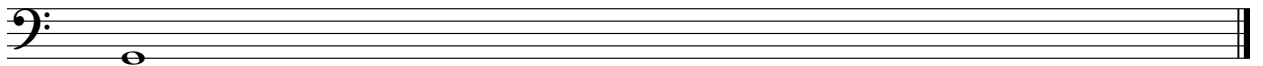

b. The melodic minor scale

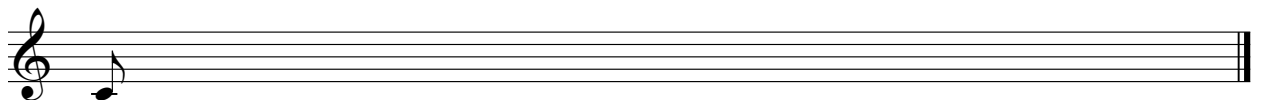

c. The Mixolydian Mode

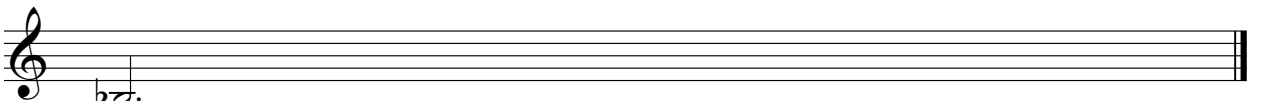

S12 Scales 2 Three scales will be played twice each. They will be either Major Scale, Mixolydian Mode, blues scale, harmonic minor or melodic minor. Write the name of each scale you hear in the spaces provided.

1.

2.

3.

Section 12 - Intervals

Worksheet 69

S12 Intervals 1 A melody will be played several times. The rhythm of this melody is printed below. Identify the first and last intervals (quality and number) and write your answers beneath the brackets and circle the tonality of the melody below.

Scale form: melodic minor Major Pentatonic harmonic minor Major

S12 Intervals 2 Identify the bracketed intervals in the following melodies. Write your answers (quality and number) beneath the brackets. Identify the scale this melody is based on and write your answer in the space provided.

Scale: _____

Scale: _____

S12 Intervals 3 Write the intervals indicated.

Major 6th
below

Augmented 7th
below

Augmented 5th
above

Major 3rd
above

Major 2nd
below

S12 Intervals 4 Name these intervals.

S12 Intervals 5 Six intervals will be played twice. Name the intervals you hear.

1. 2. 3. 4. 5. 6.

Section 12 - Melody

S

Worksheet 70

E

S12 Melodic Transcription

2/97

S12 Melodic Recognition

2/98

Section 12 - Chords

The Major 7th Chord

The **Major 7th** chord (in root position) is made up of a root note and the notes a Major 3rd, a Perfect 5th and a Major 7th above the root note.

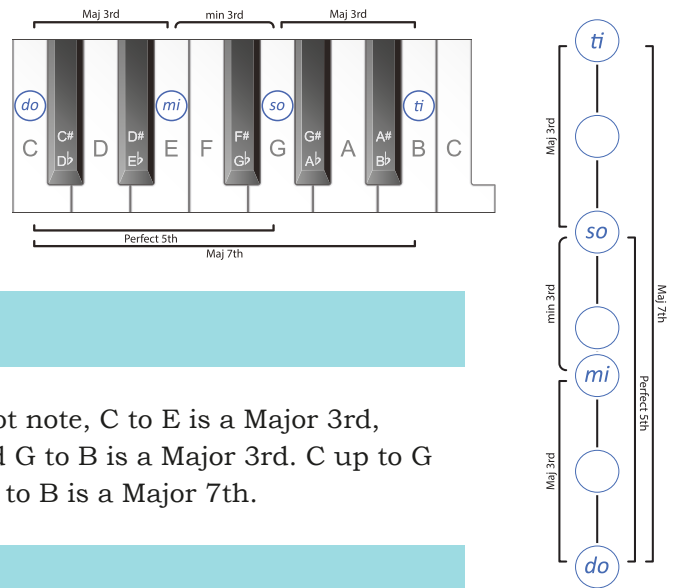

Intervals within a Major 7th Chord

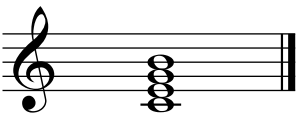

In this chord, C is the root note, C to E is a Major 3rd, E to G is a minor 3rd and G to B is a Major 3rd. C up to G is a Perfect 5th and C up to B is a Major 7th.

Labelling Major 7th Chords

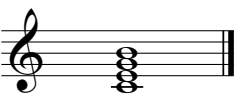

Chord Name: C Major 7th (it is the Major 7th chord built on C).

Roman numeral with Figures: Chord I⁷ in C Major (UPPERCASE, meaning Major, the Roman numeral 1 showing the scale degree the chord is built on, with the small seven representing all the figures: $\frac{7}{3}$ indicating that the chord has a 7th, 5th and 3rd above the root note).

Major 7th Chords - in Major and Minor Keys

Major 7th Chords can be built on the 1st and 4th scale degrees of a Major scale:

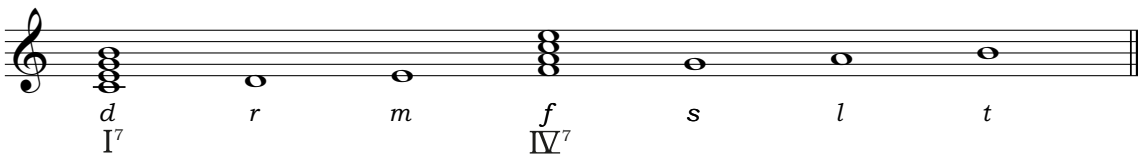

t	m'
s	d'
m	l
d	f
I^7	IV^7

and on the 6th scale degree of a harmonic minor scale:

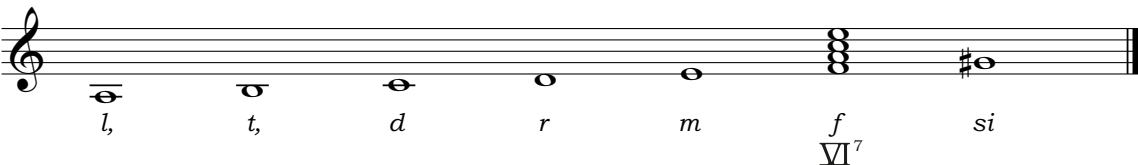

m'
d'
l
f
VI^7

The structure of the 3rds found in a Major 7th chord is **Major, minor, Major**

C Major 7th Chord Melodically

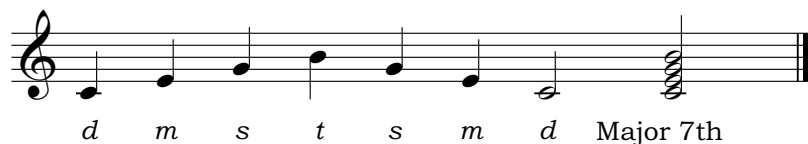



Intervals in the (C) Major 7th Chord

d m s t t s m d Major 7th
m s minor 3rd, *s t* Major 3rd, *d s* Perfect 5th, *d t* Major 7th.

Worksheet 71

S12 Chords 1 Write a Major 7th chord on each of the given notes using accidentals where necessary.

S12 Chords 2 Write a Major 7th chord **below** each of the given notes using accidentals where necessary.

S12 Chords 3 In the keys indicated, write and name the specified chords.

Tonic 7	Dominant sus 4	Submediant 7	Dominant 7
A Major	E \flat Major	F harmonic minor	E harmonic minor

S12 Chords 4 Write the Major 7th chord built on the 4th scale degree in the Major keys with the following key signatures.

S12 Chords 5 Five chords will be played twice. They will be diminished or suspended 4th triads or the Dominant 7th or Major 7th chords. Write the quality of each chord in the spaces provided.

1. 2. 3. 4. 5.

Section 12 - Chord Progressions



Chord Charts for Transcriptions - including the Major 7th Chord

Here are all triads, the Dominant 7th and the Major 7th chords in a Major key (C Major) on the staff and in transcription chord chart form:

Major Scale Chord Progression Transcription Chart Example (G Major)

G	A	B	C	D	E	F#
<i>d</i>	<i>r</i>	<i>m</i>	<i>f</i>	<i>s</i>	<i>l</i>	<i>t</i>
I	ii	iii	IV	V	vi	vii°
I ⁷			IV ⁷	V ⁷		

and in a harmonic minor key (A minor):

Minor Scale Chord Progression Transcription Chart Example (E minor)

E	F#	G	A	B	C	D#
<i>l,</i>	<i>t,</i>	<i>d</i>	<i>r</i>	<i>m</i>	<i>f</i>	<i>si</i>
i	ii°	III ⁺	iv	V	VI	vii°
				V ⁷	VI ⁷	



Major Chord Chart - Practice Version (Triads, Dominant & Major 7ths)

	<i>t</i>				<i>m</i>		<i>f</i>		
<i>s</i>	<i>s</i>	<i>l</i>	<i>t</i>	<i>d'</i>	<i>d'</i>	<i>r'</i>	<i>r'</i>	<i>m'</i>	<i>f</i>
<i>m</i>	<i>m</i>	<i>f</i>	<i>s</i>	<i>l</i>	<i>l</i>	<i>t</i>	<i>t</i>	<i>d'</i>	<i>r'</i>
<i>d</i>	<i>d</i>	<i>r</i>	<i>m</i>	<i>f</i>	<i>f</i>	<i>s</i>	<i>s</i>	<i>l</i>	<i>t</i>
I	I ⁷	ii	iii	IV	IV ⁷	V	V ⁷	vi	vii°



Harmonic Minor Chord Chart - Practice Version (Triads, Dominant & Major 7ths)

	<i>l</i>				<i>r'</i>		<i>m'</i>	
<i>m</i>	<i>f</i>	<i>si</i>	<i>l</i>	<i>t</i>	<i>t</i>	<i>d'</i>	<i>d'</i>	<i>r'</i>
<i>d</i>	<i>r</i>	<i>m</i>	<i>f</i>	<i>si</i>	<i>si</i>	<i>l</i>	<i>l</i>	<i>t</i>
<i>l,</i>	<i>t,</i>	<i>d</i>	<i>r</i>	<i>m</i>	<i>m</i>	<i>f</i>	<i>f</i>	<i>si</i>
i	ii ^o	III ⁺	iv	V	V ⁷	VI	VI ⁷	vii ^o



Worksheet 72

Write the transcription chord chart out first for all chord progression transcriptions.

Chord Progression Transcription Instructions Four chord progressions, using any root position triad, Dominant 7th or Major 7th chord found in a Major or harmonic minor scale, will be played several times. The first (tonic) chord is printed at the start of each progression. Identify the chords you hear using the harmonic grid and identify the cadence in the space provided.

S12 Chord Progression 1 Cadence: _____

3/01

Harmonic Grid 1. *l* 2. 3. 4.

Bass note	C			
Quality	minor			

S12 Chord Progression 2 Cadence: _____

3/02

Harmonic Grid 1. *d* 2. 3. 4.

Bass note	C			
Quality	Major 7			

S12 Chord Progression 3 Cadence: _____

3/03

Harmonic Grid 1. *l* 2. 3. 4. 5.

Bass note	G				
Quality	minor				

S12 Chord Progression 4 Cadence: _____

3/04

Harmonic Grid 1. *d* 2. 3. 4. 5.

Bass note	B \flat				
Quality	Major				

Section 12 - Revision & Practice Questions

Theory Revision

W

S12 Write the following rhythm in $\frac{6}{8}$ and $\frac{3}{4}$ correctly grouping the notes.

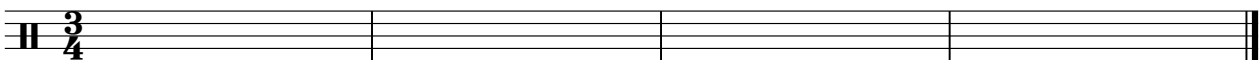
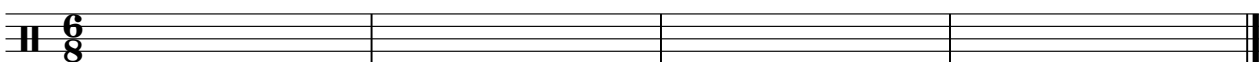

W

S12 Visual Key Recognition Instructions Determine the tonality of this melody. Circle the correct tonality from the choices given.



8



Scale form: Major Major Pentatonic harmonic minor Mixolydian minor pentatonic

P

Musicianship Practice

PRACTICE ACTIVITIES

- Read rhythms in rhythm names, clapping the syncopated rhythm, tapping all others
- Compose rhythms using syncopated rhythms then read in rhythm names
- Sing all known scales and modes in solfa with handsigns, from the same bottom note.
- Sing all 3rds found within all known scales.
- Sing Major and melodic minor melodies in solfa with handsigns
- Compose Major and melodic minor melodies then sing in solfa with handsigns
- Sing Major 7th chords with intervals in solfa with handsigns
- Sing Major, minor, diminished, Augmented, Suspended 4th triads and Dominant 7th chords with intervals in solfa with handsigns, from the same bottom note
- Sing "Major Chord Chart" in solfa with handsigns (page 156)
- Sing "Harmonic Minor Chord Chart" in solfa with handsigns (page 157)

Section 13 - Rhythm



The Dotted Quaver in Compound Time

These six new rhythms are all combinations of a dotted quaver (lasting for one and a half pulses), a semiquaver (lasting for half a pulse) and a quaver (lasting for one pulse).

These three sounds together lasts for one dotted crotchet beat in total.

tim - ka-ti	ka-tim - ti	t tim ka	ti - ka tim	ka-ti-tim	tim - ti - ka

Read Rhythmic Example 57 while clapping this ostinato:

The rhythm of the ostinato is written above the Rhythmic Example below.

sounds the same as

tim - ka-ti



Rhythmic Example 57

tim - ka-ti ti - ti - ti etc			



Read Rhythmic Example 58 while clapping this ostinato:

The rhythm of the ostinato is written above the Rhythmic Example below.

sounds the same as

ka-tim - ti



Rhythmic Example 58

ka-tim - ti ti ta etc			

Read Rhythmic Example 59 while clapping this ostinato:

The rhythm of the ostinato is written above the Rhythmic Example below.

sounds the same as

ti-tim - ka





Rhythmic Example 59

ti-tim - ka tam etc			

S



Read Rhythmic Example 60 while clapping this ostinato: 

The rhythm of the ostinato is written above the Rhythmic Example below.

 sounds the same as 
ti - ka - tim



M

Rhythmic Example 60



ti - ka - tim ti - ti - ti etc



Read Rhythmic Example 61 while clapping this ostinato: 

The rhythm of the ostinato is written above the Rhythmic Example below.

 sounds the same as 
ka - ti - tim

M



Rhythmic Example 61



ka - ti - tim ti - ti - ti etc

S



Read Rhythmic Example 62 while clapping this ostinato: 

The rhythm of the ostinato is written above the Rhythmic Example below.

 sounds the same as 
tim - ti - ka

M

Rhythmic Example 62



tim - ti - ka ti - ka ta etc

CE

W

Worksheet 73

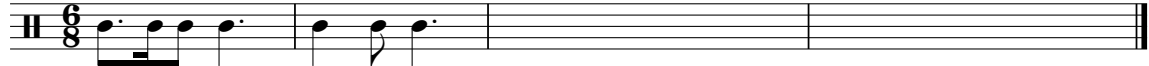
S13 Rhythmic Transcription 1

Worksheet 73 cont.

S13 Rhythmic Transcription 2

Trumpet

Horn

Tuba

3/06

S13 Rhythmic Transcription 3

3/07

S13 Rhythmic Transcription 4

Panpipes

Trumpet

Ratchet

3/08

S13 Rhythmic Transcription 5

3/09

S13 Rhythmic Transcription 6

3/10

Section 13 - Scales



Practice Question 17: Aural Tonality Recognition (Part C)

Aurally determining the key or tonality a melody is written in, when your choices are more than Major or minor, requires additional steps.

The following melody can be in one of the following tonalities:

Major	natural minor	harmonic minor	melodic minor
Major Pentatonic	minor pentatonic	blues	Mixolydian Mode

3/11

1. Consider the main differences between the tonalities given. Each of the above tonalities can be considered either *do* or *la* based. Therefore, the first time you hear the melody decide what the last note sounds like in solfa: *do* or *la*. Patterns such as *mi re do* or *do ti, la*, can help determine this.

do based tonalities are: Major, Major Pentatonic and Mixolydian.

la based tonalities are: natural, harmonic and melodic minor, minor pentatonic and blues scale.

The opening bar has a tonic/dominant sound which could be either Major (*do so*) or minor (*la mi*). The second bar sounds strange with a note that perhaps doesn't "belong". The third bar clearly outlines the tonic triad of a **Major** tonality. The fourth bar again has an odd note but overall sounds *do* based.

This melody can be considered *do* based (however, you may have already recognised a note that does **not** belong in a Major scale).

2. Next, consider the differences between the three *do* based tonalities:

Major Pentatonic will sound the same as Major, without *fa* or *ti* therefore can include no semitones.

Mixolydian will sound the same as Major, with a lowered 7th note (*ti* becomes *taw*). The interval between the tonic and 7th note can help here: is it a semitone (*ti*) or a tone (*taw*)

The strange note in the second bar is the lowered 7th: *taw* therefore, this melody is in a **Mixolydian** tonality.

3. If this melody had been *la* based, you would have needed to consider the differences between the five *la* based tonalities:

Natural minor - the melody has **no** raised 6th (*fi*) or 7th (*si*) notes

Harmonic minor - the melody has a **raised 7th** (*si*) every time this note is played and also has the Augmented 2nd (*fa* to *si*) which has a distinctive sound.

Melodic minor - the melody has a raised 6th (*fi*) and 7th (*si*) and the natural version of these notes (*fa* and *so*)

Minor pentatonic - the melody includes no semitones (it has no *fa* or *ti*)

Blues - melody includes the dominant AND flattened dominant (*mi* and *maw*) notes

Worksheet 74

S13 Scales 1 Write the key signatures of the following scales.

F Major F Mixolydian F minor D Major D minor D Mixolydian G^b Major

Worksheet 74 cont.

S13 Aural Tonality Recognition Instructions

Listen to the following melodies which will be played three times each.
Circle the correct tonality of each melody.

S13 Aural Tonality Recognition 1

Major minor pentatonic blues Mixolydian

3/12

S13 Aural Tonality Recognition 2

Major Major pentatonic minor pentatonic Mixolydian

3/13

S13 Aural Tonality Recognition 3

Major Major pentatonic melodic minor blues Mixolydian

3/14

S13 Aural Tonality Recognition 4

Major natural minor melodic minor blues Mixolydian

3/15

S13 Scales 2 Three scales will be played twice. They will be one of the following:

Major Major Pentatonic harmonic minor blues melodic minor Mixolydian
Identify each scale in the spaces provided.

3/16

1. _____ 2. _____ 3. _____

S13 Key Recognition Write the tonality (key) for the following melodies in the space provided.
List three elements in each melody that indicate this choice.

Tonality: _____ Element 1: _____
Element 2: _____ Element 3: _____

Tonality: _____ Element 1: _____
Element 2: _____ Element 3: _____

Section 13 - Intervals



Worksheet 75

S13 Intervals 1 Name the scale and label intervals (using "tone" or "semitone") between each pair of notes in the scales below.

Scale: _____

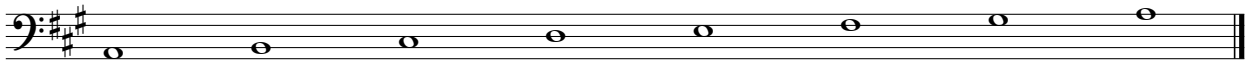

S13 Intervals 2 A melody will be played several times. The rhythm of this melody is printed below. Identify the first and last intervals (quality and number) and write your answers beneath the brackets and circle the tonality of the melody below.



Scale form: melodic minor Major Pentatonic Mixolydian harmonic minor Major

S13 Intervals 3 A melody will be played several times. The rhythm of this melody is printed below. Identify the first and last intervals (quality and number) and write your answers beneath the brackets and circle the tonality of the melody below.



Scale form: natural minor minor pentatonic harmonic minor Major Mixolydian

S13 Intervals 4 Name these intervals. Use the term "compound" for intervals larger than an octave.

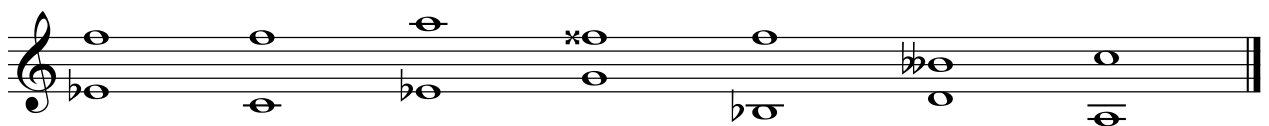

S13 Intervals 5 Write the following intervals.



Major 6th
above

minor 7th
below

minor 3rd
above

Aug 4th
below

Major 2nd
below

Section 13 - Melody

S

Worksheet 76

S13 Melodic Transcription 1



Panpipes

Musical notation for S13 Melodic Transcription 1, showing the Panpipes part in treble clef and the Piano accompaniment in bass clef.

3/19

S13 Melodic Transcription 2



Musical notation for S13 Melodic Transcription 2, showing the piano accompaniment in treble and bass clefs.

3/20

S13 Melodic Transcription 3



Musical notation for S13 Melodic Transcription 3, showing the piano accompaniment in treble and bass clefs.

3/21

Section 13 - Chords



The Minor 7th Chord

The **minor 7th** chord (in root position) is made up of a root note and the notes a minor 3rd, a Perfect 5th and a minor 7th above the root note.

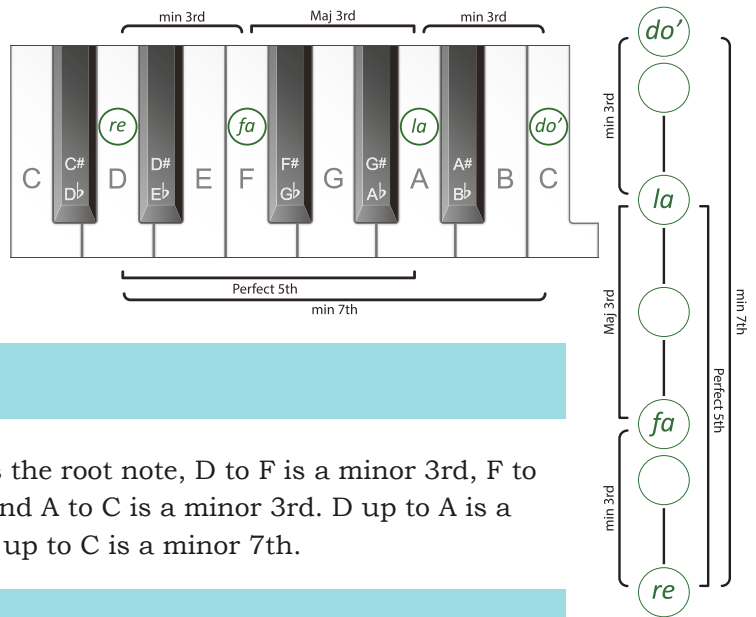

Intervals within a Minor 7th Chord

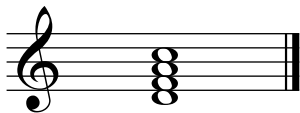

In this chord, D is the root note, D to F is a minor 3rd, F to A is a Major 3rd and A to C is a minor 3rd. D up to A is a Perfect 5th and D up to C is a minor 7th.

Labelling Minor 7th Chords

Chord Name: D minor 7th (it is the minor 7th chord built on D)

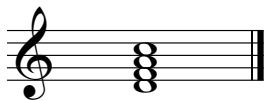

Roman numeral with Figures: Chord ii⁷ in C Major or **Chord iv⁷** in A harmonic minor (lower case meaning minor, the Roman numeral showing the scale degree the chord is built on, with the small seven representing all the figures: $\frac{7}{3}$ indicating that the chord has a 7th, 5th and 3rd above the root note).

Minor 7th Chords - in Major and Minor Keys

Minor 7th chords can be built on the 2nd, 3rd and 6th scale degrees of a Major scale:

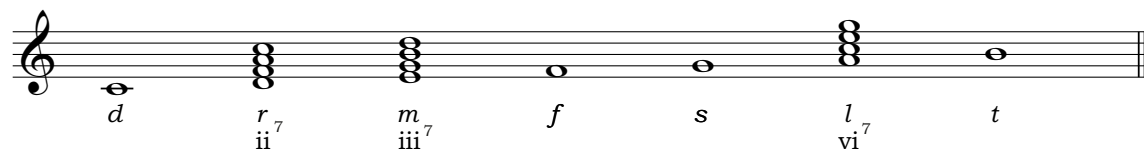

d'	r'	s'
l	t	m'
f	s	d'
r	m	l
ii ⁷	iii ⁷	vi ⁷

and on the 4th scale degrees of a harmonic minor scale:

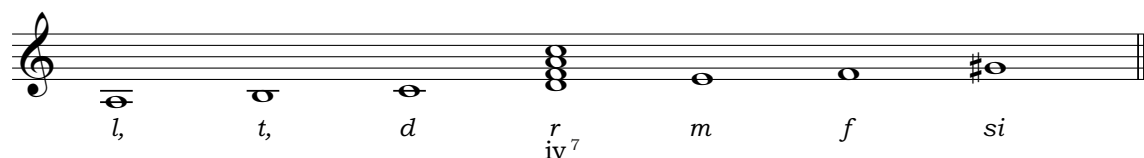

d'
l
f
r
iv ⁷

The structure of the 3rds found in a minor 7th chord is **minor, Major, minor**

D Minor 7th Chord Melodically





Intervals in the (D) Minor 7th Chord

r f l d' d' l f r minor 7th *r f* minor 3rd, 7th

f l Major 3rd, *l d'* minor 3rd, *r l* Perfect 5th, *r d'* minor 7th.



Worksheet 77

S13 Chords 1 Write a minor 7th chord on each of the given notes using accidentals where necessary.

S13 Chords 2 Write a minor 7th chord below each of the given notes using accidentals where necessary.

S13 Chords 3 In the tonic keys indicated, write and name the specified chords.

Tonic Major 7th
E Major

Dominant
F# harmonic minor

supertonic minor 7th
A \flat Major

submediant
F Major

S13 Chords 4 Write the minor 7th chord built on the 4th scale degree in the harmonic minor keys with the following key signatures.

S13 Chords 5 Write a tonic chord in 1st inversion in the harmonic minor keys with the following key signatures.

S13 Chords 6 Five chords will be played twice.

They will be Major or minor triads or the Dominant 7th, Major 7th or minor 7th chords. Write the quality of each chord in the spaces provided.

1. _____
2. _____
3. _____
4. _____
5. _____

Section 13 - Chord Progressions



Chord Charts for Transcriptions - with the Minor 7th Chord

Here are all triads, the Dominant 7th, Major 7th and minor 7th chords in a Major key (C Major) on the staff and in transcription chord chart form:

d *d* *r* *r* *m* *m* *f* *f* *s* *s* *l* *l* *t*
 I I⁷ ii ii⁷ iii iii⁷ IV IV⁷ V V⁷ vi vi⁷ vii⁰

Major Scale Chord Progression Transcription Chart Example (F Major)

F	G	A	B \flat	C	D	E
<i>d</i>	<i>r</i>	<i>m</i>	<i>f</i>	<i>s</i>	<i>l</i>	<i>t</i>
I	ii	iii	IV	V	vi	vii ⁰
I ⁷	ii ⁷	iii ⁷	IV ⁷	V ⁷	vi ⁷	

and in a harmonic minor key (A minor):

l *t* *d* *r* *r* *m* *m* *f* *f* *si*
 i ii⁰ III⁺ iv iv⁷ V V⁷ VI VI⁷ vii⁰

Minor Scale Chord Progression Transcription Chart Example (D minor)

D	E	F	G	A	B \flat	C \sharp
<i>l</i>	<i>t</i>	<i>d</i>	<i>r</i>	<i>m</i>	<i>f</i>	<i>si</i>
i	ii ⁰	III ⁺	iv	V	VI	vii ⁰
			iv ⁷	V ⁷	VI ⁷	



Major Chord Chart - Practice (Triads, Dominant, Major & minor 7ths)

	<i>t</i>	<i>d'</i>	<i>r'</i>	<i>m'</i>	<i>f</i>	<i>s'</i>						
<i>s</i>	<i>s</i>	<i>l</i>	<i>l</i>	<i>t</i>	<i>t</i>	<i>d'</i>	<i>d'</i>	<i>r'</i>	<i>r'</i>	<i>m'</i>	<i>m'</i>	<i>f</i>
<i>m</i>	<i>m</i>	<i>f</i>	<i>f</i>	<i>s</i>	<i>s</i>	<i>l</i>	<i>l</i>	<i>t</i>	<i>t</i>	<i>d'</i>	<i>d'</i>	<i>r'</i>
<i>d</i>	<i>d</i>	<i>r</i>	<i>r</i>	<i>m</i>	<i>m</i>	<i>f</i>	<i>f</i>	<i>s</i>	<i>s</i>	<i>l</i>	<i>l</i>	<i>t</i>
I	I ⁷	ii	ii ⁷	iii	iii ⁷	IV	IV ⁷	V	V ⁷	vi	vi ⁷	vii ⁰



Harmonic Minor Chord Chart - Practice (Triads, Dominant, Major & minor 7ths)

				<i>d'</i>		<i>r'</i>		<i>m'</i>	
<i>m</i>	<i>f</i>	<i>si</i>	<i>l</i>	<i>l</i>	<i>t</i>	<i>t</i>	<i>d'</i>	<i>d'</i>	<i>r'</i>
<i>d</i>	<i>r</i>	<i>m</i>	<i>f</i>	<i>f</i>	<i>si</i>	<i>si</i>	<i>l</i>	<i>l</i>	<i>t</i>
<i>l,</i>	<i>t,</i>	<i>d</i>	<i>r</i>	<i>r</i>	<i>m</i>	<i>m</i>	<i>f</i>	<i>f</i>	<i>si</i>
<i>i</i>	<i>ii</i> ^o	<i>III</i> ⁺	<i>iv</i>	<i>iv</i> ⁷	<i>V</i>	<i>V</i> ⁷	<i>VI</i>	<i>VI</i> ⁷	<i>vii</i> ^o

Worksheet 78

Write the transcription chord chart out first for all chord progression transcriptions.

Chord Progression Transcription Instructions Three chord progressions, using any root position triad or Dominant 7th, Major 7th or minor 7th chord found in a Major or harmonic minor scale, will be played several times. The first (tonic) chord is printed at the start of each progression. Identify the chords you hear using the harmonic grid and identify the cadence in the space provided.

S13 Chord Progression 1

Cadence: _____

3/23

Harmonic Grid1. *l*

2.

3.

4.

5.

6.

Bass note	B					
Quality	minor					

S13 Chord Progression 2

Cadence: _____

3/24

Harmonic Grid1. *l*

2.

3.

4.

5.

6.

Bass note	D					
Quality	minor					

S13 Chord Progression 3

Cadence: _____

3/25

Harmonic Grid1. *d*

2.

3.

4.

5.

Bass note	D				
Quality	Major				

S13 Chord Progression 4

Cadence: _____

3/26

Harmonic Grid1. *l*

2.

3.

4.

5.

Bass note	E				
Quality	minor				

Section 14 - Rhythm



The Duplet



A duplet is defined as two notes played in the time of three.

dup-let



Quaver Duplet in Compound Time

In compound time there are usually three quavers on a beat:

A quaver duplet occurs when two quavers are played on one beat - two played in the time three would normally be played:

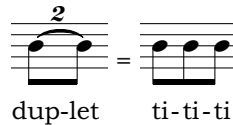

dup-let ti-ti-ti



Rhythmic Example 63

A Syncopated Rhythm in Compound Time



is another compound rhythm with two semiquavers and two quavers.

ka ti ti ka

Read Rhythmic Example 64 while clapping this ostinato:

The rhythm of the ostinato is written above the Rhythmic Example below.

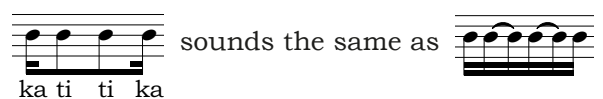

ka ti ti ka



Rhythmic Example 64



Ties in Transcriptions

A tie is a curved line joining the rhythmic values of two notes of the same pitch. In a transcription exercise, if you hear a sound that extends across a bar line then it is most likely two notes tied together or a rest.

Ties are most frequently used across barlines where the rhythm cannot be written as a single note.



Rhythmic Example 65

ta ti-ti ti-ka-ti ta - i-ti etc



Worksheet 79

S14 Rhythmic Transcription 1

S14 Rhythmic Transcription 2

S14 Rhythmic Transcription 3

S14 Rhythmic Transcription 4

S14 Rhythmic Transcription 5

Worksheet 79 cont.

S14 Rhythmic Transcription 6

3/32

S14 Rhythmic Transcription 7

3/33

S14 Rhythmic Transcription 8

3/34

Section 14 - Scales



The Dorian Mode

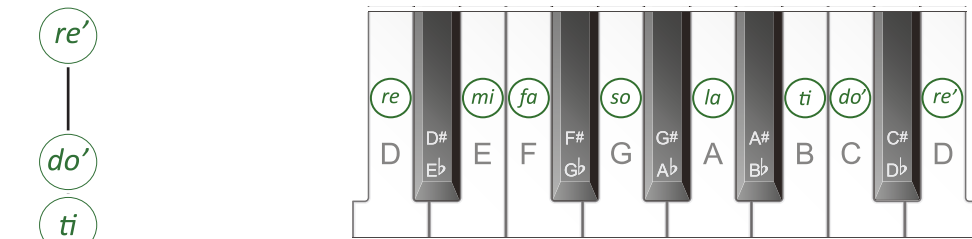

Dorian - Authentic



The interval pattern of the dorian mode can be found by playing the white notes on a piano starting on D or by singing the notes of a Major scale in solfa starting on *re*. Notice that the semitones are still found between *mi* and *fa* and *ti* and *do'* as marked by the slurs in the following scale.

Dorian Mode on D - Authentic

Dorian Mode in D Natural Minor - Altered (with a raised 6th)

The D dorian mode is almost identical to D natural minor except that it has an $B\sharp$ instead of a $B\flat$. Therefore, *la* is an alternate tonic note, as in D natural minor with the raised 6th note i.e. *fa* becomes *fi*:

Dorian Mode in D (Natural Minor) - Altered



The Lydian Mode

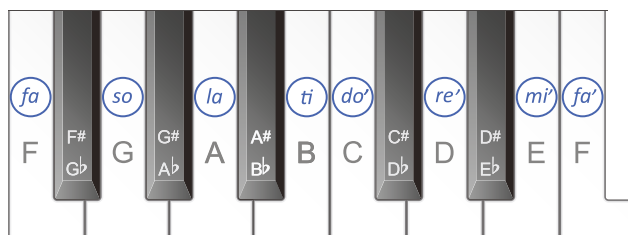

The interval pattern of the Lydian mode can be found by playing the white notes on a piano starting on F or by singing the notes of a Major scale in solfa starting on *fa*. Notice that the semitones are still found between *mi* and *fa* and *ti* and *do'* as marked by the slurs in the following scale.

Lydian - Authentic

fa
mi
re
do
ti,
la,
so,
fa,

Lydian Mode on F - Authentic

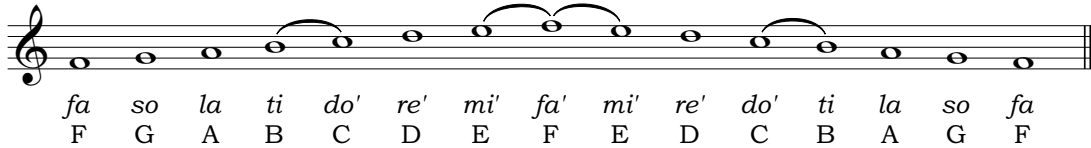

Lydian Mode in F (Major) - Altered (with a raised 4th)

The F Lydian mode is almost identical to F Major except that it has a B \sharp instead of a B \flat . Therefore, *do* is an alternate tonic note, as in F Major with the raised 4th note i.e. *fa* becomes *fi*:

Lydian Mode in F (Major) - Altered

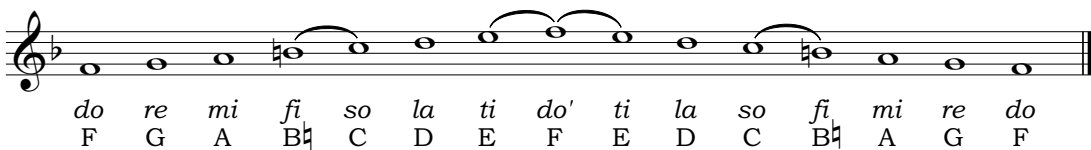

Lydian - Altered

do'
ti
la
so
fi
mi
re
do

W

Worksheet 80

S14 Scales 1 Read the following statement then write one octave ascending of the dorian mode beginning on A in semibreves. Show the semitones with slurs and use a key signature.

If A = *re* then G = *do* and the key signature of G Major is 1 sharp: F \sharp

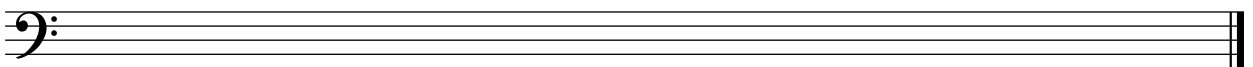

S14 Scales 2 Complete the following statement then write one octave descending of the dorian mode with the following key signature in crotchets. Label the consecutive intervals below the staff.

If B \flat = *re* then ___ = *do* and the key signature of _____ is _____

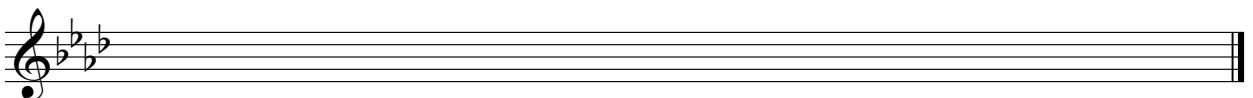

S14 Scales 3 Complete the following statement then write one octave ascending and descending of the Lydian Mode beginning on B \flat . Use minims and show the semitones with slurs.

If B \flat = *fa* then ___ = *do* and the key signature of _____ is _____

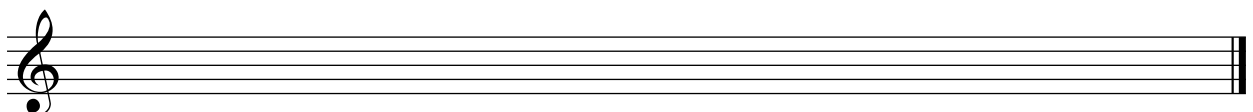

Worksheet 80 cont.

S14 Scales 4 Complete the following statement then write one octave ascending of the Lydian Mode with the following key signature in whole notes. Identify the interval between each consecutive pair of notes.

If A = *fa* then ___ = *do* and the key signature of _____ is _____

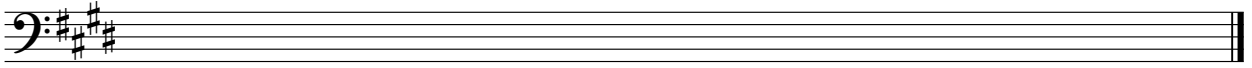

S14 Scales 5 Without a key signature, write one octave ascending of the Mixolydian Mode beginning on, and using the value of, the following note.

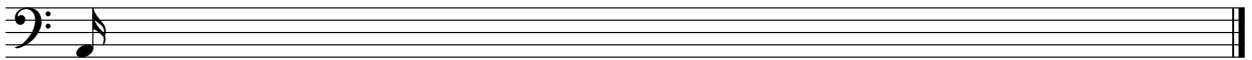

S14 Scales 6 Without a key signature, write one octave descending of the blues scale beginning on, and using the value of, the following note.

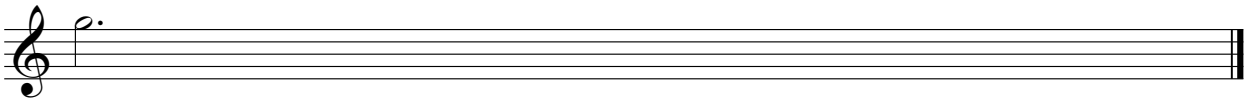

S14 Scales 7 Without a key signature, write one octave ascending of the Major Pentatonic Scale beginning on the following note.

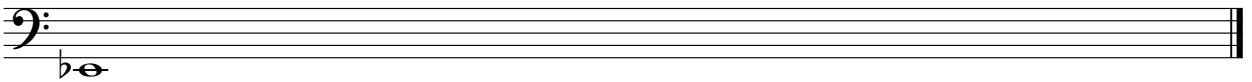

S14 Scales 8 Write the following scales and/or modes, beginning on the given note and using the rhythmic value of the given note.

a. The minor pentatonic scale, one octave, descending.

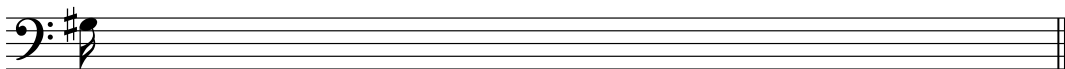

b. The Major scale, one octave, ascending and descending.

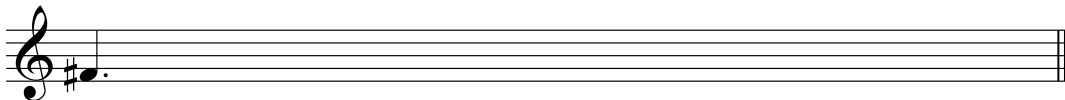

c. The Lydian mode, one octave, descending.

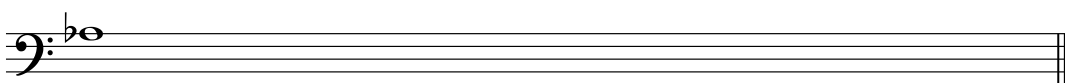

S14 Aural Tonality Recognition

Listen to the following melody which will be played three times. Circle the correct tonality.

Major harmonic minor melodic minor blues Mixolydian dorian

Section 14 - Intervals

Dorian Mode

Intervals within the Dorian Mode

Lydian Mode

Dorian Mode

Intervals within the Lydian Mode

Lydian Mode

Worksheet 81

S14 Intervals 1 A melody will be played several times. The rhythm of this melody is printed below. Identify the first and last intervals (quality and number) and write your answers beneath the brackets and circle the tonality of the melody below.

Scale form: harmonic minor Major dorian mode melodic minor

S14 Intervals 2 A melody will be played several times. The rhythm of this melody is printed below. Identify the first and last intervals (quality and number) and write your answers beneath the brackets and circle the tonality of the melody below.

Scale form: Mixolydian Mode Major dorian mode Lydian Mode blues

S14 Intervals 3 Write these intervals above the given notes.

Section 14 - Melody



Follow the steps in this flow chart to determine the tonality of the "Rumanian Canon".

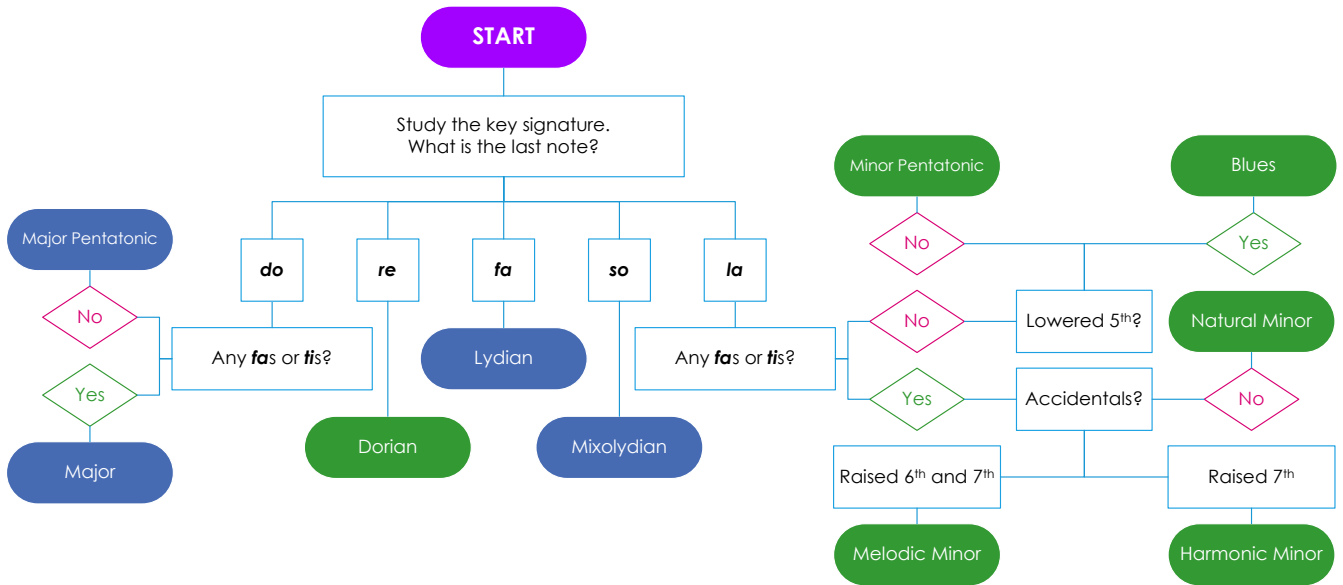

Rumanian Canon

1. 2.

Au hen c: r r l l t l t s l l f f etc
 A ered l, l, m m fi m fi r m m d d etc
 Na ura M nor:

3.

Dorian Mode - Authentic

re'
do'
ti
la
so
fa
mi
re

Dorian Mode - Altered

la
so
fi
mi
re
do
ti
la

Study the key signature of this melody. What is the last note?

The two sharps: F# and C# in the key signature indicate that D is *do*. This means the last note: E is *re*.

Therefore, the "Rumanian Canon" is based on the **E dorian mode**.

The solfa written under the notes of the "Canon" is shown in both **authentic** (*re* as the tonic):

r m f s l t d r d t l s f m r
 E F# G A B C# D E D C# B A G F# E

and **altered** Major versions (*la* as the tonic with raised 6th):

l, t, d r m fi s l s fi m r d t, l,
 E F# G A B C# D E D C# B A G F# E

Sing the dorian mode then the "Rumanian Canon" using both versions of the solfa, with hand signs.



Worksheet 82

S14 Melodic Transcription 1

3/38

S14 Melodic Transcription 2

3/39

S14 Melodic Transcription 3

3/40

Section 14 - Chords



The Half Diminished (7th) Chord

The **half diminished** chord (in root position) is made up of a root note and the notes a minor 3rd, a diminished 5th and a minor 7th above the root note.

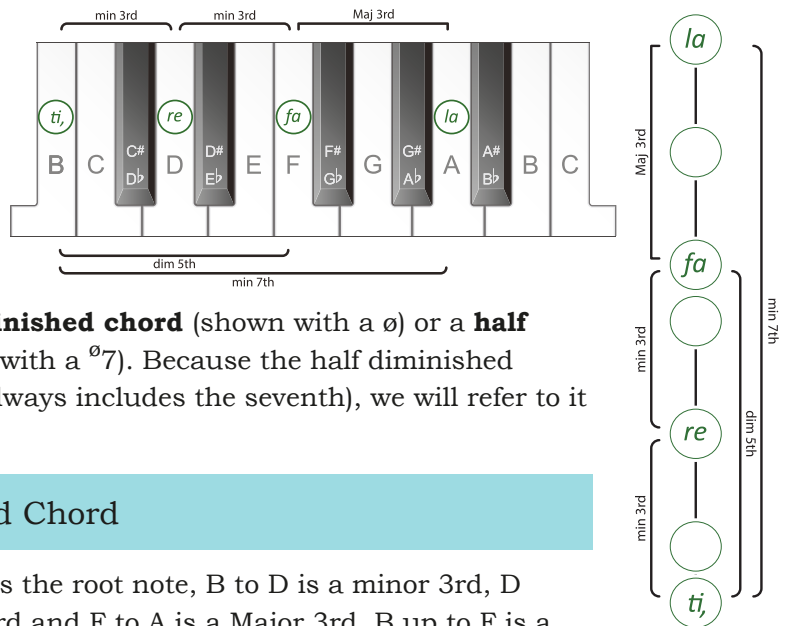

This chord can be called a **half diminished chord** (shown with a \emptyset) or a **half diminished seventh chord** (shown with a $\emptyset 7$). Because the half diminished chord **must** be a seventh chord (it always includes the seventh), we will refer to it as a **half diminished chord** (\emptyset).

Intervals within a Half Diminished Chord

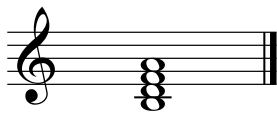

In this chord, B is the root note, B to D is a minor 3rd, D to F is a minor 3rd and F to A is a Major 3rd. B up to F is a diminished 5th and B up to A is a minor 7th.

Labelling Half Diminished Chords

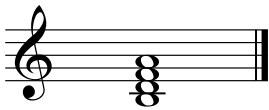

Chord Name: B half diminished (it is the half diminished chord built on B)

Roman numeral with Figures: Chord vii^o in C Major or **Chord ii^o** in A harmonic minor (lower case with the small circle split in half by a line, meaning half diminished, the Roman numeral showing the scale degree the chord is built on).

Half Diminished Chords - in Major and Minor Keys

Half diminished chords can be built on the 7th scale degrees of a Major scale:

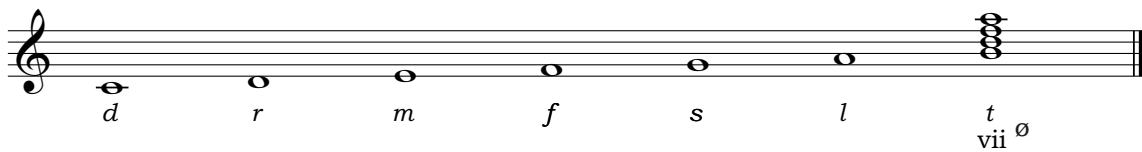

l
f
r
t
vii ^o

and on the 2nd scale degrees of a harmonic minor scale:

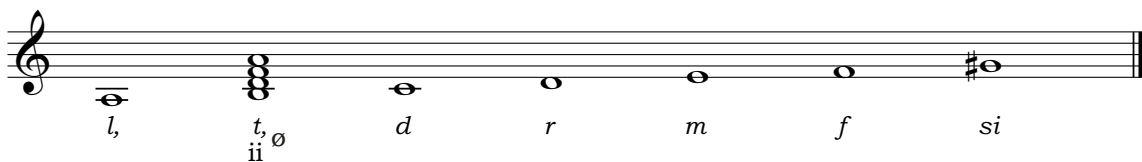

l
f
r
t
ii ^o

The structure of the 3rds found in a half diminished chord is **minor, minor, Major**

B Half Diminished 7th Chord Melodically





Intervals in the (B) Half Diminished 7th Chord

t, r f l l f r t, half diminished *t, r minor 3rd,*
r f minor 3rd, f l Major 3rd, t, f diminished 5th, t l minor 7th.

Worksheet 83

S14 Chords 1 Write a half diminished chord on each of the given notes using accidentals where necessary.

S14 Chords 2 Write a half diminished chord **below** each of the given notes using accidentals where necessary.

S14 Chords 3 Write the half diminished chord built on the 7th scale degree in the Major keys with the following key signatures.

S14 Chords 4 Write a supertonic half diminished chord in the harmonic minor keys with the following key signatures.

S14 Chords 5 Complete the following chart.

Chord	Lowest 3rd quality	Middle 3rd quality	Highest 3rd quality
Dominant 7	Major	minor	minor
Major 7			
minor 7			
half diminished			

S14 Chords 6 Five chords will be played twice.

They will be Major, minor or diminished triads or the Dominant 7th or half diminished chords. Write the quality of each chord in the spaces provided.

1. _____
2. _____
3. _____
4. _____
5. _____

Section 14 - Chord Progressions

W Chord Charts for Transcriptions - with the Half Diminished Chord

Here are all triads, the Dominant 7th, Major 7th, minor 7th and half diminished chords in a Major key (C Major) on the staff and in transcription chord chart form:

d *d* *r* *r* *m* *m* *f* *f* *s* *s* *l* *l* *t* *t*
 I I⁷ ii ii⁷ iii iii⁷ IV IV⁷ V V⁷ vi vi⁷ vii⁰ vii⁰

Major Scale Chord Progression Transcription Chart Example (D Major)

D	E	F#	G	A	B	C#
<i>d</i>	<i>r</i>	<i>m</i>	<i>f</i>	<i>s</i>	<i>l</i>	<i>t</i>
I	ii	iii	IV	V	vi	vii ⁰
I ⁷	ii ⁷	iii ⁷	IV ⁷	V ⁷	vi ⁷	vii ⁰

and in a harmonic minor key (A minor):

l *t* *t* *d* *r* *r* *m* *m* *f* *f* *si*
 i ii⁰ ii⁰ III⁺ iv iv⁷ V V⁷ VI VI⁷ vii⁰

Minor Scale Chord Progression Transcription Chart Example (B minor)

B	C#	D	E	F#	G	A#
<i>l</i>	<i>t</i>	<i>d</i>	<i>r</i>	<i>m</i>	<i>f</i>	<i>si</i>
i	ii ⁰	III ⁺	iv	V	VI	vii ⁰
	ii ⁰		iv ⁷	V ⁷	VI ⁷	

Major Chord Chart - Practice (Triads and 7ths)

	<i>t</i>		<i>d'</i>		<i>r'</i>		<i>m</i>		<i>f</i>		<i>s'</i>		<i>l'</i>
<i>s</i>	<i>s</i>	<i>l</i>	<i>l</i>	<i>t</i>	<i>t</i>	<i>d'</i>	<i>d'</i>	<i>r'</i>	<i>r'</i>	<i>m'</i>	<i>m'</i>	<i>f'</i>	<i>f'</i>
<i>m</i>	<i>m</i>	<i>f</i>	<i>f</i>	<i>s</i>	<i>s</i>	<i>l</i>	<i>l</i>	<i>t</i>	<i>t</i>	<i>d'</i>	<i>d'</i>	<i>r'</i>	<i>r'</i>
<i>d</i>	<i>d</i>	<i>r</i>	<i>r</i>	<i>m</i>	<i>m</i>	<i>f</i>	<i>f</i>	<i>s</i>	<i>s</i>	<i>l</i>	<i>l</i>	<i>t</i>	<i>t</i>
I	I ⁷	ii	ii ⁷	iii	iii ⁷	IV	IV ⁷	V	V ⁷	vi	vi ⁷	vii ⁰	vii ⁰



Harmonic Minor Chord Chart - Practice (Triads and 7ths)

		<i>l</i>			<i>d'</i>		<i>r'</i>		<i>m'</i>	
<i>m</i>	<i>f</i>	<i>f</i>	<i>si</i>	<i>l</i>	<i>l</i>	<i>t</i>	<i>t</i>	<i>d'</i>	<i>d'</i>	<i>r'</i>
<i>d</i>	<i>r</i>	<i>r</i>	<i>m</i>	<i>f</i>	<i>f</i>	<i>si</i>	<i>si</i>	<i>l</i>	<i>l</i>	<i>t</i>
<i>l,</i>	<i>t,</i>	<i>t,</i>	<i>d</i>	<i>r</i>	<i>r</i>	<i>m</i>	<i>m</i>	<i>f</i>	<i>f</i>	<i>si</i>
<i>i</i>	<i>ii^o</i>	<i>ii^o</i>	III⁺	<i>iv</i>	<i>iv⁷</i>	V	V⁷	VI	VI⁷	<i>vii^o</i>



Worksheet 84

S14 Recognition of a Chord Progression A chord progression will be played three times. Circle the correct option. The chord progression will be one of the following:

3/42

- a. *i* - *ii^o* - *iv* - **V⁷** - *i* b. *i* - *iv⁷* - *vii^o* - **V** - *i* c. *i* - *iv* - **III⁺** - *vii^o* - **V**
- d. *i* - *iv⁷* - *vii^o* - **V⁷** - **VI** e. *i* - *iv⁷* - *i* - *vii^o* - **V** f. *i* - *ii^o* - **V** - *iv* - **V**

Write the transcription chord chart out first for all chord progression transcriptions.

Chord Progression Transcription Instructions Three chord progressions, using any root position triad or Dominant 7th, Major 7th, minor 7th or half diminished chord found in a Major or harmonic minor scale, will be played several times. The first (tonic) chord is printed at the start of each progression. Identify the chords and the cadence you hear.

S14 Chord Progression 1

Cadence: _____

3/43

Harmonic Grid1. *d*

2.

3.

4.

5.

Bass note	$E\flat$				
Quality	Major				

S14 Chord Progression 2

Cadence: _____

3/44

Harmonic Grid1. *d*

2.

3.

4.

5.

6.

Bass note	$B\flat$					
Quality	Major					

S14 Chord Progression 3

Cadence: _____

3/45

Harmonic Grid1. *d*

2.

3.

4.

5.

6.

Bass note	D					
Quality	Major					

Section 14 - Revision & Practice Questions

Theory Revision

W

S14 Intervals Name the following intervals.

(Hint: write the letter names of these then work out the interval).

S14 Chords Name these chords in relation to as many keys as possible.

W

Chord **I⁷** in C Major, chord **IV⁷** in G Major

P

Musicianship Practice

PRACTICE ACTIVITIES
• Read rhythms in rhythm names, inner hearing the duplets, while conducting
• Compose rhythms, using duplets, then read in rhythm names
• Sing the Mixolydian, dorian and Lydian modes in solfa with handsigns
• Sing all known scales in solfa with handsigns, using the sequence: 1321, 2432, 3543 etc
• Sing the consecutive intervals within the dorian and Lydian modes, in solfa with handsigns
• Sing dorian and Lydian melodies in solfa with handsigns
• Compose dorian and Lydian melodies then sing in solfa with handsigns
• Sing half diminished chords with intervals in solfa with handsigns
• Sing Major, minor, diminished, Augmented, Suspended 4th triads and Dominant 7th, Major 7th and minor 7th chords in solfa with handsigns, from the same bottom note
• Sing "Major Chord Chart" in solfa with handsigns (page 182) inner hearing the top note of each chord
• Sing "Harmonic Minor Chord Chart" in solfa with handsigns (page 183) inner hearing the lowest note of each chord

Section 15 - Rhythm



More Syncopated Rhythms in Compound Time

and are syncopated rhythms lasting for one dotted crotchet beat.

ka ti ka ti ti ka ti ka

Read Rhythmic Example 66 while clapping this ostinato:

The rhythm of the ostinato is written above the Rhythmic Example below.

sounds the same as

ka ti ka ti



Rhythmic Example 66

ka-ti - ka-ti ti-ti-ti etc



Read Rhythmic Example 67 while clapping this ostinato:

The rhythm of the ostinato is written above the Rhythmic Example below.

sounds the same as

ti ka ti ka



Rhythmic Example 67

ti-ka-ti - ka ti-ti-ka-ti etc



More Dotted Quaver Rhythms in Compound Time

and are also compound rhythms lasting for one dotted crotchet beat.

ti ka tim ka ka tim ti ka

Read Rhythmic Example 68 while clapping this ostinato:

The rhythm of the ostinato is written above the Rhythmic Example below.

sounds the same as

ti ka tim ka





Rhythmic Example 68

ti-ka-tim - ka ti-ti-ti etc





Read Rhythmic Example 69 while clapping this ostinato: 

The rhythm of the ostinato is written above the Rhythmic Example below.

 sounds the same as 
ka tim ti ka

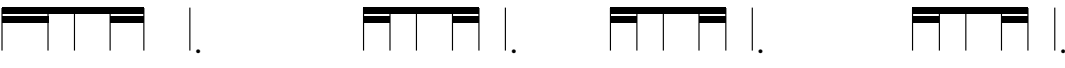

Rhythmic Example 69



ka-tim - ti-ka ti ta etc





More Rhythms in Compound Time

 and  are more compound rhythms lasting for one dotted crotchet beat.
ti ka tik ti ka ka ti ka ti ka



Read Rhythmic Example 70 while clapping this ostinato: 

The rhythm of the ostinato is written above the Rhythmic Example below.

 sounds the same as 
ti ka tik ti ka





Rhythmic Example 70



ti-ka-tik-ti - ka ti-ti-ti etc



Read Rhythmic Example 71 while clapping this ostinato: 

The rhythm of the ostinato is written above the Rhythmic Example below.

 sounds the same as 
ka ti ka ti ka



Rhythmic Example 71



ka-ti - ka-ti-ka ti-ti-ka-ti-ka etc

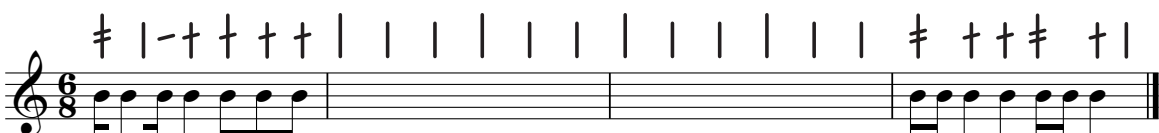

Worksheet 85

S15 Rhythmic Transcription 1



Worksheet 85 cont.

S15 Rhythmic Transcription 2

Panpipes

Clarinet

Bass

3/47

S15 Rhythmic Transcription 3

3/48

S15 Rhythmic Transcription 4

3/49

S15 Rhythmic Transcription 5

3/50

S15 Rhythmic Transcription 6

3/51

S15 Rhythmic Transcription 7

Snare Drum

Bassoon

Bass

3/52

Section 15 - Scales



Tonality Flow Chart (without a key signature)

I In a situation where key signatures are not used, it is necessary to use all other information given by the scale to determine its key or tonality. This flow chart outlines the required steps. Note that the first three steps are to determine whether the tonality is pentatonic or blues only.

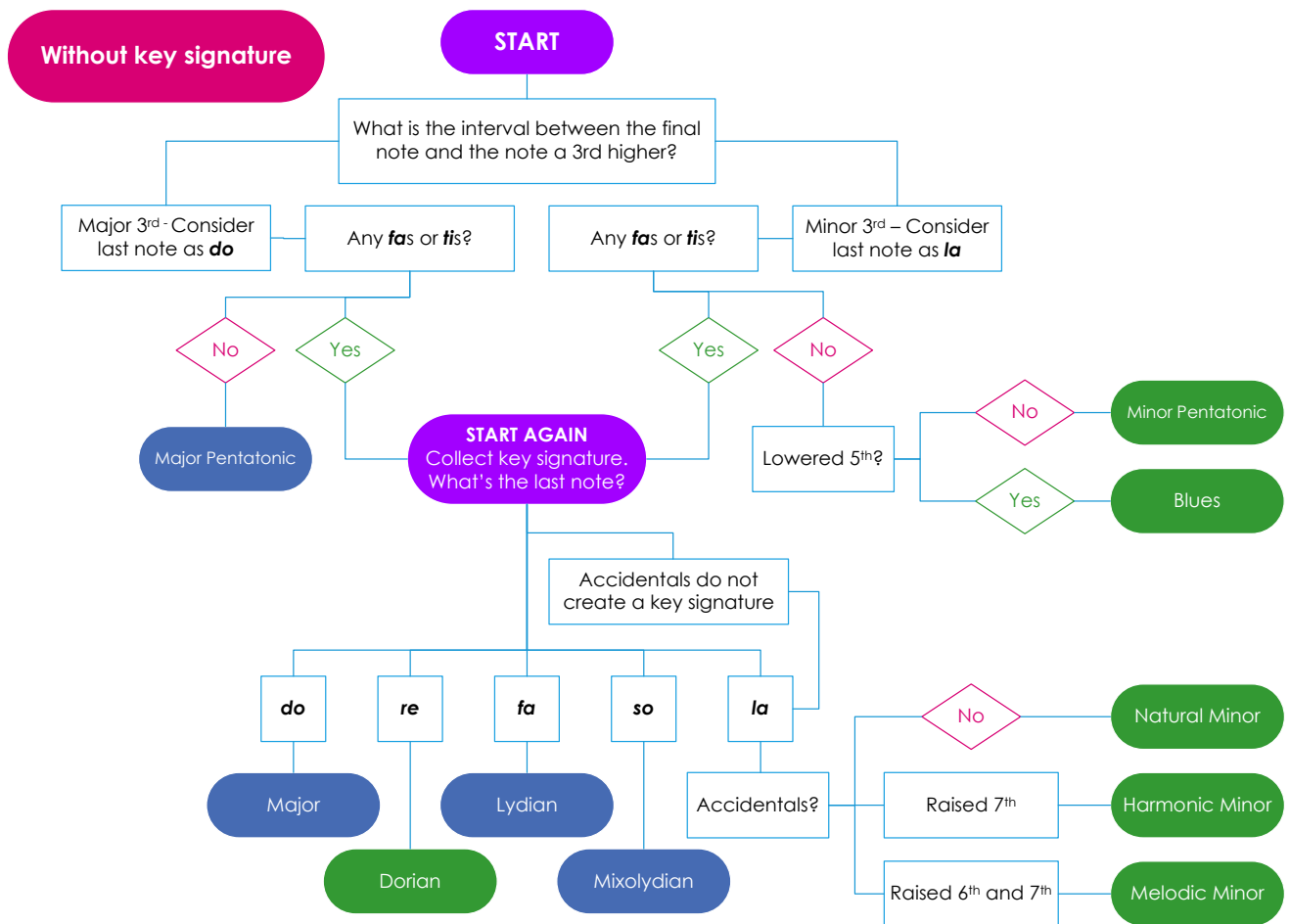

Practice Question 18: Key Recognition of a Scale without a Key Signature 1.

Name this scale.

- What is the interval between the final note and the note a 3rd higher in this scale?**
The last note of this scale is E. The note a 3rd higher than E is G, creating a minor 3rd. Therefore, consider the last note to be **la**.
- Are there any *fas* or *tis* in this scale?**
Yes *ti* is the 2nd scale degree, therefore, it cannot be a pentatonic or blues scale.
- Start again and determine the last note by collecting the key signature.**
This scale has an F \sharp and a C \sharp . These two sharps create this key signature:
This key signature tells us that **D is do** and the last note is **re**.
Therefore, this is the **E dorian mode**.

Practice Question 18: Key Recognition of a Scale without a Key Signature 2.

Name this scale. 

- What is the interval between the final note and the note a 3rd higher of this scale?**
The last note of this scale is C. The note a 3rd higher than C is E \flat , creating a minor 3rd. Therefore, consider the last note to be **la**.
- Are there any *fas* or *tis* in this scale? Yes** *ti* is the 2nd scale degree, therefore, it cannot be a pentatonic or blues scale.
- Start again and determine the last note by collecting the key signature.** This scale only has an E \flat which, by itself, cannot be a key signature.
- Are there accidentals that do not fit logically into the key signature?** When we cannot create a logical key signature from the accidentals in a scale **the last note must be *la* (C)** and the key signature for C minor (and E \flat Major) is B \flat , E \flat and A \flat .
- Is there a raised 7th? Yes** The 7th note is a B \natural (there is a B \flat in the key signature of E \flat Major).
- Is there a raised 6th? Yes** The 6th note is a A \natural (there is an A \flat in the key signature of E \flat Major) therefore this scale is the **C melodic minor scale**.

W

Worksheet 86

S15 Scales 1 Follow the flow chart on page 188 to name these scales.

a _____



b _____

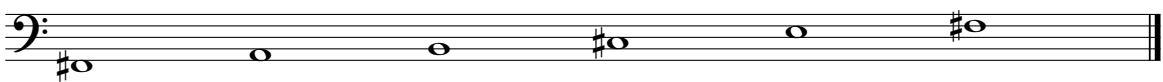

c _____



S15 Scales 2 Complete the following statements.

The three scales and modes that can be *do* based are

The six scales and modes that can be *la* based are

S15 Scales 3 Four scales will be played twice each. They will be either the Major Scale, Mixolydian Mode, dorian mode, blues scale, harmonic minor or melodic minor.

Write the name of each scale you hear in the spaces provided.

1. _____ 2. _____

3. _____ 4. _____

Section 15 - Intervals



Worksheet 87

S15 Intervals 1 Identify the bracketed intervals in the following melodies. Write your answers (quality and number) beneath the brackets.



S15 Intervals 2 Write the intervals indicated.

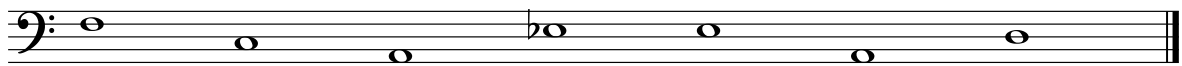

Aug 5th Below Aug 6th Above Aug 7th Above Perfect 4th Below Aug 7th Above Perfect 8ve Above Major 2nd Below

S15 Intervals 3 A melody will be played several times. The rhythm of this melody is printed below. Identify the first and last intervals (quality and number) and write your answers beneath the brackets and circle the tonality of the melody below.



Scale form: harmonic minor Major Major Pentatonic dorian mode Lydian Mode

S15 Intervals 4 A melody will be played several times. The rhythm of this melody is printed below. Identify the first and last intervals (quality and number) and write your answers beneath the brackets. Circle the tonality of the melody below.



Scale form: Mixolydian Mode Major Major Pentatonic Lydian Mode blues

S15 Intervals 5 Name these intervals.



Section 15 - Melody



Determining Tonality of a Melody without a Key Signature

Use the flow chart on page 188 to work through the steps required to determine the tonality of the melodies (without key signatures) in the next two practice questions.

Practice Question 19: Key Recognition of a Melody without a Key Signature 1.



- What is the interval between the final note and the note a 3rd higher in this melody?**
The last note of this melody is C. The note a 3rd higher than C is E \flat , creating a minor 3rd. Therefore, consider the last note to be *la*.
- Are there any *fas* or *tis* in this melody? Yes** *ti* is the 2nd scale degree and is in the first bar of this melody, therefore, it cannot be based on a pentatonic or blues scale.
- Start again and determine the last note by collecting the key signature.** This melody has a B \flat , E \flat , and an A \flat :  This key signature indicates that E \flat is *do*.
- Determine the solfa of the last note.** The last note of this melody is C. When E \flat is *do*, C is *la*.
- Is there a raised 7th? Yes** In the 2nd bar there is a B \natural which is the 7th note: B \flat raised a semitone.
- Is there a raised 6th? Yes** In the 2nd bar there is also an A \natural which is the 6th note: A \flat raised a semitone. Therefore, this melody is in **C melodic minor**.

Practice Question 19: Key Recognition of a Melody without a Key Signature 2.



- What is the interval between the final note and the note a 3rd higher in this melody?**
The last note of this melody is A. The note a 3rd higher than A is C, creating a minor 3rd. Therefore, consider the last note to be *la*.
- Are there any *fas* or *tis* in this melody? Yes** *ti* is the 2nd scale degree and is in the first bar of this melody, therefore, it cannot be based on a pentatonic or blues scale.
- Start again and determine the last note by collecting the key signature.**
This melody has an F \sharp :  This key signature indicates that G is *do*.
- Determine the solfa of the last note. The last note is *re*.** The last note of this melody is A. When G is *do*, A is *re*, therefore this melody is in the **D dorian mode**.

Practice Question 20: Melodic Transcription without a Key signature

Melodic transcriptions will only be in a Major or melodic minor key therefore, determining the key of this melody for transcription will need only a few steps from the first tonality flowchart:

Melodic transcription without key signature

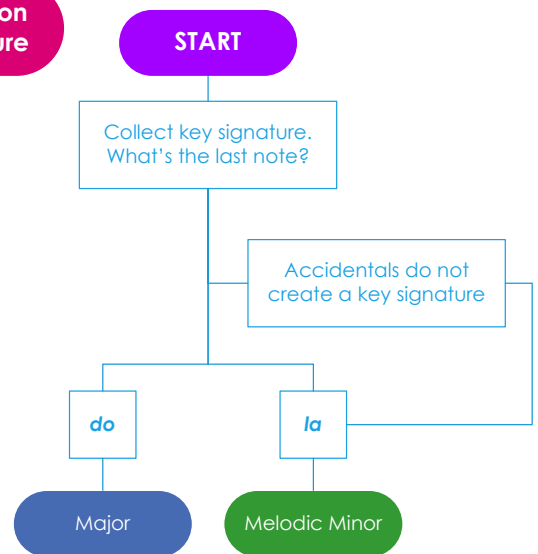

1. **Collect the key signature of this melody.**

What is the last note?

There are two flats: B \flat and E \flat in this melody, plus an F \sharp . The last note of the melody is G. Therefore:

2. **The accidentals do not create a logical key signature.**
This tells us the last note: G, must be *la* and B \flat is *do* and there would be a B \flat and E \flat in the key signature.
3. The E \flat (*fa*), E \natural (*fi*), F \sharp (*so*) and F \sharp (*si*) confirm the **G melodic minor** tonality of this melody.

Write the G melodic minor transcription scale on this staff with solfa and letter names beneath each note, **without a key signature:**

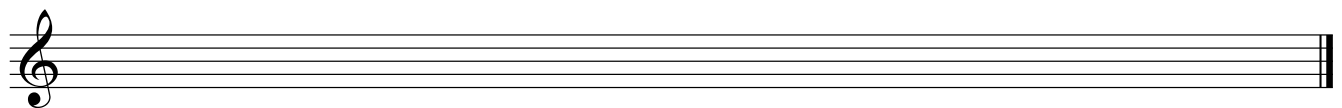

Follow the process from previous melodic transcriptions practice questions, remembering to write all sharps, flats and naturals required, due to the absence of a key signature, in your completed melody.

Melodic Transcription

S Worksheet 88

S15 Visual Key Recognition without a Key Signature 1

Tonality: _____

Worksheet 88 cont.

S15 Visual Key Recognition without a Key Signature 2

Tonality: _____

S15 Visual Key Recognition without a Key Signature 3

Tonality: _____

S15 Melodic Transcription 1

3/57

S15 Melodic Transcription 2

3/58

Section 15 - Chords



The Diminished 7th Chord

The **diminished 7th** chord (in root position) is made up of a root note and the notes a minor 3rd, a diminished 5th and a diminished 7th above the root note.

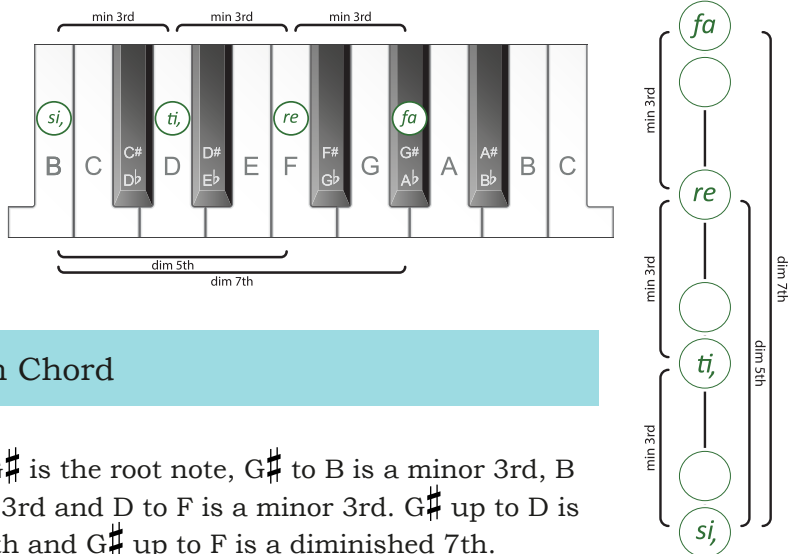

Intervals within a Diminished 7th Chord

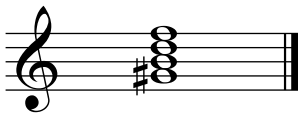

In this chord, G# is the root note, G# to B is a minor 3rd, B to D is a minor 3rd and D to F is a minor 3rd. G# up to D is a diminished 5th and G# up to F is a diminished 7th.

Labelling Diminished 7th Chords

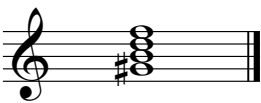

Chord Name: G# **diminished 7th** (it is the diminished 7th chord built on G#)

Roman numeral with Figures: Chord **vii^{o7}** in A harmonic minor (lower case with the small circle and a small 7 meaning diminished, the Roman numeral 7 showing the scale degree the chord is built on, with the small seven representing all the figures: $\frac{7}{3}$ indicating that the chord has a 7th, 5th and 3rd above the root note).

Diminished Chords - in Minor Keys

Diminished 7th chords can **only** be built on the 7th scale degree of a harmonic minor scale:

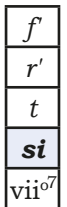
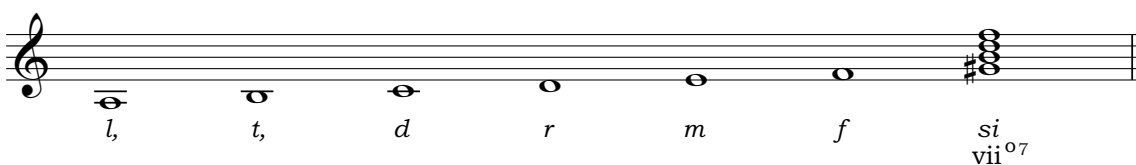

G# Diminished 7th Chord Melodically

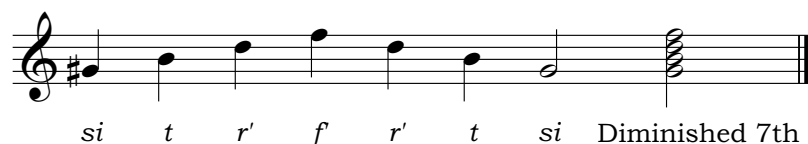

The structure of 3rds in a diminished 7th chord is **minor, minor, minor**



Intervals in the (G#) Diminished 7th Chord

si t r' f f r' t si diminished si t minor 3rd, 7th

t r' minor 3rd, r' f minor 3rd, si r' dim 5th, si f dim 7th.



Worksheet 89

S15 Chords 1 Write a diminished 7th chord **below** each of the given notes using accidentals where necessary.

S15 Chords 2 Write the diminished 7th chord built on the 7th scale degree in the harmonic minor keys with the following key signatures.

S15 Chords 3 In the keys indicated, write and name the specified chords.

leading note 7 Dominant Submediant leading note 7
 F# harmonic minor E harmonic minor F# Major E Major

S15 Chords 4 Name the harmonic minor key that each of the following diminished 7th chords belong to.

S15 Chords 5 Complete the following chart.

Chord	Lowest 3rd quality	Middle 3rd quality	Highest 3rd quality
Dominant 7			
Major 7			
minor 7			
half diminished			
diminished 7			

S15 Chords 6 Five chords will be played twice.

They will be Major, Augmented or Sus 4 triads or the Major 7th, half diminished or diminished 7th chords. Write the quality of each chord in the spaces provided.

1. 2. 3. 4. 5.

Section 15 - Chord Progressions

W Chord Charts for Transcriptions - including the Diminished 7th

The only place you will find a diatonic full diminished 7th chord is in an harmonic minor key. Here are all triads, the Dominant 7th, Major 7th, minor 7th, half diminished and diminished 7th chords in a harmonic minor key (A minor) on the staff and in transcription chord chart form:

l, *t*, *t*, *d*, *r*, *r*, *m*, *m*, *f*, *f*, *si*, *si*
i, *ii*^o, *ii*^ø, *III*⁺, *iv*, *iv*⁷, *V*, *V*⁷, *VI*, *VI*⁷, *vii*^o, *vii*^{ø7}

Minor Scale Chord Progression Transcription Chart Example (C minor)

C	D	E \flat	F	G	E \flat	B
<i>l</i> ,	<i>t</i> ,	<i>d</i>	<i>r</i>	<i>m</i>	<i>f</i>	<i>si</i>
<i>i</i>	<i>ii</i> ^o	<i>III</i> ⁺	<i>iv</i>	<i>V</i>	<i>VI</i>	<i>vii</i> ^o
	<i>ii</i> ^ø		<i>iv</i> ⁷	<i>V</i> ⁷	<i>VI</i> ⁷	<i>vii</i> ^{ø7}



Harmonic Minor Chord Chart - Practice (Triads and 7ths)

		<i>l</i>			<i>d'</i>		<i>r'</i>		<i>m'</i>		<i>f'</i>
<i>m</i>	<i>f</i>	<i>f</i>	<i>si</i>	<i>l</i>	<i>l</i>	<i>t</i>	<i>t</i>	<i>d'</i>	<i>d'</i>	<i>r'</i>	<i>r'</i>
<i>d</i>	<i>r</i>	<i>r</i>	<i>m</i>	<i>f</i>	<i>f</i>	<i>si</i>	<i>si</i>	<i>l</i>	<i>l</i>	<i>t</i>	<i>t</i>
<i>l</i> ,	<i>t</i> ,	<i>t</i> ,	<i>d</i>	<i>r</i>	<i>r</i>	<i>m</i>	<i>m</i>	<i>f</i>	<i>f</i>	<i>si</i>	<i>si</i>
<i>i</i>	<i>ii</i> ^o	<i>ii</i> ^ø	<i>III</i> ⁺	<i>iv</i>	<i>iv</i> ⁷	<i>V</i>	<i>V</i> ⁷	<i>VI</i>	<i>VI</i> ⁷	<i>vii</i> ^o	<i>vii</i> ^{ø7}

The Minor Major 7th Chord and the Augmented 7th Chord



A 7th chord built on the first degree of a harmonic minor scale is called a **Minor Major 7th chord**. It is rarely used except in the jazz idiom.



A 7th chord built on the third scale degree of a harmonic minor scale is called an **Augmented Major 7th** and is very rare in diatonic music.

Worksheet 90

S15 Recognition of a Chord Progression Instructions A chord progression will be played three times. Circle the correct option. The chord progression will be one of the following:

3/60

- a. $i - ii^{\circ} - iv - V^7 - i$ b. $i - iv^7 - vii^{\circ} - V - i$ c. $i - iv - III^+ - vii^{\circ} - V$
 d. $i - iv^7 - vii^{\circ} - V^7 - VI$ e. $i - iv^7 - i - vii^{\circ} - V$ f. $i - ii^{\circ} - V^7 - iv - V$

Write the transcription chord chart out first for all chord progression transcriptions.

Chord Progression Transcription Instructions Three chord progressions, using any root position triad or Dominant 7th, Major 7th, minor 7th, half diminished or diminished 7th chord found in a Major or harmonic minor scale, will be played several times. The first (tonic) chord is printed at the start of each progression. Identify the chords and the cadence you hear.

S15 Chord Progression 1

Cadence: _____

3/61

Harmonic Grid1. *i*

2.

3.

4.

5.

Bass note	D				
Quality	minor				

S15 Chord Progression 2

Cadence: _____

3/62

Harmonic Grid1. *d*

2.

3.

4.

5.

6.

Bass note	B \flat					
Quality	Major					

S15 Chord Progression 3

Cadence: _____

3/63

Harmonic Grid1. *i*

2.

3.

4.

5.

Bass note	B				
Quality	minor				

S15 Chord Progression 4

Cadence: _____

3/64

Harmonic Grid1. *d*

2.

3.

4.

5.

6.

Bass note						
Quality						

Section 15 - Revision & Practice Questions

Theory Revision

W

S15 Write the following rhythm in $\frac{6}{8}$ and $\frac{6}{4}$ correctly grouping the notes.

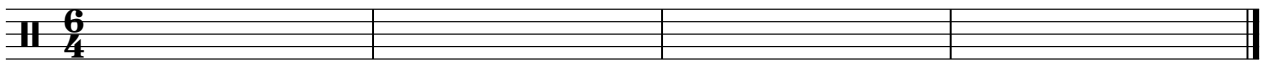
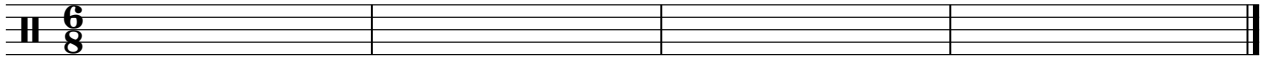

W

S15 Intervals Name the following intervals.

(Hint: write the letter names of these then work out the interval).

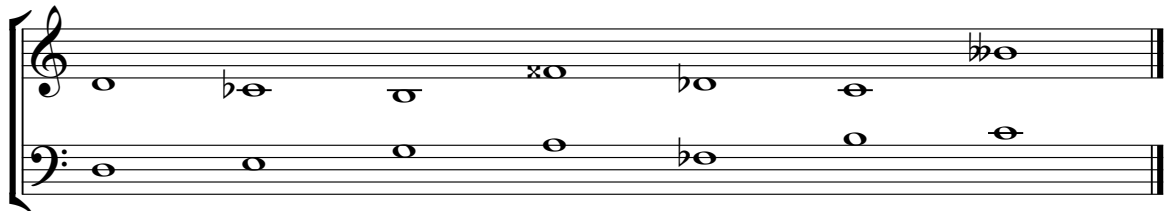

P

Musicianship Practice

PRACTICE ACTIVITIES

- Read rhythms in rhythm names, inner hearing all new rhythms, while conducting
- Compose rhythms, using new rhythms, then read in rhythm names
- Sing all known scales and modes in solfa with handsigns, changing at the top and bottom of each scale e.g. sing Major ascending, then from that top note sing natural minor descending, then from that bottom note sing the harmonic minor scale ascending etc
- Sing Major and melodic minor melodies in solfa with handsigns, inner hearing all notes belonging to the tonic triad
- Compose Major and melodic minor melodies then sing in solfa with handsigns
- Sing diminished 7th chords with intervals in solfa with handsigns
- Sing Major, minor, diminished, Augmented, Suspended 4th triads and Dominant 7th, Major 7th, minor 7th and half diminished chords in solfa with handsigns, from the same top note
- Sing "Major Chord Chart" in solfa with handsigns (page 182) inner hearing the second note of each chord
- Sing "Harmonic Minor Chord Chart" in solfa with handsigns (page 196) inner hearing the middle note of each chord

Section 16 - Rhythm

More Dotted Rhythms in Compound Time

are dotted rhythms lasting for one dotted crotchet beat.

Read Rhythmic Example 72 while clapping this ostinato:

The rhythm of the ostinato is written Rhythmic above the Example below. sounds the same as or

Rhythmic Example 72

tim - ka-ti-ka tim-ka-ti-ka etc

S Read Rhythmic Example 73 while clapping this ostinato:

The rhythm of the ostinato is written above the Rhythmic Example below. sounds the same as

Rhythmic Example 73

ti-ka-tik-tim tim-ka-ti-ka etc

Worksheet 91

S16 Rhythmic Transcription 1 (Watch out for the ties!)

3/65

S16 Rhythmic Transcription 2

3/66

Worksheet 91 cont.

S16 Rhythmic Transcription 3

3/67

S16 Rhythmic Transcription 4

Descant Recorder

Harmonica

Trombone

Bass Guitar

3/68

S16 Rhythmic Transcription 5

3/69

Worksheet 91 cont.

S16 Rhythmic Transcription 6

3/70

Percussion 

Piccolo 





S16 Rhythmic Transcription 7

3/71

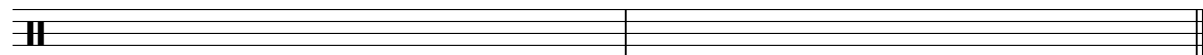

3



S16 Rhythmic Transcription 8

3/72



9



Section 16 - Scales



Other Modes



If we were to begin a mode on each of the seven white notes of the piano we would find the interval patterns for the five modes which have been discussed so far (Ionian beginning on C; Dorian beginning on D; Lydian beginning on F; Mixolydian beginning on G and Aeolian beginning on A). In addition there are two more modes: the **Phrygian mode** beginning on E and the **Locrian mode** beginning on B.



Phrygian Mode on E - Authentic

mi fa so la ti do' re' mi' re' do' ti la so fa mi
 E F G A B C D E D C B A G F E

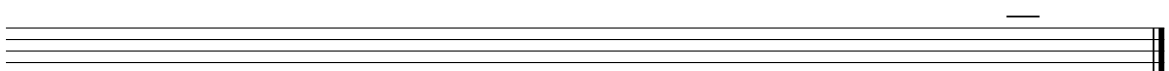
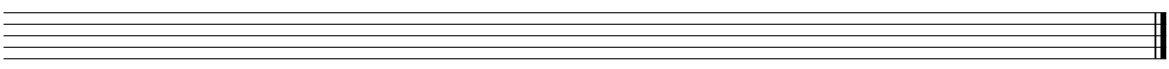
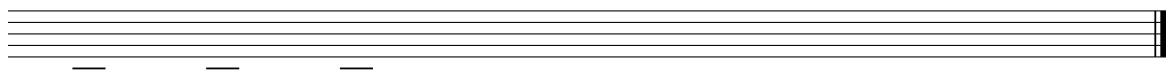
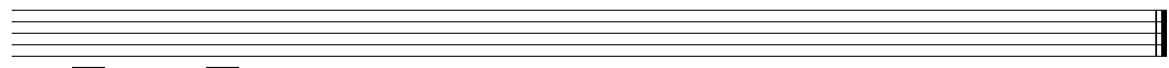
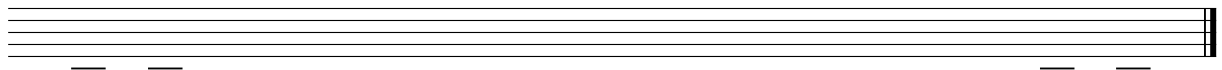

Worksheet 92 cont.

S16 Scales 3 Add accidentals to make the following notes a Lydian Mode. Show the semitone with slurs.

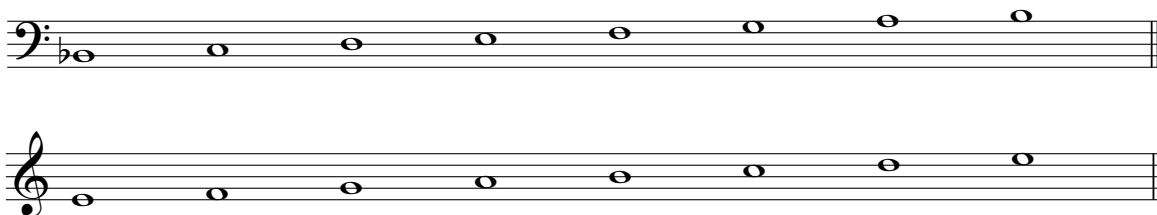

S16 Scales 4 Name the minor scales with the following key signatures.



S16 Scales 5 Write the key signatures for the given Major scales.

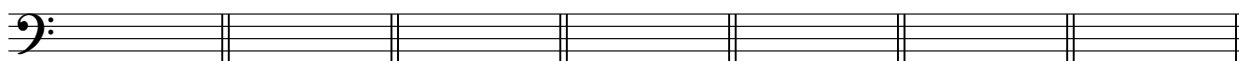

C Major F# Major A Major D \flat Major E \flat Major G Major C \flat Major

S16 Visual Key Recognition Circle the correct tonality of this melody from the choices given.



Scale form: melodic minor Major Pentatonic harmonic minor Lydian minor pentatonic

S16 Aural Tonality Recognition Instructions

Listen to the following melodies which will be played three times each.

Circle the correct tonality of each melody.

S16 Aural Tonality Recognition 1

3/73

Major minor pentatonic Lydian melodic minor dorian

S16 Aural Tonality Recognition 2

3/74

harmonic minor melodic minor Major pentatonic Mixolydian dorian

S16 Aural Tonality Recognition 3

3/75

natural minor Major pentatonic blues dorian Lydian

S16 Aural Tonality Recognition 4

3/76

Major melodic minor minor pentatonic blues Mixolydian

Section 16 - Intervals

Worksheet 93

S16 Intervals 1 Write an Augmented 5th above each of these notes.

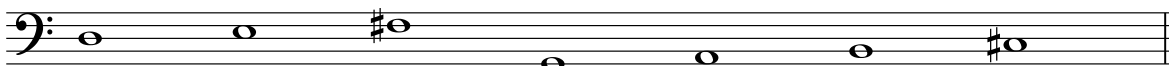

S16 Intervals 2 Write a tritone below each of these notes.

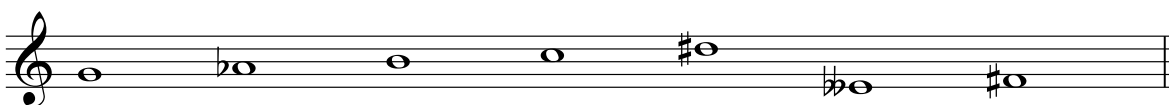

S16 Intervals 3 Identify the bracketed intervals in the following melodies. Write your answers (quality and number) beneath the brackets.



S16 Intervals 4 A melody will be played several times. The rhythm of this melody is printed below. Identify the first and last intervals (quality and number) and write your answers beneath the brackets. Circle the tonality of the melody below.



3/77

Scale form: harmonic minor Major minor Pentatonic dorian mode melodic minor

S16 Intervals 5 Name the following intervals.

(Hint: write the letter names of these then work out the interval).

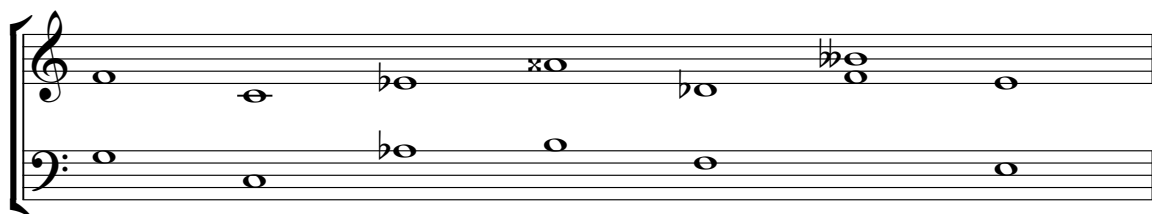

S16 Intervals 6 Six intervals will be played twice. Name the intervals you hear.

3/78

1. _____
2. _____
3. _____
4. _____
5. _____
6. _____

Section 16 - Melody

Use the flow chart on page 188 to work through the steps required to determine the tonality of the the "Irish Folksong" (without a key signature).

Irish Folksong

Irish Folksong

Authent c: *f l r d m f m l s f t l m r l t d etc*
 Altered Major: *d m l s t d t l r d fi m t l m fi s etc*

3

- What is the interval between the final note and the note a 3rd higher of this melody?** The last note of this melody is F. The note a 3rd higher than F is A, creating a Major 3rd. Therefore, consider the last note to be **do**.
- Are there any *fas* or *tis* in this melody?** Yes *ti* is the 7th scale degree (E) and is in the first bar of this melody, therefore, it cannot be based on a pentatonic scale.
- Begin again and determine *do* by collecting the key signature.** This melody has no sharps or flats in the key signature therefore, **C is *do***.
- Determine the solfa of the last note.** The last note of this melody is F. When C is *do*, F is ***fa*** which means that this melody is in the **F Lydian mode**.

Lydian Mode on F - Authentic

f s l t d' r' m' f m' r' d' t l s f
 F G A B C D E F E D C B A G F

Sing the "Lydian mode on F - Authentic" above then the "Irish Folksong" in solfa with handsigns using the authentic version.

As with the other modes studied so far, the Lydian mode can be sung using the altered version of solfa in which F is *do* and there is a raised *fa* which becomes *fi*.

Lydian Mode in F - Altered Major

d r m fi s l t d' t l s fi m r
 F G A B♯ C D E F E D C B♯ A G F

Sing the "Lydian mode in F - Altered Major" above, then the "Irish Folksong" in solfa with handsigns using the altered Major version.

fa

mi

re

do

ti

la

so

fa

do'

ti

la

so

fi

mi

re

do



Worksheet 94

S16 Melodic Transcription 1

3/79

Panpipes

Cor Anglais

f

Trombone

5 Panpipes

Cor Anglais

Trombone

S16 Melodic Transcription 2

3/80

Worksheet 94 cont.

S16 Melodic Transcription 3

3/81

4/4

4/4

4/4

S16 Melodic Transcription 4

3/82

2/4

2/4

2/4

Section 16 - Chords

Worksheet 95

S16 Chords 1 Write a Dominant triad for these harmonic minor keys. Do not use a key signature.

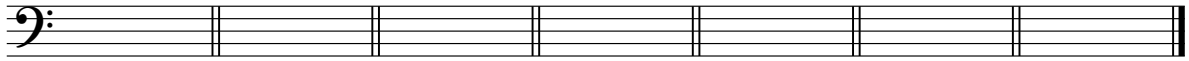

C minor D minor A minor C[#]minor G minor F minor B minor

S16 Chords 2 Write a half diminished chord above each of these notes.

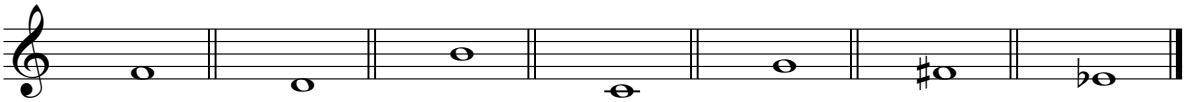

S16 Chords 3 In the tonic keys indicated, write and name the specified chords.

leading note half diminished C [#] Major	submediant Major 7th C harmonic minor	Dominant suspended 4th G ^b Major	leading note diminished 7th B harmonic minor
---	---	---	--

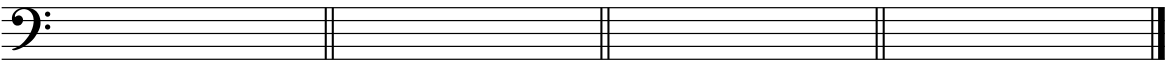

S16 Chords 4 Write the Augmented triad built on the 3rd scale degree in the harmonic minor keys with the following key signatures.



S16 Chords 5 Write a diminished 7th chord below each of these notes.



S7 Chords 6 Name the harmonic minor key that the following Dominant 7th chords belongs to.



Worksheet 95 cont.

S16 Chords 7 Fully identify each triad with letter name and quality.

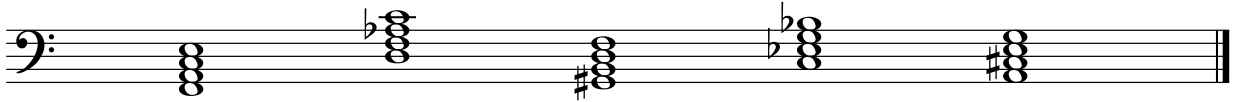

S16 Chords 8 Write the Roman numerals of the following triads found in the Major key with the given key signature.

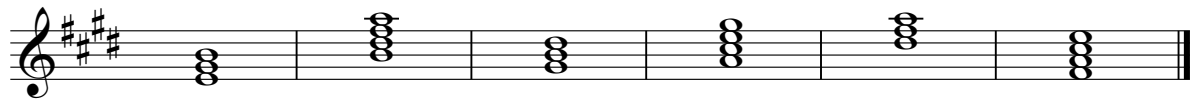

S16 Chords 9 Write the Roman numerals of the following triads found in the harmonic minor key with the given key signature.

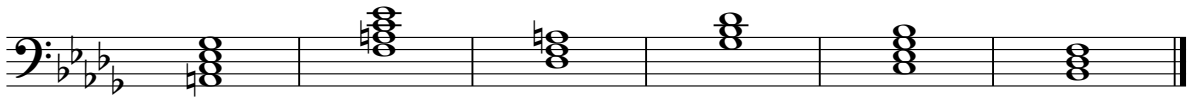

S16 Chords 10 Complete the following charts.

Triad	Lowest 3rd quality	Highest 2nd/3rd quality
Major		
minor		
diminished		
Augmented		
suspended 4th		

Chord	Lowest 3rd quality	Middle 3rd quality	Highest 3rd quality
Dominant 7			
Major 7			
minor 7			
half diminished			
diminished 7			

S16 Chords 11 Two sets of five chords will be played twice. They will be any triad or 7th chord. Write the quality of each chord in the spaces provided.

1. 2. 3. 4. 5.

3/83

1. 2. 3. 4. 5.

3/84

Section 16 - Chord Progressions



Worksheet 96

Write the transcription chord chart out first for all chord progression transcriptions.

S16 Chord Progression 1

Cadence: _____

3/85

Harmonic Grid 1. *d* 2. 3. 4. 5. 6.

Bass note	B \flat					
Quality	Major					

S16 Chord Progression 2

Cadence: _____

3/86

Harmonic Grid 1. *l* 2. 3. 4. 5.

Bass note	C				
Quality	minor				

S16 Chord Progression 3

Cadence: _____

3/87

Harmonic Grid 1. *d* 2. 3. 4. 5.

Bass note	C				
Quality	Major 7				

S15 Chord Progression 4

Cadence: _____

3/88

Harmonic Grid 1. *l* 2. 3. 4. 5. 6.

Bass note	G					
Quality	minor					

S15 Chord Progression 5

Cadence: _____

3/89

Harmonic Grid 1. *d* 2. 3. 4. 5. 6.

Bass note	A					
Quality	Major					

Worksheet 96 cont.

S16 Chord Progression 6

Cadence: _____

3/90

Harmonic Grid1. *l*

2.

3.

4.

5.

6.

Bass note	A					
Quality	minor					

S16 Chord Progression 7

Cadence: _____

3/91

Harmonic Grid1. *d*

2.

3.

4.

5.

6.

Bass note	G					
Quality	Major					

S16 Chord Progression 8

Cadence: _____

3/92

Harmonic Grid1. *l*

2.

3.

4.

5.

6.

Bass note	F#					
Quality	minor					

S16 Chord Progression 9

Cadence: _____

3/93

Harmonic Grid1. *d*

2.

3.

4.

5.

6.

Bass note	F					
Quality	Major					

S16 Chord Progression 10

Cadence: _____

3/94

Harmonic Grid1. *l*

2.

3.

4.

5.

6.

Bass note	E					
Quality	minor					

S16 Chord Progression 11

Cadence: _____

3/95

Harmonic Grid1. *d*

2.

3.

4.

5.

6.

Bass note	F					
Quality	Major					

Section 16 - Musicianship Practice

P

Musicianship Practice

PRACTICE ACTIVITIES
Rhythm
<ul style="list-style-type: none"> • Read rhythms in rhythm names while conducting, using the "Four Step Rhythm Practice Activity" on page 82 • Compose rhythms then read in rhythm names while conducting • Read rhythms in rhythm names while conducting inner hearing specific rhythms • Read rhythms in rhythm names while conducting inner hearing rhythms on specific beats
Scales
<p>Sing all known scales and modes in solfa with handsigns</p> <ul style="list-style-type: none"> • inner hearing specific notes e.g. tonics, notes in dominant triads, every second etc • using different rhythmic patterns • from same bottom/top note • changing at the top and bottom of each scale e.g. sing Major ascending, then from that top note sing natural minor descending, then from that bottom note sing the harmonic minor scale ascending etc
Intervals
<ul style="list-style-type: none"> • Sing consecutive intervals in all known scales and modes in solfa with handsigns • Sing all 3rds (4ths, 5ths etc) within known scales and modes, in solfa with handsigns • Sing intervals ascending and descending from a single note. • Practice intervals in abstract e.g. play a note and sing a chosen interval ascending or descending.
Melody
<ul style="list-style-type: none"> • Sing Major and melodic minor melodies in solfa with handsigns • Sing Major and melodic minor melodies in solfa with handsigns, inner hearing specific notes e.g. all notes belonging to the tonic triad etc • Compose Major and melodic minor melodies then sing in solfa with handsigns
Chords Continuously vary the order the chords are sung in
<ul style="list-style-type: none"> • Sing all known chords with intervals in solfa with handsigns, varying the order. • Sing all known chords in solfa with handsigns, from the same bottom/top note • Sing all known chords in solfa with handsigns, inner hearing specific notes • Sing all known chords in solfa with handsigns, changing at the top and bottom of each chord e.g. sing Major triad ascending, then from that top note sing minor triad descending, then from that bottom note sing the diminished triad ascending etc
Chord Progressions
<ul style="list-style-type: none"> • Sing all chords found in a Major scale in solfa with handsigns (page 182) • Sing all chords found in a harmonic minor scale in solfa with handsigns (page 196) • Sing all chords found in a Major and harmonic minor scales in a different order e.g. every 3rd chord: I iii V vii° ii IV vi etc

Appendices

Appendix 1

Solfa Names

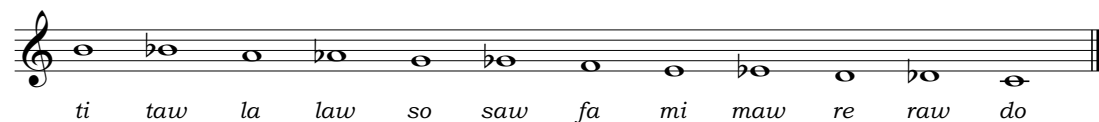
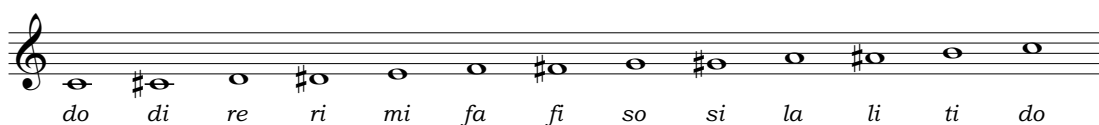

Letter Names



Handsigns

Solfa Name	Handsign	Common Alterations	Handsign
<i>ti</i>		<i>taw</i>	
<i>la</i>			
<i>so</i>		<i>si</i>	
<i>fa</i>		<i>fi</i>	
<i>mi</i>		<i>maw</i>	
<i>re</i>			
<i>do</i>			

Appendix 2

Major and Relative Minor Key Signatures - Treble Clef

Sharp Keys

(C Major/
A minor:



G Major/
E minor:



D Major/
B minor:



A Major/
F# minor:



E Major/
C# minor:



B Major/
G# minor:



F# Major/
D# minor:

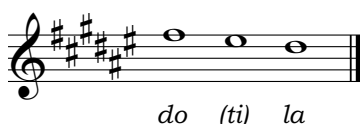

C# Major/
A# minor:

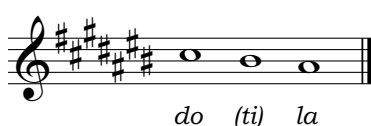

Flat Keys

(C Major/
A minor:



F Major/
D minor:



Bb Major/
G minor:



Eb Major/
C minor:

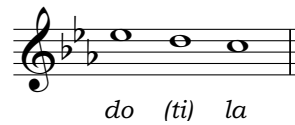

Ab Major/
F minor:



Dbb Major/
Bb minor:



Gb Major/
Eb minor:



Cb Major/
Ab minor:

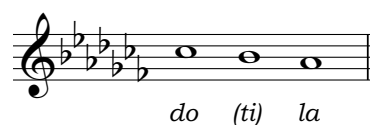

Appendix 2 cont.

Major and Relative Minor Key Signatures - Bass Clef

Sharp Keys

(C Major/
A minor:



do (ti) la

G Major/
E minor:

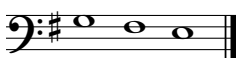

do (ti) la

D Major/
B minor:

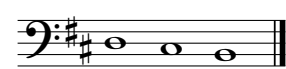

do (ti) la

A Major/
F# minor:



do (ti) la

E Major/
C# minor:

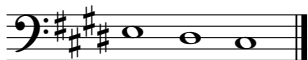

do (ti) la

B Major/
G# minor:



do (ti) la

F# Major/
D# minor:



do (ti) la

C# Major/
A# minor:

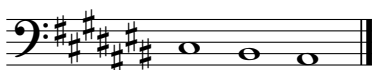

do (ti) la

Flat Keys

(C Major/
A minor:

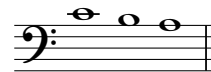

do (ti) la

F Major/
D minor:

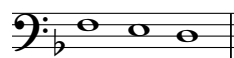

do (ti) la

Bb Major/
G minor:



do (ti) la

Eb Major/
C minor:

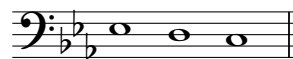

do (ti) la

Ab Major/
F minor:



do (ti) la

Db Major/
Bb minor:



do (ti) la

Gb Major/
Eb minor:



do (ti) la

Cb Major/
Ab minor:

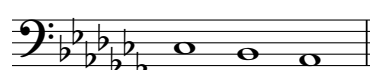

do (ti) la

Appendix 3

Tonality Flow Chart - with Key Signatures

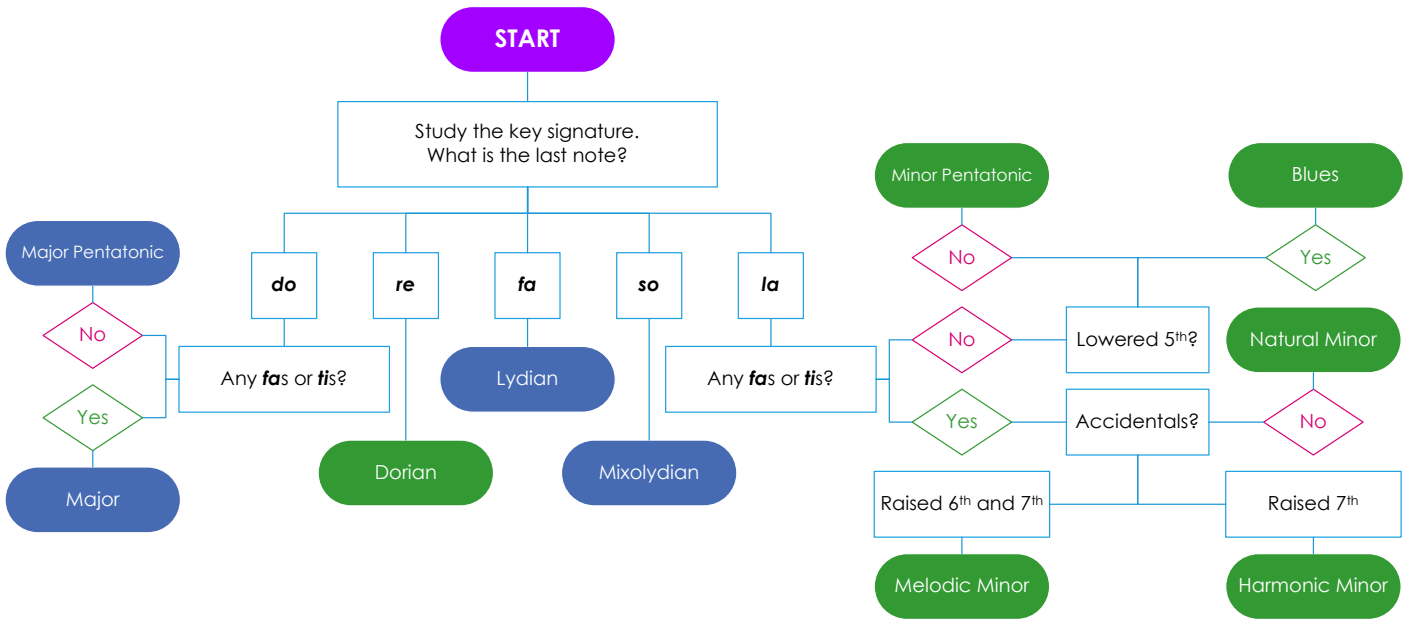

Tonality Flow Chart - without Key Signatures

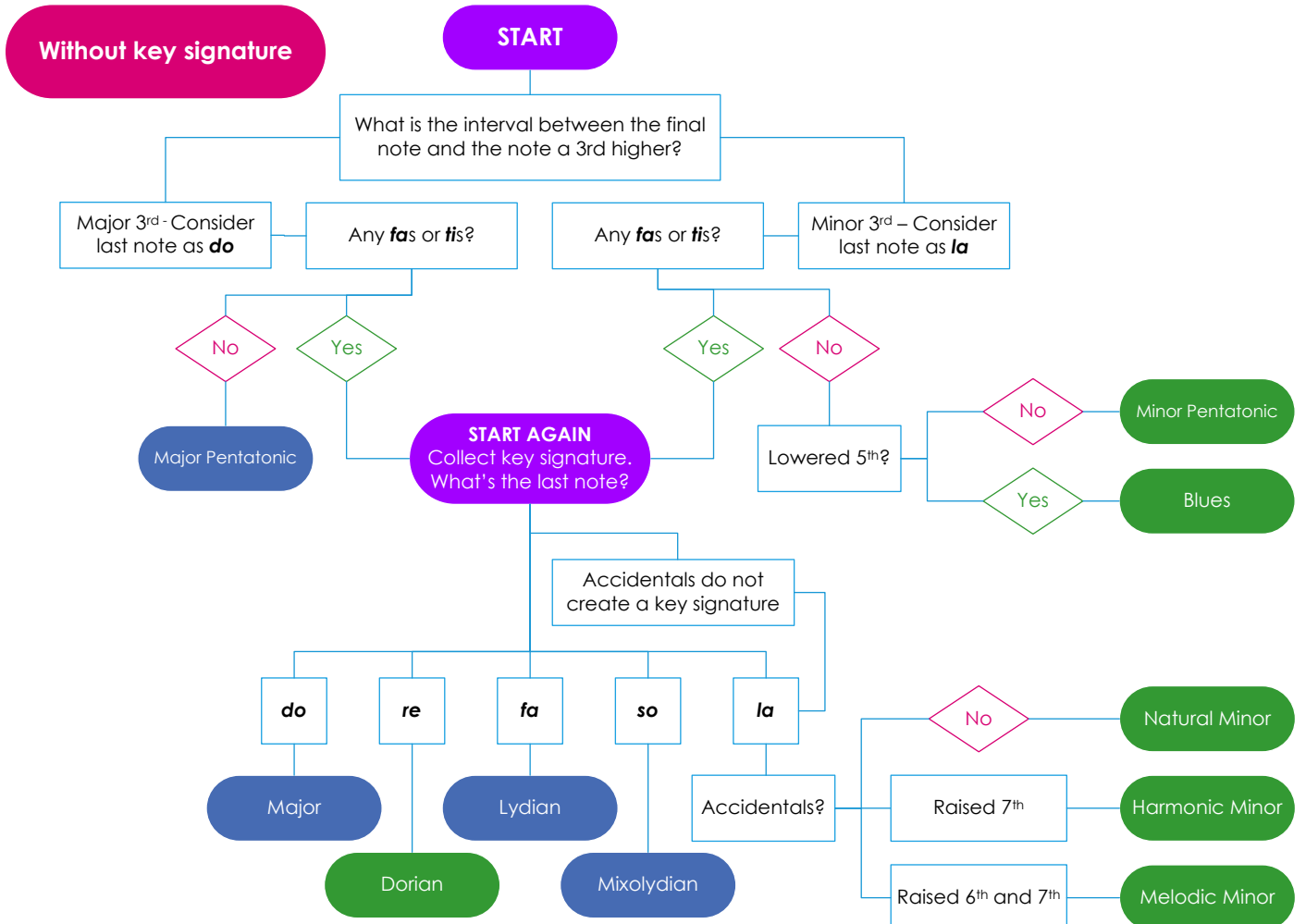

do'
ti
la
so
fa
mi
re
do

la
so
fa
mi
re
do
ti,
la,

la
si
fa
mi
re
do
ti,
la,

la
si
fa
mi
re
do
ti,
la,

la
so
fa
mi
re
do
ti,
la,

do'

la
so

mi
re
do

la
so

mi
re
do

la,

la
so

mi
re
do

la,

so
fa
mi
re
do
ti,
la,
so,

re'
do'
ti
la
so
fa
mi
re

fa
mi
re
do
ti,
la,
so,
fa,

Tone Ladders - Triads

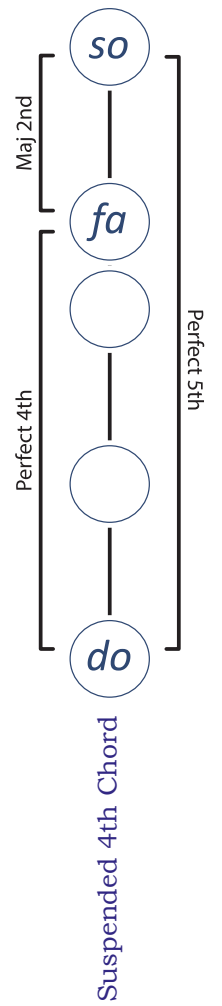
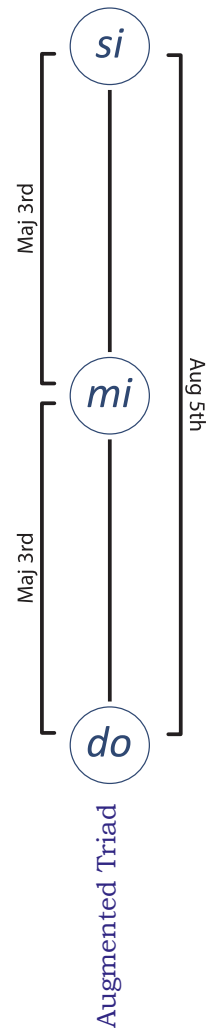
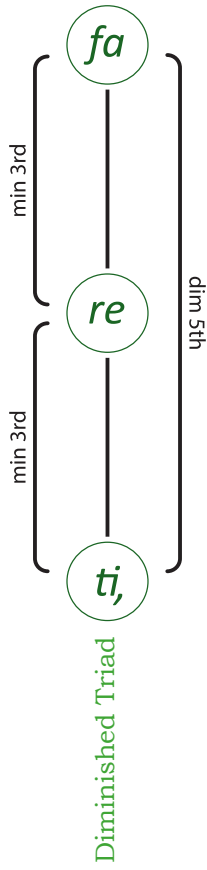
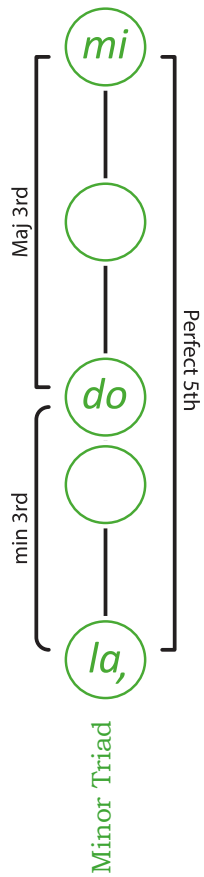
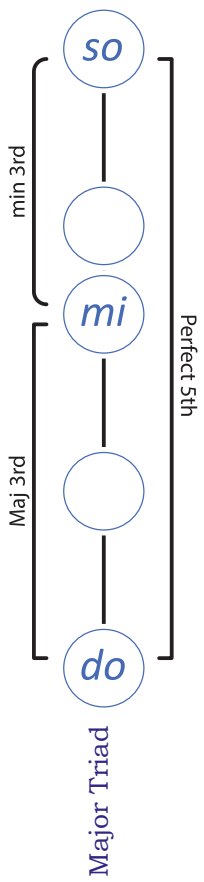

Tone Ladders - 7th Chords

