

**eBookplus**  
www.jacplus.com.au

Dan O'KEEFE | Graeme LOFTS  
Murray ANDERSON | Peter PENTLAND  
Ross PHILLIPS

# PHYSICS

VCE UNITS 3 AND 4

# 2

**+** studyon

**jacaranda**  
A Wiley Brand



# PHYSICS

VCE UNITS 3 AND 4

# 2



# PHYSICS

VCE UNITS 3 AND 4

# 2

Dan O'KEEFFE  
Graeme LOFTS  
Murray ANDERSON  
Peter PENTLAND  
Ross PHILLIPS  
Pam ROBERTSON  
Michelle LIVETT  
Jon PEARCE

First published 2017 by  
John Wiley & Sons Australia, Ltd  
42 McDougall Street, Milton, Qld 4064

Typeset in 10.5/12 pt Utopia Std

© John Wiley & Sons Australia, Ltd 2017

The moral rights of the authors have been asserted.

National Library of Australia  
Cataloguing-in-publication data

---

Creator:	O’Keeffe, Dan, 1947– author.
Title:	Physics 2: VCE units 3 & 4 / Dan O’Keeffe, Graeme Lofts, Peter Nelson, Peter Pentland, Ross Phillips.
ISBN:	978 0 7303 2884 1 (set) 978 0 7303 2885 8 (paperback) 978 0 7303 2888 9 (eBook) 978 0 7303 3128 5 (studyON)
Notes:	Includes index.
Target Audience:	For secondary school age.
Subjects:	Physics — Textbooks. Victorian Certificate of Education examination — Study guides.
Other Creators/ Contributors:	Lofts, Graeme, author. Nelson, Peter, author. Pentland, Peter, 1955– author. Phillips, Ross, author.
Dewey Number:	530

---

#### **Reproduction and communication for educational purposes**

The Australian *Copyright Act 1968* (the Act) allows a maximum of one chapter or 10% of the pages of this work, whichever is the greater, to be reproduced and/or communicated by any educational institution for its educational purposes provided that the educational institution (or the body that administers it) has given a remuneration notice to Copyright Agency Limited (CAL).

#### **Reproduction and communication for other purposes**

Except as permitted under the Act (such as a fair dealing for the purposes of study, research, criticism or review), no part of this book may be reproduced, stored in a retrieval system, communicated or transmitted in any form or by any means without prior written permission. All inquiries should be made to the publisher.

#### **Trademarks**

Jacaranda, the JacPLUS logo, the learnON, assessON and studyON logos, Wiley and the Wiley logo, and any related trade dress are trademarks or registered trademarks of John Wiley & Sons Inc. and/or its affiliates in the United States, Australia and in other countries, and may not be used without written permission. All other trademarks are the property of their respective owners.

*Cover image:* Shutterstock/Samet Guler

Typeset in India by Aptara

Illustrated by various artists, Aptara and Wiley Composition Services

Printed in Singapore by  
Markono Print Media Pte Ltd

10 9 8 7 6 5 4 3 2

All activities have been written with the safety of both teacher and student in mind. Some, however, involve physical activity or the use of equipment or tools. All due care should be taken when performing such activities. Neither the publisher nor the authors can accept responsibility for any injury that may be sustained when completing activities described in this textbook.

# Contents

About eBookPLUS and studyON ix

About this book x

Acknowledgements xii

## UNIT 3

### AREA OF STUDY 1

#### CHAPTER 1

### Forces in action 2

#### Describing motion 3

The language of motion 3

Acceleration 4

#### Graphical analysis of motion 5

Position–time graphs 5

Velocity–time graphs 6

Acceleration–time graphs 6

#### Algebraic analysis of motion 8

#### Newton's laws of motion 10

Changing motion 10

Newton's First Law of Motion 10

Newton's Second Law of Motion 11

Newton's Third Law of Motion 11

#### Feeling lighter — feeling heavier 12

Accelerating upwards 12

Accelerating downwards 12

#### Applying Newton's Second Law of Motion 13

On the level 15

Inclined to move 16

#### Projectile motion 18

Falling down 18

Moving and falling 19

What goes up must come down 22

Shooting at an angle 25

Projectile motion calculations 27

The real world — including air resistance 27

#### Uniform circular motion 28

Getting nowhere fast 28

Instantaneous velocity 28

Changing velocities and accelerations 29

Calculating accelerations and forces 31

Examples of forces that produce centripetal acceleration 33

Friction 34

Inside circular motion 36

#### Non-uniform circular motion 38

Amusement park physics 39

#### Chapter review 41

#### CHAPTER 2

### Collisions and other interactions 47

Impulse and momentum in a collision 48

Impulse from a graph 49

Momentum and impulse 50

Conservation of momentum 50

Modelling a collision 51

Work in energy transfers and transformations 54

Getting down to work 55

Gravitational potential energy 56

Strain potential energy and springs 58

Hooke's Law springs to mind 59

Elastic and inelastic collisions 61

A tale of two collisions 62

What's the difference? 62

Energy transformations in collisions 63

#### Chapter review 67

#### CHAPTER 3

### Special relativity 72

#### What is relativity? 73

There is no rest 73

The principle of relativity 74

Examples of Galilean relativity 76

Frames of reference 78

#### Electromagnetism brings new challenges 80

The Michelson–Morley experiment 82

Einstein's two postulates of special relativity 82

Broadening our horizons 83

The speed of light is constant 85

Space–time diagrams 86

#### Time dilation 87

Time dilation and modern technology 90

Length contraction 90  
A note on seeing relativistic effects 95  
    The journey of muons 95  
The most famous equation:  $E = mc^2$  97  
    Kinetic energy in special relativity 101  
    Mass conversion in the Sun 101  
**Chapter review 104**

## AREA OF STUDY 1

### CHAPTER 4

## Gravitation 107

Explaining the solar system 108  
    Evidence of elliptical orbits 108  
    Kepler's Second Law 109  
    Kepler's Third Law 109  
    Newton's Law of Universal Gravitation 110  
    Gravitational fields 114  
Astronauts and satellites in orbit 122  
    Geostationary satellites 122  
    'Floating' in a spacecraft 124  
**Chapter review 126**

### CHAPTER 5

## Electric fields 129

The long road to Coulomb's Law 130  
Electric fields 132  
    Drawing an electric field 132  
    Calculating the value of an electric field 133  
    Dipole fields 134  
    Graphing the electric field 135  
    Changes in potential energy and kinetic energy in an electric field 136  
    Uniform electric fields 136  
Linking the concepts together 140  
**Chapter review 142**

### CHAPTER 6

## Magnetic fields 145

Early ideas about magnetism 146  
    Magnetic fields 148  
Magnetic effect of a current 149  
    The right-hand-grip rule 150  
Differences between magnetic fields 152  
Explaining magnetism 152  
Comparing gravitational, electric and magnetic fields 153  
Magnetic force on an electric current 154  
    Left-hand rule 155  
    Right-hand-slap rule 155  
Magnetic propulsion 156  
Meters 156  
    DC motors 156  
Magnetic force on charges 158

Crossed electric and magnetic fields 161  
Overview 161  
**Chapter review 162**

## AREA OF STUDY 2

### CHAPTER 7

## Generating electricity 166

Making electricity 167  
    Generating voltage with a magnetic field 167  
    Generating a current 168  
    The source of a current's electrical energy 169  
Faraday's discovery of electromagnetic induction 170  
Magnetic flux 171  
Induced EMF 173  
    Rotating a loop 175  
    Using Lenz's Law 175  
    Using magnetic force on the charges in the wire 176  
    Peak, RMS and peak-to-peak voltages 177  
Producing a greater EMF 178  
**Chapter review 180**

### CHAPTER 8

## Transmission of power 183

Electric power 184  
Transformers 185  
    How does a transformer work? 186  
Power distribution and transmission line losses 189  
    Using Ohm's Law wisely 193  
**Chapter review 195**

## UNIT 4

## AREA OF STUDY 1

### CHAPTER 9

## Mechanical waves 198

Light and its properties 199  
    Sources of light 199  
    Speed of light 200  
    Shadows 201  
    Ray model 202  
    Plane mirror reflection 202  
    Regular and diffuse reflection 203  
    What is colour? 204  
Waves — energy transfer without matter transfer 204  
Properties of waves 205  
Interference of waves 207  
    Superposition 207  
    Reflection of waves 208  
    Standing waves 209  
    Interference of waves in two dimensions 211



- Interference with sound 213
- Colour effects of interference 215
- Diffraction 216**
  - Diffraction of water waves 216
  - Directional spread of different frequencies 217
- The Doppler effect 218**
- Resonance 221**
- Chapter review 222**

## CHAPTER 10

### Light as a wave 226

- Bending of light 227**
- Snell's Law 227**
- Limitations of the ray model 229**
  - Speed of light in glass 232
- Total internal reflection and critical angle 233**
  - Mirages 234
  - Optical fibres 236
  - Dispersion: producing colour from white light 237
- Rainbows 239**
- Young's experiment 239**
  - Interpreting Young's experiment 241
  - Spacing of bands in an interference pattern 243
- Other interference experiments 245**
  - Newton's rings 245
  - Fresnel's biprism 245
  - Lloyd's mirror 246
- Diffraction of light 246**
  - Diffraction and optical instruments 248
  - Linking diffraction and interference 249
- Light as an electromagnetic wave 249**
- Polarisation 252**
- Chapter review 255**

## AREA OF STUDY 2

### CHAPTER 11

### The photoelectric effect 260

- Physics before the observation of the photoelectric effect 261**
- A mysterious radiation 263**
  - Some preliminaries — measuring the energy of light and the energy of electrons 265
  - Measuring the energy of photoelectrons 267
- The photoelectric effect 269**
  - The experiment 270
  - The particle model view of a light bulb 273
  - A wave model view of a light bulb 274
- The particle model and the photoelectric effect 275**
  - An energy perspective 276
  - Explaining Lenard's experimental observations 277

- What's wrong with the wave model? 281**
- Great photoelectric effect results 282**
- A photon model for the photoelectric effect 285**
- Chapter review 286**

## CHAPTER 12

### Matter — particles and waves 289

- The particle model of matter unhinged 290**
- The discovery of electrons 291**
- Emission spectra — atoms emit photons 293**
- Absorption spectra — atoms absorb photons 298**
  - Comparing emission and absorption spectra 298
- Making light 303**
  - Accelerating charged particles 303
  - Thermal radiation 303
  - Incandescent light sources 304
  - Fluorescent light sources 304
  - Light-emitting diodes 306
- Synchrotron radiation 306**
  - Characteristics of synchrotron radiation 306
- The wave behaviour of electrons 308**
  - Matter waves show themselves 310
  - Electrons through foils 312
- Electrons, atoms and standing waves 315**
  - Louis de Broglie's picture 315
- Waves or particles? 316**
  - Photons have wave properties too 316
- Heisenberg's uncertainty principle 318**
- Why classical laws of physics are unable to model motion at very small scales 322**
- Chapter review 323**

## AREA OF STUDY 3

### CHAPTER 13

### Practical investigations 327

- What is the benefit to you? 328**
- What is involved? 328**
  - How does this investigation differ from the Unit 2 investigation? 328
- Selecting a topic 329**
  - Turning the topic into a good question 330
- Submitting a research proposal 330**
  - Keep a log 330
- Variables 332**
- Selecting your measuring instruments 332**
  - Making the most of a measurement 335
  - Repeated measurements 336
- Finding patterns 338**
  - Drawing a line of best fit 338
  - Using Microsoft Excel 339
- Other aspects of scientific measurement 339**

**Handling difficulties 340**

**Safety 340**

**Presenting your work for assessment 340**

Presenting your work as a digital poster 341

Advice on assembling a poster 341

**Topics 342**

Brainstorming variables 344

**Chapter review 345**

**Appendix 1: Skill checks 347**

**Appendix 2: Periodic table of the elements 360**

**Appendix 3: Some useful astronomical data 362**

**Appendix 4: Useful formulae 363**

**Glossary 366**

**Answers to numerical questions 370**

**Index 376**

# About eBookPLUS and studyON

Access your online Jacaranda resources anywhere, anytime, from any device in three easy steps:

- STEP 1** Go to [www.jacplus.com.au](http://www.jacplus.com.au) and create a user account.
- STEP 2** Enter your registration code.
- STEP 3** Instant access!

## eBookplus







## studyon



**eBookPLUS** is an electronic version of the textbook, together with a targeted range of supporting multimedia resources.

#### eBookPLUS features:





-  **eBook** — the entire textbook in electronic format
-  **Digital documents** designed for easy customisation and editing
-  **Interactivities** to reinforce and enhance students' learning
-  **eLessons** — engaging video clips and supporting material
-  **Weblinks** to relevant support material on the internet

**eGuidePLUS** features assessment and curriculum material to support teachers.



**studyON** is an interactive and highly visual online study, revision and exam practice tool designed to help students and teachers maximise exam results.

#### studyON features:

-  **Concept summary screens** provide concise explanations of key concepts, with relevant examples.
-  **Access 1000+ past VCAA questions** or custom-authored practice questions at a concept, topic or entire course level, and receive immediate feedback.
-  **Sit past VCAA exams** (Units 3 & 4) or **topic tests** (Units 1 & 2) in exam-like situations.
-  **Video animations and interactivities** demonstrate concepts to provide a deep understanding (Units 3 & 4 only).
-  **All results and performance in practice and sit questions** are tracked to a concept level to pinpoint strengths and weaknesses.



**NEED HELP?** Go to [www.jacplus.com.au](http://www.jacplus.com.au) and select the Help link.

- Visit the JacarandaPLUS Support Centre at <http://jacplus.desk.com> to access a range of step-by-step user guides, ask questions or search for information.
- **Contact** John Wiley & Sons Australia, Ltd.  
**Email:** [support@jacplus.com.au](mailto:support@jacplus.com.au)  
**Phone:** 1800 JAC PLUS (1800 522 7587)

#### Minimum requirements

JacarandaPLUS requires you to use a supported internet browser and version, otherwise you will not be able to access your resources or view all features and upgrades. Please view the complete list of JacPLUS minimum system requirements at <http://jacplus.desk.com>.

# About this book

Physics 2 VCE Units 3 and 4 has the following features.

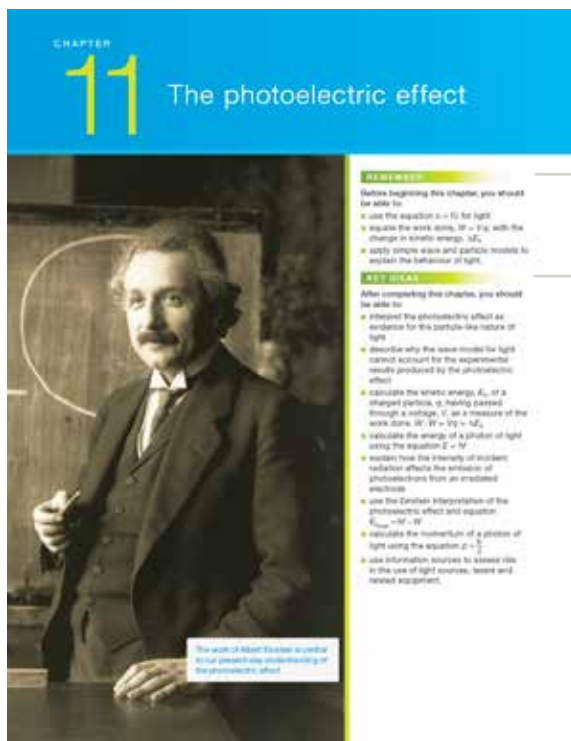

A list of skills and knowledge, which draws on students' prior learning

An overview of the Key knowledge and outcomes addressed in this chapter

Sample problems with worked solutions to enhance understanding. These are often followed by revision questions.

Definitions and formulae to summarise key knowledge

**Sample problem 11.2**

(a) What is the energy of each photon emitted by a source of green light having a wavelength of 513 nm?

(b) How many photons per second are emitted by a light source emitting a power of 0.3 W as 513 nm light? (This power is similar to the power emitted by a 40 W fluorescent tube as the wavelength range 513 to 515 nm.)

**Solution:** (a) The photon energy can be found as follows:

$$E_{\text{photon}} = \frac{hc}{\lambda}$$

$$= \frac{6.63 \times 10^{-34} \text{ J s} \times 3.00 \times 10^8 \text{ m s}^{-1}}{513 \times 10^{-9} \text{ m}}$$

$$= 3.86 \times 10^{-19} \text{ J}$$

(b) The power emitted by the globe is:

$$\text{power} = \frac{\text{energy emitted}}{\text{time interval}}$$

$$= \frac{E}{\Delta t}$$

$$= N E_{\text{photon}}$$

where  $N$  is the number of photons emitted in the time interval  $\Delta t$ .

So

$$N = \frac{\text{power} \times \Delta t}{E_{\text{photon}}}$$

$$= \frac{0.3 \text{ W} \times 1 \text{ s}}{3.86 \times 10^{-19} \text{ J}}$$

$$= 8 \times 10^{17} \text{ s}^{-1}$$

Since each photon carries a tiny amount of energy, huge numbers of photons are emitted from quite ordinary light sources in each second.

**Revision question 11.3**

A radio station has a 1000 W transmitter and transmits electromagnetic radiation with a frequency 104.9 MHz. Calculate the number of photons emitted per second by the transmission.

**A mysterious radiation**

A mysterious sort of radiation discovered in 1895 was given a mysterious-sounding name: X-rays. Wilhelm Röntgen was studying the behaviour of cathode rays. These rays travel from the negative electrode, the cathode, to the positive electrode, the anode, of an evacuated tube. These rays could travel the length of the evacuated tube but could not penetrate the end of the tube. Röntgen had completely covered the cathode ray tube with black cardboard and turned the lights off so he could check that the coating was opaque. He was amazed to see a small glow, just like fluorescent paint,

An X-ray is a form of electromagnetic radiation with a frequency above that of ultraviolet radiation.

X-radiation is a stream of electrons emitted between a cathode (negative electrode) and an anode (positive electrode) in an evacuated tube.

Röntgen discovered the light emitted from materials as a result of exposure to ionising radiation.

eLessons, interactivities, weblinks and eModelling Excel spreadsheets that enhance understanding and bring concepts to life

References to studyON concept summaries encapsulate key knowledge and provide questions with answers and worked solutions to reinforce learning.

studyON topic tests have additional multiple choice, short answer and extended response questions that are different to the end of chapter review questions.

Chapter summaries give a detailed overview of key knowledge.

### Worked Example 1

**Problem** The photoelectric effect

(a) A particle model and (b) a wave model of light intensity

The kinetic energy of each photoelectron is given by:

$$E_k = E_{\text{photon}} - E_{\text{threshold}} = hf - hf_0$$

The maximum kinetic energy of photoelectrons,  $E_{k \text{ max}}$ , is given by:

$$E_{k \text{ max}} = E_{\text{photon}} - W = hf - hf_0$$

where  $W$  is the work function.

**An energy perspective**

An energy picture of the effect can also be useful. Note that the vertical axis in the figure below is *not* the depth of the electrons in the material, but the electron energy. Electrons in the metal have a range of energies, depending on how strongly they are bound to the metal. Electrons having higher energies are more loosely held by the material and need to receive less energy to escape than electrons at lower energy.

Four identical photons deliver their energy to four electrons. (a) Electron escapes with maximum  $E_k = hf - W$ . (b) Photon energy is just enough for electron to escape, but electron  $E_k$  is zero. (c) Electron escapes with  $E_k = hf - E_{\text{binding}}$ . (d)  $E_k = \text{maximum } E_k$ . (e) Photon energy is insufficient to excite electron to escape.

As a matter of fact and Physics in focus panels to highlight applications of physics, show relevance and add interest

### PHYSICS IN FOCUS

#### Solar cells

Telephone installations in remote locations extract energy from the sun using technology based on the transfer of photon energy to electrons. They use solar cells to convert solar energy to electrical energy. This is achieved by photons transferring their energy to electrons so that they are able to conduct electricity.

Solar cells use metal using semiconductors like silicon. In semiconductors only about  $1 \times 10^8$  of the electrons have sufficient energy to be conducted electrons. In metals the other 99.9999999 are about  $1 \times 10^{28}$ . Conduction electrons are not bound to any particular atom in the crystal. They can travel through the material where a potential difference is applied across it, producing an electric current.

The real part of a solar cell is a sandwich of two different types of impure semiconductor material, called *n* type and *p* type. The sandwich layers are only tens of microns thick. Electrons drift from the *n* type material, containing electrons that are not attached to any particular atom, to the *p* type material, where there are gaps for electrons in the bonding structure. This creates an electric field in the layer of material very close to the boundary between the two types, with the electrons in stable positions at the bonding structure of the semiconductor material.

When the electric circuit containing this cell is in the dark, the electric field has an effect, but in the way that solar photons stream onto the cell.

If a photon has sufficient energy, then it can knock an electron out of its orbit in the material, exciting it to become a conduction electron and leaving a hole behind in the bonding structure. If this occurs within the region where there is an electric field, the electron hole assigns the electron through the cell, and through the circuit, contributing to the electric current.

The efficiency of a solar cell is limited by many factors. If the surface is too shiny, photons are reflected, so the surface isn't usually roughened. The cell's spectrum itself limits how well the cell can make use of the photons. In silicon, a voltage of 1.1 V is needed to transmit a typical electron into a conduction electron. This corresponds to a wavelength of  $1.1 \times 10^{-7} \text{ m}$ . Not only the light and part of the spectrum, photons  $1.1 \text{ V}$  pass straight through a single silicon cell; a small to convert trapped electrons into ions.

How solar cells convert energy of photons of this radiation into electrical energy

Only some of the photons of sunlight are of use to a silicon solar cell.

### Chapter review

#### Summary

- The equation  $v = f\lambda$  describes the speed of a wave in terms of its frequency,  $f$ , and wavelength,  $\lambda$ .
- The photoelectric effect is the emission of electrons from materials, usually metals, by the action of light.
- The photoelectric effect is best explained by considering light as consisting of a stream of particles called photons. Each photon has an energy,  $E$ , that is dependent on only the frequency of the light,  $f$ , according to the equation  $E = hf$ . This is the Einstein interpretation of the photoelectric effect.
- The stopping voltage is a suit of energy,  $1 \text{ eV} = 1.6 \times 10^{-19} \text{ J}$ .
- When a photon hits an electron in a metal, it will transfer either all or none of its energy to an electron. This occurs within a time interval of typically  $10^{-15} \text{ s}$  of a beam of light striking a surface.
- The maximum kinetic energy of emitted electrons,  $E_{k \text{ max}}$ , is given by the equation  $E_{k \text{ max}} = hf - W$ , where  $f$  is the frequency of the light and  $W$  is the work function of the material.
- The maximum kinetic energy of the electrons emitted because of the photoelectric effect can be determined by measuring the stopping voltage,  $V_s$ .  $E_{k \text{ max}} = eV_s$ .
- The intensity of light has no effect on the stopping voltage but only affects the current proportion to the size of the photocurrent. A more model for light cannot account for this, but a particle model of light can.
- A graph of the maximum kinetic energy of emitted electrons plotted against frequency gives a straight line. The gradient of the graph is Planck's constant,  $h$ . The *y*-intercept is the work function,  $W$ , and the *x*-intercept is the threshold frequency,  $f_0$ .
- The photoelectric effect is strong evidence for light consisting of a stream of particles.

#### Phenomena have associated, $n$ , given by the equation $n = \frac{c}{\lambda}$ , where $\lambda$ is the wavelength of the photon.

#### Questions

##### Electromagnetic radiation

- The light from a red light-emitting diode (LED) has a frequency of  $4.39 \times 10^{14} \text{ Hz}$ .  
(a) What is the wavelength of this light?  
(b) What is the period of this light?
- We can detect light when our eye receives as little as  $2 \times 10^{-17} \text{ J}$ . How many photons of green light is that?
- Use the gaps in table 11.2 with the missing wavelength, frequency, photon energy and photon momentum values for the five different sources of electromagnetic radiation.
- A red laser emitting 600 nm light and a blue laser emitting 400 nm light could the same power. Compare their rate of emitting photons.

##### The photoelectric effect

- The diagram below shows a cathode several electrons that have been ejected from the cathode by light, and an anode. The electrons leaving the cathode surface have been identified with their kinetic energy and their initial velocity vector. The anode is 1 cm from the cathode.

(a) What is the speed of the electrons which have a kinetic energy of 0.5 eV?  
Copy the diagram and show in the path you would expect such electrons to take for each of the potential differences,  $V$ , in parts (b) to (d) on the next page.

Review questions reinforce understanding and are divided by headings to make content easy to identify.

# Acknowledgements

The authors and publisher would like to thank the following copyright holders, organisations and individuals for their assistance and for permission to reproduce copyright material in this book.

## Images

• AAP Newswire: **73** (lower right)/Alan Porritt/AAP Image • Alamy Australia Pty Ltd: **73** (upper left)/World History Archive; **124**/Marvin Dembinsky Photo Associates; **236**/Phil Crosby; **294** (b)/© sciencephotos; **294** (d)/© Phil Degginger; **305** (mercury spectrum)/© sciencephotos • ALS: **307** (top) • ANSTO: **307** (bottom left)/© Australian Nuclear Science and Technology Organisation. www.ansto.gov.au • AusNet: **183** • Australian Synchrotron: **100** • Bausch & Lomb USA: **305** • Bhavesh Chauhan: **334** (bottom) • Creative Commons: **260**/https://en.wikipedia.org/wiki/Albert\_Einstein#/media/File:Einstein\_1921\_by\_F\_Schmutzer\_-\_restoration.jpg; **291**/https://commons.wikimedia.org/wiki/File:JJ\_Thomson\_Nobel.jpg?uselang=en-gb • Dan O’Keeffe: **327** • european space agency: **125** (top)/http://www.esa.int/spaceinimages/Images/2009/10/Frank\_De\_Winne\_exercises\_on\_the\_COLBERT\_treadmill • Fundamental Photographs: **259**/© Richard Megna Fundamental Photographs, NYC • Fundamental Photos: **259** (left) • Getty Images Australia/ Science Photo Library: **265**, **294** (c), **305** (sodium and neon spectra) • © John Wiley & Sons Australia: **227**, **233**/Photos by Ron Ryan • Molecular Expressions: **306**/© National High magnetic Field Laboratory • NASA-JPL: **125** (bottom) • Newspix: **76**/Photo by News Ltd • NSRRC: **308**/© NSRRC. www.srrc.gov.tw • ©Philips Lighting Holding B.V.: **301** (b) • © Photodisc, Inc.: **28**, **216** • Picture Source, The: **204** (a)/flowers in white light - Ref No. A203.1, **204** (b)/flowers in red light - Ref No. A203.3, **204** (c)/flowers in blue light - Ref No. A203.5 • Public Domain: **161**/NASA; **245**, **248**; **249** (top)/Wikimedia Commons; **335** (top)/Paul Slichter • Science Photo Library: **241** (top) • Shutterstock.com: **1**/AWISBY; **2**/jabiru; **16**/Bahadir Yeniceri; **25**/murartart; **28**/lisal1983; **30**/JASPERIMAGE; **33** (upper left)/jenny; **33** (lower)/Olga Besnard; **34** (upper)/Naturesports; **34** (lower)/Rena Schild; **47**/Dmitry Kalinovsky; **50** (upper)/CHEN WS; **50** (lower)/endeavor; **58**/StockPhotosArt; **64**/Evgeny Murtola; **66**/Vereshchagin Dmitry; **72**/imagIN.gr photography; **73** (lower left)/Ben Jeayes; **74**/Georgios Kollidas; **90**/dennizn; **102**/Triff; **107**/3Dsculptor; **129**/James BO Insogna; **145**/Klaus Kreckler; **151**/dvande; **157**/mosufoto; **160** (a)/Fineart1; **160** (d)/Dragon Images; **166**/Teun van den Dries; **178**/Arogant; **188**/Ilia Torlin; **197**/Kostyuk Alexander; **199**/Allexandar; **202**/fStop Images GmbH; **215**/wi6995; **226**/david muscroft; **230**/Mellimage; **235**/Artesia Wells; **237**/AlexLMX; **253**/martinnovacek.cz; **284**/leungchopan; **289**/SmallAtomWorks; **294** (a)/Yiorgos GR; **301** (a)/photosync; **302**/Aumm graphixphoto; **333** (upper)/glenda; **333** (lower)/Sergio Ponomarev; **334** (upper left)/Science Photo Library; **334** (upper right)/ShiningBlack; **335** (lower)/litchima; **336**/Oliver Lenz Fotodesign • Springer: **253** (right) • University of Cambridge: **247** (left)

## Text

• **Appendix 4**/Formula reproduced from the 2015 VCE Physics Written Examination Formula Sheet, © VCAA, used with permission. The VCAA does not endorse this Wiley publication and makes no warranties regarding the correctness or accuracy of its content. Current VCE content can be accessed directly at www.vcaa.vic.edu.au.

Every effort has been made to trace the ownership of copyright material. Information that will enable the publisher to rectify any error or omission in subsequent reprints will be welcome. In such cases, please contact the Permissions Section of John Wiley & Sons Australia, Ltd.

# UNIT 3

## AREA OF STUDY 3

**CHAPTER 1** Forces in action

**CHAPTER 2** Collisions and other interactions

**CHAPTER 3** Special relativity

## AREA OF STUDY 1

**CHAPTER 4** Gravitation

**CHAPTER 5** Electric fields

**CHAPTER 6** Magnetic fields

## AREA OF STUDY 2

**CHAPTER 7** Generating electricity

**CHAPTER 8** Transmission of power



## CHAPTER

# 1

# Forces in action

### REMEMBER

Before beginning this chapter, you should be able to:

- describe and analyse uniform straight line motion graphically and algebraically
- explain how changes in motion are caused by the action of forces
- model forces as external pushes and pulls acting through the centre of mass of an object
- use Newton's three laws of motion to explain movement
- apply the vector model of forces, including addition and components of forces.

### KEY IDEAS

After completing this chapter, you should be able to:

- apply algebraic and graphical methods to the analysis of changes in motion
- apply Newton's three laws of motion to situations in which two or more coplanar forces act in a straight line and two dimensions
- analyse the motion of projectiles near Earth's surface
- analyse uniform circular motion in a horizontal plane
- apply Newton's second law to non-uniform circular motion in a vertical plane.

A photograph of a roller coaster car filled with passengers, inverted and moving through a large white vertical loop. The background is a clear blue sky.

Whether you are driving a car, riding a bike or riding a roller-coaster, your motion is controlled by the forces acting on the vehicle.



# Describing motion

In order to explain the motion of objects, it is important to be able to measure and describe it clearly. The language used to describe motion must therefore be precise and unambiguous.

## The language of motion

**Distance** is a measure of the length of the path taken when an object changes position. It is a scalar quantity.

**Displacement** is a measure of the change in position of an object. It is a vector quantity.

A **scalar quantity** has magnitude (size) but not direction.

A **vector quantity** has direction as well as magnitude (size).

**Speed** is a measure of the time rate at which an object moves over a distance.

**Velocity** is a measure of the time rate of displacement, or the time rate of changing position. It is a vector quantity.

**Instantaneous speed** is the speed at a particular instant of time.

**Instantaneous velocity** is the velocity at a particular instant of time.

**Distance** is a measure of the length of the path taken during the change in position of an object. Distance is a scalar quantity. It does not specify a direction.

**Displacement** is a measure of the change in position of an object. In order to fully describe a displacement, a direction must be specified as well as a magnitude. Displacement is therefore a vector quantity.

### REMEMBER THIS

The physical quantities used to describe and explain motion fall into two distinct groups — scalar quantities and vector quantities.

**Scalar quantities** are those that can be described without specifying a direction. Mass, energy, time and temperature are all examples of scalar quantities.

**Vector quantities** are those that can only be fully described by specifying a direction as well as a magnitude. Force, displacement, velocity and acceleration are all examples of vector quantities.

**Speed** is a measure of the rate at which an object moves over a distance. Because distance is a scalar quantity, speed is also a scalar quantity. The average speed of an object can be calculated by dividing the distance travelled by the time taken:

$$\text{average speed} = \frac{\text{distance travelled}}{\text{time interval}}$$

**Velocity** is a measure of the rate of displacement of an object. Because displacement (change in position) is a vector quantity, velocity is also a vector quantity. The velocity has the same direction as the displacement. The symbol  $v$  is used to denote velocity. (The symbol  $v$  is often used to represent speed as well.)

The average velocity of an object,  $v_{\text{av}}$  during a time interval can be expressed as:

$$v_{\text{av}} = \frac{\Delta x}{\Delta t}$$

where

$\Delta x$  represents the displacement

$\Delta t$  represents the time interval.

Neither the average speed nor the average velocity provide information about movement at any particular instant of time. The speed at any particular instant of time is called the **instantaneous speed**. The velocity at any particular instant of time is called, not surprisingly, the **instantaneous velocity**. It is only if an object moves with a constant velocity during a time interval that its instantaneous velocity throughout the interval is the same as its average velocity.

**Acceleration** is the rate of change of velocity. It is a vector quantity.

## Acceleration

The rate at which an object changes its velocity is called its **acceleration**. Because velocity is a vector quantity, it follows that acceleration is also a vector quantity. The average acceleration of an object,  $\mathbf{a}_{av}$ , can be expressed as:

$$\mathbf{a}_{av} = \frac{\Delta \mathbf{v}}{\Delta t}$$

where

$\Delta \mathbf{v}$  = the change in velocity ( $\mathbf{v} - \mathbf{u}$ ) during the time interval  $\Delta t$ .

The direction of the average acceleration is the same as the direction of the change in velocity. The instantaneous acceleration of an object is its acceleration at a particular instant of time.

A non-zero acceleration is not always caused by a change in speed. The vector nature of acceleration means that it can have a non-zero value when either or both of the magnitude and direction of the velocity change. Sample problem 1.1 illustrates this.

### Sample problem 1.1

Determine the average acceleration of each of the following objects.

- A car starting from rest reaches a velocity of  $60 \text{ km h}^{-1}$  due north in 5.0 s.
- A car travelling due west at a speed of  $15 \text{ m s}^{-1}$  turns due north at a speed of  $20 \text{ m s}^{-1}$ . The change occurs in a time interval of 2.5 s.
- A cyclist riding due north at  $8.0 \text{ m s}^{-1}$  turns right to ride due east without changing speed in a time interval of 4.0 s.

**Solution:** (a) The change in velocity of the car is  $60 \text{ km h}^{-1}$  north. In order to determine the acceleration in SI units, the velocity should be expressed in  $\text{m s}^{-1}$ .

$$60 \text{ km h}^{-1} = 16.7 \text{ m s}^{-1} \quad (\text{divide by 3.6 to convert from km h}^{-1} \text{ to m s}^{-1})$$

Thus,

$$\begin{aligned} \mathbf{a}_{av} &= \frac{\Delta \mathbf{v}}{\Delta t} \\ &= \frac{16.7 \text{ m s}^{-1} \text{ north}}{5.0 \text{ s}} \\ &= 3.3 \text{ m s}^{-2} \text{ north.} \end{aligned}$$

(b) The change in velocity must first be found by subtracting vectors because  $\Delta \mathbf{v} = \mathbf{v} - \mathbf{u}$ .

The magnitude of the change in velocity can be found by using Pythagoras's theorem or by trigonometry.

$$\begin{aligned} \Delta v &= \sqrt{(20 \text{ m s}^{-1})^2 + (15 \text{ m s}^{-1})^2} \\ &= 25 \text{ m s}^{-1} \end{aligned}$$

The direction can be found by calculating the value of the angle  $\theta$ .

$$\begin{aligned} \tan \theta &= \frac{15}{20} \\ &= 0.75 \\ \Rightarrow \theta &= 37^\circ \end{aligned}$$

The direction of the change in velocity is therefore N37°E.

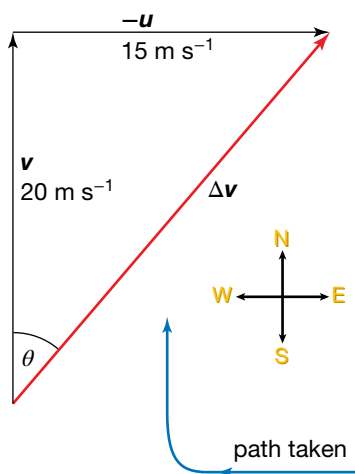

The average acceleration of the car is given by:

$$\begin{aligned} \mathbf{a}_{av} &= \frac{\Delta \mathbf{v}}{\Delta t} \\ &= \frac{25 \text{ m s}^{-1} \text{ N}37^\circ\text{E}}{2.5 \text{ s}} \\ &= 10 \text{ m s}^{-2} \text{ N}37^\circ\text{E}. \end{aligned}$$

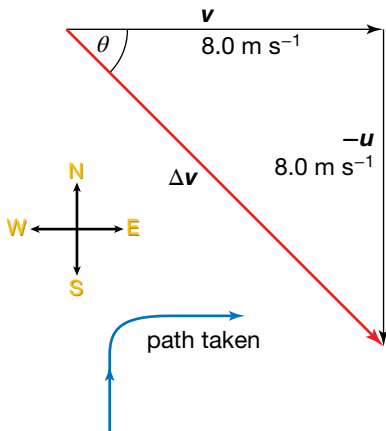

(c) The magnitude of the change in velocity can be found by applying Pythagoras's theorem to the vector diagram.

$$\begin{aligned} \Delta v &= \sqrt{(8.0 \text{ m s}^{-1})^2 + (8.0 \text{ m s}^{-1})^2} \\ &= 11.3 \text{ m s}^{-1} \end{aligned}$$

The triangle formed by the vector diagram shown is a right-angled isosceles triangle. The angle  $\theta$  is therefore  $45^\circ$  and the direction of the change in velocity is south-east.

The average acceleration of the cyclist is given by:

$$\begin{aligned} \mathbf{a}_{av} &= \frac{\Delta \mathbf{v}}{\Delta t} \\ &= \frac{11.3 \text{ m s}^{-1} \text{ south-east}}{4.0 \text{ s}} \\ &= 2.8 \text{ m s}^{-2} \text{ south-east}. \end{aligned}$$

### Revision question 1.1

Determine the average acceleration of:

- a rocket launched from rest that reaches a velocity of  $15 \text{ m s}^{-1}$  during the first  $5.0 \text{ s}$  after lift-off
- a roller-coaster cart travelling due north at  $20 \text{ m s}^{-1}$  that turns left during an interval of  $4.0 \text{ s}$  without changing speed
- a rally car travelling west at  $100 \text{ km h}^{-1}$  that turns left and slows to a speed of  $80 \text{ km h}^{-1}$  south. The turn takes  $5.0 \text{ s}$  to complete. Provide your answer in  $\text{m s}^{-2}$ .

## Graphical analysis of motion

A description of motion in terms of displacement, average velocity and average acceleration is not complete. These quantities provide a 'summary' of motion, but do not provide detailed information. By describing the motion of an object in graphical form, it is possible to estimate its displacement, velocity or acceleration at any instant during a chosen time interval.

### Position–time graphs

A graph of position versus time provides information about the displacement and velocity at any instant of time during the interval described by the graph. If the graph is a straight line or smooth curve, it is also possible to estimate the displacement and velocity outside the time interval described by the graph.

The velocity of an object at an instant of time can be obtained from a position–time graph by determining the gradient of the line or curve at the point representing that instant. This method is a direct consequence of the fact that velocity is a measure of the rate of change in position. If the graph is a

**eLesson**

Motion with constant acceleration  
eles-0030

smooth curve, the gradient at an instant of time is the same as the gradient of the tangent to the curve at that instant.

Similarly, the speed of an object at an instant of time can be obtained by determining the gradient of a graph of the object's distance from a reference point versus time.

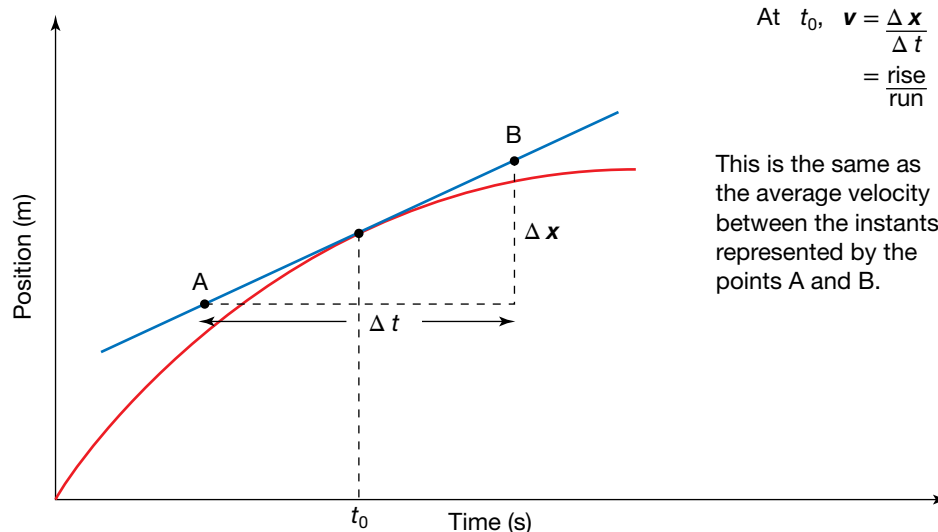

The instantaneous velocity  $v$  of an object is equal to the gradient of the position-time graph. If the graph is a smooth curve, the gradient of the tangent must be determined.

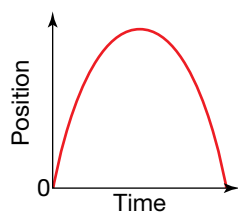

**gradient**

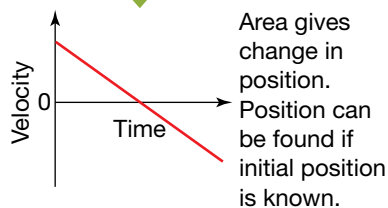

**gradient**

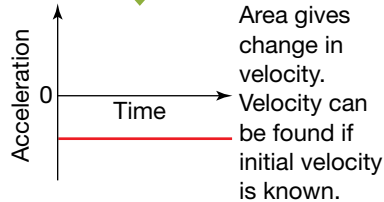

The position-time, velocity-time and acceleration-time graphs for an object thrown vertically into the air (air resistance is assumed to be negligible). As long as one graph is given, the other two can be deduced. However, some extra information is needed in some cases.

### Velocity-time graphs

A graph of velocity versus time provides information about the velocity and acceleration at any instant of time during the interval described by the graph. It also provides information about the displacement between any two instants.

The instantaneous acceleration of an object at an instant of time can be obtained from a velocity-time graph, by determining the gradient of the line or curve at the point representing that instant. This method is a direct consequence of the fact that acceleration is defined as the rate of change of velocity. If the graph is a smooth curve, the gradient at an instant of time is the same as the gradient of the tangent to the curve at that instant.

The displacement of an object during a time interval can be obtained by determining the area under the velocity-time graph representing that time interval. The actual position of an object at any instant during the time interval can be found only if the starting position is known.

Similarly, the distance travelled by an object during a time interval can be obtained by determining the corresponding area under the speed-versus-time graph for the object.

### Acceleration-time graphs

A graph of acceleration versus time provides information about the acceleration at any instant of time during the time interval described by the graph. It also provides information about the change in velocity between any two instants.

The change in velocity of an object during a time interval can be obtained by determining the area under the acceleration-time graph representing that time interval. The actual velocity of the object can be found at any instant during the time interval only if the initial velocity is known.

### Sample problem 1.2

The velocity–time graph below describes the motion of a car as it travels due south through an intersection. The car was stationary for 6.0 s while the traffic lights were red.

- What was the displacement of the car during the interval in which it was slowing down?
- What was the average acceleration of the car during the first 4.0 s after the lights turned green?
- Determine the average velocity of the car during the interval described by the graph.

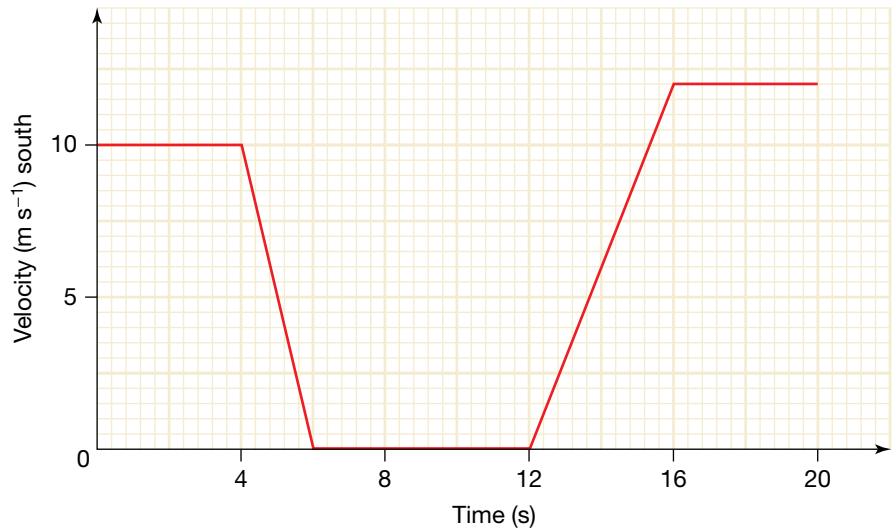

- Solution:** (a) The displacement of the car while it was slowing down is given by the area under the graph describing the time interval between 4.0 s and 6.0 s.

$$\begin{aligned}\text{area} &= \frac{1}{2} \times 2.0 \text{ s} \times 10 \text{ m s}^{-1} \text{ south} \\ &= 10 \text{ m south}\end{aligned}$$

Note that the units need to be considered when calculating the area. In this case, the area has a direction as well.

- (b) The average acceleration is given by the gradient of the graph describing the first 4.0 s after the lights turned green; that is, the time interval between 12 and 16 s.

$$\begin{aligned}\mathbf{a} &= \frac{\text{rise}}{\text{run}} \\ &= \frac{12 \text{ m s}^{-1} \text{ south}}{4.0 \text{ s}} \\ &= 3.0 \text{ m s}^{-2} \text{ south}\end{aligned}$$

- (c) The average velocity is determined by the formula:

$$\mathbf{v}_{\text{av}} = \frac{\Delta \mathbf{s}}{\Delta t}.$$

The displacement during the whole time interval described by the graph is given by the total area under the graph.

$$\begin{aligned}
 \text{area} &= 4.0 \text{ s} \times 10 \text{ m s}^{-1} + \left(\frac{1}{2} \times 20 \text{ s} \times 10 \text{ m s}^{-1}\right) + \left(\frac{1}{2} \times 4.0 \text{ s} \times 12 \text{ m s}^{-1}\right) \\
 &\quad + (4.0 \text{ s} \times 12 \text{ m s}^{-1} \text{ south}) \\
 &= 40 \text{ m} + 10 \text{ m} + 24 \text{ m} + 48 \text{ m south} \\
 &= 122 \text{ m south} \\
 \Rightarrow v_{\text{av}} &= \frac{122 \text{ m south}}{20 \text{ s}} \\
 &= 6.1 \text{ m s}^{-1} \text{ south}
 \end{aligned}$$

### Revision question 1.2

Use the velocity–time graph in sample problem 1.2 to answer the following questions.

- What was the acceleration of the car while it had a positive southerly acceleration?
- What was the acceleration of the car during the 2.0 s before it came to a stop at the traffic lights?
- What was the average velocity of the car during the 6.0 s before it stopped at the traffic lights?

### study on

Unit 3

AOS 3

Topic 1

Concept 5

**Equations of constant acceleration motion**

Summary screen and practice questions

## Algebraic analysis of motion

The motion of an object moving in a straight line with a constant acceleration can be described by a number of formulae. The formulae are expressed in terms of:

- initial velocity,  $u$
- final velocity,  $v$
- acceleration,  $a$
- time interval,  $t$
- displacement,  $s$ .

### REMEMBER THIS

Each of these four formulae allows you to determine an unknown characteristic of straight line motion with a constant acceleration, as long as you know three other characteristics.

$$v = u + at \quad s = \frac{1}{2}(u + v)t \quad s = ut + \frac{1}{2}at^2 \quad v^2 = u^2 + 2as$$

The first two formulae above can be derived from the definitions of velocity and acceleration. The other two can be derived by combining the first two. Because the formulae describe motion along a straight line, vector notation is not necessary. The displacement, velocity and acceleration can be expressed as positive or negative quantities.

### Sample problem 1.3

Amy rides a toboggan down a steep snow-covered slope. starting from rest, she reaches a speed of  $12 \text{ m s}^{-1}$  as she passes her brother, who is standing

19 m further down the slope from her starting position. Assume that Amy's acceleration is constant.

- Determine Amy's acceleration.
- How long did she take to reach her brother?
- How far had Amy travelled when she reached an instantaneous velocity equal to her average velocity?
- At what instant was Amy travelling at an instantaneous velocity equal to her average velocity?

**Solution:** (a)  $a = ?$ ,  $u = 0$ ,  $v = 12 \text{ m s}^{-1}$ ,  $s = 19 \text{ m}$

The appropriate formula here is  $v^2 = u^2 + 2as$ , because it includes the three known quantities and the unknown quantity  $a$ .

$$v^2 = u^2 + 2as$$

$$\Rightarrow (12 \text{ m s}^{-1})^2 = 0 + 2 \times a \times 19 \text{ m}$$

$$\Rightarrow 38 \text{ m} \times a = 144 \text{ m}^2 \text{ s}^{-2}$$

$$\Rightarrow a = 3.8 \text{ m s}^{-2} \text{ down the slope}$$

(b)  $t = ?$ ,  $u = 0$ ,  $v = 12 \text{ m s}^{-1}$ ,  $s = 19 \text{ m}$

(Note that it is better to use the data given rather than data calculated in the previous part of the question. That way, rounding off or errors in an earlier part of the question will not affect this answer.)

The appropriate formula here is  $s = \frac{1}{2}(u + v)t$ .

$$\Rightarrow 19 \text{ m} = \frac{1}{2}(0 + 12 \text{ m s}^{-1})t$$

$$\Rightarrow 19 \text{ m} = 6.0 \text{ m s}^{-1} \times t$$

$$\Rightarrow t = \frac{19 \text{ m}}{6.0 \text{ m s}^{-1}}$$

$$= 3.2 \text{ s}$$

(c) The magnitude of the average velocity during a period of constant acceleration is given by:

$$v_{\text{av}} = \frac{u + v}{2}$$

$$= \frac{0 + 12 \text{ m s}^{-1}}{2}$$

$$= 6.0 \text{ m s}^{-1}.$$

The distance travelled when Amy reaches an instantaneous velocity of this magnitude can now be calculated.

$s = ?$ ,  $u = 0$ ,  $v = 6.0 \text{ m s}^{-1}$ ,  $a = 3.8 \text{ m s}^{-2}$  (Here we have no choice but to use calculated data rather than given data.)

The appropriate formula here is  $v^2 = u^2 + 2as$ .

$$\Rightarrow (6.0 \text{ m s}^{-1})^2 = 0 + 2 \times 3.8 \text{ m s}^{-2} \times s$$

$$\Rightarrow 36 \text{ m}^2 \text{ s}^{-2} = 7.6 \text{ m s}^{-2} \times s$$

$$\Rightarrow s = \frac{36 \text{ m}^2 \text{ s}^{-2}}{7.6 \text{ m s}^{-2}}$$

$$\Rightarrow = 4.7 \text{ m}$$

Note that this is well short of the halfway mark in terms of distance.

(d)  $t = ?$ ,  $u = 0$ ,  $v = 6.0 \text{ s}$ ,  $a = 3.8 \text{ m s}^{-2}$

The appropriate formula here is  $v = u + at$ .

$$\Rightarrow 6.0 \text{ m s}^{-1} = 0 + 3.8 \text{ m s}^{-2} \times t$$

$$\Rightarrow t = \frac{6.0 \text{ m s}^{-1}}{3.8 \text{ m s}^{-2}}$$

$$= 1.6 \text{ s} \quad (\text{rounded off from } 1.58)$$

This is the midpoint of the entire time interval. In fact, during any motion in which the acceleration is constant, the instantaneous velocity halfway (in time) through the interval is equal to the average velocity during the interval.

### Revision question 1.3

A car initially travelling at a speed of  $20 \text{ m s}^{-1}$  on a straight road accelerates at a constant rate for 16 s over a distance of 400 m.

- (a) Calculate the final speed of the car.
- (b) Determine the car's acceleration without using your answer to part (a).
- (c) What is the average speed of the car?
- (d) What is the instantaneous speed of the car after:
  - (i) 2.0 s
  - (ii) 8.0 s?

## Newton's laws of motion

Sir Isaac Newton's three laws of motion, first published in 1687, explain changes in the motion of objects in terms of the forces acting on them. However, Einstein and others have since shown that Newton's laws have limitations. Newton's laws fail, for example, to explain successfully the motion of objects travelling at speeds close to the speed of light. They do not explain the bending of light by the gravitational forces exerted by stars, planets and other large bodies in the universe. However, they do successfully explain the motion of most objects at Earth's surface, the motion of satellites and the orbits of the planets that make up the solar system. In fact, it was Newton's laws that enabled NASA to plan the trajectories of artificial satellites.

### Changing motion

When explaining changes in motion, it is necessary to consider another property of the object — its mass. It is clear that it is more difficult, for example, to stop a truck moving at  $20 \text{ m s}^{-1}$  than it is to stop a tennis ball moving at the same speed. The physical quantity **momentum** is useful in explaining changes in motion, because it takes into account the mass as well as the velocity of a moving object.

The momentum  $p$  of an object is defined as the product of its mass  $m$  and its velocity  $v$ . Thus,

$$p = mv.$$

Momentum is a vector quantity that has the same direction as that of the velocity. The SI unit of momentum is  $\text{kg m s}^{-1}$ .

### Newton's First Law of Motion

*Every object continues in its state of rest or uniform motion unless made to change by a non-zero net force.*

**Momentum** is the product of the mass of an object and its velocity. Momentum is a vector quantity.

#### study on

Unit 3

Newton's first law

AOS 3

Summary screen and practice questions

Topic 1

Concept 1



**Net force** is the vector sum of all the forces acting on an object.

## REMEMBER THIS

The vector sum of the forces acting on an object is called the **net force**. It is usually denoted by the symbol  $F_{\text{net}}$ .

### study on

Unit 3

AOS 3

Topic 1

Concept 1



See more

Car moving with constant velocity

### eBook plus

eLesson

Newton's second law  
eles-0033

### study on

Unit 3

AOS 3

Topic 1

Concept 2

Newton's second law

Summary screen and practice questions

### study on

Unit 3

AOS 3

Topic 1

Concept 2



See more

Newton's second law

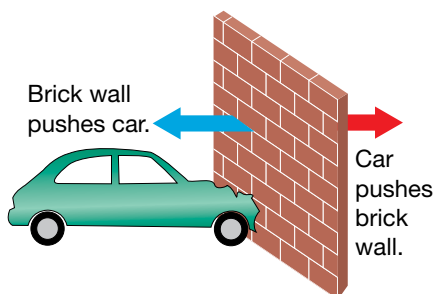

Newton's Third Law of Motion in action

Newton's First Law of Motion explains, for example, why you need to strike a golf ball with the club before it soars through the air. Without a **net force** acting on it, the golf ball will remain in its state of rest on the tee or grass (or sand, if you're having a bad day). It explains why seatbelts must be worn in a moving car and why you should never leave loose objects (like books, luggage or pets) in the back of a moving car. When a car stops suddenly, it does so because there is a large net force acting on it — as a result of braking or a collision. However, the large force does not act on you or the loose objects in the car. They continue their motion until stopped by a non-zero net force. Without a properly fitted seatbelt, you would move forward until stopped by the steering wheel, the windscreen or even the road. The loose objects in the car will also continue moving forward, posing a danger to anyone in the car.

Newton's First Law of Motion can also be expressed in terms of momentum by stating that the momentum of an object does not change unless the object is acted upon by a non-zero net force.

## Newton's Second Law of Motion

*The rate of change in momentum is directly proportional to the magnitude of the net force and is in the direction of the net force.*

This can be expressed algebraically as:

$$F_{\text{net}} = \frac{\Delta p}{\Delta t}$$

The net force can also be expressed in terms of the acceleration.

$$F_{\text{net}} = \frac{\Delta p}{\Delta t} = \frac{m\Delta v}{\Delta t} \quad (\text{provided the mass is constant})$$

$$\Rightarrow F_{\text{net}} = ma$$

This expression of Newton's Second Law of Motion is especially useful because it relates the net force to a description of the motion of objects. An acceleration of  $1 \text{ m s}^{-2}$  results when a net force of  $1 \text{ N}$  acts on an object of mass  $1 \text{ kg}$ .

## Newton's Third Law of Motion

*If object B applies a force to object A, then object A applies an equal and opposite force on object B:*

$$F_{\text{on A by B}} = -F_{\text{on B by A}}$$

It is important to remember that the forces that make up the force pair act on different objects. The subsequent motion of each object is determined by the net force acting on it. For example, the net force on the brick wall at left is the sum of the force applied to it by the car (shown by the red arrow) and all of the other forces acting on it. The force shown by the blue arrow is not applied to the brick wall and does not affect its motion. The net force on the car is the sum of the force applied by the brick wall (shown by the blue arrow) and all of the other forces acting on it.

## study on

Unit 3

**Newton's third law**

AOS 3

Summary screen and practice questions

Topic 1

Concept 3

## eBook plus

### Interactivity

Going up?

int-6606

## study on

Unit 3

AOS 3

Topic 1

Concept 3



**See more**

Examples of action–reaction pairs of forces

## Feeling lighter — feeling heavier

As you sit reading this, your weight force, the force on you by the Earth ( $W = mg$ ), is pulling you down towards the centre of the Earth, but the chair is in the way. The material in the chair is being compressed and pushes up on you. This force is called the normal reaction force ( $N$ ), because if you were not sitting on the chair, there would be no force. If these two forces, the weight force and the reaction force, balance, the net force on you is zero.

You 'feel' the Earth's pull on you because of Newton's third law. The upward compressive force on you by the chair is paired with the downward force on the chair by you. You sense this downward force through the compression in the bones in your pelvis.

What happens to these forces when you are in a lift? A lift going up initially accelerates upwards, then travels at a constant speed (no acceleration) and finally slows down (the direction of acceleration is downwards). You experience each of these stages differently.

### Accelerating upwards

When you are accelerating upwards, the net force on you is upwards. The only forces acting on you are your weight force down and the reaction force by the floor acting upwards. Your weight force is not going to change. So if the net force on you is up, then the reaction force on you must be greater than your weight force,  $N > mg$ .

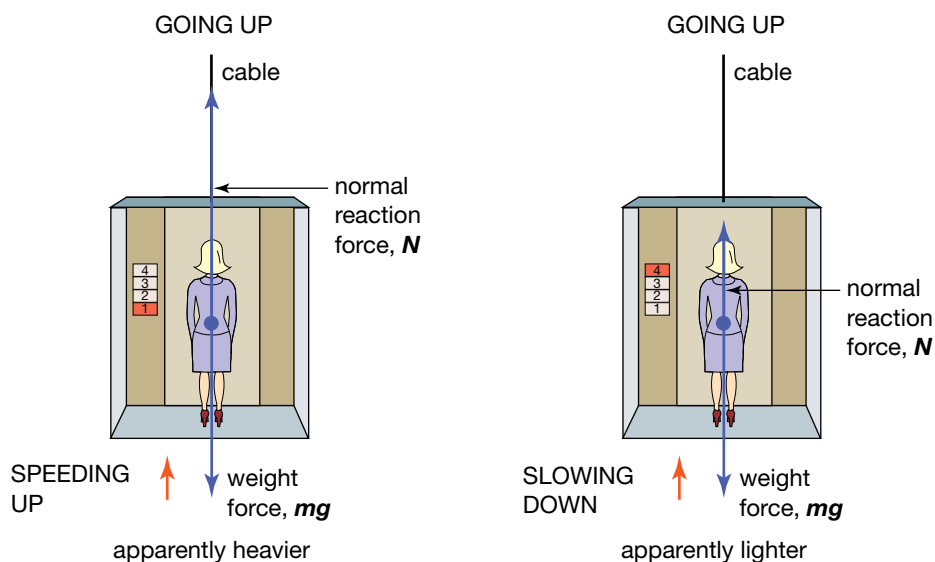

You sense your weight only because the floor pushes up on you. The magnitude of the normal reaction force determines how heavy you feel.

If the reaction force on you by the floor of the lift is greater than your weight force, then by Newton's third law, the force on the floor of the lift by you is also greater than your weight force. This means you feel a greater compression in the bones in your legs. You 'feel heavier'.

### Accelerating downwards

When you are accelerating downwards, the net force on you is downwards. So the reaction force on you must be less than your weight force,  $N < mg$ . You feel a lesser compression in the bones in your legs. You 'feel lighter'.

# Applying Newton's Second Law of Motion

The following sample problem shows how Newton's Second Law of Motion can be applied to single objects or to a system of two objects.

## Sample problem 1.4

A large car of mass 1600 kg starts from rest on a horizontal road with a forward thrust of 5400 N due east. The sum of the forces resisting the motion of the car is 600 N.

- Determine the acceleration of the car.
- The same car is used to tow a 400 kg trailer with the same forward thrust as before. The sum of the forces resisting the motion of the trailer is 200 N.
  - Determine the acceleration of the system of the car and the trailer.
  - What is the magnitude of the force exerted by the trailer on the car? (The force is labelled  $P_{tc}$  in the following figure.)

**Solution:** (a) A diagram must be drawn to show the forces acting on the car and trailer. The vertical forces can be omitted in this case because it is clear that the sum of the vertical forces is zero. (Otherwise, there would be a vertical component of acceleration.) The vertical forces have been omitted in the figure below.

Assign due east as positive.

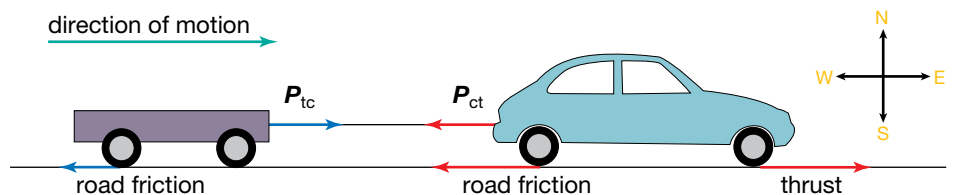

The net force on the car is:

$$\begin{aligned} F_{\text{net}} &= 5400 \text{ N} - 600 \text{ N} \\ &= 4800 \text{ N.} \end{aligned}$$

Applying Newton's second law to the car gives:

$$\begin{aligned} F_{\text{net}} &= ma \\ a &= \frac{F_{\text{net}}}{m} \\ &= \frac{4800 \text{ N}}{1600 \text{ kg}} \\ &= 3.0 \text{ m s}^{-2} \text{ east.} \end{aligned}$$

- (b) (i) The net force on the entire system is:

$$\begin{aligned} F_{\text{net}} &= 5400 \text{ N} - 600 \text{ N} - 200 \text{ N} \\ &= 4600 \text{ N.} \end{aligned}$$

Applying Newton's second law to the entire system gives:

$$\begin{aligned} F_{\text{net}} &= ma \\ \Rightarrow a &= \frac{F_{\text{net}}}{m} \\ &= \frac{4600 \text{ N}}{2000 \text{ kg}} \\ &= 2.3 \text{ m s}^{-2} \text{ east.} \end{aligned}$$

- (ii) Newton's second law can be applied to either the car or the trailer to answer this question.

*Method 1:* Applying Newton's second law to the car gives:

$$\begin{aligned} F_{\text{net}} &= ma \\ &= 1600 \text{ kg} \times 2.3 \text{ m s}^{-2} \end{aligned}$$

$$\Rightarrow F_{\text{net}} = 3680 \text{ N.}$$

The net force on the car is also given by:

$$F_{\text{net}} = 5400 \text{ N} - 600 \text{ N} - P_{\text{tc}}$$

(where  $P_{\text{tc}}$  is the magnitude of the force exerted by the trailer on the car)

$$\Rightarrow 3680 \text{ N} = 5400 \text{ N} - 600 \text{ N} - P_{\text{tc}}$$

$$\begin{aligned} \Rightarrow P_{\text{tc}} &= 5400 \text{ N} - 600 \text{ N} - 3680 \text{ N} \\ &= 1120 \text{ N.} \end{aligned}$$

*Method 2:* Applying Newton's second law to the trailer gives:

$$\begin{aligned} F_{\text{net}} &= ma \\ &= 400 \text{ kg} \times 2.3 \text{ m s}^{-2} \end{aligned}$$

$$\Rightarrow F_{\text{net}} = 920 \text{ N.}$$

The net force on the trailer is also given by:

$$F_{\text{net}} = P_{\text{ct}} - 200 \text{ N}$$

(where  $P_{\text{ct}}$  is the magnitude of the force exerted by the car on the trailer)

$$\Rightarrow 920 \text{ N} = P_{\text{ct}} - 200 \text{ N}$$

$$\begin{aligned} \Rightarrow P_{\text{ct}} &= 920 \text{ N} + 200 \text{ N} \\ &= 1120 \text{ N.} \end{aligned}$$

Applying Newton's third law,  $P_{\text{tc}} = 1120 \text{ N}$ .

#### Revision question 1.4

- (a) A car of mass 1400 kg tows a trailer of mass 600 kg due north along a level road at constant speed. The forces resisting the motion of the car and trailer are 400 N and 100 N respectively.

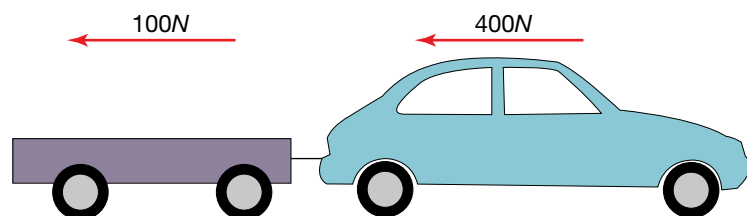

- (i) Determine the forward thrust applied to the car.  
 (ii) What is the magnitude of the tension in the bar between the car and the trailer?
- (b) If the car and trailer in part (a), with the same resistance forces, have a northerly acceleration of  $2.0 \text{ m s}^{-2}$ , what is:
- the net force applied to the trailer
  - the magnitude of the tension in the bar between the car and the trailer
  - the forward thrust applied to the car?

## study on

Unit 3

AOS 3

Topic 1

Concept 4

### Application – forces on a moving bicycle on level ground

Summary screen and practice questions

## study on

Unit 3

AOS 3

Topic 1

Concept 4



### See more

Forces acting on a moving bicycle on level ground

## Handy tips for using Newton's second law

Below are some handy tips for using Newton's Second Law of Motion.

1. Draw a diagram of the system.
2. Use clearly labelled diagrams to represent the forces acting on each object in the system. The diagram can be simplified, if necessary, by drawing all of the forces as though they were acting through the centre of mass.
3. Apply Newton's second law to the system and/or each individual object until you have the information you need.

## On the level

Whether you are walking on level ground, driving a car, riding in a roller-coaster or flying in the space shuttle, your motion is controlled by the net force acting on you.

The figure below shows the forces acting on a car moving at a constant velocity on a level surface.

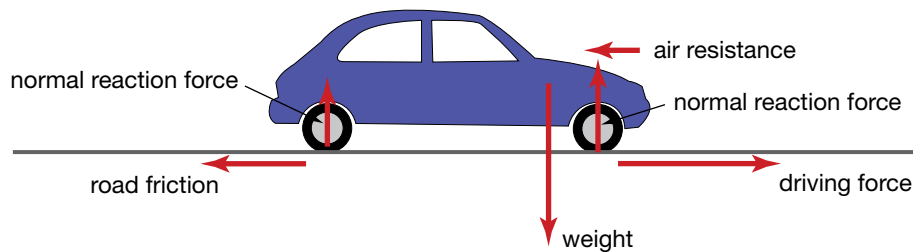

Forces acting on a car moving on a level surface. The car's engine is making the front wheels turn.

The forces acting on the car are described below.

- **Weight.** The weight of an object is equal to the pull of gravity on it and is usually given the symbol  $W$ . The weight of an object is given by:

$$W = mg$$

where

$m$  = mass

$g$  = gravitational field strength.

Throughout this text, the magnitude of  $g$  at Earth's surface will be taken as  $9.8 \text{ N kg}^{-1}$ . The weight of a medium-sized sedan carrying a driver and passenger is about 15 000 N.

- **Normal reaction.** The normal reaction force is the upward push of the surface. A normal reaction force acts on all four wheels of the car. It is described as a *normal* force because it acts at right angles to the surface. It is described as a *reaction* force because it acts in response to the force that the object applies to the surface. Unless the surface itself is accelerating up or down, the force applied to the surface by the object is the same as the weight of the object. The total normal reaction force is therefore equal and opposite in direction to the weight force.
- **Driving force.** The force that pushes the car forward is provided at the driving wheels — the wheels that are turned by the motor. In most cars, either the front wheels or the rear wheels are the driving wheels. The motor of a four-wheel drive pushes all four wheels. As the tyres push back on the road, the road pushes forward on the tyres, propelling the car forward. The forward push of the road on the tyres is a frictional force, as it is the resistance to movement of one surface across another. In this case, it is the force that prevents the tyres from sliding across the road. If the road or tyres are too smooth, the driving force is reduced, the tyres slide backwards and the wheels spin.

**Air resistance** is the force applied to an object opposite to its direction of motion, by the air through which it is moving.

**Road friction** is the force applied by the road surface to the wheels of a vehicle in a direction opposite to the direction of motion of the vehicle.

The **centre of mass** is the point at which all of the mass of an object can be considered to be when modelling the external forces acting on the object.

- **Resistance forces.** As the car moves, it applies a force to the air in front of it. The air applies an equal force opposite to its direction of motion. This force is called **air resistance**. The air resistance on an object increases as its speed increases. The other resistance force acting on the car is **road friction**. It opposes the forward motion of the non-driving wheels, rotating them in the same direction as the driving wheels. In the car in the previous figure, the front wheels are the driving wheels. Road friction opposes the motion of the rear wheels along the road and, therefore, the forward motion of the car. This road friction is an example of rolling friction, which is considerably smaller than both the sliding friction that acts when the brakes are applied and the friction that acts on the driving wheels.

### The centre of mass

The forces on a moving car do not all act at the same point on the car. When analysing the translational motion of an object (its movement across space without considering rotational motion), all of the forces applied to an object can be considered to be acting at one particular point. That point is the **centre of mass**. The centre of mass of a symmetrical object with uniform mass distribution is at the centre of the object. For example, the centre of mass of each of a ruler, a solid ball or an ice cube is at the centre. However, the centre of mass of a person or a car is not.

#### AS A MATTER OF FACT

If you hold an object like a ruler at its centre of mass, it will balance. However, the centre of mass does not have to be within the object. For example, the centre of mass of a doughnut is in its centre. A high-jumper can improve her performance by manoeuvring her body over the bar so that her centre of mass is below the bar. The centre of gravity of an object is a point through which the gravitational force can be considered to act. For most objects near Earth's surface, it is reasonable to assume that the centre of mass is at the same point as the centre of gravity. This is because the gravitational field strength is approximately constant at Earth's surface.



Where is the centre of mass of a boomerang? Try balancing a boomerang in a horizontal plane on one finger.

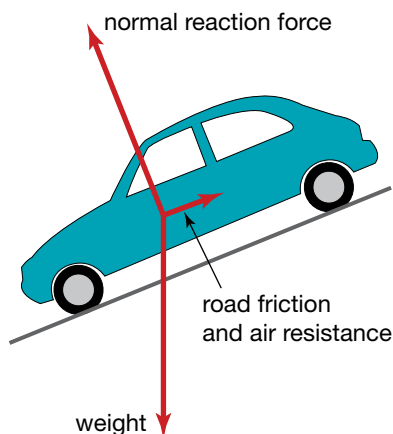

The forces acting on a car rolling down an inclined plane

### Inclined to move

The forces acting on objects on an inclined plane are similar to those acting on the same objects on a level surface. However, the direction of some of the forces is different. As a result, the direction of net force may also be different.

The forces acting on a car rolling down an inclined plane are shown in the figure at left. In order to simplify the diagram, all the forces are modelled

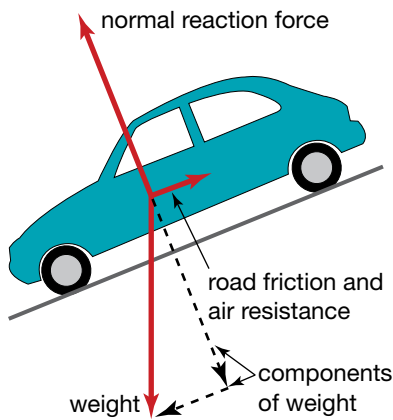

Forces can be resolved into components. In this case, the weight has been resolved into two components. This makes it clear that the net force is parallel to the inclined plane.

as if they were acting through the centre of mass of the car. The car is then considered to behave like a single particle and the rotational motion of the wheels is ignored.

### Resolving forces into components

The net force on a car can be found by finding the vector sum of the forces acting on it. It is also helpful in analysing the forces and subsequent motion of the car to 'break up', or resolve, the forces into components. The figure at left shows how the weight can be resolved into two components — one parallel to the surface and one perpendicular to the surface.

By resolving the weight into these components, the analysis of the forces and subsequent motion of the car is made simpler. Consider the forces perpendicular to the inclined plane. It can be seen in the figure at left that the magnitude of the normal reaction force is equal to the component of weight that is perpendicular to the surface. Thus the net force has no component perpendicular to the surface. (Imagine what would happen if this wasn't the case!)

Now consider the forces parallel to the inclined plane. The horizontal component of the weight is greater than the sum of road friction and air resistance. The net force is therefore parallel to the surface. The car will accelerate down the slope.

### Sample problem 1.5

A downhill snow skier of mass 70 kg is moving down a slope inclined at  $15^\circ$  to the horizontal with a constant velocity.

Determine:

- the normal reaction force
- the sum of the resistance forces acting on the skier.

**Solution:** A diagram must be drawn to show the forces acting on the skier.

- The net force on the skier has no component perpendicular to the surface of the snow. Thus:

$$\begin{aligned}
 N &= W_y \\
 &= W \cos 15^\circ \quad (\text{since } \cos 15^\circ = \frac{W_y}{W} \Rightarrow W_y = W \cos 15^\circ) \\
 &= mg \cos 15^\circ \\
 &= 70 \text{ kg} \times 9.8 \text{ N kg}^{-1} \times \cos 15^\circ \\
 &= 663 \text{ N, rounded to } 660 \text{ N.}
 \end{aligned}$$

The normal reaction force is therefore 660 N in the direction perpendicular to the surface as shown.

- The net force on the skier in the direction parallel to the surface is zero. We know this because the skier has a constant velocity. The magnitude of the sum of resistance forces therefore must be equal to the component of the weight that is parallel to the surface.

$$\begin{aligned}
 R &= W_x \\
 &= W \sin 15^\circ \quad (\text{since } \sin 15^\circ = \frac{W_x}{W} \Rightarrow W_x = W \sin 15^\circ) \\
 &= mg \sin 15^\circ \\
 &= 70 \text{ kg} \times 9.8 \text{ N kg}^{-1} \times \sin 15^\circ \\
 &= 178 \text{ N, rounded to } 180 \text{ N}
 \end{aligned}$$

The sum of the resistance forces (air resistance and friction) acting on the skier is 180 N opposite to the direction of motion.

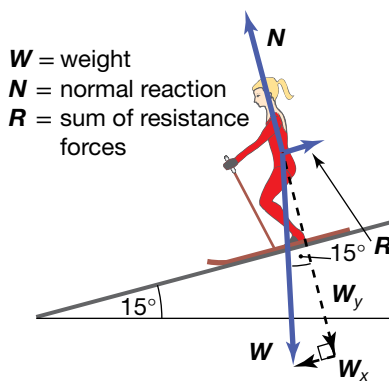

$W$  = weight  
 $N$  = normal reaction  
 $R$  = sum of resistance forces

### study on

**Unit 3** Projectile motion — horizontal and vertical  
**AOS 3**  
**Topic 1**

**Concept 7** Summary screen and practice questions

## study on

Unit 3

AOS 3

Topic 1

Concept 7



See more

Parabolic motion of a projectile

## study on

Unit 3

AOS 3

Topic 1

Concept 6

**Projectile motion – vertical**

Summary screen and practice questions

## eBook plus

### eLessons

Ball toss

eles-0031

Air resistance

eles-0035

## Revision question 1.5

- (a) A cyclist rides at constant speed up a hill that is inclined at  $15^\circ$  to the horizontal. The total mass of the cyclist and bicycle is 90 kg. The sum of the road friction and air resistance on the cyclist and bicycle is 20 N. Determine:
- the forward driving force provided by the road on the bicycle
  - the normal reaction force.
- (b) If the cyclist in part (a) coasts down the same hill with a constant total resistance of 50 N, what is the cyclist's acceleration?

## Projectile motion

Any object that is launched into the air is a projectile. A basketball thrown towards a goal, a trapeze artist soaring through the air, and a package dropped from a helicopter are all examples of projectiles.

Except for those projectiles whose motion is initially straight up or down, or those that have their own power source (like a guided missile), projectiles generally follow a parabolic path. Deviations from this path can be caused either by air resistance, by spinning of the object or by wind. These effects are often small and can be ignored in many cases. A major exception, however, is the use of spin in many ball sports, but this effect will not be dealt with in this book.

## Falling down

Imagine a ball that has been released some distance above the ground. Once the ball is set in motion, the only forces acting on it are gravity (straight down) and air resistance (straight up).

After the ball is released, the projection device (hand, gun, slingshot or whatever) stops exerting a downwards force.

The net force on the ball in the figure at right is downwards. As a result, the ball accelerates downwards. If the size of the forces and the mass of the ball are known, the acceleration can be calculated using Newton's Second Law of Motion.

Often the force exerted on the ball by air resistance is very small in comparison to the force of gravity, and so can be ignored. This makes it possible to model projectile motion by assuming that the acceleration of the ball is due only to gravity and is a constant  $9.8 \text{ m s}^{-2}$  downwards.

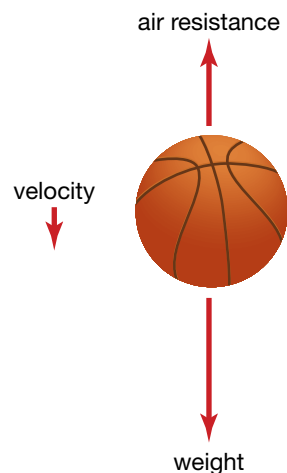

The forces acting on a ball falling downwards

## Sample problem 1.6

A helicopter delivering supplies to a flood-stricken farm hovers 100 m above the ground. A package of supplies is dropped from rest, just outside the door of the helicopter. Air resistance can be ignored.

- Calculate how long it takes the package to reach the ground.
- Calculate how far from its original position the package has fallen after 0.50 s, 1.0 s, 1.5 s, 2.0 s etc. until the package has hit the ground. (You may like to use a spreadsheet here.) Draw a scale diagram of the package's position at half-second intervals.



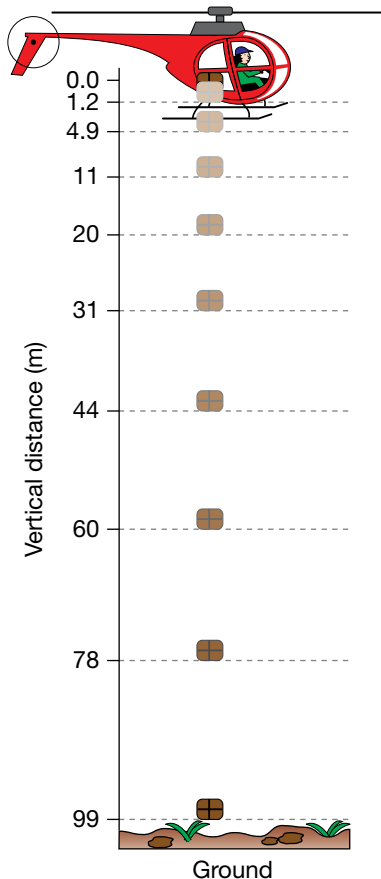

**Solution:** (a)  $u = 0 \text{ m s}^{-1}$ ,  $s = 100 \text{ m}$ ,  $a = 9.8 \text{ m s}^{-2}$ ,  $t = ?$

$$s = ut + \frac{1}{2}at^2$$

$$100 \text{ m} = 0 \text{ m s}^{-1} \times t + \frac{1}{2} (9.8 \text{ m s}^{-2})t^2$$

$$\frac{100}{4.9} = t^2$$

$$t = 4.52 \text{ s, rounded to 4.5 s}$$

(Note: The negative square root can be ignored here as we are interested only in motion that has occurred after the package was released at  $t = 0$ , i.e. positive times.)

(b)  $t = 0.50 \text{ s}$ ,  $u = 0 \text{ m s}^{-1}$ ,  $a = 9.8 \text{ m s}^{-2}$ ,  $s = ?$

$$s = ut + \frac{1}{2}at^2$$

$$= 0 \times 0.5 \text{ s} + \frac{1}{2} (9.8 \text{ m s}^{-2})(0.5 \text{ s})^2$$

$$= 1.23 \text{ m, rounded to 1.2 m}$$

Repeat this for  $t = 1 \text{ s}$ ,  $1.5 \text{ s}$ ,  $2 \text{ s}$  etc. to gain the results listed in the following table and illustrated at left.

**TABLE 1.1** Vertical distance travelled over time

Time (s)	0.50	1.0	1.5	2.0	2.5	3.0	3.5	4.0	4.5
Vertical distance (m)	1.2	4.9	11	20	31	44	60	78	99

### Revision question 1.6

A camera is dropped by a tourist from a lookout and falls vertically to the ground. The thud of the camera hitting the hard ground below is heard by the tourist 3.0 seconds later. Air resistance and the time taken for the sound to reach the tourist can be ignored.

- (a) How far did the camera fall?
- (b) What was the velocity of the camera when it hit the ground below?

### Terminal velocity

The air resistance on a falling object increases as its velocity increases. An object falling from rest initially experiences no air resistance. As the object accelerates due to gravity, the air resistance increases. Eventually, if the object doesn't hit a surface first, the air resistance will become as large as the object's weight. The net force on it becomes zero and the object continues to fall with a constant velocity, referred to as its **terminal velocity**.

### Moving and falling

If a ball is thrown horizontally, the only force acting on the ball once it has been released is gravity (ignoring air resistance). As the force of gravity is the same regardless of the motion of the ball, the ball will still accelerate downwards at the same rate as if it were dropped. There will not be any horizontal acceleration

A falling object reaches its **terminal velocity** when the upwards air resistance becomes equal to the downward force of gravity.

as there is no net force acting horizontally. This means that while the ball's vertical velocity will change, its horizontal velocity remains the same throughout its motion.

It is the constant horizontal velocity and changing vertical velocity that give projectiles their characteristic parabolic motion.

Notice that the vertical distance travelled by the ball in each time period increases, but that the horizontal distance is constant.

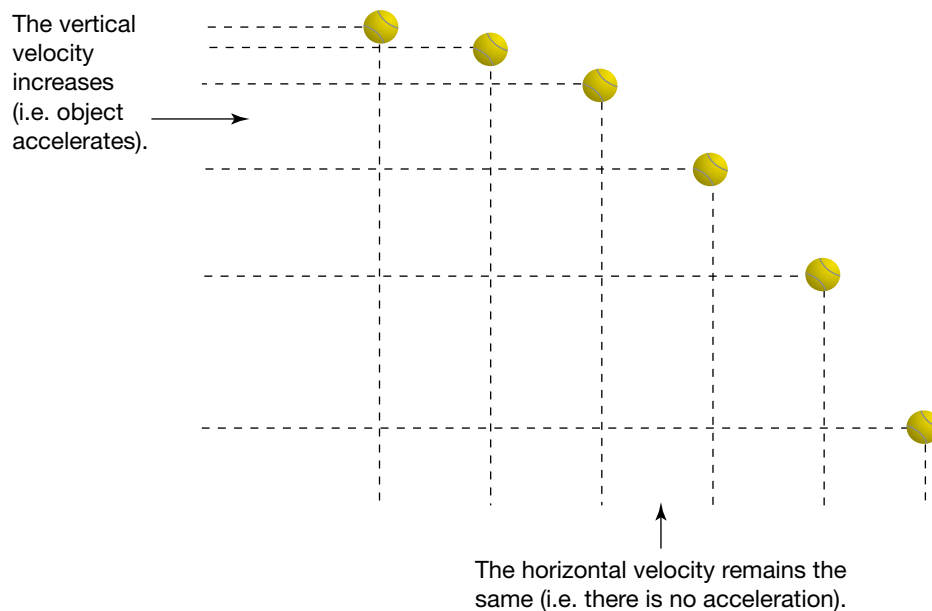

Position of a ball at constant time intervals

### Keep them separated

In modelling projectile motion, the vertical and horizontal components of the motion are treated separately.

1. The total time taken for the projectile motion is determined by the vertical part of the motion as the projectile cannot continue to move horizontally once it has hit the ground, the target or whatever else it might collide with.
2. This total time can then be used to calculate the horizontal distance, or range, over which the projectile travels.

### Sample problem 1.7

Imagine the helicopter described in sample problem 1.6 is not stationary, but is flying at a slow and steady speed of  $20 \text{ m s}^{-1}$  and is  $100 \text{ m}$  above the ground when the package is dropped.

- (a) Calculate how long it takes the package to hit the ground.
- (b) What is the range of the package?
- (c) Calculate the vertical distance the package has fallen after  $0.50 \text{ s}$ ,  $1.0 \text{ s}$ ,  $1.5 \text{ s}$ ,  $2.0 \text{ s}$ , etc. until the package has reached the ground. (You may like to use a spreadsheet here.) Then calculate the corresponding horizontal distance, and hence draw a scale diagram of the package's position at half-second intervals.

Remember, the horizontal and vertical components of the package's motion must be considered separately.

**Solution:** (a) In this part of the question the vertical component is important. Vertical component:  $u = 0 \text{ m s}^{-1}$ ,  $s = 100 \text{ m}$ ,  $a = 9.8 \text{ m s}^{-2}$ ,  $t = ?$

$$s = ut + \frac{1}{2}at^2$$

$$100 \text{ m} = 0 \text{ m s}^{-1} \times t + \frac{1}{2}(9.8 \text{ m s}^{-2})t^2$$

$$\frac{100}{4.9} = t^2$$

$$t = 4.52 \text{ s, rounded to 4.5 s}$$

(Note: Again, the positive square root is taken as we are concerned only with what happens after  $t = 0$ .)

(b) The range of the package is the horizontal distance over which it travels. It is the horizontal component of velocity that must be used here.

Horizontal component:  $u = 20 \text{ m s}^{-1}$  (The initial velocity of the package is the same as the velocity of the helicopter in which it has been travelling.)

$a = 0 \text{ m s}^{-2}$  (No forces act horizontally so there is no horizontal acceleration.)

$t = 4.5 \text{ s}$  (from part (a) of this example)

$s = ?$

$$s = ut + \frac{1}{2}at^2$$

$$= 20 \text{ m s}^{-1} \times 4.5 \text{ s} + 0$$

$$= 90 \text{ m}$$

(c)

**TABLE 1.2** Vertical and horizontal components of the package's motion

Vertical component	Horizontal component
$u = 0 \text{ m s}^{-1}$ , $t = 0.50 \text{ s}$ , $a = 10 \text{ m s}^{-2}$ , $s = ?$	$u = 20 \text{ m s}^{-1}$ , $t = 0.50 \text{ s}$ , $a = 0 \text{ m s}^{-2}$ , $s = ?$
$s = ut + \frac{1}{2}at^2$	$s = ut + \frac{1}{2}at^2$
$= 0 \text{ m s}^{-1} \times 0.50 \text{ s} + \frac{1}{2}(10 \text{ m s}^{-2})(0.5 \text{ s})^2$	$= 20 \text{ m s}^{-1} \times 0.50 \text{ s} + 0$
$= 1.2 \text{ m}$	$= 10 \text{ m}$

Repeat the calculations shown in table 1.2 for  $t = 1.0 \text{ s}$ ,  $1.5 \text{ s}$ ,  $2.0 \text{ s}$ , etc. to gain the results shown in table 1.3. The scale diagram of the package's position is shown on page 22.

**TABLE 1.3** Vertical and horizontal distance travelled over time

Time (s)	Vertical distance (m)	Horizontal distance (m)
0.50	1.2	10
1.0	4.8	20
1.5	11	30
2.0	20	40
2.5	31	50
3.0	44	60
3.5	60	70
4.0	78	80
4.5	99	90

**eBookplus**

**eModelling**

Falling from a helicopter

doc-0033

## Digital doc

Investigation 1.1

Predicting the range of a projectile

doc-18534

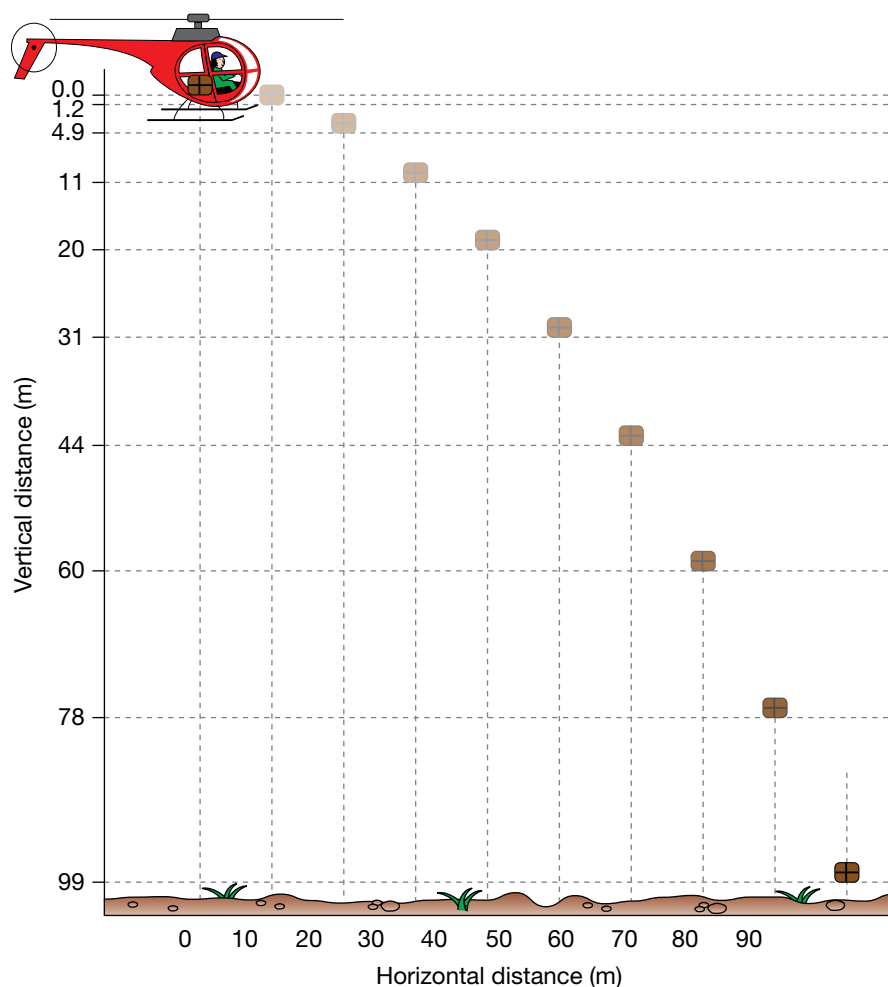

## Revision question 1.7

A ball is thrown horizontally at a speed of  $40 \text{ m s}^{-1}$  from the top of a cliff into the ocean below and takes 4.0 seconds to land in the water. Air resistance can be ignored.

- What is the height of the cliff above sea level if the thrower's hand releases the ball from a height of 2.0 metres above the ground?
- What horizontal distance did the ball cover?
- Calculate the vertical component of the velocity at which the ball hits the water.
- At what angle to the horizontal does the ball strike the water?

## What goes up must come down

Most projectiles are set in motion with velocity. The simplest case is that of a ball thrown directly upwards. The only force acting on the ball is that of gravity (ignoring air resistance). The ball accelerates downwards. Initially, this results in the ball slowing down. Eventually, it comes to a halt, then begins to move downwards, speeding up as it goes.

Notice that, when air resistance is ignored, the motion of the ball is identical whether it is going up or coming down. The ball will return with the same speed with which it was projected. Throughout the motion illustrated in the

figure below (and for which graphs are shown), the acceleration of the ball is a constant  $10 \text{ m s}^{-2}$  downwards. A common error made by physics students is to suggest that the acceleration of the ball is zero at the top of its flight. If this were true, would the ball ever come down?

(a) going up

(b) going down

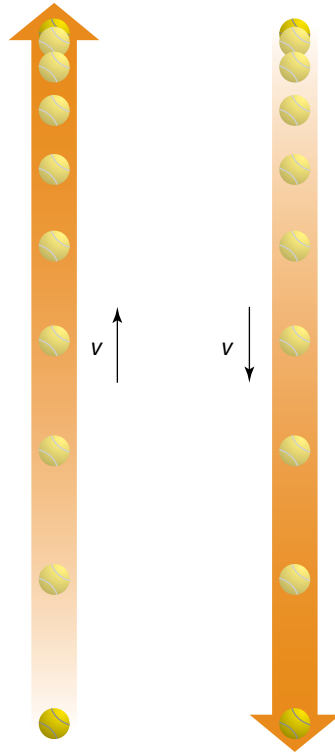

The motion of a ball projected vertically upwards

(a)

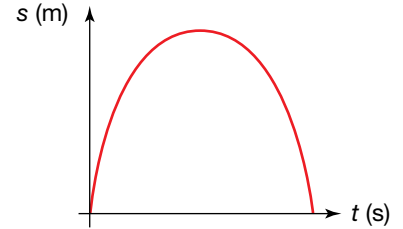

(b)

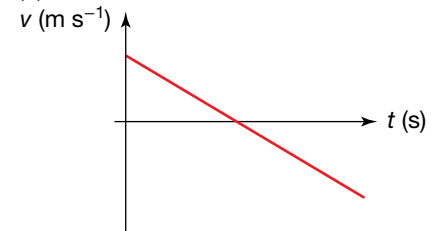

(c)

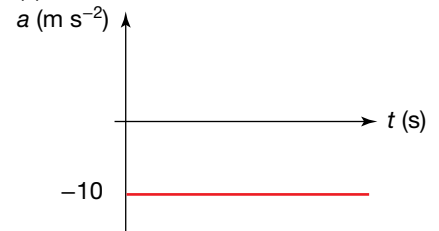

Graphs of motion for a ball thrown straight upwards

### AS A MATTER OF FACT

The axiom ‘what goes up must come down’ applies equally so to bullets as it does to balls. Unfortunately, this means that people sometimes get killed when they shoot guns straight up into the air. If the bullet left the gun at a speed of  $60 \text{ m s}^{-1}$ , it will return to Earth at roughly the same speed. This speed is well and truly fast enough to kill a person who is hit by the returning bullet.

### Sample problem 1.8

A dancer jumps vertically upwards with an initial velocity of  $4.0 \text{ m s}^{-1}$ . Assume the dancer’s centre of mass was initially  $1.0 \text{ m}$  above the ground, and ignore air resistance.

- How long did the dancer take to reach her maximum height?
- What was the maximum displacement of the dancer’s centre of mass?
- What is the acceleration of the dancer at the top of her jump?
- Calculate the velocity of the dancer’s centre of mass when it returns to its original height above the ground.

**Solution:** There are several ways of arriving at the same answer. As has been done in this example, it is always good practice to minimise the use of answers from previous parts of a question. This makes your answers more reliable, preventing a mistake made earlier on from distorting the accuracy of your later calculations. For this problem, assign up as positive and down as negative.

- (a)  $u = 4.0 \text{ m s}^{-1}$ ,  $a = -9.8 \text{ m s}^{-2}$ ,  $v = 0 \text{ m s}^{-1}$  (as the dancer comes to a halt at the highest point of the jump),  $t = ?$

$$v = u + at$$

$$0 \text{ m s}^{-1} = 4.0 \text{ m s}^{-1} + (-9.8 \text{ m s}^{-2}) \times t$$

$$t = \frac{4.0 \text{ m s}^{-1}}{9.8 \text{ m s}^{-2}}$$

$$= 0.41 \text{ s}$$

The dancer takes 0.41 s to reach her highest point.

- (b)  $u = 4.0 \text{ m s}^{-1}$ ,  $a = -9.8 \text{ m s}^{-2}$ ,  $v = 0 \text{ m s}^{-1}$  (as the dancer comes to a halt at the highest point of the jump),  $s = ?$

$$v^2 = u^2 + 2as$$

$$(0 \text{ m s}^{-1})^2 = (4.0 \text{ m s}^{-1})^2 + 2(-9.8 \text{ m s}^{-2})s$$

$$16 \text{ m} = 19.6s$$

$$s = 0.82 \text{ m}$$

The maximum displacement of the dancer's centre of mass is 0.80 m.

- (c) At the top of the jump, the only force acting on the dancer is the force of gravity (the same as at all other points of the jump). Therefore the acceleration of the dancer is acceleration due to gravity:  $9.8 \text{ m s}^{-2}$  downwards.
- (d) For this calculation, only the downwards motion needs to be investigated.

$u = 0 \text{ m s}^{-1}$  (as the dancer comes to a halt at the highest point of the jump),  
 $a = -9.8 \text{ m s}^{-2}$ ,  $s = -0.82 \text{ m}$  (as the motion is downwards),  $v = ?$

$$v^2 = u^2 + 2as$$

$$v^2 = (0 \text{ m s}^{-1})^2 + 2(-9.8 \text{ m s}^{-2})(-0.82 \text{ m})$$

$$v = -4.0 \text{ m s}^{-1}$$

(Note: Here, the negative square root is used, as the dancer is moving downwards. Remember, the positive and negative signs show direction only.)

The velocity of the dancer's centre of mass when it returns to its original height is  $4.0 \text{ m s}^{-1}$  downwards.

### Revision question 1.8

A basketball player jumps directly upwards so that his centre of mass reaches a maximum displacement of 50 cm.

- (a) What is the velocity of the basketballer's centre of mass when it returns to its original height above the ground?
- (b) For how long was the basketballer's centre of mass above its original height?

## PHYSICS IN FOCUS

### Hanging in mid air

Sometimes dancers, basketballers and high jumpers seem to hang in mid air. It is as though the force of gravity had temporarily stopped acting on them. Of course this is not so! It is only the person's centre of mass that moves in a parabolic path. The arrangement of the person's body can change the position of the centre of mass, causing the body to appear to be hanging in mid air even though the centre of mass is still following its original path.

High jumpers can use this effect to increase the height of their jumps. By bending her body as she passes over the bar, a high jumper can cause her centre of mass to be outside her body! This allows her body to pass over the bar, while her centre of mass passes under it. The amount of energy available to raise the high jumper's centre of mass is limited, so she can raise her centre of mass only by a certain amount. This technique allows her to clear a higher bar than other techniques for the same amount of energy.



Croatian high jumper Ana Simic's centre of mass passes under the bar, while her body passes over the bar!

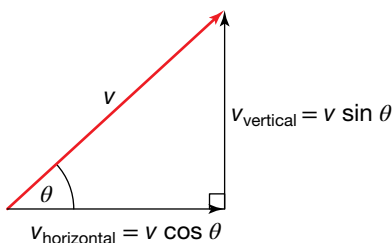

The velocity can be resolved into a vertical and a horizontal component.

### Shooting at an angle

Generally, projectiles are shot, thrown or driven at some angle to the horizontal. In these cases the initial velocity may be resolved into its horizontal and vertical components to help simplify the analysis of the motion.

If the velocity and the angle to the horizontal are known, the size of the components can be calculated using trigonometry.

The motion of projectiles with an initial velocity at an angle to the horizontal can be dealt with in exactly the same manner as those with a velocity straight up or straight across. However, the initial velocity must be separated into its vertical and horizontal components.

### Sample problem 1.9

A stunt driver is trying to drive a car over a small river. The car will travel up a ramp (at an angle of  $40^\circ$ ) and leave the ramp travelling at  $22 \text{ m s}^{-1}$ . The river is 50 m wide. Will the car make it?

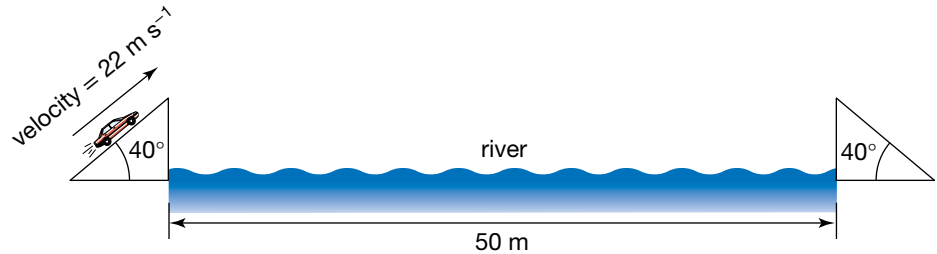

**Solution:** Assign up as positive and down as negative.

Before either part of the motion can be examined, it is important to calculate the vertical and horizontal components of the initial velocity.

#### eBookplus

eModelling  
Free throw shooter  
doc-0034

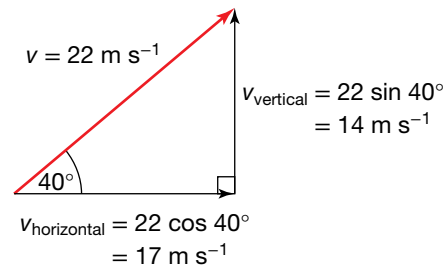

Therefore the initial vertical velocity is  $14 \text{ m s}^{-1}$  and the initial horizontal velocity is  $17 \text{ m s}^{-1}$ .

In order to calculate the range of the car (how far it will travel horizontally), it is clear that the horizontal part of its motion must be considered. However, the vertical part is also important. The vertical motion is used to calculate the time in the air. Then, the horizontal motion is used to calculate the range.

**TABLE 1.4** Calculating the horizontal and vertical components

Vertical component	Horizontal component
<p>(Use the first half of the motion — from take-off until the car has reached its highest point.)</p> <p><math>u = 14 \text{ m s}^{-1}</math>, <math>a = -9.8 \text{ m s}^{-2}</math>,  <math>v = 0 \text{ m s}^{-1}</math> (as the car comes to a vertical halt at its highest point),  <math>t = ?</math></p> <p><math>v = u + at</math></p> <p><math>0 = 14 \text{ m s}^{-1} + (-9.8 \text{ m s}^{-2}) \times t</math></p> <p><math>t = \frac{14 \text{ m s}^{-1}}{9.8 \text{ m s}^{-2}}</math></p> <p><math>= 1.4 \text{ s}</math></p> <p>As this is only half the motion, the total time in the air is 2.8 s. (It is possible to double the time in this situation because we have ignored air resistance. The two parts of the motion are symmetrical.)</p>	<p><math>u = 17 \text{ m s}^{-1}</math>, <math>t = 2.8 \text{ s}</math> (being twice the time taken to reach maximum height as calculated for the vertical component),  <math>a = 0 \text{ m s}^{-2}</math>, <math>s = ?</math></p> <p><math>s = ut</math></p> <p><math>= 17 \text{ m s}^{-1} \times 2.8 \text{ s}</math></p> <p><math>= 48 \text{ m}</math></p>



Therefore, the unlucky stunt driver will fall short of the second ramp and will land in the river. Maybe the study of physics should be a prerequisite for all stunt drivers!

### Revision question 1.9

A hockey ball is hit towards the goal at an angle of  $25^\circ$  to the ground with an initial speed of  $32 \text{ km h}^{-1}$ .

- What are the horizontal and vertical components of the initial velocity of the ball?
- How long does the ball spend in flight?
- What is the range of the hockey ball?

## Projectile motion calculations

Here are some tips for projectile motion calculations.

- It helps to draw a diagram.
- Always separate the motion into vertical and horizontal components.
- Remember to resolve the initial velocity into its components if necessary.
- The time in flight is the link between the separate vertical and horizontal components of the motion.
- At the end of any calculation, check to see if the quantities you have calculated are reasonable.

## The real world – including air resistance

So far in this chapter, the effects of air resistance have been ignored so that we can easily model projectile motion. The reason the force of air resistance complicates matters so much is that it is not constant throughout the motion. It depends on the velocity of the projectile, the surface area that is being hit by the air, the type of surface and even the spin of the projectile. For objects with the same surface and spin, air resistance increases as the speed of the object increases.

No matter what affects the amount of air resistance, one thing is always true — air resistance opposes the motion of the projectile.

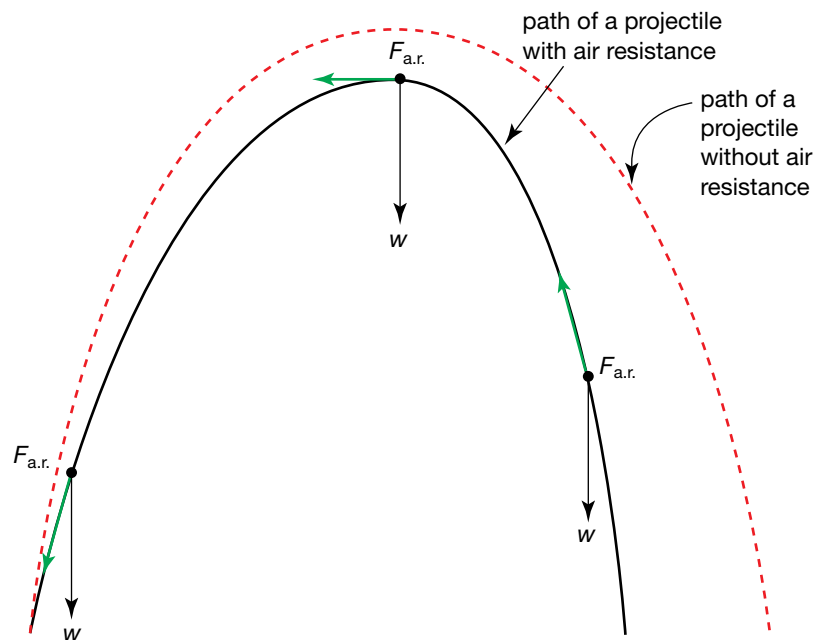

While the magnitude of air resistance changes throughout the motion, it always opposes the direction of the motion.

## study on

Unit 3

**Motion in a vertical plane (1)**

AOS 3

Topic 4

Summary screen and practice questions

Concept 3

## study on

Unit 3

**Motion in a vertical plane (2)**

AOS 3

Topic 4

Summary screen and practice questions

Concept 4

## Uniform circular motion

Humans seem to spend a lot of time going around in circles. Traffic at roundabouts, children on merry-go-rounds, cyclists in velodromes. If you stop to think about it, you are always going around in circles as a result of Earth's rotation.

The satellites orbiting Earth, including the Moon, travel in ellipses. However, their orbits can be modelled as circular motion.



The motion of satellites around Earth can be modelled as circular motion with a constant speed.



## Getting nowhere fast

Ralph has been a bad dog and has been chained up. To amuse himself, he runs in circles. Ralph's owner, Julie, is a physics teacher. She knows that no matter how great Ralph's average speed is, he always ends up in the same place, so his average velocity is always zero.

## Instantaneous velocity

Although Ralph's average velocity for a single lap is zero, his instantaneous velocity is continually changing. Velocity is a vector and has a magnitude and direction. While the magnitude of Ralph's velocity may be constant, the direction is continually changing. At one point, Ralph is travelling east, so his instantaneous velocity is in an easterly direction. A short time later, he will be travelling south, so his instantaneous velocity is in a southerly direction.

If Ralph could maintain a constant speed, the magnitude of his velocity would not change, but the direction would be continually changing.

The speed is therefore constant and can be calculated using the formula  $v = \frac{x}{t}$ , where  $v$  is the average speed,  $x$  is the distance travelled and  $t$  is the time interval. It is most convenient to use the **period** of the object travelling in a circle. Thus:

$$\begin{aligned}v &= \frac{\Delta x}{\Delta t} \\ &= \frac{\text{circumference}}{\text{period}} \\ &= \frac{2\pi r}{T}\end{aligned}$$

where

$r$  = radius of the circle

$T$  = period.

The **period** of a repeated circular motion is the time taken for a complete revolution.

### Sample problem 1.10

Ralph's chain is 7.0 m long and attached to a small post in the middle of the garden. It takes an average of 9 s to complete one lap.

- What is Ralph's average speed?
- What is Ralph's average velocity after three laps?
- What is Ralph's instantaneous velocity at point A? (Assume he travels at a constant rate around the circle.)

**Solution:** (a) To calculate Ralph's speed, we need to know how far he has travelled. Using the formula for the circumference of a circle (distance =  $2\pi r$ ):

$$\begin{aligned}\text{distance} &= 2 \times \pi \times 7.0 \text{ m} \\ &= 44 \text{ m}.\end{aligned}$$

Now the average speed can be calculated.

$$\begin{aligned}v &= \frac{x}{t} \\ &= \frac{44 \text{ m}}{9 \text{ s}} \\ &= 5 \text{ m s}^{-1}\end{aligned}$$

Ralph travels with an average speed of  $5 \text{ m s}^{-1}$ .

- After three laps, Ralph is in exactly the same place as he started, so his displacement is zero. No matter how long he took to run these laps, his average velocity would still be zero, as  $v_{\text{av}} = \frac{\Delta x}{\Delta t}$ .
- Ralph's velocity is a constant  $5 \text{ m s}^{-1}$  as he travels around the circle. At the instant in question, the magnitude of his instantaneous velocity is also  $5 \text{ m s}^{-1}$ . This means Ralph's velocity is  $5 \text{ m s}^{-1}$  north.

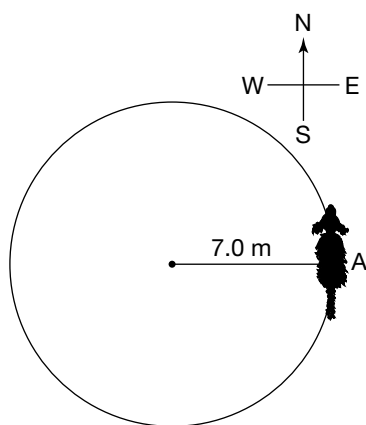

#### study on

Unit 3

**Uniform circular motion**

AOS 3

Summary screen and practice questions

Topic 4

Concept 1

#### study on

Unit 3



AOS 3

**See more**  
Uniform circular motion

Topic 4

Concept 1

### Revision question 1.10

A battery operated toy car completes a single lap of a circular track in 15 s with an average speed of  $1.3 \text{ m s}^{-1}$ . Assume that the speed of the toy car is constant.

- What is the radius of the track?
- What is the magnitude of the toy car's instantaneous velocity halfway through the lap?
- What is the average velocity of the toy car after half of the lap has been completed?
- What is the average velocity of the toy car over the entire lap?

## Changing velocities and accelerations

Any object moving in a circle has a continually changing velocity. Remember that although the magnitude of the velocity is constant, the direction is changing. As all objects with changing velocities are experiencing an acceleration, this means all objects that are moving in a circle are accelerating.

An acceleration can be caused only by an unbalanced force, so non-zero net force is needed to move an object in a circle. For example, a hammer thrower must apply a force to the hammer to keep it moving in a circle. When the hammer is released, it moves off with the velocity it had at the instant of release. The net force on the hammer is the gravitational force on it (neglecting the small amount of air resistance), and the hammer will experience projectile motion.

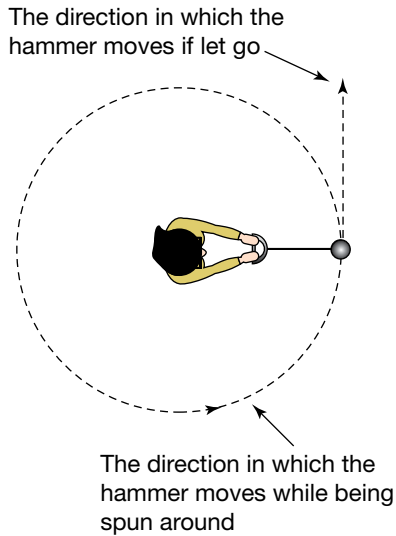

As long as the thrower keeps turning, the hammer moves in a circle. When the hammer is released, it moves in a straight line.



The hammer is always accelerating while it moves in a circle.

### In which direction is the force?

The figure at left shows diagrammatically the head of the hammer moving in a circle at two different times. It takes  $t$  seconds to move from A to B. To determine the acceleration, the change in velocity between these two points must be determined. Vector addition must be used to do this.

$$\Delta v = v_2 - v_1$$

$$\Delta v = v_2 + (-v_1)$$

Notice that when the  $\Delta v$  vector is transferred back to the original circle halfway between the two points in time, it is pointing towards the centre of the circle. (See the figure below.) (Such calculations become more accurate when very small time intervals are used; however, a large time interval has been used here to make the diagram clear.)

As  $a = \frac{\Delta v}{t}$ , the acceleration vector is in the same direction as  $\Delta v$ , but has a different magnitude and different units.

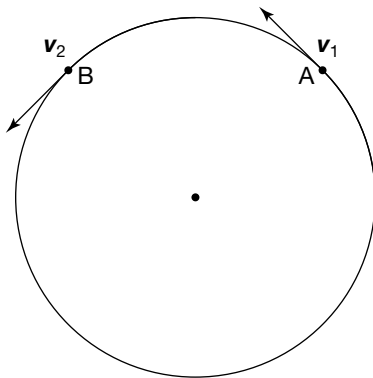

Velocity vectors for a hammer moving in an anticlockwise circle

(a)

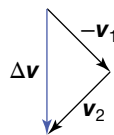

(b)

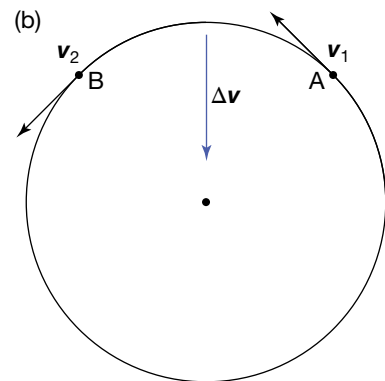

(a) Vector addition (b) The change in velocity is towards the centre of the circle.

No matter which time interval is chosen, the acceleration vector always points towards the centre of the circle. So, in order for an object to have

**Centripetal acceleration** is the centre-directed acceleration of an object moving in a circle.

uniform circular motion, the acceleration of the object *must be towards the centre* of the circle. Such an acceleration is called **centripetal acceleration**. The word *centripetal* literally means 'centre-seeking'. As stated in Newton's Second Law of Motion, the net force on an object is in the same direction as the acceleration ( $F_{\text{net}} = ma$ ). Therefore, the net force on an object moving with uniform circular motion is towards the centre of the circle.

Remember that while the hammer thrower is exerting a force on the hammer head towards the centre of the circle, the hammer head must be exerting an equal and opposite force on the thrower away from the centre of the circle (according to Newton's Third Law of Motion).

## Calculating accelerations and forces

Using vector diagrams and the formulae  $a = \frac{\Delta v}{t}$  and  $F_{\text{net}} = ma$ , it is possible to calculate the accelerations and forces involved in circular motion. However, doing calculations this way is tedious, and results can be inaccurate if the vector diagrams are not drawn carefully. It is much simpler to have a formula that will avoid these difficulties. The derivation of such a formula is a little challenging, but it is worth the effort!

By re-examining the two previous figures (see p. 30), it is possible to see that they both 'contain' isosceles triangles. These are shown at left.

Figure (a) is a diagram showing distances. It has the radius of the circle marked in twice. These radii form two sides of an isosceles triangle. The third side is formed by a line, or chord, joining point A with point B. It is the distance between the two points. When the angle  $\theta$  is very small, the length of the chord is virtually the same as the length of the arc which also joins these two points. As this is a distance, its length can be calculated using  $s = vt$ .

Figure (b) is a diagram showing velocities. As the object was moving with *uniform* circular motion, the length of the vectors  $v_2$  and  $-v_1$  are identical and form two sides of an isosceles triangle. As both parts of the figure at left are derived from the bottom figure on page 30, both of the angles marked as  $\theta$  are the same size. Therefore, the triangles are both isosceles triangles, containing the same angle,  $\theta$ . This means they are similar triangles — they can be thought of as the same triangle drawn on two different scales. The figure below left shows these triangles redrawn to make this more obvious.

As the triangles are similar, the ratio of their sides must be constant, so:

$$\frac{\Delta v}{vt} = \frac{v}{r}.$$

Multiplying both sides by  $v$ :

$$\frac{\Delta v}{t} = \frac{v^2}{r}.$$

$$\text{As } a = \frac{\Delta v}{t}:$$

$$\Rightarrow a = \frac{v^2}{r}.$$

This formula provides a way of calculating the centripetal acceleration of a mass moving with uniform circular motion having speed  $v$  and radius  $r$ .

If the acceleration of a known mass moving in a circle with constant speed has been calculated, the net force can be determined by applying  $F_{\text{net}} = ma$ .

The magnitude of the net force can also be calculated using:

$$F_{\text{net}} = ma = \frac{mv^2}{r}.$$

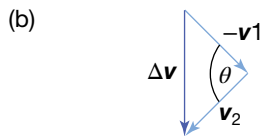
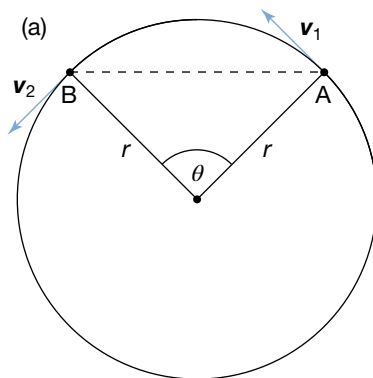

The triangles shown in parts (a) and (b) are both isosceles triangles.

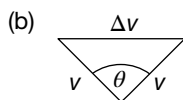
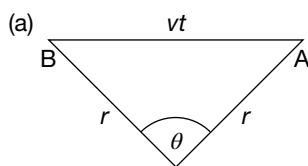

The two triangles are similar triangles.

### Sample problem 1.11

A car is driven around a roundabout at a constant speed of  $20 \text{ km h}^{-1}$  ( $5.6 \text{ m s}^{-1}$ ). The roundabout has a radius of  $3.5 \text{ m}$  and the car has a mass of  $1200 \text{ kg}$ .

- (a) What is the magnitude and direction of the acceleration of the car?  
(b) What is the magnitude and direction of the force on the car?

**Solution:** (a)  $v = 5.6 \text{ m s}^{-1}$ ,  $r = 3.5 \text{ m}$ ,  $a = ?$

$$\begin{aligned} a &= \frac{v^2}{r} \\ &= \frac{(5.6 \text{ m s}^{-1})^2}{3.5 \text{ m}} \\ &= 9.0 \text{ m s}^{-2} \end{aligned}$$

The car accelerates at  $9.0 \text{ m s}^{-2}$  towards the centre of the roundabout.

- (b) There are two different formulae that can be used to calculate this answer.

- (i) Use the answer to (a) and substitute into  $F_{\text{net}} = ma$ .

$$a = 9.0 \text{ m s}^{-2}, m = 1200 \text{ kg}, F_{\text{net}} = ?$$

$$\begin{aligned} F_{\text{net}} &= ma \\ &= 1200 \text{ kg} \times 9.0 \text{ m s}^{-2} \\ &= 1.1 \times 10^4 \text{ N} \end{aligned}$$

- (ii) Use the formula  $F_{\text{net}} = \frac{mv^2}{r}$ .

$$v = 5.6 \text{ m s}^{-1}, r = 3.5 \text{ m}, m = 1200 \text{ kg}, F_{\text{net}} = ?$$

$$\begin{aligned} F_{\text{net}} &= \frac{mv^2}{r} \\ &= \frac{1200 \text{ kg} (5.6 \text{ m s}^{-1})^2}{3.5 \text{ m}} \\ &= 1.1 \times 10^4 \text{ N} \end{aligned}$$

Both methods give the force on the car as  $1.1 \times 10^4 \text{ N}$  towards the centre of the roundabout.

Sometimes it is not easy to measure the velocity of the object undergoing circular motion. However, this can be calculated from the radius of the circle and the time taken to complete one circuit using the equation

$$\begin{aligned} v &= \frac{2\pi r}{T} \\ a &= \frac{v^2}{r} \\ \Rightarrow a &= \frac{\left(\frac{2\pi r}{T}\right)^2}{r} \\ a &= \frac{4\pi^2 r}{T^2} \end{aligned}$$

Substituting this into  $F_{\text{net}} = ma$ :

$$F_{\text{net}} = \frac{m4\pi^2 r}{T^2}.$$

### Revision question 1.11

Kwong (mass 60 kg) rides the Gravitron at the amusement park. This ride moves Kwong in a circle of radius 3.5 m, at a rate of one rotation every 2.5 s.

- (a) What is Kwong's acceleration?
- (b) What is the net force acting on Kwong? (Include a magnitude and a direction in your answer.)
- (c) Draw a labelled diagram showing all the forces acting on Kwong.

## Examples of forces that produce centripetal acceleration

Whenever an object is in uniform circular motion, the net force on that object must be towards the centre of the circle. Some examples of common situations involving forces producing centripetal acceleration follow.

### Tension

In physics, *tension* is used to describe the force applied by an object that is being pulled or stretched.

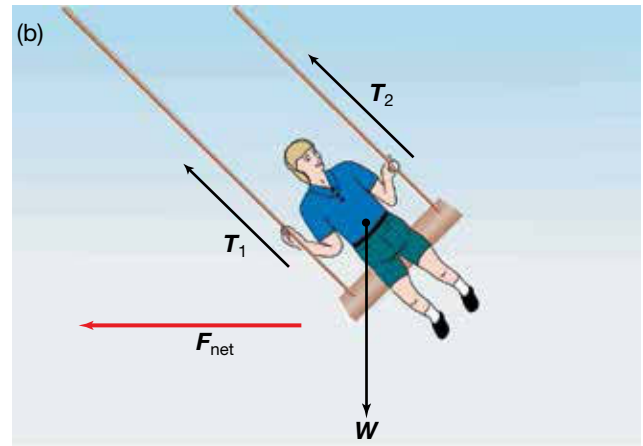

(a) Tension contributes to the net force in many amusement park rides. (b) The net force acting on a compartment in the ride

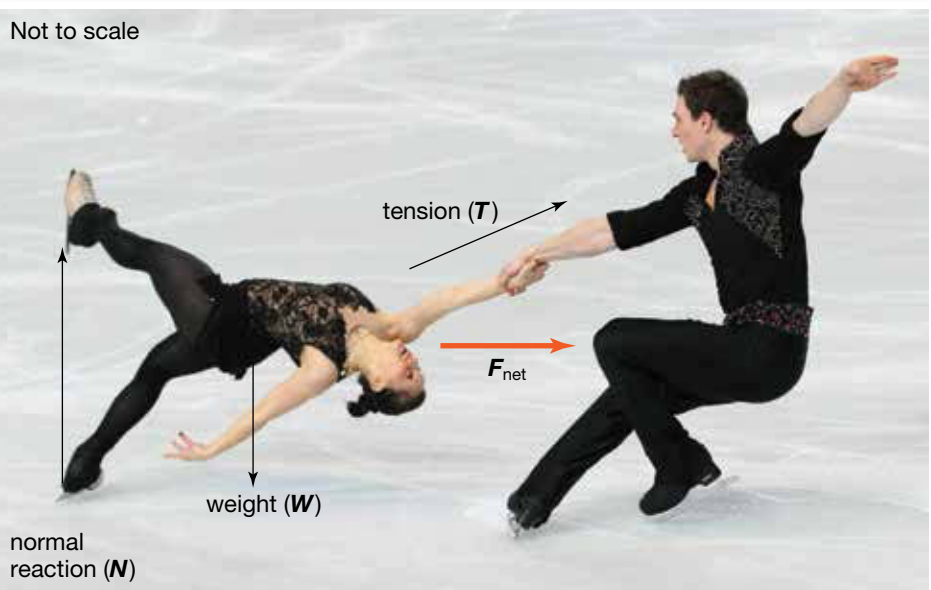

A component of the tension is the net force acting on the female skater when she is performing a 'death roll'.

## Friction

When a car rounds a corner, the sideways frictional forces contribute to the net force. The forwards frictional forces by the ground on the tyres keep the car moving, but if the sideways frictional forces are not sufficient, the net force on the car will not be towards the centre of the curve. In this situation, the net force is less than the force required to keep the car moving in a circle at this radius, and the car will not make it around the corner!

The formula  $F_{\text{net}} = \frac{mv^2}{r}$  shows that as the velocity increases, the force needed to move in a circle greatly increases ( $F_{\text{net}} \propto v^2$ ). This is why it is vital that cars do not attempt to corner while travelling too fast.

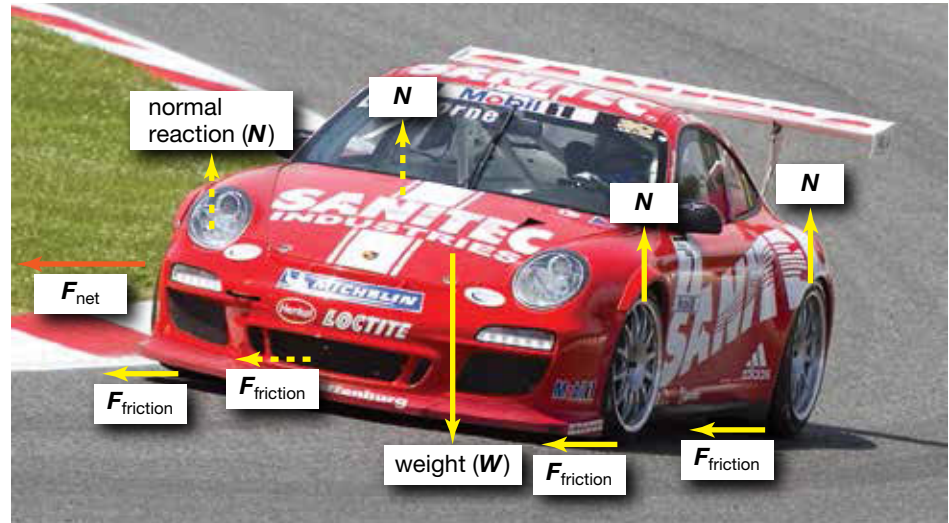

The sideways frictional forces of the ground on the tyres enable a car to move around a corner.

Track athletes, cyclists and motorcyclists also rely on sideways frictional forces to enable them to move around corners. To increase the size of the sideways frictional force, which will therefore allow them to corner more quickly, they often lean into the corner. The lean also means that they are pushing on the surface at an angle, so the reaction force is no longer normal to the ground. It has a component towards the centre of their circular motion.

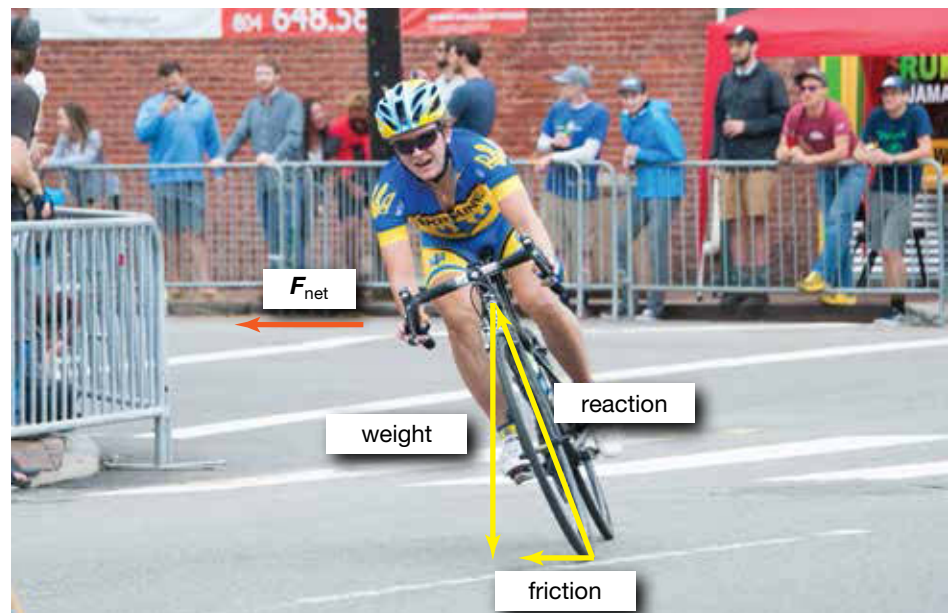

Leaning into a corner increases the size of the net force, allowing a higher speed while cornering. The sideways friction is greater, and the reaction force of the ground has a component towards the centre of the circular motion.



In velodromes, the track is banked so that a component of the normal reaction acts towards the centre of the velodrome, thus increasing the net force in this direction. As the centripetal force is larger, the cyclists can move around the corners faster than if they had to rely on friction alone.

### Going around the bend

When a vehicle travels around a bend, or curve, at constant speed, its motion can be considered to be part of a circular motion. The curve makes up the arc of a circle. In order for a car to travel around a corner safely, the net force acting on it must be towards the centre of the circle.

Part (a) of the next figure shows the forces acting on a vehicle of mass  $m$  travelling around a curve with a radius,  $r$ , at a constant speed,  $v$ . The forces acting on the car are weight,  $W$ , friction and the normal reaction,  $N$ .

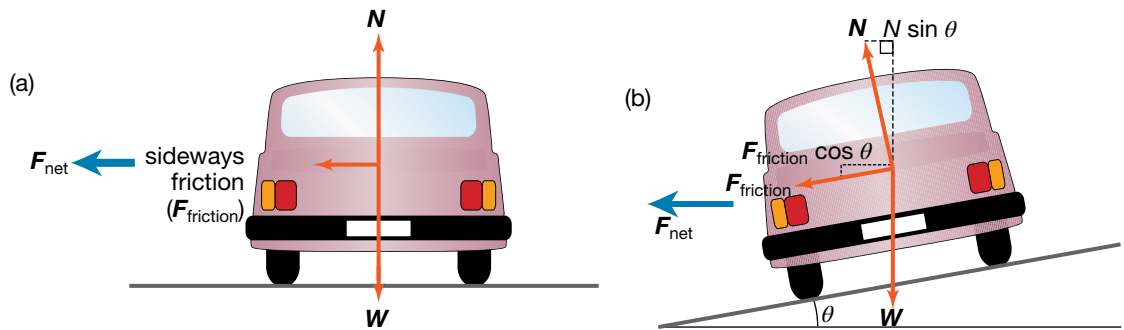

(a) For the vehicle to take the corner safely, the net force must be towards the centre of the circle. (b) Banking the road allows a component of the normal reaction to contribute to the centripetal force.

On a level road the only force with a component towards the centre of the circle is the 'sideways' friction. This sideways friction makes up the whole of the magnitude of the net force on the vehicle. That is:

$$F_{\text{net}} = \text{sideways friction} \\ = \frac{mv^2}{r}.$$

If you drive the vehicle around the curve with a speed so that  $\frac{mv^2}{r}$  is greater than the sideways friction, the motion is no longer circular and the vehicle will skid off the road. If the road is wet, sideways friction is less and a lower speed is necessary to drive safely around the curve.

If the road is banked at an angle  $\theta$  towards the centre of the circle, a component of the normal reaction  $N \sin \theta$  can also contribute to the net force. This is shown in diagram (b) above.

$$F_{\text{net}} = F_{\text{friction}} \cos \theta + N \sin \theta$$

The larger net force means that, for a given curve, banking the road makes a higher speed possible.

Loose gravel on bends in roads is dangerous because it reduces the sideways friction force. At low speeds this is not a problem, but a vehicle travelling at high speed is likely to lose control and run off the road in a straight line.

### Sample problem 1.12

A car of mass 1280 kg travels around a bend with a radius of 12.0 m. The total sideways friction on the wheels is 16 400 N. The road is not banked. Calculate the maximum constant speed at which the car can be driven around the bend without skidding off the road.

**Solution:** The car will maintain the circular motion around the bend if:

$$F_{\text{net}} = \frac{mv^2}{r}$$

where

$v$  = maximum speed.

If  $v$  were to exceed this speed,  $F_{\text{net}} < \frac{mv^2}{r}$ , the circular motion could not be maintained and the vehicle would skid.

$$\begin{aligned} F_{\text{net}} &= \text{sideways friction} = 16\,400 \text{ N} = 1280 \text{ kg} \times \frac{v^2}{12.0 \text{ m}} \\ \Rightarrow v^2 &= 16\,400 \text{ N} \times \frac{12.0 \text{ m}}{1280 \text{ kg}} \\ &= 153.75 \text{ m}^2 \text{ s}^{-2} \\ v &= 12.4 \text{ m s}^{-1} \end{aligned}$$

The maximum constant speed at which the vehicle can be driven around the bend is  $12.4 \text{ m s}^{-1}$ .

### Revision question 1.12

Calculate the maximum constant speed of the car in sample problem 1.12 (without skidding off the road) if the road is banked at an angle of  $10^\circ$  to the horizontal.

## Inside circular motion

What happens to people and objects inside larger objects which are travelling in circles? The answer to this question depends on several factors.

Let's think about passengers inside a bus. The sideways frictional forces by the road on the bus tyres act towards the centre of the circle, which increases the net force on the bus and keeps the bus moving around the circle. If the passengers are also to move in a circle (therefore keeping the same position in the bus) they need, too, to have a net force towards the centre of the circle. Without such a force, they would continue to move in a straight line and probably hit the side of the bus! Usually the friction between the seat and a passenger's legs is sufficient to prevent this happening.

However, if the bus is moving quickly, friction alone may not be adequate. In such cases, passengers may grab hold of the seat in front, thus adding a force of tension through their arms. Hopefully, the sum of the frictional force of the seat on a passenger's legs and the horizontal component of tensile force through the passenger's arms will provide a large enough centripetal force to keep that person moving in the same circle as the bus!

### Sample problem 1.13

When travelling around a roundabout, John notices that the fluffy dice suspended from his rear-vision mirror swing out. If John is travelling at  $8.0 \text{ m s}^{-1}$  and the roundabout has a radius of 5.0 m, what angle will the string connected to the fluffy dice (mass 100 g) make with the vertical?

**Solution:** When John enters the roundabout, the dice, which are hanging straight down, will begin to move outwards. As long as John maintains a constant speed, they

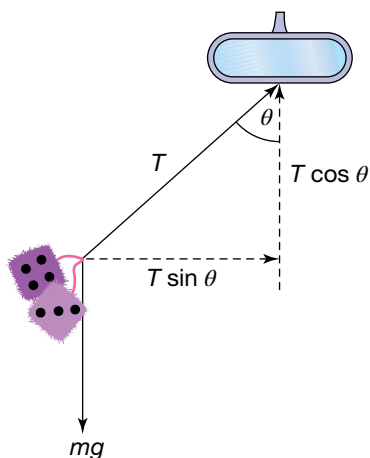

will reach a point at which they become stationary at some angle to the vertical. At this point, the net force on the dice is the centripetal force. Because the dice appear stationary to John, they must be moving in the same circle, with the same speed, as John and his car.

$$v = 8.0 \text{ m s}^{-1}, r = 5.0 \text{ m}, m = 0.100 \text{ kg}$$

Consider the vertical components of the forces.

The acceleration has no vertical component.

$$\Rightarrow mg = T \cos \theta$$

$$\Rightarrow T = \frac{mg}{\cos \theta} \quad (1)$$

Consider the horizontal components of the forces.

$$F_{\text{net}} = \frac{mv^2}{r} = T \sin \theta$$

$$\Rightarrow \frac{mv^2}{r} = T \sin \theta \quad (2)$$

To solve the simultaneous equations, substitute for  $T$  (from equation (1)) into equation (2).

$$\frac{mv^2}{r} = \frac{mg}{\cos \theta} \times \sin \theta$$

$$\Rightarrow \frac{mv^2}{r} = mg \tan \theta$$

$$\Rightarrow \frac{v^2}{rg} = \tan \theta$$

$$\Rightarrow \frac{(8.0 \text{ m s}^{-1})^2}{5.0 \text{ m} \times 9.8 \text{ N kg}^{-1}} = \tan \theta$$

$$\Rightarrow \theta = 53^\circ$$

### Revision question 1.13

A 50 kg circus performer grips a vertical rope with her teeth and sets herself moving in a circle with a radius of 5.0 m at a constant horizontal speed of  $3.0 \text{ m s}^{-1}$ .

- What angle does the rope make the vertical?
- What is the magnitude of the tension in the rope?

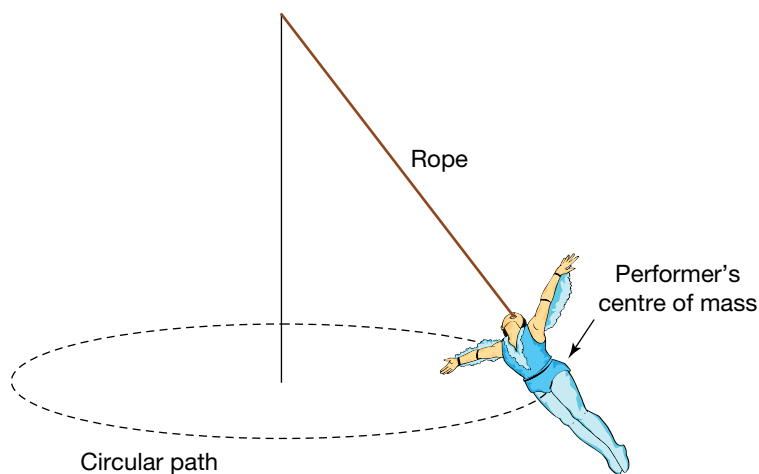

## Non-uniform circular motion

So far, we have considered only what happens when the circular motion is carried out at a constant speed. However, in many situations this is not the case. When the circle is vertical, the effects of gravity can cause the object to go slower at the top of the circle than at the bottom. Such situations can be examined either by analysing the energy transformations that take place or by applying Newton's laws of motion.

When a skateboarder enters a half-pipe from the top, that person has a certain amount of potential energy, but a velocity close to zero. At the bottom of the half-pipe, some of the gravitational potential energy of the skateboarder has been transformed into kinetic energy. As long as the person's change in height is known, it is possible to calculate the speed at that point.

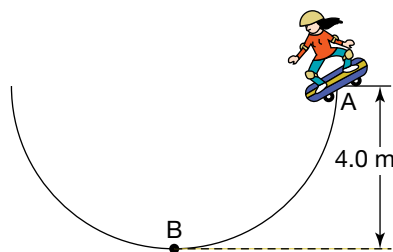

**Solution:**

### Sample problem 1.14

A skateboarder (mass 60 kg) enters the half-pipe at point A, as shown in the figure at left. (Assume the frictional forces are negligible.)

- What is the skateboarder's speed at point B?
- What is the net force on the skateboarder at B?
- What is the normal reaction force on the skateboarder at B?

(a) At point A the skateboarder has potential energy, but no kinetic energy. At point B, all the potential energy has been converted to kinetic energy. Once the kinetic energy is known, it is easy to calculate the velocity of the skateboarder.

$$m = 60 \text{ kg}, \Delta h = 4.0 \text{ m}, g = 9.8 \text{ m s}^{-2}$$

decrease of potential energy from A to B = increase of kinetic energy from A to B

$$-(PE_B - PE_A) = KE_B - KE_A$$

$$-(mgh_B - mgh_A) = \frac{1}{2}mv_B^2 - 0$$

$$-mg(h_B - h_A) = \frac{1}{2}mv^2$$

Cancelling  $m$  from both sides:

$$-g(h_B - h_A) = \frac{1}{2}v^2$$

$$-9.8(0 \text{ m} - 4.0 \text{ m}) = \frac{1}{2}v^2$$

$$v^2 = 78.4 \text{ m}^2 \text{ s}^{-2}$$

$$v = 8.854 \text{ m s}^{-1}, \text{ rounded to } 8.9 \text{ m s}^{-1}.$$

The skateboarder's speed at B is  $8.9 \text{ m s}^{-1}$ .

- (b) The formula  $F_{\text{net}} = \frac{mv^2}{r}$  can still be used for any point of the centripetal motion. It must be remembered, however, that the force will be different at each point as the velocity is constantly changing.

$$m = 60 \text{ kg}, r = 4.0 \text{ m}, v = 8.9 \text{ m s}^{-1}$$

$$\begin{aligned} F_{\text{net}} &= \frac{mv^2}{r} \\ &= \frac{60 \text{ kg} \times (8.854 \text{ m s}^{-1})^2}{4.0 \text{ m}} \\ &= 1176 \text{ N}, \text{ rounded to } 1200 \text{ N} \end{aligned}$$

The net force acting on the skateboarder at point B is 1200 N upwards.

### study on

Unit 3

**Motion in a horizontal plane**

AOS 3

Summary screen and practice questions

Topic 4

Concept 2

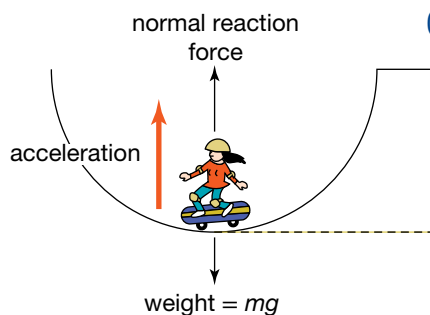

Forces acting on the skateboarder

(c) As there is more than one force acting on the skateboarder, it helps to draw a diagram. (See the figure at left.)

$$F_{\text{net}} = N \text{ (normal reaction force)} + W \text{ (weight) (when forces are written as vectors)}$$

$$F_{\text{net}} = N - W \text{ (when direction is taken into account using sign)}$$

$$\begin{aligned} N &= F_{\text{net}} + mg \\ &= 1200 \text{ N} + 60 \text{ kg} \times 9.8 \text{ m s}^{-2} \\ &= 1788 \text{ N, rounded to } 1800 \text{ N} \end{aligned}$$

The normal reaction force acting on the skateboarder at point B is 1800 N upwards. This is larger than the normal reaction force if the skateboarder were stationary. This causes the skateboarder to experience a sensation of heaviness.

### Revision question 1.14

A roller-coaster car travels through the bottom of a dip of radius 9.0 m at a speed of  $13 \text{ m s}^{-1}$ .

- What is the net force on a passenger of mass 60 kg?
- What is the normal reaction force on the passenger by the seat?
- Compare the size of the reaction force to the weight force.

## Amusement park physics

The experience of heaviness described in the previous section, when the reaction force is greater than the weight force, occurs on a roller coaster when the roller-coaster car travels through a dip at the bottom of a vertical arc. When the car is at the top of a vertical arc, the passengers experience a feeling of being lighter. How can this be explained?

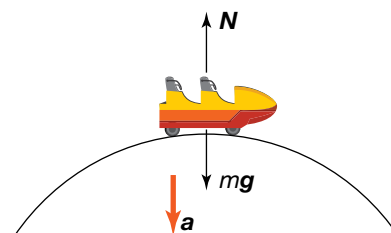

When the roller-coaster car is on the top of the track, the reaction force is upwards, and the weight force and the net force are downwards. So,

$$F_{\text{net}} = ma = mg - N.$$

For circular motion, the acceleration is centripetal and is given by the expression  $\frac{v^2}{r}$ :

$$\frac{mv^2}{r} = mg - N$$

### Sample problem 1.15

A passenger is in a roller-coaster car at the top of a circular arc of radius 9.0 m.

- At what speed would the reaction force on the passenger equal half their weight force?
- What happens to the reaction force as the speed increases?
- What would the passenger experience?

**Solution:** (a) Let  $N = \frac{mg}{2}$ ,  $r = 9.0$  m.

$$\text{Using } \frac{mv^2}{r} = mg - N,$$

$$\frac{mv^2}{r} = mg - \frac{mg}{2}$$

$$\frac{v^2}{r} = \frac{g}{2}$$

$$v = \sqrt{\frac{gr}{2}}$$

$$= \sqrt{\frac{9.8 \times 9.0}{2}}$$

$$= 6.6 \text{ m s}^{-1}$$

(b) Rearranging  $\frac{mv^2}{r} = mg - N$  gives  $N = mg - \frac{mv^2}{r}$ .

The weight force,  $mg$ , is constant, so as the speed,  $v$ , increases, the reaction force,  $N$ , gets smaller.

(c) The reaction force is less than the weight force, so the passenger will feel lighter.

The reaction force is a push by the track on the wheels of the roller-coaster car. The track can only push up on the wheels; it cannot pull down on the wheels to provide a downwards force. So as the speed increases, there is a limit on how small the reaction force can be. That smallest value is zero. What would the passenger feel? And what is happening to the roller-coaster car?

When the reaction force is zero, the passenger will feel as if they are floating just above the seat. They will feel no compression in the bones of their backside. For the car, at this point it has lost contact with the track. Any attempt to put on the brakes will not slow down the car, as the frictional contact with the track depends on the size of the reaction force. No reaction force means no friction.

Modern roller-coaster cars have two sets of wheels, one set above the track and one set below the track, so that if the car is moving too fast, the track can supply a downward reaction force on the lower set of wheels.

The safety features of roller coasters cannot be applied to cars on the road. If a car goes too fast over a hump on the road, the situation is potentially very dangerous. Loss of contact with the road means that turning the steering wheel to avoid an obstacle or an oncoming car will have no effect whatsoever. The car will continue on in the same direction.

### Revision question 1.15

- (a) A car of mass 800 kg slows down to a speed of  $4.0 \text{ m s}^{-1}$  to travel over a speed hump that forms the arc of a circle of radius 2.4 m. What normal reaction force acts on the car at the top of the speed hump?
- (b) At what minimum speed would a car of mass 1000 kg have to travel to momentarily leave the road at the top of the speed hump described in part (a)? (To leave the road the normal reaction would have to have decreased to zero.)

# Chapter review



## Summary

- Motion can be described in terms of distance, displacement, speed, velocity, acceleration and time.
- Distance is a measure of the length of the path taken when an object changes position.
- Displacement is a measure of the change in position of an object.
- Speed is a measure of the rate at which an object moves over a distance.

$$\text{average speed} = \frac{\text{distance travelled}}{\text{time interval}}$$

- Velocity is a measure of the rate of displacement, or the rate of changing position.

$$\mathbf{v}_{\text{av}} = \frac{\Delta \mathbf{x}}{\Delta t}$$

- Acceleration is the rate of change of velocity.

$$\mathbf{a}_{\text{av}} = \frac{\Delta \mathbf{v}}{\Delta t}$$

- Displacement, velocity and acceleration are vector quantities.
- Instantaneous speed is the speed at a particular instant of time. Instantaneous velocity is the velocity at a particular instant of time.
- The velocity (or speed) of an object at an instant is equal to the gradient of the graph of position versus time (or distance versus time) for that instant.
- The acceleration of an object at an instant is equal to the gradient of the graph of velocity versus time for that instant.
- The displacement of an object during a time interval is equal to the area under the velocity–time graph representing the time interval.
- The change in velocity of an object during a time interval is equal to the area under the acceleration–time graph representing the time interval.
- The motion of an object moving in a straight line can be described algebraically using several formulae including:

$$v = u + at$$

$$s = \frac{1}{2}(u + v)t$$

$$s = ut + \frac{1}{2}at^2$$

$$s = vt - \frac{1}{2}at^2$$

$$v^2 = u^2 + 2as.$$

- Newton's three laws of motion can be applied to explain, predict or analyse situations in which one or more forces act on an object or system of objects.
  - Newton's First Law of Motion states that every object continues in its state of rest or uniform motion unless made to change by a non-zero net force.
  - Newton's second Law of Motion can be expressed algebraically as

$$\mathbf{F}_{\text{net}} = m\mathbf{a} \text{ or } \mathbf{F}_{\text{net}} = \frac{\Delta \mathbf{p}}{\Delta t}.$$

- Newton's Third Law of Motion states that whenever an object applies a force to a second object, the second object applies an equal and opposite force to the first object.

$$\mathbf{F}_{\text{on A by B}} = -\mathbf{F}_{\text{on B by A}}.$$

- The forces acting on a moving vehicle include weight, normal reaction, driving force and resistive forces including air resistance and road friction. The motion of the car depends on the net force acting on the vehicle.
- For a vehicle on a slope, analysis of forces acting on, and motion of, the vehicle can be undertaken by resolving the forces into two components — one parallel to the slope and one perpendicular to the slope.
- Momentum is the product of the mass of an object and its velocity. Momentum is a vector quantity.
- There are two forces acting on a projectile in flight: gravity acting downwards and air resistance acting in the opposite direction to that of the motion. In modelling projectile motion, it is helpful to ignore the air resistance.
- To analyse the motion of a projectile, the equations of motion with constant acceleration can be applied to the horizontal and vertical components of the motion separately.
- An object projected horizontally near Earth's surface travels in a parabolic path if air resistance is negligible.
- The average speed and velocity of an object moving in a circle is quite different from its instantaneous speed and velocity. The speed  $v$  of an object moving at constant speed in a circle of radius  $r$  is given by the equation  $v = \frac{2\pi r}{T}$  where  $T$  is the period of the circular motion.
- The acceleration of an object in uniform circular motion is always directed towards the centre of the circle. It is called centripetal acceleration.

- The magnitude of the acceleration  $a$  of an object in uniform circular motion can be calculated using the equations:

$$a = \frac{v^2}{r} \quad \text{or} \quad a = \frac{4\pi^2 r}{T^2}$$

- The net force on an object in uniform circular motion is always towards the centre of the circle.

## Questions

In answering the questions on the following pages, assume, where relevant, that the magnitude of the gravitational field at Earth's surface is  $9.8 \text{ N kg}^{-1}$ .

### Describing and analysing motion

- Two physics students are trying to determine the instantaneous speed of a bicycle 5.0 m from the start of a 1000 m sprint. They use a stopwatch to measure the time taken for the bicycle to cover the first 10 m. If the acceleration was constant, and the measured time was 4.0 s, what was the instantaneous speed of the bicycle at the 5.0 m mark?
- When a netball is thrown straight up on a still day, what is its acceleration at the very top of its flight?
- A car travelling north at a speed of  $40 \text{ km h}^{-1}$  turns right to head due east at a speed of  $30 \text{ km h}^{-1}$ . This change in direction and speed takes 2.0 s. Calculate the average acceleration of the car in:
  - $\text{km h}^{-1} \text{ s}^{-1}$
  - $\text{m s}^{-2}$ .

### Newton's laws of motion

- When a stationary car is hit from behind by another vehicle at moderate speed, headrests behind the occupants reduce the likelihood of injury. Explain in terms of Newton's laws how they do this.
- It is often said that seatbelts prevent a passenger from being thrown forward in a car collision. What is wrong with such a statement?
- Draw a sketch showing all of the forces acting on a tennis ball while it is:
  - falling to the ground
  - in contact with the ground just before rebounding upwards
  - on its upward path after bouncing on the ground.

The length of the arrows representing the forces should give a rough indication of relative size.
- A coin is allowed to slide with a constant velocity down an inclined plane as shown. Which of the arrows A to G on the diagram represents the direction of each of the following? If none of the directions is correct, write X.
  - The weight of the coin
  - The normal reaction
  - The net force

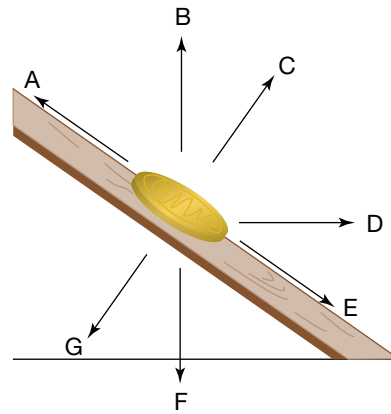

- A child pulls a 4.0 kg toy cart along a horizontal path with a rope so that the rope makes an angle of  $30^\circ$  with the horizontal. The tension in the rope is 12 N.
  - What is the weight of the toy cart?
  - What is the component of tension in the direction of motion?
  - What is the magnitude of the normal reaction?
- What is the matching 'reaction' to the gravitational pull of Earth on you?

### Applying Newton's Second Law of Motion

- A dodgem car of mass 200 kg is driven due south into a rigid barrier at an initial speed of  $5.0 \text{ m s}^{-1}$ . The dodgem rebounds at a speed of  $2.0 \text{ m s}^{-1}$ . It is in contact with the barrier for 0.20 s. Calculate:
  - the average acceleration of the car during its interaction with the barrier
  - the average net force applied to the car during its interaction with the barrier.
- The graph below describes the motion of a 40 t ( $4.0 \times 10^4 \text{ kg}$ ) train as it travels between two neighbouring railway stations. The total friction force resisting the motion of the train while the brakes are not applied is 8000 N. The brakes are not applied until the final 20 s of the journey.

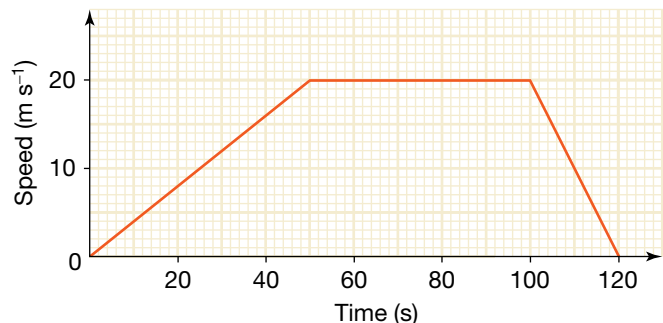

- What is the braking distance of the train?
- A cyclist travels between the stations at a constant speed, leaving the first station and arriving at the second station at the same time as the train. What is the constant speed of the cyclist?



- (c) What forward force is applied to the train by the tracks while it is accelerating?  
 (d) What additional frictional force is applied to the train while it is braking?
- 12.** A 1500 kg car is resting on a slope inclined at  $20^\circ$  to the horizontal. It has been left out of gear, so the only reason that it doesn't roll down the hill is that the handbrake is on.  
 (a) Draw a labelled diagram showing the forces acting on the car.  
 (b) Calculate the magnitude of the normal reaction force.  
 (c) What is the net force acting on the car?  
 (d) What is the magnitude of the frictional force acting on the car?
- 13.** An experienced downhill skier with a mass of 60 kg (including skis) moves in a straight line down a slope inclined at  $30^\circ$  to the horizontal with a constant speed of  $15 \text{ m s}^{-1}$ .  
 (a) What is the direction of the net force acting on the skier?  
 (b) What is the magnitude of the sum of the air resistance and frictional forces opposing the skier's motion?
- 14.** A waterskier of mass 70 kg is towed in a northerly direction by a speedboat with a mass of 350 kg. The frictional forces opposing the forward motion of the waterskier total 240 N.  
 (a) If the waterskier has an acceleration of  $2.0 \text{ m s}^{-2}$  due north, what is the tension in the rope towing the waterskier?  
 (b) If the frictional forces opposing the forward motion of the speedboat total 600 N, what is the thrust force applied to the boat due to the action of the motor?
- 15.** A 4.0 kg magpie flies towards a very tight plastic wire on a clothes line. The wire is perfectly horizontal and is stretched between poles 4.0 m apart. The magpie lands on the centre of the wire, depressing it by a vertical distance of 4.0 cm. What is the magnitude of the tension in the wire?
- 16.** An old light globe hangs by a wire from the roof of a train. What angle does the globe make with the vertical when the train is accelerating at  $1.5 \text{ m s}^{-2}$ ?

### Projectile motion

- 17.** A ball has been thrown directly upwards. Draw the ball at three points during its flight (going up, at the top and going down) and mark on the diagrams all the forces acting on the ball at each time.
- 18.** Describe the effects of air resistance on the motion of a basketball falling vertically from a height.
- 19.** Ignoring air resistance, the acceleration of a projectile in flight is always the same, whether it is going up or down. Use graphs of motion to show why this is the case.

- 20.** In each of the cases shown below, calculate the magnitude of the vertical and horizontal components of the velocity.

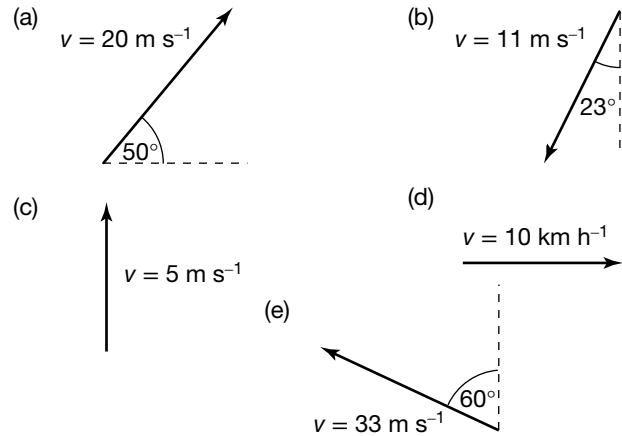

- 21.** Explain why the horizontal component of velocity remains the same when a projectile's motion is modelled.
- 22.** While many pieces of information relating to the vertical and horizontal parts of a particular projectile's motion are different, the time is always the same. Explain why this is so.
- 23.** A cube-shaped parcel of flour with a volume about the size of a refrigerator is dropped from a height of 500 m from a helicopter travelling horizontally at a speed of  $20 \text{ m s}^{-1}$ .  
 (a) Describe the effects of air resistance on:  
 (i) the horizontal component of the motion of the parcel  
 (ii) the vertical component of motion of the parcel.  
 (b) Which of the horizontal or vertical components of the motion of the parcel is likely to experience the greater air resistance during:  
 (i) the first 2 s of its fall  
 (ii) the final 2 s of its fall?  
 Give reasons for each answer.
- 24.** A ball falls from the roof-top tennis court of an inner city building. This tennis court is 150 m above the street below. (Assume the ball has no initial velocity and ignore air resistance.)  
 (a) How long would the ball take to hit the street?  
 (b) What would the vertical velocity of the ball be just prior to hitting the ground?
- 25.** After taking a catch, Ricky Ponting throws the cricket ball up into the air in jubilation.  
 (a) The vertical velocity of the ball as it leaves his hands is  $18 \text{ m s}^{-1}$ . How long will the ball take to return to its original position?  
 (b) What was the ball's maximum vertical displacement?

(c) Draw vectors to indicate the net force on the ball (ignoring air resistance)

(i) the instant it left Ponting's hands

(ii) at the top of its flight

(iii) as it returns to its original position.

26. The metal shell of a wrecked car (mass 500 kg) is dropped from a height of 10 m when the electromagnet holding it is turned off.
- What was the vertical component of the velocity of the car just before it hit the ground?
  - How long did the car take to fall?
  - If the electromagnet was moving horizontally at a constant speed of  $0.5 \text{ m s}^{-1}$  as it was turned off, how far (horizontally) did the car land from the point at which it was dropped?
  - What was the velocity of the car just before it hit the ground? Include a direction in your answer.
  - What was the magnitude and direction of the net force acting on the car:
    - while it was attached to the moving electromagnet
    - while it was falling?
27. A car is travelling along the freeway at a speed of  $100 \text{ km h}^{-1}$ . Seeing an accident ahead, the driver slams on the brakes. A tissue box flies forward from the back shelf.
- Explain, in terms of Newton's laws, why the tissue box continued to move when the car stopped.
  - What was the velocity of the tissue box as it left the shelf?
  - The tissue box flew through the interior of the car and hit the windscreen, a horizontal distance of 2.5 m from the back shelf. What vertical distance had the tissue box fallen in this time? State any assumptions that you have made in modelling the motion of the box.
  - Why is it important to secure all items when travelling in a car?
28. A friend wants to get into the *Guinness Book of Records* by jumping over 11 people on his push bike. He has set up two ramps as shown below, and has allowed a space of 0.5 m for each person to lay down in. In practice attempts, he has averaged a speed of  $7.0 \text{ m s}^{-1}$  at the end of the ramp. Will you lay down as the eleventh person between the ramps?

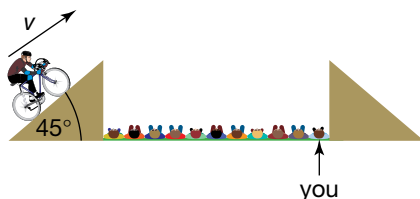

29. You have entered the javelin event in your school athletics competition. Not being a naturally talented thrower, you decide to use your brain to maximise your performance. Using your understanding of the principles of projectile motion, decide on the best angle to release your javelin. Back up your answer with calculations.
30. A skateboarder jumps a horizontal distance of 2 m, taking off at a speed of  $5 \text{ m s}^{-1}$ . The jump takes 0.42 s to complete.
- What was the skateboarder's initial horizontal velocity?
  - What was the angle of take-off?
  - What was the maximum height above the ground reached during the jump?
31. During practice, a young soccer player shoots for goal. The short goalkeeper is able to stop the ball only if it is more than 30 cm beneath the cross-bar. The ball is kicked at an angle of  $45^\circ$  and a speed of  $9.8 \text{ m s}^{-1}$ . The arrangement of the players is shown below.

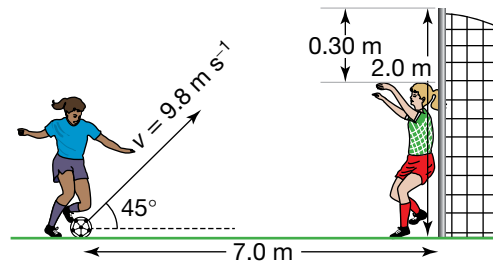

- How long does it take the ball to reach the top of its flight?
  - How far vertically and horizontally has the ball travelled at this time?
  - How long does it take the ball to reach the soccer net from the top of its flight?
  - Will the ball go into the soccer net, over it, or will the goalkeeper stop it?
32. A motocross rider rides over the jump shown below at a speed of  $50 \text{ km h}^{-1}$ .
- How long does it take the bike to reach the top of its flight?
  - How far vertically and horizontally has the bike travelled at this time?
  - How long does it take the bike to reach the ground from the top of its flight?
  - What is the total range of the jump?

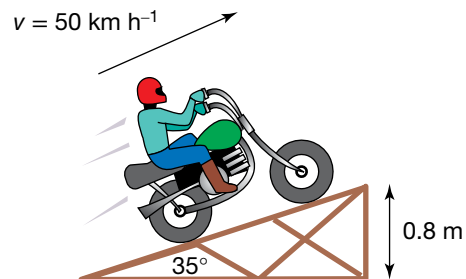

- 33.** A waterskier at the Moomba Masters competition in Melbourne leaves a ramp at a speed of  $50 \text{ km h}^{-1}$  and at an angle of  $30^\circ$ . The edge of the ramp is  $1.7 \text{ m}$  above the water. Calculate:
- the range of the jump
  - the velocity at which the jumper hits the water.
- (Hint: Split the waterskier's motion into two sections, before the highest point and after the highest point, to avoid solving a quadratic equation.)
- 34.** A gymnast wants to jump a distance of  $2.5 \text{ m}$ , leaving the ground at an angle of  $28^\circ$ . With what speed must the gymnast take off?
- 35.** A horse rider wants to jump a  $3.0 \text{ m}$  wide stream. The horse can approach the stream with a speed of  $7 \text{ m s}^{-1}$ . At what angle must the horse take off? (Hint: You will need to use trigonometric identities from mathematics, or model the situation using a spreadsheet to solve this problem.)

### Uniform circular motion

- 36.** A jogger, of mass  $65 \text{ kg}$ , runs around a circular track of radius  $120 \text{ m}$  with an average speed of  $6.0 \text{ km h}^{-1}$ .
- What is the centripetal acceleration of the jogger?
  - What is the net force acting on the jogger?
- 37.** At the school fete, Lucy and Natasha have a ride on the merry-go-round. The merry-go-round completes one turn every  $35 \text{ s}$ . Natasha's horse is  $2.5 \text{ m}$  from the centre of the ride, while Lucy's horse is a further  $70 \text{ cm}$  out. Which girl would experience the greatest centripetal acceleration? Support your answer with calculations.
- 38.** At a children's amusement park, the miniature train ride completes a circuit of radius  $350 \text{ m}$ , maintaining a constant speed of  $15 \text{ km h}^{-1}$ .
- What is the centripetal acceleration of the train?
  - What is the net force acting on a  $35 \text{ kg}$  child riding on the train?
  - What is the net force acting on the  $1500 \text{ kg}$  train?
  - Explain why the net forces acting on the child and the train are different and yet the train and the child are moving along the same path.
- 39.** The toy car in a slot car set runs on a circular track. The track has a radius of  $65 \text{ cm}$ , and the  $0.12 \text{ kg}$  car completes one circuit in  $5.2 \text{ s}$ .
- What is the centripetal acceleration of the car?
  - What is the net force acting on the car?
  - Draw a labelled diagram showing all the forces acting on the car. Also include the direction and magnitude of the net force on your diagram.
- 40.** When a mass moves in a circle, it is subject to a net force. This force acts at right angles to the direction of motion of the mass at any point in time. Use Newton's laws to explain why the mass does not need a propelling force to act in the direction of its motion.
- 41.** Explain why motorcyclists lean into bends.
- 42.** A rubber stopper of mass  $50.0 \text{ g}$  is whirled in a horizontal circle on the end of a  $1.50 \text{ m}$  length of string. The time taken for ten complete revolutions of the stopper is  $8.00 \text{ s}$ . The string makes an angle of  $6.03^\circ$  with the horizontal. Calculate:
- the speed of the stopper
  - the centripetal acceleration of the stopper
  - the net force acting on the stopper
  - the magnitude of the tension in the string.
- 43.** A ball is tied to the end of a string and whirled in a horizontal circle of radius  $2.0 \text{ m}$ . The string makes an angle of  $10^\circ$  with the horizontal. The tension in the string is  $12 \text{ N}$ .
- Calculate the magnitude of the centripetal force acting on the ball.
  - If the mass of the ball is  $200 \text{ g}$ , what is its speed?
  - What is the period of revolution of the ball?
- 44.** Carl is riding around a corner on his bike at a constant speed of  $15 \text{ km h}^{-1}$ . The corner approximates part of a circle of radius  $4.5 \text{ m}$ . The combined mass of Carl and his bike is  $90 \text{ kg}$ . Carl keeps the bike in a vertical plane.
- What is the net force acting on Carl and his bike?
  - What is the sideways frictional force acting on the tyres of the bike?
  - Carl rides onto a patch of oil on the road; the sideways frictional forces are now  $90\%$  of their original size. If Carl maintains a constant speed, what will happen to the radius of the circular path he is taking?
- 45.** A cyclist rounds a bend. The surface of the road is horizontal. The cyclist is forced to lean at an angle of  $20^\circ$  to the vertical to 'only just' take the bend successfully. The total sideways frictional force on the tyres is  $360 \text{ N}$ . The cycle has a mass of  $20 \text{ kg}$ . What is the mass of the cyclist?
- 46.** A road is to be banked so that any vehicle can take the bend at a speed of  $30 \text{ m s}^{-1}$  without having to rely on sideways friction. The radius of curvature of the road is  $12 \text{ m}$ . At what angle should it be banked?
- 47.** A car of mass  $800 \text{ kg}$  travels over the crest of a hill that forms the arc of a circle, as shown in the following figure.
- Draw a labelled diagram showing all the forces acting on the car.
  - The car travels just fast enough for the car to leave the ground momentarily at the crest of

the hill. This means the normal reaction force is zero at this point.

- (i) What is the net force acting on the car at this point?
- (ii) What is the speed of the car at this point?

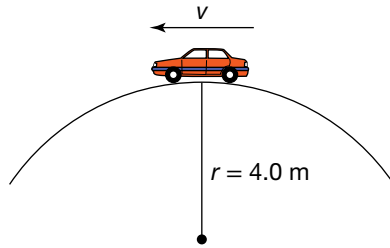

48. A gymnast, of mass  $65 \text{ kg}$ , who is swinging on the rings follows the path shown in the figure at right.
- (a) What is the speed of the gymnast at point B, if he is at rest at point A?

- (b) What is the centripetal force acting on the gymnast at point B?
- (c) Draw a labelled diagram of the forces acting on the gymnast at point B. Include the magnitude of all forces.

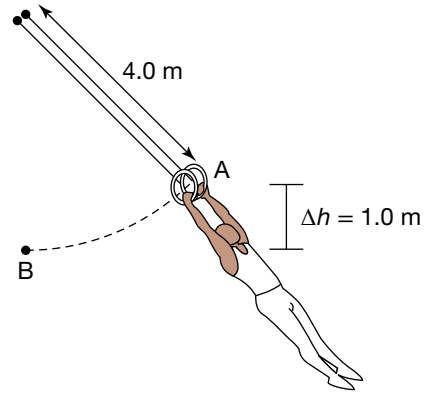

# Collisions and other interactions

## REMEMBER

Before beginning this chapter, you should be able to:

- use Newton's three laws of motion to explain movement
- apply the energy conservation model to energy transfers and transformations
- model work as the product of force and distance travelled in the direction of the force for a constant force
- equate the work done on an object by a net force to the object's change in kinetic energy
- use the area under a force–distance (or displacement) graph to determine work done by a force with changing magnitude
- define kinetic energy and strain potential energy.

## KEY IDEAS

After completing this chapter, you should be able to:

- define impulse and momentum in an isolated system
- relate impulse to a change in momentum
- analyse collisions between objects moving along a straight line in terms of impulse and momentum transfer
- apply the Law of Conservation of Momentum to straight line collisions
- analyse collisions in terms of energy transfers and transformations
- analyse energy transfers and transformations in which work is done by a force in one dimension
- analyse energy transfers and transformations during interactions between objects and springs that obey Hooke's Law
- describe the Law of Conservation of Energy and apply it to collisions between objects moving in a straight line
- describe the energy lost from a system of objects during a collision and explain the loss in terms of the Law of Conservation of Energy
- analyse elastic and inelastic collisions in terms of energy transfer and conservation of kinetic energy.



The front crumple zone of a car is designed to increase the duration of a collision. It also allows the kinetic energy of the car to be transformed into forms of energy that are less harmful to the human body.

# Impulse and momentum in a collision

Newton's second Law of Motion describes how the effect of a net force on an object depends on its mass. In sample problem 1.4, it was useful to express Newton's second law in terms of acceleration. However, it is sometimes useful to express it in terms of the change in momentum of an object. That is:

$$\begin{aligned}F_{\text{net}} &= \frac{\Delta p}{\Delta t} \\ \Rightarrow F_{\text{net}} \Delta t &= \Delta p \\ \Rightarrow F_{\text{net}} \Delta t &= m\Delta v. \quad (\text{provided the mass is constant})\end{aligned}$$

**Impulse** is the product of a force and the time interval over which it acts. Impulse is a vector quantity with SI units of N s.

The product  $F_{\text{net}} \Delta t$  is called the **impulse** of the net force. Impulse is a vector quantity which has SI units of N s. Calculations can be carried out to show that

$$1 \text{ N s} = 1 \text{ kg m s}^{-1}.$$

Thus, the effect of a net force on the motion of an object can be summarised by the statement:

$$\text{impulse} = \text{change in momentum.}$$

## Sample problem 2.1

A 1200 kg car collides with a concrete wall at a speed of  $15 \text{ m s}^{-1}$  and takes 0.06 s to come to rest.

- What is the change in momentum of the car?
- What is the impulse on the car?
- What is the magnitude of the force exerted by the wall on the car?
- What would be the magnitude of the force exerted by the wall on the car if the car bounced back from the wall with a speed of  $3.0 \text{ m s}^{-1}$  after being in contact for 0.06 s?

**Solution:** (a) Assign the initial direction of the car as positive.

$$m = 1200 \text{ kg}, u = 15 \text{ m s}^{-1}, v = 0 \text{ m s}^{-1}, \Delta t = 0.06 \text{ s}$$

$$\begin{aligned}\Delta p &= mv - mu \\ &= m(v - u) \\ &= 1200 \text{ kg} (0 - 15) \text{ m s}^{-1} \\ &= 1200 \times -15 \text{ kg m s}^{-1} \\ &= -1.8 \times 10^4 \text{ kg m s}^{-1}\end{aligned}$$

The change in momentum is  $1.8 \times 10^4 \text{ kg m s}^{-1}$  in a direction opposite to the original direction of the car.

(b) Impulse on the car = change in momentum of the car

$$= -1.8 \times 10^4 \text{ kg m s}^{-1}$$

The impulse on the car is  $1.8 \times 10^4 \text{ N s}$  in a direction opposite to the original direction of the car.

(c) Magnitude of impulse =  $F\Delta t$

$$\begin{aligned}\Rightarrow 1.8 \times 10^4 \text{ N s} &= F \times 0.06 \text{ s} \\ \Rightarrow F &= \frac{1.8 \times 10^4 \text{ N}}{0.06 \text{ s}} \\ &= 3.0 \times 10^5 \text{ N}\end{aligned}$$

(d) In this case,  $v = -3.0 \text{ m s}^{-1}$ .

$$\begin{aligned}\text{Impulse} &= m\Delta v \\ &= 1200 \text{ kg} (-3 - 15) \text{ m s}^{-1} \\ &= 1200 \times -18 \text{ kg m s}^{-1} \\ &= -2.16 \times 10^4 \text{ N s} \\ \Rightarrow 2.16 \times 10^4 \text{ N s} &= F\Delta t \\ \Rightarrow 2.16 \times 10^4 \text{ N s} &= F \times 0.06 \text{ s} \\ \Rightarrow F &= \frac{2.16 \times 10^4 \text{ N}}{0.06 \text{ s}} \\ &= 3.6 \times 10^5 \text{ N}\end{aligned}$$

### Revision question 2.1

A dodgem car of mass  $200 \text{ kg}$  strikes a barrier head-on at a speed of  $8.0 \text{ m s}^{-1}$  due west and rebounds in the opposite direction with a speed of  $2.0 \text{ m s}^{-1}$ .

- What is the impulse delivered to the dodgem car?
- If the dodgem car is in contact with the barrier for  $0.8 \text{ s}$ , what force does the barrier apply to the car?
- What force does the car apply to the barrier?

## Impulse from a graph

The force that was determined in sample problem 1.6 was actually the average force on the car. In fact, the force acting on the car is not constant. The impulse delivered by a changing force is given by:

$$\text{impulse} = F_{\text{av}}\Delta t.$$

If a graph of force versus time is plotted, the impulse can be determined from the area under the graph.

### Sample problem 2.2

The graph below describes the changing horizontal force on a  $40 \text{ kg}$  rollerskater as she begins to move from rest. Estimate her speed after  $2.0$  seconds.

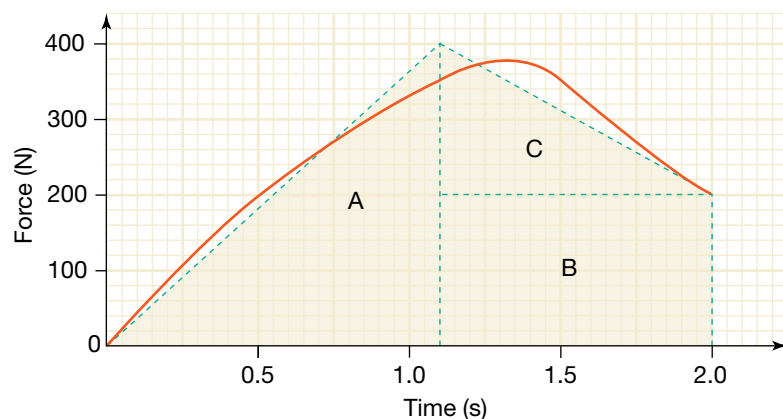

**Solution:** The magnitude of the impulse on the skater can be determined by calculating the area under the graph. This can be determined by either counting squares or by finding the shaded area.

$$\begin{aligned} \text{Magnitude of impulse} &= \text{area A} + \text{area B} + \text{area C} \\ &= \left(\frac{1}{2} \times 1.1 \times 400 + 0.9 \times 200 + \frac{1}{2} \times 0.9 \times 200\right) \text{ N s} \\ &= (220 + 180 + 90) \text{ N s} \\ &= 490 \text{ N s} \end{aligned}$$

Magnitude of impulse = magnitude of change in momentum =  $m\Delta v$

$$\begin{aligned} \Rightarrow 490 \text{ N s} &= 40 \text{ kg} \times \Delta v \\ \Rightarrow \Delta v &= \frac{490 \text{ N s}}{40 \text{ kg}} \\ &= 12 \text{ m s}^{-1} \end{aligned}$$

As her initial speed is zero (she started from rest), her speed after 2.0 seconds is  $12 \text{ m s}^{-1}$ .



Cars are designed to crumple in collisions. This increases the time interval over which the momentum changes. The magnitude of the net force on the car, and its subsequent deceleration, is decreased, making it safer for the occupants.



Bicycle helmets: Newton's second law provides an explanation for their life-saving function.

### Revision question 2.2

Estimate the speed of the rollerskater in sample problem 2.2 after 1.0 s.

## Momentum and impulse

When two or more objects collide, the change in the motion of each object can be described by Newton's Second Law of Motion. By expressing Newton's second law in the form  $\mathbf{F}_{\text{net}} = \frac{\Delta \mathbf{p}}{\Delta t}$ , it is possible to examine the effect of collisions on the human body.

When a car collides with an 'immovable' object like a large tree, its change in momentum is fixed. It is determined by the mass of the car and its initial velocity at the instant of impact. The final momentum is zero. Since the impulse is equal to the change in momentum, the impulse  $\mathbf{F}_{\text{net}} \Delta t$  is also fixed. By designing the car so that  $\Delta t$  is as large as possible, the magnitude of the net force on the car (and hence its deceleration) can be reduced. The decrease in the deceleration of the car makes it safer for the occupants.

Airbags, collapsible steering wheels and padded dashboards are all designed to increase the time interval during which the momentum of a human body changes during a collision.

The polystyrene liner of bicycle helmets is designed to crush during a collision. This increases the time interval during which the skull accelerates (or decelerates) during a collision, decreasing the average net force applied to the skull.

## Conservation of momentum

Newton's Second Law of Motion can be applied to the system of two objects just as it can be applied to each object. By applying the formula  $\mathbf{F}_{\text{net}} = \frac{\Delta \mathbf{p}}{\Delta t}$  to a system of one or more objects, another expression of Newton's second law can be written: *if the net force acting on a system is zero, the total momentum of the system does not change.*



An **isolated system** is one on which no external forces act. The only forces acting on objects in the system are those applied by other objects in the system.

### study on

Unit 3

AOS 3

Topic 3

Concept 1

#### Momentum and impulse

Summary screen and practice questions

### study on

Unit 3

AOS 3

Topic 3

Concept 1



#### See more

Examples of momentum and impulse

### study on

Unit 3

AOS 3

Topic 3

Concept 2

#### Net impulse and change in momentum

Summary screen and practice questions

### study on

Unit 3

AOS 3

Topic 3

Concept 2



#### See more

Examples of calculations using impulse–momentum

This statement is an expression of the Law of Conservation of Momentum. It is also expressed as: *if there are no external forces acting on a system, the total momentum of the system remains constant.*

A system on which no external forces act is called an **isolated system**. In practice, collisions at the surface of Earth do not take place within isolated systems. For example, a system comprising two cars that collide is not isolated because forces are applied to the cars by objects outside the system. Road friction and the gravitational pull of Earth are two examples of external forces on this system.

However, if the cars collide on an icy, horizontal road, the collision can be considered to take place in an isolated system. The sum of external forces (including the force of gravity and the normal reaction force) acting on the system of the cars would be negligible compared with the forces that each car applies to the other. A system comprising a car and a tree struck by the car could not be considered to be an isolated system because Earth exerts a large external force on the tree in the opposite direction to that applied to the tree by the car.

## Modelling a collision

Consider the system of the two blocks labelled A and B in the figure below. The blocks are on a smooth horizontal surface. The system can be treated as isolated because the gravitational force and normal reaction force on each of the blocks have no effect on their horizontal motion. Because the surface is described as smooth, the frictional force can be assumed to be negligible. The net force on the *system* is zero. Therefore, the total momentum of the *system* remains constant. The momentum of the centre of mass of the system also remains constant. However, the momentum of each of the blocks changes during the collision because each block has a non-zero net force acting on it.

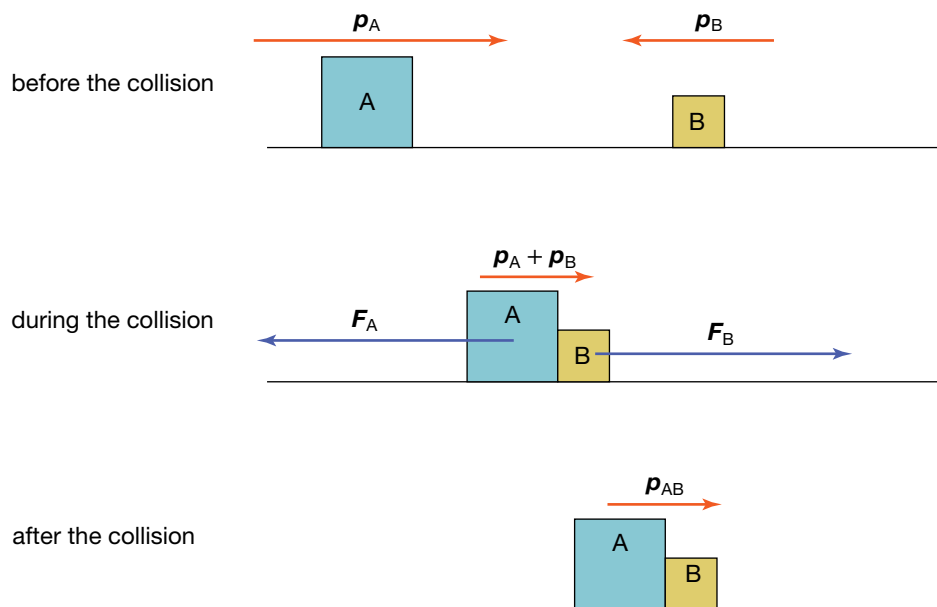

The net force on this system of two blocks is zero. Its total momentum therefore remains constant.

The force exerted on block A by block B ( $F_{\text{on A by B}}$ ) during the collision is equal in magnitude and opposite in direction to the force exerted on block B

### study on

Unit 3

AOS 3

Topic 3

Concept 3

#### Law of conservation of momentum

Summary screen and practice questions

### study on

Unit 3

AOS 3

Topic 3

Concept 3



#### See more

Examples of conservation of momentum

### eBook plus

#### Digital doc

Investigation 2.1

Who's pulling whom?

doc-18535

by block A ( $F_{\text{on B by A}}$ ). Therefore the change in momentum of block A ( $\Delta p_A$ ) is equal and opposite to the change in momentum of block B ( $\Delta p_B$ ). That is:

$$F_{\text{on A by B}} = -F_{\text{on B by A}}$$

$$\Rightarrow F_{\text{on A by B}} \Delta t = -F_{\text{on B by A}} \Delta t$$

where

$\Delta t$  = time duration of interaction

$$\Rightarrow \Delta p_A = -\Delta p_B$$

$$\Rightarrow \Delta p_A + \Delta p_B = 0$$

This result should be no surprise as, in order for the total momentum of the system consisting of the two blocks to be constant, the total change in momentum must be zero.

The interaction between blocks A and B can be summarised as follows.

- The total momentum of the system remains constant.
- The change in momentum of the system is zero.
- The momentum of the centre of mass of the system remains constant.
- The force that block A exerts on block B is equal and opposite to the force that block B exerts on block A.
- The change in momentum of block A is equal and opposite to the change in momentum of block B.

### Sample problem 2.3

A 1500 kg car travelling at  $12 \text{ m s}^{-1}$  on an icy road collides with a 1200 kg car travelling at the same speed, but in the opposite direction. The cars lock together after impact.

- What is the momentum of each car before the collision?
- What is the total momentum before the collision?
- What is the total momentum after the collision?
- With what speed is the tangled wreck moving *immediately* after the collision?

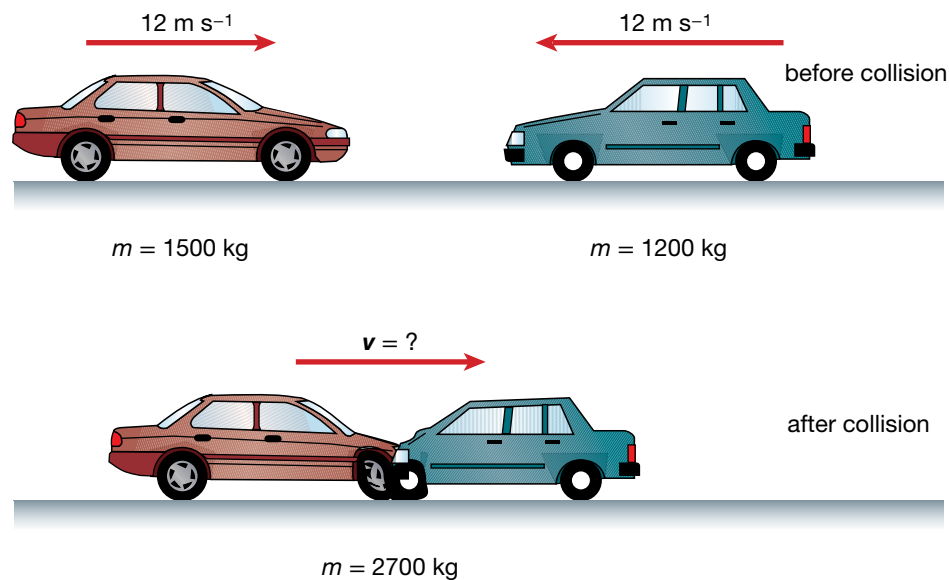

- What is the impulse on the 1200 kg car?
- What is the impulse on the 1500 kg car?

**Solution:** (a) Assign the direction in which the first car is moving as positive.

$$1500 \text{ kg car: } m = 1500 \text{ kg}, v = 12 \text{ m s}^{-1}$$

$$\begin{aligned} p &= mv \\ &= 1500 \text{ kg} \times 12 \text{ m s}^{-1} \\ &= 18\,000 \text{ kg m s}^{-1} \end{aligned}$$

$$1200 \text{ kg car: } m = 1200 \text{ kg}, v = -12 \text{ m s}^{-1}$$

$$\begin{aligned} p &= mv \\ &= 1200 \text{ kg} \times -12 \text{ m s}^{-1} \\ &= -14\,400 \text{ kg m s}^{-1} \end{aligned}$$

$$\begin{aligned} \text{(b) Momentum: } p_i &= 18\,000 \text{ kg m s}^{-1} - 14\,400 \text{ kg m s}^{-1} \\ &= 3600 \text{ kg m s}^{-1} \end{aligned}$$

(c) The description of the road suggests that friction is insignificant. It can be assumed that there are no external forces acting on the system.

$$\begin{aligned} \Rightarrow p_f &= p_i \\ &= 3600 \text{ kg m s}^{-1} \end{aligned}$$

(d) The tangled wreck can be considered as a single mass of 2700 kg.

$$m = 2700 \text{ kg}, p_f = 3600 \text{ kg m s}^{-1}, v = ?$$

$$\begin{aligned} p_f &= mv \\ \Rightarrow 2700 \text{ kg } v &= 3600 \text{ kg m s}^{-1} \\ v &= 1.3 \text{ m s}^{-1} \text{ in the direction of the initial velocity of the} \\ &\text{first car} \end{aligned}$$

(e) The impulse on the 1200 kg car is equal to its change in momentum.

$$\begin{aligned} \Delta p &= p_f - p_i \\ &= 1200 \text{ kg} \times 1.33 \text{ m s}^{-1} - (-14\,400 \text{ kg m s}^{-1}) \\ &= 1600 \text{ kg m s}^{-1} + 14\,400 \text{ kg m s}^{-1} \text{ (} p_f \text{ expressed to 2 significant} \\ &\text{figures)} \\ &= 16\,000 \text{ N s in the direction of motion of the tangled wreck.} \end{aligned}$$

(f) The impulse on the 1500 kg car is equal to the impulse on the 1200 kg car. This can be verified by calculating the change in momentum of the 1500 kg car.

$$\begin{aligned} \Delta p &= p_f - p_i \\ &= 1500 \text{ kg} \times 1.33 \text{ m s}^{-1} - (18\,000 \text{ kg m s}^{-1}) \\ &= 2000 \text{ kg m s}^{-1} - 18\,000 \text{ kg m s}^{-1} \text{ (} p_f \text{ expressed to 2 significant} \\ &\text{figures)} \\ &= -16\,000 \text{ kg m s}^{-1} \\ &= 16\,000 \text{ Ns in the direction opposite that of the 1200 kg car.} \end{aligned}$$

### Revision question 2.3

A 1000 kg car travelling north at  $30 \text{ m s}^{-1}$  ( $108 \text{ km h}^{-1}$ ) collides with a stationary delivery van of mass 2000 kg on an icy road. The two vehicles lock together after impact.

- What is the velocity of the tangled wreck immediately after the collision?
- What is the impulse on the delivery van?
- What is the impulse on the speeding car?
- After the collision, if — instead of locking together — the delivery van moved forward separately at a speed of  $12 \text{ m s}^{-1}$ , what velocity would the car have?

### AS A MATTER OF FACT

Can you feel the Earth move when you bounce a basketball on the court? If the Earth and your basketball were an isolated system, the Earth *would* move! Its change in speed can be calculated by applying the Law of Conservation of Momentum.

The mass of the Earth is  $6.0 \times 10^{24} \text{ kg}$ . If the mass of a basketball is 600 g and it strikes the ground with a velocity of  $12 \text{ m s}^{-1}$  downwards, estimate the velocity of the Earth after impact.

## Work in energy transfers and transformations

Energy can be transferred from one object to another as a result of a temperature difference (heating or cooling), by electromagnetic and nuclear radiation, or by the action of a force.

When you serve in a game of tennis, energy is transferred from the tennis racquet to the tennis ball. The energy is transferred to the tennis ball by the force applied to it by the tennis racquet. Energy can also be transformed from one form into another by the action of a force. For example, as a dropped tennis ball falls to the ground, gravitational potential energy is transformed into kinetic energy. The transformation of the energy possessed by the ball from one form into another is caused by the gravitational force acting on the tennis ball.

**Kinetic energy** is the energy associated with the movement of an object. Like all forms of energy, kinetic energy is a scalar quantity.

**Strain potential energy** is the energy stored in an object as a result of a reversible change in shape.

**Gravitational potential energy** is the energy stored in an object as a result of its position relative to another object to which it is attracted by the force of gravity.

### REMEMBER THIS

**Kinetic energy** is the energy associated with the movement of an object. The kinetic energy  $E_k$  of an object of mass  $m$  and speed  $v$  is expressed as:

$$E_k = \frac{1}{2} mv^2.$$

**Strain potential energy**, also known as elastic potential energy, is energy that can be stored in an object by changing its shape. Compressing, stretching, bending or twisting objects can increase their strain potential energy. Strain potential energy can be transformed into other forms of energy by allowing the object to resume its natural shape.

**Gravitational potential energy** is the energy stored in an object as a result of its position relative to another object to which it is attracted by the force of gravity. The gravitational potential energy of an object increases as it moves away from the object to which it is attracted and decreases as it moves towards an object to which it is attracted.

**Work** is the energy transferred to or from another object by the action of a force. Work is a scalar quantity.

## Getting down to work

The amount of energy transferred to or from another object or transformed to or from another form by the action of a force is called **work**.

The work  $W$  done when a force  $F$  causes a displacement  $s$  in the direction of the force is defined as:

$$\begin{aligned} \text{work} &= \text{magnitude of the force} \\ &\quad \times \text{displacement in the direction of the force} \\ W &= F \times s. \end{aligned}$$

Work is a scalar quantity. The SI unit of work is the joule. One joule of work is done when a force of magnitude of 1 newton causes a displacement of 1 metre in the same direction of the force.

The work done on an object of mass  $m$  by the net force acting on it is given by:

$$\begin{aligned} W &= F_{\text{net}} s \\ &= mas \end{aligned}$$

where

$s$  = the magnitude of the object's displacement.

But  $s$  can be expressed as  $\frac{(v^2 - u^2)}{2a}$  because  $v^2 = u^2 + 2as$ ,

where

$a$  = acceleration

$v$  = final velocity

$u$  = initial velocity.

$$\begin{aligned} \text{Thus } W &= \frac{ma(v^2 - u^2)}{2a} \\ &= \frac{1}{2} mv^2 - \frac{1}{2} mu^2 \\ &= \Delta E_k. \end{aligned}$$

In other words, the work done on an object by the net force is equal to the change in kinetic energy of the object.

If the initial kinetic energy of the object is zero, the work done by the net force is equal to the final kinetic energy. If work is done to stop an object, the work done is equal to the initial kinetic energy.

### study on

Unit 3 **When work is done**

AOS 3 Summary screen and practice questions

Topic 2

Concept 1

### study on

Unit 3 **Kinetic energy**

AOS 3 Summary screen and practice questions

Topic 2

Concept 3

### study on

Unit 3

AOS 3

Topic 2

Concept 1



**See more**  
Work done by force

### Solution:

### study on

Unit 3

AOS 3

Topic 2

Concept 1



**Do more**  
Work done by force

### Sample problem 2.4

A car of mass 600 kg travelling at  $12 \text{ m s}^{-1}$  collides with a concrete wall and comes to a complete stop over a distance of 30 cm. Assume that the frictional forces acting on the car are negligible.

- (a) How much work was done by the concrete wall to stop the car?  
(b) What was the magnitude of net force acting on the car as it came to a halt?

(a) The net force on the car is equal to the force applied by the wall. The work done by the wall,  $W$ , is given by:

$$\begin{aligned} W &= \Delta E_k \\ &= \frac{1}{2} mv^2 \\ &= \frac{1}{2} \times 600 \text{ kg} \times (12 \text{ m s}^{-1})^2 \\ &= 4.32 \times 10^4 \text{ J} \end{aligned}$$

The work done by the wall was  $4.3 \times 10^4 \text{ J}$ .

(b) The magnitude is determined by:

$$W = F_{\text{av}} s$$

$$4.32 \times 10^4 \text{ J} = F_{\text{net}} \times 0.30 \text{ m} \quad (F_{\text{av}} = F_{\text{net}} \text{ in this case})$$

$$F_{\text{net}} = 1.44 \times 10^5 \text{ N}$$

The magnitude of net force was  $1.4 \times 10^5 \text{ N}$ .

### Revision question 2.4

A car travelling at  $15 \text{ m s}^{-1}$  brakes heavily before colliding with another vehicle. The total mass of the car is  $800 \text{ kg}$ . The car skids for a distance of  $20 \text{ m}$  before making contact with the other vehicle at a speed of  $5 \text{ m s}^{-1}$ .

(a) How much work is done on the car by road friction during braking?

(b) Calculate the average road friction during braking.

#### study on

Unit 3

**Work and the force–distance graph**

AOS 3

Topic 2

Summary screen and practice questions

Concept 2

The amount of work done by a changing force is given by:

$$W = F_{\text{av}} s$$

where

$F_{\text{av}}$  = the average force.

It can be determined by calculating the area under a graph of force versus displacement in the direction of the force.

## Gravitational potential energy

When you drop an object, the gravitational force does work on it, transforming gravitational potential energy to kinetic energy as it falls. When you lift an object, you do work on the object to increase its gravitational potential energy. (Energy is transferred from your body to the object.)

A quantitative definition of gravitational potential energy can be stated by determining how much work is done in lifting an object of mass  $m$  through a height  $\Delta h$ . In order to lift an object without changing its kinetic energy, a force  $F$  equal to the weight of the object is needed. The work done is:

$$W = F s$$

$$= mg \Delta h$$

$$\Rightarrow \Delta E_g = mg \Delta h$$

where

$\Delta E_g$  = change in gravitational potential energy.

This formula provides a way of calculating changes in gravitational potential energy. If the gravitational potential energy of an object is defined to be a zero at a reference height, a formula for the quantity of gravitational potential energy can be found for an object at height  $h$  above the reference height.

$$\Delta E_g = mg \Delta h$$

$$\Rightarrow E_g - 0 = mg (h - 0)$$

$$\Rightarrow E_g = mgh$$

Usually the reference height is ground or floor level. Sometimes it might be more convenient to choose another reference height. However, it is the *change* in gravitational potential energy that is most important in investigating energy transformations.

#### study on

Unit 3

**Gravitational potential energy**

AOS 3

Topic 2

Summary screen and practice questions

Concept 4

**Interactivity**

The slippery slope  
int-6607

It is important to remember that the change in gravitational potential energy as a result of a particular change in height is independent of the path taken. The change in gravitational potential energy of the diver in the next figure is the same whether she falls from rest, jumps upwards first or completes a complicated dive with twists and somersaults.

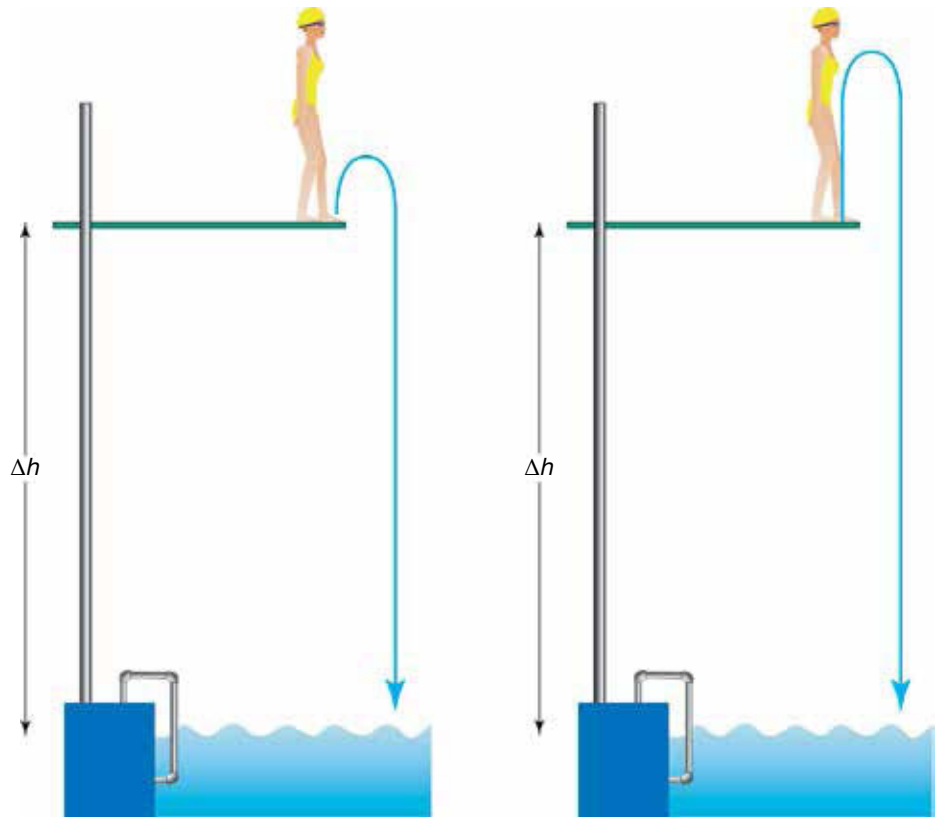

The change in gravitational potential energy of the diver is independent of the path taken.

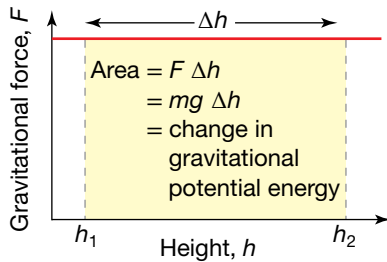

Because a change in gravitational potential energy is equal to the work done on an object by, or against, the gravitational force, it can be found by calculating the area under a graph of force versus height.

**REMEMBER THIS**

The quantity  $g$  is known as the gravitational field strength (sometimes just referred to as gravitational field).

The change in gravitational potential energy of an object can also be determined by calculating the area under a graph of gravitational field strength versus height (equal to  $g\Delta h$ ) and multiplied by its mass.

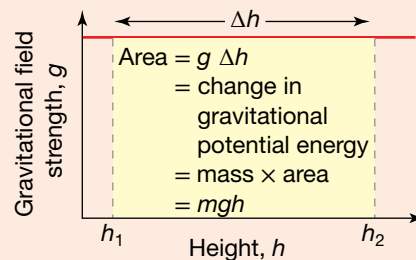

### Sample problem 2.5

A water slide has a drop of 9.0 m. A child of mass 35 kg sits at the top.

- (a) What is the child's gravitational potential energy?
- (b) How fast will the child be travelling when they hit the water? Ignore any frictional losses.

**Solution:** (a)  $\Delta E_g = mg\Delta h$   
 $= 35 \text{ kg} \times 9.8 \text{ m s}^{-2} \times 9.0 \text{ m}$   
 $= 3100 \text{ J}$

(b)  $\frac{1}{2}mv^2 = mg\Delta h$ , so  $v^2 = 2g\Delta h$ .  
 $v = \sqrt{2 \times 9.8 \text{ m s}^{-2} \times 9.0 \text{ m}}$   
 $= 13 \text{ m s}^{-1}$

### Revision question 2.5

The maximum height of a roller coaster ride is 30 m above the ground. The lowest height of the ride is 5.0 m.

- (a) What is the change in gravitational potential energy of a 60 kg passenger?
- (b) If the passenger was travelling at  $0.5 \text{ m s}^{-1}$  at the top, what would be their maximum speed at the lowest point?

## Strain potential energy and springs

The energy stored in an object by changing its length or shape is usually called strain potential energy if the object can return naturally to its original shape. Work must be done on an object by a force in order to store energy as strain potential energy. However, when objects are compressed, stretched, bent or twisted, the force needed to change their shape is not constant. For example, the more you stretch a rubber band, the harder it is to stretch it further. The more you compress the sole of a running shoe, the harder it is to compress it further.

The strain potential energy of an object can be determined by calculating the amount of work done on it by the force. The work can also be determined by calculating the area under a graph of force versus displacement. In the case of a simple spring, rubber band or running shoe, the gain in strain potential energy can be calculated by determining the area under a graph of force versus extension or force versus compression.

When an object loses strain potential energy, it can do work on other objects. The amount of work done by the object (and hence the change in potential energy) is equal to the area under a graph of force versus compression.

When you close the lid of a jack-in-the-box, you do work on the spring to increase its strain potential energy, transferring energy from your body to the spring. The spring does work on the 'jack' when the lid is opened, transforming strain potential energy into kinetic energy.



A jack-in-the-box. When the lid opens, the spring does work on the 'jack', transforming strain potential energy into kinetic energy.

### Sample problem 2.6

The graph on page 59 shows how the force required to compress a jack-in-the-box spring changes as the compression of the spring increases.



How much energy is stored in the spring when it is compressed by 25 cm?

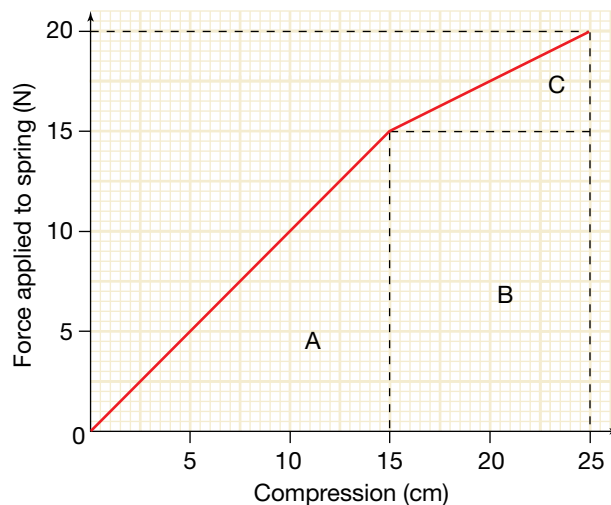

**Solution:** The energy stored in the spring is equal to the amount of work done on it.

$$\begin{aligned}
 W &= \text{area under graph} \\
 &= \text{area A} + \text{area B} + \text{area C} \\
 &= \left(\frac{1}{2} \times 0.15 \text{ m} \times 15 \text{ N}\right) + (0.10 \text{ m} \times 15 \text{ N}) + \left(\frac{1}{2} \times 0.10 \text{ m} \times 5.0 \text{ N}\right) \\
 &= 1.125 \text{ J} + 1.5 \text{ J} + 0.25 \text{ J} \\
 &= 2.9 \text{ J}
 \end{aligned}$$

### Revision question 2.6

If the length of the spring represented by the graph above is 35 cm:

- how much strain potential energy is stored in it when its length is 15 cm?
- what is the length of the spring when 0.50 J of strain potential energy is stored in it due to compression? (This question is a little harder.)

## Hooke's Law springs to mind

Robert Hooke (1635–1703) investigated the behaviour of elastic springs and found that the **restoring force** exerted by the spring was directly proportional to its displacement. The force is called a restoring force because it acts in a direction that would restore the spring to its natural length.

In vector notation, Hooke's Law states:

$$F = -k\Delta x$$

where

$F$  = restoring force

$\Delta x$  = displacement of the end of the spring from its natural position

$k$  = spring constant (also known as force constant).

The negative sign is necessary because the restoring force is always in the opposite direction to the displacement.

It is usually more convenient to express Hooke's Law in terms of magnitude so that the negative sign is not necessary. That is:

$$F = k\Delta x$$

where

$F$  = magnitude of the restoring force

$\Delta x$  = compression or extension of the spring

$k$  = spring constant.

The **restoring force** applied by a spring is the force it applies to resist compression or extension.

### study on

Unit 3

**Hooke's Law**

AOS 3

Summary screen

Topic 2

and practice

Concept 5

questions

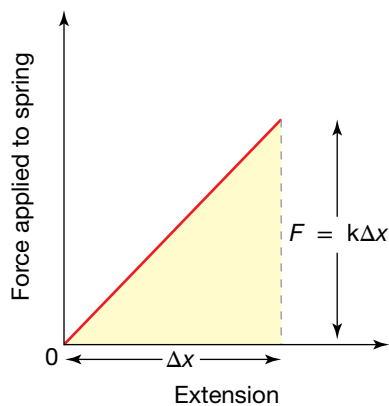

The strain potential energy of a spring is equal to the area under the graph. If the spring obeys Hooke's Law, strain potential energy =  $\frac{1}{2}k(\Delta x)^2$ .

### study on

Unit 3

**Strain potential energy**

AOS 3

Summary screen and practice questions

Topic 2

Concept 6

- Some important points to remember about Hooke's Law are listed below.
- Hooke's Law applies to springs within certain limits. If a spring is compressed or extended so much that it is permanently deformed — unable to return to its original natural length — Hooke's Law no longer applies.
  - The magnitude of the restoring force is equal to the force that is compressing or extending the spring (Newton's third law).
  - The measure  $\Delta x$  is not the length of the spring. Rather, it is a measure of its compression or extension — the *change* in length of the spring.
  - The spring constant has SI units of  $\text{N m}^{-1}$ .
  - A graph of  $F$  versus  $\Delta x$  produces a straight line with a gradient of  $k$ .
- The strain potential energy of a spring that obeys Hooke's Law can be expressed as:

$$\text{strain potential energy} = \frac{1}{2}k(\Delta x)^2.$$

This can be verified by calculating the work done in extending the spring described in the figure at left. This is done by calculating the area under the graph of force versus extension.

$$\begin{aligned} \text{Strain potential energy} &= \text{work done on spring} \\ &= \text{area under graph} \\ &= \frac{1}{2} \times \Delta x \times k\Delta x \\ &= \frac{1}{2}k(\Delta x)^2 \end{aligned}$$

### Sample problem 2.7

The graph below left describes the behaviour of two springs that obey Hooke's Law. Both springs are extended by 20 cm.

- What is the spring constant of spring A?
- Which spring has the greatest spring constant?
- What is the strain potential energy of spring B?

**Solution:**

- The spring constant  $k$  is equal to the gradient of the graph.

$$\begin{aligned} \Rightarrow k &= \frac{40 \text{ N}}{0.20 \text{ m}} \\ &= 200 \text{ N m}^{-1} \end{aligned}$$

- The gradient of the graph for spring A is greater than that for spring B. Therefore, spring A has a greater spring constant than spring B — in fact, it is twice as great.
- Since the spring obeys Hooke's Law, the strain potential energy of spring B can be calculated using the formula:

$$\begin{aligned} \text{strain potential energy} &= \frac{1}{2}k(\Delta x)^2 \\ k &= \text{gradient} \\ &= \frac{20 \text{ N}}{0.20 \text{ m}} \\ &= 100 \text{ N m}^{-1} \end{aligned}$$

$$\begin{aligned} \text{strain potential energy} &= \frac{1}{2} \times 100 \text{ N m}^{-1} \times (0.20 \text{ m})^2 \\ &= 2.0 \text{ J.} \end{aligned}$$

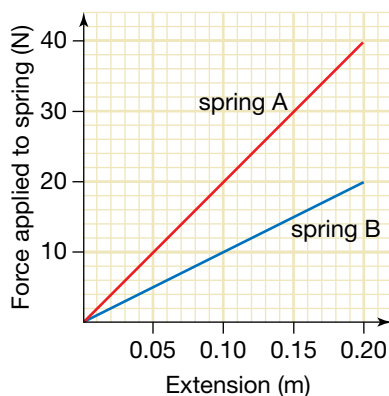

### Revision question 2.7

- (a) What is the spring constant of spring B, described in sample problem 2.4?  
(b) How much strain potential energy is stored in spring A when it is extended by 20 cm?

### Sample problem 2.8

A toy car of mass 0.50 kg is pushed against a spring so that it is compressed by 0.10 m. The spring obeys Hooke's Law and has a spring constant of  $50 \text{ N m}^{-1}$ . When the toy car is released, what will its speed be at the instant that the spring returns to its natural length? Assume that there is no friction within the spring and no frictional force resisting the motion of the toy car.

**Solution:** The strain potential energy stored in the spring equals  $\frac{1}{2} k(\Delta x)^2$ .

$$\begin{aligned}\text{strain potential energy gained} &= \frac{1}{2} k(\Delta x)^2 \\ &= \frac{1}{2} \times 50 \text{ N m}^{-1} \times (0.10 \text{ m})^2 \\ &= 0.25 \text{ J}\end{aligned}$$

$$\Rightarrow \frac{1}{2} mv^2 = 0.25 \text{ J}$$

$$\frac{1}{2} \times 0.50 \text{ kg} \times v^2 = 0.25 \text{ J}$$

$$v^2 = \frac{0.25 \text{ J}}{\frac{1}{2} \times 0.50 \text{ kg}}$$

$$v = 1.0 \text{ m s}^{-1}$$

The speed of the toy car is  $1.0 \text{ m s}^{-1}$ .

### Revision question 2.8

A model car of mass 0.40 kg travels along a frictionless horizontal surface at a speed of  $0.80 \text{ m s}^{-1}$ . It collides with the free end of a spring that obeys Hooke's Law. The spring constant is  $100 \text{ N m}^{-1}$ .

- (a) How much strain potential energy is stored in the spring when the car comes to a stop?  
(b) What is the maximum compression of the spring?

## Elastic and inelastic collisions

When two objects collide, the total energy of the system, which includes the two objects and the surroundings (the air and ground), is conserved. However, the total energy of the two objects is not conserved, because when they make contact some of their energy is transferred to the surroundings.

Energy cannot be created or destroyed. It can only be converted from one form into another. This is the Law of Conservation of Energy. During most energy transformations, some energy is degraded into less useful forms, heating the surroundings and causing noise. If air resistance and other types of friction are small, the amount of energy degraded can be considered negligible.

### eBookplus

#### Digital doc

Investigation 2.2  
The properties of a coil spring  
doc-18536

### study on

Unit 3

**Conservation of energy**

AOS 3

Summary screen  
and practice  
questions

Topic 2

Concept 7

**Interactivity**

Colliding dodgemes  
int-6610

**study on**

**Unit 3** **Collision between two objects**  
**AOS 3** Summary screen and practice questions  
**Topic 3**  
**Concept 4**

**study on**

**Unit 3**   
**AOS 3**  
**Topic 3** **See more**  
**Concept 4** Conservation of momentum (colliding objects)

**study on**

**Unit 3**   
**AOS 3**  
**Topic 3** **Do more**  
**Concept 4** Sticky collisions and momentum conservation

## A tale of two collisions

The Law of Conservation of Momentum states: *when a collision between two objects occurs, the total momentum of the two objects remains constant.*

This statement is valid as long as the two objects comprise an isolated system; that is, as long as there are no external forces acting on each of the objects.

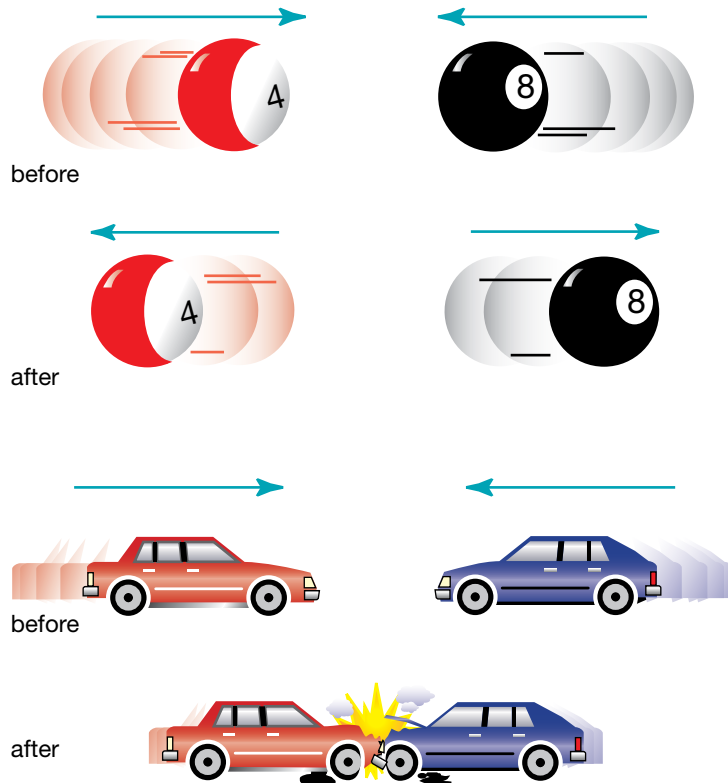

Two collisions — momentum is conserved in both of them.

Consider the differences between the two collisions shown in the diagram above: a collision between two billiard balls on a smooth, level billiard table, and a head-on collision between two cars travelling in opposite directions on a level, icy road.

The two billiard balls can be considered to be an isolated system. The total momentum of the two billiard balls immediately after the collision is the same as it was immediately before the collision. (It is also the same during the collision. Momentum, unlike energy, cannot be stored.) The two cars can also be considered to be an isolated system, because the frictional forces on the cars are relatively small. Therefore, the total momentum of the cars immediately after the collision is the same as it was immediately before the collision.

## What's the difference?

Apart from the difference between the masses of the objects involved in the collisions, there is one obvious difference.

- The collision between the two billiard balls is an almost perfect **elastic collision**. An elastic collision is one in which the total kinetic energy after the collision is the same as it was before the collision. The sound made when the balls collide provides evidence that the collision is not quite perfectly elastic. Some of the initial kinetic energy of the system is transferred to particles in the surrounding air (and within the balls themselves).

In an **elastic collision** the total kinetic energy is conserved.

## study on

Unit 3

**Inelastic collisions**

AOS 3

Summary screen and practice questions

Topic 3

Concept 5

## study on

Unit 3

**Elastic collisions**

AOS 3

Summary screen and practice questions

Topic 3

Concept 6

However, when making predictions about the outcome of such a collision, it would be quite reasonable to treat the collision as a perfectly elastic one. In fact, a perfectly elastic 'collision' can only take place if the interacting objects do not actually make contact with each other. A perfectly elastic interaction can take place when two electrons move towards each other in a vacuum.

- The collision between the two cars is an inelastic collision. Even though momentum is conserved, the total kinetic energy of the cars after the collision is considerably less than it was before the collision. A significant proportion of the initial kinetic energy of the system is transferred to the bodies of both cars, changing their shapes and heating them. Some of the initial kinetic energy is also transformed to sound energy.

## Energy transformations in collisions

Whether or not a collision is elastic depends on what happens to the colliding objects during the collision. When two objects collide, each of the objects is deformed. Each object applies a force on the other (in fact, the forces are equal and opposite!). The size of the applied force increases as the deformation increases (just like a compressed spring). If each object behaves elastically, all of the energy stored as strain potential energy during deformation is returned to the other object as kinetic energy. The collision is therefore elastic.

In the collision between the two billiard balls discussed above, the work done on each billiard ball as it returns to its original shape is almost as much as the work done during deformation. Therefore, almost all of the strain potential energy stored in each ball while they are in contact with each other is returned as kinetic energy.

The graph (below left) shows that in an elastic collision the work done on an object during deformation (the area under the force versus deformation graph) is equal to the work the object does on the other object as it returns to its original straight. The graph (below right) illustrates a collision between an electron and second electron. The work done to slow down the approaching electron is the same as the work done to increase its speed during separation.

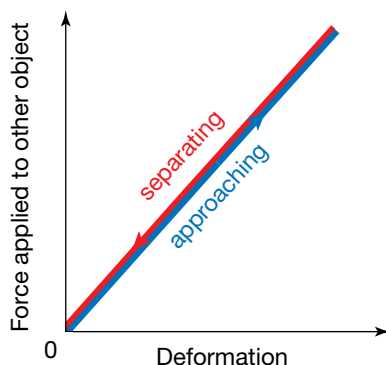

A graph of force versus deformation for an object involved in an elastic collision

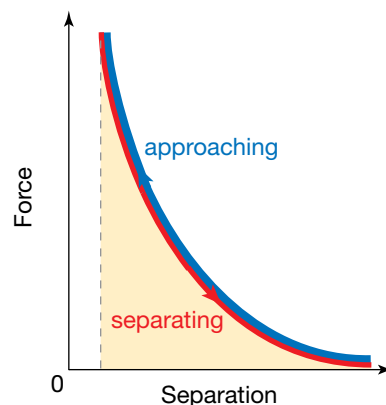

A graph of force versus separation for an electron approaching another electron

The graph on page 64 illustrates that even though the total kinetic energy and total strain potential energy change during an elastic collision, the sum of the kinetic energy and strain potential energy is constant. In an inelastic collision the sum of the kinetic energy and strain potential energy decreases

**Digital doc**

Investigation 2.3  
Elastic and inelastic interactions  
doc-18537

because energy is lost from the system of objects as heat, permanent deformation of the objects and sound.

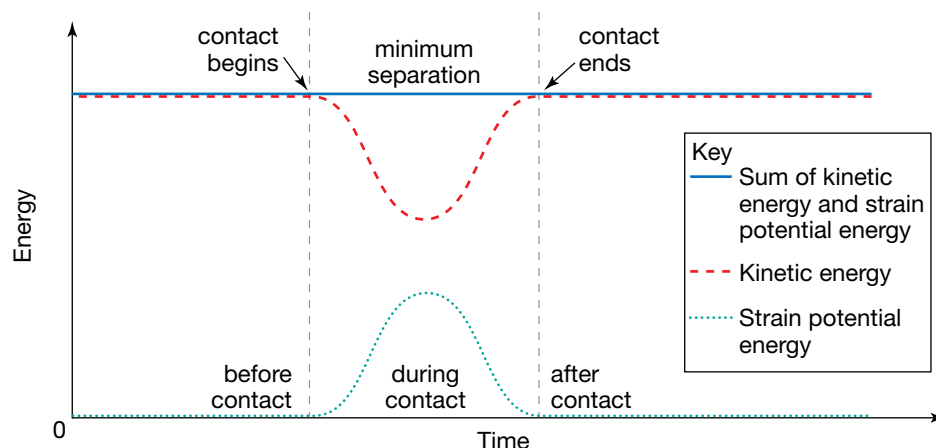

Energy transformations during an elastic collision

## PHYSICS IN FOCUS

### Crumple zones

The crumple zones at the front and rear of cars are designed to reduce injuries by ensuring that the collisions are not elastic. Between the crumple zones is the more rigid passenger 'cell', designed to protect occupants from the intrusion of the engine or other solid objects that would injure or even kill them.



Crumple zones at the front and rear of cars absorb energy and reduce the magnitude of acceleration during an accident.

In the previous section on momentum, an analysis using Newton's Second Law of Motion reveals that the acceleration of the occupants is decreased because the time during which the velocity changes is increased if the car is designed to crumple.

The reason that crumple zones work can be also understood by analysing a collision in terms of energy transformations. When a car collides with a rigid object, the object does work on the car, transforming its kinetic energy into other forms of energy and transferring some of this energy to the surroundings. A lot of the kinetic energy of the car is used to heat the body of the car and the surrounding air. Without the crumple zone, the distance over which the force acts would be less and the cars would be more inclined to rebound. The result would be a greater acceleration (in magnitude) of occupants, and therefore a greater chance of serious injury or death.

The effectiveness of gloves in baseball and cricket can also be analysed in terms of energy. Like the crumple zones of cars, they are designed to ensure that collisions are inelastic.

### Sample problem 2.9

A white car of mass 800 kg is driven along a slippery straight road with a speed of  $20 \text{ m s}^{-1}$  ( $72 \text{ km h}^{-1}$ ). It collides with a stationary blue car of mass 700 kg. During the collision the blue car is pushed forwards with a speed of  $12 \text{ m s}^{-1}$ .

- (a) What is the speed of the white car after the collision?  
 (b) Show that the collision is not elastic.

**Solution:** (a) Assign the direction in which the white car is moving as positive. Assume that friction in this case is negligible. Therefore momentum is conserved.

The initial momentum of the system,  $p_i$ , is given by:

$$\begin{aligned} p_{\text{white}} + p_{\text{blue}} &= 800 \text{ kg} \times 20 \text{ m s}^{-1} + 0 \text{ kg m s}^{-1} \\ &= 16\,000 \text{ kg m s}^{-1}. \end{aligned}$$

The final momentum of the system,  $p_f$ , is given by:

$$\begin{aligned} p_{\text{white}} + p_{\text{blue}} &= 800 \text{ kg} \times v_{\text{white}} + 700 \text{ kg} \times 12 \text{ m s}^{-1} \\ &= 800 \text{ kg} \times v_{\text{white}} + 8400 \text{ kg m s}^{-1} \end{aligned}$$

where

$v_{\text{white}}$  = velocity of the white car after the collision.

But since  $p_f = p_i$ :

$$\begin{aligned} 800 \text{ kg} \times v_{\text{white}} + 8400 \text{ kg m s}^{-1} &= 16\,000 \text{ kg m s}^{-1} \\ \Rightarrow 800 \text{ kg} \times v_{\text{white}} &= 7600 \text{ kg m s}^{-1} \\ \Rightarrow v_{\text{white}} &= 9.5 \text{ m s}^{-1} \end{aligned}$$

The speed of the white car after the collision is  $9.5 \text{ m s}^{-1}$ .

- (b) If the collision is elastic, the total kinetic energy after the collision will be the same as the total kinetic energy before the collision.

Total kinetic energy before the collision is given by:

$$\frac{1}{2} \times 800 \text{ kg} \times (20 \text{ m s}^{-1})^2 + 0 = 160\,000 \text{ J}.$$

Total kinetic energy after the collision is given by:

$$\frac{1}{2} \times 800 \text{ kg} \times (9.5 \text{ m s}^{-1})^2 + \frac{1}{2} \times 700 \text{ kg} \times (12 \text{ m s}^{-1})^2 = 86\,500 \text{ J}.$$

Kinetic energy is not conserved. The collision is not elastic.

#### eBookplus

##### Weblink

Elastic and inelastic collisions

#### eBookplus

##### Weblink

Car safety systems

### Revision question 2.9

- (a) A green dodgem car of mass 400 kg has a head-on collision with a red dodgem car of mass 300 kg. Both dodgem cars were travelling at a speed of  $2.0 \text{ m s}^{-1}$  before the collision. What is the rebound speed of the green dodgem car if the red dodgem car rebounds at a speed of:
- (i)  $1.0 \text{ m s}^{-1}$
  - (ii)  $2.0 \text{ m s}^{-1}$ ?
- (b) Are either of the collisions in part (a) elastic? If so, which one?

### AS A MATTER OF FACT

Most deaths and injuries in car crashes are caused by collisions between occupants and the interior of the car. Driver airbags are designed to reduce the injuries caused by impact with the steering wheel. They should inflate only in head-on collisions.



Testing airbags

Airbags inflate when the crash sensors in the car detect a large deceleration. When the sensors are activated, an electric current is used to ignite a chemical called sodium azide ( $\text{NaN}_3$ ). The sodium azide stored in a metal container at the opening of the airbag burns rapidly, producing sodium compounds and nitrogen gas. The reaction is explosive, causing a noise like the sound of gunfire. The nitrogen gas inflates the airbag to a volume of about 45 L in only 30 ms. When the driver's head makes contact with the airbag, the airbag deflates as the nitrogen gas escapes through vents in the bag. The dust produced when an airbag is activated is a mixture of the talcum powder used to lubricate the bags and the sodium compounds produced by the chemical reaction. Deflation must be rapid enough to allow the driver to see ahead after the accident. The collision of the driver with the airbag is inelastic. Most of the kinetic energy of the driver's body is transferred to the nitrogen gas as the kinetic energy of its molecules.



# Chapter review



## Summary

- Impulse is the product of a force and the time interval over which it acts. Impulse is a vector quantity with SI units of N s.
- The change in momentum of an object is equal to the impulse of the net force acting on it.
- The impulse delivered to an object by a force can be determined from the area under the graph of the force versus time.
- If there are no external forces acting on a system, the total momentum of the system remains constant. This statement is an expression of the Law of Conservation of Momentum.
- The Law of Conservation of Momentum can be applied to collisions between two objects moving along a straight line, as long as external forces such as friction are negligible.
- When two objects collide, the impulse applied to the first object by the second object is equal and opposite in direction to the impulse applied to the second object by the first object.
- The amount of energy transferred to or from another object, or transformed to or from another form, by the action of a force is called work.
- The work done on an object by the net force is equal to the object's change in kinetic energy.
- A change in gravitational potential energy is equal to the work done by or against a gravitational force and is equal to  $mg\Delta h$ . It can also be determined by calculating the area under a graph of force versus height.
- The work done when a force causes a displacement along the line of action of the force is equal to the product of the magnitude of the force and the displacement.
- Strain potential energy is the energy stored in an object as a result of a reversible change in shape.
- When an elastic spring is compressed or extended, the spring applies a restoring force in a direction that would restore the spring to its natural length. The restoring force  $F$  is related to the displacement of the spring from its natural length by the equation  $F = -k\Delta x$ , where  $k$  is the spring constant and  $\Delta x$  is the displacement from the spring's natural length. This equation is an expression of Hooke's Law. The strain potential energy stored in a spring that obeys Hooke's Law is equal to  $\frac{1}{2}k(\Delta x)^2$ .
- The Law of Conservation of Energy applies to collisions as it applies to all interactions between objects. However, the total energy of the objects that collide is not conserved, because when the objects make contact some of their energy is transferred to the surroundings.
- Collisions in which the total kinetic energy of the objects is conserved are called elastic collisions. In elastic collisions, the work done on each object during deformation is the same as the work done as each object resumes its original shape. Collisions in which the total energy is not conserved are called inelastic collisions.
- Momentum is conserved in both elastic and inelastic collisions as long as the external forces are negligible.
- Many safety features of motor vehicles are designed to reduce injuries by ensuring that collisions between vehicles, or between vehicles and other objects, are not elastic.

## Questions

In answering the questions on the following pages, assume, where relevant, that the magnitude of the gravitational field at Earth's surface is  $10 \text{ N kg}^{-1}$ .

### Momentum and impulse

1. Describe the relationship between impulse and momentum in eight words or fewer.
2. Regarding momentum, what is the fundamental purpose of airbags, collapsible steering wheels and padded dashboards in passenger vehicles?
3. Can an object have energy but no momentum? Explain. Can an object have momentum, but no energy?

### Conservation of momentum

4. In a real collision between two cars on a bitumen road on a dry day, is it reasonable to assume that the total momentum of the two cars is conserved? Explain your answer.
5. An empty railway cart of mass  $500 \text{ kg}$  is moving along a horizontal low-friction track at a velocity of  $3.0 \text{ m s}^{-1}$  due south when a  $250 \text{ kg}$  load of coal is dropped into it from a stationary container directly above it.
  - (a) Calculate the velocity of the railway cart immediately after the load has been emptied into it.
  - (b) What happens to the vertical momentum of the falling coal as it lands in the railway cart?
  - (c) If the fully loaded railway cart is travelling along the track at the velocity calculated in (a) and the entire load of coal falls out through a large hole in its floor, what is the final velocity of the cart?
6. Two iceskaters, Melita and Dean, are performing an ice dancing routine in which Dean (with a mass of  $70 \text{ kg}$ ) glides smoothly at a velocity of  $2.0 \text{ m s}^{-1}$  due east towards a stationary Melita (with a mass of  $50 \text{ kg}$ ), holds her around the waist and they both

move off together. During the whole move, no significant frictional force is applied by the ice.

- What is Dean's momentum before making contact with Melita?
  - Where is the centre of mass of the system comprising Dean and Melita 3.0 s before impact?
  - What is the velocity of the centre of mass of the system before impact?
  - Calculate the common velocity of Melita and Dean immediately after impact.
  - What impulse is applied to Melita during the collision?
7. A car of mass 1500 kg travelling due west at a speed of  $20 \text{ m s}^{-1}$  on an icy road collides with a truck of mass 2000 kg travelling at the same speed in the opposite direction. The vehicles lock together after impact.
- What is the velocity of the tangled wreck immediately after the collision?
  - Use your answer to part (a) to determine what impulse is applied to the truck during the collision.
  - Which vehicle experiences the greatest (in magnitude) change in velocity?
  - Which vehicle experiences the greatest change in momentum?
  - Which vehicle experiences the greatest force?
8. Are you generally safer in a big car or a small car in the event of an accident? If so, what is the reason? By considering the questions below you might be able to work it out by making some estimates and applying Newton's laws to each car. You might also have to make some assumptions in predicting the outcomes of such a collision. Consider the following questions.
- How do the forces on each car compare?
  - How do the masses of the cars compare with each other?
  - What is the subsequent change in velocity of each car as a result of the collision?
  - How does your body move during a collision and what does it collide with?

### Work in energy transfers and transformations

9. A 900 kg car travelling at  $20 \text{ m s}^{-1}$  on an icy road collides with a stationary truck. The car comes to rest over a distance of 40 cm.
- What is the initial kinetic energy of the car?
  - How much work is done by the truck to stop the car?
  - What average force does the car apply to the truck during the collision?
10. A rock is dropped from a height into mud and penetrates. If it was dropped from twice the height, what would be the depth of penetration compared to the depth from the first drop?
11. A car travelling at  $60 \text{ km h}^{-1}$  collides with a large tree. The front crumple zone folds, allowing the

car to come to a complete stop over a distance of 70 cm. The driver, of mass 70 kg, is wearing a properly fitted seatbelt. As a result, the driver's body comes to rest over the same distance as the whole car.

- Determine the amount of work done by the seatbelt in stopping the driver.
- What is the magnitude of the average force applied to the driver by the seatbelt?
- Estimate the magnitude of the force that would be exerted by the front interior of the car on an unrestrained driver in the same accident. Assume that the driver does not crash through the windscreen.

### Gravitational potential energy

12. Calculate the gravitational potential energy of the following objects.
- A 70 kg pole vaulter 6.0 metres above the ground
  - A pile driver of mass 80 kg raised 7.0 m above the pile
  - A 400 kg lift at the bottom of an 80 m mine shaft relative to the ground
13. Estimate the gravitational potential energy of the following objects.
- The roller coaster in the opening image of chapter 1 when it is at the top of the loop, with reference to the bottom of the loop
  - The high jumper in the section on projectile motion in chapter 1 with reference to the ground
  - This textbook with reference to the floor
  - A tennis ball about to be hit during a serve with reference to the ground
  - A 20-storey building with reference to the ground

### Strain potential energy and springs

14. The graph below describes the behaviour of three springs as known weights are suspended from one end.

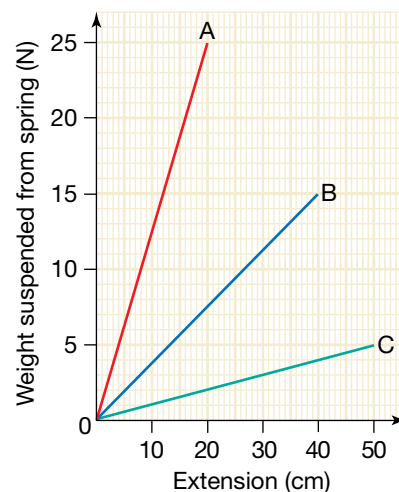

- (a) What is the force applied by spring A to a 1.0 kg mass suspended from one end?
- (b) What is the spring constant of spring B?
- (c) Which spring has the greatest stiffness?
- (d) How much work is done by a 500 g mass on spring C to extend it fully?
- (e) Which spring has the greatest strain energy at maximum extension?

**15.** The ancient Egyptians relied on knowledge of the physics of energy transformations to build the Great Pyramids at Giza. They used ramps to push limestone blocks with an average mass of 2300 kg to heights of almost 150 m. The ramps were sloped at about  $10^\circ$  to the horizontal. Friction was reduced by pumping water onto the ramps.

- (a) How much work would have to be done to lift an average limestone block vertically through a height of 150 m?
- (b) How much work would have been done to push an average limestone block to the same height along a ramp inclined at  $10^\circ$  to the horizontal? Unfortunately, you will have to assume that friction is negligible.

**16.** A weightlifter raises a barbell of mass 150 kg vertically through a height of 1.2 m.

- (a) Sketch a graph of gravitational field strength versus height of the barbell.
- (b) Use the graph to determine the change in gravitational potential energy of the barbell.
- (c) How much work did the weightlifter do on the barbell?

**17.** A crane drops a 1600 kg car from a height of 8.0 m onto the ground. At the same time, a cricket ball of mass 160 g is dropped from the same height. What is the value of the ratio:

- (a)  $\frac{\text{initial gravitational potential energy of car}}{\text{initial gravitational potential energy of cricket ball}}$
- (b)  $\frac{\text{landing kinetic energy of car}}{\text{landing kinetic energy of cricket ball}}$
- (c)  $\frac{\text{landing speed of car}}{\text{landing speed of cricket ball}}$

**18.** Angela rides a toboggan down a slope inclined at  $30^\circ$  to the horizontal. She starts from rest and rides a distance of 25 m down the slope. Angela and her toboggan have a combined mass of 60 kg.

- (a) How much work is done on Angela by the force of gravity?
- (b) If friction is negligible, what would her speed be at the end of her ride?
- (c) How much work is done on Angela by the normal reaction?
- (d) In reality, the frictional force on Angela is not negligible. Her speed at the end of her ride is measured to be  $7.2 \text{ m s}^{-1}$ . What is the magnitude of the frictional force?

**19.** The graph in figure (a) below shows how the restoring force of a spring changes as it is compressed. A 2.5 kg mass is pushed against the spring so that its length is 5.0 cm and then released. Friction can be assumed to be negligible.

- (a) How much energy is stored in the spring?
- (b) What will be the speed of the mass when the spring returns to its original length of 20 cm?
- (c) What is the spring constant of the spring?

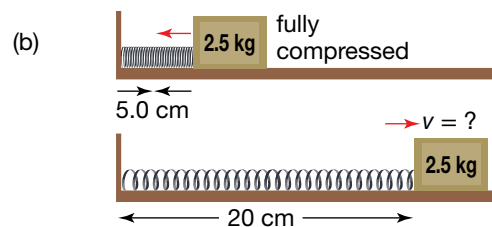
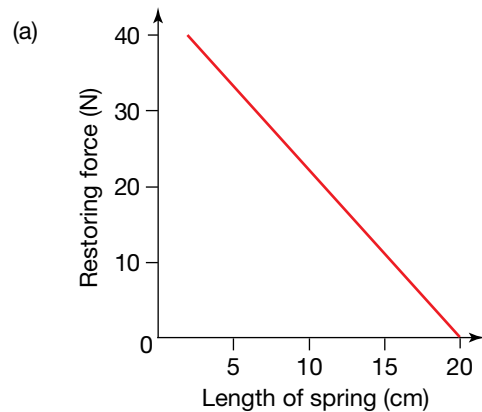

**20.** The following graph shows how the force applied by the rubber bumper at the front of a 450 kg dodgem car changes as it is compressed during factory testing.

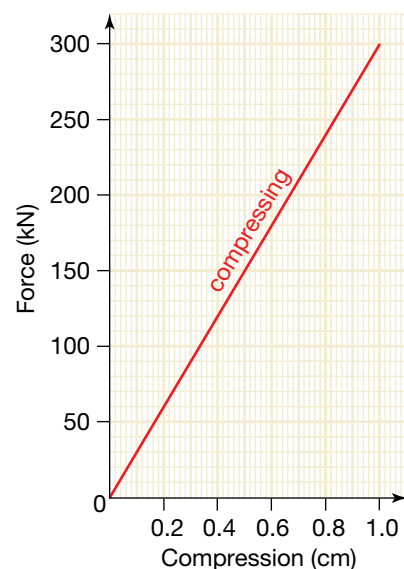

- (a) If the dodgem car collides head on with a solid wall at a speed of  $2.0 \text{ m s}^{-1}$ , what will be the maximum compression of the front rubber bumper?
- (b) How much work is done on the dodgem car by the rubber bumper as it is compressed?
- (c) If the rubber bumper obeys Hooke's Law, with what speed will the dodgem car rebound from the wall?

### Elastic and inelastic collisions

21. Three springs, each obeying Hooke's Law, are hidden in a container without a lid. Weights are added to the arrangement of springs and a graph of applied weight versus compression is drawn. The resulting graph is shown below.

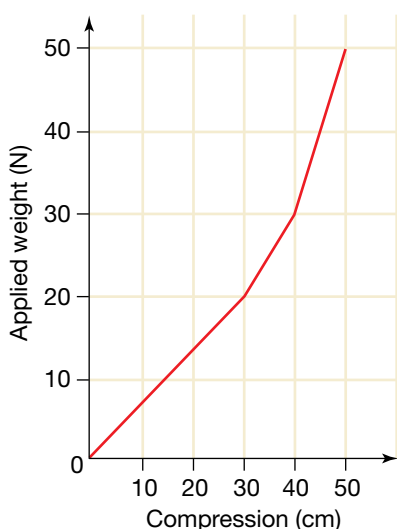

- (a) Describe how the three springs are arranged.
  - (b) Determine the spring constant of the longest spring.
  - (c) What is the spring constant of the shortest spring?
22. Consider a tennis ball that has been dropped vertically onto a hard surface.
- (a) Is the collision of the falling tennis ball with the ground elastic?
  - (b) How do you know?
  - (c) Is momentum conserved during this collision?
23. Consider a collision between two cars on an icy intersection where road friction is insignificant. Assume that the cars bounce off each other.
- (a) How do you know without performing any calculations that the collision is not elastic?
  - (b) Is momentum conserved in such a collision?
24. Two cars of equal mass and travelling in opposite directions on a wet and slippery road collide and lock together after impact. Neither car brakes before the collision. The tangled wreck moves off in an easterly direction at  $5.0 \text{ m s}^{-1}$  immediately after the collision. If one car was travelling due west at  $20 \text{ m s}^{-1}$  immediately before the collision:
- (a) what was the velocity of the other car?
  - (b) what fraction of the initial kinetic energy was 'conserved' during the collision?
25. Two cars of equal mass and travelling in opposite directions with equal speeds on a wet and slippery road collide head on.
- (a) If the vehicles lock together on impact, what is the speed of the tangled wreck after the collision?
  - (b) If both vehicles were fitted with rubber bumpers so that the collision was perfectly elastic, what would be the final speed of each vehicle if their initial speed was  $60 \text{ km h}^{-1}$ ?
26. A 60 kg bungee-jumper falls from a bridge 50 m above a deep river. The length of the bungee cord when it is not under tension is 30 m. Calculate:
- (a) the kinetic energy of the bungee-jumper at the instant that the cord begins to stretch beyond its natural length
  - (b) the strain energy of the bungee cord at the instant that the tip of the jumper's head touches the water. (Her head just makes contact with the water before she is pulled upward by the cord.) The height of the bungee-jumper is 170 cm.
27. A white billiard ball of mass 200 g moving with a velocity of  $2.0 \text{ m s}^{-1}$  due north strikes a stationary red billiard ball of the same mass. The red billiard ball moves off with a velocity of  $1.7 \text{ m s}^{-1}$  due north.
- (a) What is the final velocity of the white billiard ball?
  - (b) What percentage of the initial kinetic energy is returned to the system of the two billiard balls after the collision?
  - (c) A billiard player claims that he can make the same stationary red ball move off with a speed of  $2.5 \text{ m s}^{-1}$  when the same white ball strikes it with a speed of  $2.0 \text{ m s}^{-1}$ . When challenged, he responded that according to the Law of Conservation of Momentum, the white ball would rebound with a speed of  $0.5 \text{ m s}^{-1}$ .
    - (i) Show that the player's claim is consistent with the Law of Conservation of Momentum.
    - (ii) Explain, using calculations, why the player's claim is not correct — even though it is consistent with the Law of Conservation of Momentum.
28. In an elastic collision between two objects of mass  $m_1$  and  $m_2$ , show that the speed of approach ( $u_2 - u_1$ ) is equal to the speed of separation ( $v_2 + v_1$ ). The symbols  $u_1$ ,  $u_2$ ,  $v_1$  and  $v_2$  each represent speeds, not velocities.

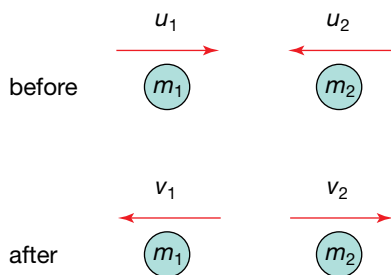

### Impulse and momentum

29. A 200 g billiard ball strikes the side of the table at right angles to its edge at a speed of  $1.5 \text{ m s}^{-1}$  and rebounds in the opposite direction with a speed of  $1.2 \text{ m s}^{-1}$ . The billiard ball is in contact with the table for 0.10 s. Assume that the frictional force on the ball is negligible.
- What is the net force applied to the billiard ball?
  - What is the impulse on the billiard ball?
  - According to Newton's Third Law of Motion, the billiard ball applies a force on the edge of the table equal and opposite to the force that the edge of the table applies to the billiard ball. Does the table move? Explain your answer.
30. When a bullet is fired from a rigidly held rifle, the force exerted by the rifle on the bullet is equal and opposite to the force exerted by the bullet on the rifle.
- Explain why the bullet accelerates while the rigidly held rifle does not.
  - In most cases when a rifle is fired, the shooter's shoulder moves back as the rifle recoils. If a 4.0 kg rifle fires a 20 g bullet with an initial speed of  $300 \text{ m s}^{-1}$ , what is the initial recoil speed of the rifle?
31. The graph below shows how the net force on an object of mass 2.5 kg changes with time.

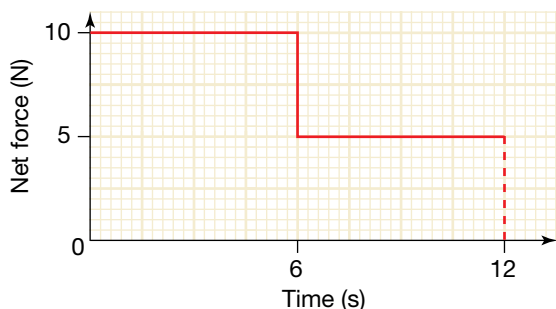

- Calculate the change in momentum of the object during the first 6.0 s.
  - If the object was initially at rest, what is its momentum after 12 s?
  - Draw a graph of velocity versus time for the object, assuming that it was initially at rest.
32. Use the ideas presented in this chapter to explain why:
- the dashboards of cars are padded
  - cars are deliberately designed to crumple at the front and rear
  - the compulsory wearing of bicycle helmets has dramatically reduced the number of serious head injuries in bicycle accidents.
- A single answer (rather than three separate answers) is acceptable.
33. A car travelling at  $50 \text{ km h}^{-1}$  ( $14 \text{ m s}^{-1}$ ) collides with a concrete wall. The front crumple zone of the car folds, allowing the car to come to a complete halt over a distance of 50 cm. The driver is wearing a properly fitted seatbelt, but the front seat passenger is unrestrained. The head of the front seat passenger strikes the dashboard and stops over a distance of 2.5 cm. The restrained driver comes to rest over the same time and distance as the whole car. The driver and front seat passenger each have a mass of 70 kg.
- Calculate:
    - the impulse on the driver
    - the impulse on the front seat passenger
    - the average acceleration of the driver during the car's impact with the concrete wall
    - the average acceleration of the passenger's head during its impact with the dashboard.
  - Express your answers to (iii) and (iv) in the number of  $g$ s to which each person is subjected. The number of  $g$ s is the multiple of the magnitude of acceleration due to gravity to which an object is exposed.
  - Write a paragraph explaining how seatbelts reduce the likelihood of death or serious injury in the event of a front-end collision.

The velocity of a yacht can be measured relative to wind, land, water or other yachts, and all of these measurements can be different.



### REMEMBER

Before beginning this chapter, you should be able to:

- calculate average speed using  $v = \frac{d}{t}$
- convert between different units of speed and velocity
- use Newton's laws of motion to analyse movement
- use the concept of half-life to describe decay rates of particles
- understand that fusion of hydrogen is the source of the Sun's energy
- calculate kinetic energy using  $E = \frac{1}{2}mv^2$ .

### KEY IDEAS

After completing this chapter, you should be able to:

- recognise that velocity, time, distance, mass and energy are relative and depend on the reference frame of the observer
- understand what is meant by frame of reference and inertial frame of reference
- define the principle of relativity as the condition that the laws of physics are the same in all inertial reference frames
- understand that special relativity established the speed of light as an invariant quantity
- describe Maxwell's observation that the speed of electromagnetic waves depends only on the electrical and magnetic properties of the medium they pass through
- describe Einstein's two postulates for the Special Theory of Relativity
- recognise and describe proper time and proper length
- calculate time dilation and length contraction for moving reference frames
- explain how muons can reach the surface of the Earth despite their short half-lives
- discuss the equivalence of mass and energy through the equation  $E = mc^2$
- calculate relativistic kinetic energies
- explain the relationship between the Sun's energy output and its mass loss.

## study on

Unit 3

Relativity

AOS 3

Concept summary  
and practice

Topic 5

questions

Concept 2

A quantity is **relative** when it has different values for different observers.



Albert Einstein (1879–1955)



A speed limit is the maximum allowed speed relative to the road.

## What is relativity?

The speed of an object depends on the **relative** motion of the observer. So do the object's time, kinetic energy, length and mass; that is, these properties are relative rather than fixed. Albert Einstein discovered that some of the physical properties that people assumed to be fixed for all observers actually depend on the observers' motions. But not everything is relative. The laws of physics and the speed of light are the same for all observers. Major developments in physics have come about at times when physicists such as Galileo and Einstein developed a clearer understanding of what is relative and what is not.

Albert Einstein (1879–1955) is one of the most famous figures in history, largely due to his work on relativity. Einstein did not invent the idea of relativity — it dates back to Galileo — but he brought it into line with nineteenth-century developments in the understanding of light and electricity, leading to some striking changes in how physicists viewed the world. In this chapter, we look at the first revolution in relativity, then explore some of the ideas of Einstein's Special Theory of Relativity.

### There is no rest

Let's start with a down-to-earth scenario. Consider a police officer pointing her radar gun at an approaching sports car from her car parked on the roadside. She measures the sports car's speed to be  $90 \text{ km h}^{-1}$ . This agrees with the speed measured by the driver of the sports car on his car's speedometer. However, another police car drives towards the sports car in the opposite direction at  $60 \text{ km h}^{-1}$ . A speed radar is also operating in this car, and it measures the speed of the sports car to be  $150 \text{ km h}^{-1}$ . So each police officer has a different measurement for the speed of the sports car. Which measurement is correct? The answer is that they are both correct — the speed measured for the car is relative to the velocity of the observer — but only the speed measured by the officer at rest on the roadside is relevant when receiving a speeding ticket.

The sports car is approaching the oncoming police car at the same rate as if the police car was parked and the sports car had a reading of  $150 \text{ km h}^{-1}$  on its speedometer. We say that the speed of the car is relative to the observer rather than being an absolute quantity, agreed on by all observers. The significance of relative speed becomes all too clear in head-on collisions. For example, you might be driving at only  $60 \text{ km h}^{-1}$ , but if you collide head-on with someone doing the same speed in the opposite direction, the impact occurs for both cars at  $120 \text{ km h}^{-1}$ !



The radar gun would measure a different speed if it was in a moving vehicle.

## study on

Unit 3

**Relative velocity**

AOS 3

Concept summary and practice questions

Topic 5

Concept 3

## study on

Unit 3

AOS 3

Topic 5

Concept 3



**See more**  
Relative velocity



Galileo Galilei (1564–1642), from a nineteenth-century engraving

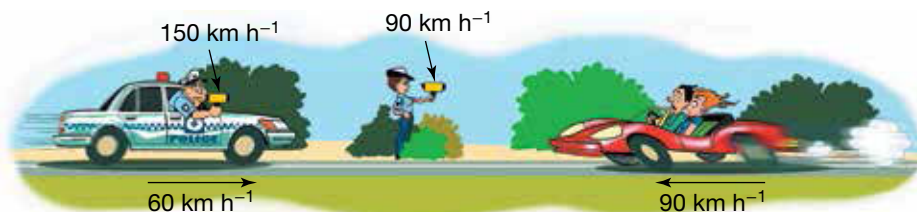

Two different measurements of the speed of a car

Relativity is about the laws of physics being meaningful for all observers. Newton's First Law of Motion states that an object will continue at constant velocity unless acted on by an unbalanced net force. The speed itself does not matter. In the example above, this law works for both of the police officers, as do the other laws of motion.

The Italian scientist Galileo Galilei (1564–1642) did not know about police cars and speed limits. His examples featured sailing ships and cannon balls, but the physics ideas were the same. In Galileo's time, much of physics was still based on ancient ideas recorded by the Greek philosopher Aristotle (384–322 BC). Aristotle taught that the Earth was stationary in the centre of the universe. Motion relative to the centre of Earth was a basis for Aristotelian physics, so a form of relativity was key to physics even before Galileo. But Galileo had to establish a new understanding of relativity before it became widely accepted that the Earth moved around the Sun.

Galileo's insight helped provide the platform for physics as we know it today, but the idea of a fixed frame of reference persisted. Following on from Galileo, Isaac Newton considered the centre of mass of the solar system to be at absolute rest. James Clerk Maxwell (1831–1879), who put forward the theory of electromagnetism, regarded the medium for electromagnetic waves (light) to be at rest. It was Einstein who let go of the concept of absolute rest, declaring that it was impossible to detect a place at absolute rest and therefore the idea had no consequence. Once again, relativity was updated to take into account the latest discoveries and enable physics to make enormous leaps of progress.

The speed (velocity) of bodies in motion is truly relative to whoever is measuring it. We will return to Einstein's advances shortly, but let's look at some more examples from Galilean relativity.



Aristotle had the Earth at rest.

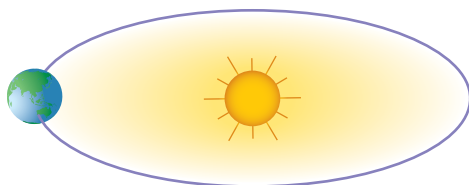

Galileo had the Sun at rest.

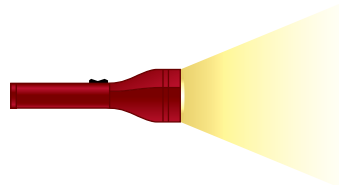

Maxwell had the aether at rest.



Einstein said it was impossible to tell if something was truly at rest.

What should we measure speed relative to?

## The principle of relativity

Consider the driver of the sports car discussed earlier. His position relative to features of the landscape he drives through is continuously changing, but



inside the car life goes on as normal. He has the same position, weight, mass and height; everything inside the car behaves just as he remembers it from when the car was parked. On a smooth road at constant speed, his passenger could pour a drink without difficulty. The effect of the bumps in the road would be indistinguishable from a situation in which the car was stationary and someone outside was rocking it.

Nothing inside a vehicle moving with constant velocity can be affected by the magnitude of the velocity. If it was, we would need to ask: which velocity? If a velocity of  $90 \text{ km h}^{-1}$  caused a passenger to have a mass of  $50 \text{ kg}$ , but a velocity of  $150 \text{ km h}^{-1}$  caused the passenger to have a mass of  $60 \text{ kg}$ , we would have a problem. The driver cannot simultaneously observe his passenger to have two different masses.

The principle of relativity is the name that physicists give to this realisation. This states that the laws of physics do not depend on the velocity of the observer. Galileo played a major role in the development of the principle of relativity, and Newton's laws of motion are fully consistent with it. Another way of describing the principle of relativity is that there is no way that anyone in the car can measure its velocity without making reference to something external to the car. The sports car driver can measure his speed relative to the two police officers mentioned above. He would measure that he is moving relative to each of them at different speeds, but he would not feel any difference. As long as the road is straight and smooth and the car is travelling at a constant speed, there is no way to detect that the car is moving at all! He could be stationary while one police car is approaching him at  $90 \text{ km h}^{-1}$  and the other at  $150 \text{ km h}^{-1}$ .

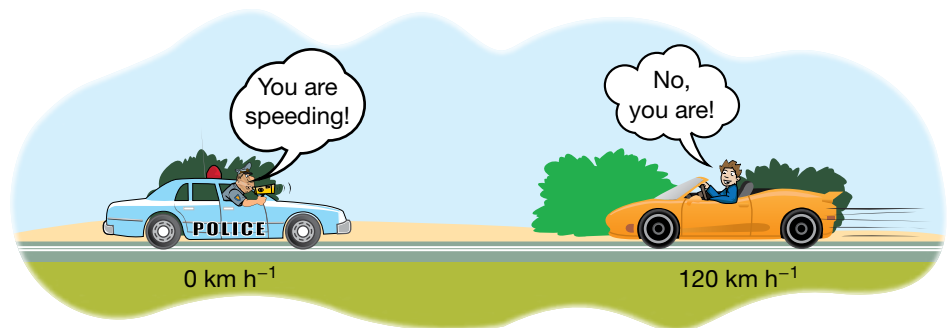

How can we tell who is actually speeding?

Even on an aeroplane travelling smoothly at  $700 \text{ km h}^{-1}$ , we feel essentially the same as we do at rest. The only giveaway is the turbulence the aircraft experiences and the change in air pressure in our ears. Neither of these effects is dependent on the forward velocity of the plane. The laws of physics are the same: you can pour your can of drink safely, walk down the aisle, and drop a pencil and notice it fall vertically to the floor just as it would if you were on the ground.

By introducing the principle of relativity, Galileo provided the necessary framework for important developments in physics. Physics builds on the premise that the universe follows some order that can be expressed as a set of physical laws. The Aristotelian ideas that were held at the time of Galileo suggested that a force is necessary to keep objects moving. This led to one of the major arguments against Earth's motion: everyone would be hurled off the Earth's surface as it hurtled through space, and the Moon would be left behind rather than remaining in orbit around Earth. Galileo's physics, including the principle of relativity, helped to explain why this argument was wrong. Forces are not required to keep objects moving, only to change their motion.

The science of Galileo and Newton was spectacularly successful: it explained the motion of everything from cannon balls to planets. Later, however, as new theories of physics developed in the nineteenth century, physicists faced the challenge of how to make everything fit together. It was not until the early twentieth century that Einstein found a way to make sense of it all.

## Examples of Galilean relativity

Here are some examples that support the Galilean principle of relativity.

1. If you are in a car stopped at the lights and another car next to yours slowly rolls past, it is difficult to tell whether you or the other car is moving if nothing but the other car is in view.
2. In IMAX and similar films, viewers can feel as though they are going on a thrilling ride, even though they are actually sitting on a fixed seat in a cinema. Theme parks enhance this effect in virtual reality rides by jolting the chairs in a way that mimics movements you would feel on a real ride. Virtual reality rides are very convincing because what you see and feel corresponds with an expected movement, and your senses do not tell you otherwise. As long as the jolts correspond with the visual effects, there is no way of telling the difference. The motion or lack of motion of the seat is irrelevant.



A virtual reality ride

3. Acceleration does not depend on the velocity of the observer. An astronaut in a spacecraft travelling through deep space with constant velocity feels weightless, regardless of the magnitude of the velocity. She moves along with the same velocity as the spacecraft, as Newton's first law would suggest. When the spacecraft accelerates due to the force of its rocket engines, the astronaut feels pushed against the back wall of the spacecraft by a force that depends on the magnitude of the acceleration. The effect of the acceleration on the astronaut is noticeable, and may even cause the astronaut to lose consciousness if it is too great.
4. When you are riding in a car with the window down, most of the wind you feel on your face is due to the motion of the car through the air. It is present

even on a still day. Only very severe winds exceed  $60 \text{ km h}^{-1}$ ; whenever you drive at greater than  $60 \text{ km h}^{-1}$ , your windscreen is saving you from gale-force winds! Similarly, it is always windy on moving boats. This is because on deck you are not as well protected from the apparent wind as you are in a car.

5. Apparent wind becomes especially significant when sailing. As the boat increases its speed, the sailor notices that he is heading more into the wind, even though neither he nor the wind has changed direction relative to the shore. This leads the sailor to change the sail setting to suit the new wind direction.

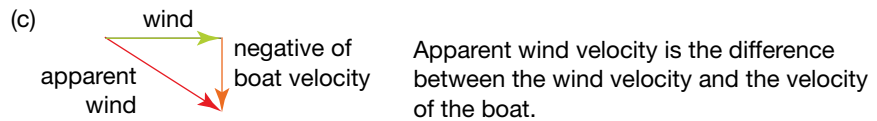
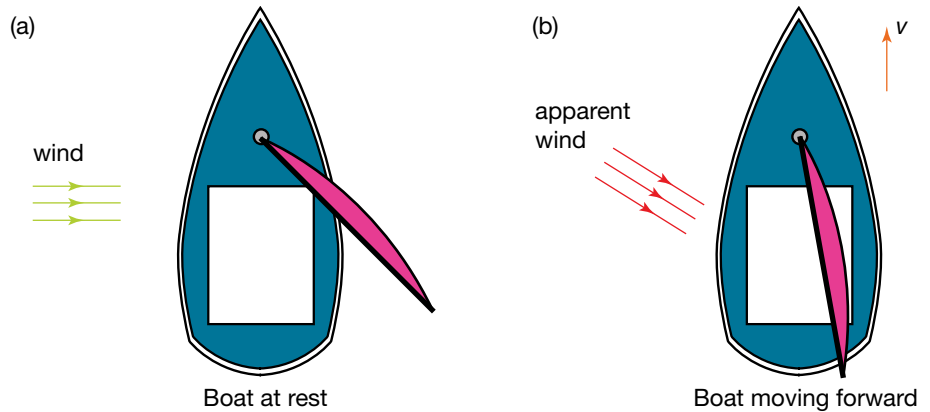

The faster the boat moves, the more the wind appears to blow from in front.

### Sample problem 3.1

Compare the following two scenarios in terms of velocity.

1. A car travelling down the highway at  $80 \text{ km h}^{-1}$  collides with a stationary car.
2. A car travelling down the highway at  $100 \text{ km h}^{-1}$  collides with a car travelling at  $20 \text{ km h}^{-1}$  in the same direction.

**Solution:** In the first scenario, the first car is travelling at  $80 \text{ km h}^{-1}$  relative to the second car.

In the second scenario, the first car is travelling at  $100 - 20 = 80 \text{ km h}^{-1}$  relative to the second car. Although the speeds relative to the road in each case are different, the relative speeds of the cars are the same and will cause similar effects on collision.

### Revision question 3.1

The key to Galilean relativity is that:

- A. acceleration
- B. velocity
- C. time
- D. mass

is relative.

## study on

### Unit 3 Events and frames

#### AOS 3

Concept summary and practice questions

#### Topic 5

#### Concept 1

## Frames of reference

To help make sense of all of the possible velocities, physicists consider frames of reference. A frame of reference involves a system of coordinates. For example, where you are sitting reading this book, you view the world through your frame of reference. You can map the position of things around you by choosing an origin (probably the point where you are), then noting where everything else is in reference to that: the window is one metre in front of you, the door is two metres behind you, and so on. Your reference frame also includes time, so you can see that the position of the window in front of you is not changing and you can therefore say its velocity is zero.

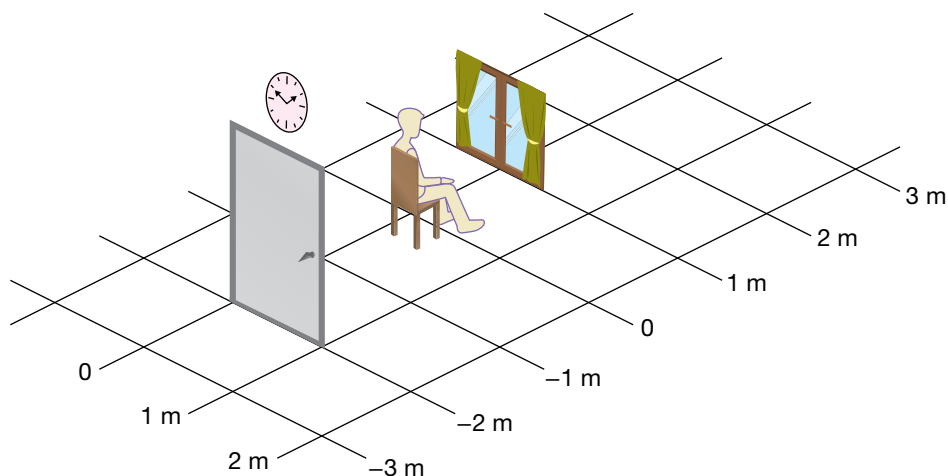

A reference frame is a set of space and time coordinates that are stationary relative to an observer.

When we say something is ‘at rest,’ we mean it is at rest in the reference frame in which we view the world. In everyday life we have a tendency to take a somewhat Aristotelian point of view and regard everything from the perspective that the Earth is at rest. For example, another student walking behind you has her own reference frame. As she walks, your position in her frame of reference is moving. However, she would probably say that she is moving past you while you are stationary, rather than saying that she is stationary while you and the rest of the room are on the move!

In many situations, considering the Earth to be at rest is a convenient assumption. In more complex examples of motion, such as sports events, car accidents involving two moving vehicles, or the motions of the Solar System, it can be useful to choose alternative frames of reference.

In classical physics, the differences between frames of reference are their motion and position. (‘Classical physics,’ simply put, is the physics that predated Einstein’s discoveries leading to the laws of relativity and quantum mechanics.) In other words, position and speed are relative in classical physics. For example, I might record an object to have a different position than you would (it might be 3 metres in front of me but 4 metres behind you), and I might also record it as having a different speed (maybe it is stationary in my frame of reference but approaching you at  $2 \text{ m s}^{-1}$ ). The position and speed are dependent on the observer. However, in classical physics all observers can agree on what 3 metres and  $2 \text{ m s}^{-1}$  are. The rulers in my frame of reference are the same as the ones I see in yours, and the clocks in my frame of reference tick at the same rate as I measure those ticking in yours. Time and space are seen as absolute in the classical physics established by Galileo, Newton and the other early physicists.

Reference frames that are not accelerating are called **inertial reference frames**.

Frames of reference that are not accelerating are called **inertial reference frames**. An inertial reference frame moves in a straight line at a constant speed relative to other inertial reference frames.

### Sample problem 3.2

Consider the reference frame in which a spacecraft is initially at rest (reference frame A). Astronaut Axel is in the spacecraft and he fires its rockets for 10 s, achieving a final velocity of  $100 \text{ m s}^{-1}$ . Show that the acceleration of the rocket does not depend on the reference frame.

**Solution:** We will show this by determining what the acceleration of the spacecraft is in reference frame A and randomly choosing another inertial reference frame, B, to see if the acceleration is the same.

According to the measurements made in A, the rocket accelerated for 10 s at:

$$\begin{aligned} a &= \frac{\Delta v}{t} \\ &= \frac{100 \text{ m s}^{-1} - 0 \text{ m s}^{-1}}{10 \text{ s}} \\ &= 10 \text{ m s}^{-2}. \end{aligned}$$

Axel would feel a force towards the rear of the spacecraft similar in magnitude to his weight on Earth.

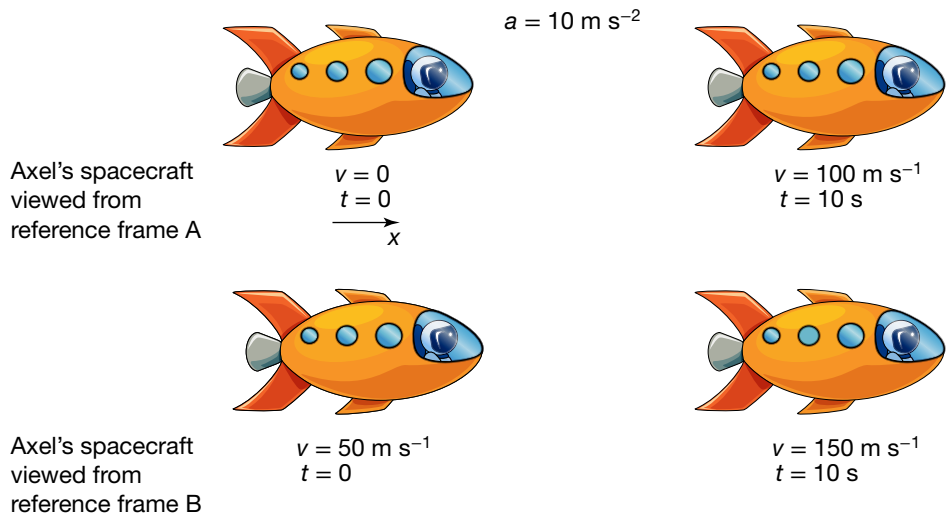

Now we choose a different reference frame. Effie is in reference frame B in another spacecraft, moving at  $50 \text{ m s}^{-1}$  relative to A. She also measures the acceleration of Axel's spacecraft from her reference frame. Effie measures the velocity of Axel's spacecraft to change from  $50 \text{ m s}^{-1}$  to  $(50 + 100) \text{ m s}^{-1}$  in 10 s. From B:

$$\begin{aligned} a &= \frac{\Delta v}{t} \\ &= \frac{150 \text{ m s}^{-1} - 50 \text{ m s}^{-1}}{10 \text{ s}} \\ &= 10 \text{ m s}^{-2}. \end{aligned}$$

The acceleration is the same whether it is measured from frame A or frame B. We observe that it will still be  $10 \text{ m s}^{-2}$  regardless of the speed of the reference frame.

---

An **invariant** quantity is a quantity that has the same value in all reference frames.

An **invariant** quantity is a quantity that has the same value in all reference frames. In classical physics, mass is the same in all reference frames, so all observers will observe that Newton's second law holds. In sample problem 3.2, all observers would agree on the forces acting on the astronauts. Unlike velocity, acceleration in Galilean relativity does not depend on the motion of the frame of reference; it is also invariant.

It is interesting to consider the motion of Axel's spacecraft as viewed by Effie in reference frame B. Reference frame B is in an inertial reference frame as it is not accelerating. Axel, however, looks back at Effie and sees her falling behind at an increasing rate. Is it Axel or Effie that is accelerating? The answer is clear to them: the force experienced by Axel is not felt by Effie. The acceleration can be measured by this force without any reference to the relative motions of other objects; an object's velocity cannot.

### Revision question 3.2

- (a) Explain what is meant by the statement 'speed is relative to the frame of reference'.
- (b) By referring to Newton's laws of motion, explain why it is important for acceleration to be invariant, but velocity can be relative.
- (c) Explain why the principle of relativity is so important to physics.

## Electromagnetism brings new challenges

Galilean relativity seemed to work well for the motion of massive bodies, but by the nineteenth century physicists were learning much more about other physical phenomena.

James Clerk Maxwell's theory of electromagnetism drew together the key findings of electricity and magnetism to completely describe the behaviour of electric and magnetic fields in a set of four equations. One of the outcomes of this was an understanding of electromagnetic waves. The equations dictated the speed of these waves, and Maxwell noticed that the speed was the same as what had been measured for light. He suggested that light was an electromagnetic wave and predicted the existence of waves with other wavelengths that were soon discovered, such as radio waves. A medium for these fields and waves was proposed, called the luminiferous aether. The speed of light,  $c$ , was the speed of light relative to this aether.

Understanding electromagnetic phenomena was the foundation for Einstein's special relativity. In particular, the physicists of the nineteenth century, such as Michael Faraday, knew that they could induce a current in a wire by moving a magnet near the wire. They also knew that if they moved a wire through a magnetic field, a current would be induced in the wire. They saw these as two separate phenomena.

Imagine this: two students are in different Physics classes. Annabel has learned in her class that electrons moving in a magnetic field experience a force perpendicular to their direction of motion and in proportion to the speed. Her friend Nicky has learned in her class that a current is induced in a loop of wire when the magnetic flux through the wire changes. Are these two different phenomena? Because they have also learned about the principle of relativity, Annabel and Nicky have doubts. They get together after class to perform experiments. The force depends on the speed. Annabel holds a stationary loop of conducting wire. Nicky moves the north pole of a magnet towards the loop, and they notice that a current is present in the wire as she does this.

Annabel is stationary

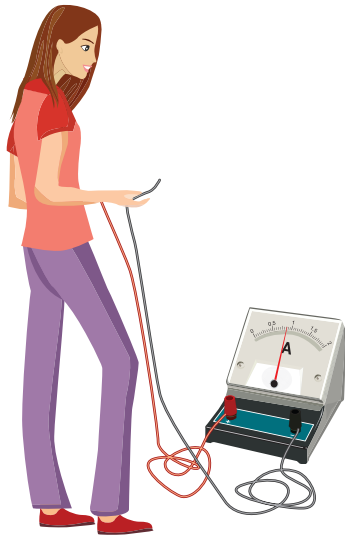

Nicky moves



Nicky says that this is consistent with what she has learned. The conclusion is that a current is induced by a changing magnetic field. Then Nicky holds the magnet still so that the magnetic field is not changing. Annabel moves her loop of wire towards Nicky's magnet. Annabel states that the result agrees with what she learned in class — that electrons and other charged particles experience a force when moving in a magnetic field.

Einstein realised that there was only one phenomenon at work here. Both experiments are doing exactly the same thing, and it is only the relative speeds of the coil and the magnet that are important. This may seem obvious, but to make this jump it was necessary to discard the idea that the electric and magnetic fields depended on the luminiferous aether. It was the relative motion that was important, not whether the magnet or charge was moving through the aether.

Annabel moves



Nicky is stationary



Before Einstein's realisation, the understanding was that if light moves through the aether, then the Earth must also be moving through the aether. Changes in the speed of light as the Earth orbits the Sun should be detectable. Maxwell predicted that electromagnetic waves would behave like sound and water waves, in that the speed of electromagnetic waves in the medium would not depend on the motion of the source or the detector through the medium.

To understand the significance of this aether, consider the sound produced by a jet plane. When the plane is stationary on the runway preparing for takeoff, the sound travels away from the plane at the speed of sound in air, about  $340 \text{ m s}^{-1}$ . When the plane is flying at a constant speed, say  $200 \text{ m s}^{-1}$ , the speed of sound is still  $340 \text{ m s}^{-1}$  in the air. However, to find the speed relative to the reference frame of the plane, we must subtract the speed of the plane relative to the air. From this we find that the sound is travelling at:

$$340 - 200 = 140 \text{ m s}^{-1} \text{ in the forward direction relative to the plane}$$

$$340 - (-200) = 540 \text{ m s}^{-1} \text{ in the backward direction relative to the plane.}$$

An experiment in electromagnetism

(a) Velocity of sound relative to plane  $v = 200 \text{ m s}^{-1}$

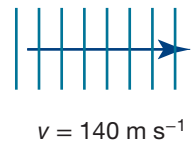
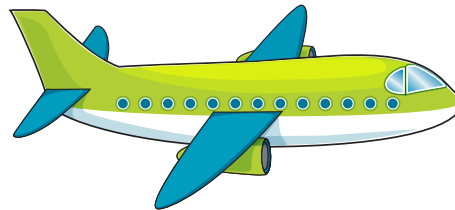
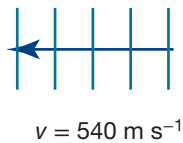

(b) Velocity of sound relative to air  $v = 0 \text{ m s}^{-1}$

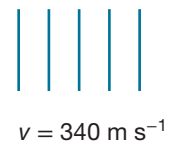
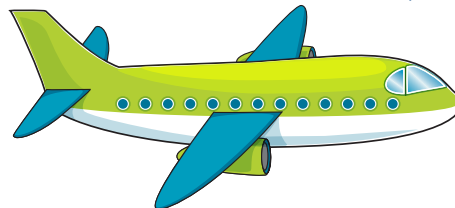
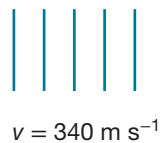

Sound moving away from a plane

In this example we could measure the speed of the plane through the air by knowing the speed of sound in air ( $340 \text{ m s}^{-1}$ ) and measuring the speed of a sound sent from the back of the plane to the front ( $140 \text{ m s}^{-1}$ ) in the reference frame of the plane. As long as the plane is flying straight, we could infer the speed of the plane relative to the air by setting the forward direction as positive and subtracting the velocities:

$$340 - 140 = 200 \text{ m s}^{-1}.$$

The speed of the plane has been measured relative to an external reference frame, that of the air, and therefore this example has not violated Galilean relativity. As light had been shown to travel in waves, scientists felt they should be able to measure Earth's speed through the aether in the same way.

### Sample problem 3.3

Explain how Maxwell's concept of electromagnetic waves such as light challenged the Galilean principle of relativity.

**Solution:** The principle of relativity states that the laws of physics hold true in all inertial reference frames. Maxwell predicted that the speed of light was constant relative to the aether. Different explanations were required for electromagnetic phenomena depending on the speed of magnets and charges through the aether.

### Revision question 3.3

Assuming that electromagnetic waves travel at  $c$  relative to the aether, determine the speed of light shining from the rear of a spacecraft moving at half the speed of light relative to the aether according to Kirsten, who is on board the spacecraft.

### eBook plus

#### eLesson

Michelson–Morley experiment  
eles-2561

## The Michelson–Morley experiment

In 1887, Albert Michelson and Edward Morley devised a method of using interference effects to detect slight changes in time taken for light to travel through different paths in their apparatus. As with sound travelling from the front and rear of a plane through the air, the light was expected to take different amounts of time to travel in different directions through the luminiferous aether as the Earth moved through it. Much to their astonishment, the predicted change in the interference pattern was not observed. It was as though the speed of light was unaffected by the motion of the reference frame of its observer or its source!

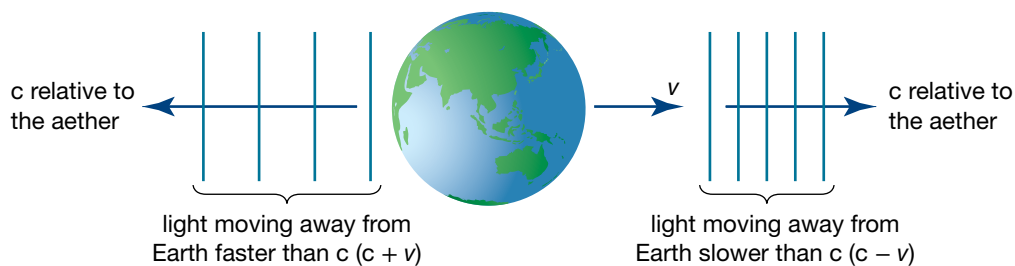

The idea behind the Michelson–Morley experiment

### study on

Unit 3

**Einstein's two postulates**

AOS 3

Concept summary and practice questions

Topic 5

Concept 4

## Einstein's two postulates of special relativity

Physicists tried all sorts of experiments to detect the motion of Earth through the luminiferous aether, and they attempted to interpret the data in ways that would match the behaviour of light with what they expected would happen. Their attempts were unsuccessful.



Einstein managed to restore order to our understanding of the universe. While others suspected the new theory of electromagnetism to be wrong, Einstein took apart the established theory of Newtonian mechanics, even though its success had given physicists reason to believe in relativity in the first place. Einstein dared to see what would happen if he embraced the results of the Maxwell equations and the experiments with light, and accepted that the speed of light was invariant. The results were surprising and shocking, but this bold insight helped usher in the modern understanding of physics.

Einstein agreed with Galileo that the laws of physics must be the same for all observers, but he added a second requirement: that the speed of light in a vacuum is the same for all observers. The speed of light is not relative, as had been expected by those who went before him, but invariant. He set these two principles down as requirements for development of theoretical physics. They are known as Einstein's two postulates of special relativity:

1. The laws of physics are the same in all inertial (non-accelerated) frames of reference.
2. The speed of light has a constant value for all observers regardless of their motion or the motion of the source.

The physics based on these postulates has become known as special relativity. It is 'special' because it deals with the special case where there is no gravity. To deal with gravity, Einstein went on to formulate his theory of general relativity, but that is beyond the scope of this course.

Einstein's postulates were radical. The consequence of his insistence that physics be based on these two postulates was that ideas that had been taken for granted for centuries were thrown out. As well as the removal of the luminiferous aether, the intuitive notions that time passed at the same rate for everyone, that two simultaneous events would be simultaneous for all observers, and that distance and mass are the same for all observers had to be discarded.

Einstein's work explained why the velocity of Earth could not be detected. His first postulate implied that there is no experiment that can be done on Earth to measure the speed of Earth. We must take an external reference point and measure the speed of Earth relative to that point in order for the speed of Earth to have any meaning. With his second postulate, Einstein also declared that it does not matter which direction the Michelson–Morley apparatus was pointing in; the light would still travel at the same speed. No change in the interference pattern should be detected when the apparatus was rotated.

### Sample problem 3.4

How do Einstein's postulates differ from the physics that preceded him?

**Solution:** Firstly, the principle of relativity is applied to all laws of physics, not just the mechanics of Galileo and Newton.

Secondly, the speed of light is constant for all observers. Before Einstein, the speed of light was assumed to be relative to its medium, the luminiferous aether.

### Revision question 3.4

Einstein realised that something that had been regarded as relative was actually invariant. As a result of this, quantities that had been regarded as invariant now had to be regarded as relative. What did he find to be invariant and what relative?

## Broadening our horizons

Why did scientists before Einstein (and most of us after Einstein) not notice the effects of light speed being invariant? Newton's laws provided a very good approximation for the world experienced by people before the twentieth century.

*Note:* When considering speeds at a significant fraction of the speed of light, it is easier to use the speed of light as the unit. For example, instead of  $1.5 \times 10^8 \text{ m s}^{-1}$ , a physicist can simply write  $0.5c$ .

By the beginning of the twentieth century, however, physicists were able to take measurements with amazing accuracy. They were also discovering new particles, such as electrons, that could travel at incredible speeds. Indeed, these speeds were completely outside the realm of human experience. Light travels at  $c = 3 \times 10^8 \text{ m s}^{-1}$  or 300 000 km per second. (To be precise,  $c = 299\,792\,458 \text{ m s}^{-1}$ .) At this speed, light covers the distance to the Moon in roughly 1.3 seconds!

### Sample problem 3.5

To get a sense of how fast light travels, Andrei considers how long it would take to accelerate from rest to a tenth of this great speed at the familiar rate of  $9.8 \text{ m s}^{-2}$  — the acceleration of an object in free fall near the surface of Earth.

**Solution:**  $u = 0 \text{ m s}^{-1}$ ,  $v = 0.1c = 3 \times 10^7 \text{ m s}^{-1}$ ,  $a = 9.8 \text{ m s}^{-2}$ ,  $t = ?$

$$v = u + at$$

$$t = \frac{v - u}{a}$$

$$= \frac{3 \times 10^7}{9.8}$$

$$= 3.06 \times 10^6 \text{ seconds}$$

$$= 35.4 \text{ days}$$

It would take more than 35 days to achieve a speed of  $0.1c$ ! (This is the fastest speed for which use of Newtonian kinematics still gives a reasonable approximation.)

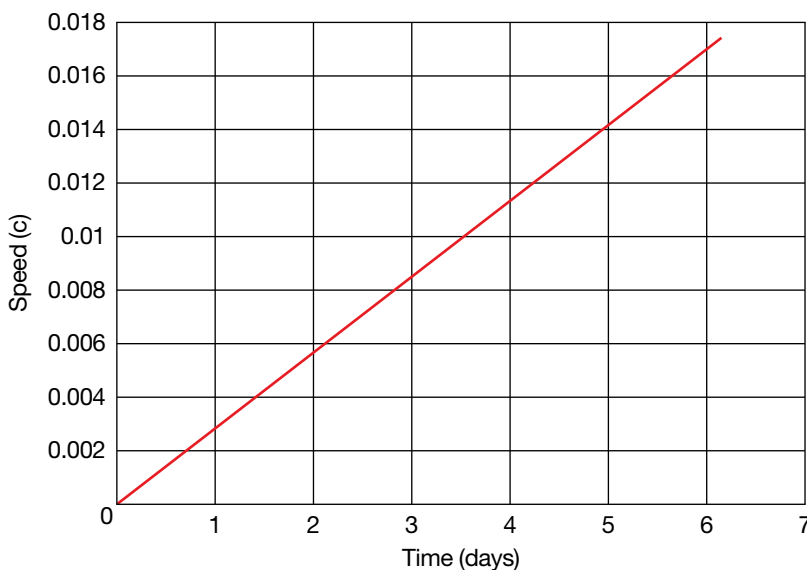

This graph shows how speed as a fraction of  $c$  increases over time at an acceleration of  $9.8 \text{ m s}^{-2}$ .

### Revision question 3.5

With an acceleration of  $9.8 \text{ m s}^{-2}$ , occupants of a spacecraft in deep space would reassuringly feel the same weight they feel on Earth. What would happen to the astronauts if the acceleration of the spacecraft was much greater to enable faster space travel?

Light speed really is beyond our normal experience! Maybe Einstein's predictions would not be so surprising if we had more direct experience of objects travelling at great speeds, but as it is they seem very strange.

### AS A MATTER OF FACT

The distance light travels in a year is known as a light-year. Even on Earth, we now measure distance in terms of the speed of light. One metre is defined as the distance light travels in exactly  $\frac{1}{c} = \frac{1}{299\,792\,458}$  of a second.

## The speed of light is constant

This simple statement of Einstein's second postulate may not seem remarkable. To highlight what it means, we will again compare light with sound. In the nineteenth century, sound and light were thought to have a lot in common, because they both exhibited similar wavelike behaviours, such as diffraction and interference. However, sound is a disturbance of a medium, whereas light does not require any medium at all. Sound has a speed that is relative to its medium. If the source of the sound is moving through the medium, then the speed of the sound relative to the source is different to the speed of sound relative to the medium. Its speed can be different again from the reference frame of the observer.

Einstein was saying there is no medium for light, so the concept of the speed of light relative to its medium is not meaningful. Light always moves away from its source at  $299\,792\,458\text{ m s}^{-1}$  and always meets its observer at  $299\,792\,458\text{ m s}^{-1}$ , no matter what the relative speeds of the observer and the source. Even if the Earth were hurtling along its orbit at  $0.9c$ , the result of the Michelson–Morley experiment would have been the same.

As an example, consider a spacecraft in the distant future hurtling towards Earth at  $0.5c$ . The astronaut sends out a radio message to alert Earth of his impending visit. (Radio waves, as part of the electromagnetic spectrum, have the same speed as visible light.) He notices that, in agreement with the Michelson–Morley measurements of centuries before, the radio waves move away from the spacecraft at  $c$ . With what speed do they hit the Earth? Relative velocity, as treated by Galileo, insists that as the spacecraft already has a speed of  $0.5c$  relative to the Earth, then the radio waves must strike the Earth at  $1.5c$ . However, this does not happen. The radio waves travel at  $c$  regardless of the motion of the source and the receiver.

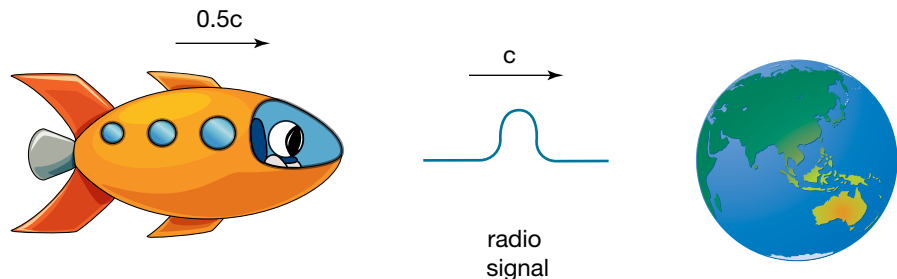

A spacecraft approaching Earth at  $0.5c$ . The radio signal is travelling at  $c$  relative to both Earth and the spacecraft!

This concept was very difficult for physicists to deal with, and many resisted Einstein's ideas. But the evidence is irrefutable. Newtonian physics works as a very good approximation only for velocities much less than  $c$ . The faster

something moves, the more obvious it is that the Newtonian world view does not match reality. It was not until the twentieth century that scientists dealt with objects (such as cosmic rays) moving at great speeds. Satellites in orbit need to be programmed to follow Einstein, rather than Newton, if they are to provide accurate data.

## Space–time diagrams

In 1908, Hermann Minkowski invented a useful method of depicting situations similar to the spacecraft scenario described above. His diagrams are like distance–time graphs with the axes switched around. However, they differ from time–distance graphs in an important way. When reading these diagrams, the markings on the scales for time and position are only correct for the reference frame in which the axes are stationary.

### Sample problem 3.6

Light reflecting off planet A radiates in all directions at  $c$  so that after one year, the light that left the planet forms a circle one light-year in radius. Another planet, B, passes planet A at great speed, just missing it. Light from B's surface also leaves at  $c$ , according to the second postulate, forming a circle around it. How can both planets be at the centre of their light circles as the postulates demand?

**Solution:** Draw Minkowski diagrams for each planet. Diagram (a) shows the situation for planets A and B from the reference frame of the planet, with the planet at the centre — the labels refer to planet A, but the diagram is the same for both planets. The light radiates in all directions at the same rate, and the diagram shows where the light in one direction and the opposite direction would be after one year.

Diagram (b) shows what is happening on B according to observers on A. The light moving out behind the moving planet reaches the one-light-year distance sooner than the light moving out from the front! But we know that planet B is at the centre of this light circle. The way to achieve this is to move away from absolute space and time and understand that these are relative to the observer. When we do this, we see that it is possible for planet B to be at the centre of the light circle. However, this requires that A and B disagree about when two events occur. According to planet A, the different sides of the light circle reach the light-year radius at different times, but from planet B this must occur simultaneously.

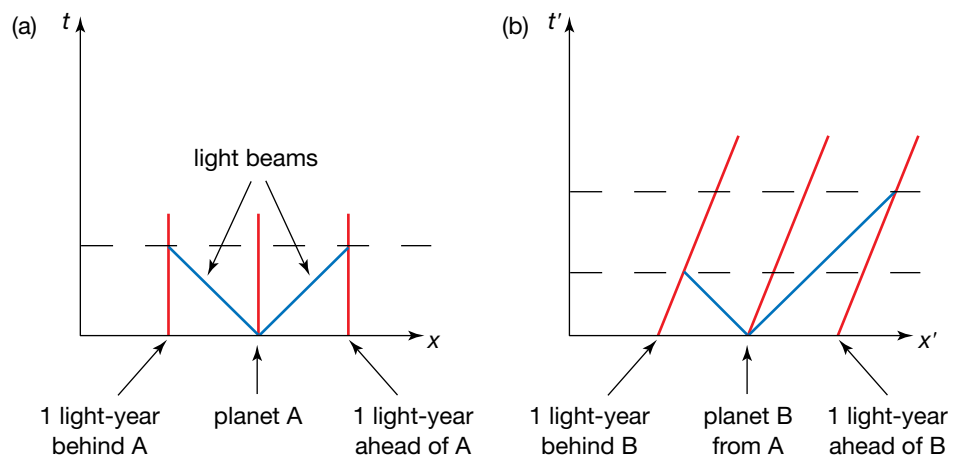

Events that are simultaneous in one reference frame are not simultaneous in another.

### Revision question 3.6

State whether the simultaneity of events is invariant or relative in:

- (a) classical physics
- (b) special relativity.

#### study on

Unit 3

**Time dilation**

AOS 3

Concept summary and practice

Topic 5

questions

Concept 5

**Thought experiments** (also known as gedanken experiments) are imaginary scenarios designed to explore what the laws of physics predict would happen.

## Time dilation

The passing of time can be measured in many ways, including using the position of the Sun in the sky, the position of hands on a watch, the changing of the seasons, and the signs of a person ageing. Galileo is known to have made use of the beat of his pulse, the swinging of a pendulum and the dripping of water. As already stated, Newtonian physics assumed that each of these clocks ticked at the same rate regardless of who was observing them. However, the theory of relativity shows that this assumption that time is absolute is actually wrong. This error becomes apparent when the motion of the clock relative to the observer approaches the speed of light.

Consider a simple clock consisting of two mirrors, A and B, with light reflecting back and forth between them. This is an unusual clock, but it is very useful for illustrating how time is affected by relativity. Experiments that involve pursuing an idea on paper without actually performing the experiment are common in explanations of relativity. They are known as **thought experiments**.

Let the separation of the mirrors be  $L$ . The time for the pulse of light to pass from mirror A to mirror B and back is calculated in the conventional way:

$$c = \frac{2L}{t_0}$$

$$t_0 = \frac{2L}{c}$$

where  $t_0$  is the time for light to travel from A to B and back, as measured in the frame of reference in which the clock is at rest. We will define this time,  $t_0$ , to be one tick of the clock. In this case, the position of the clock does not change in the frame of reference. The passing of time can be indicated by two events separated by time but not by space — the event of the photon of light first being at A and the event of the photon being back at A.

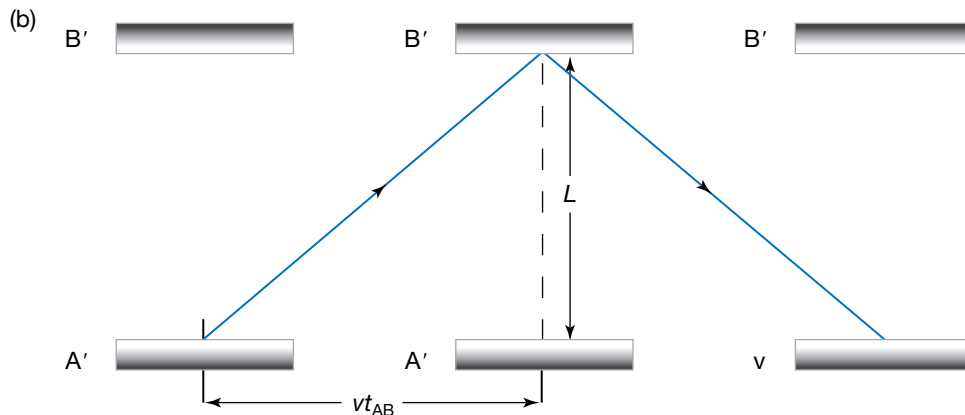
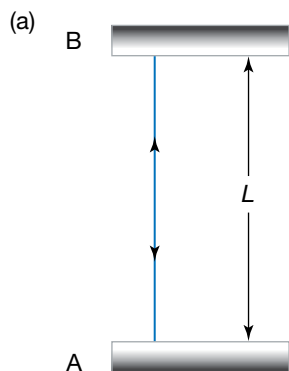

A light clock (a) at rest relative to the observer, and (b) in motion relative to the observer

Imagine an identical clock, with mirrors A' and B', moving past this light clock at speed  $v$ . At what rate does time pass on this moving clock according to

the observer? Label the time interval measured by this clock  $t$  to distinguish it from  $t_0$ . The light leaves  $A'$  and moves towards  $B'$  at speed  $c$ . The speed is still  $c$  even though the clock is moving, as stated by Einstein's second postulate. In the time the light makes this journey, the clock moves a distance  $d = vt_{AB}$ , where  $t_{AB}$  is the time the light takes to travel from  $A'$  to  $B'$ . Diagram (b) depicts this situation and shows that the light in the moving frame of reference has further to travel than the light in the rest frame. Using Pythagoras's theorem, the light has travelled a distance of  $2\sqrt{L^2 + (vt_{AB})^2}$  from  $A'$  to  $B'$  and back to  $A'$ . This is a greater distance than  $2L$ , given  $v \neq 0$  and  $c$  is constant. Therefore, the time the light takes to complete the tick must be greater than for the rest clock.

The speed of the light relative to the observer is:

$$c = \frac{d}{t}$$

$$c = \frac{2\sqrt{L^2 + (vt_{AB})^2}}{2t_{AB}}$$

Transpose the equation to make a formula for  $t$ :

$$2ct_{AB} = 2\sqrt{L^2 + v^2(t_{AB})^2}$$

$$c^2(t_{AB})^2 = L^2 + v^2(t_{AB})^2$$

But  $t_{AB} = \frac{t}{2}$ .

$$\frac{c^2t^2}{4} - \frac{v^2t^2}{4} = L^2$$

$$t^2(c^2 - v^2) = 4L^2$$

$$t = \frac{2L}{\sqrt{c^2 - v^2}}$$

$$= \frac{2L}{c\sqrt{1 - \frac{v^2}{c^2}}}$$

We have already determined that  $t_0 = \frac{2L}{c}$ , so

$$t = \frac{t_0}{\sqrt{1 - \frac{v^2}{c^2}}}$$

The expression  $\frac{1}{\sqrt{1 - \frac{v^2}{c^2}}}$  appears frequently in special relativity. So that

we do not have to write it all the time, it is simply called gamma,  $\gamma$ . It is also known as the Lorentz factor.

We can now write the equation as  $t = t_0\gamma$ .

The equation  $t = t_0\gamma$  is the known as the **time dilation** formula. This formula enables us to determine the time interval between two events in a reference frame moving relative to an observer.

Note that gamma is always greater than 1. As a result,  $t$  will always be greater than  $t_0$ , hence the term 'time dilation'. In a reference frame moving relative to the observer like this, the two events that we are using to mark the time interval, the time between the light being at A, occur at different points in space. The

---

**Time dilation** describes the slowing of time by clocks moving relative to the observer.

**study on**

Unit 3

**Proper time**

AOS 3

Concept summary  
and practice

Topic 5

questions

Concept 6

The **proper time** between two events is the time measured in a frame of reference where the events occur at the same point in space. The proper time of a clock is the time the clock measures in its own reference frame.

time  $t_0$  is the time measured in a frame of reference where the events occur at the same points in space. It is known as the **proper time**. This is not proper in the sense of correct, but in the sense of property. It is the time in the clock's own reference frame, whatever that clock might be.

Examples:

1. A mechanical clock's large hand moves from the 12 to the 3, showing that 15 minutes have passed. Fifteen minutes is the proper time between the two events of the clock showing the hour and the clock showing quarter past the hour. However, if that clock was moving relative to us at great speed, we would notice that the time between these two events was longer than 15 minutes. The time is dilated.
2. A candle burns 2 centimetres in 1 hour. One hour is the proper time between the events of the candle being at a particular length and the candle being 2 centimetres shorter. If the candle was moving relative to the observer, she would notice that it took longer than 1 hour for the candle to burn down 2 centimetres.
3. A man dies at 89 years of age. His life of 89 years is the time between the events of his birth and his death in his reference frame. To an observer moving past at great speed, the man appears to live longer than 89 years. He does not fit any more into his life; everything he does appears to the observer as if it was slowed down.

**Sample problem 3.7**

James observes a clock held by his friend Mabry moving past at  $0.5c$ . He notices the hands change from 12 pm to 12.05 pm, indicating that 5 minutes have passed for the clock. How much time has passed for James?

**Solution:** The proper time  $t_0$  is the time interval between the two events of the clock showing 12 pm and the clock showing 12.05 pm, which is 5 minutes.

$$\gamma = \frac{1}{\sqrt{1 - \frac{v^2}{c^2}}} = 1.155 \text{ when } v = 0.5c.$$

So  $t = t_0\gamma = 5 \times 1.155 = 5.775$  minutes.

James notices that the moving clock takes 5.775 minutes (or 5 minutes 46.5 seconds) for its hands to move from 12 pm to 12.05 pm.

**Revision question 3.7**

In another measurement, James looks at his own clock and waits the 5 minutes it takes for the clock to change from 1 pm to 1.05 pm. He then looks at Mabry's clock as she moves past at  $0.5c$ . How much time has passed on her clock?

Unlike in Newtonian physics, time intervals in special relativity are not invariant. Rather, they are relative to the observer.

**Sample problem 3.8**

Mabry is travelling past James at  $0.5c$ . She looks at James and sees his clock ticking. How long does she observe it to take for his clock to indicate the passing of 5 minutes?

**Solution:** In this case it is James's clock that is showing the proper time. Mabry notices that 5.775 minutes pass when James's clock shows 5 minutes passing. These situations are symmetrical. Mabry sees James as moving at  $0.5c$ , and James sees Mabry moving at  $0.5c$ , so her measurement of time passing is the same as his.

### Revision question 3.8

Aixi listens to a 3-minute song on her phone. As soon as she starts the song she sees her friend Xiaobo start wrestling with his brother on a spaceship moving by at  $0.8c$ . When the song finishes, she sees Xiaobo stop wrestling. How long were the two boys wrestling for?

### Sample problem 3.9

A car passes Eleanor at  $20 \text{ m s}^{-1}$ . She compares the rate that a clock in the car ticks with the rate the clock in her hand ticks.

**Solution:** 
$$\gamma = \frac{1}{\sqrt{1 - \frac{v^2}{c^2}}} = 1.000\,000\,000\,000\,0022 \text{ when } v = 20 \text{ m s}^{-1}.$$

The difference between the rates of time in the two perspectives is so small that it is difficult to calculate, much less to notice it.

### Revision question 3.9

Jonathan observes a clock on a passing spaceship to be ticking at half the rate of his identical clock. What is the relative speed of Jonathan and the passing spaceship?

Newton's assumption that all clocks tick at the same rate, regardless of their inertial reference frame, was very reasonable. Learning the very good approximation of Newton's laws is well justified. They are simpler than Einstein's laws, and they work for all but the highest speeds. A good theory in science has to fit the facts, and Newton's physics fit the data very successfully for 200 years. It was a great theory, but Einstein's is even better.

If Newton knew then what we know now, he would realise that his theories were in trouble. At speeds humans normally experience, time dilation is negligible, but the dilation increases dramatically as objects approach the speed of light. If you passed a planet at  $2.9 \times 10^8 \text{ m s}^{-1}$ , you would measure the aliens' usual school lessons of 50 minutes as taking 195 minutes. An increase in speed to  $2.99 \times 10^8 \text{ m s}^{-1}$  would dilate the period to 613 minutes. If you could achieve the speed of light, the period would last forever — time would stop.

Photons do not age, as they do not experience time passing!

## Time dilation and modern technology

Time dilation has great practical significance. A global positioning system (GPS) is able to tell you where you are, anywhere on Earth, in terms of longitude, latitude and altitude, to within a few metres. To achieve this precision, the system has to compensate for relativistic effects, including time dilation, because it depends on satellites moving in orbit. Einstein's general relativity also shows that the difference in gravity acting on a satellite in orbit affects the time significantly. Nanosecond accuracy is required for a GPS, but if Newtonian physics was used the timing would be out by more than 30 microseconds. GPSs are widely used in satellite navigation, and ships, planes, car drivers and bushwalkers can find their bearings far more accurately than they ever could using a compass.

## Length contraction

Once we accept that simultaneity of events and the rate that time passes are relative, we have to accept that length must be relative as well. The length of an object is simply the distance between the two ends of the object. To find



With a GPS device you can know your position to within a few metres.



that distance, the position of both ends must be noted at the same time. If they were measured at different times, a moving object would have changed position, so the distance between the end that was measured second and the end that was measured first would have changed. The fact that any two inertial reference frames do not agree on which events are simultaneous is going to cause the measurement of length to be different in different reference frames. The speed of light is invariant and time is relative, so we have even more reason to doubt that lengths will be the same for all observers.

A clever thought experiment of Einstein's enables us to determine the effect the speed of an observer has on a length to be measured. It is essentially the same as the thought experiment used to derive the time dilation equation, but with the light clock tipped on its side so that its length is aligned with the direction of its motion.

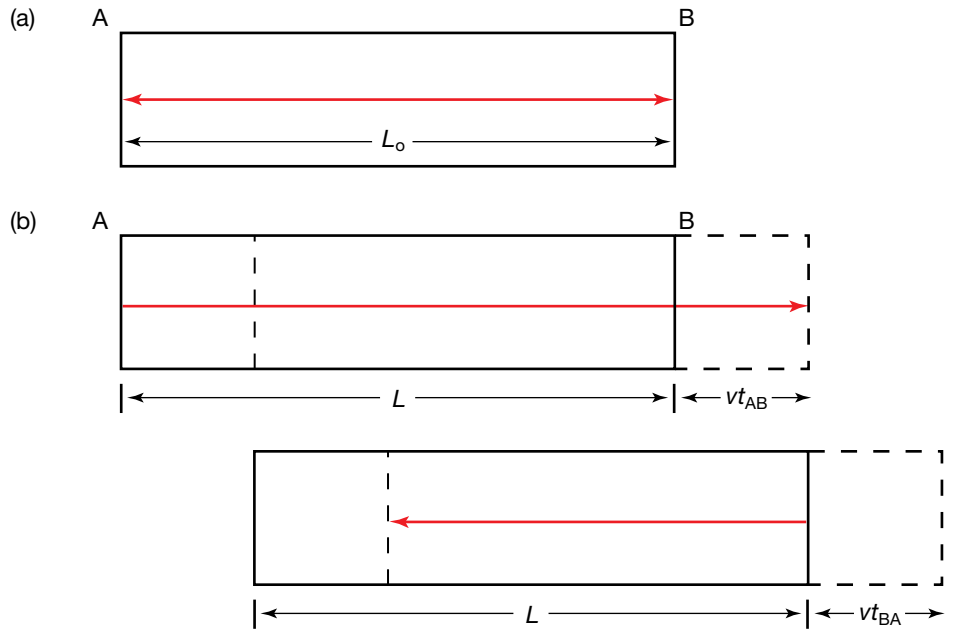

Light journeys in (a) a clock at rest and (b) a clock moving to the right at speed  $v$

From the reference frame of the clock, again  $t_0 = \frac{2L}{c}$ . What about the reference frame of an observer with a speed of  $v$  relative to the clock? We can measure the distance between the ends of the clock using the time for light to travel from one end to the other and back.

From A to B:

$$L + vt_{AB} = ct_{AB}$$

where

$L$  = the length of the clock as observed by the moving observer

$vt_{AB}$  = the distance the clock has moved in the time the light passes from A to B

$ct_{AB}$  = the distance the light has travelled passing from A to B.

Transposing the equation to make  $t_{AB}$  the subject:

$$t_{AB} = \frac{L}{c-v}$$

From B to A:

$$L - vt_{BA} = ct_{BA}$$

where

$vt_{BA}$  = the distance the clock has moved in the time the light passes from B back to A

$ct_{BA}$  = the distance the light has travelled passing from B back to A.

Transposing the equation to make  $t_{BA}$  the subject:

$$t_{AB} = \frac{L}{c+v}.$$

As A moves to meet the light, the time  $t_{BA}$  is less than  $t_{AB}$ . The total time is:

$$\begin{aligned} t &= t_{AB} + t_{BA} \\ &= \frac{L}{c-v} + \frac{L}{c+v} \\ &= \frac{2Lc}{c^2 - v^2} \\ &= \frac{2L}{c \left( 1 - \frac{v^2}{c^2} \right)}. \end{aligned}$$

According to the time dilation formula:

$$t = \frac{t_0}{\sqrt{1 - \frac{v^2}{c^2}}}.$$

Substituting this for our time in the moving clock gives:

$$\begin{aligned} \frac{t_0}{\sqrt{1 - \frac{v^2}{c^2}}} &= \frac{2L}{c \left( 1 - \frac{v^2}{c^2} \right)} \\ t_0 &= \frac{2L}{c \sqrt{1 - \frac{v^2}{c^2}}}. \end{aligned}$$

Substituting  $t_0 = \frac{2L_0}{c}$  gives:

$$\begin{aligned} \frac{2L_0}{c} &= \frac{2L}{c \sqrt{1 - \frac{v^2}{c^2}}} \\ \Rightarrow L_0 &= \frac{L}{\sqrt{1 - \frac{v^2}{c^2}}} \text{ or } L = \frac{L_0}{\gamma}. \end{aligned}$$

The formula  $L = L_0 \sqrt{1 - \frac{v^2}{c^2}}$  is known as the Lorentz contraction formula after one of the early pioneers of relativity theory, Hendrik Antoon Lorentz (1853–1928). The Lorentz contraction is the shortening of an object in its direction of motion when measured from a reference frame in motion relative to the object.

The **proper length** of an object,  $L_0$ , is the length measured in the rest frame of the object.  $L$  is the length as measured from an inertial reference frame

---

The **proper length** of an object is the length measured in the rest frame of the object.

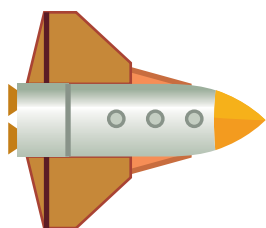

at rest

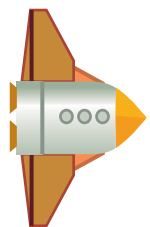

$v = 0.86c$

A spaceship travelling at high speed has its length contracted. The contraction is only in the direction of motion of the spaceship.

### study on

Unit 3

**Proper length**

AOS 3

Concept summary and practice

Topic 5

questions

Concept 7

travelling at a velocity  $v$  relative to the object. This change in length applies only to the length along the direction of motion. The other dimensions are not affected by this contraction.

### AS A MATTER OF FACT

George Fitzgerald and Hendrik Lorentz independently proposed an explanation for the result of the Michelson–Morley experiment (in 1889 and 1892 respectively). If the length of the apparatus contracted in the direction of Earth’s movement, then the light would take the same time to travel the two paths. This explanation assumed that the aether existed and that light would travel at constant speed through it; therefore, light would travel at different speeds relative to Earth as Earth moved through the aether. This explanation was not completely satisfying as there was no known force that would cause the contraction, and the aether had never been directly detected. The contraction would be measured by those in the reference frame at rest with respect to the aether.

In special relativity, any observer in motion relative to an object measures a contraction. As the contraction is simply a feature of observation from different reference frames, no force is required to cause the contraction. Nothing actually happens to the object in its reference frame.

The Lorentz contraction is negligible at velocities we commonly experience. Even at a relative speed of 10% of the speed of light, the contraction is less than 1%. As speed increases beyond  $0.1c$ , however, the contraction increases until at relative speed  $c$ , the length becomes zero.

### Sample problem 3.10

Observers on Earth observe the length of a spacecraft travelling at  $0.5c$  to have contracted. By what percentage of its proper length is the spacecraft contracted according to the observers?

**Solution:**

$$L = \frac{L_0}{\gamma}$$

$$\frac{L}{L_0} = \frac{1}{\gamma}$$

$$= \frac{1}{1.155}$$

$$= 0.866$$

The spacecraft appears to be only 0.866 or 86.6% of its proper length. This is a contraction of 13.4%.

### Revision question 3.10

Rebecca and Madeline take measurements of the journey from Melbourne to Sydney. Rebecca stays in Melbourne and stretches a hypothetical tape measure between the two cities. Madeline travels towards Sydney at great speed and measures the distance with her own measuring tape that is in her own reference frame.

- How would the two measurements compare, assuming that perfect precision could be achieved?
- Which measurement could be considered to be the proper length of the journey? Explain.

## AS A MATTER OF FACT

### The twins paradox

A paradox is a seemingly absurd or contradictory statement. Relativity provides a few paradoxes that are useful in teaching the implications of relativity. The ‘twins paradox’ is probably the best known. Despite its name, the twins paradox is explained fully by the logic of relativity.

Imagine a spacecraft that starts its journey from Earth. After 3 years in Earth time it will turn around and come back, so that those on Earth measure the total time between the events of the launch and the return to take 6 years. The astronaut, Peter, leaves his twin brother, Mark, on Earth. During this time, Peter and Mark agree that Earth has not moved from its path through space, it is Peter in his spaceship who has gone on a journey and has experienced the effects of acceleration that Mark has not. Mark measures the length of Peter’s journey from Earth. His measurement is longer than Peter’s due to length contraction, but the speed of Peter is measured relative to Earth. They disagree on distance travelled but not speed, so they must disagree on time taken. This is not just an intellectual dispute — the difference in time will show in their ageing, with Peter actually being younger than Mark on his return to Earth.

We all go on a journey into the future; we cannot stop time. Relativity shows us that the rate that time progresses depends on the movements we make through space on the journey. Coasting along in an inertial reference frame is the longest path to take. Zipping through different reference frames then returning home enables objects to reach the future in a shorter time: they take a longer journey through space but a shorter journey through time.

The twins scenario may sound incredible, but it has been verified experimentally. The most accurate clocks ever built are atomic clocks. They make use of the oscillation of the atoms of particular elements. The period of this oscillation is unaffected even by quite extreme temperatures and accelerations, making the clocks without rival in terms of accuracy. These clocks have been flown around the world on airliners, recording less elapsed time than for similar clocks that remained on the ground. The effect is tiny, but the clocks have more than adequate precision to detect the difference. The difference measured is consistent with the time difference predicted by special relativity.

## AS A MATTER OF FACT

### The parking spot paradox

Can a long car enter a parking spot that is too short for it by making use of length contraction? The answer is yes and no. To explain, consider another famous paradox of relativity.

Charlotte’s car is 8 m long and she proudly drives it at a speed of  $0.8c$ . She observes her friend Alexandra, who is stationary on the roadside, and asks her to measure the length of her car. (For the sake of argument, we will ignore the issues of where a car could go at such a huge speed, and how Alexandra communicates with Charlotte and measures the car.)

Alexandra says that Charlotte must be dreaming if she thinks her car is 8 m long, because she measures it to be only 4.8 m long. She believes her measurements to be accurate.

To prove her point, Alexandra marks out a parking spot 4.8 m long. She says that if Charlotte can park her car in the spot, then the car is not as long as she thinks. Charlotte argues that her car will not fit in a 4.8 m parking spot, but she agrees to the test.

From Charlotte's frame of reference, the parking spot would be merely 2.9 m long. This is because it has a length contraction due to the car's relative motion of  $0.8c$ . Alexandra's measuring equipment detects that the front of the car reaches the front of the parking spot at the same instant as the back of the car fits in the back. However, much to Alexandra's amazement, the stopped car is 8 m long. Charlotte and Alexandra now agree that the stopped car does not fit the 4.8 m parking spot, and that it has a length of 8 m. This may at first seem impossible, which is why it is sometimes called a paradox. Once we consider that Charlotte and Alexandra do not agree on which events are simultaneous, the paradox is resolved. Alexandra measured the front and the back of the car to be within the parking spot at the same time but did not check that the front and back had stopped.

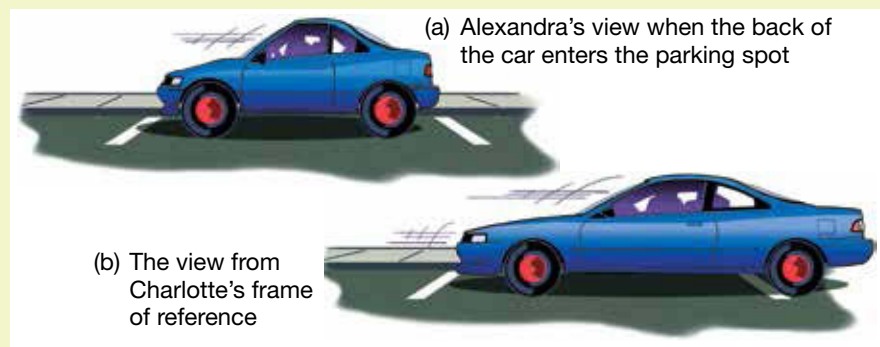

The parking spot paradox

## A note on seeing relativistic effects

In this chapter, we use the term observer frequently. Much of the imagery used in teaching relativity is in principle true but in practicality fantasy. Seeing anything in detail that is moving at close to the speed of light is not feasible. However, measuring distances and times associated with these objects is reasonable. Images formed of objects moving at speeds approaching  $c$  will be the result of time dilation, length contraction and other effects including the relativistic Doppler effect and the aberration of light.

Imagine speeding through space in a very fast spacecraft. When you planned your trip on Earth, you forgot to take relativity into account. Everything on board would appear normal throughout the trip, but when you looked out the front window, the effects of relative speed would be obvious. Some examples of what you would see include: aberration of light causing the stars to group closer together, so that your forward field of vision would be increased; the Doppler effect causing the colours of stars to change; and the voyage taking much less time than you expected.

## The journey of muons

Bruno Rossi and David Hall performed a beautiful experiment in 1941, the results of which are consistent with both time dilation and length contraction. Earth is constantly bombarded by energetic radiation from space, known as cosmic radiation. These rays collide with the upper atmosphere, producing

particles known as muons. Muons are known to have a very short half-life, measured in the laboratory to be 1.56 microseconds. Given the speed at which they travel and the distance they travel through the atmosphere, the vast majority of muons would decay before they hit the ground.

The Rossi–Hall experiment involved measuring the number of muons colliding with a detector on top of a tall mountain and comparing this number with how many muons were detected at a lower point. They found that far more muons survived the journey through the atmosphere than would be predicted without time dilation. The muons were travelling so fast relative to Earth that the muons decayed at a much slower rate for observers on Earth than they would at rest in the laboratory. The journey between the detectors took about 6.5 microseconds according to Earth-based clocks, but the muons decayed as though only 0.7 microseconds had passed. Due to length contraction, the muons did not see the tall mountain but, rather, a small hill. Rossi and Hall were not surprised that the muons survived the journey at all.

Muons are a measurable example of special relativistic effects.

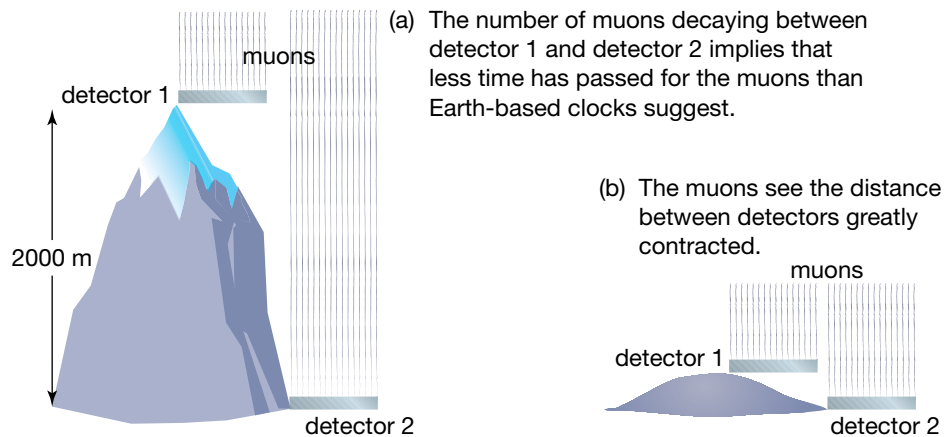

### Sample problem 3.11

Use the description of the Rossi–Hall experiment above to answer the following questions.

- What is the proper time for the half-life of muons?
- What is the value of gamma as determined from the journey times from the different reference frames?
- How fast were the muons travelling through the atmosphere according to the value for gamma?
- Calculate the half-life of the muons from the reference frame of the Earth.

**Solution:** (a) The proper time for the half-life is in the reference frame of the muon and is 1.56 microseconds.

(b)  $t = t_0\gamma$

$$\gamma = \frac{t}{t_0} = \frac{6.5}{0.7} = 9.29$$

(c)  $\gamma = \frac{1}{\sqrt{1 - \frac{v^2}{c^2}}}$

$$v = c\sqrt{1 - \frac{1}{\gamma^2}} = c\sqrt{1 - \frac{1}{9.29^2}} = 0.994c$$

(d)  $t = t_0\gamma$

$$t = 1.56 \times 10^{-6} \times 9.29 = 14 \mu\text{s}$$

### Revision question 3.11

Use the description of the Rossi–Hall experiment above to answer the following questions.

- Use the travel time from the Earth reference frame and the speed of the muons to calculate the height of the mountain.
- Use the travel time of the muons to determine how high the mountain appeared to the muons.

## The most famous equation: $E = mc^2$

The result of special relativity that people are most familiar with is the equation  $E = mc^2$ . In fact, it is probably the most well known equation of all. This formula expresses an equivalence of mass and energy. If we do work,  $\Delta E$ , on an object, that is we increase its energy, its mass will increase. Usually, however, we do not notice this increase in mass because of the factor  $c^2 = 9 \times 10^{16} \text{ m}^2 \text{ s}^{-2}$ . According to  $\Delta E = \Delta mc^2$ , it would take  $9 \times 10^{16} \text{ J}$  of energy to increase the mass by 1 kg. This is similar to the amount of electrical energy produced in Victoria every year. Conversely, if we could convert every gram of a 1 kg mass into electricity, we would supply Victoria's electricity needs for a year. Nuclear fission reactors produce electricity from the small loss of mass that occurs when large nuclei such those of uranium-235 undergo fission. The Sun and other stars generate their energy by losing mass to nuclear fusion.

A simplified derivation of this equation can help us gain a sense of the physics involved. Consider a box suspended in space, with no external forces acting on it, as shown in the figure below. Maxwell found that electromagnetic radiation carries momentum  $p = \frac{E}{c}$  where  $E$  is the energy transmitted and  $c$  is the speed of light. In the context of photons, each photon carries a momentum  $p = \frac{E}{c}$ . As a result, light exerts pressure on surfaces. This effect can nudge satellites out of orbit over time.

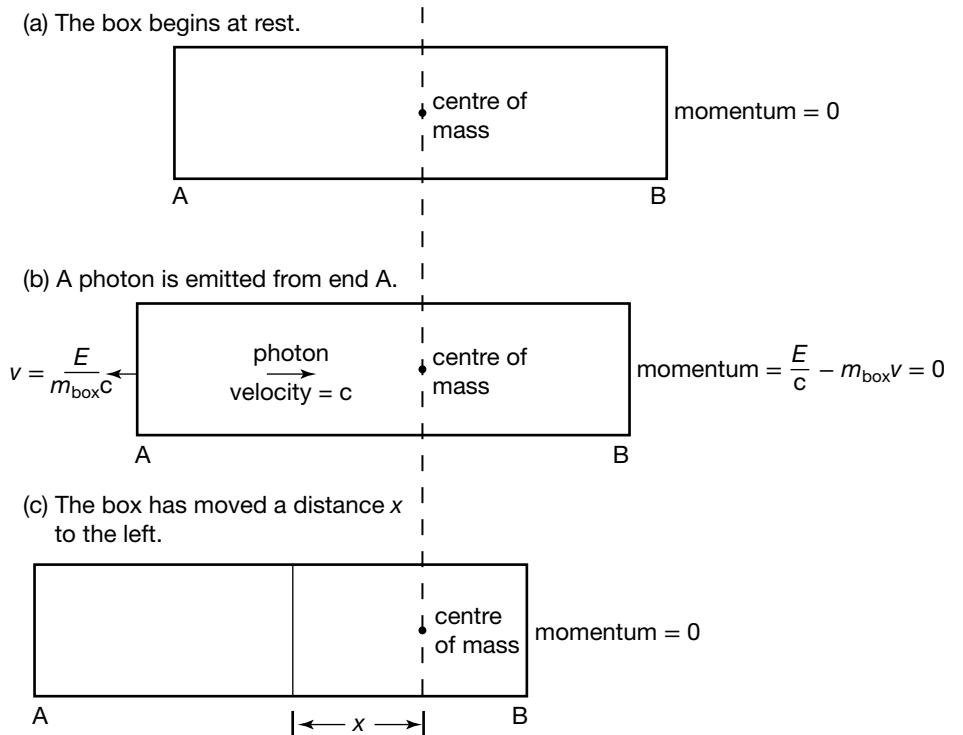

Einstein's box suspended in space

In (a), the box begins at rest. The total momentum is zero and its centre of mass is in the centre.

In (b), a photon of energy  $E$  is emitted from end A, carrying momentum with it. To conserve momentum, the box moves in the direction opposite to the movement of the photon.

$$p_{\text{photon}} + p_{\text{box}} = 0$$

$$\Rightarrow \frac{E}{c} - m_{\text{box}}v = 0$$

where

$m_{\text{box}}$  = the mass of the box

$v$  = the velocity of the box.

Rearranging gives us the velocity of the box in the leftward direction,  $v = \frac{E}{m_{\text{box}}c}$ , a very small number!

In (c), after time  $\Delta t$ , the light pulse strikes the other end of the box and is absorbed. The momentum of the photon is also absorbed into the box, bringing the box to a stop. In this process, the box has moved a distance  $x$  where:

$$x = v\Delta t.$$

Substituting  $v = \frac{E}{m_{\text{box}}c}$  from (b) gives

$$x = \frac{E\Delta t}{m_{\text{box}}c}.$$

As  $v$  is very small (almost non-existent), we can assume that the photon travels the full length of the box and put  $\Delta t = \frac{L}{c}$ . Substituting this into  $x = \frac{E\Delta t}{m_{\text{box}}c}$  gives:

$$x = \frac{EL}{m_{\text{box}}c^2}.$$

$$\text{or } E = \frac{xm_{\text{box}}c^2}{L}.$$

There are no external forces acting on the box, so the position of the centre of mass must remain unchanged (see the dotted line in the diagram). The box moved to the left as a result of the transfer of the energy of the photon to the right. Therefore, the transfer of the photon must be the equivalent of a transfer of mass. If we can show that  $\frac{xm_{\text{box}}}{L}$  is the same as the mass equivalent of the transferred energy, we have our answer. To show this, we will pay attention to the shift in the box relative to the centre of mass of the system.

The centre of mass is the point where the box would balance if suspended. This can be determined by balancing moments — the mass times the distance from a reference point. We choose the centre of the box as the reference point to ensure that the distance  $x$  is in our calculations. The moment for the box is  $m_{\text{box}}x$  anticlockwise, because the mass of the box can be considered to be acting through a point at distance  $x$  to the left of the reference point. The photon's equivalent mass is acting at distance  $\frac{L}{2}$  to the right of the reference point, so its moment is  $m\frac{L}{2}$  clockwise. However, this moment was acting on the other end of the box before the photon was emitted, so we can consider its absence from that end of the box as an equal moment in the same direction. We then have:

$$m_{\text{box}}x = m\frac{L}{2} + m\frac{L}{2}$$

$$\text{or } m = \frac{m_{\text{box}}x}{L} \text{ as required.}$$



Substitute this into  $E = \frac{xm_{\text{box}}c^2}{L}$  and we have  $E = mc^2$ .

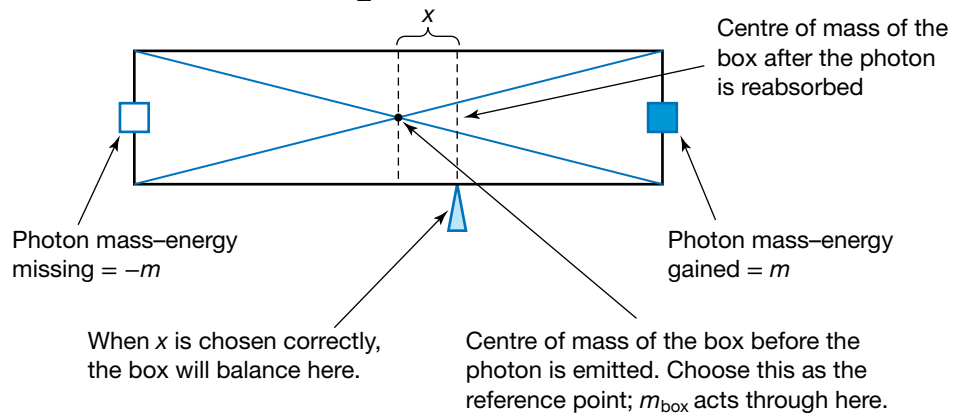

### Balancing Einstein's box

In other words, when the photon carried energy to the other end of the box, it had the same effect as if it had carried mass. In fact, Einstein concluded that energy and mass are equivalent. If we say that some energy has passed from one end of the box to the other, we are equally justified in saying that mass has passed as well. Note the distinction: the photon carries an amount of energy that is equivalent to an amount of mass, but the photon itself does not have mass.

One implication of this is that the measurement of mass depends on the relative motion of the observer. The kinetic energy of a body depends on the inertial reference frame from which it is measured. The faster the motion, the greater the kinetic energy. So kinetic energy is relative, and so is mass! Energy is equivalent to mass, so the mass of an object increases as its velocity relative to an observer increases.

The mass of an object that is in the same inertial frame as the observer is called its **rest mass** ( $m_0$ ). When measured from other reference frames, the mass is given by  $m = m_0\gamma$ . The derivation of this is complex, so it will not be addressed here.

The mass of an object measured at rest is called its **rest mass**.

### Sample problem 3.12

Use  $m = m_0\gamma$  to show that it is not possible for a mass to exceed the speed of light.

**Solution:** If  $v = c$ ,  $\gamma$  becomes infinitely large. As  $m = m_0\gamma$ , an object travelling at  $c$  would have infinite mass. Speeds larger than  $c$  would produce a negative under the square root sign, so these speeds are not possible.

### Revision question 3.12

The Earth ( $m = 6 \times 10^{24}$  kg) moves around the Sun at close to  $30\,000$  m s<sup>-1</sup>. From the Sun's frame of reference, how much additional mass does the Earth have?

### Sample problem 3.13

Calculate the mass increase of a proton that is accelerated from rest using 11 GeV of energy, an energy that can be achieved in particle accelerators.

**Solution:**

$$\begin{aligned}\Delta E &= 11 \text{ GeV} \\ &= 11 \times 10^9 \times 1.6 \times 10^{-19} \text{ J} \\ &= 1.76 \times 10^{-9} \text{ J}\end{aligned}$$

$$\begin{aligned}\Delta m &= \frac{\Delta E}{c^2} \\ &= \frac{1.76 \times 10^{-9} \text{ J}}{(3 \times 10^8 \text{ m s}^{-1})^2} \\ &= 1.96 \times 10^{-26} \text{ kg}\end{aligned}$$

Note that the rest mass of a proton is  $1.67 \times 10^{-27} \text{ kg}$ , so the accelerated proton behaves as though its mass is nearly 13 times its rest mass.

### Sample problem 3.14

In Newtonian physics, if we gave a proton 11 GeV of kinetic energy, what would be its speed?

**Solution:**

$$\begin{aligned}E &= \frac{1}{2}mv^2 \\ v &= \sqrt{\frac{2E}{m}} \\ &= \sqrt{\frac{2 \times 11 \times 10^9 \times 1.6 \times 10^{-19}}{1.67 \times 10^{-27}}} \\ &= 1.45 \times 10^9 \text{ m s}^{-1}\end{aligned}$$

This speed is not possible as the maximum speed attainable is  $3 \times 10^8 \text{ m s}^{-1}$ .

The solution to sample problem 3.14 is well in excess of the speed of light, and is an example of the limitations of Newtonian physics. In relativity, when more energy is given to a particle that is approaching the speed of light, the energy causes a large change in mass and a small change in speed. By doing work on the particle, the particle gains inertia, so the increase in energy has an ever-decreasing effect on the speed. The speed cannot increase beyond the speed of light, no matter how much energy the particle is given.

In particle accelerators, where particles are accelerated to near the speed of light, every tiny increase in the speed of the particles requires huge amounts of energy. Physicists working in this field rely on ever-higher energies to make new discoveries. This costs huge amounts of money. Nonetheless, a number of accelerators have been built that are used by scientists from around the world. This area of research is often called high-energy physics. At these high energies, Newtonian mechanics is hopelessly inadequate and Einstein's relativity is essential.

Particle accelerators such as the Australian Synchrotron in Melbourne accelerate subatomic particles to near-light speeds, where special relativity is essential for understanding the behaviour of the particles. Electrons in the Australian Synchrotron have kinetic energies up to 3 GeV.



**study on**

Unit 3

**Mass-energy**

AOS 3

Concept summary  
and practice  
questions

Topic 5

Concept 8

As mass and energy are equivalent, they can be described as a single concept, **mass-energy**. The mass-energy of an object is given by  $E = mc^2$ .

## Kinetic energy in special relativity

This equivalence of mass and energy has resulted in the term mass-energy. The **mass-energy** of any object is given by  $E = mc^2$ . With mass-energy, a moving particle has kinetic energy and rest energy. Rest energy is the energy equivalent of the mass at rest given by  $E = mc^2$ .

So we have:

$$E = E_k + E_{\text{rest}}$$

Substituting for  $E$  and  $E_{\text{rest}}$ , we have

$$mc^2 = E_k + m_0c^2.$$

Rearranging and substituting,

$$\begin{aligned} E_k &= mc^2 - m_0c^2 \\ &= m_0\gamma c^2 - m_0c^2 \\ &= (\gamma - 1)m_0c^2. \end{aligned}$$

This is the expression we must use for kinetic energy when dealing with high speeds, particularly those exceeding 10% of the speed of light.

### Sample problem 3.15

Calculate the kinetic energy of a 10 000 kg spacecraft travelling at  $0.5c$  and compare this with the kinetic energy that you would calculate using classical physics (that is,  $E_k = \frac{1}{2}mv^2$ ).

**Solution:** Using special relativity,

$$\begin{aligned} E_k &= (\gamma - 1)m_0c^2 \\ &= \left( \frac{1}{\sqrt{1 - 0.5^2}} - 1 \right) \times 10\,000 \times (3 \times 10^8)^2 \\ &= 1.39 \times 10^{20} \text{ J.} \end{aligned}$$

Using classical physics,

$$\begin{aligned} E_k &= \frac{1}{2}mv^2 \\ &= \frac{1}{2} \times 10\,000 \times (0.5 \times 3 \times 10^8)^2 \\ &= 1.13 \times 10^{20} \text{ J.} \end{aligned}$$

The kinetic energy is  $\frac{1.39}{1.13} = 1.23$  times the value predicted by classical physics.

### Revision question 3.13

A particle accelerator is designed to give electrons 10 GeV of kinetic energy. How fast can it make electrons travel?

## Mass conversion in the Sun

In Unit 1 we considered the generation of energy in the core of the Sun and other stars. One of the consequences of Einstein's great contribution to our understanding of relativity is that we understand now a great deal about how energy is generated by the Sun. At the centre of it all is the equation  $E = mc^2$ . The Sun continuously converts mass-energy stored as mass into radiant light and heat. Each second the Sun radiates enough energy to meet current human requirements for billions of years. It takes the energy generated in the core

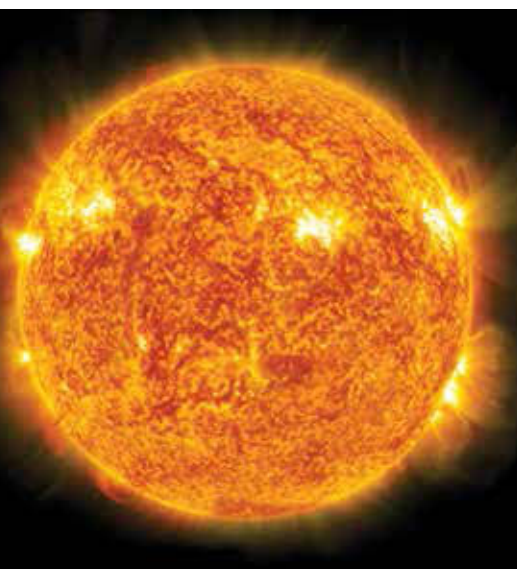

The Sun's energy comes from nuclear fusion converting mass into energy.

about 100 000 years to reach the surface. Even if the fusion in the Sun stopped today, it would take tens of thousands of years before there was a significant impact on Earth.

The Sun is a ball made up mostly of hydrogen plasma and some ionised atoms of lighter elements. The temperatures in the Sun ensure that virtually all of the atoms are ionised. The composition of the Sun is shown in this table.

**TABLE 3.1** The composition of the Sun

Element	Percentage of total number of nuclei in the Sun	Percentage of total mass of the Sun
Hydrogen	91.2	71.0
Helium	8.7	27.1
Oxygen	0.078	0.97
Carbon	0.043	0.40
Nitrogen	0.0088	0.096
Silicon	0.0045	0.099
Magnesium	0.0038	0.076
Neon	0.0035	0.058
Iron	0.030	0.014
Sulfur	0.015	0.040

At this stage of the Sun's life cycle, it is ionised hydrogen atoms (i.e. protons) that provide the energy. The abundance of protons and the temperatures and pressures in the core of the Sun are sufficient to fuse hydrogen, but not heavier nuclei. The energies of the protons in the Sun have a wide distribution from cool, slow protons to extremely hot, fast protons. It is only the most energetic protons, about one in a hundred billion, that have the energy required to overcome the electrostatic repulsion and undergo fusion. The Sun is in a very stable phase of fusing hydrogen that is expected to last for billions of years to come.

Fusion in the Sun occurs mainly through the following process:

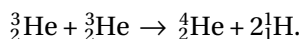
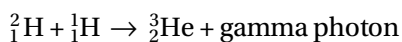
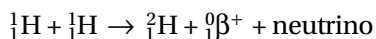

which can be summed up by the following equation:



The energy is released mainly through the gamma photons and the annihilation of the positrons when they meet free electrons in the Sun. The net result is an enormous release of energy and a corresponding loss of mass. The mass loss has been measured to be 4.4 Tg ( $4.4 \times 10^9$  kg) per second. As the mass of the Sun is around  $2.0 \times 10^{30}$  kg, even at this incredible rate, there is plenty of hydrogen to sustain it for about twice its age of four and a half billion years.

### Sample problem 3.16

A nucleus of hydrogen-2 made of one proton and one neutron has a smaller mass than the total of an individual proton and an individual neutron. Account for this mass difference.

**Solution:** The mass of the nucleus is different to the mass of the individual particles, but when the binding energy of the hydrogen-2 nucleus is included, we find that the mass-energy of both is the same. The separate particles have their mass and zero potential energy. The particles bound in the nucleus have a reduced mass and the binding energy of the nucleus. (The binding energy is the energy required to separate the particles. It is released as a combination of increased kinetic energy of the particles and gamma rays.)

### Sample problem 3.17

What is the power output of the Sun?

**Solution:**

$$\begin{aligned} E &= mc^2 \\ &= 4.4 \times 10^9 \times (3.0 \times 10^8)^2 \text{ J} \\ &= 4.0 \times 10^{26} \text{ J} \\ P &= \frac{E}{t} \\ &= 4.0 \times 10^{26} \text{ W} \end{aligned}$$

The mass loss of  $4.4 \times 10^9 \text{ kg s}^{-1}$  equates to a power output of  $4.0 \times 10^{26} \text{ W}$ .



# Chapter review

## Summary

- There is no frame of reference that is at absolute rest. Velocity is always relative to a chosen reference frame.
- Classical physics is the physics established by Galileo, Newton and other scientists before the twentieth century. It does not include twentieth-century developments in physics, such as special relativity and quantum mechanics.
- In classical physics, velocity is relative but time, distance and mass measurements are invariant — they are the same for all observers. Classical physics provides a good approximation at low velocities, but it does not provide accurate values as relative speeds approach the speed of light.
- In special relativity, velocities of masses are still relative but the speed of light is invariant. As a result, it is recognised that the measurement of time intervals, lengths and masses is relative to the reference frame of the observer.
- Einstein's two postulates of special relativity are:
  - the laws of physics are the same in all inertial (non-accelerated) frames of reference
  - the speed of light has a constant value for all observers regardless of their motion or the motion of the source.
- Proper time is the time interval between two events in a reference frame where the two events occur at the same point in space, that is, the reference frame in which the clock is stationary.
- Proper length is the length that is measured in the frame of reference in which objects are at rest.
- In reference frames in motion relative to the observer, time is dilated according to  $t = t_0\gamma$ , where
 
$$\gamma = \frac{1}{\sqrt{1 - \frac{v^2}{c^2}}}$$
- In reference frames in motion relative to the observer, length is contracted along the line of motion according to  $L = \frac{L_0}{\gamma}$ .
- In reference frames in motion relative to the observer, mass increases according to  $m = m_0\gamma$ .
- An example of where the effects of special relativity can be observed is muons formed in the upper atmosphere. They travel to Earth at nearly the speed of light, so that even though most would decay in the time it takes them to reach the surface according to

classical physics, many survive the journey as they see the distance contracted. From the perspective of the Earth, the time is dilated so that the muons have time to reach the surface.

- Kinetic energy is given by the formula  $E_k = (\gamma - 1)m_0c^2$ .
- $E = mc^2$  expresses the equivalence of mass and energy.
- Fusion is the source of the Sun's energy. The Sun is constantly losing mass as it radiates energy in accordance with mass-energy equivalence.

## Questions

### The principle of relativity

1. According to Maxwell, who would see light travelling the fastest?
  - A. Someone moving towards a light source that is stationary in the aether
  - B. Someone who is stationary in the aether with the light source moving away
  - C. Someone who is stationary in the aether with the light source moving towards her
  - D. Someone who is moving away from a light source that is stationary in the aether
2. What is a frame of reference?
3. What do physicists mean when they say that velocity is relative?
4. What is the difference between an inertial and a non-inertial reference frame?
5. How can you determine whether your car is accelerating or moving with constant velocity?
6. Two cars drive in opposite directions along a suburban street at  $50 \text{ km h}^{-1}$ . What is the velocity of one car relative to the other?
7. Explain, using the concept of velocity, why head-on collisions are particularly dangerous. Use an example.
8. Earth varies from motion in a straight line by less than  $1^\circ$  each day due to its motion around the Sun.
  - (a) Explain, with the help of the principle of relativity, why we do not feel Earth moving, even though it is travelling around the Sun at great speed.
  - (b) What are the other motions Earth undergoes that we cannot feel?
  - (c) Earth is not an inertial reference frame. Explain why we often refer to it as though it is.
9. A car accelerates from 0 to  $100 \text{ km h}^{-1}$  in 10 s.
  - (a) What is its acceleration relative to the road?
  - (b) What is its acceleration relative to a car travelling at  $100 \text{ km h}^{-1}$  in the opposite direction?
  - (c) Would you describe the acceleration as absolute, relative, invariant or arbitrary?

10. (a) If Earth is moving at  $100 \text{ km s}^{-1}$  relative to the supposed aether, what speed would Michelson have measured for light emitted in the same direction that Earth is travelling?  
 (b) What speed would Michelson have expected given the aether theory? (Take the speed of light to be  $2.9979 \times 10^8 \text{ m s}^{-1}$ .)
11. (a) What are Einstein's two postulates of special relativity?  
 (b) What is in these postulates that was not present in previous physics?
12. What place did the luminiferous aether take in Einstein's theory?
13. (a) Why did Newton's laws seem correct for so long?  
 (b) Why do we often still use Newton's laws today?
14. Why is Einstein's second postulate surprising? Give an example to show why Newtonian physicists would think it wrong.
15. A star emits light at speed  $c$ . A second star is hurtling towards it with speed  $0.3c$ . What is the speed of the light when it hits the second star relative to this second star?
16. Explain how Einstein's second postulate makes sense of the results of the Michelson–Morley experiment.

### Special relativistic effects on length and distance

17. What is time dilation? In your explanation, give an example of where time dilation would occur.
18. If a box was moving away from you at nearly light speed, which dimensions of the box would undergo length contraction from your perspective: width, height or depth?
19. Which clock runs slow: yours or one in motion relative to you?
20. You observe that an astronaut moving very quickly away from you ages at a slower rate than you. The astronaut views you as ageing faster than she ages. True or false? Explain.
21. The twins paradox shows that less time passes for the travelling twin. Does this also mean that the twin will return shortened due to length contraction? Explain.
22. Draw diagrams of a light clock in motion and at rest to explain why time dilation occurs for moving clocks.
23. Explain why time dilation must occur for all clocks, not just the light clock.
24. Explain the difference between  $t_0$  and  $t$  in the time dilation formula.
25. Two spacecraft pass each other with a relative speed of  $0.3c$ .  
 (a) Calculate  $\gamma$ .  
 (b) A drummer pounds a drum at 100 beats per minute on one of the spacecraft. How many beats per minute would those on the other spacecraft measure as a result of time dilation?
26. An alien spacecraft speeds through the solar system at  $0.8c$ .  
 (a) What is the effect of its speed on the length of the spacecraft from the perspective of an alien on board?  
 (b) What is the effect of its speed on the length of the spacecraft from the perspective of the Sun?  
 (c) At what speed does light from the Sun reach it?
27. A high-energy physicist detects a particle in a particle accelerator that has a half-life of 20 s when travelling at  $0.99c$ .  
 (a) Calculate the particle's half-life in its rest frame.  
 (b) The detector is 5 m long. How long would it be in the rest frame of the particle?
28. It takes 5 min for an astronaut to eat his breakfast, according to the clock on his spacecraft. The clock on a passing spacecraft records that 8 min passed while he ate his breakfast.  
 (a) Which time is proper time?  
 (b) What is the relative speed of the two spacecraft?
29. The nearest star, apart from the Sun, is 4.2 light-years distant.  
 (a) How far is it to that star according to astronauts in a spacecraft travelling at  $0.7c$ ?  
 (b) How long would it take to get there in this spacecraft?  
 (c) How long will the journey take, based on measurements from Earth? (Assume that Earth is stationary relative to the star.)
30. A spacecraft ( $L_0 = 80 \text{ m}$ ) travels past a space station at speed  $0.7c$ . Its radio receiver is on the tip of its nose. The space station sends a radio signal the instant the tail of the spacecraft passes the space station.  
 (a) What is the length of the spacecraft in the reference frame of the space station?  
 (b) How far from the space station is the nose of the spacecraft when it receives the radio signal from the reference frame of the space station?  
 (c) What is the time taken for the radio signal to reach the nose of the spacecraft, according to those on the space station?  
 (d) What is the time taken for the radio signal to reach the nose, according to those on the spacecraft?
31. An astronaut on a space walk sees a spacecraft passing at  $0.9c$ . The spacecraft has a proper length of 100 m. What is the length of the spacecraft  $L$  due to length contraction according to the astronaut?
32. Explain why muons reach the surface of the Earth in greater numbers than would be predicted by classical physics given their speed, their half-lives and the distance they need to travel through the atmosphere.

33. A muon forms 30 km above the Earth's surface and travels straight down at  $0.98c$ . From its frame of reference, what is the distance it has to travel through the atmosphere?
34. The proper time for the half-life of a muon is 1.56 microseconds. If the muon moves at  $0.98c$  relative to an observer, what does the observer measure its half-life as?
35. Explain how muons produced by cosmic rays became an early confirmation of special relativity.

### Mass–energy and relativity

36. Use your knowledge of relativity to argue that matter cannot travel at the speed of light.
37. How much energy would be required to accelerate 1000 kg to:
- $0.1c$
  - $0.5c$
  - $0.8c$
  - $0.9c$
38. Sketch a graph of energy versus speed using your answers to the previous question.
39. Travelling at near light speed would enable astronauts to cover enormous distances. Explain the difficulties in terms of energy of achieving space travel at near light speed.
40. Which of the following would be a consequence of the relativistic mass increase of a person travelling past you at near light speed?
- They would appear physically larger.
  - They would weigh more on a balance.
  - They would require more force to accelerate.

$$E = mc^2$$

41. Explain in words what  $E = mc^2$  tells us about energy and mass.
42. An astronaut in a spacecraft moves past Earth at  $0.8c$  and measures his mass. (He has no weight in his inertial reference frame.) According to him, his mass is 70 kg.
- What is his mass according to an observer on Earth?
  - How much energy was required to give him the extra mass?
43. Calculate the rest energy of Earth, which has a rest mass of  $6.0 \times 10^{24}$  kg.
44. Consider Earth to be a mass moving at  $30 \text{ km s}^{-1}$  relative to a stationary observer. Given that the rest mass of Earth is  $5.98 \times 10^{24}$  kg, what would be the difference between this rest mass and the mass from the point of view of the stationary observer?
45. Calculate the kinetic energy of a 10 000 kg asteroid travelling at  $0.6c$ .
46. Calculate the speed of a 10 kg meteorite that has  $5.0 \times 10^8$  J of kinetic energy.
47. If a 250 g apple could be converted into electricity with 100% efficiency, how many joules of electricity would be produced?
48. Much of Victoria's electricity is produced by burning coal. What can you say about the mass of the coal and its chemical combustion products as a result of burning it?
49. What would have greater rest mass, the Moon in orbit about Earth, or the Moon separated from Earth?
50. What is happening to the mass of the Sun over time? Why?
51. Part of the fusion process in the Sun involves the fusion of two protons into a deuteron. This results in the release of 0.42 MeV of energy. What is the mass equivalent of this energy release?
52. Where in the fusion processes in the Sun is electromagnetic radiation produced that is later radiated by the Sun?
53. (a) Write the most common sequence of nuclear fusion reactions in the Sun.  
 (b) How does the total mass of the particles on the left-hand side of the arrow in each equation compare with the total mass of the particles on the right-hand side?



## REMEMBER

Before beginning this chapter, you should be able to:

- model forces as vectors acting at the point of application (with magnitude and direction), labelling these forces using the convention ‘force on A by B’ or  $F_{\text{on A by B}}$
- model the force due to gravity,  $F_g$ , as the force of gravity acting at the centre of mass of a body
- apply Newton’s three laws of motion to a body on which forces act:  $a = \frac{F_{\text{net}}}{m}$ ,  $F_{\text{on A by B}} = -F_{\text{on B by A}}$
- analyse uniform circular motion in a horizontal plane
- resolve vectors into components
- apply the energy conservation model to energy transfers and transformations.

## KEY IDEAS

After completing this chapter, you should be able to:

- apply Newton’s Law of Universal Gravitation to the motion of planets and satellites

- describe gravitation using a field model
- describe the gravitational field around a point mass in terms of its direction and shape
- calculate the strength of the gravitational field at a point a distance,  $r$ , from a point mass
- analyse the motion of planets and satellites by modelling their orbits as uniform circular orbital motion
- describe potential energy changes of an object moving in the gravitational field of a point mass
- analyse energy transformations as objects change position in a changing gravitational field, using area under a force–distance graph and area under a field–distance graph multiplied by mass
- apply the concepts of force due to gravity,  $F_g$ , and normal reaction force,  $F_N$ , to satellites in orbit.

Understanding gravitational forces has allowed us to put satellites in orbit around the Earth.



## Explaining the solar system

Isaac Newton (1642–1726) published his Law of Universal Gravitation in 1687. This law provided a mathematical and physical explanation for several important observations about the movement of planets in the solar system that had been made over the previous two centuries.

In 1542, Nicolas Copernicus (1473–1543) published 'On the Revolution of the Heavenly Orbs', outlining an explanation for the observations of planetary motion with the Sun at the centre. In his explanation, the planets moved in circular orbits about the Sun. Copernicus's model became increasingly preferred over the geocentric model of Ptolemy because it made astronomical and astrological calculations easier. The publication had a significant scientific, social and political impact during the latter part of the 16th century.

Galileo Galilei (1564–1642) was a strong advocate for the view that the Copernican model was more than 'a set of mathematical contrivances, merely to provide a correct basis for calculation' and instead represented physical reality. (This had also been Copernicus's view, but he could not express this in print.) Galileo thought that astronomy could now ask questions about the structure, fabric and operation of the heavens, but as with so many of his scientific interests, Galileo did not pursue these questions further.

Johannes Kepler (1571–1630) decided his purpose in life was to reveal the fundamental coherence of a planetary system with the sun as its centre. In 1600–1601 he was working an assistant to Tycho Brahe (1546–1601), a Danish astronomer who had been compiling very precise measurements of the planets' positions for over twenty years. Brahe's data was so accurate that they are still valid today. Without the aid of a telescope, he was able to measure angles to an accuracy of half a minute of arc (for example  $23^{\circ}34' \pm 0.5'$ ).

Kepler was seeking to find patterns and relationships between motion of the various planets. He used the data to calculate the positions of the planets as they would be observed by someone outside the solar system, rather than from the revolving platform of the Earth. Initially he was looking for circular orbits, but Brahe's precise data did not fit such orbits. Eventually he tried other shapes, until in 1604 he formulated what is known as Kepler's First Law:

*Each planet moves, not in a circle, but in an ellipse, with the sun, off centre, at a focus.*

An ellipse is like a stretched circle. The shape can be drawn by placing two pins on the page several cm apart, with a loose piece of string tied between the pins. If a pencil is placed against the string to keep it tight and then the pencil is moved around the page, the drawn shape is an ellipse with a focus at each of the pins. The closer the two foci, the more like a circle the ellipse becomes.

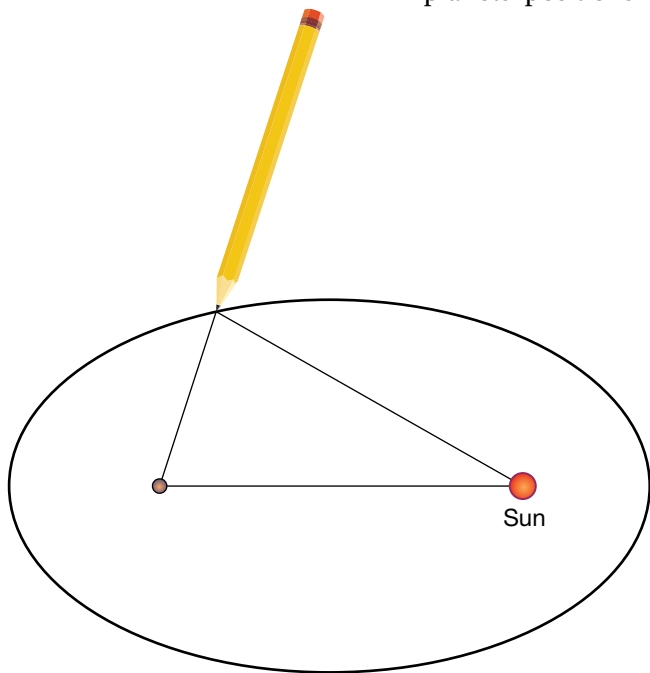

Drawing an ellipse

### Evidence of elliptical orbits

The equinoxes are the two days in the year when the sun is directly above the equator and the durations of night and day are equal. They occur when the line drawn from the Sun to the Earth is at right angles to the Earth's orbit. Because the Earth's orbit is an ellipse, when the Sun is off centre at one of the two foci, these two points are not directly opposite each other. This means the time for the Earth to go from the March equinox to the September equinox is longer by a few days than the time to go from the September equinox to the March equinox.

Look up the dates of the March and September equinoxes and determine the two times between them.

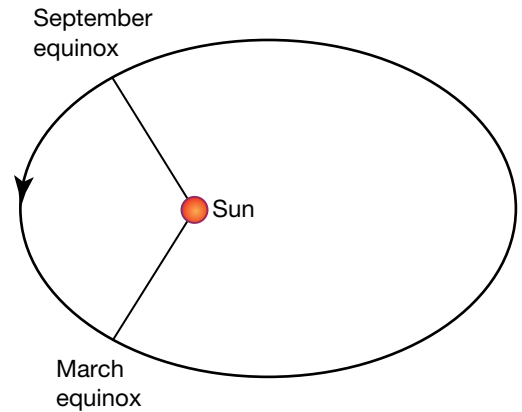

Location of the two equinoxes in the Earth's orbit

There was much speculation in Newton's time that gravitational attraction might vary inversely with the square of the distance, but it was Newton who was able to show mathematically, using a geometric proof, that the Earth's elliptical orbit means that the inverse square law applies to the attraction between the Sun and the Earth.

### eBookplus

eLesson  
Kepler's laws  
eles-2557

## Kepler's Second Law

Kepler also looked at the speed of the planets in their orbits. His analysis of the data showed that speeds of the planets were not constant. The planets were slower when they were further away from the sun and faster when closer. He also found that their angular speed, the number of degrees a line from the sun to planet sweeps through every day, was not constant. Both results reinforced his first law. However, he did find in 1609 that the planets sweep out equal areas with time.

Kepler's Second Law: *The linear speed and angular speed of a planet are not constant, but the areal speed of each planet is constant.* That is, a line joining the sun to a planet sweeps out equal areas in equal times.

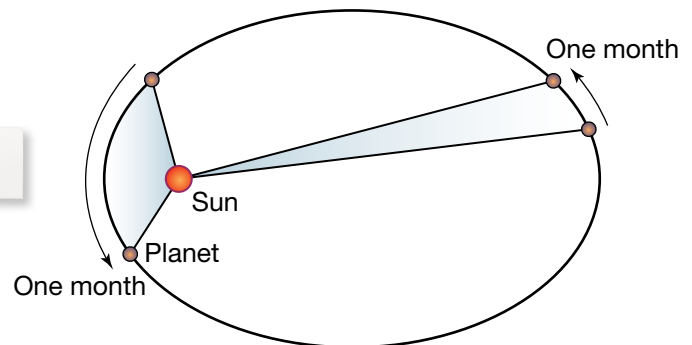

Kepler's Second Law

Newton was able to show mathematically that a constant areal velocity meant that the force acting on a planet must always act along the line joining the planet to the Sun.

## Kepler's Third Law

Kepler was keen to find a mathematical relationship between the period of a planet's orbit around the sun and its average radius that gave the same result for each planet. He tried numerous possibilities and eventually in 1619 he found a relationship that fitted the data.

Kepler's Third Law: *For all planets, the cube of the average radius is proportional to the square of the orbital period; that is,  $\frac{R^3}{T^2}$  is a constant for all planets going around the sun.*

Kepler was also able to show that the relationship held for the orbits of the moons of Jupiter.

Kepler had constructed as detailed a description of the solar system as was possible without a mechanism to explain the motion of the planets, although he did understand gravity as a reciprocal attraction. Kepler wrote, “Gravity is the mutual tendency between bodies towards unity or contact (of which the magnetic force also is), so that the Earth draws a stone much more than the stone draws the Earth...”

**TABLE 4.1** The solar system: some useful data

Body	Mass (kg)	Radius of body (m)	Mean radius of orbit (m)	Period of revolution (s)
Sun	$1.99 \times 10^{30}$	$6.96 \times 10^8$	Not applicable	Not applicable
Earth	$5.97 \times 10^{24}$	$6.37 \times 10^6$	$1.50 \times 10^{11}$	$3.16 \times 10^7$
• Moon	$7.35 \times 10^{22}$	$1.74 \times 10^6$	$3.84 \times 10^8$	$2.36 \times 10^6$
Mercury	$3.30 \times 10^{23}$	$2.44 \times 10^6$	$5.79 \times 10^{10}$	$7.60 \times 10^6$
Venus	$4.87 \times 10^{24}$	$6.05 \times 10^6$	$1.08 \times 10^{11}$	$1.94 \times 10^7$
Mars	$6.42 \times 10^{23}$	$3.40 \times 10^6$	$2.28 \times 10^{11}$	$5.94 \times 10^7$
Jupiter	$1.90 \times 10^{27}$	$7.15 \times 10^7$	$7.78 \times 10^{11}$	$3.74 \times 10^8$
Saturn	$5.68 \times 10^{26}$	$6.03 \times 10^7$	$1.43 \times 10^{12}$	$9.29 \times 10^8$
Uranus	$8.68 \times 10^{25}$	$2.59 \times 10^7$	$2.87 \times 10^{12}$	$2.64 \times 10^9$
Neptune	$1.02 \times 10^{26}$	$2.48 \times 10^7$	$4.50 \times 10^{12}$	$5.17 \times 10^9$
Pluto*	$1.46 \times 10^{22}$	$1.18 \times 10^6$	$5.90 \times 10^{12}$	$7.82 \times 10^9$

\*Pluto is no longer classified as a planet. Scientists have recently hypothesised that a ninth planet may exist, but it has not yet been directly observed.

### Revision question 4.1

Use the data in table 4.1 to calculate the value of  $\frac{R^3}{T^2}$  for each of the planets in the solar system and therefore confirm Kepler’s Third Law.

### study on

Unit 3

**Newton’s Law of Universal Gravitation**

AOS 1

Topic 1

Concept summary and practice questions

Concept 1

## Newton’s Law of Universal Gravitation

Newton combined his deductions from Kepler’s Laws with his own Laws of Motion to develop an expression for a law of universal gravitation.

From Kepler’s first law, Newton had determined that the force on a planet was inversely proportional to the square of the distance.

$$F_{\text{on planet by Sun}} \propto \frac{1}{R^2}$$

Using his second law of motion,  $F_{\text{net}} = ma$ , Newton reasoned that the force  $F_{\text{on planet by Sun}}$  depended on the mass of the planet. By using his third law of motion,  $F_{\text{on planet by Sun}} = -F_{\text{on Sun by planet}}$ , he reasoned that the force  $F_{\text{on Sun by planet}}$  depended on the mass of the sun.

Combining these two statements produces:

$$\text{Gravitational force between the sun and the planet} \propto \text{Mass}_{\text{Sun}} \times \frac{\text{Mass}_{\text{planet}}}{R^2}.$$

In general,

$$F = \frac{Gm_1m_2}{R^2}$$

where  $G$  is the universal gravitational constant and  $m_1$  and  $m_2$  are the masses of any two objects.

The value of  $G$  could not be determined at the time because the mass of the Earth was not known. It took another 130 years before Henry Cavendish was able to measure the gravitational attraction between two known masses and calculate the value of  $G$ .

The value of  $G$  is  $6.674 \times 10^{-11} \text{ N m}^2 \text{ kg}^{-2}$ . Alternatively, replacing newtons with  $\text{kg m s}^{-2}$ ,  $G = 6.674 \times 10^{-11} \text{ m}^3 \text{ kg}^{-1} \text{ s}^{-2}$ .

The value of  $G$  is very small, which indicates that gravitation is quite a weak force. A large quantity of mass is needed to produce a gravitational effect that is easily noticeable.

### Sample problem 4.1

Calculate the force due to gravity of:

- (a) Earth on a 70 kg person standing on the equator
- (b) a 70 kg person standing on the equator on Earth.

**Solution:** (a)  $m_{\text{Earth}} = 5.98 \times 10^{24} \text{ kg}$ ,  $m_{\text{person}} = 70 \text{ kg}$ ,  $\text{radius}_{\text{Earth}} = 6.38 \times 10^6 \text{ m}$ ,

$$G = 6.67 \times 10^{-11} \text{ N m}^2 \text{ kg}^{-2}$$

$$\begin{aligned} F &= \frac{Gm_{\text{Earth}}m_{\text{person}}}{r^2} \\ &= \frac{6.67 \times 10^{-11} \text{ N m}^2 \text{ kg}^{-2} \times 5.98 \times 10^{24} \text{ kg} \times 70 \text{ kg}}{(6.38 \times 10^6 \text{ m})^2} \\ &= 686 \text{ N towards the centre of Earth} \end{aligned}$$

- (b) Newton's Third Law of Motion states that if one object exerts a force on another object, then the other object exerts an equal and opposite force on the first object. In this situation, if Earth is exerting a force of 686 N downwards on the person, then the person is exerting a 686 N force upwards on Earth! The same result could be calculated with the formula used in part (a).

### Revision question 4.2

Use the data in table 4.1 to calculate the force due to gravity by:

- (a) the Earth on the Moon
- (b) the Moon on Earth.

### The falling apple

Newton published his law of universal gravitation in 1687, in his famous book titled *Philosophiæ Naturalis Principia Mathematica*. In this book he included an anecdote about observing an apple falling from a tree. There is no record of such an event in his earlier papers, so the story may just have served an explanatory purpose. Nevertheless, the story is instructive.

Newton said he observed that the falling apple had been pulled from the tree by the attractive force of the Earth, which had acted across the space between the Earth's surface and the apple, that is, 'action at a distance'. He speculated that the effect of the Earth's pull might reach higher into the atmosphere, possibly beyond the atmosphere to the moon. He had previously applied his Laws of Motion to circular motion and developed expressions for the inward acceleration,

$$a = \frac{v^2}{R} \quad \text{and} \quad a = \frac{4\pi^2 R}{T^2}.$$

The obvious questions that arise from this are:

1. How does the acceleration of the apple compare to that of the moon?
2. How are these two values related to their respective distances from the centre of the Earth?

**TABLE 4.2** The relationship between the Earth, an apple and the Moon

Body	Apple	Moon
Distance to the centre of the Earth (m)	$6.38 \times 10^6$	$3.84 \times 10^8$
Period of orbit (s)		$2.36 \times 10^6$
Acceleration towards the centre of the Earth ( $\text{m s}^{-2}$ )	$9.8 \text{ m s}^{-2}$	$2.72 \times 10^{-3}$

With the data from the table, we can make the following calculations:

$$\frac{\text{distance of the Moon from the centre of the Earth}}{\text{distance of the apple from the centre of the Earth}} = \frac{3.84 \times 10^8}{6.38 \times 10^6} = 60.1$$

$$\frac{\text{acceleration of the apple towards the centre of the Earth}}{\text{acceleration of the Moon towards the centre of the Earth}} = \frac{9.8}{2.72 \times 10^{-3}} = 3603$$

The value of the second ratio, 3603, is very close to  $60.1^2$ .

The ratio of the accelerations is the square of the ratio of the distances, but note that the Moon is in the numerator for the first ratio, while it is in the denominator for the second ratio. Newton used this calculation to show that the gravitational force is inversely proportional to the square of the separation of the two masses.

Newton's expression for the centripetal acceleration,  $a = \frac{4\pi^2 R}{T^2}$ , was used to confirm Kepler's Third Law, that  $\frac{R^3}{T^2}$  is a constant for all planets or satellites orbiting a central body.

$$F_{\text{net}} = F_g$$

$$m_{\text{planet}} \times \frac{4\pi^2 R}{T^2} = \frac{GM_{\text{Sun}} m_{\text{planet}}}{R^2}$$

Cancelling  $m_{\text{planet}}$  and rearranging gives

$$\frac{R^3}{T^2} = \frac{GM_{\text{Sun}}}{4\pi^2}$$

which depends only on the mass of the Sun and thus has the same value for all planets orbiting the Sun.

Similarly, the Moon and all other satellites orbiting the Earth will have the same value for  $\frac{R^3}{T^2}$ , though in this case the value will equal  $\frac{GM_{\text{Earth}}}{4\pi^2}$ .

### Sample problem 4.2

Calculate the value of  $\frac{R^3}{T^2}$  for the Moon using the data in table 4.1 and use that value to calculate the mass of the Earth.

**Solution:** Radius of Moon's orbit,  $R = 3.84 \times 10^8 \text{ m}$ ; period,  $T = 2.36 \times 10^6 \text{ s}$ ;  
 $G = 6.67 \times 10^{-11} \text{ Nm}^2 \text{ kg}^{-2}$ ; mass of Earth,  $M_{\text{Earth}} = ?$

$$\frac{R^3}{T^2} = \frac{(3.84 \times 10^8 \text{ m})^3}{(2.36 \times 10^6 \text{ s})^2}$$

$$= 1.02 \times 10^{13} \text{ m}^3 \text{ s}^{-2}$$

$$\text{Using } \frac{R^3}{T^2} = \frac{GM_{\text{Earth}}}{4\pi^2},$$

$$\begin{aligned} M_{\text{Earth}} &= \frac{R^3}{T^2} \times \frac{4\pi^2}{G} \\ &= \frac{(3.84 \times 10^8 \text{ m})^3 \times 4\pi^2}{(2.36 \times 10^6 \text{ s})^2 \times 6.67 \times 10^{-11} \text{ N m}^2 \text{ kg}^{-2}} \\ &= 6.02 \times 10^{24} \text{ kg}. \end{aligned}$$

### Revision question 4.3

Find the average of the values of  $\frac{R^3}{T^2}$  that you calculated in revision question 4.1.

Use that average value to calculate the mass of the Sun.

Newton's Law of Universal Gravitation can also be used to calculate the average speed of planets around the Sun. This involves using the other expression for the centripetal acceleration.

$$\begin{aligned} F_{\text{net}} &= F_g \\ m_{\text{planet}} \times \frac{v^2}{R} &= \frac{GM_{\text{Sun}}m_{\text{planet}}}{R^2} \end{aligned}$$

Cancelling  $m_{\text{planet}}$  and rearranging gives

$$\begin{aligned} v^2 &= \frac{GM_{\text{Sun}}}{R} \\ v &= \sqrt{\frac{GM_{\text{Sun}}}{R}}. \end{aligned}$$

### Sample problem 4.3

Calculate the average speed of the Earth around the Sun using the values in table 4.1.

**Solution:** Radius of Earth's orbit,  $R = 1.50 \times 10^{11} \text{ m}$ ; mass of Sun,  $M_{\text{Sun}} = 1.98 \times 10^{30} \text{ kg}$ ;  $G = 6.67 \times 10^{-11} \text{ N m}^2 \text{ kg}^{-2}$ ; speed,  $v = ?$

$$\begin{aligned} \text{Using } v &= \sqrt{\frac{GM_{\text{Sun}}}{R}}, \\ v &= \sqrt{\frac{6.67 \times 10^{-11} \text{ N m}^2 \text{ kg}^{-2} \times 1.98 \times 10^{30} \text{ kg}}{1.50 \times 10^{11} \text{ m}}} \\ &= 2.97 \times 10^4 \text{ m s}^{-1}. \end{aligned}$$

### Revision question 4.4

Use the values in table 4.1 to calculate the average speed of the other planets around the Sun. Graph the average speed as a function of average orbital radius. Does the graph fit your expectation? Are there any outliers in the data? If so, suggest an explanation.

### Graphing the gravitational force

The gravitational force is an attractive force, whereas the force between electric charges can be either attractive or repulsive.

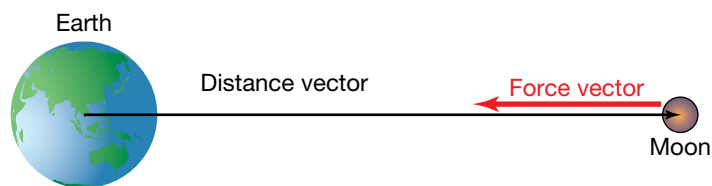

The Earth exerts gravitational force on the Moon.

For the force the Earth exerts on the Moon, there is a distance vector from the centre of the Earth to the centre of the Moon, whereas the force vector points in the opposite direction, back to the Earth. For this reason, the gravitational force equation should really have a negative sign and the force should be graphed under the distance axis. Thus, more correctly,

$$F_g = -\frac{Gm_1m_2}{R^2}.$$

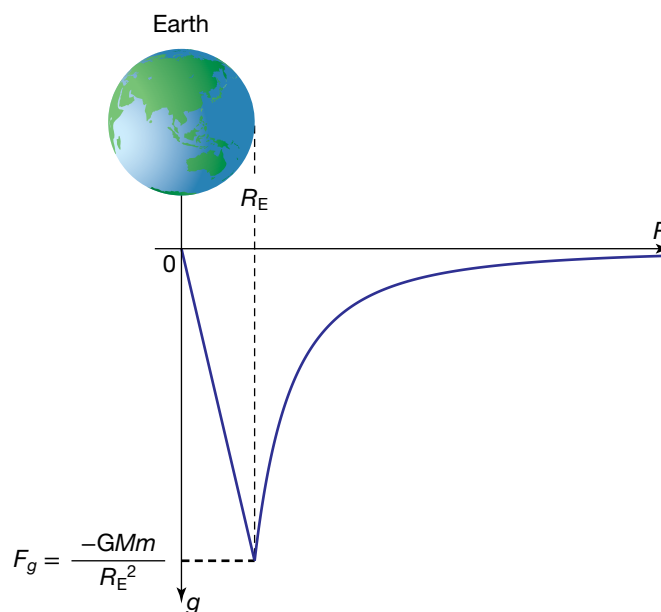

This diagram shows how the Earth's gravitational force varies with distance.

### eBookplus

#### Interactivity

One giant leap...  
int-6611

The straight blue line in the graph shows how the gravitational force by the Earth on you would decrease if you were to drill down to the centre of the earth. Newton calculated that if you were inside a hollow sphere, the gravitational force from the mass in the shell would cancel out, no matter where you were inside the sphere. This means that if you were inside the Earth, only the mass in the inner sphere between you and the centre of the Earth would exert a gravitational force on you. This force will get smaller the closer to the centre you go, and at the centre of the Earth the gravitational force will be zero.

## Gravitational fields

Newton's Law of Universal Gravitation describes the force between two masses. However, the solar system has many masses, each attracting each other. The sun, the heaviest object in the solar system, determines the orbits of all the other masses, but each planet can cause minor variations in the orbital paths of the other planets. Precise calculation of the path of a planet or comet



becomes a complicated exercise with many gravitational forces needing to be considered.

Physicists after Newton realised it was easier to determine for each point in space the total force that would be experienced by a unit mass, that is, 1 kilogram, at that point. This idea slowly developed and in 1849 Michael Faraday, in explaining the interactions between electric charges and between magnets, formalised the concept, calling it a 'field'.

A field is more precisely defined as a physical quantity that has a value at each point in space. For example, a weather map showing the pressure across Australia could be described as a diagram of a pressure field. This is an example of a scalar field. In contrast, gravitational, electric and magnetic fields are vector fields; they give a value to the strength of the field at each point in space, and also a direction for that field at that point. For example, the arrows in the diagram of the Earth's gravitational field show the direction of the field, and the density of the lines (how close together the lines are) indicates the strength of the field.

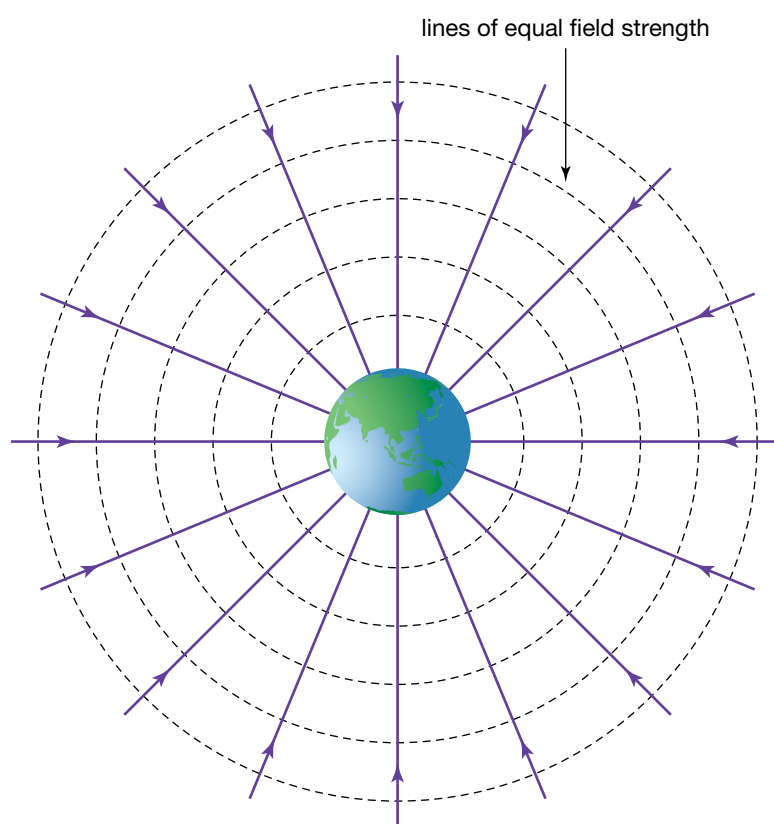

Diagram of the Earth's gravitational field

A value for the strength of the gravitational field around a mass  $M$  can be determined from the value of the force on a unit mass in the field. If the mass  $m_2$  in Newton's Universal Law of Gravitation equation is assigned a value of 1 kg, then the force expression will give the strength of the gravitational field.

$$\text{Gravitational field strength, } g = -\frac{GM}{R^2}$$

The unit of gravitational field strength is Newtons per kilogram,  $\text{N kg}^{-1}$ .

**study on**

Unit 3

**Gravitational field strength**

AOS 1

Concept summary and practice questions

Topic 1

Concept 2

The strength of the gravitational field at the Earth's surface can be calculated using the values for the mass and radius of the Earth from table 4.1:

$$\begin{aligned} \text{Gravitational field strength, } g &= -\frac{6.67 \times 10^{-11} \text{ N m}^2 \text{ kg}^{-2} \times 5.98 \times 10^{24}}{(6.38 \times 10^6)^2} \\ &= -9.80 \text{ N kg}^{-1}. \end{aligned}$$

This is the acceleration due to gravity at the Earth's surface.

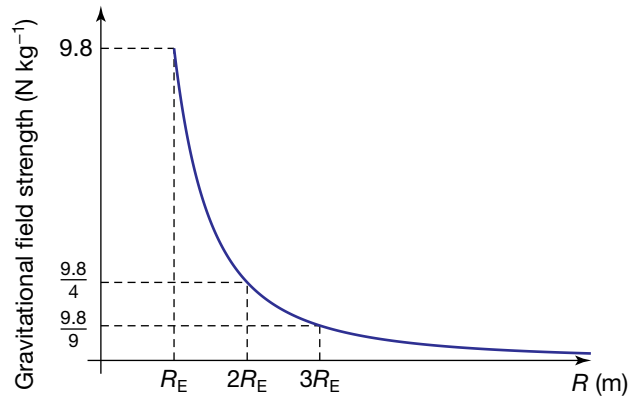

Graph of the magnitude of the strength of the Earth's gravitational field

#### Revision question 4.5

- Use the data in table 4.1 to calculate the gravitational field strength on the surface of the Moon. Show that it is about  $\frac{1}{6}$  of the Earth's gravitational field at its surface.
- Determine which planet has the largest gravitational field strength at its surface. Table 4.1 is also available as a spreadsheet in your eBookPLUS.

At the time Newton developed his Law of Universal Gravitation, he knew it did not provide an explanation for how gravity works, that is, how 'action at a distance' was achieved.

*It is inconceivable... that Gravity should be innate, inherent and essential to Matter, so that one body may act upon another at a distance thro' a Vacuum, without the Mediation of any thing else... is to me so great an Absurdity that I believe no Man who has in philosophical Matters a competent Faculty of thinking can ever fall into it. Gravity must be caused by an Agent acting constantly according to certain laws; but whether this Agent be material or immaterial, I have left to the Consideration of my readers. Newton, 1692*

The concept of a field now provides an explanation for action at a distance.

#### study on

**Unit 3**  
**AOS 1**  
**Topic 1**  
**Concept 5**

**Gravitational potential energy**  
Concept summary and practice questions

#### Kinetic energy and potential energy in a gravitational field

Consider the following scenarios.

- On 15 February 2013, an asteroid approached the Earth, gaining speed in the Earth's gravitational field. By the time it reached the atmosphere, it was travelling at a speed of  $19 \text{ km s}^{-1}$ . With a mass of about  $1.2 \times 10^7 \text{ kg}$ , its kinetic energy was about  $2.2 \times 10^{15} \text{ J}$ . It exploded about 30 km above Chelyabinsk in Russia.

2. Edmund Halley used Newton's law of gravitation to calculate the effect of Jupiter and Saturn on the orbits of comets. He concluded that comet sightings in 1531 and 1607 were sightings of the same comet and that it should appear again in 1758. We now call it Halley's Comet.

Halley's Comet orbits the sun every 75.3 years in a very stretched path. The closest it gets to the Sun is about 0.6 times the radius of the Earth's orbit, while its furthest distance is 35 times the radius. At its closest approach its kinetic energy is  $1.6 \times 10^{23}$  J with a speed of  $38 \text{ km s}^{-1}$ , but at its furthest it has only  $4.5 \times 10^{19}$  J, travelling at  $0.64 \text{ km s}^{-1}$ .

3. Ignoring the initial air resistance, a rock thrown at  $11 \text{ km s}^{-1}$  would eventually escape the effect of the Earth's gravitational pull, slowing down to zero only at an infinite distance away.

In each of these scenarios there are changes in speed and height, and thus in kinetic energy and gravitational potential energy. How do we describe these changes using Newton's law of gravitation?

The change in gravitational potential energy can be obtained from the area under a force–distance graph. Because gravitation is an attractive force, the force–distance graph is below the distance axis and the area under the graph has a negative value.

Change in potential energy needs a reference point or zero point. The Earth's surface is an obvious reference point for objects on or near the Earth; we can assume a constant value of  $9.8 \text{ N kg}^{-1}$  for the strength of the gravitational field at the Earth's surface. But out in space, with the gravitational force getting weaker with distance, the preferred reference point is at infinity where the gravitational force is zero. This means that the gravitational potential energy of a mass at a distance  $R$  from the Earth is the area under the graph from the distance  $R$  out to infinity.

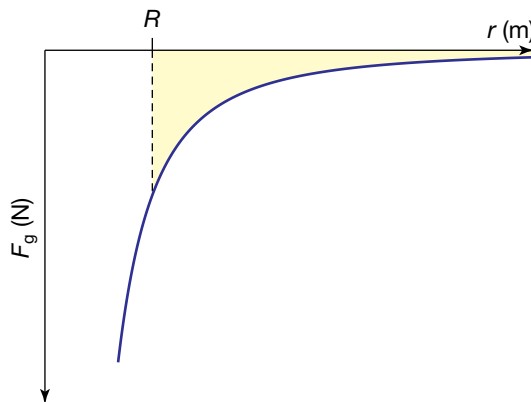

Graph of the strength of the Earth's gravitational force. The gravitational potential energy of a mass at distance  $R$  from the Earth is equal to the shaded area.

Let's look at situation 1, the Chelyabinsk asteroid. When the asteroid is some distance from Earth, its kinetic energy is relatively small. As it falls towards the Earth, its kinetic energy increases, its gravitational potential energy becomes more negative, and the total energy remains the same throughout. As the asteroid falls from A to B in the figures on the following page, the orange shaded area in the third graph is the gain in kinetic energy. That is,

$$\text{change in GPE} = \text{change in KE.}$$

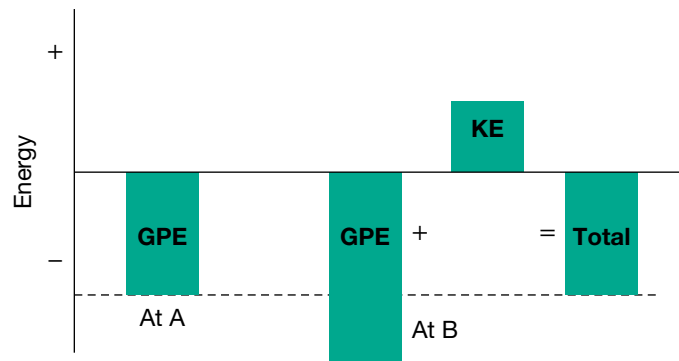
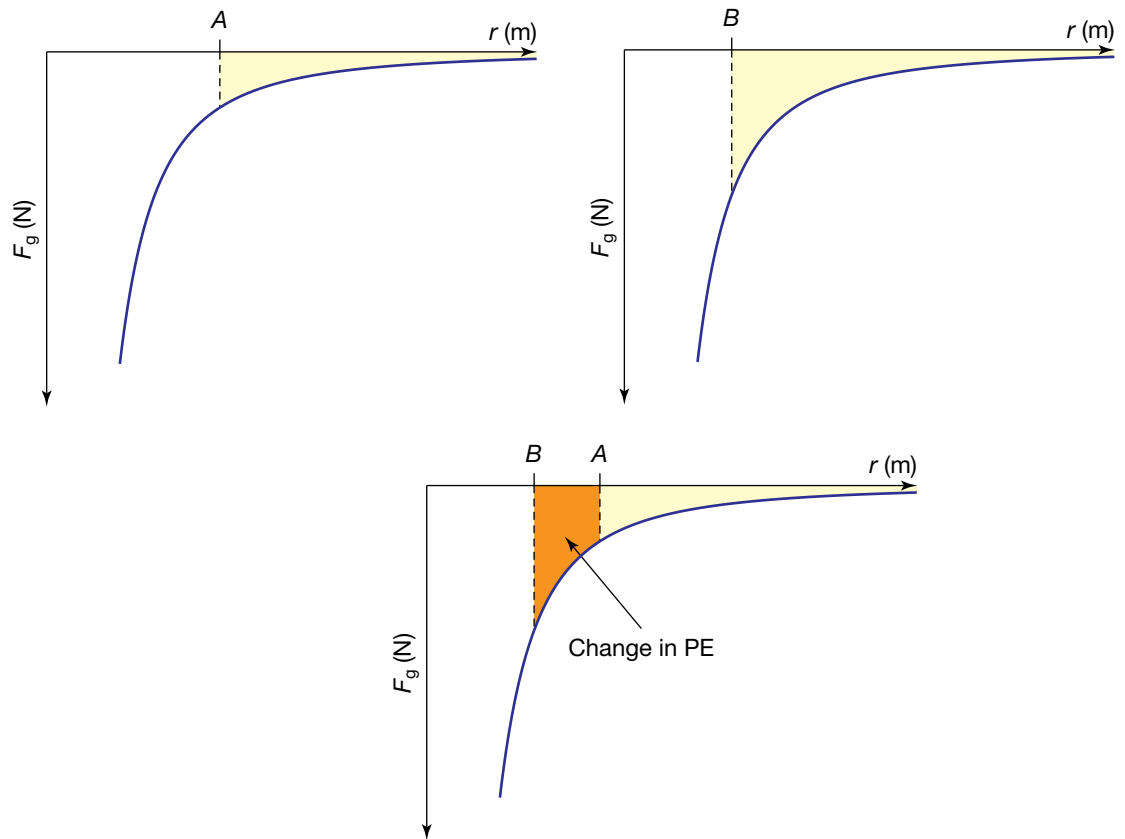

The total energy at B equals the total energy at A.

#### Sample problem 4.4

A mass of 10 kg falls to the surface of the Earth from an altitude equal to two Earth radii. What is the gain in kinetic energy?

**Solution:** There are three methods, two of which give an approximate answer. The accuracy of each depends on the care you take.

##### Method 1

Use this method if the graph has a relatively coarse grid.

- Divide the area up into simple geometric shapes such as rectangles and triangles.
- Calculate the area of each shape using graph-based units.

- Total the areas.
- Convert the total area to SI units for energy.

Take care in deciding the height of the rectangles or triangles so that their areas (approximating the area under the curve) will produce more representative results.

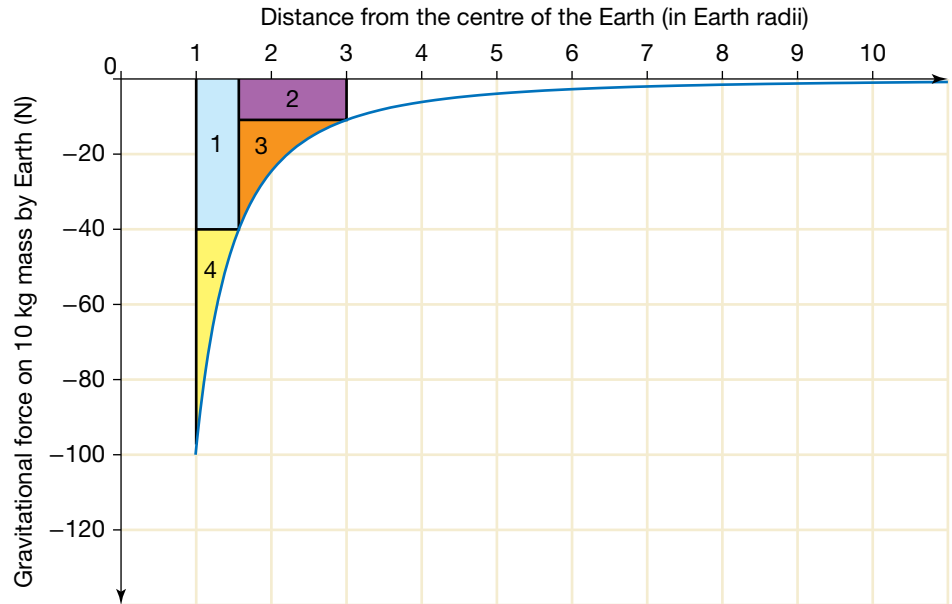

$$\begin{aligned} \text{Area 1 (blue)} &= 40 \times 0.5 \\ &= 20 \text{ energy units} \end{aligned}$$

$$\begin{aligned} \text{Area 2 (purple)} &= 10 \times 1.5 \\ &= 15 \text{ energy units} \end{aligned}$$

$$\begin{aligned} \text{Area 3 (orange)} &= \frac{1}{2} \times 24 \times 1.5 \\ &= 18 \text{ energy units} \end{aligned}$$

(Note: The triangle with area  $\frac{1}{2} \times 30 \times 1.5$  would be larger than the orange area, so the height of 30 was reduced to a level where the areas matched.)

$$\begin{aligned} \text{Area 4 (yellow)} &= \frac{1}{2} \times 53 \times 0.5 \\ &= 13.25 \text{ energy units} \end{aligned}$$

$$\begin{aligned} \text{Total area} &= 20 + 15 + 18 + 13.25 \\ &= 66.25 \text{ energy units} \end{aligned}$$

$$\begin{aligned} 1 \text{ energy unit} &= 1 \text{ N} \times 1 \text{ Earth radius} \\ &= 1 \text{ N} \times 6.38 \times 10^6 \text{ m} \\ &= 6.38 \times 10^6 \text{ J} \end{aligned}$$

$$\begin{aligned} \text{Therefore, the kinetic energy gained} &= 66.25 \times 6.38 \times 10^6 \\ &= 4.23 \times 10^8 \text{ J.} \end{aligned}$$

### Method 2

Use this method when the graph has a relatively fine grid.

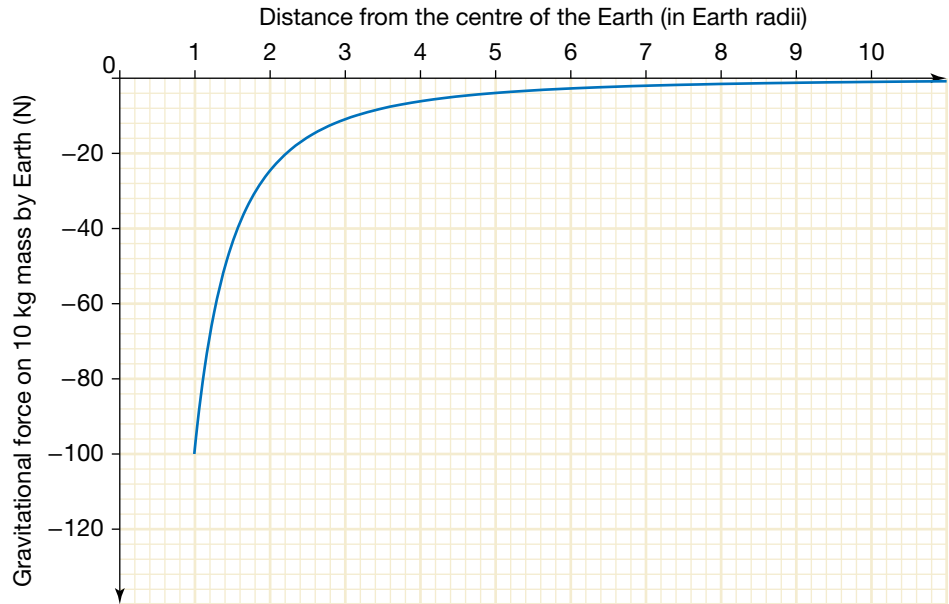

- Count the number of small squares between the graph and the zero-value line or horizontal axis. Tick each one as you count it to avoid counting it twice. For partial squares, find two that add together to make one square and tick both.
- Calculate the area of one small square.
- Multiply the area of one small square by the number of small squares.

Number of small squares = 80.5

$$\begin{aligned}\text{Area of one small square} &= 4 \text{ N} \times 0.2 \times 1 \text{ Earth radius} \\ &= 4 \text{ N} \times 0.2 \times 6.38 \times 10^6 \text{ m} \\ &= 5.1 \times 10^6 \text{ J}\end{aligned}$$

Therefore, the gain in kinetic energy =  $80.5 \times 5.1 \times 10^6 \text{ J} = 4.11 \times 10^8 \text{ J}$ .

Method 2 can be very accurate, but it is laborious.

### Method 3

- Print out the graph.
- Cut out the required shape.
- Measure the mass of the shape with a top-loading balance.
- Using the mass of a piece of the same paper with known dimensions, calculate the area of the cut-out shape.
- Use the scales on the axes of the graph to determine the value for the area under the graph.

### Revision question 4.6

- Use the graph of the gravitational force on the Chelyabinsk asteroid (shown on the next page) to show that in moving from an altitude of two Earth radii down to an altitude of one Earth radius, it gained  $1.25 \times 10^{14}$  joules of kinetic energy.
- Use the graph to find, to the nearest whole number, approximately how much kinetic energy was gained from falling from an altitude of one Earth radius to the Earth's surface. Compare this value with your answer to (a) above.

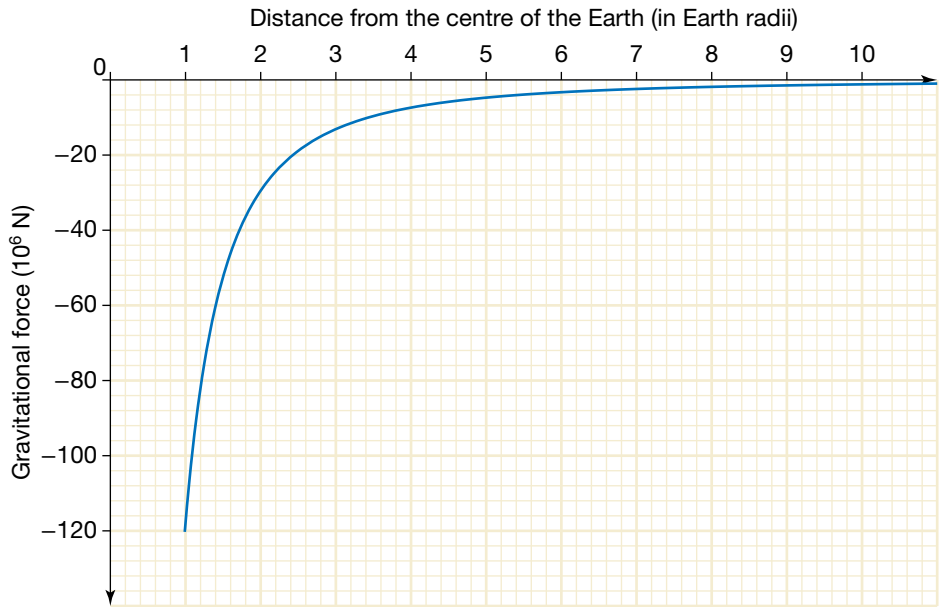

Gravitational force exerted on the Chelyabinsk asteroid by the Earth

### Using the area under a field graph

The graphs for the 10 kg mass and the Chelyabinsk asteroid have different values on the force axis. To find the changes in energy of a rock escaping the Earth, a different graph would be needed, because the mass of the rock is different, and thus the gravitational force on it is different. It would be simpler if we could use the same graph for different objects regardless of their mass.

The graph that can be used for this purpose is a graph of the gravitational field against distance. The gravitational force on a mass at a point in space is just the value of the gravitational field at the point times its mass. Similarly, the change

in energy for an object that moves from one point to another can be obtained by multiplying the area under the graph of the gravitational field against distance by its mass.

The unit for gravitational field is Newtons per kilogram. The unit for the area under a graph of gravitational field against distance is (Newtons per kilogram)  $\times$  metre, hence Newton metre per kilogram or simply Joule per kilogram. The change in energy can be obtained from this area by multiplying by the mass of the object.

This method was also used in Chapter 2 on page 57 with the gravitational field close to the Earth's surface where the field strength is usually constant.

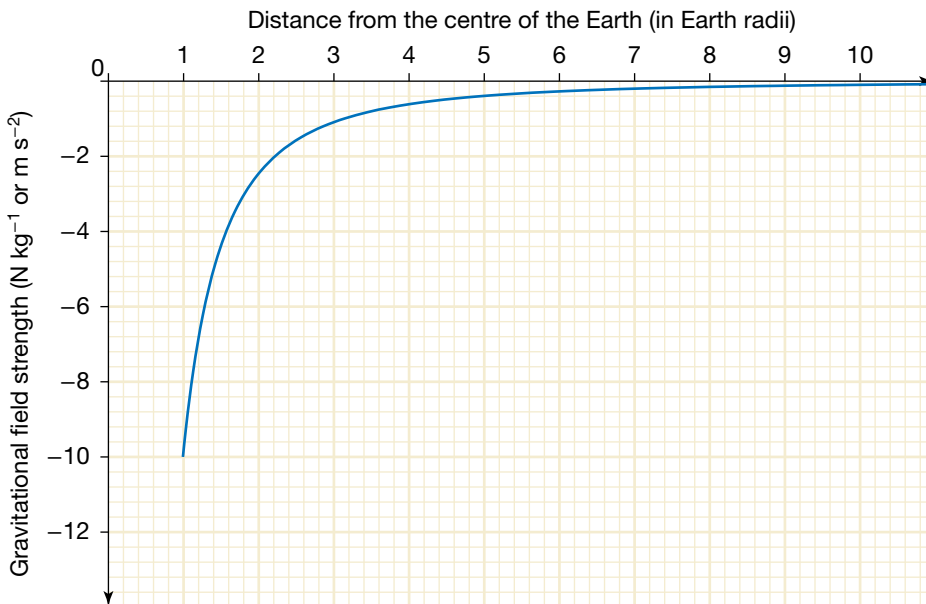

Graph of the strength of the Earth's gravitational field

### Revision question 4.7

If a rock of mass 1 kg was thrown upwards from the Earth's surface with sufficient kinetic energy to escape the Earth's gravitational field, the amount of kinetic energy required would be the area under the graph out to infinity. Using a distance of 10 Earth radii as an approximation for infinity, show that the required initial speed is about  $11 \text{ km s}^{-1}$ .

#### study on

Unit 3 **Satellites and gravitational force**

AOS 1

Topic 1 Concept summary and practice questions

Concept 3

#### study on

Unit 3 **Satellite equations of motion**

AOS 1

Topic 1 Concept summary and practice questions

Concept 4

#### study on

Unit 3

AOS 1

Topic 1 **Do more**  
How the speed and period changes with the radius of a satellite's orbit

Concept 4

## Astronauts and satellites in orbit

As we saw earlier, Newton used his law of Universal Gravitation to show that Kepler's Third Law,  $\frac{R^3}{T^2} = \frac{GM}{4\pi^2}$ , applies to all satellites going around the same central mass. In the context of the Earth, this means that  $\frac{R^3}{T^2}$  is the same for every single artificial satellite, regardless of the orientation of its orbit, as well as the Moon itself. Because we know the period and the radius of the Moon's orbit, we can use the method of ratios to calculate the characteristics of any other satellite:

$$\frac{R_M^3}{T_M^2} = \frac{R_{\text{sat}}^3}{T_{\text{sat}}^2}$$
$$\text{or } \left(\frac{R_M}{R_{\text{sat}}}\right)^3 = \left(\frac{T_M}{T_{\text{sat}}}\right)^2$$

The benefit of this method is that because you are working with ratios, you don't need to use metres and seconds for your data. Earth radii and days can be used, making for simpler calculations.

The orbit of the Moon is slightly elliptical, but the average radius of the Moon's orbit is about 384 000 km or about 60 Earth radii.

The period of the Moon in relation to the stars is called the sidereal period and has been measured at 27.321 582 days (or approximately  $2.36 \times 10^6$  seconds). For our purposes we can use 27.3 days. The period of the Moon in relation to the Sun, that is the time between full moons, is 29.5 days; this is longer than the sidereal period because in that time the Earth has moved further around the Sun.

## Geostationary satellites

Artificial satellites are used for communication and exploration. Some transmit telephone and television signals around the world, some photograph cloud patterns to help weather forecasters, some are fitted with scientific equipment that enables them to collect data about X-ray sources in outer space, whereas others spy on our neighbours! The motion of an artificial satellite depends on what it is designed to do. Those satellites that are required to rotate so that they stay constantly above one place on Earth's surface are called **geostationary** satellites and they are said to be in geostationary orbit. In order to stay in position, a geostationary satellite must have the same period as the place it is above. Therefore, geostationary satellites have a period of 24 hours or 1 day.

A satellite in **geostationary** orbit is stationary relative to a point directly below it on Earth's surface. A geostationary orbit has the same period as the rotation of Earth.

### Sample problem 4.5

What is the radius of the orbit of a geostationary satellite as a multiple of the Earth's radius and also in metres?



**Solution:**  $R_M = 60 \times R_E$ ,  $T_M = 27.3$  days,  $T_{\text{sat}} = 1$  day,  $R_{\text{sat}} = ?$

Rearranging  $\left(\frac{R_M}{R_{\text{sat}}}\right)^3 = \left(\frac{T_M}{T_{\text{sat}}}\right)^2$  to find  $R_{\text{sat}}$ :

$$\begin{aligned} R_{\text{sat}}^3 &= \left(\frac{T_{\text{sat}}}{T_M}\right)^2 \times R_M^3 \\ &= \left(\frac{1}{27.3}\right)^2 \times (60 R_E)^3 \\ &= 289.8 R_E^3 \\ R_{\text{sat}} &= 6.62 R_E \end{aligned}$$

In metres,

$$\begin{aligned} R_{\text{sat}} &= 6.62 \times 6.38 \times 10^6 \text{ m} \\ &= 4.22 \times 10^7 \text{ m} \end{aligned}$$

### Revision question 4.8

- Use a small coin to draw a circle in the middle of a blank page to represent the equator of the Earth.
- Using the answer from sample problem 4.5, put a dot on the page where you estimate a geostationary satellite would be.
- Draw two lines from the dot to the circle representing the Earth, to touch the circle at a tangent. The part of the circle facing the satellite between these two lines represents how much of the Earth's surface could receive signals from the satellite.
- Use your diagram to determine the minimum number of geostationary satellites required to cover all of the Earth's equator.
- Which parts of the Earth could not receive signals from any of these geostationary satellites?

### Revision question 4.9

Global Positioning System (GPS) satellites are used for navigation. The Navstar 66 satellite, launched in 2011, has an orbital radius of about 20 100 km. What is the period of its orbit expressed in days?

### AS A MATTER OF FACT

Why are geostationary satellites always above the equator? Why isn't there a geostationary satellite directly above central Australia?

Newton showed that the motion of a large object can be analysed as if all of its mass was concentrated at a single point, called its centre of mass. For a symmetrical object such as the Earth, the centre of mass is located at its geometric centre. Thus, all satellites around Earth are in orbit about the centre of the Earth.

If a satellite was to be directly above central Australia for 24 hours each day, the centre of its orbit would be at the centre of the matching circle of latitude, some distance away from the centre of the Earth.

If instead a satellite was to be only momentarily directly above central Australia, given the centre of its orbit is the centre of the Earth, the orbit would take it into the sky above the northern hemisphere for half the time.

This is why geostationary communication satellites orbit around the equator. A satellite dish has to be angled at the latitude of that point on the Earth to point towards one of these satellites.

**study on**

Unit 3

**Normal reaction forces in uniform orbits**

AOS 1

Topic 1

Concept summary and practice questions

Concept 6

**'Floating' in a spacecraft**

An astronaut inside the International Space Station

The appearance of an astronaut floating around inside a spacecraft suggests that there is no force acting on them, leading some people to mistakenly think that there is no gravity in space. In fact, both the astronaut and the spacecraft are in a circular orbit about the Earth.

However, you also know that if an object is moving in a curved path, changing its direction, there must be an acceleration. If the path is circular the acceleration is directed towards the centre of that path.

The astronaut and the space craft are in the same gravitational field. They are at the same distance from the centre of the Earth. They are travelling at the same speed, taking the same time to orbit the earth. Therefore, their centripetal accelerations provided by the gravitational field are the same.

For the spacecraft:

$$\frac{GM_E m_s}{R^2} = m_s \times \frac{4\pi^2 R}{T^2}$$

$$\frac{GM_E}{R^2} = \frac{4\pi^2 R}{T^2}$$

For the astronaut:

$$\frac{GM_E m_a}{R^2} = m_a \times \frac{4\pi^2 R}{T^2}$$

$$\frac{GM_E}{R^2} = \frac{4\pi^2 R}{T^2}$$

There is no need for a normal reaction force by the spacecraft on the astronaut to explain the astronaut's motion. The astronaut inside the spacecraft circles the Earth as if the spacecraft was not there. Indeed, if the astronaut is outside the spacecraft doing a space walk, the astronaut's speed and acceleration around the Earth will be unchanged as they 'float' beside the spacecraft. Once back inside, their speed and acceleration are still unchanged, and this time they are 'floating' inside the spacecraft.

If the astronaut steps onto a set of bathroom scales, they will give a reading of zero. As shown in the second photo opposite, an astronaut running on a treadmill needs stretched springs attached to his waist to pull him down to the treadmill.

This astronaut is floating inside the International Space Station. Both the astronaut and the station are in orbit around the Earth.



The cloth-covered stretched springs are pulling the astronaut down so he can exercise on the treadmill.



# Chapter review

## Summary

- The gravitational field strength  $g$  at a distance  $r$  from a body of mass  $M$  is given by the formula  $g = \frac{GM}{R^2}$  where  $G$  is the gravitational constant. The force of gravity  $F$  on an object of mass  $m$  at a distance  $r$  from the same body is therefore given by  $F = \frac{GMm}{R^2}$ . This equation is referred to as Newton's Law of Universal Gravitation.
- For a given planetary or satellite system,  $\frac{R^3}{T^2}$  is constant. The value of the constant is equal to  $\frac{GM}{4\pi^2}$  where  $M$  is the mass of the central body.
- Gravitational attraction can be explained using a field model.
- The field model enables the gravitational field around a point mass to be described in terms of its direction and shape, and also its strength.
- The field model also enables descriptions of the changes in potential energy of an object moving in the gravitational field of a point mass.
- Changes in potential energy can be calculated from the area under a force–distance graph and from the area under a field–distance graph when multiplied by mass.
- Satellites in orbit and their occupants (who are also in orbit) experience no reaction force.

## Questions

In answering the questions on the following pages, assume, where relevant, that the magnitude of the gravitational field at Earth's surface is  $9.8 \text{ N kg}^{-1}$ . Additional data required for questions relating to bodies in the solar system can be found in table 4.1 on page 110.

### Modelling the motion of satellites

1. A gravitational field strength detector is released into the atmosphere and reports back a reading of  $9.70 \text{ N kg}^{-1}$ .
  - (a) If the detector has a mass of 10 kg, what is the force of gravity acting on it?
  - (b) If the detector is to remain stationary at this height, what upwards force must be exerted on the detector?
  - (c) How far is the detector from the centre of Earth?
2. Use the information provided in table 4.1 on page 110 to calculate (i) the gravitational field strength and (ii) the weight of a 70 kg person at the surface of the following bodies of the solar system:
 

(a) Earth	(c) Venus
(b) Mars	(d) Pluto.
3. A space probe orbits a distance of  $5.0 \times 10^5 \text{ m}$  from the centre of an undiscovered planet. It experiences a gravitational field strength of  $4.3 \text{ N kg}^{-1}$ . What is the mass of the planet?
4. Calculate the force of attraction between Earth and the Sun.
5. If the Earth expanded to twice its radius without any change in its mass, what would happen to your weight?
6. By how much would your reading on bathroom scales change with the Moon on the opposite side of the Earth to you, compared with being above you?
7. Determine the value of the ratio  $\frac{F_{\text{on Moon by Sun}}}{F_{\text{on Moon by Earth}}}$ .  
Assume the Moon is the same distance from the Sun as the Earth is.
8. How many Earth radii from the centre of the Earth must an object be for the gravitational force by the Earth on the object to equal the gravitational force that would be exerted by the Moon on the object if the object was on the Moon's surface?
9. A space station orbits at a height of 355 km above Earth and completes one orbit every 92 min.
  - (a) What is the centripetal acceleration of the space station?
  - (b) What gravitational field strength does the space station experience?
  - (c) Your answers to (a) and (b) above should be the same. (i) Explain why. (ii) Explain any discrepancy in your answers.
  - (d) If the mass of the space station is 1200 tonnes, what is its weight?
  - (e) The mass of an astronaut and the special spacesuit he wears when outside the space station is 270 kg. If he is a distance of 10 m from the centre of mass of the space station, what is the force of attraction between the astronaut and the space station?
10. What is the centripetal acceleration of a person standing on Earth's equator due to Earth's rotation about its axis? (Radius of Earth is  $6.38 \times 10^6 \text{ m}$ .) Would the centripetal acceleration be greater or less for a person standing in Victoria? Justify your answer.
11. In the future, it is predicted that space stations may rotate to simulate the gravitational field of Earth and therefore make life more normal for the occupants. Draw a diagram of such a space station. Include on your diagram:

- the axis of rotation
- the distance of the occupants from the axis
- arrows indicating which direction the occupants would consider as 'down'.

(Remember to consider the frame of reference of the occupants!) Make an estimate of the period of rotation your space station would need to simulate Earth's gravitational field.

12. Neutron stars are thought to rotate at about 1 revolution every second. What is the minimum mass for the neutron star so that a mass on the star's surface is in the same situation as a satellite in orbit, that is, the strength of the gravitational field equals the centripetal acceleration at the surface?
13. The Sun orbits the centre of our galaxy, the Milky Way, at a distance of  $2.2 \times 10^{20}$  m from the centre with a period of  $2.5 \times 10^8$  years. The mass of all the stars inside the Sun's orbit can be considered as being concentrated at the centre of the galaxy. The mass of the Sun is  $2.0 \times 10^{30}$  kg. If all the stars have the same mass as the Sun, how many stars are in the Milky Way?
14. The asteroid 243 Ida was discovered in 1884. The Galileo spacecraft, on its way to Jupiter, visited the asteroid in 1993. Search online for images of the flyby. The asteroid was the first to be found to have a natural satellite, that is, its own moon, now called Dactyl. Dactyl orbits Ida at a radius of 100 km and with a period of 27 hours. What is the mass of the asteroid?

### Motion of the planets

15. What force holds the solar system together? Explain how this results in the planets moving in roughly circular orbits.
16. Venus and Saturn both orbit the Sun. Using only information about the Sun and the periods of the two planets, calculate the value of the ratio:

$$\frac{\text{distance of Saturn from the Sun}}{\text{distance of Venus from the Sun}}$$

17. A spacecraft leaves Earth to travel to the Moon. How far from the centre of the Earth is the spacecraft when it experiences a net force of zero? Use the data in table 4.1 to determine where that point is, and draw a scale diagram to show its location.
18. A satellite is in a circular orbit around the Earth with a radius equal to half of the radius of the Moon's orbit. What is the satellite's period expressed as a fraction of the Moon's period about the Earth?

### Satellites of the Earth

19. A geostationary satellite remains above the same position on Earth's surface. Once in orbit, the only force acting on the satellite is that of gravity towards the centre of Earth. Why doesn't the satellite fall straight back down to Earth?
20. A new geostationary satellite is to be launched. At what height above the centre of Earth must the satellite orbit?
21. Can a geostationary satellite remain above Melbourne? Why or why not?
22. Explain why the area under a gravitational force–distance graph gives the energy needed to launch a satellite, but the area under a gravitational field strength–distance graph gives the energy *per kilogram* needed to launch a satellite.
23. A space shuttle, orbiting Earth once every 93 mins at a height of 400 km above the surface, deploys a new 800 kg satellite that is to orbit a further 200 km away from Earth.
  - (a) Use the following graph to estimate the work needed to deploy the satellite from the shuttle.
  - (b) Use the mass and radius of Earth to assist you in determining the period of the new satellite.
  - (c) Show how the period of the new satellite can be determined without knowledge of the mass of Earth.
  - (d) If the new satellite was redesigned so that its mass was halved, how would your answers to (a) and (b) change?

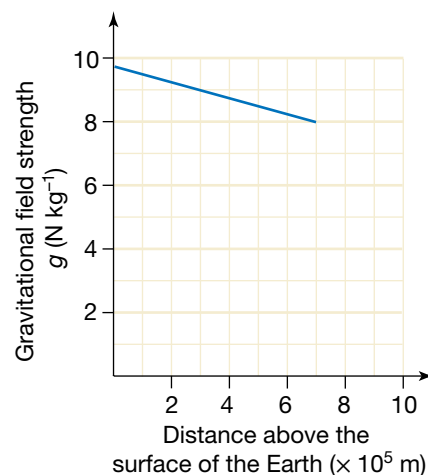

24. A disabled satellite of mass 2400 kg is in orbit around Earth at a height of 2000 km above sea level. It falls to a height of 800 km before its built-in rocket system can be activated to stop the fall continuing.

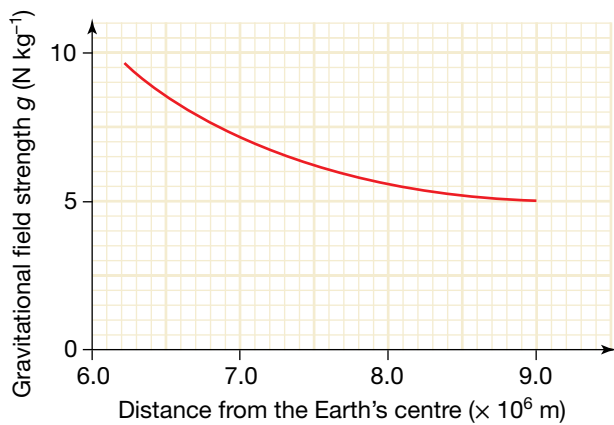

- (a) Calculate the gravitational force on the satellite while it is in its initial orbit.

- (b) Calculate the loss of gravitational potential energy of the satellite during its fall.  
 (c) If the speed of the satellite during its initial orbit is  $6900 \text{ m s}^{-1}$ , what is its speed when the rocket system is activated?

- 25.** In a space shuttle that is in orbit around Earth at an altitude of 360 km, what is the magnitude of:  
 (a) the gravitational field strength  
 (b) the reaction force by the shuttle on a 70 kg astronaut  
 (c) the gravitational force by the Earth on this astronaut?
- 26.** Why does the gravitational force do no work on a satellite in orbit?

**REMEMBER**

Before beginning this chapter, you should be able to:

- recognise that charged objects can experience forces of attraction and of repulsion
- apply the concepts of charge ( $Q$ ), current ( $I$ ), voltage ( $V$ ) and energy ( $U$ ) to electrical situations.

**KEY IDEAS**

After completing this chapter, you should be able to:

- describe electricity using a field model
- apply Coulomb's Law to the force between point charges

- describe the electric field around a point charge in terms of its direction and shape
- calculate the strength of the electric field at a point a distance,  $r$ , from a point charge
- describe potential energy changes of an object moving in the electric field of a point charge
- analyse the acceleration and potential energy changes of a charged particle in an uniform electric field.

The concept of the electric field allows us to make use of electricity to provide power and light. It also explains many physical phenomena.



## The long road to Coulomb's Law

You will probably have experienced a small electric shock when you touched a metal rail after walking across carpet. This phenomenon has been observed for thousands of years. Objects such as glass, gemstones and amber (petrified tree resin) can become 'electrified' by friction, when they are rubbed with materials such as animal fur and fabrics, producing a little spark. The Ancient Greek word for amber is *elektron*.

Investigators tried to explain the various manifestations of electricity, but an understanding of the phenomenon was elusive. Both attraction and repulsion were observed, but initially repulsion was considered less important. In 1551 Girolamo Cardano realised that this electrical attraction was different from magnetic attraction. In 1600 William Gilbert, the physician to Elizabeth I, found that other substances such as glass and wax could be 'electrified', but he concluded that metals could not. In 1729 Stephen Gray discovered that electric charge could pass through materials such as the human body and metals. He concluded that some objects are conductors and others insulators. In 1734 Charles du Fay showed that Gilbert was wrong about metals: they could be charged as long as the metal was in a handle of glass. However, du Fay thought there were two fluids, to explain the two types of charge, whereas Benjamin Franklin in 1746 suggested there was only one fluid. Objects with an excess of this fluid were designated positively charged, while negatively charged objects were deficient in the fluid.

Experiments continued, not only to identify what electricity was, but also to determine how strong the electric force was and what affected its strength.

In 1766 Franklin tried an experiment involving a hollow metal sphere with a small hole. He charged up the sphere and then lowered a small cork carrying an electric charge inside the sphere. Nothing happened to it — it was not pushed around, no matter where he placed the test charge. He wrote about this to his friend Joseph Priestley in England. Priestley was aware of Newton's Law of Universal Gravitation, which is an inverse square law ( $F \propto \frac{1}{r^2}$ ). He also knew that Newton had proved mathematically that because of the inverse square law, no net gravitational force exists inside a hollow sphere. That is, at every point inside the sphere, the gravitational force from the mass on one side is balanced by the force from the mass on the other side.

Priestley confirmed Franklin's results and realised that this was strong evidence that the inverse square law applied to electricity. In 1767 he published his finding that electric force was an inverse square law. Unfortunately, his paper went unnoticed by other scientists of his time.

If the force between two charges was an inverse square law, that is,  $F \propto \frac{1}{r^n}$  where  $n = 2$ , could the value of  $n$  be experimentally confirmed?

In 1769 John Robison investigated how the force between charges changed with separation. He determined the value of the power,  $n$ , to be 2.06, very close to 2. In the 1770s Henry Cavendish measured the value as between 1.96 and 2.04, but he never published his results.

In 1788 and 1789 Charles-Augustin de Coulomb published a series of 8 papers on different aspects of his electrical experiments, showing that the electric force satisfied the inverse square law.

**TABLE 5.1** The results of some of Coulomb's experiments

Observed force	Distance	
	Observed	Calculated from the inverse square law
36 units	36 units	36 units
144 units	18 units	18 units
576 units	8.5 units	9 units



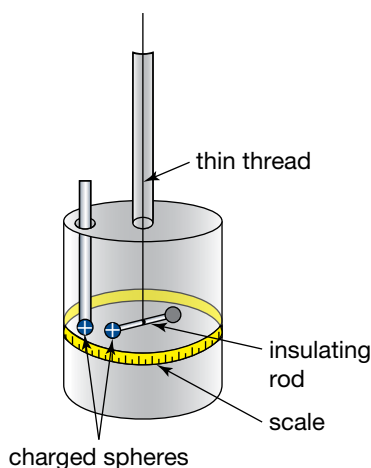

Coulomb's torsion balance

### study on

Unit 3

**Electric force**

AOS 1

Concept summary  
and practice  
questions

Topic 2

Concept 1

Quantity

Charge

Symbol

$Q$

Unit

Coulomb, C

Example

$Q = 5.0 \text{ C}$

### eBook plus

#### Interactivity

Doing the twist  
int-6608

These results are no better than the earlier ones, so why was Coulomb's Law named after him?

Coulomb's papers were excellent examples of scientific writing. They were well organised and thorough. He described his apparatus in detail, and he discussed possible sources of error in his measurements. He also used two different methods to determine the value of  $n$ , obtaining the same result with each.

To investigate the force between two charges, Coulomb designed a torsion balance. His torsion balance had a long silk thread hanging vertically with a horizontal rod attached at the end. On one end of the rod was a small metal-coated sphere. On the other end was a sphere of identical mass to keep the rod level. The metal sphere was given a quantity of charge and a second metal sphere, charged with the same type of charge, was lowered to be in line with the first sphere. The electrical repulsion caused the silk thread to twist slightly. The angle of twist or deflection of the rod was a measure of the strength of the repulsive force.

Coulomb was able to measure the force to an accuracy of less than a millionth of a Newton.

*Coulomb's Law: The force between two charges at rest is directly proportional to the product of the magnitudes of the charges and inversely proportional to the square of the distance between them.*

$$F \propto \frac{q_1 q_2}{r^2}$$

This expression has no equals sign; it is not an equation or formula. Coulomb was able to measure the force and separation very accurately, but charge was such a new concept that there were no units to measure it. Coulomb was only able to show that halving the size of each charge reduced the size of the force by a quarter.

It was not until the unit for current, the ampere, was defined and precisely measured that a unit for charge could be defined and calculated using the relationship charge = current  $\times$  time ( $Q = I \times t$ ). This unit was called the coulomb after Charles-Augustin de Coulomb. One coulomb of charge equals the amount of charge that is transferred by one ampere of current in one second.

A coulomb of charge is a large quantity of charge. For example, the amount of charge transferred when fur is rubbed against a glass rod is a few millionths of a coulomb. In a typical lightning strike, about 20 coulombs of charge is transferred, whereas in the lifetime of an AA battery, about 5000 coulombs passes through the battery.

When the electron was discovered, its charge was determined as  $1.602 \times 10^{-19}$  coulombs, which means that the total charge of  $6.241 \times 10^{18}$  electrons would equal one coulomb.

Once a unit to measure charge was available, the above relationship for the force between charges could be written as an equation with a proportionality constant,  $k$ :

$$F = \frac{kq_1 q_2}{r^2}$$

where  $k$  is a constant with a value of  $8.988 \times 10^9 \text{ N m}^2 \text{ C}^{-2}$ . (In fact, it only has this value if there is a vacuum between the charges. Air has a similar value, but if the charges are immersed in any other substance, the force is reduced.)

For ease of calculation and remembering, the value of  $k$  is usually approximated to  $9.0 \times 10^9 \text{ N m}^2 \text{ C}^{-2}$ . This constant has no special name, unlike the constant in Newton's Law of Universal Gravitation. It goes by various names, such as 'the electric force constant' and 'Coulomb's constant'.

## Electric fields

Attraction and repulsion between charges occurs without the need for contact. There is 'action at a distance'. To explain such interactions, Michael Faraday (1791–1867) proposed the concept of a 'field'. In the case of an electric charge, there was an electric field in the space around the charge such that if a second charge was placed in that space, it would experience an electrical force. The electric field at that point interacts directly with this second charge to produce a force.

If the first charge is represented by  $Q$  and the second charge is a small test charge,  $q$ , then the force is given by  $F = \frac{kQq}{r^2}$ . The strength of the electric field,  $E$ , is defined by the force on the small test charge divided by the size of the test charge, or force per unit charge, and the unit for electric field is Newtons per coulomb or  $\text{N C}^{-1}$ :

$$E = \frac{F}{q}$$

$$E = \frac{\left(\frac{kQq}{r^2}\right)}{q}$$

$$E = \frac{kQ}{r^2}$$

This is a similar situation to the expressions for gravitational field.

**TABLE 5.2** Comparison between expressions for electric and gravitational fields

Force and field between masses	Force and field between charges
$F_g = \frac{Gm_1m_2}{r^2}$	$F = \frac{kq_1q_2}{r^2}$
$F_g = mg$	$F = qE$
$g = \frac{GM}{r^2}$	$E = \frac{kQ}{r^2}$

However, electrical interactions are different from gravitational interactions in that electric charges can attract and repel. There are two types of charge, positive and negative, with like charges repelling each other and unlike charges attracting.

## Drawing an electric field

When we draw a gravitational field, the field lines indicate the direction in which a mass would move. But for an electric field, because there are two types of charge, a convention is needed so that we can correctly interpret field diagrams. The convention is that the direction of the field is the direction in which a positive charge would move. This is shown in the following diagrams.

**study on**

Unit 3

**Field around a point mass and point charge**

AOS 1

Topic 4

Summary screen and practice questions

Concept 1

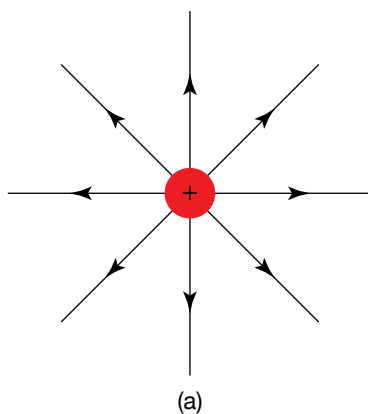

(a)

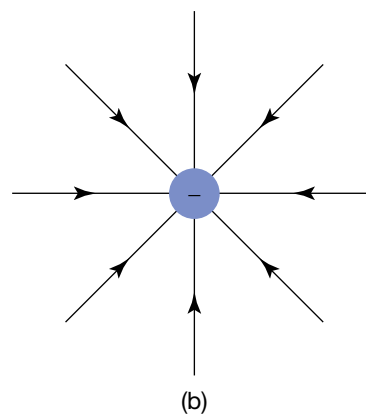

(b)

Fields around (a) a positive charge and (b) a negative charge

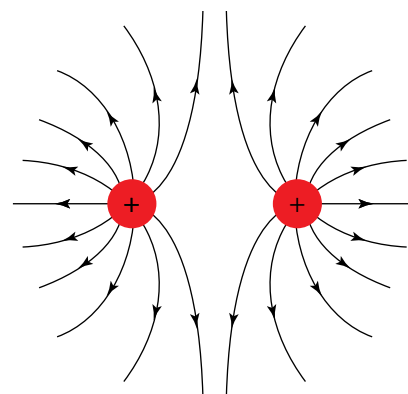
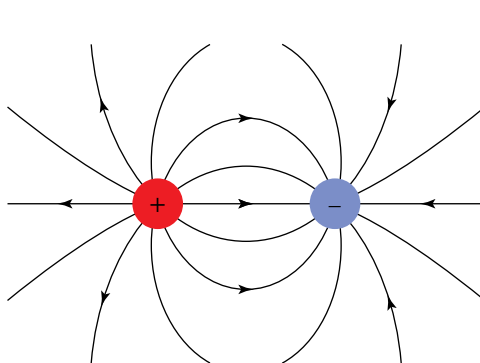

Fields around (a) a positive and negative charge of equal quantity, and (b) two positive charges of equal value. Close spacing of field lines indicates a strong field. Diverging lines indicate the field is weaker.

**Revision question 5.1**

Draw the electrical fields around the following configurations.

- (a) Two separated negative charges  
 (b) Two positive charges and two negative charges at the corners of a square with like charges diagonally opposite each other

**Calculating the value of an electric field**The strength of an electric field can be determined from the equation  $E = \frac{kQ}{r^2}$ .**Sample problem 5.1**What is the magnitude and direction of the electric field at a point 30 cm left of a point charge of  $+2.0 \times 10^{-5}$  C?**Solution:** Using  $E = \frac{kQ}{r^2}$ ,

$$E = \frac{9.0 \times 10^9 \text{ Nm}^2 \text{ C}^{-2} \times 2.0 \times 10^{-5} \text{ C}}{(30 \times 10^{-2} \text{ m})^2}$$

$$= 2.0 \times 10^6 \text{ NC}^{-1}$$

Because the point charge is positive, the direction of the electric field is to the left.

partial negative charge

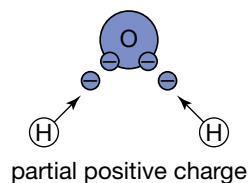

A water molecule ( $\text{H}_2\text{O}$ ) displays polarity because the shared electrons are attracted more strongly to the oxygen atom than to the hydrogen atoms.

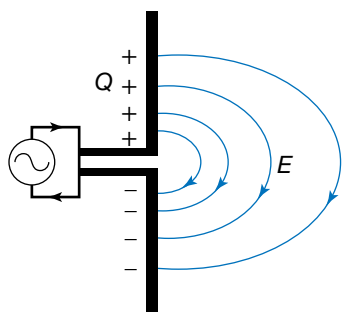

Partial circuit diagram of an antenna

## Revision question 5.2

What is the magnitude and direction of the electric field at a point 50 cm right of a point charge of  $-3.0 \times 10^{-6} \text{ C}$ ?

## Dipole fields

When a positive charge and a negative charge are separated by a short distance, the electric field around them is called a dipole field. This concept is more relevant to magnetic fields, where the ends of a bar magnet have different polarities (north and south). However, electric dipoles do occur in nature.

Electric dipoles mainly occur with the shared electrons in the bonds between atoms in molecules. For example in a molecule of water,  $\text{H}_2\text{O}$ , the oxygen atom more strongly attracts the shared electrons than do each of the hydrogen atoms. This makes the oxygen end of the molecule more negatively charged and the hydrogen end more positively charged. Because of this, the water molecule is called a polar molecule. It is this polarity that makes water so good at dissolving substances.

An antenna can be described as a varying electric dipole. To produce a radio or a TV signal, electrons are accelerated up and down the antenna. At one moment the top may be negative and the bottom positive, then a moment later the reverse is the case.

## AS A MATTER OF FACT

### The structure of DNA and electrical attraction

A DNA molecule is a long chain molecule built from four small molecules: adenine (A), cytosine (C), guanine (G) and thymine (T). These are arranged along the DNA molecule according to a code called the genetic code. Different sequences of A, C, G and T code for different amino acids, which are combined one after the other to produce different protein molecules. Two DNA molecules wrap around each other in a spiral to produce a double-helix chromosome.

The two DNA molecules in the helix are held together by electrical attraction between the polar ends of the four small molecules, A, C, G, and T. The chromosome is able to replicate itself because A and T can only pair up with each other, and likewise C and G can only pair up with each other. If there is an A on one strand, there must be a T immediately opposite on the other strand, and so on.

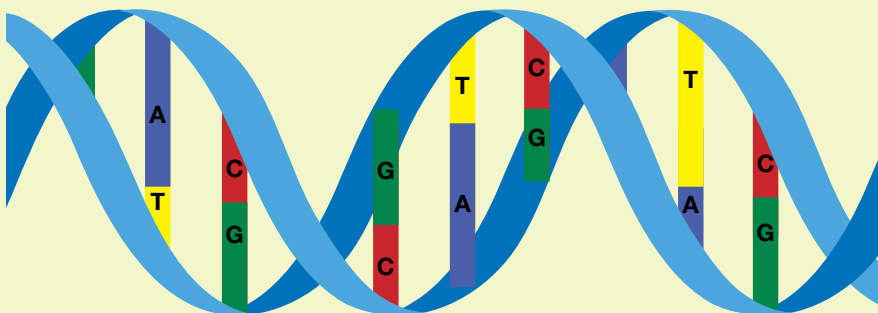

Electrical attraction in a DNA molecule

The figure below shows that one of the oxygen atoms in the thymine molecule is slightly negative, and one of the hydrogen atoms in the adenine molecule is slightly positive. Similarly, a hydrogen atom in the thymine molecule is slightly positive, and a nitrogen atom in the adenine molecule is slightly negative. These two slight electrical attractions are enough to hold these two molecules together, and the separations across these weak bonds are comparable in length.

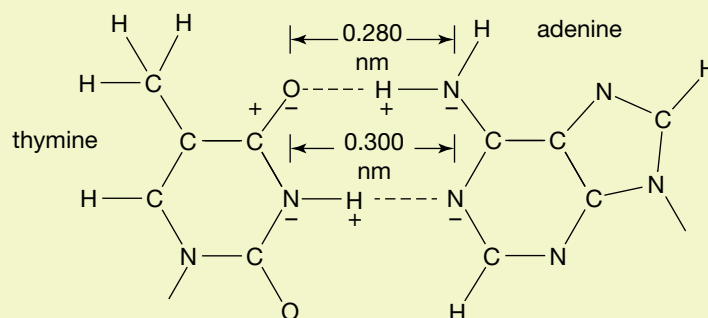

Electrical attraction between thymine and adenine molecules

Guanine and cytosine have a similar arrangement, except that there are three pairs of electrical attraction. Most importantly, the separations of the weak bonds between guanine and cytosine are comparable to each other and also to those of adenine and thymine. Without this matchup of separations, a chromosome could not hold together, nor could it form a double helix.

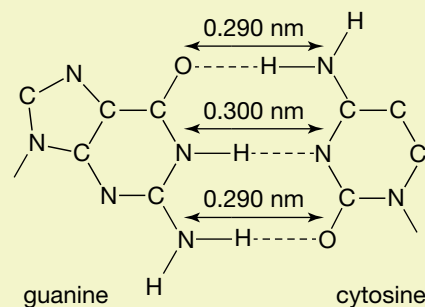

Electrical attraction between guanine and cytosine molecules

## Graphing the electric field

The direction of the electric field is the direction in which a positive test charge would move.

For a central positive charge, the direction of the electric field vector at a point P is in the same direction as the distance vector to the point P. This means the graph of the electric field with distance is above the distance axis.

For a central negative charge, the direction of the electric field vector is in the opposite direction to the radius vector, so the graph of the electric field around a negative charge will be below the distance axis.

Diagrams and field–distance graphs for the electric field around (a) a positive charge and (b) a negative charge

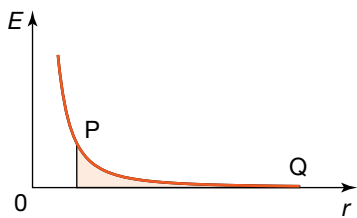
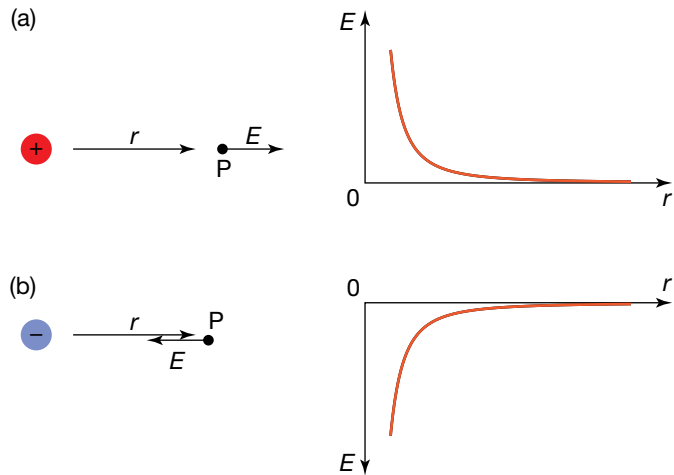

A field–distance graph for a positive charge at  $P$  near a central positive charge at  $Q$

## Changes in potential energy and kinetic energy in an electric field

A small positive charge is placed at point  $Q$ , some distance from a central positive charge. To move the charge to point  $P$ , you will need to push inwards against the repulsive electrical force. At point  $P$  the small charge will have electrical potential energy, like a compressed spring. The amount of potential energy it has will be equal to the area under the field–distance graph times its charge. If the small charge was released, all this potential energy would be converted into kinetic energy by the time the charge reached  $Q$ .

If instead a small negative charge was placed at  $Q$ , it would experience an attractive electrical force, and when the charge reached  $P$ , the shaded area would represent its gain in kinetic energy.

## Uniform electric fields

If a set of positive and negative charges were lined up in two rows facing each other, the lines of electric field in the space between the rows would be evenly spaced, that is, the value of the strength of the field would be constant. This is called a uniform electrical field.

It is also very easy to set up. Just set two metal plates a few centimetres apart, then connect one plate to the positive terminal of a battery and connect the other plate to the negative terminal of the battery. The battery will transfer electrons from one plate, making it positive, and put them on the other, making that one negative. The battery will keep on doing this until the positive plate is so positive that the battery's voltage, or the energy it gives to each coulomb of electrons, is insufficient to overcome the attraction of the positive charged plate. Similarly, the negatively charged plate will become so negative that the repulsion from this plate prevents further electrons being added.

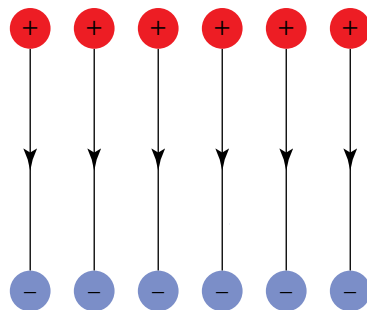

A uniform electric field

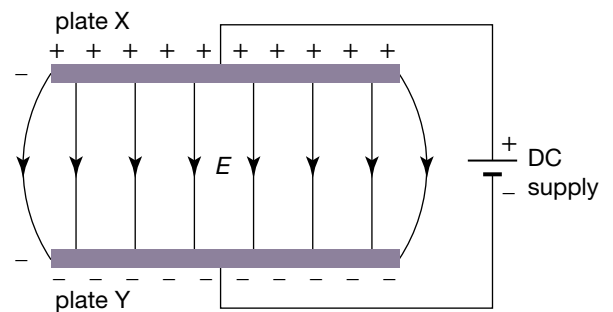

An electric field between two plates

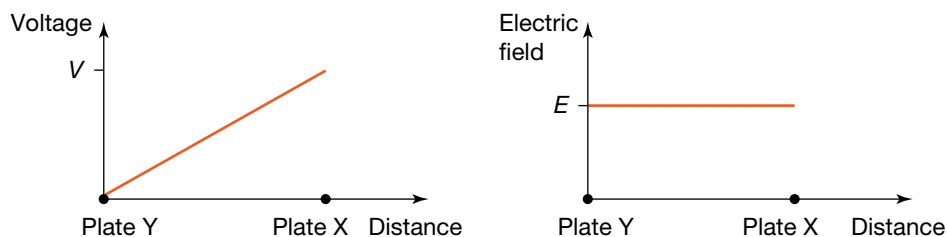

Electric field strength equals the gradient of the voltage–distance graph.

If a space contains a uniform field, that means that if a charge was placed in that space it would experience a constant electric force,  $F = Eq$ . The direction of the force on a positive charge will be in the direction of the field, and the force on a negative charge will be opposite to the field direction. Also, because the force is constant, the acceleration will be constant. As we will see later, the situation with a charged particle in the space between the plates in the figure above is similar to the vertical motion under gravity. Indeed, if a charged particle is injected with speed into the field from one side, its subsequent motion is similar to projectile motion.

### study on

Unit 3

**Electric fields**

AOS 1

Concept summary and practice questions

Topic 2

Concept 2

### study on

Unit 3

**Change in potential energy**

AOS 1

Concept summary and practice questions

Topic 2

Concept 3

### What is the strength of a uniform electric field?

In the situation of an electric field between two plates, it is not easy to apply Coulomb's Law, as there are many charges on each plate interacting with each other. An alternative approach is needed — one that uses the concept of energy.

The emf of a battery, or its voltage, is the amount of energy that the battery gives to each coulomb of charge. A battery of  $V$  volts would use up  $V$  joules of energy transferring one coulomb of electrons from the top plate through the wires to the bottom plate. Once on the negative plate, this coulomb of electrons would have  $V$  joules of electrical potential energy.

If this coulomb of electrons could be released from the negative plate, it would be accelerated by the constant force of the electric field between the plates, gaining kinetic energy like a stone falling in a gravitational field. And as in a gravitational field, the gain in kinetic energy equals the loss in electrical potential energy.

The gain in kinetic energy of one coulomb of charge =  $V$  joules.

The gain in kinetic energy for  $q$  coulombs of charge =  $qV$  joules.

This is the relationship  $W = qV$ .

$$\text{Work done on } q \text{ coulombs of charge } (W) = \frac{\text{quantity of charge } (q)}{\text{charge } (q)} \times \text{voltage drop or potential difference } (V)$$

However, work done ( $W$ ) also has a definition of motion:

$$\text{Work done } (W) = \text{force } (F) \times \text{displacement } (d)$$

$$W = Fd$$

But the force, if it is an electrical force, is given by  $F = qE$ , so  $W = qE \times d$ , where  $d$  in this instance is the separation of the plates.

Equating the two expressions for work done,

$$qE \times d = q \times V.$$

Cancelling the charge,  $q$ , gives

$$E = \frac{V}{d}.$$

This provides an alternative unit for electric field of volts per metre or  $\text{V m}^{-1}$ . So, like gravitational field strength, electric field strength has two equivalent units: either newtons per coulomb or volts per metre. Using volts per metre makes it very easy to determine the strength of a uniform electric field.

### Sample problem 5.2

What is the strength of the electric field between two plates 5.0 cm apart connected to a 100 V DC supply?

**Solution:**  $V = 100 \text{ V}$ ,  $d = 5.0 \text{ cm} = 5.0 \times 10^{-2} \text{ m}$ ,  $E = ?$

$$\begin{aligned} E &= \frac{V}{d} \\ &= \frac{100 \text{ V}}{5.0 \times 10^{-2} \text{ m}} \\ &= 2000 \text{ V m}^{-1} \end{aligned}$$

### Revision question 5.3

- Calculate the strength of the electric field between a storm cloud 1.5 km above ground and the ground itself if the voltage drop or potential difference is 30 000 000 V. Assume a uniform field.
- How would the strength of the electric field change if the storm cloud was higher?

In developing the expression for the strength of a uniform electric field, the relationship  $W = Vq$  was used. The implication of  $W = Vq$  is that the energy gained by a charge in moving across the gap between the plates only depends on the voltage drop or the potential difference across them. It does not depend on the separation of the plates. This does not seem right, because if the plates are further apart, the electric field is weaker by  $E = \frac{V}{d}$ , so the force and the acceleration will be less.

The explanation is that although the force may be less when the plates are further apart, the force acts on the charge over a greater distance. If the separation is doubled, the field strength and therefore the force is halved, but it acts over twice the distance.

Work done = force  $\times$  displacement

$$W = Fd$$

Using the definition of an electric field,  $F = qE$ , this becomes

$$W = qE \times d.$$

Using the alternative formula for electric field strength,  $E = \frac{V}{d}$ , this becomes

$$W = q \times \left( \frac{V}{d} \right) \times d.$$

Simplifying,

$$W = qV.$$

### An electric field as a particle accelerator

An electric field can be used to increase the speed and kinetic energy of charged particles. This is the case in all of the devices in the following table.

#### study on

Unit 3

Work done by a uniform field

AOS 1

Concept summary and practice questions

Topic 2

Concept 4



**TABLE 5.3** Devices that use electric fields to accelerate charged particles

Device	Operation	Purpose
Mass spectrometer	Accelerate positive ions of different mass, which then enter a uniform magnetic field and curve around to hit a screen in different spots	To measure the abundance of different elements and isotopes in a sample
Electron microscope	Accelerate electrons, which then pass through electric and magnetic lenses to produce an image	To use an electron beam to examine very small objects
Synchrotron	Accelerate electrons close to the speed of light, then feed them into a storage ring	To produce intense and very narrow beams of mainly X-rays to examine the fine structure of substances such as proteins
Large Hadron Collider	Accelerate protons or lead ions close to the speed of light, then let them collide	To test the predictions of theories of particle physics, e.g. the existence of the Higgs boson

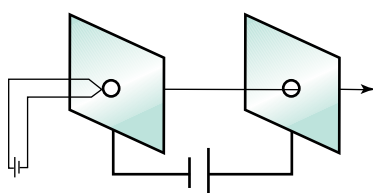

The electrons on the hot filament are attracted across to the positive plate and pass through the hole that is in line with the beam.

The first part of all of these devices is an electron gun, a device that is designed to produce electrons and then give them an initial acceleration.

The diagram shows two metal plates with a small hole cut in the middle of each plate. The plates have been connected to a DC power supply. In the hole of the negative plate is a filament of wire, like the filament in an incandescent light globe, connected to a low voltage. When the current flows in this circuit, the filament glows red hot. The electrons are, in a sense, 'boiling at the surface' of the filament. The electric field can easily pull the electrons off the surface of the filament.

The hole in the positive plate is in a direct line with the filament, so as the electrons are accelerated across the space between the plates, they go straight through the hole to the next part of the machine. This design is called an electron gun. It produces the electrons that generate the picture in a television tube, and it also produces the electrons for a synchrotron.

### Sample problem 5.3

An electron is accelerated from one plate to another. The voltage drop between the plates is 100 V.

- How much energy does the electron gain as it moves from the negative plate to the positive plate?
- How fast will the electron be travelling when it hits the positive plate, if it left the negative plate with zero velocity?

Use mass of electron =  $9.1 \times 10^{-31}$  kg, charge on electron =  $1.6 \times 10^{-19}$  C.

**Solution:**

$$\begin{aligned} \text{(a) } W &= Vq \\ &= 100 \text{ V} \times 1.6 \times 10^{-19} \text{ C} \\ &= 1.6 \times 10^{-17} \text{ J} \end{aligned}$$

Energy gained is  $1.6 \times 10^{-17}$  J.

- Energy is gained as kinetic energy.

$$\begin{aligned} E_k &= \frac{1}{2}mv^2 \\ 1.6 \times 10^{-17} \text{ J} &= \frac{1}{2} \times 9.1 \times 10^{-31} \text{ kg} \times v^2 \\ v^2 &= \frac{2 \times 1.6 \times 10^{-17} \text{ J}}{9.1 \times 10^{-31} \text{ kg}} \\ v &= 5.9 \times 10^6 \text{ m s}^{-1} \end{aligned}$$

The speed of the electron is  $5.9 \times 10^6 \text{ m s}^{-1}$  or  $5900 \text{ km s}^{-1}$ , which is about 2% of the speed of light.

## Revision question 5.4

Repeat sample problem 5.3 but with a voltage drop of 1000 V.

Beyond an accelerating voltage of 1000 V, special relativity comes into play (as discussed in chapter 3). In relativistic situations, as the speed comes closer to the speed of light, the method shown above for determining the speed of the electron increasingly gives the wrong answer.

## Linking the concepts together

In this chapter, the four concepts of force, field, energy and potential have been used to explain electrical interactions and to calculate the values of various physical quantities. The significance of these concepts and their relationships is not only that the same concepts can be used for other fields, but that the relationships between the concepts are the same in different types of fields.

The relationships are best illustrated in a diagram. For example, consider a uniform electric field. If you start with the potential,  $V$ , in the bottom right corner, each of the other three quantities can be determined by the mathematical operations beside each arrow.

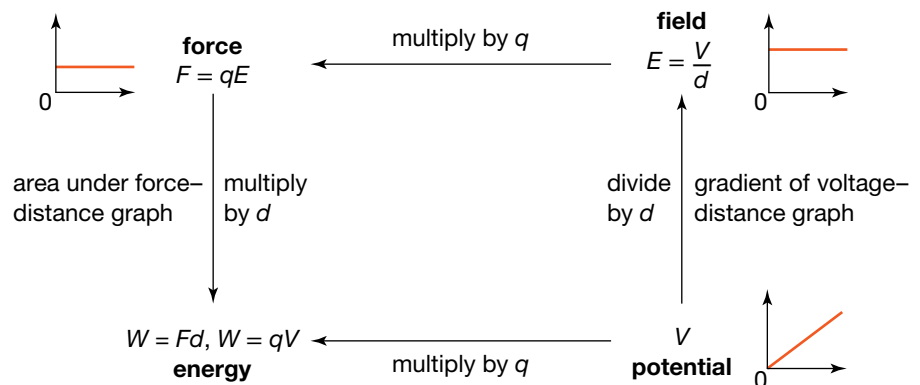

The relationships between force, field strength, energy and potential in a uniform electric field

Note that the descriptions for the down arrow on the left are the opposite mathematical operation to the descriptions for the up arrow on the right. 'Divide' is the opposite of 'multiply', and 'gradient' is the opposite of 'area under the graph'.

The same analysis can be applied to the electric field around a point charge. This time, start with force and Coulomb's Law.

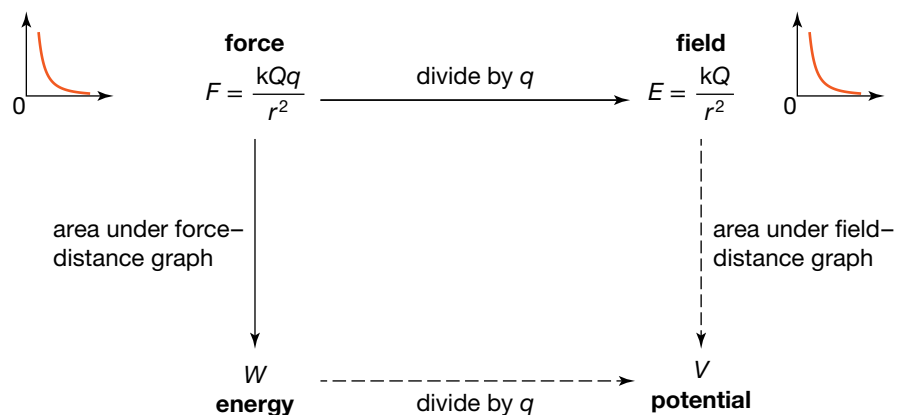

The relationships between force, field strength, energy and potential in an electric field around a point charge

The course covered by this textbook considers energy in non-uniform electric fields, such as the field around a point charge, in only a qualitative manner. Further study of electric fields will cover expressions for electrical potential energy and electric potential near a point charge.

These two diagrams for a uniform field and a non-uniform field also have their parallels in gravitation. The only change is to replace charge,  $q$  with mass,  $m$ .

### Revision question 5.5

As a revision exercise for gravitation, as well as to check on your understanding of the above diagrams, complete the following diagram for a uniform gravitational field, starting with  $g$ , the gravitational field strength.

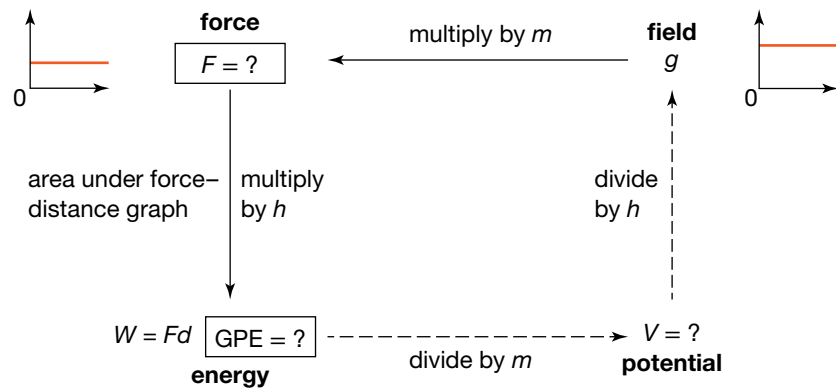

The relationships between force, field strength, energy and potential in a uniform gravitational field

*Note:* The concept of gravitational potential is not of much use for calculations in a uniform gravitational field. This is because, unlike electrical technology, gravitation does not have a 'gravitational battery' that can deliver energy in joules per kilogram in the way a battery can supply joules per coulomb.



# Chapter review

## Summary

- Electric interactions between charges can be described with a field model.
- The electric field strength,  $E$ , at a distance  $r$  from an object with charge  $Q$  is given by the formula  $E = \frac{kQ}{r^2}$ , where  $k$  is the electric force constant. The electric force on an object with charge  $q$  is given by  $F = qE$  or  $F = \frac{kQq}{r^2}$ . This equation is referred to as Coulomb's Law.
- The electric field lines around a point charge describe the direction and shape of the field.
- The electric force between two charges can be attractive or repulsive, depending on whether the two charges are unlike or alike respectively. When two charges are held close together, there is potential energy stored in the electric field, and this potential energy is converted to kinetic energy when the charges are free to move.
- A uniform electric field exists between two metal plates connected to a DC supply. The strength of the electric field,  $E$ , is given by the voltage drop or potential difference across the plates,  $V$ , over the plate separation,  $d$ :  $E = \frac{V}{d}$ . This uniform field produces a constant force on a charge and thus a constant acceleration.
- The energy transferred to a charge  $q$  in moving from one plate to the other is given by  $W = Vq$ .

## Questions

### Electric force between point charges

1. What is the experimental evidence for there being two types of charge?
2. A and B are metal spheres  $x$  metres apart. Each has a charge of  $+q$  coulombs. The force they exert on each other is  $5.0 \times 10^{-4}$  newtons. Determine the magnitude of the force in each of the following situations. (Consider the situations separately.)
  - (a) The separation of A and B is increased to  $2x$  metres.
  - (b) A charge of  $+2q$  coulombs is added to B. Are the forces on A by B and on B by A still equal in magnitude?
  - (c) A charge of  $-3q$  coulomb is added to A.
  - (d) The distance is halved and the charges are changed to  $+0.5q$  on A and  $4q$  on B.
3. Find the force of repulsion between two point charges with charges of  $5.0$  microcoulombs ( $\mu\text{C}$ ) and  $7.0$  microcoulombs ( $\mu\text{C}$ ) if they are  $20$  cm apart.
4. If the force between two charges was  $400$  mN, how far apart would they need to be moved for the force to reduce by one-eighth?
5. How far apart would two charges, each of  $1.0$  coulomb, need to be to each experience an electric force of  $10$  N?
6. Two charged spheres are  $5.0$  cm apart, with one holding twice the amount of charge of the other. If the force between is  $1.5 \times 10^{-4}$  newtons, how much charge does each sphere have?
7. Two small spheres are placed with their centres  $20$  cm apart. The charges on each are  $+4.0 \times 10^{-8}$  C and  $+9.0 \times 10^{-8}$  C. Where between the two spheres would a test charge experience zero net force?
8. Coulomb's Law is very similar to Newton's Law of Universal Gravitation. How do these two laws differ? Compare electric charge and gravitational mass.
9. How many electrons would need to be removed from a coin to give it a charge of  $+10$   $\mu\text{C}$ ?
10. The radius of a hydrogen atom is  $5.3 \times 10^{-11}$  m. What is the strength of the electric force between the nucleus and the electron?
11. The nucleus of an iron atom has  $26$  protons, and the innermost electron is  $1.0 \times 10^{-12}$  m away from the nucleus. What is the strength of the electric force between the nucleus and the electron?
12. The nucleus of a uranium atom has  $92$  protons, and the innermost electron is about  $5.0 \times 10^{-13}$  m away from the nucleus. What is the strength of the electric force between the nucleus and the electron?
13. A proton is made up of two 'up' quarks of charge  $+\frac{2e}{3}$  and one 'down' quark of charge  $-\frac{1e}{3}$ . The diameter of a proton is about  $8.8 \times 10^{-16}$  m. Using the diameter as the maximum value for the separation of the two 'up' quarks, calculate the size of the electrical repulsion force between them.
14. What equal positive charge would the Earth and the Moon need to have for the electrical repulsion to balance the gravitational attraction? Why don't you need to know separation of the two objects?
15. What is the charge in coulombs of  $10$  kg of electrons?
16. One example of alpha decay is uranium-238 decaying to thorium-234. The thorium nucleus has  $90$  protons and the alpha particle has two protons.

At a moment just after the ejection of the alpha particle, their separation is about  $9.0 \times 10^{-15}$  m. What is the size of the electrical repulsion force between them, and what is the acceleration of the alpha particle at this point?

17. What is the size of the electric force between a positive sodium ion ( $\text{Na}^+$ ) and a negative chloride ion ( $\text{Cl}^-$ ) in a NaCl crystal if their spacing is  $2.82 \times 10^{-10}$  m?
18. An electric force of 1.5 N acts upwards on a charge of  $+3.0 \mu\text{C}$ . What is the strength and direction of the electric field?
19. An electric force of 3.0 N acts downwards on a charge of  $-1.5 \mu\text{C}$ . What is the strength and direction of the electric field?
20. A proton is suspended so that it is stationary in an electric field. Using the value of  $g = 10 \text{ m s}^{-2}$ , determine the strength of the electric field.
21. Use the statement 'the electric force exerted by a charged object A on a charged object B is proportional to the charge on B' and Newton's Third Law to show that the electric force between the two charges is proportional to the **product** of the charges.

### Electric fields of point charges

22. Electric field lines can never cross. Why?
23. If a charged particle is free to move, will it move along an electric field line?
24. Two charged objects, A and B, are held a short distance apart. Which object is the source of the electric field that acts on B?
25. One of the units for gravitational field is that of acceleration. Is that also true for electric field? If not, why not?
26. Sketch the electric field around two positive charges, A and B, where the charge on A is twice that on B.
27. Sketch the electric field around a positively charged straight plastic rod. Assume the charge is distributed evenly. Sketch the electric field as if the rod had a curve in it. If the plastic rod was bent into a closed circle, what would be the strength of the electric field in the middle?
28. A negative test charge is placed at a point in an electric field. It experiences a force in an easterly direction. What is the direction of the electric field at that point?
29. Two small spheres, A and B, are placed with their centres 10 cm apart. P is 2.5 cm from A. What is the direction of the electric field at P in the following situations?
  - (a) A and B have the same positive charge.
  - (b) A has a positive charge, B has a negative charge and the magnitudes are the same.
30. Determine the strength of the electric field 30 cm from a charge of  $120 \mu\text{C}$ .
31. What is the strength of the electric field 1.0 mm from a proton?

### Uniform electric fields

32. Two metal plates, X and Y, are set up 10 cm apart. The X plate is connected to the positive terminal of a 60 V battery and the Y plate is connected to the negative terminal. A small positively charged sphere is suspended midway between the plates and it experiences a force of  $4.0 \times 10^{-3}$  newtons.
  - (a) What would be the size of the force on the sphere if it was placed 7.5 cm from plate X?
  - (b) The sphere is placed back in the middle and the plates are moved apart to a separation of 15 cm. What is the size of the force now?
  - (c) The plates are returned to a separation of 10 cm but the battery is changed. The force is now  $6.0 \times 10^{-3}$  newtons. What is the voltage of the new battery?
33. Electrons from a hot filament are emitted into the space between two parallel plates and are accelerated across the space between them.

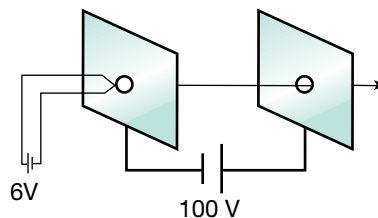

- (a) Which battery supplies the field to accelerate the electrons?
- (b) How much energy would be gained by an electron in crossing the space between the plates?
- (c) How would your answer to (b) change if the plate separation was halved?
- (d) How would your answer to (b) change if the terminals of the 6 V battery were reversed?
- (e) How would your answer to (b) change if the terminals of the 100 V battery were reversed?
- (f) How would the size of the electric field between the plates, and thus the electric force on the electron, change if the plate separation was halved?
- (g) Explain how your answers to (c) and (f) are connected.
34. (a) Calculate the acceleration of an electron in a uniform electric field of strength  $1.0 \times 10^6 \text{ N C}^{-1}$ .

- (b) Starting from rest, how long would it take for the speed of the electron to reach 10% of the speed of light? (Ignore relativistic effects.)
- (c) What distance would the electron travel in that time?
- (d) If the answer to (c) was the actual spacing of the plates producing the electric field, what was the voltage drop or potential difference across the plates?

**35.** In an inkjet printer, small drops of ink are given a controlled charge and fired between two charged plates. The electric field deflects each drop and thus controls where the drop lands on the page.

Let  $m$  = the mass of the drop,  $q$  = the charge of the drop,  $v$  = the speed of the drop,  $l$  = the horizontal

length of the plate crossed by the drop, and  $E$  = electric field strength.

- (a) Develop an expression for the deflection of the drop. *Hint:* This is like a projectile motion question.
- (b) With the values  $m = 1.0 \times 10^{-10}$  kg,  $v = 20$  m s<sup>-1</sup>,  $l = 1.0$  cm and  $E = 1.2 \times 10^6$  N C<sup>-1</sup>, calculate the charge required on the drop to produce a deflection of 1.2 mm.

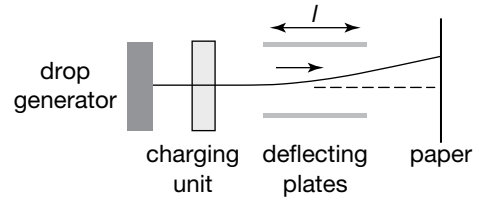

# 6 Magnetic fields

## REMEMBER

Before beginning this chapter, you should be able to:

- recall that magnets can both attract and repel
- recall that magnets line up with Earth's magnetic field
- recall that the ends of a magnet are labelled a 'north-seeking end' and a 'south-seeking end', or a north end and south end for short
- determine the direction of conventional current in a DC circuit from the polarity of the battery.

## KEY IDEAS

After completing this chapter, you should be able to:

- describe magnetism using a field model
- recall that magnetic fields can be represented by magnetic field lines, which start at a north end and go to a south end, indicating the direction a magnetic compass would point
- use the concept of a magnetic field to explain magnetic phenomena produced by bar magnets and current in wires, loops and solenoids
- describe the attraction and repulsion that can occur between magnets and current-carrying conductors
- realise that magnetic fields can be constant or changing in time, and can be uniform or varying in strength and direction
- use the right-hand-grip rule to determine the direction of the magnetic field associated with a current
- recall the unit in which magnetic fields are measured
- determine the size and direction of the force on a current in a wire due to a magnetic field
- explain the structure and operation of a simple DC motor, including the role of the commutator
- describe the path of a charged particle in a magnetic field
- determine the size and direction of the force on a charge moving in a magnetic field
- determine the radius of the path of an electron in a magnetic field
- describe the acceleration of charged particles in particle accelerators as the particles move through electric and magnetic fields.



This strong magnet sitting on top of a glass shelf creates a magnetic field that is able to attract small pieces of metal.

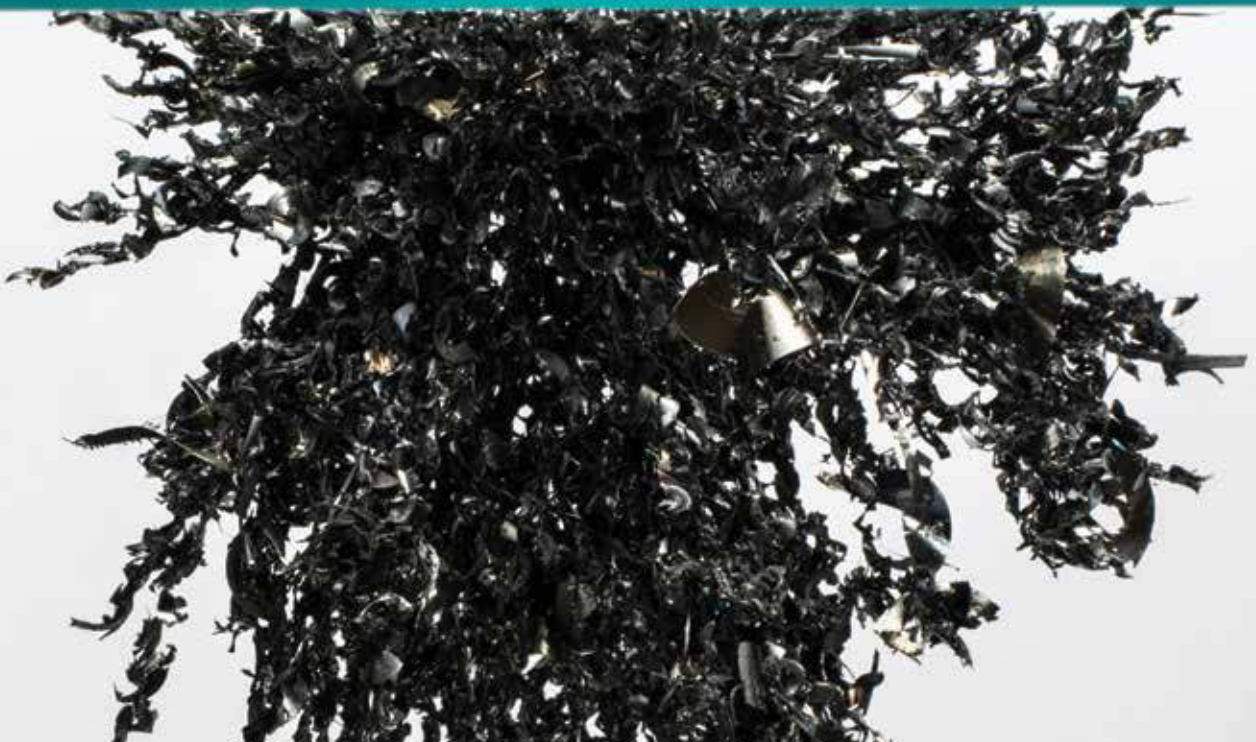

## Early ideas about magnetism

**Induction** is the process of producing magnetic properties in one object due to the presence of another object with magnetic properties.

Magnetism has been known of since the beginning of recorded history. The ancient Athenians (600 BC) observed that a stone could attract pieces of iron. They called this stone 'magnet' because it was found in an area that was then called Magnesia (now in Turkey). They noticed that the pieces of iron attracted to this stone could also then attract other pieces. The magnet had 'magnetised' the iron it was in contact with. This process is called **induction**.

### AS A MATTER OF FACT

The stone called 'magnet' is an iron oxide called magnetite. It has the chemical formula  $\text{Fe}_3\text{O}_4$ . It is black, metallic and quite hard. The stone has also been called a lodestone, which comes from 'leading stone'. This refers to the fact that a magnet, if free to move, orients itself along a north-south line.

In trying to explain their observations of magnetism, the Greeks and Romans concentrated on the fact that magnets attract iron.

Lucretius in his book, *De Rerum Natura* (On the Nature of Things), said the following:

At this point, I will set out to explain what law of nature causes iron to be attracted by that stone which the Greeks call from its place of origin, 'magnet', because it occurs in the territory of Magnesia. Men look upon this stone as miraculous. They are amazed to see it form a chain of little rings hanging from it. Sometimes you may see as many as five or more in pendant succession swaying in the light puffs of air; one hangs from another, clinging to it underneath, and one derives from another the cohesive force of the stone. Such is the permeative power of this force.

...

So much by way of preface... it will be easy to lay bare... the cause of the attraction of the iron. First, this stone must emit a dense stream of atoms which dispels by a process of bombardment all the air that lies between the stone and the iron. When this space is emptied and a large tract in the middle is left void, then atoms of the iron all tangled together immediately slide and tumble into the vacuum. The consequence is that the ring itself follows and so moves in with its whole mass. No other substance is so rigidly held together by the entanglement of its elemental atoms as cold iron, that stubborn and benumbing metal.

...

Summing up in a few brief words, when the textures of two substances are mutually contrary, so that the hollows in the one correspond to the projections in the other... then connection between them is most perfect. It is even possible for some things to be coupled together, as though interlinked by hooks and eyes. And such, it would seem is the linkage between iron and magnet.

While Lucretius provides a picturesque model of a magnet's attraction for iron, it does not explain later observations. From about AD 800 onwards, most cultures discovered that magnets always point in the same direction if free to spin. The magnetic compass became a necessary tool for navigation and exploration.

In ancient times, while the attraction of magnets for iron was an obvious phenomenon, the repulsion between magnets was either not observed or not considered as important as the attraction. The early ideas do not explain repulsion.

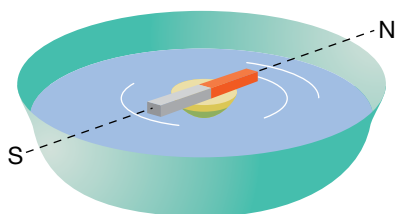

A magnet will line up with a line from north to south if it is allowed to spin freely.



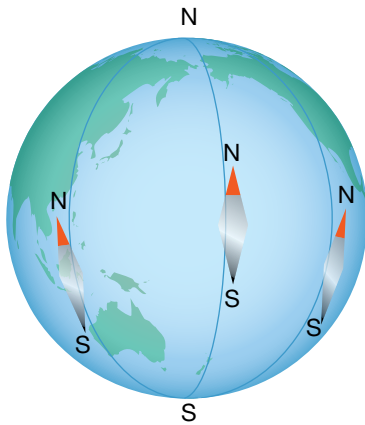

The end of the magnet marked 'S' is called the south end of the magnet because it points generally towards geographic south.

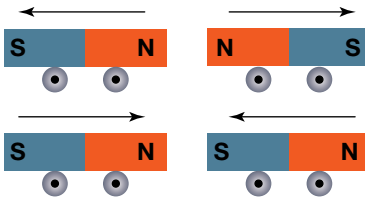

Like ends repel; unlike ends attract.

It was only much later that the attraction and the repulsion between two magnets were treated equally. This appreciation led Peter Peregrinus, a French soldier living in the thirteenth century, to propose three ideas.

1. The ends of the magnet, where the strongest attraction for iron occurred, were different from each other.
2. When the ends were brought together, the two like ends repelled each other.
3. The two unlike ends attracted each other.

The end of the magnet that pointed towards the north was called the north-seeking end, or north end for short. The other end was called the south end.

These simple ideas were forgotten during the Middle Ages. In the sixteenth century, Dr Gilbert, a physician to Queen Elizabeth I, developed the same ideas. He also found that a freely suspended magnet dipped down at an angle to the horizontal, and that this angle varied with latitude. He explained these observations by suggesting that Earth contained a magnet.

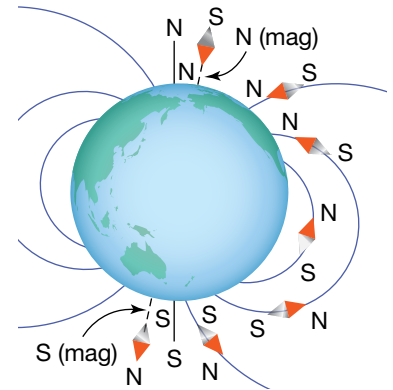

A magnet compass not only aligns itself along a line from north to south, it also dips downwards at an angle that varies with latitude. At a region near the South Geographic Pole, called the South Magnetic Pole, it actually points vertically downwards.

Today, Gilbert's idea of a solid magnet inside Earth is rejected because Earth's crust does not contain sufficient iron for the measured strength of Earth's magnetism. Also, much of Earth's core is molten liquid. A satisfactory explanation is still being sought of the origin of Earth's magnetism.

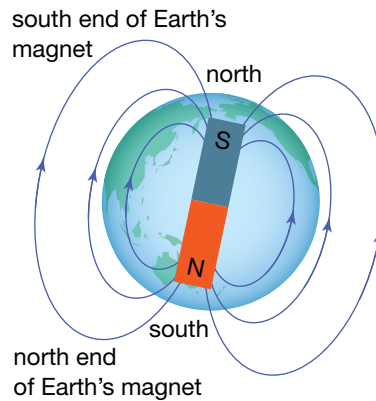

A compass needle is lined up by Earth's magnet. The south-seeking end of the needle points towards geographic south. But because unlike ends attract, this end of Earth's magnet must be a magnetic north end.

Although Gilbert's work was a major breakthrough, his concept of how magnets attracted the iron was very similar to that of Lucretius:

Magnetic force is something animate, it imitates a soul, nay, it surpasses the human soul. It sends forth its energy without error... quick, definite, constant, directive, imperant, harmonious. The magnet emits an effluvium which reaches out to the attracted body as a clapping arm and draws it to itself.

A **magnetic field** describes the property of the space around a magnet that causes an object in that space to experience a force due only to the presence of the magnet.

## Magnetic fields

It was only when Michael Faraday (1791–1867) suggested the concept of a **magnetic field** that a useful model appeared. The magnetic field was described as a property of the space around a magnet, so that if a piece of iron was in that space it would experience a force. The lines typically drawn around a magnet represent the direction of this field, and their closeness, its strength. The lines are imaginary; they are just an aid in visualising a very abstract, but useful concept. A picture (or diagram) of iron filings around a magnet is an effective representation of a magnetic field.

There are rules for drawing field lines. These are listed below.

- Each field line is a continuous loop that leaves the north end of the magnet, enters at the south end and passes through the magnet back to the north end.
- Field lines do not intersect.
- The direction of the magnetic field at a point is along the tangent to the field line.
- The closeness of the lines represents the strength of the magnetic field.

Magnets can be designed to produce fields of different shapes. A horseshoe magnet with the ends adjacent produces a strong and even field between the ends. A circular magnet with a north end in the middle produces a radial field that points outward all the way around. This design is used in loudspeakers.

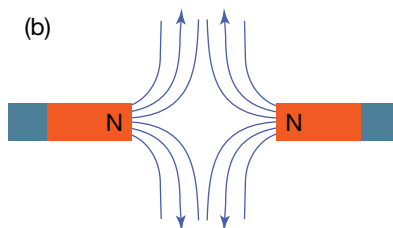
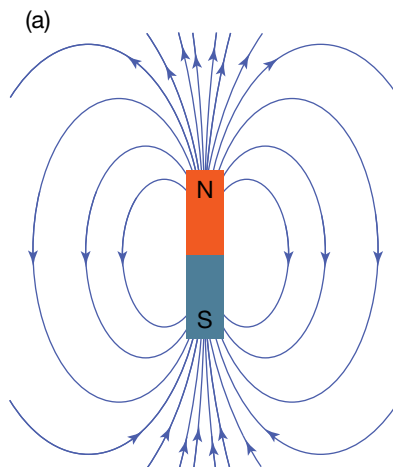

(a) A magnetic field can be represented by the direction and closeness of field lines on a page. (b) Closer lines represent increased strength.

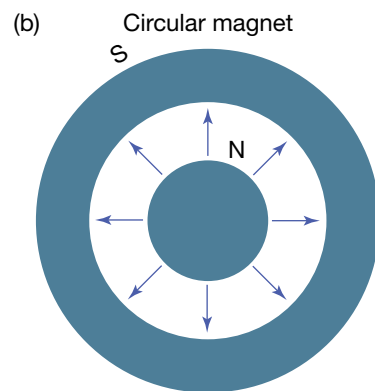
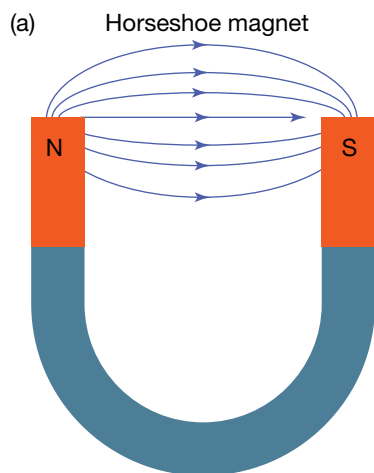

Differently shaped magnetic fields can be created by arranging the north and south ends of the magnet, as shown by (a) a horseshoe magnet and (b) a circular magnet.

Some magnets have stronger fields than others. The strength of a magnetic field is measured in tesla. The strength of Earth's magnetic field at its surface is quite small, about  $10^{-4}$  tesla or 0.1 millitesla (0.1 mT). The strength of a typical school magnet is about 0.1 T. A fridge magnet is about 30 mT. The strongest permanent magnetic fields typically produced have field strengths of about 1.0 T.

### eBookplus

#### Digital doc

Investigation 6.1  
Magnetic compass  
doc-18538

### study on

Unit 3 **Fields of bar magnets**

AOS 1 Summary screen

Topic 3 and practice questions

Concept 1

### AS A MATTER OF FACT

Pigeons and honey bees have been found to have small fragments of magnetite in their bodies. Earth's magnetic field exerts a force on these creatures. It is possible the pigeon or honey bee is able to detect the force and use it to navigate across Earth's surface.

**Weblink**

Magnetic field around a wire applet

**study on**

Unit 3

**Magnetic field of a current**

AOS 1

Summary screen

Topic 3

and practice

Concept 2

questions

# Magnetic effect of a current

Hans Christian Oersted, like many others at the time (1820), thought there was a connection between electricity and magnetism. He placed a wire carrying a current over a magnetic compass and saw that the needle deflected. He then placed the wire under the compass and the needle deflected in the opposite direction. Log in to [www.jacplus.com.au](http://www.jacplus.com.au) to locate the Magnetic field around a wire applet weblink for this chapter.

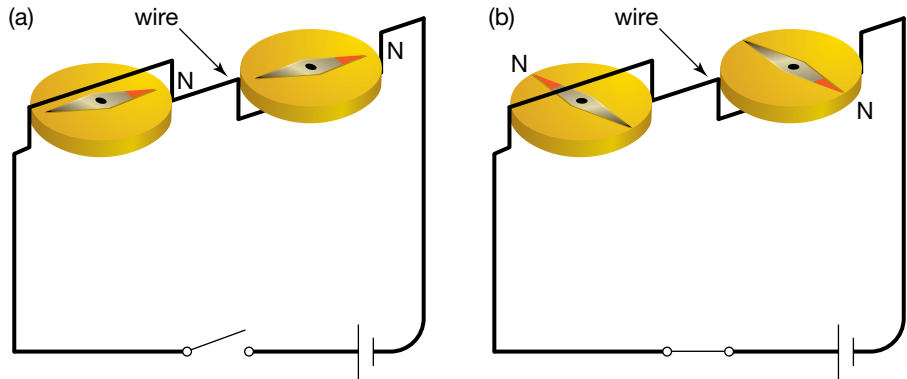

(a) Switch open in circuit, and (b) switch closed in circuit. To achieve maximum deflection, the wire should be placed in line with the magnetic needle before the current is turned on.

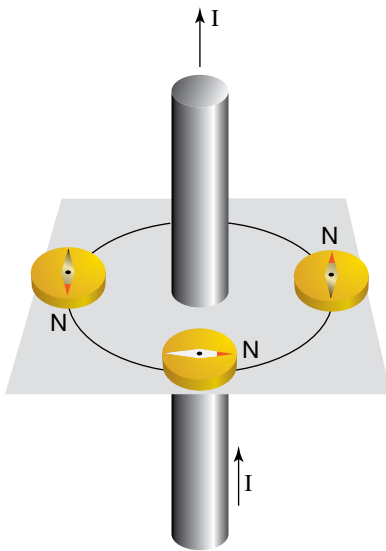

The compasses around the wire show a circular magnetic field.

Deflection of a compass needle means there is a magnetic field associated with the current, which causes the needle to line up with it. Using a compass, the field around a current in a wire can be mapped.

To represent current and its magnetic field often requires a three-dimensional view. To achieve this on a flat two-dimensional page, a convention is adopted. The symbol of a circle with a dot in the middle is used to represent a magnetic field coming out of a page. A circle with a diagonal cross is used to represent a magnetic field going *into* the page.

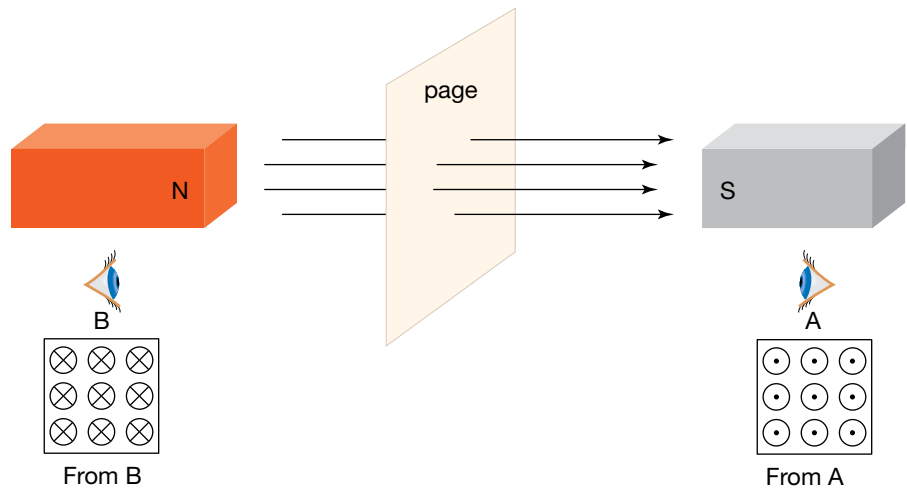

Magnetic fields going into the page (from B) and coming out of the page (from A)

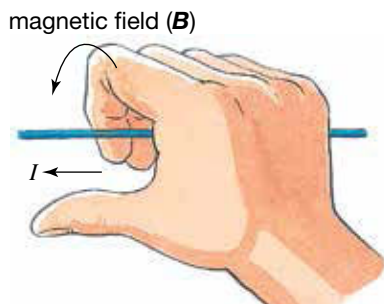

If a right hand holds the wire with the thumb pointing in the direction of the conventional current, the fingers curl around the wire in the direction of the magnetic field.

A **solenoid** is a coil of wire wound into a cylindrical shape.

Applying the right-hand-grip rule to each part of the loop reveals that at all points of the loop the magnetic field is curving in the same direction.

The symbols described on the previous page are designed to suggest in the instance on the right the point of an arrow coming towards the reader and, in the instance on the left, the feathers of the arrow going away from the reader.

## The right-hand-grip rule

If the current is reversed, the magnetic field changes to the opposite direction. A rule is therefore needed so that the direction of the field can be determined in a variety of different situations.

A convenient rule is the right-hand-grip rule. The wire carrying the current is grabbed by the right hand, but the thumb must point in the direction that conventional current flows in the wire. (Remember: conventional current flows from the positive terminal to the negative terminal.) The fingers then will wrap around the wire in the direction of the magnetic field.

Applying the right-hand-grip rule to a loop of wire shows that the magnetic field comes in on one side of the loop and out of the other side, all the way around the loop. Joining loops together results in a **solenoid**. The magnetic fields from each loop add together to produce a stronger magnetic field.

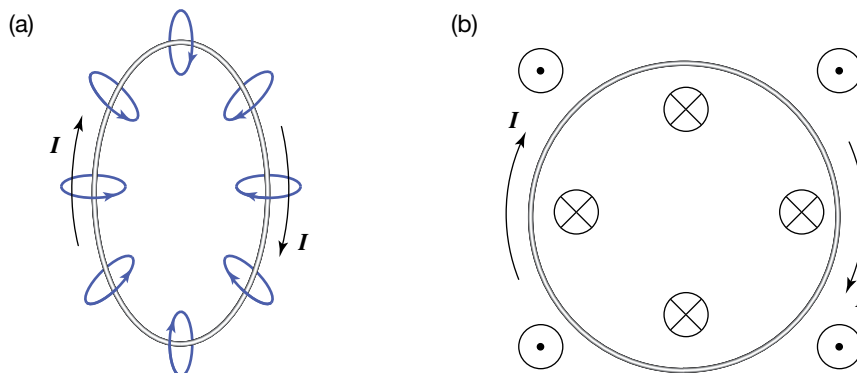

If the loops are very close together, the field lines within the coil are parallel to the axis of the coil. The field lines then emerge from one end of the solenoid, curve around and enter the other end of the solenoid, completing the path for the field lines. The shape of this field is similar to that of a bar magnet. The ends of the solenoid can be labelled north and south. The field emerges from the north end. Looking from this end along the axis, the current is seen to be travelling anticlockwise. The other end is opposite.

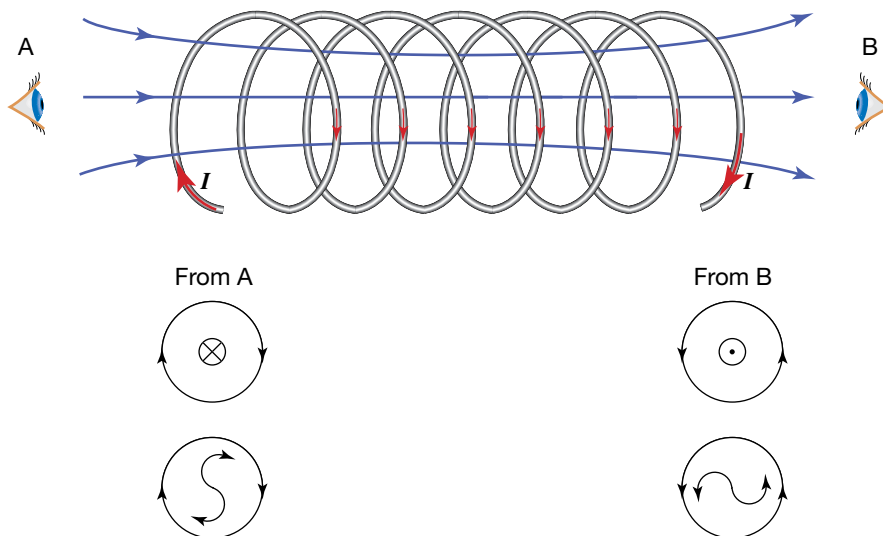

### study on

**Unit 3** **Magnetic fields of loops and solenoids**  
**AOS 1**  
**Topic 3** Summary screen and practice questions  
**Concept 3**

### study on

**Unit 3** **See more**  
**AOS 1** **Magnetic fields**  
**Topic 3**  
**Concept 3**

Using the right-hand-grip rule with a solenoid

### Revision question 6.1

Use the right-hand-grip rule to determine the direction of the magnetic field at point X in the following diagrams.

(a)

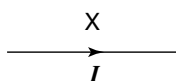

(b)

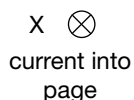

An **electromagnet** is a temporary magnet produced when a solenoid wound around an iron core carries an electric current.

In 1823 an English electrical engineer, William Sturgeon, found that when he placed an iron rod inside a solenoid, it greatly increased the strength of the magnetic field of the electric current to the point where it could support more than its own weight. Sturgeon had invented the **electromagnet**. He ultimately built a 200 g electromagnet with 18 turns of copper wire that was able to hold 4 kg of iron with current supplied by one battery.

By placing an iron core inside a solenoid, Sturgeon had made a magnet that could be turned on and off at the flick of a switch, and made stronger by increasing the current. His invention has many applications. In a wrecking yard, for example, electromagnets are used to separate metals containing iron from other metals.



Car parts being lifted by an electromagnet in a car wrecking yard

#### eBookplus

**Digital doc**  
Investigation 6.2  
Electromagnets  
doc-18539

The difficulty with using iron in an electromagnet is that when the current is turned off, the iron loses its magnetism. However, by adding carbon to the iron to produce an alloy, the magnetism is not lost when the current is turned off — a permanent magnet has been made. Stronger and more long-lasting magnets are made with different combinations of elements. The common 'alnico' magnets in schools are made from iron (54%), nickel (18%), cobalt (12%), aluminium (10%) and copper (6%).

Recent magnetic developments include the flexible fridge magnet, where microscopic particles of magnetite are mixed with a molten plastic and placed in a magnetic field while the plastic solidifies, and neodymium magnets, which contain the elements neodymium and boron in addition to iron. This produces a very high magnetic field strength.

## Differences between magnetic fields

In the section headed 'Magnetic fields' (page 148), the pictures of the different magnetic field configurations show that there are regions in the space around the magnets where the lines are close together, so the field strength is high. In regions where the lines are further apart, the field strength is low. This is in contrast to the diagrams in the section 'Magnetic effect of a current' (page 149), where the lines are evenly spaced. The latter are examples of uniform fields, whereas the former are examples of fields that are non-uniform, meaning they vary in strength and direction through the space.

### AS A MATTER OF FACT

The strength of a magnetic field 1.0 cm from a wire carrying 100 A is about 2.0 mT. The small currents in the nerves of the human body produce magnetic fields of about  $10^{-11}$  T. Electromagnets used in research have a short-term strength of about 70 T, which requires a momentary current of 15 000 A.

The magnetic field around the human heart is about  $5 \times 10^{-11}$  T, about one millionth of Earth's magnetic field. To measure fields of this size, it is necessary to use a magnetically shielded room and a very sensitive detector called a SQUID (a Superconducting QUantum Interference Device) that can measure fields down to  $10^{-14}$  T. The magnetocardiogram produced is a useful diagnostic tool.

## Explaining magnetism

The solenoid provides a model for the magnetism in a magnet and the iron rod. The shapes of the magnetic fields of a solenoid and of a magnet are identical. The magnetic field in the solenoid is produced by a current travelling in a circle, and the magnetic field is at right angles to the plane of the circle.

Electrons travel around the nucleus of an atom in circlelike paths, so each electron must produce its own magnetic field. In most atoms the paths of the electrons are randomly oriented, so their magnetic fields cancel out. However, the paths of a few electrons in an iron atom always line up. These are shielded by outer electrons, so they are not disturbed by other atoms. In this way each iron atom can act as a little magnet.

When there is a current flowing through a solenoid with an iron core, the magnetic field lines up all the atoms in the iron core so their magnetic fields all point in the same direction. This creates a very strong field. However, when the current is turned off, the motion of the atoms rapidly produces a random rearrangement due to their temperature.

In artificial magnets (e.g. fridge magnets) other elements are added to iron to hold the iron atoms in place while they are lined up by another magnetic field, so they stay lined up. This produces a permanent magnet. The crystal structure of magnetite forces its atoms to line up.

## AS A MATTER OF FACT

In a piece of iron, groups of nearby atoms line up together throughout the metal into regions called magnetic domains. When the iron is placed in a magnetic field, the domains that are already lined up with the external field increase in size as other domains shrink.

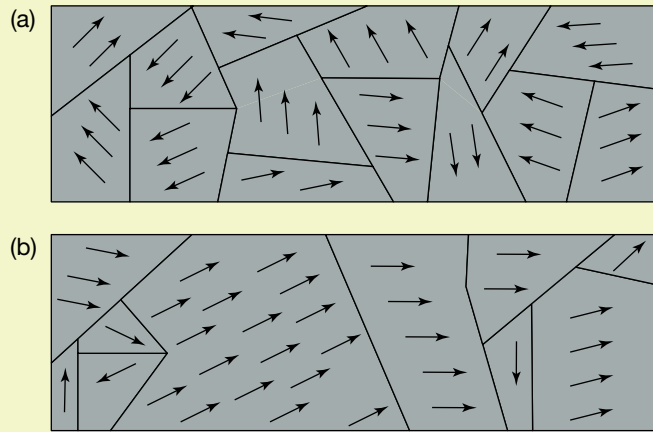

(a) The magnetic fields of adjacent iron atoms align themselves in local areas called domains. (b) Domains in a piece of iron exposed to a magnetic field, acting to the right

## Comparing gravitational, electric and magnetic fields

Gravitational, electric and magnetic fields are all properties of the space around an object, whether the object is a mass, a charge or a magnetic pole. Lines are used to show the direction of the field, that is, the direction a test object would move; the strength of the field is shown by the density of the lines. For some field diagrams, it is not possible to tell the type of field simply by looking at the diagram.

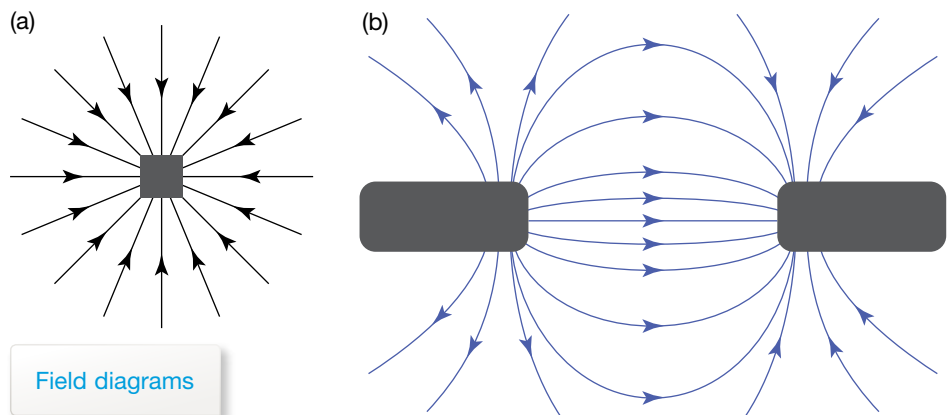

Field diagrams

For example, field diagram (a) could show either a gravitational field around a mass or an electric field around a negative point charge. It could not be a magnetic field, as even though it might look like the field near the south pole of a magnet, there would be a north pole not too far away.

## study on

Unit 3

**Magnetic force on a current**

AOS 1

Summary screen and practice questions

Topic 3

Concept 4

## eBook plus

### Weblink

Lorentz force applet

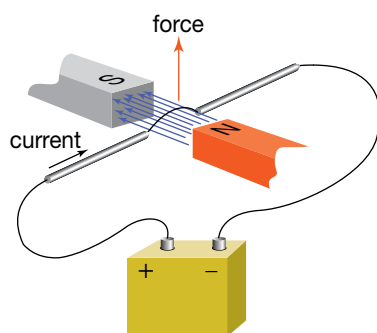

The magnetic field exerts a magnetic force on a current-carrying wire.

## eBook plus

### Digital doc

Investigation 6.3  
Measuring the strength of a magnetic field  
doc-18540

## study on

Unit 3



AOS 1

**Do more**  
Changing magnetic force

Topic 3

Concept 4

Similarly, field diagram (b) could show either an electric field around two opposite charges or a magnetic field around north and south poles. However, it could not be a gravitational field, because mass does not come in two opposite versions.

## Magnetic force on an electric current

Once the technology of electromagnets was developed, very strong magnetic fields could be achieved. This enabled the reverse of Oersted's discovery to be investigated: what is the effect of a magnetic field on a current in a wire?

In Oersted's experiment the magnetic field due to the current exerts a force on the magnetic field of the compass. So, according to Newton's Third Law of Motion, the compass exerts an equal and opposite force on the current. What is the size of this force and in what direction does it act?

Observations of the magnetic force applied to the current-carrying wire show that:

- if the strength of the magnetic field increases, there is a larger force on the wire
- if the magnetic field acts on a larger current in the wire, there is a larger force
- if the magnetic field acts on a longer wire, there is a larger force
- it is only the component of the magnetic field that is perpendicular to the current that causes the force
- if there are more wires in the magnetic field, there is a larger force.

Combined, these findings can be expressed as:

magnetic force on a current ( $F$ ) = number of wires ( $n$ )  $\times$  current in each wire ( $I$ )  $\times$  length of wire ( $l$ )  $\times$  strength of the magnetic field ( $B$ ),  
or

$$F = n \times I \times l \times B.$$

The units are expressed as:

$$1 \text{ newton} = 1 \times 1 \text{ ampere} \times 1 \text{ metre} \times 1 \text{ tesla}.$$

When the magnetic field is perpendicular to the direction of the current (and hence the length vector) in a single wire, the magnitude of the force is given by:

$$F = IlB.$$

When the magnetic field is not perpendicular to the direction of the current, it is important to remember that the force on the wire is less. In fact, if the magnetic field is parallel to the direction of the current, the force on the wire is zero. That is because the component of magnetic field perpendicular to the current is zero.

### Sample problem 6.1

If a straight wire of length 8.0 cm carries a current of 300 mA, calculate the magnitude of the force acting on it when it is in a magnetic field of strength 0.25 T if:

- the wire is at right angles to the field
- the wire is parallel with the field.

**Solution:**

- The magnetic field is perpendicular to the direction of current.

$$\begin{aligned} F &= IlB \\ &= 3.00 \times 10^{-1} \text{ A} \times 8.0 \times 10^{-2} \text{ m} \times 0.25 \text{ T} \\ &= 6.0 \times 10^{-3} \text{ N} \end{aligned}$$

- The magnetic field is parallel to the direction of current. Therefore the component of magnetic field that is perpendicular to the current is zero.

$$\begin{aligned} F &= IlB \\ &= 3.00 \times 10^{-1} \text{ A} \times 0 \text{ m} \times 0.25 \text{ T} \\ &= 0 \end{aligned}$$



### Revision question 6.2

- (a) Calculate the force on a 100 m length of wire carrying a current of 250 A when the strength of Earth's magnetic field at right angles to the wire is  $5.00 \times 10^{-5}$  T.
- (b) The force on a 10 cm wire carrying a current of 15 A when placed in a magnetic field perpendicular to  $B$  has a maximum value of 3.5 N. What is the strength of the magnetic field?

If the magnetic field is pointing to the right across the page, and the current is going down the page, the direction of the magnetic force is up, out of the page. The direction of this force will be important in applications such as meters and motors, so it is necessary to have a rule to determine the direction of the force in a variety of situations. There are two alternative hand rules commonly used. These are described below.

### Left-hand rule

The left-hand rule applies as follows:

- the index finger, pointing straight ahead, represents the magnetic field ( $B$ )
- the middle finger, at right angles to the index finger, represents the current ( $I$ )
- the thumb, upright at right angles to both fingers, represents the force ( $F$ ).

Lock the three fingers in place so they are at right angles to each other. Now rotate your hand so that the field and current line up with the directions in your problem. The thumb will now point in the direction of the force.

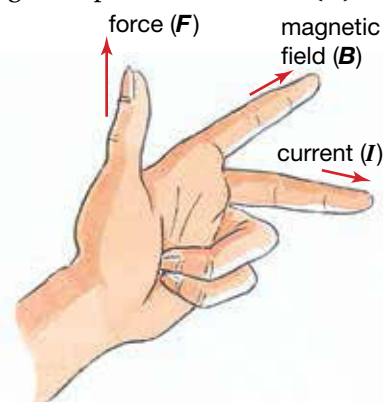

Left-hand rule for determining the direction of the magnetic force of a magnetic field on a current

### eBookplus

Digital doc  
Investigation 6.4  
Hand rules  
doc-18541

### Right-hand-slap rule

The right-hand-slap rule applies as follows:

- the fingers (out straight) represent the magnetic field ( $B$ )
- the thumb (out to the side of the hand) represents the current ( $I$ )
- the palm of the hand represents the force ( $F$ ).

Hold your hand flat with the fingers outstretched and the thumb out to the side, at right angles to your fingers. Now rotate your hand so that the field and current line up with the direction in your problem. The palm of your hand now gives the direction of the force, hence the name.

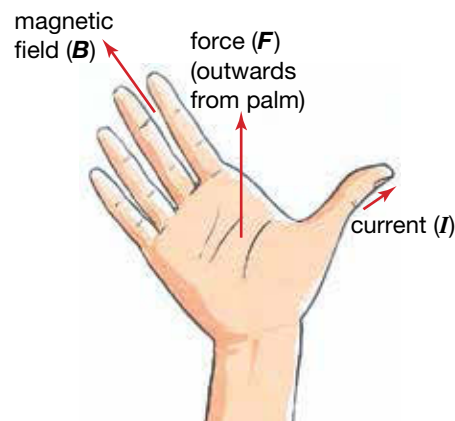

Right-hand-slap rule for determining the direction of the magnetic force of a magnetic field on a current

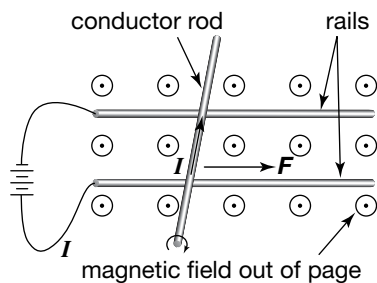

A metal conductor rod rolling along two rails

### eBook plus

#### Interactivity

Torque

int-0049

#### eLessons

Torque

eles-0025

How maglev trains work

eles-2556

**Torque** is the turning effect of a force.

### eBook plus

#### Digital doc

Investigation 6.5

Meters

doc-18542

A simplified DC motor

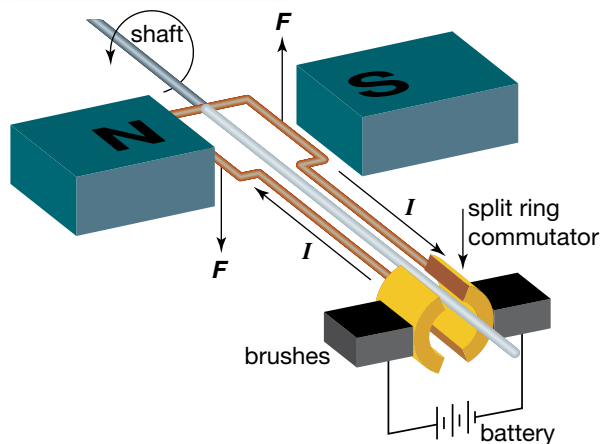

## Magnetic propulsion

When a current flows along the closest rail (the lower of the two rails in the figure at left, through the conductor rod and back to the power supply, the conductor will experience a force to the right due to the magnetic field. This force will make the conductor accelerate. If there is little friction, it can move at high speeds.

## Meters

In the electrical meter illustrated in the figure at right, the force on the wire BA is out of the page. The current travels around to D and then to C, so the force on wire DC is into the page. The two forces are the same size because the strength of the magnetic field is the same on both sides of the coil, the current through the coil is the same at all points and the lengths BA and DC are the same. However, the forces are in opposite directions. The net force is therefore zero. However, the forces do not act through the centre of the coil, so the combined forces have a turning effect. The turning effect of the forces is called a **torque**. The magnitude of the torque on a coil is the product of the force applied perpendicular to the plane of the coil and the distance between the line of action of the force and the shaft or axle.

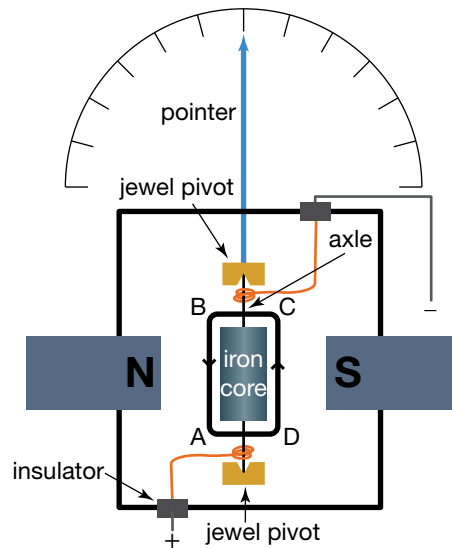

An electrical meter

If a spring is attached to the axle, the turning effect of the forces unwinds the spring until the spring pushes with an equal torque. A pointer attached to the axle measures the size of the torque, which depends on the size of the current. The larger the current through the meter, the larger the magnetic force and torque on the coil and the further the spring and the pointer are pushed back to achieve balance. Spiral springs have the fortunate property that the deflection of the pointer is proportional to the torque. This means that the scale on the meter can be linear, or evenly spaced.

## DC motors

A DC motor (a simplified example of which is given in the figure at left) uses the current from a battery flowing through a coil in a magnetic field to produce continuous rotation of a shaft. How is this done?

A first attempt at a design might be to remove the restoring spring that is used in a meter.

When a coil is in position 1 (as shown in the top left figure on the opposite page), the forces will make it rotate. As the coil rotates (position 2) the forces remain unchanged in size and direction. This is because the magnetic field and the current in the wire are still the same size and in the same direction. However, their lines of action are closer to the axle, so they have less

### study on

Unit 3

AOS 1

Topic 3

Concept 5

**Simple DC electric motor**  
Summary screen and practice questions

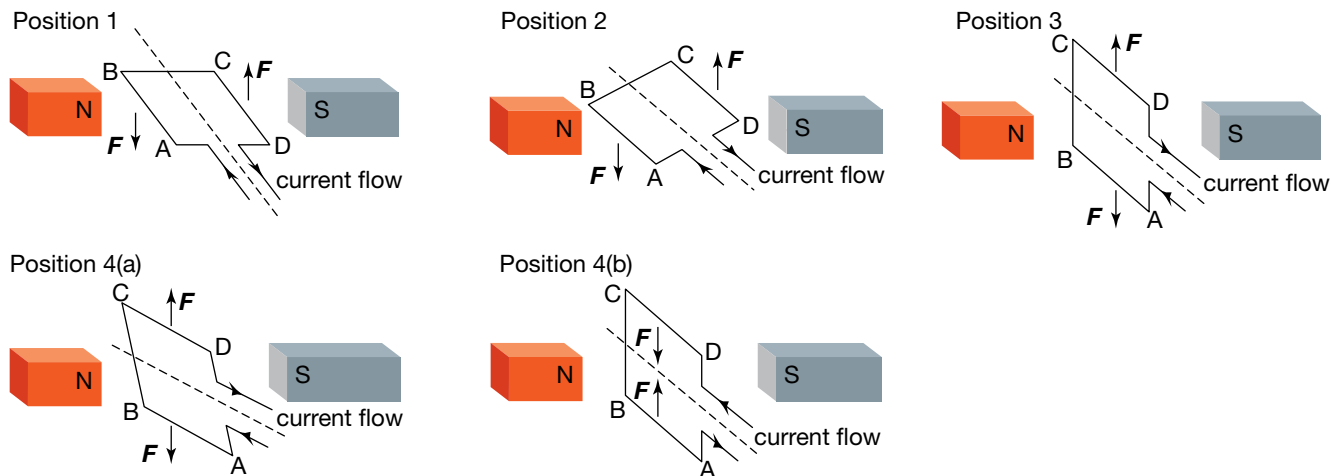

Force on a coil in a DC motor

If this was the design of a DC motor, the coil would turn  $90^\circ$  and then stop! If the coil was in position 3 when the battery was first connected, the coil would not even move.

So, if the motor is to continue to turn, it needs to be modified when the coil reaches position 3. If the direction of the forces can be reversed at this point, as shown in position 4(b), the forces will make the coil continue to turn for another  $180^\circ$ . The coil will then be in the opposite position to that shown for position 3. The current is again reversed to complete the rotation.

The current needs to be reversed twice every rotation when the coil is at right angles to the magnetic field.

This reversal is done with a **commutator**. The commutator consists of two semicircular metal pieces attached to the axle, with a small insulating space between their ends. The ends of the coil are soldered to these metal pieces.

Wires from the battery rest against the commutator pieces. As the axle turns, these pieces turn under the battery contacts, called brushes. This enables the current through the coil to change direction every time the insulating spaces pass the contacts.

Brushes are often small carbon blocks that allow charge to flow and the axle to turn smoothly.



Commutator and coil from a hair dryer

### study on

Unit 3

AOS 1

Topic 3

Concept 5

**Do more**  
Open pipes

A **commutator** is a device that reverses the direction of the current flowing through an electric circuit.

### study on

Unit 3

AOS 1

Topic 3

Concept 6

**The function of a commutator**  
Summary screen and practice questions

## eBookplus

### Weblink

DC motor applet

## eBookplus

### Digital doc

Investigation 6.6  
Electrons in a magnetic field  
doc-18543

## study on

Unit 3

AOS 1

Topic 3

Concept 7

**Magnetic force on a charged particle**

Summary screen and practice questions

## study on

Unit 3

AOS 1

Topic 3

Concept 8

**Low-velocity electron in a magnetic field**

Summary screen and practice questions

## study on

Unit 3

AOS 1

Topic 3

Concept 8

**Do more**  
Electrons in magnetic fields

A DC motor is a device used to turn electrical energy into kinetic energy, usually rotational kinetic energy. As an energy transfer device of some industrial significance, there are some important questions to be asked about the design for a DC motor. Are there some starting positions of the coil that won't produce rotation? How can this be overcome? Can it run backwards and forwards? Can it run at different speeds? Log in to [www.jacplus.com.au](http://www.jacplus.com.au) to locate the DC motor applet weblink for this chapter.

## AS A MATTER OF FACT

The principle of the electric motor was proposed by Michael Faraday in 1821, but a useful commercial motor was not designed until 1873. Direct current (DC) motors were installed in trains in Europe in the 1880s.

## Magnetic force on charges

Electric current consists of electrons moving in a wire. A magnetic field acts on the electrons and pushes them sideways. This force then pushes the nuclei in the wire, and the wire moves. If the moving electrons were in a vacuum, free of the wire, the magnetic field would still exert a force at right angles to their velocity. What would be the effect of this force on a freely moving electron?

When an electron is moving across a magnetic field, it experiences a sideways force, which deflects the movement of the electron. The electron now moves in another direction given by the hand rule; however, it is still moving at right angles to the magnetic field, so the strength of the force is unchanged. The direction of the force will again be at right angles to the electron's motion, and deflecting it again. The deflecting force on the moving electron will be constant in size and will always be at right angles to its velocity. This results in the electron travelling in a circle.

The magnetic force is always at right angles to the direction of the charge's motion. So the magnetic force cannot increase the speed on the charge; it can only change its direction at a constant rate.

The mass spectrometer, the electron microscope and the synchrotron are instruments that use a magnetic force in this manner.

So what is the radius of the circle? How does it depend on the strength of the magnetic field, the speed of the charge and size of the charge?

The magnitude of the magnetic force on a current-carrying wire is given by:

$$F = IlB \quad (1)$$

Imagine a single charge,  $q$ , travelling along at speed,  $v$ . The charge travels through a distance, or length, in a time of  $t$  seconds given by:

$$\begin{aligned} \text{length} &= \text{speed} \times \text{time} \\ l &= vt. \end{aligned} \quad (2)$$

The electric current is given by:

$$\begin{aligned} \text{current} &= \frac{\text{charge}}{\text{time}} \\ I &= \frac{q}{t}. \end{aligned} \quad (3)$$

Substituting equations (2) and (3) into (1):

$$\begin{aligned} F &= \frac{q}{t} \times vt \times B \\ \Rightarrow F &= qvB. \end{aligned}$$

Does this relationship make sense?

What do we observe?	What does the formula predict?	Match
If the charge is stationary, the current is zero, so no force.	If $v = 0$ , then $F = 0$ .	Yes
A stronger magnetic field will deflect the charge more.	Force is proportional to the field.	Yes

The magnitude of the net force on the charged particle as it moves in the magnetic field is:

$$F_{\text{net}} = ma.$$

In this case the only significant force is the magnetic force,  $F = qvB$ .

$$\Rightarrow qvB = ma$$

Because the acceleration is centripetal and constant in magnitude, its magnitude can be expressed as  $a = \frac{v^2}{r}$ , where  $r$  is the radius of the circular motion.

$$\Rightarrow qvB = \frac{mv^2}{r}$$

The expression for the radius is therefore:

$$r = \frac{mv}{Bq}.$$

Does this relationship make sense?

What do we observe?	What does the formula predict?	Match
Hard to turn heavy objects	The heavier the mass, the larger the radius	Yes
Hard to turn fast objects	The faster the object, the larger the radius	Yes
The larger the force, the smaller the radius	The stronger the field, the smaller the radius; the larger the charge, the smaller the radius	Yes

Note that because the direction of the magnetic field is always at right angles to the direction in which the charged particles are moving, the magnetic field cannot make the particles go faster — it can only change their direction. In this context, magnetic fields are not ‘particle accelerators’.

### Sample problem 6.2

An electron travelling at  $5.9 \times 10^6 \text{ m s}^{-1}$  enters a magnetic field of 6.0 mT. What is the radius of its path?

**Solution:**  $m = 9.1 \times 10^{-31} \text{ kg}$ ,  $q = 1.6 \times 10^{-19} \text{ C}$ ,  $v = 5.9 \times 10^6 \text{ m s}^{-1}$ ,  $B = 6.0 \text{ mT}$

$$\begin{aligned} r &= \frac{mv}{Bq} \\ &= \frac{9.1 \times 10^{-31} \text{ kg} \times 5.9 \times 10^6 \text{ m s}^{-1}}{6.0 \times 10^{-3} \text{ T} \times 1.6 \times 10^{-19} \text{ C}} \\ &= 5.6 \times 10^{-3} \text{ m} = 5.6 \text{ mm} \end{aligned}$$

### Revision question 6.3

Calculate the speed of an electron that would move in an arc of radius 1.00 mm in a magnetic field of 6.0 mT.

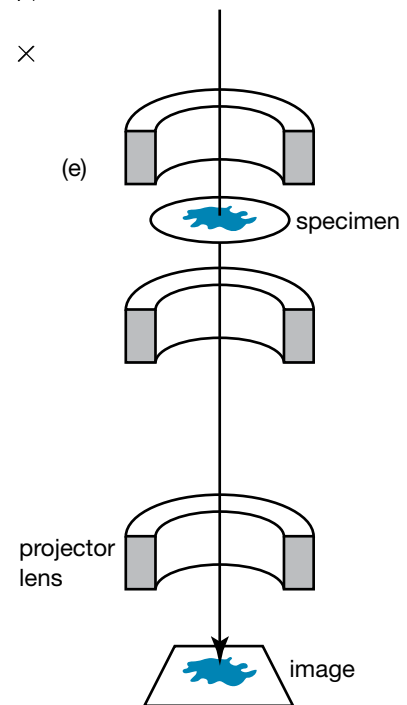
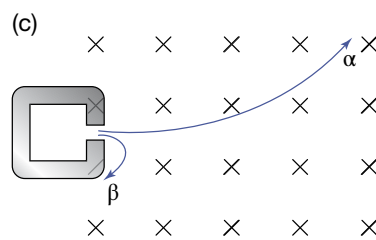
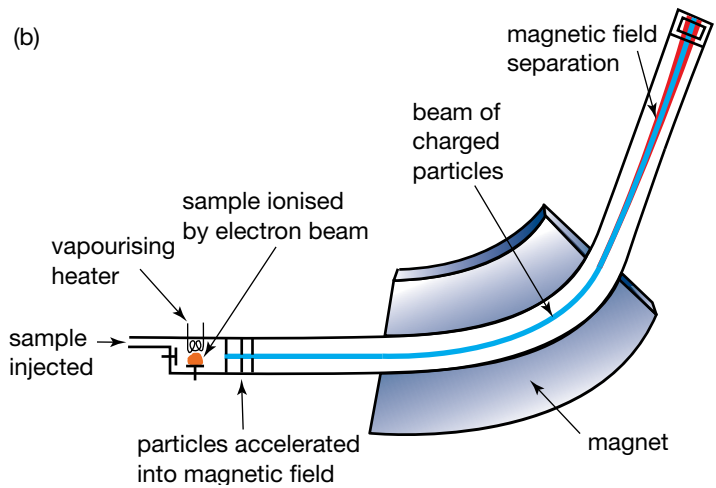

(a) and (b) A mass spectrometer. (c) Positive alpha particles are deflected up and beta particles are deflected down. (d) and (e) An electron microscope.

### AS A MATTER OF FACT

What happens to a stationary electron in a magnetic field? Surprisingly, there is no force! The electron is not moving, so there is, in effect, no current, and therefore no magnetic force. Similarly, the faster the electron moves, the stronger the force. This is a strange situation — that the size of a force on an object is determined by how fast that object is travelling. This raises an interesting conundrum: if you were sitting on an electron moving through a magnetic field, what would you observe? This question can only be resolved by Einstein's Special Theory of Relativity.

## Crossed electric and magnetic fields

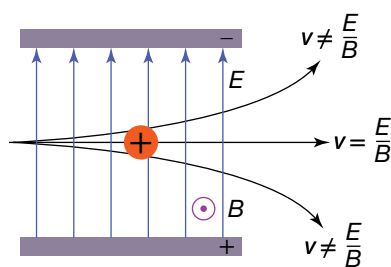

A Wien filter (also known as a velocity selector)

For mass spectrometers and electron microscopes to work, the charged particles all need to be travelling at the same speed. This is because the radius of the path in a magnetic field for a particle with a given charge and mass depends on the particle's speed.

In 1898, Wilhelm Wien (after whom Wien's Law in thermodynamics is named) was investigating the charged particles that are produced when electricity is passed through gases. To investigate their speed and their charge, he set up a magnetic field to deflect the beam of charged particles in one direction, and an electric field to deflect the beam in the opposite direction. For the charged particles that were undeflected, the magnetic force must have been balanced by the electric force.

The electric force on a charge in an electric field is  $F = qE$ , and the magnetic force on a moving charge is  $F = qvB$ . Equating these formulae gives

$$qE = qvB$$

and cancelling  $q$  gives

$$v = \frac{E}{B}$$

This configuration is now called a Wien filter.

### AS A MATTER OF FACT

The aurorae at the North Pole and South Pole are glorious displays of waves of coloured light high in the atmosphere. They are produced when charged particles ejected by the Sun enter Earth's magnetic field. The particles spiral down to the pole, producing an amazing display of light as they move in smaller and smaller circles from the increasing magnetic field.

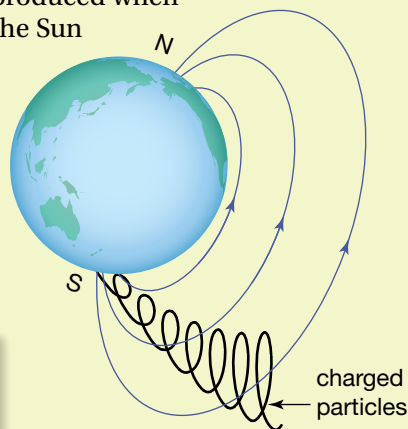

Charged particles entering Earth's magnetic field



Aurora Australis, seen from the International Space Station

## Overview

At the end of chapter 5, gravitational and electrical interactions are compared using four interrelated concepts: force, field, energy and potential. This chapter has not taken that approach for two reasons.

Firstly, although gravitational and electrical interactions involve point objects and scalar properties, the magnetic interaction at its most fundamental is about the magnetic force between two currents. Currents are not point objects; they are vectors. The study of force, field, energy and potential in a magnetic context is too demanding for a secondary Physics course.

Secondly, looking at magnetism from the practical viewpoint of designing a motor helps us to better understand other technological applications of the concepts involved. The understanding of magnetism has enabled the design of devices such as the electric motor, which we have seen in this chapter, and generators and transformers, which are covered in the next two chapters.



# Chapter review

## Summary

- The force exerted by magnets on other magnets and certain elements, including iron, can be explained in terms of a magnetic field. The strength of a magnetic field is measured in tesla (T).
- An electric current in a wire produces a magnetic field. The direction of the magnetic field around a long straight current-carrying wire is given by the right-hand-grip rule. If the right hand grips the current-carrying wire with the thumb pointing in the direction of the current, the fingers curl around the wire in the direction of the magnetic field.
- A magnetic field exerts a force on a wire carrying an electric current. When the magnetic field and electric current are perpendicular to each other, the magnitude of the force can be calculated using the formula  $F = I\ell B$ .
- The direction of the force applied by a magnetic field on a straight current-carrying wire can be determined by the right-hand-slap rule. The hand is held flat with the thumb at right angles to the fingers. The thumb points in the direction of the current, and the fingers in the direction of the magnetic field. The direction of the force applied to the wire by the magnetic field is perpendicularly outwards from the palm.
- In a DC motor, a magnetic field is used to rotate a coil of current-carrying wire around a shaft. The magnetic force produces a torque that turns the coil.
- A commutator is used in a DC motor to reverse the current passing through the coil twice during each rotation. This ensures that the coil keeps rotating in one direction.
- A magnetic field affects moving charge as if it were an electric current in a wire.
- The force by a magnetic field on a moving charged particle is always at right angles to the direction the particle is heading. The force constantly changes the direction of travel, producing a circular path.
- The size of the magnetic force on a moving charged particle is equal to  $qvB$ , where  $q$  and  $v$  are the charge and speed of the particle respectively and  $B$  is the strength of the magnetic field.
- The radius,  $r$ , of the curved path of a charged particle in a magnetic field is given by  $r = \frac{mv}{Bq}$ .

## Questions

### Magnetic fields

1. How would you use a magnet to test whether or not a piece of metal was magnetic?
  2. How could naturally-occurring magnets have been formed?
  3. Why do both ends of a magnet attract an iron nail?
  4. What is the polarity of Earth's magnetic field at the magnetic pole in the southern hemisphere?
  5. When current is connected to a solenoid containing two iron rods side by side, the two rods move apart. Explain why this happens.
  6. Draw the magnetic field lines for the following items (shown below):
    - (a) a loudspeaker magnet
    - (b) a horseshoe magnet.
- (a) Loudspeaker

(b) Horseshoe magnet
7. In Oersted's experiment, the compass needle initially points north-south. What would happen if the current in the wire above the needle ran:
    - (a) west-east
    - (b) east-west?
  8. Use the right-hand-grip rule to determine the direction of the magnetic field at point X in the following diagrams.
 

(a)

(b)

(c)

current out of page  
X
  9. Copy the following diagrams and use the right-hand-grip rule and the direction of the magnetic field at X to determine the direction of the current in the wire in each case.
 

(a)

(b)

(c)

(d)

(e)



10. Use the right-hand-grip rule to determine the direction of the magnetic field at W, X, Y, Z in the following diagrams. Figure (a) represents a circular loop of wire with a current and figure (b) represents a solenoid.

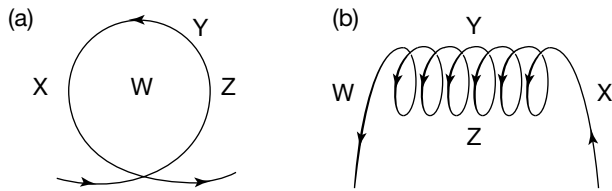

### Magnetic force

11. Use the answer key provided to indicate the direction of the force of the magnetic field on the current-carrying wire in diagrams (a) to (h) below.

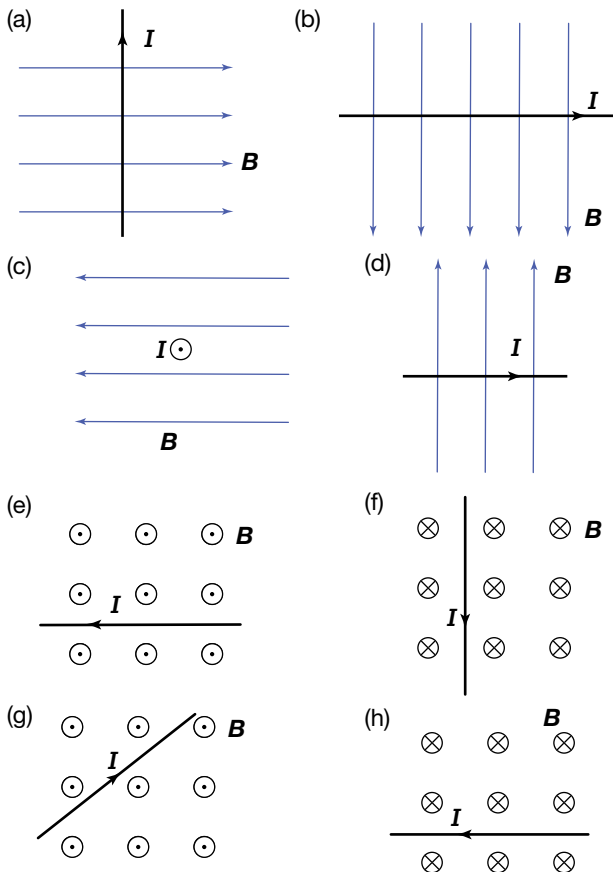
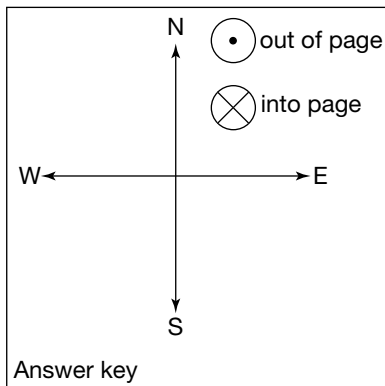

12. Wires A and B are parallel to each other and carry current in the same direction.  
 (a) Draw a diagram to represent this situation, and determine the direction of the magnetic field at B due to wire A.

- (b) This magnetic force will act on the current in wire B. What is the direction of the force by wire A on wire B?  
 (c) Now determine the direction of the magnetic field at A due to wire B and the direction of the force by wire B on wire A.  
 (d) Is the answer to (c) what you expected? Why? (Hint: Consider Newton's laws of motion.)
13. Calculate the size of the force on a wire of length 0.05 m in a magnetic field of strength 0.30 T if the wire is at right angles to the field and it carries a current of 4.5 A.  
 14. Calculate the size of the force of a magnetic field of strength 0.25 T on a wire of length 0.30 m carrying a current of 2.4 A at right angles to the field.  
 15. Calculate the size of the force exerted on a loudspeaker coil of radius 1.5 cm and 500 turns which carries a current of 15 mA in a radial magnetic field of 2.0 T. (Hint: Consider what aspect of the circle takes the place of  $l$  in this question.)  
 16. Calculate the size of the force on a wire carrying a current of 1.8 A at right angles to a magnetic field of strength 40 mT, if the length of the wire is 8.0 cm.  
 17. Design a compass without a permanent magnet.  
 18. Describe a method to use a moving charge to determine the direction of a magnetic field.  
 19. How could a moving electron remain undeflected in a magnetic field?  
 20. Describe and discuss the force of Earth's magnetic field on a horizontal section of a power line that runs in an east-west direction.  
 21. Can a magnetic field move a stationary electron?  
 22. (a) A beam of electrons is directed at right angles to a wire carrying a conventional current from left to right. What happens to the electrons?  
 (b) A beam of electrons is directed parallel to the same wire with the conventional current travelling in the same direction. What happens to the electrons?  
 23. An electron moving north enters a magnetic field that is directed vertically upwards.  
 (a) What happens to the electron?  
 (b) If the electron's motion was inclined upwards at an angle, as well as travelling north, what would be the path of the electron?
- ### DC motors
24. Describe how a DC motor works.  
 25. What is the purpose of each of the following in a DC motor?  
 (a) The magnet  
 (b) The brushes  
 (c) The commutator (mention three aspects)  
 (d) The large number of turns of wires  
 26. Look at the simplified DC motor on page 156.  
 (a) Are there some starting positions of the coil that won't produce rotation? How can this be overcome (Hint: Look at the figures on page 157.)

(b) Can the DC motor run backwards and forwards?

(c) Can it run at different speeds? If so, how?

27. (a) Would a DC motor work if it was connected to an alternating current (AC) power source?

(b) What if there was no commutator?

28. Stronger magnetic fields can be obtained with an electromagnet. The same DC power source can supply current to the electromagnet as well as to the rotating coil. The two components of the circuit, the electromagnet and the rotating coil, can be connected to the power source in two different ways.

(a) What are these ways?

(b) How do you think the starting and operating characteristics of these two types will differ?

### Charges in a magnetic field

29. An electron travelling east at  $1.2 \times 10^5 \text{ m s}^{-1}$  enters a region of uniform magnetic field of strength 2.4 T.

(a) Calculate the size of the magnetic force acting on the electron.

(b) Describe the path taken by the electron, giving a reason for your answer.

(c) Calculate the magnitude of the acceleration of the electron.

30. (a) What is the size of the magnetic force on an electron entering a magnetic field of 250 mT at a speed of  $5.0 \times 10^6 \text{ m s}^{-1}$ ?

(b) Use the mass of the electron to determine its centripetal acceleration.

(c) If a proton entered the same field with the same speed, what would be its centripetal acceleration?

31. Determine the direction of the magnetic force in the following situations, using your preferred hand rule. Use the following terminology in your answers: up the page, down the page, left, right, into the page, out of the page.

(a) Magnetic field into the page, electron entering from left

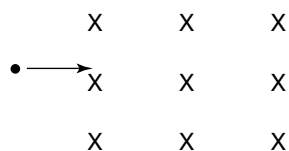

(b) Magnetic field down the page, electron entering from left

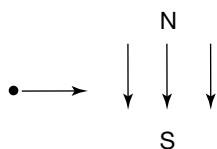

(c) Magnetic field out of the page, proton entering obliquely from left

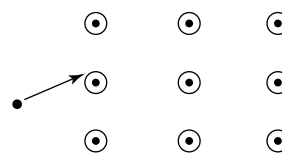

32. An ion beam consisting of three different types of charged particle is directed eastwards into a region having a uniform magnetic field,  $B$ , directed out of the page. The particles making up the beam are (i) an electron, (ii) a proton and (iii) a helium nucleus or alpha particle. Copy the following figure and draw the paths that the electron, proton and helium nucleus could take.

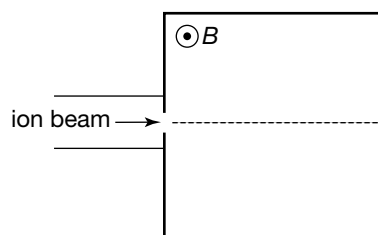

33. In a mass spectrometer, positively charged ions are curved in a semicircle by a magnetic field to hit a detector at different points depending on the radius and mass. The ions enter the chamber at the top left corner, and curve around to hit the detector (see below). What should be the direction of the magnetic field for the spectrometer to work properly? Use the answers from question 32.

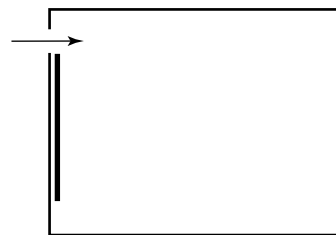

34. Calculate the radius of curvature of the following particles travelling at 10% of the speed of light in a magnetic field of 4.0 T.

(a) An electron

(b) A proton

(c) A helium nucleus

35. What magnetic field strength would cause an electron travelling at 10% of the speed of light to move in a circle of 10 cm?

36. What strength of magnetic field would be needed to obtain a radius of 1000 m if an electron has momentum of  $1.0 \times 10^{-18} \text{ kg m s}^{-1}$ ? (Assume the direction of the momentum of the electrons is perpendicular to the direction of the magnetic field.)

37. The storage ring of the Australian Synchrotron has a radius of 34.4 m and the strength of the

magnetic field is 2.0 T. What is the momentum of an electron in the storage ring?

- 38.** Would the same configuration of crossed electric and magnetic fields shown on page 161 work for negatively charged particles?
- 39.** Design a velocity selector with a magnetic field down the page, assuming the charged particles are coming from the left.
- 40.** (a) Calculate the speed acquired by an electron accelerated by a voltage drop of 100 V.  
(b) The electron from part (a) enters a velocity selector with a magnetic field of strength 6.0 mT. For what electric field strength would the electron be undeflected?  
(c) If the plate separation for the electric field was 5.0 cm, what is the voltage across the plates?

# Generating electricity

## REMEMBER

Before beginning this chapter, you should be able to:

- describe how a magnetic field exerts a force on a current
- describe the operation of a simple DC motor, including the role of the commutator.

## KEY IDEAS

After completing this chapter, you should be able to:

- determine the amount of magnetic flux passing through an area
- explain how a moving conductor in a magnetic field generates a voltage drop
- describe how the magnetic flux through a rotating coil changes with time
- explain how a rotating loop in a magnetic field generates a voltage that varies as a sine wave — that is, an AC voltage
- determine the average induced voltage in a loop from the flux change and the time in which the change took place
- determine the direction of the induced current in a loop, using Lenz's Law
- calculate the average induced voltage for more than one loop
- describe and determine the following properties of an AC voltage: frequency, period, amplitude, peak-to-peak voltage, peak-to-peak current, RMS voltage and RMS current
- interpret RMS in terms of the DC supply that delivers the same power as the AC supply
- describe the operation of an alternator with the use of slip rings to produce AC, and the operation of a generator with a split-ring commutator to produce fluctuating DC.



A generator inside a wind turbine

## Making electricity

Chapter 6 describes how a magnetic field exerts a force on a moving charge, either in a wire as part of an electric current or as a free charge. This chapter applies this idea to new situations to produce or generate electricity. In doing this, a new concept, magnetic flux, will be developed to explain how a generator works.

### Generating voltage with a magnetic field

What should happen when a metal rod moves through a magnetic field? Imagine a horizontal rod falling down through a magnetic field as shown in the figure at left.

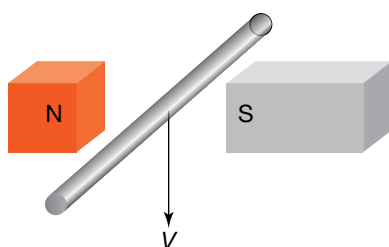

A metal rod falling down through a magnetic field

As the rod falls, the electrons and the positively charged nuclei in the rod are both moving down through the magnetic field. As was explained in the last chapter, the magnetic field will therefore exert a magnetic force on the electrons, and on the nuclei.

In which direction will the magnetic force act on the electrons and the nuclei?

The hand rules from chapter 6 can be used for both the electrons and the nuclei, keeping in mind that the hand rules use conventional current, so electrons moving down are equivalent to positive charges moving up.

The force on the electrons will be towards the far end of the rod, while the force on the nuclei will be to the near end of the rod, as is shown in the figure below.

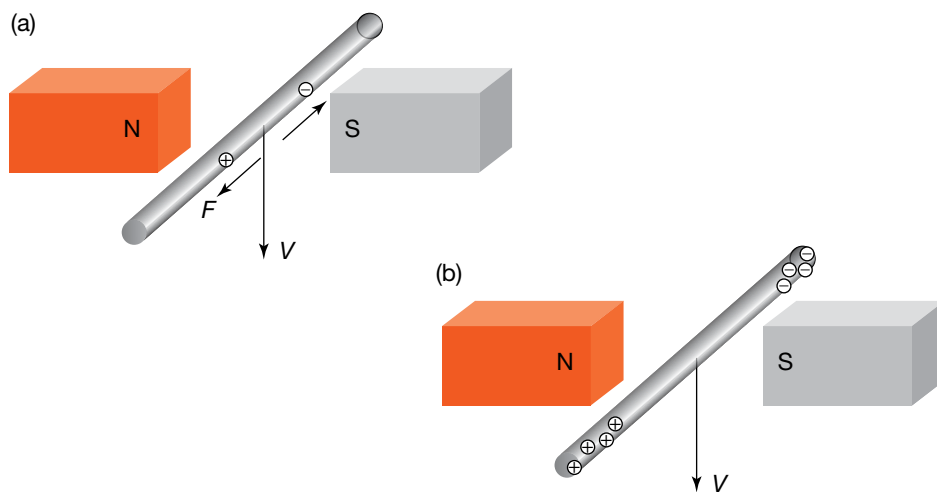

The magnetic field forces electrons to the far end of the falling rod.

The atomic structure of the metal restricts the movement of the positively charged nuclei. The negatively charged electrons, on the other hand, are free to move. The electrons move towards the far end of the rod, leaving the near end short of electrons and thus positively charged.

Not all electrons move to the far end. As the far end becomes more negative, there will be an increasingly repulsive force on any extra electrons. Similarly, there will be an increasingly attractive force from the positively charged near end, attempting to keep the remaining electrons at that end. This process is similar to the charging of a capacitor.

The movement of the metal rod through the magnetic field has resulted in the separation of charge, causing a voltage between the ends. This is called **induced voltage**. As long as the rod keeps moving, the charges will remain

**Induced voltage** is a voltage that is caused by the separation of charge due to the presence of a magnetic field.

An **emf** is a source of voltage that can cause an electric current to flow.

separated. As soon as the rod stops falling, the magnetic force is reduced to zero; electrons are then attracted back to the positive end and soon the electrons in the rod are distributed evenly.

The charge in the moving rod is separated by the magnetic field, but the charge has nowhere to go. A source of voltage, an **emf** (electromotive force), has been produced. It is like a DC battery with one end positive and the other negative.

What determines the size of this induced emf? The size depends on the number of electrons shifted to one end. The electrons are shifted by the magnetic force until their own repulsion balances this force. So, the larger the magnetic force pushing the electrons, the more there will be at the end.

The size of this pushing magnetic force, as seen in chapter 6, depends on the size of the magnetic field and the current. In this case, the size depends on how fast the electrons are moving down with the rod (which is, of course, how fast the rod is falling). So the faster the rod falls, the larger the emf.

An expression for the induced emf can be obtained by combining the expression from the end of the last chapter for the force on a moving charge with the definition of voltage from book 1. When the rod is moving down with speed ( $v$ ) each electron experiences a sideways force along the rod equal to  $Bqv$ . This force pushes the electron along the length ( $l$ ) of the rod and so is doing work in separating charge. The amount of work done is equal to the force times the distance and so equals  $Bqvl$  and is measured in joules. However the definition of emf or the voltage drop across the rod is energy supplied per unit of charge, measured in joules per coulomb or volts. So the induced emf ( $\mathcal{E}$ ) is given by  $\frac{Bqvl}{q}$ , which gives:

$$\mathcal{E} = Blv$$

where

$\mathcal{E}$  is the induced emf measured in volts

$B$  is the magnetic field strength in tesla

$l$  is the length of the rod or wire in metres that is in the magnetic field

$v$  is the speed in metres per second at which the rod or wire is moving across the magnetic field.

### Sample problem 7.1

A 5.0 cm metal rod moves at right angles across a magnetic field of strength 0.25 T at a speed of 40 cm s<sup>-1</sup>. What is the size of the induced emf across the ends of the rod?

**Solution:**  $l = 5.0 \text{ cm} = 5.0 \times 10^{-2} \text{ m}$ ,  $v = 40 \text{ cm s}^{-1} = 0.4 \text{ m s}^{-1}$ ,  $B = 0.25 \text{ T}$

$$\begin{aligned}\mathcal{E} &= Blv \\ &= 0.25 \text{ T} \times 5.0 \times 10^{-2} \text{ m} \times 0.4 \text{ m s}^{-1} \\ &= 5.0 \times 10^{-3} \text{ V} = 5.0 \text{ mV}\end{aligned}$$

### Revision question 7.1

At what speed would the rod need to move to induce an emf of 1.0 V?

## Generating a current

Emfs can be used to produce a current. The experimental design illustrated in the first figure for 'Generating voltage with a magnetic field' (page 167) can be modified to produce a current by attaching a wire to each end of the metal rod

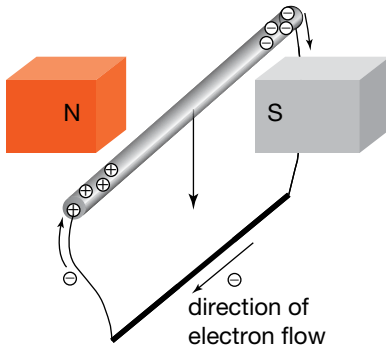

The accumulated electrons at the far end of a rod move to the positive near end of the rod through the connecting wire.

and connecting these wires outside the magnetic field. (See the figure at left.) Now the electrons have the path of a low-resistance conductor to go around to the positively charged end.

Once the electrons reach the positive end, they will be back in the magnetic field, falling down with the metal rod, and will again experience a magnetic force pushing them to the far end of the rod. The electrons will then move around the circuit for a second time.

The electrons will continue to go around as long as the wire is falling through the magnetic field. An electric current has been generated!

## The source of a current's electrical energy

Electric current has electrical energy. Where did this energy come from? Before the rod (discussed earlier) was released, it had gravitational potential energy. If it is dropped outside the magnetic field (see figure (b) below), this gravitational potential energy is converted into kinetic energy. If it is dropped inside the magnetic field (see figure (a) below), some electrical energy is produced. Since energy is conserved (that is, it cannot be created or destroyed), there must be less kinetic energy in the rod falling in the magnetic field. That is, the rod in the magnetic field is falling slower. Why?

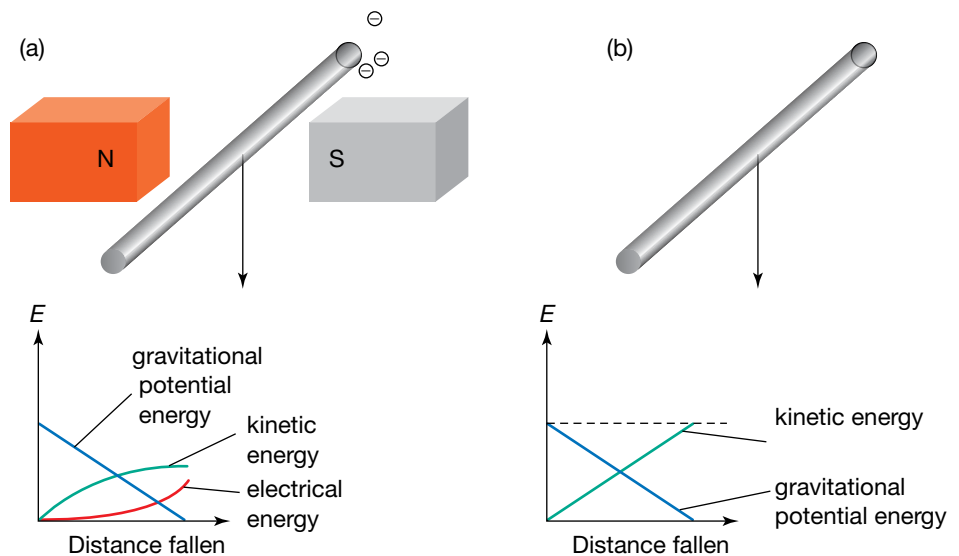

(a) Inside the magnetic field, the gravitational potential energy of the falling rod is converted into both kinetic energy and electrical energy, whereas (b) outside the magnetic field it is converted only into kinetic energy.

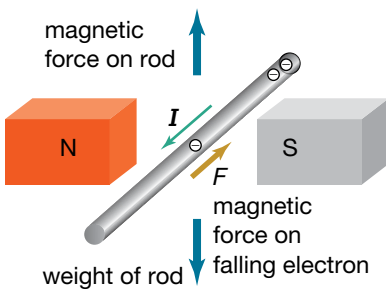

The magnetic force opposes the weight of the rod.

The induced current in the falling rod means that when the electrons are in the rod they are moving in two directions — downwards with the rod and along the rod.

The downward movement produced the sideways force along the rod that keeps the current going. But if the electrons are also moving along the rod, how does the magnetic field respond to this?

The movement of electrons along the rod is also at right angles to the magnetic field so the field exerts a second force on the electrons. The direction of this force is once again given by the hand rule and is directed upwards. This magnetic force opposes the accelerating force of the weight of the rod. (See the figure at left.)

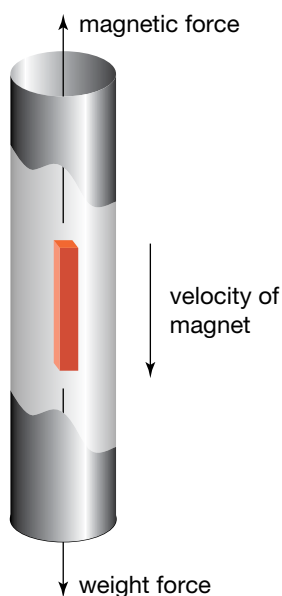

A magnet falling through a metal tube falls with an acceleration less than  $9.8 \text{ m s}^{-2}$  because it experiences a retarding magnetic force.

A **galvanometer** is an instrument used to detect small electric currents.

**Electromagnetic induction** is the generation of an electric current in a coil as a result of a changing magnetic field or as a result of the movement of the coil within a constant magnetic field.

The size of the upward magnetic force depends on the size of the current. This current will depend, in turn, on the size of the voltage between the ends of the rod. Voltage will increase as the rod moves faster.

When the rod first starts falling, the magnetic force opposing the weight is small, but as the rod falls faster the opposing magnetic force increases until it equals the weight of the rod. At this point the rod has reached a maximum steady speed. This situation is identical to the terminal velocity experienced by objects falling through the air.

As the metal rod falls through the magnetic field at constant speed, the loss in gravitational potential energy is converted to electrical energy as the generated emf drives the current through the resistance of the circuit.

This effect is difficult to demonstrate in practice. (A magnetic field large enough for the rod to achieve terminal velocity is too difficult to construct.) However, it is possible to drop a magnet through a cylindrical conductor. With a sufficiently strong magnet, measurable slowing-down against the acceleration due to gravity can be observed.

## Faraday's discovery of electromagnetic induction

Michael Faraday was aware of the magnetic effect of a current and he spent six years searching for the reverse effect — that is, the electrical effect of magnetism.

His equipment consisted of two coils of insulated wire, wrapped around a wooden ring. One coil was connected to a battery, the other to a **galvanometer**, a sensitive current detector. Faraday observed that the galvanometer needle gave a little kick when the battery switch was closed and a little kick the opposite way when the switch was opened. The rest of the time, either with the switch open or closed, the needle was stationary, reading zero. The current was momentary, not the constant current he was looking for. What Faraday had observed came to be called **electromagnetic induction**.

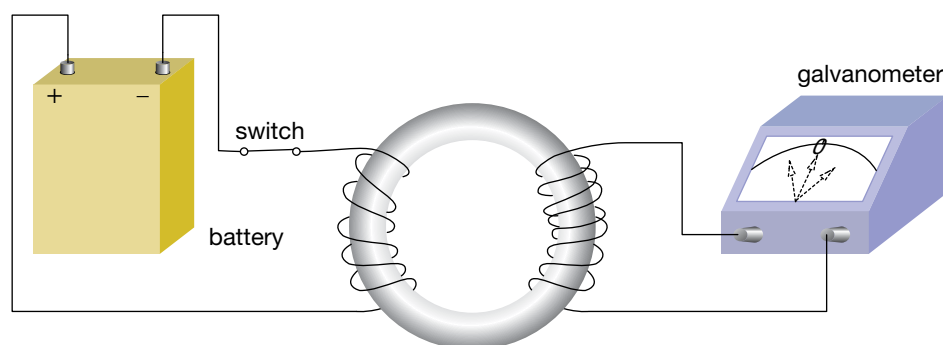

When the switch in the battery circuit is opened or closed, there is a momentary current through the galvanometer.

### eBookplus

**Digital doc**  
Investigation 7.1  
Inducing a current  
doc-18544

Investigating further, Faraday found that using an iron ring instead of a wooden one increased the size of the current. He concluded that when the magnetic field of the battery coil was changing, there was a current induced in the other coil.

He therefore replaced the battery coil with a magnet. Moving the magnet through the other coil changed the magnetic field and produced a current. The faster the magnet moved, the larger the current. When the magnet was moved back away from the coil, current flowed in the opposite direction.



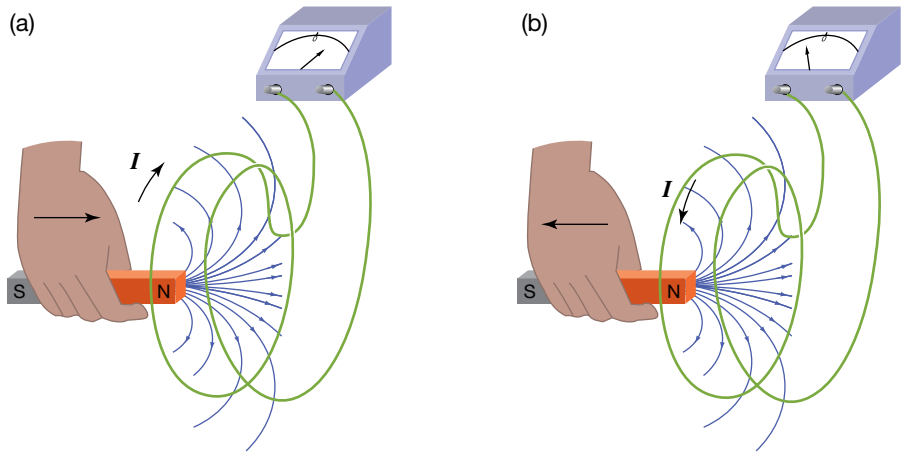

Magnet (a) moving into a coil and (b) away again

If there was an induced current, then there must have been an induced emf. An emf gives energy to a charge to move it through the wire, and the resistance of the wire limits the size of the current. So it is more correct to say that the changing magnetic field induced an emf.

## Magnetic flux

**Magnetic flux** is a measure of the amount of magnetic field passing through an area. It is measured in webers (Wb).

**Magnetic flux** is the amount of magnetic field passing through an area, such as a coil. It is the change in the magnetic flux that will help explain electromagnetic induction.

The stronger the magnetic field going through an area, the larger the amount of magnetic flux. Similarly, the larger the area the magnetic field is going through, the larger the magnetic flux.

This is summarised in the definition of magnetic flux:

$$\text{amount of magnetic flux } (\Phi_B) = \text{strength of magnetic field } (\mathbf{B}) \times \text{the area } (A)$$

$$\Phi_B = \mathbf{B}A.$$

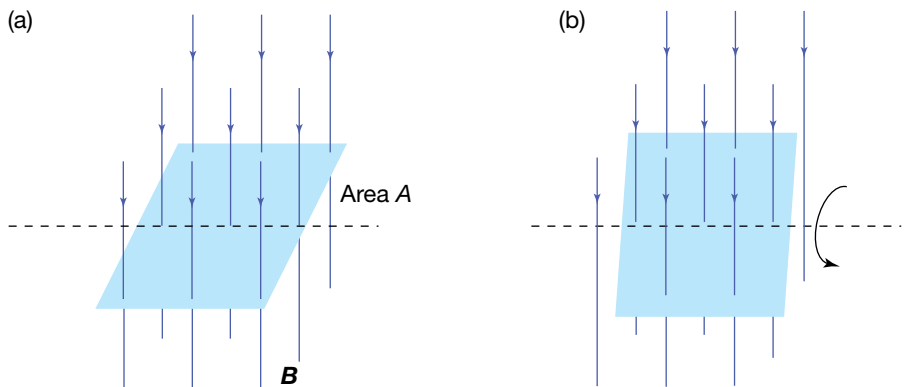

Magnetic flux is the amount of magnetic field passing through an area. In (a) it is the maximum  $\mathbf{B}A$ ; in (b) the value is less, as fewer field lines pass through the coil.

Magnetic flux is measured in webers. One weber (Wb) is the amount of magnetic flux from a uniform magnetic field with a strength of 1.0 tesla passing through an area of 1.0 square metre. The magnetic flux can also take on positive and negative values, depending on which side of the area the magnetic field is coming from.

### study on

Unit 3

AOS 2

Topic 1

Concept 1

**Magnetic flux**  
Summary screen  
and practice  
questions

### study on

Unit 3

AOS 2

Topic 1

Concept 1



**See more**  
Magnetic flux

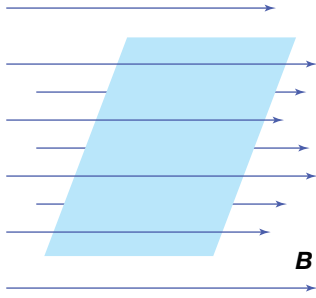

Zero magnetic flux, as no field lines 'thread' the loop

This description has assumed that the magnetic field is at right angles to the area, as shown in figure (a). If the magnetic field went through the area at an angle less than  $90^\circ$  (as shown in figure (b)), the amount of magnetic flux passing through the area would be less. In fact, if the magnetic field is parallel to the area, the amount of magnetic flux will be zero, as none of the magnetic field lines pass through the area from one side to the other.

A more correct definition of magnetic flux would therefore be:

amount of magnetic flux ( $\Phi_B$ ) = component of magnetic field strength perpendicular to the area ( $B_\perp$ )  
 $\times$  the area ( $A$ )

$$\Phi_B = B_\perp \times A.$$

### Sample problem 7.2

Calculate the magnetic flux in each of the following situations.

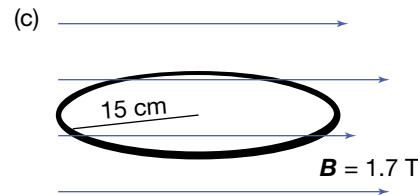
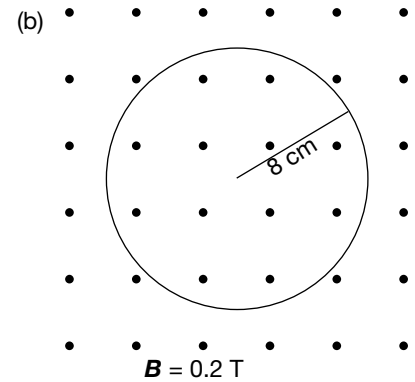
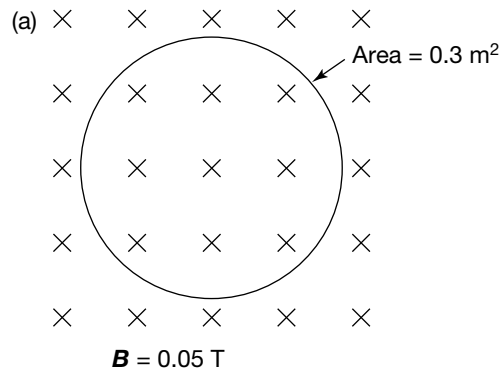

**Solution:** (a)  $\Phi_B = B_\perp \times A$   
 $= 0.05 \text{ T} \times 0.3 \text{ m}^2$   
 $= 0.015 \text{ Wb}$

(b) First calculate area  $A$ . (Don't forget to convert the radius to metres.)  
 $A = \pi r^2$   
 $= \pi \times (0.08 \text{ m})^2$   
 $= 0.020106 \text{ m}^2$  (Don't round off the final answer.)

Now calculate the flux:

$$\Phi_B = B_\perp \times A$$

$$= 0.2 \text{ T} \times 0.020106 \text{ m}^2$$

$$= 0.004 \text{ Wb}$$

(c) Note that the plane of the loop is parallel to the magnetic field,

$$B_\perp = 0.$$

$$\Phi_B = B_\perp \times A$$

$$= 0 \times A$$

$$= 0 \text{ Wb}$$

### study on

Unit 3

**Faraday's Law**

AOS 2

Summary screen and practice questions

Topic 1

Concept 2

### study on

Unit 3



AOS 2

Topic 1

**Do more**

Generating an emf

Concept 2

### eBook plus

#### eLesson

Magnetic flux and Lenz's Law

eles-0026

#### Interactivity

Magnetic flux and Lenz's Law

int-0050

### study on

Unit 3

**Induced emf from a flux-time graph**

AOS 2

Summary screen

Topic 1

and practice questions

Concept 3

### study on

Unit 3

**Lenz's Law**

AOS 2

Summary screen and practice questions

Topic 1

Concept 4

### study on

Unit 3



AOS 2

**See more**

Magnetic flux and

Lenz's Law

Concept 4

## Revision question 7.2

Estimate the maximum amount of magnetic flux passing through an earring when placed near a typical school magnet.

## Induced EMF

Now the concept of magnetic flux can be used to explain the induced emf. The two principles are described here.

1. An emf is induced in a coil when the amount of magnetic flux passing through the coil changes.
2. The size of the emf depends on how quickly the amount of magnetic flux changes.

These two statements can be written formally as:

$$\text{emf}_{\text{average}}, \varepsilon = \frac{\Delta\Phi_{\text{B}}}{\Delta t}$$

This statement is known as Faraday's Law. The word 'average' is included because the change in magnetic flux took place over a finite interval of time.

Lenz's Law states: *The direction of the induced current is such that its magnetic field is in the opposite direction to the change in magnetic flux.* It can be incorporated in the above equation as a minus sign:

$$\text{emf}, \varepsilon = \frac{-\Delta\Phi_{\text{B}}}{\Delta t}$$

If the coil consists of several turns of wire, the equation can be generalised further:

$$\text{emf}, \varepsilon = \frac{-N\Delta\Phi_{\text{B}}}{\Delta t}$$

where

$N$  is the number of turns in the coil.

In part (a) of the following figure there is no magnetic flux passing through the loop. When the magnet approaches the coil (figure (b)), there is an increase in the amount of magnetic field passing through it from left to right. The loop has experienced a change in the magnetic flux passing through it (c), and the direction of this change is from left to right. The direction of the induced magnetic field (d) from the induced current in the loop (e) will be such that its magnetic effect will oppose the change in the magnetic flux (c). This means its direction will be from right to left.

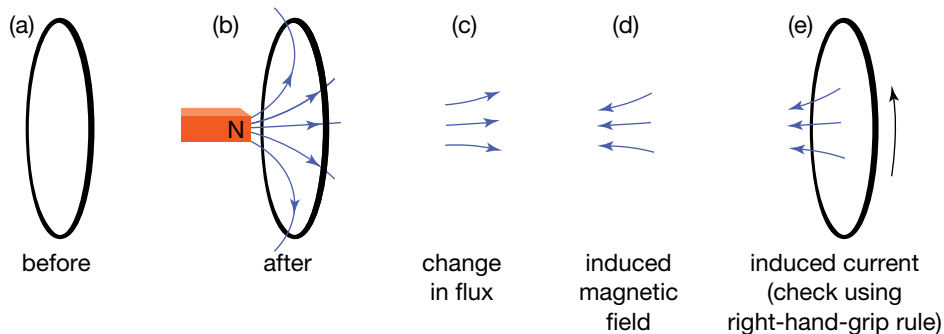

The loop (a) before and (b) after; (c) change in flux, (d) direction of induced field and (e) direction of current

To achieve an induced magnetic field from right to left, the induced current, using the right-hand-grip rule, must be travelling up the front of the loop.

## study on

Unit 3

AOS 2

Topic 1

Concept 4



**Do more**  
Magnetic flux and  
Lenz's Law

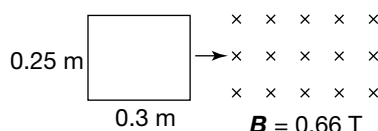

**Solution:**

(a) First calculate the area of the loop.

$$\begin{aligned} A &= 0.25 \text{ m} \times 0.3 \text{ m} \\ &= 0.075 \text{ m}^2 \end{aligned}$$

Now find the change in flux.

$$\begin{aligned} \Delta\Phi_B &= \Phi_{B \text{ final}} - \Phi_{B \text{ initial}} \\ &= (BA)_{\text{final}} - (BA)_{\text{initial}} \\ &= (0.66 \text{ T} \times 0.075 \text{ m}^2) - (0 \text{ T} \times 0.075 \text{ m}^2) \\ &\quad \text{(The initial field strength through the coil is zero.)} \\ &= (0.05 \text{ T m}^2) - (0 \text{ T m}^2) \\ &= 0.05 \text{ Wb into the page} \end{aligned}$$

Finally, using Faraday's Law:

$$\begin{aligned} \text{emf, } \varepsilon &= \frac{-N\Delta\Phi_B}{\Delta t} \\ &= -1 \times \frac{0.05 \text{ Wb}}{2.0 \text{ s}} \\ &= -0.025 \text{ V} \end{aligned}$$

So the magnitude of the induced voltage is 0.025 V.

The minus sign is there to indicate that the induced emf opposes the change in magnetic flux.

(b) Change in flux = final – initial = flux into the page

Direction of induced magnetic field = out of the page (Lenz's Law)

Direction of induced current = anticlockwise (right-hand-grip rule)

### Revision question 7.3

A spring is bent into a circle and stretched out to a radius of 5.0 cm. It is then placed in a magnetic field of strength 0.55 T. The spring is released and contracts down to a circle of radius 3.0 cm. This happens in 0.15 seconds.

(a) What is magnitude of the induced emf?

(b) In what direction does the current move?

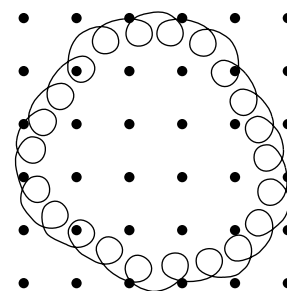

## Rotating a loop

A magnet moving in and out of a coil to generate a current is not a very efficient means of converting the mechanical energy of the moving magnet into electrical energy of a current in the coil. It does not have much technological potential; an alternative is needed.

Another way of changing the amount of magnetic flux passing through a loop is to rotate a loop in a magnetic field.

When the loop is 'face on' to the magnetic field, the maximum amount of magnetic flux is passing through the loop. As the loop turns, the amount decreases. When it has turned  $90^\circ$ , there is no flux passing through it at all. As the loop continues to turn, the magnetic field passes through the loop from the other side: a negative amount of flux, from the point of view of the loop.

As the loop turns further still, the amount of magnetic flux passing through the loop reaches a negative maximum, then comes back to zero, and finally passes through the original face of the loop.

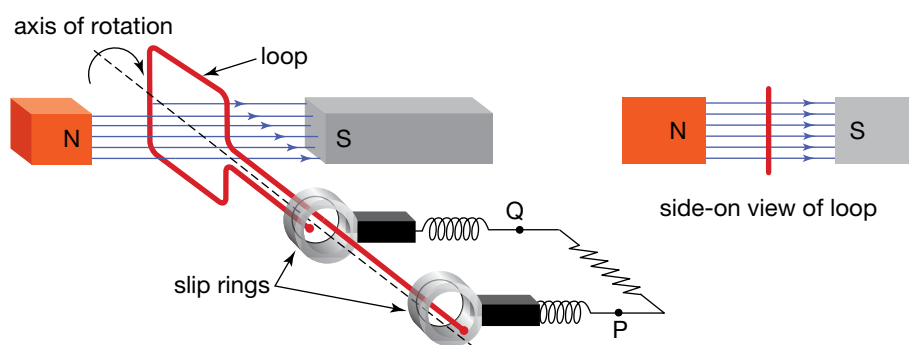

A loop 'face on' to a magnetic field has maximum magnetic flux.

The amount of magnetic flux passing through the loop varies like a sine wave. The induced emf across the ends of the loop is equal to the change of magnetic flux with time. In mechanics, the velocity is defined as the change of displacement over time and it is shown as the gradient of the displacement-time graph. Similarly the induced emf is shown as the gradient of a magnetic flux-time graph, which is also a sine wave.

The emf graph is the same shape as the flux graph (see the figure at left) but shifted sideways, so that when the flux is a maximum, the emf is zero. (At this point the flux-time graph is flat, so the gradient is zero.)

Similarly, when the flux is zero, the flux-time graph is steepest, so the gradient is a maximum and the emf is a maximum.

Which way does the current travel in the loop? From which connection, P or Q, does the current leave the loop to go around the external circuit? This is not easy to determine. It can be worked out using Lenz's Law or using the magnetic force of electrons in the loop. This is shown below.

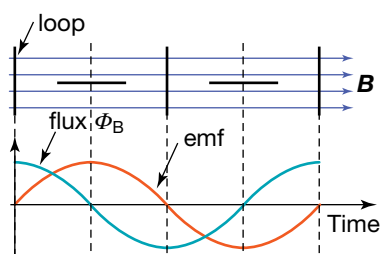

Flux-time graph

## Using Lenz's Law

As the loop passes through the horizontal plane the magnetic flux changes from passing through one side to passing through the other.

In part (a) of the following figure, the magnetic flux is entering the loop from above. In part (b), it enters from below. The change in magnetic flux is therefore upwards. The induced magnetic field will then be down at this point. To produce this field, the conventional current needs to run in the order ABCD.

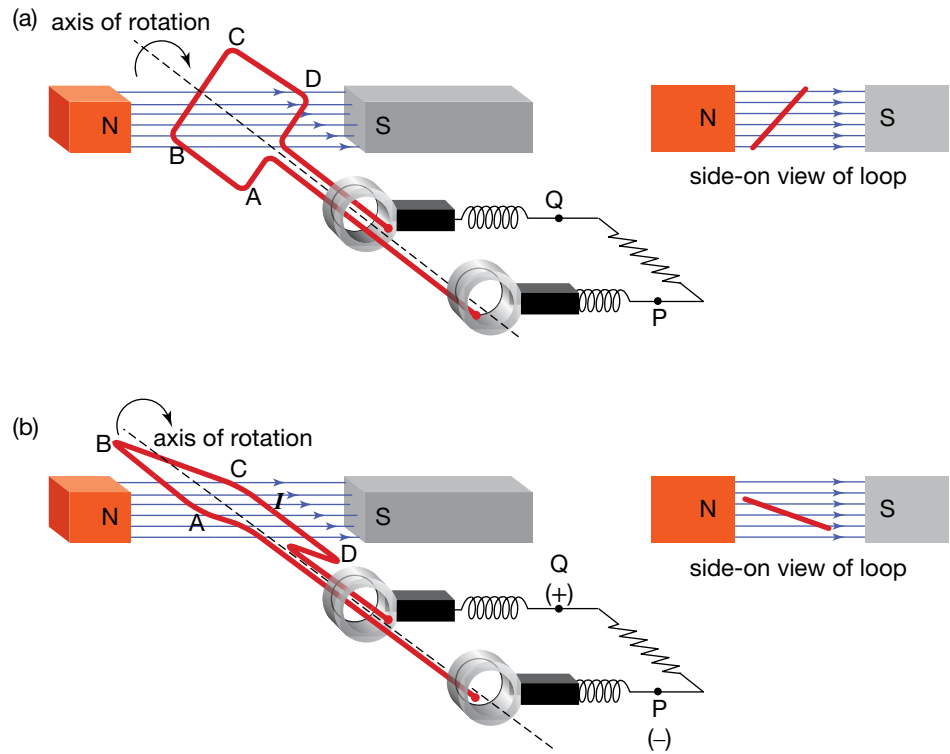

Direction of current flow as loop passes through the horizontal position

At this point in the rotation, the current will enter the external circuit from the slip ring at Q and return to the loop by the slip ring at P. So, for the time being, Q is the positive terminal and P the negative.

In the diagrams above, the wire from A is attached to the front metal ring, the one connected to P, and the wire from B is attached to the back ring, the one connected to Q. These connections are fixed. When the loop rotates about its axis, the two slip rings also rotate about the same axis. The black blocks are made of graphite. They are being held in place against the spinning slip rings by the springs. Graphite is used because it not only conducts electricity but is also a lubricant. The spinning slip rings easily slide past the fixed block. The blocks are also called 'brushes' because early designs used thin metal strips that rested against the slip rings.

### eBook plus

**Weblink**  
Generator applet

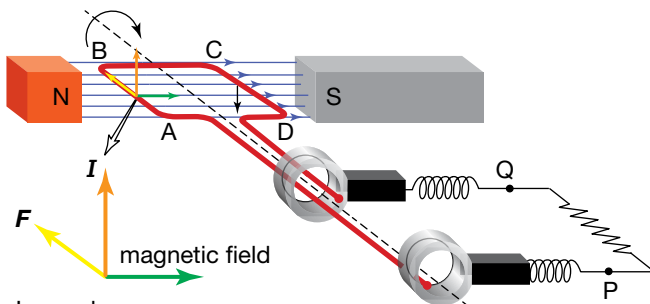

Using your left-hand rule to determine current direction in a rotating loop

## Using magnetic force on the charges in the wire

As the loop passes through the horizontal plane, the left side of the loop, AB (see the figure at left), is moving up and the right side, CD, is moving down. The force of the magnetic field on the positive charges in AB will be towards B, while the force on the electrons in AB will be towards A.

Similarly, the positive charges in CD will be pushed to D, while the electrons will be pushed towards C.

This means that conventional current will flow ABCD, while the electrons will travel around the loop in the order DCBA. The conventional current will leave the external circuit from D and return to the loop by A. This is the same result obtained as with the previous method.

An **alternating current** is an electric current that reverses direction at short, regular intervals.

A **generator** is a device in which a rotating coil in a magnetic field is used to produce a voltage.

A **direct current** is an electric current that flows in one direction only.

### study on

Unit 3

AOS 2

Topic 1

Concept 5

**Principles of an electricity generator**

Summary screen and practice questions

The sinusoidal emf drives current through the external circuit first one way, then the opposite way, and is thus called **alternating current** (AC).

This design of a rotating coil in a magnetic field is called a **generator**. If the ends of the coil are connected to slip rings, then the voltage across the external connections is alternating in direction, producing an alternating current. The device is now called an alternator.

If the slip rings are replaced by a split ring used in a DC motor, the current reverses every half-cycle, and so the alternating current is converted into pulsating **direct current** (DC). The device is now called a DC generator.

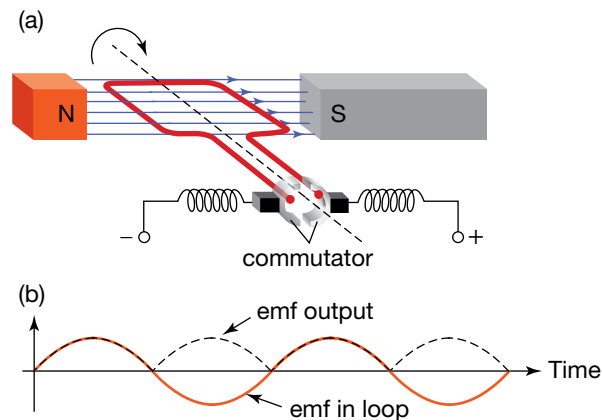

AC voltage coming from loop, and DC coming from commutator

## Peak, RMS and peak-to-peak voltages

The voltage output of an AC generator varies with time, producing a sinusoidal signal. This signal, shown in the figure below, can be described in terms of the physical quantities described below.

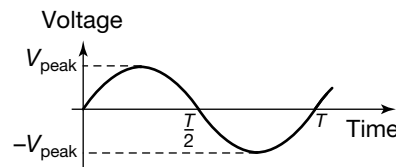

Sinusoidal signal from voltage output of an AC generator

The **period**,  $T$ , of a periodic wave is the time it takes a source to produce a complete wave. This is the same as the time taken for a complete wave to pass a given point.

The **frequency**,  $f$ , of a periodic wave is the number of times that it repeats itself every second.

The **amplitude** of a periodic disturbance is the maximum variation from zero.

The **peak voltage**,  $V_{\text{peak}}$ , is the amplitude of an alternating voltage.

The **peak current**,  $I_{\text{peak}}$ , is the amplitude of an alternating current.

The **RMS** (root mean square) **voltage**,  $V_{\text{RMS}}$ , is the value of the constant DC voltage that would produce the same power as AC voltage across the same resistance.

- The **period**,  $T$ , is the time taken for one complete cycle.
- The **frequency**,  $f$ , is the number of full cycles completed in one second. The frequency is related to the period by the equation:

$$T = \frac{1}{f}$$

The frequency of the power supplied to households is 50 Hz (1 hertz is one cycle per second). The period is therefore  $\frac{1}{50}$  per second = 0.02 s.

- The **amplitude** is the maximum variation of the voltage output from zero. It is called the **peak voltage**,  $V_{\text{peak}}$ . Similarly, the amplitude of the current is called the **peak current**,  $I_{\text{peak}}$ .
- The **RMS** (root mean square) **voltage**,  $V_{\text{RMS}}$ , is the value of the constant DC voltage that would produce the same power as the AC voltage across

## study on

Unit 3

**The alternator  
– an AC  
generator**

AOS 2

Topic 1

Summary screen  
and practice  
questions

Concept 6

The **peak-to-peak voltage**,  $V_{p-p}$ , is the difference between the maximum and minimum voltages of a DC voltage.

## study on

Unit 3

**The DC  
generator**

AOS 2

Topic 1

Summary screen  
and practice  
questions

Concept 7

the same resistance. The RMS voltage is related to the peak voltage by the equation:

$$V_{\text{RMS}} = \frac{V_{\text{peak}}}{\sqrt{2}}.$$

The peak voltage of a 230 V RMS household power supply is 325 V. A 230 V RMS output from a generator delivers the same amount of power as a 230 V DC power supply across the same resistance. Similarly,  $I_{\text{RMS}}$  is the value of a DC current that generates the same power as an AC current through the same resistance:

$$I_{\text{RMS}} = \frac{I_{\text{peak}}}{\sqrt{2}}.$$

- The **peak-to-peak voltage**,  $V_{p-p}$ , is the difference recorded between the maximum and minimum voltages. In the case of a symmetrical AC voltage:

$$V_{p-p} = 2V_{\text{peak}}$$

Similarly:

$$I_{p-p} = 2I_{\text{peak}}$$

### Sample problem 7.4

A digital multimeter gives a measurement of 6.3 V for the RMS value of an AC voltage. A CRO is used to measure the peak-to-peak voltage. What value do you expect?

**Solution:**  $V_{\text{RMS}} = 6.3 \text{ V}$

$$\begin{aligned} V_{p-p} &= 2V_{\text{peak}} = 2 \times \sqrt{2} \times V_{\text{RMS}} \\ &= 2 \times \sqrt{2} \times 6.3 \text{ V} \\ &= 17.8 \text{ V} \\ &= 18 \text{ V} \end{aligned}$$

### Revision question 7.4

A toaster is rated at 230 V RMS and 1800 W. What are the values of the RMS and peak currents?

Vanes of a turbine at a coal plant



## Producing a greater EMF

The AC voltage produced by a generator has a substantial technological application because it is easy to make things spin. In hydroelectricity, electricity is produced when water falls under gravity through pipes and hits the vanes of a propeller connected to a generator. In coal and gas-fired turbines, the burning fuel heats up water to a high temperature and pressure to direct against the vanes of the turbine.

The emf that is produced by a generator has a frequency the same as the frequency of the rotation of a coil in a magnetic field.

Using the Faraday equation for average emf:

$$\text{emf} = \frac{-N\Delta(BA)}{\Delta t}$$



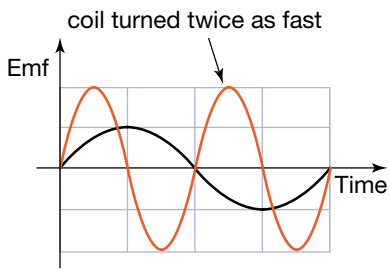

Doubling the frequency doubles the induced emf.

and ignoring the  $-$  sign (which relates to direction), we can deduce the following ways to produce a larger emf:

- increase the number of turns
- increase the strength of the magnetic field
- increase the area of each coil
- decrease the time for one turn (that is, increase the frequency of rotation).  
(Note that turning the coil twice as fast doubles both the induced emf and the frequency — that is, it halves the period.)

Other technological strategies can also increase the emf. These are described below.

- The pole ends of the magnet can be curved so that the coils are close to the magnets for more of the rotation.
- An iron core can be placed inside the coils to strengthen the magnetic field.
- The coils can be wound onto the iron core in grooves cut into the outer surface so that the iron core is as close as possible to the magnetic poles to increase the magnetic field.

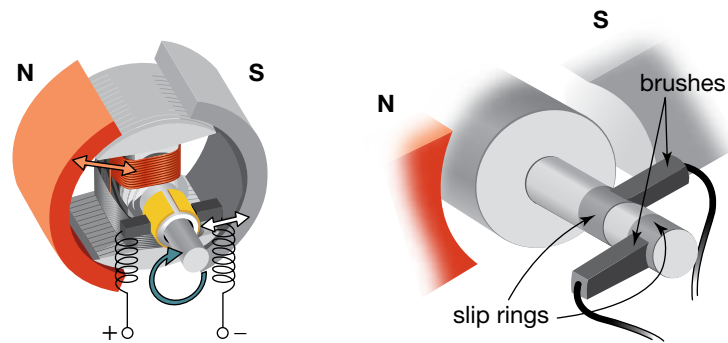

Improvements to the design of a DC motor and an alternator.

### study on

Unit 3

AOS 2

Topic 2

Concept 1

**Characteristics of the AC waveform**

Summary screen and practice questions

### study on

Unit 3

AOS 2

Topic 2

Concept 2

**RMS values and AC power**

Summary screen and practice questions

### study on

Unit 3

AOS 2

Topic 1

Concept 6

**Do more**

Producing AC in alternators

### study on

Unit 3

AOS 2

Topic 2

Concept 1

**See more**

Describing induced AC voltage



# Chapter review

## Summary

- A metal rod moving across a magnetic field experiences an induced voltage across its ends.
- The induced voltage across the ends of a moving conductor in a magnetic field will produce an electric current if the ends are connected by a wire outside the magnetic field.
- Magnetic flux is a measure of the amount of magnetic field passing through an area. It is measured in webers (Wb). Its magnitude is the product of the component of the magnetic field strength,  $B$ , that is perpendicular to the area and the area,  $A$ .
- An emf is induced in a loop if the magnetic flux passing through the loop changes. The emf induced in a single loop is given by  $\text{emf} = \frac{\Delta\Phi_B}{\Delta t}$ , where  $\Phi_B$  is the magnetic flux. The negative sign in the equation acknowledges Lenz's Law, which states that the induced current (and hence emf) is such that it creates a magnetic field that opposes the change in flux.
- The emf generated in  $N$  loops threaded by a magnetic flux,  $\Phi_B$ , is given by  $\text{emf} = \frac{-N\Delta\Phi_B}{\Delta t}$ .
- In an alternator, a coil rotates in a magnetic field to induce a sinusoidal voltage and therefore an alternating current. Slip rings are used at the end of the coil to allow the alternating current to flow in an external circuit.
- In a DC generator, the slip rings are replaced with a commutator to allow a direct current to flow in an external circuit.
- The voltage output of an AC generator can be described in terms of its amplitude, frequency and period. The amplitude of the voltage output is known as the peak voltage,  $V_{\text{peak}}$ . The peak-to-peak voltage,  $V_{\text{p-p}}$ , is the difference between the maximum and minimum voltages of the output.
- The RMS (root mean square) voltage,  $V_{\text{RMS}}$ , is the value of the constant DC voltage that would produce the same power as AC voltage across the same resistance. Similarly,  $I_{\text{RMS}}$  is the value of the constant direct current that would produce the same power as alternating current through the same resistance.
- The emf produced by a generator can be increased by increasing the number of turns in the coil, increasing the strength of the magnetic field, increasing the area of each coil or increasing the frequency of rotation of the coil.

## Questions

### Magnetic flux

1. What is the difference between magnetic flux and magnetic field strength?
2. Why did Faraday use coils with many turns of copper wire?
3. Calculate the maximum magnetic flux passing through:
  - (a) a single coil of area  $0.050 \text{ m}^2$  in a magnetic field of strength  $3.0 \text{ T}$
  - (b) a single coil of area  $4.5 \text{ cm}^2$  in a magnetic field of strength  $0.4 \text{ T}$
  - (c) a coil of 50 turns,  $12 \text{ cm}^2$  in area in a magnetic field of strength  $0.025 \text{ T}$ .
4. Draw a graph of the magnetic flux passing through a loop which is turning anticlockwise, from the position shown in the diagram below.

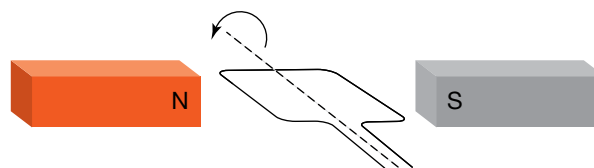

5. As the metal rod shown falls through the magnetic field, charge is separated and a voltage is established between the two ends of the rod. This requires energy. Where did the energy come from?

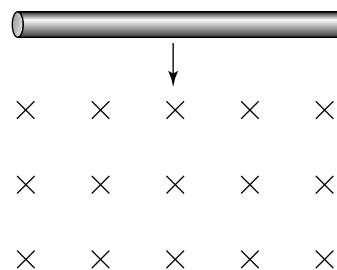

6. A magnet falling through a metal tube can achieve terminal velocity. Why?
7. (a) Explain what happens to the voltage between the ends of the rod in question 5 as the rod falls faster.  
(b) How does this process differ from charging a capacitor?

### Induced emf

8. The loop of wire shown on the next page is quickly withdrawn from the magnetic field. Which way does the current flow in the loop?

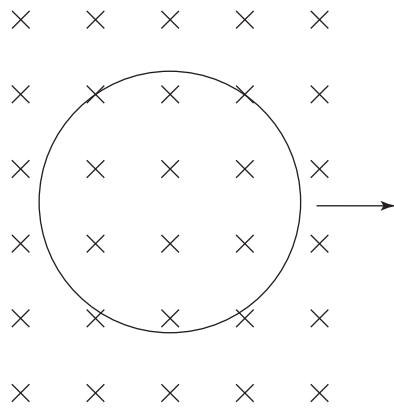

9. Two coils are placed one on top of the other with their centres in line.
- If a battery is switched on in the bottom coil, producing a clockwise current seen from above, what happens in the top coil?
  - Would the effect be different if the battery was connected to the top coil?
  - Would the effect be different if the battery was switched off?
10. Two coils are placed side by side on a page with their centres in line.
- If a battery is switched on in the left coil, producing a clockwise current (seen from the left), what happens in the right coil?
  - Would the effect be different if the current was anticlockwise?
11. The diagram below shows a confined uniform magnetic field coming out of the page with a wire coil in the plane of the page. Is there an induced current in the coil as it is moved in direction:
- A
  - B
  - C
  - D?

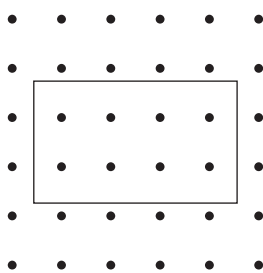

Answer key:

A -  $\rightarrow$

B -  $\uparrow$

C -  $\odot$  into page

D -  $\otimes$  out of page

12. Calculate the average induced emf in each of the following situations.
- A circular loop of wire of 5.0 cm radius is removed from a magnetic field of strength 0.40 T in a time of 0.2 s.

- The magnetic flux through a coil changes from 60 Wb to 35 Wb in 1.5 s.
  - The magnetic flux through a coil changes from 60 Wb to  $-35$  Wb in 2.5 s.
13. Calculate the average induced current in each of the following situations.
- A circular loop of wire, 10 cm long with a resistance  $0.4 \Omega$ , is removed from a magnetic field of strength 0.60 T in a time of 0.3 s.
  - The magnetic field strength perpendicular to a square loop, of side length 0.26 m and resistance  $2.5 \Omega$ , is increased from 0.2 T to 1.2 T in 0.5 s.
  - A stretched circular spring coil of 8 cm radius and resistance  $0.2 \Omega$  is threaded by a perpendicular magnetic field of strength 2.0 T. The coil shrinks back to a radius of 4 cm in 0.8 s.
14. A coil with an area of  $0.04 \text{ m}^2$  of 100 turns spins at a rate of 50 Hz in a magnetic field of strength 2.5 T.
- What is the average emf induced as the coil turns from parallel to the field to perpendicular to the field?
  - What is the average emf as the coil does one complete turn?
15. How can a motor operate as a DC generator?
16. (a) Use the relationship for the size of induced emf to show that the unit for the magnetic field, the tesla, can be written as volt  $\times$  second  $\times$  metre $^{-2}$ .
- (b) Now use Ohm's Law and the definition of electric current to show that the tesla can also be written as ohm  $\times$  coulomb  $\times$  metre $^{-2}$ .
- (c) Now use the definition of magnetic flux to show that the unit for magnetic flux, the weber, can be written as ohm  $\times$  coulomb.
17. An orbiting satellite has a small module tethered to it by a 5.0 km conducting cable. As the satellite and its module orbit Earth, they cut across Earth's magnetic field at right angles.
- If the pair are travelling at a speed of  $6000 \text{ m s}^{-1}$ , how far do they travel in 1.0 s?
  - What area does the conducting cable cross during the 1.0 s period?
  - If the strength of Earth's magnetic field at this distance is 0.1 mT, what is the size of the induced emf?
18. A bar magnet, with its north end down, is dropped through a horizontal wire loop.
- What is the direction of the induced current when the magnet is:
    - just above the loop
    - halfway through the loop
    - just below the loop?
  - Draw the graph of the induced current against time.

- (c) Where did the electrical energy of the induced current come from?
- (d) If the magnet falls from a very long distance above the loop to a very long distance below the loop, what is the overall change in magnetic flux through the loop? What does this imply about the area under the current-time graph?
- (e) If the magnet accelerates under gravity, how will the induced current in the coil compare in size and duration when the magnet is above and then below the loop?
19. How much charge, in coulombs, flows in a loop of wire of area  $1.6 \times 10^{-3} \text{ m}^2$  and resistance  $0.2 \Omega$  when it is totally withdrawn from a magnetic field of strength  $3.0 \text{ T}$ ?
20. A magnet passes through two loops, one wire and the other plastic. Compare the induced emfs and the induced currents of the two loops.
21. Lenz's Law is an illustration of the conservation of energy. Explain why the reverse of Lenz's Law (the direction of the induced current reinforces the change in magnetic flux) contravenes the law about the conservation of energy. Use the example of a north end of a magnet approaching a loop of conducting wire (as shown below).

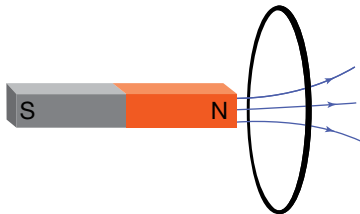

22. A DC motor has a coil rotating in a magnetic field. This rotation produces a 'back emf' that opposes the current from the battery.
- (a) How does the back emf vary with the speed of the motor?
- (b) How then would the current vary with the speed of the motor?

- (c) If the DC motor is used to lift masses, the speed of the motor is less for heavier masses. Why is there a risk that a heavy mass would burn out the motor?

23. Calculate the average emf in the axle of a car travelling at  $120 \text{ kph}$  if the vertical component of the Earth's magnetic field is  $40 \mu\text{T}$  and the length of the axle is  $1.5 \text{ m}$ . (*Hint: Calculate the area covered by the axle in one second.*)

### AC voltage and current

24. In the past electronic valves were powered by  $6.3 \text{ V}$  RMS AC. What was the maximum voltage received by the valve?
25. A CRO shows the following trace. The settings are:  
Y:  $10 \text{ mV}$  per division  
X:  $5 \text{ ms}$  per division.

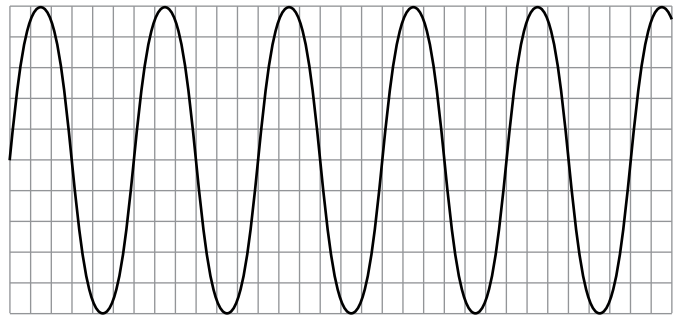

What are the:

- (a) period  
(b) frequency  
(c) peak voltage  
(d) peak-to-peak voltage  
(e) RMS voltage of this AC signal?
26. Some appliances are designed to run off either AC or batteries. The size of the batteries is equivalent to the peak of the AC voltage. If the appliance can run off  $9 \text{ V}$  DC, what RMS voltage would it also run off?



Transformers at a substation

**REMEMBER**

Before beginning this chapter, you should be able to:

- determine the amount of magnetic flux passing through an area
- determine the average induced voltage in a loop from the flux change and the time in which the change took place
- describe and determine the following properties of an AC voltage: frequency, period, amplitude, peak-to-peak voltage, peak-to-peak current, RMS voltage and RMS current
- describe the relationship between charge, current, voltage energy and power in electric circuits
- use the formulae  $Q = It$ ,  $E = VQ$ ,  $E = VIt$ ,  $P = VI$ ,  $V = IR$  and  $P = I^2R$ .

**KEY IDEAS**

After completing this chapter, you should be able to:

- explain the operation of a transformer in terms of electromagnetic induction
- determine the voltage and current using the number of turns in the primary and secondary coils, assuming the transformer is ideal
- determine transmission losses using  $V_{\text{drop}} = I_{\text{line}}R_{\text{line}}$  and  $P_{\text{loss}} = I_{\text{line}}^2R_{\text{line}}$
- explain the use of transformers in an electricity distribution system
- explain the advantage of AC power as a domestic power supply.

## Electric power

Electric power is generated for a purpose — to provide lighting in streets and homes, and to operate motors in domestic and industrial appliances. But electric power is often generated very far from where it is consumed. This problem *appears* to be simply overcome: make the connecting wires from the generator to the light or motor longer and longer, even stretching to hundreds of kilometres, and you have your basic transmission line.

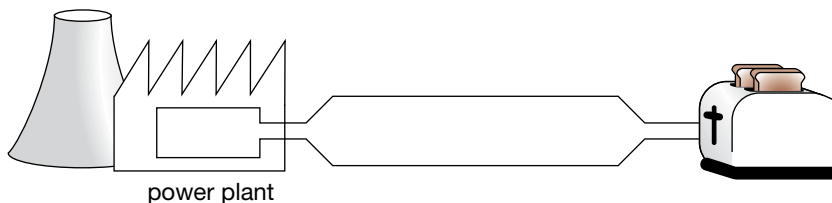

Why not just extend the wires from your toaster all the way back to the power plant generator?

This simple solution might work on the laboratory bench where the connecting wires are so short that their resistance is a very small fraction of the overall resistance in the circuit. However, when the wires extend over kilometres, their resistance becomes significant. So, too, does the power loss in them because of the  $I^2R$  heating effect of the current. In addition, so much of the supply voltage now drops along the wires, that the remaining voltage across the devices is insufficient for them to operate properly. However, this power loss and voltage drop can be reduced with the use of transformers.

### Sample problem 8.1

A 100 W light globe uses 100 J of energy every second when the voltage across it is 230 V.

- Calculate the current through the globe.
- Calculate the resistance of the globe for this current and voltage.
- If the globe was connected to a 230 V power supply by 2.0 m of copper wire, what would be the total resistance of the circuit? The wire has a resistance of  $0.022 \Omega \text{ m}^{-1}$ .
  - What would be the voltage across the globe?
- If the globe was connected by 100 km of copper wire, what would be the total resistance of the circuit?
  - What would be the voltage across the globe now?
- Comment on how the light globe would respond.

**Solution:** (a)  $P = 100 \text{ W}$ ,  $V = 230 \text{ V}$

$$I = \frac{P}{V}$$

$$I = 0.435 \text{ A} \quad (0.43 \text{ A to two significant figures})$$

The current through the globe is 0.43 A.

$$\begin{aligned} \text{(b)} \quad R &= \frac{V}{I} \\ &= \frac{230 \text{ V}}{0.435 \text{ A}} \end{aligned}$$

$$= 529 \Omega \quad (530 \Omega \text{ to two significant figures})$$

The resistance of the globe is 530  $\Omega$ .

$$\begin{aligned}
 \text{(c) (i) } R_{\text{total}} &= R_{\text{copper}} + R_{\text{globe}} \\
 &= (2.0 \text{ m} \times 0.022 \text{ } \Omega \text{ m}^{-1}) + 529 \text{ } \Omega \\
 &= 529 \text{ } \Omega \text{ to one decimal point} \\
 &\quad (530 \text{ } \Omega \text{ to two significant figures})
 \end{aligned}$$

The total resistance of the circuit is 530  $\Omega$ .

$$\begin{aligned}
 \text{(ii) } V &= \frac{R_{\text{globe}}}{R_{\text{total}} \times 230 \text{ V}} \\
 &= \frac{529 \text{ } \Omega}{529 \text{ } \Omega \times 230 \text{ V}} \\
 &= 230 \text{ V}
 \end{aligned}$$

The voltage across the globe is 230 V.

$$\begin{aligned}
 \text{(d) (i) } R_{\text{total}} &= R_{\text{copper}} + R_{\text{globe}} \\
 &= (100 \times 10^3 \text{ m} \times 0.022 \text{ } \Omega \text{ m}^{-1}) + 529 \text{ } \Omega \\
 &= 2729 \text{ } \Omega \text{ to the nearest whole number} \\
 &\quad (2700 \text{ } \Omega \text{ to two significant figures})
 \end{aligned}$$

The total resistance of the circuit is 2700  $\Omega$ .

$$\begin{aligned}
 \text{(ii) } V &= \frac{R_{\text{globe}}}{R_{\text{total}} \times 230 \text{ V}} \\
 &= \frac{529 \text{ } \Omega}{2729 \text{ } \Omega \times 230 \text{ V}} \\
 &= 45 \text{ V}
 \end{aligned}$$

The voltage across the globe is 45 V.

(e) The globe would not light up.

## Transformers

The transmission line transmits electrical energy from generator to appliance. The electrical energy is generated at a voltage set by the generator. The current drawn from the generator depends on the resistance in the appliances connected to the generator. Appliances are connected in parallel, so that they can all have the same voltage. Plugging in additional appliances is the same as adding extra resistances in parallel, with each appliance drawing its own current from the supply. The extra appliances in parallel reduce the total resistance in the circuit.

With more appliances connected, there is a larger current drawn from the generator and therefore greater energy supplied. The amount of energy supplied by the generator every second, or electrical power supplied, is equal to the product of the voltage supplied by the generator and the current drawn from the generator.

If the transmission lines are long, the energy wasted due to their resistance becomes a significant fraction of the energy supplied by the generator. If the same amount of energy every second (that is, the same power) can be sent along the lines but at a lower current, the energy loss will be less. In fact, since the power loss is given by  $I^2R$  (current<sup>2</sup>  $\times$  resistance of the lines), if the current through the lines is halved, the power loss is reduced by a quarter.

In 1831 Michael Faraday constructed a device to achieve this when he demonstrated that an electric current in one circuit had a magnetic effect that could produce an electric current in another circuit.

Faraday's **transformer** consisted of two sets of coils of wire wrapped around a ring of iron. One coil was connected to a battery by a switch, the other to a galvanometer, a sensitive current detector.

---

A **transformer** is a device in which two multi-turn coils are wound around an iron core. One coil acts as an input while the other acts as an output. The purpose of the transformer is to produce an output AC voltage that is different from the input AC voltage.

As with other examples of electromagnetic induction, the transformer works only when there is a change in magnetic flux in the coils and the connecting iron core.

With a battery connected to the primary coil, the secondary coil has a current only when the switch in the primary coil is either opening or closing. To produce a continuous current in the secondary coil, the current in the primary coil needs to be continually changing. The obvious candidate is AC current, but an AC generator was not developed until 1881 by Lucien Gaulard and John D. Gibbs.

A changing current,  $I$ , in the primary coil produces a changing magnetic field,  $B$ , in the iron core, which is propagated through the iron core to the secondary coil, where the changing magnetic field induces a changing emf in the secondary coil.

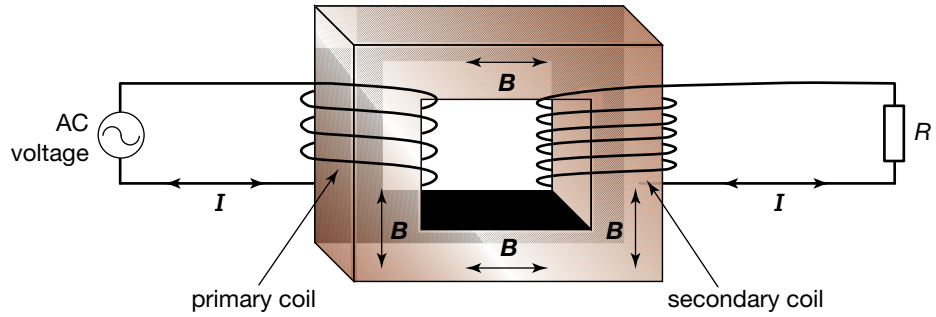

### eBookplus

**Weblink**  
Transformer applet

### study on

**Unit 3** Transformers –  
**AOS 2** how they work  
**Topic 3** Summary screen  
and practice  
questions  
**Concept 1**

### study on

**Unit 3** Transformers –  
**AOS 2** voltage and  
turns ratios  
**Topic 3** Summary screen  
and practice  
questions  
**Concept 2**

### study on

**Unit 3**   
**AOS 2**  
**Topic 3** Do more  
Transforming  
voltage and current  
**Concept 2**

## How does a transformer work?

Imagine an iron core shaped as a square. Around two sides are coils of wire. If an AC voltage is applied to the primary coil, an alternating magnetic field will be set up in the iron core. This alternating magnetic field will propagate through the iron core to the secondary coil. Here, the alternating magnetic field will induce an alternating voltage in this coil of the same frequency as the primary AC voltage.

An AC voltage supplied to the primary coil produces an AC voltage at the secondary coil, even though there is no electrical connection between the two coils. How do the sizes of the two voltages compare? In other words, how do the RMS voltages compare?

### Comparing voltages

When an AC voltage supply,  $V_{\text{prim}}$ , is connected to the primary coil, the current will be limited by the resistance in the coil — which will be proportional to the number of turns,  $N_{\text{prim}}$ , in the coil.

The iron core has constantly changing magnetic flux throughout. So, applying Faraday's Law:

to the primary coil gives

$$V_{\text{prim}} = N_{\text{prim}} \times \frac{\Delta\Phi_B}{\Delta t}$$

and to the secondary coil gives

$$V_{\text{sec}} = N_{\text{sec}} \times \frac{\Delta\Phi_B}{\Delta t}$$

Rearranging gives

$$\frac{\Delta\Phi_B}{\Delta t} = \frac{V_{\text{prim}}}{N_{\text{prim}}} = \frac{V_{\text{sec}}}{N_{\text{sec}}}$$

or

$$\frac{V_{\text{prim}}}{V_{\text{sec}}} = \frac{N_{\text{prim}}}{N_{\text{sec}}}$$



A **step-up transformer** produces an output (secondary) voltage that is greater than the input (primary) voltage.

A **step-down transformer** produces an output (secondary) voltage that is less than the input (primary) voltage.

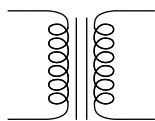

Circuit diagram symbol for transformer

This relationship means that two types of transformer can be built. One type, which produces a secondary voltage greater than the primary, is called a **step-up transformer**. In this, the number of secondary turns is greater than the number of primary turns.

The other type is a **step-down transformer**, which features more primary turns than secondary turns. It produces a smaller secondary voltage than the primary voltage. Both types are used in the distribution of electricity from generator to home, and also inside the home.

### AS A MATTER OF FACT

Low-voltage lighting is now quite common in instances where 230 V AC would present a safety risk (for example, Christmas tree lights or external garden lighting). In these cases, a step-down transformer converts the 230 V AC down to a safer 12 V AC.

If there is no energy loss as the energy is transferred from the primary to the secondary side, then the *power in* to the primary coil will equal the *power out* of the secondary coil. Since power = voltage  $\times$  current, this can be written as:

$$V_{\text{prim}} \times I_{\text{prim}} = V_{\text{sec}} \times I_{\text{sec}}$$

Using this relationship, the main design characteristics of any transformer can be determined.

### Sample problem 8.2

A step-down transformer is designed to convert 230 V AC to 12 V AC. If there are 190 turns in the primary coil, how many turns are in the secondary coil?

**Solution:**  $V_{\text{prim}} = 230 \text{ V}$ ,  $V_{\text{sec}} = 12 \text{ V}$ ,  $N_{\text{prim}} = 190 \text{ turns}$ ,  $N_{\text{sec}} = ?$

$$\frac{V_{\text{prim}}}{N_{\text{prim}}} = \frac{V_{\text{sec}}}{N_{\text{sec}}}$$

$$\frac{230 \text{ V}}{190 \text{ turns}} = \frac{12 \text{ V}}{N_{\text{sec}}}$$

$$N_{\text{sec}} = 12 \text{ V} \times \frac{190 \text{ turns}}{230 \text{ V}}$$

$$= 9.9, \text{ approximately } 10 \text{ turns}$$

### Revision question 8.1

A generator supplies 10 kW of power to a transformer at 1.0 kV. The current in the secondary coil is 0.50 A. What is the turns ratio of the transformer? Is it a step-up or a step-down transformer?

### study on

Unit 3

AOS 2

Topic 3

Concept 3

**Ideal transformers and electric power**

Summary screen and practice questions

### Ideal versus real

All transformers lose some energy in transferring electric power from the primary side to the secondary. This energy loss occurs in two areas. The first area is in the wires that make up the primary and secondary coils. This loss is called either *copper loss* (because the wires are usually copper), or *resistive* or  $I^2R$  loss. The loss is usually quite minor. If the transformer is being designed to take large currents, the wires on that side would be made thicker to take the high current and minimise the resistance.

An **eddy current** is an electric current induced in the iron core of a transformer. Eddy currents result in undesirable energy losses from the transformer.

The other area of energy loss in the transformer is in the iron core. The loss is due to induced currents in the iron core. These currents are called **eddy currents**, because they are like the swirls, or eddies, left in the water after a boat has gone by.

The changing magnetic flux in the iron core produces a changing voltage in each of the turns of the secondary coils. Iron is an electrical conductor, so it will behave in the same way as the turns of wire. A circular current will be induced in the iron in a plane at right angles to the direction of the changing magnetic flux.

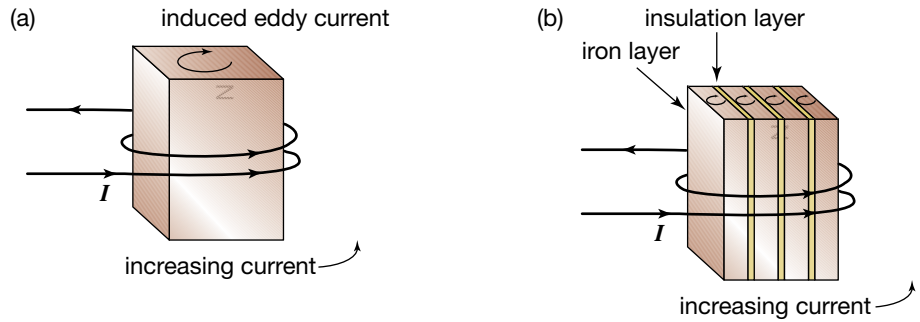

(a) An eddy current induced in an iron core by a changing magnetic field, and (b) putting the iron core into layers reduces the currents.

**study on**

Unit 3

AOS 2

Topic 3

Concept 3



See more

Electricity distribution system

If the iron core was one solid piece of iron, these induced eddy currents would be quite substantial. As iron has a low resistance, it would lead to large energy loss.

To minimise this loss, the iron core is constructed of layers of iron sandwiched between thin layers of insulation. These layers, called laminations, significantly reduce the energy loss. In practice, transformers used to transmit large quantities of energy are about 99% efficient.



Transmission lines and towers near Melbourne

# Power distribution and transmission line losses

## study on

Unit 3

AOS 2

Topic 3

Concept 4

**Transmission lines and power loss**

Summary screen and practice questions

## study on

Unit 3

AOS 2

Topic 3

Concept 4

**Do more**

Losing power

Development of the transformer meant that the AC voltage from the generator could be connected to a step-up transformer to increase the voltage and decrease the current, and so reduce energy loss in the transmission lines.

However, at the other end of the transmission line, the high voltage would be unsuitable, and possibly dangerous, for domestic appliances. So a step-down transformer is used to bring the voltage down to a safe level for home use.

In Victoria, electricity is generated at a variety of voltages. In Yallourn, the voltage is 20 000 V (20 kV). In Newport, the generating voltage is 24 000 V. From the various generators around Victoria, the voltage is stepped up to 500 kV to transmit the electrical energy over the long distances to Melbourne.

Because of the very high voltage, there is an increased risk of electrical discharge to the ground or the frame of the cable support, so tall towers are needed to hold the transmission cables high off the ground. Several porcelain discs are used to insulate the cables from the steel frame of the tower.

When the cables reach the outskirts of Melbourne, the high voltage is stepped down to 66 kV for distribution within the suburban area. In each suburb, the voltage is then further stepped down to 11 kV, either for delivery to yet another step-down transformer or to a neighbourhood power pole. There it is reduced to 230 V for connection to all the houses in the immediate neighbourhood.

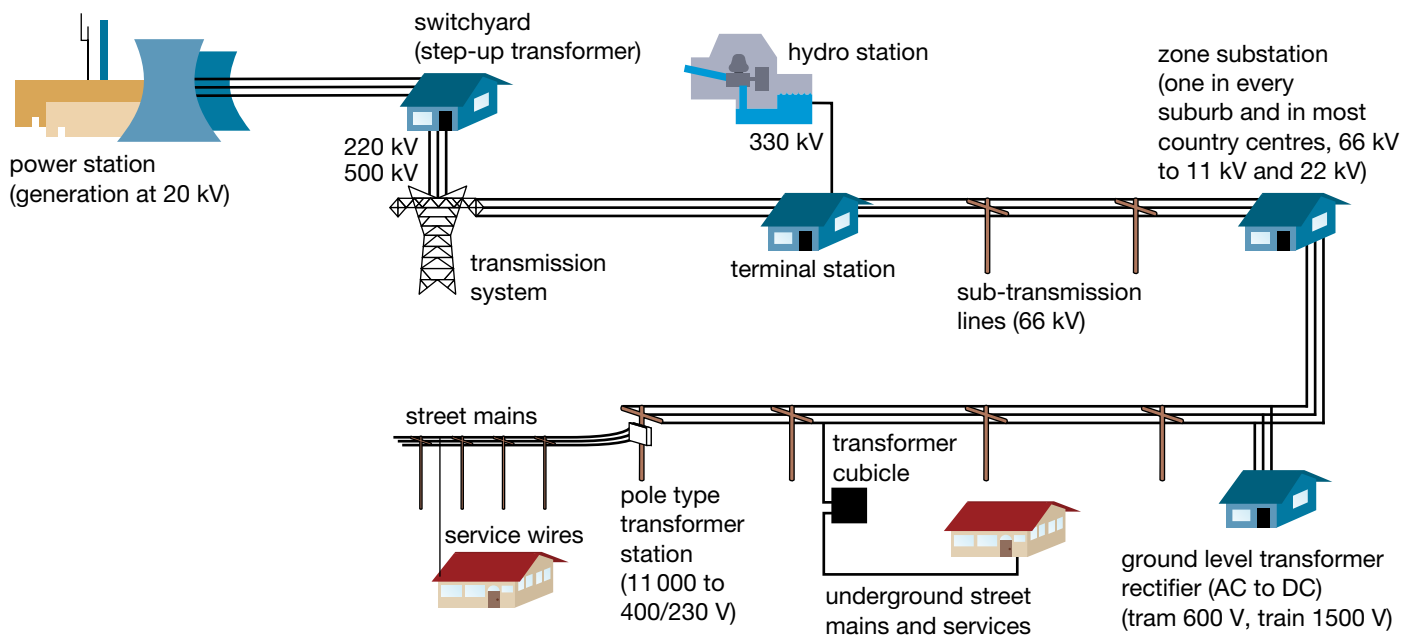

Victoria's power system — a representation

The high-voltage transmission line feeds several outer suburban terminal stations, each of which passes the current to several zone substations. These substations each connect to hundreds of pole transformers, which then connect to hundreds of homes. As the distribution system spreads further and further down to the domestic consumer, the current in the transmission line at each stage gets less and less.

## study on

Unit 3  
AOS 2  
Topic 3  
Concept 5

**Transformers and reducing power loss in electricity distribution**  
Summary screen and practice questions

**TABLE 8.1** Typical voltages in different sections of the transmission system

Ways to reduce resistance	Consequences
Major power tower or switchyard to terminal substation	220 kV, 330 kV or 500 kV
Terminal substation to zone substation	66 kV
Zone substation to pole-type transformer or underground transformer	22 kV
Pole-type transformer to house	230 V single phase, or 400 V for a three-phase supply

This means that the cables in each section need to be designed to handle the current in that section in a cost-effective way, maximising energy transfer while minimising the cost of doing so. To minimise energy loss, the resistance of the cable needs to be made as small as possible.

## PHYSICS IN FOCUS

### Transmission lines

In transmission lines, the current actually flows through the outer surface of the line to a depth of about 1 mm. This is called the skin effect. It happens because the voltage is applied to the surface of the transmission line and the effect of the voltage decreases exponentially with distance from the surface.

Transmission lines are bare, multi-layered, concentrically stranded aluminium cables with a core of steel or reinforced aluminium for tensile strength. The advantages of wires in a bundle over a single conductor of the same area are lower resistance to AC currents, lower radio interference and audible noise, and better cooling.

The smaller the sag in a transmission line, the greater will be the tension in the line. As the transmission lines cool, they contract, producing greater tension. High winds also increase the tension. All these factors may need to be considered when designing a transmission system.

The cost of building a transmission line is very nearly proportional to the input voltage, and to the length of the line. The cost to transmit each unit of power is proportional to the length and inversely proportional to the square root of the power. That is, if the power to be transmitted is quadrupled, it can be transmitted twice as far for the same unit cost. It is therefore uneconomical to transmit power over a long distance unless a large quantity of power is involved.

The cost of constructing a line underground rather than above ground ranges from eight times as much as (at 69 kV) to 20 times as much (at 500 kV). Underground cables are usually stranded copper, insulated with layers of oil-soaked paper tape. Superconductive cables may make this a more economical proposition.

Basslink uses subsea cables to transmit high-voltage DC between Victoria and Tasmania.

**TABLE 8.2** Ways to reduce resistance

Method	Effect
Make the wires fatter.	This increases the cost of the material in the wire and the cost of the pole to hold up the heavier wire.
Use a better conductor.	Metals differ in their electrical conductivity and in their economic value as a metal. Very good conductors such as gold and silver are too expensive to use as wires.

Imagine that 400 MW of power was available to be transmitted along a transmission line of  $4.0\ \Omega$ . How would the power losses due to the resistance of the transmission line vary with the voltage across the transmission line? The following table shows some typical values.

**TABLE 8.3** Transmission of 400 MW at different voltages

Transmission voltage	1000 kV	500 kV	220 kV	66 kV
Current $\left(I = \frac{P_{\text{tot}}}{V}\right)$	400 A	800 A	1800 A	6100 A
Power loss ( $P_{\text{loss}} = I^2 R$ )	640 kW	2.6 MW	13 MW	150 MW
Power loss (%)	0.2%	0.6%	3.3%	37%

### AS A MATTER OF FACT

Electric power was first transmitted in 1882 by Thomas Edison in New York and by St George Lane-Fox in London, both using a DC system for street lighting. The transmission was at low voltage with considerable transmission power line losses, and so limited to short distances.

Later that decade, George Westinghouse purchased patents for AC generators. His company also improved the design of transformers, and developed an AC-based transmission system. In 1886 these new developments allowed power to be transmitted over a distance of a kilometre, stepping up the voltage to 3000 V and then stepping it down to 500 V.

In the 1800s there was much debate on the relative efficiency of the AC and DC transmission systems as well as on their environmental effects. However, the superiority of the AC system was soon realised. By 1898 there was a 30 000 V 120 km line, and by 1934 the voltage was up to 287 000 V over 430 km. During World War II German scientists developed 380 000 V and overcame the effect of electrical discharge by using double cables.

During the 1960s transmission voltages reached 765 000 V. Future voltages are expected to be at 1 000 000 V.

### Sample problem 8.3

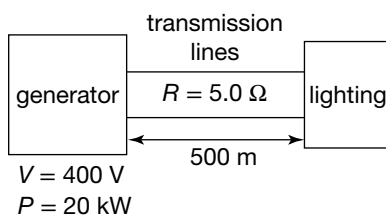

**Solution:**

- (a) A 20 kW, 400 V diesel generator supplies power for the 400 V lights on a film set at an outside location. The 500 m transmission cables have a resistance of  $5.0\ \Omega$ .
- What is the current in the cables?
  - What is the voltage drop across the transmission cables?
  - What is the power loss in the cables as a percentage of the power supplied by the generator?
  - What is the voltage supplied to the lighting?

- (i) Current in the cables = current coming from generator

For the generator:  $P = 20\ 000\ \text{W}$ ,  $V = 400\ \text{V}$ ,  $I = ?$

$$P = VI$$

$$20\ 000\ \text{W} = 400\ \text{V} \times I$$

$$I = \frac{20\ 000\ \text{W}}{400\ \text{V}}$$

$$= 50\ \text{A}$$

*Note:* Using  $V = IR$  with  $V = 400\ \text{V}$  and  $R = 5.0\ \Omega$  is incorrect because the 400 V is across both the cables *and* the load at the end.

(ii) For cables:  $I = 50 \text{ A}$ ,  $R = 5.0 \Omega$ ,  $V = ?$

$$\begin{aligned} V &= IR \\ &= 50 \text{ A} \times 5.0 \Omega \\ &= 250 \text{ V} \end{aligned}$$

(iii) For cables:  $I = 50 \text{ A}$ ,  $R = 5.0 \Omega$ ,  $P_{\text{loss}} = ?$

$$\begin{aligned} P_{\text{loss}} &= I^2 R \\ &= 50 \text{ A} \times 50 \text{ A} \times 5.0 \Omega \\ &= 12\,500 \text{ W} \end{aligned}$$

$$\begin{aligned} \text{As a percentage, } \% P_{\text{loss}} &= \frac{12\,500 \text{ W}}{20\,000 \text{ W}} \times \frac{100}{1} \\ &= 62.5\% \end{aligned}$$

*Note:* This answer could have been obtained by using  $P = VI$ , with  $V = 250 \text{ V}$  from solution 2; however, there is a risk that  $400 \text{ V}$  may be used by mistake, so it is better to use  $I^2 R$ .

(iv) Generator voltage = sum of voltages in circuit

$$\begin{aligned} V_{\text{gen}} &= 400 \text{ V}, V_{\text{cables}} = 250 \text{ V}, V_{\text{load}} = ? \\ 400 \text{ V} &= 250 \text{ V} + V_{\text{load}} \\ V_{\text{load}} &= 400 \text{ V} - 250 \text{ V} \\ &= 150 \text{ V} \end{aligned}$$

At this distance the voltage drop across the cables is too much to leave sufficient voltage to operate the lights at their designated voltage. Given the noise of the generators, they cannot be moved closer. Therefore, step-up and step-down transformers with turns ratios of 20 are used to reduce the power loss in the cables and increase the voltage at the lights.

(b) Repeat the calculations in part (a), but this time increase the generator voltage by a factor of 20 and, prior to connection to the lights, reduce the voltage by a factor of 20.

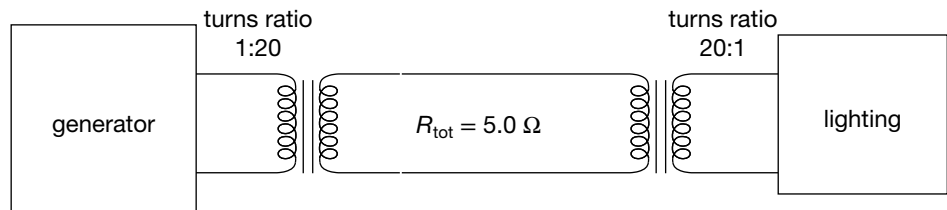

$$\begin{aligned} V &= 400 \text{ V} \\ P &= 20 \text{ kW} \end{aligned}$$

- (i) What is the current in the cables?
- (ii) What is the voltage drop across the transmission cables?
- (iii) What is the power loss in the cables as a percentage of the power supplied by the generator?
- (iv) What is the voltage supplied to the lighting?

**Solution:** (i) Current in cables = current coming from step-up transformer

$$\begin{aligned} V_{\text{sec}} &= 20 \times 400 \text{ V} \\ &= 8000 \text{ V} \end{aligned}$$

For an ideal transformer:  $P_{\text{prim}} = 20\,000 \text{ W}$ ,  $I_{\text{sec}} = ?$

$$\begin{aligned} P_{\text{prim}} &= P_{\text{sec}} = V_{\text{sec}} I_{\text{sec}} \\ 20\,000 \text{ W} &= 8000 \text{ V} \times I_{\text{sec}} \end{aligned}$$

$$I_{\text{sec}} = \frac{20\,000\text{ W}}{8000\text{ V}} = 2.5\text{ A}$$

(ii) For cables:  $I = 2.5\text{ A}$ ,  $R = 5.0\ \Omega$ ,  $V = ?$

$$\begin{aligned} V &= IR \\ &= 2.5\text{ A} \times 5.0\ \Omega \\ &= 12.5\text{ V} \end{aligned}$$

(iii) For cables:  $I = 2.5\text{ A}$ ,  $R = 5.0\ \Omega$ ,  $P_{\text{loss}} = ?$

$$\begin{aligned} P_{\text{loss}} &= I^2 R \\ &= 2.5\text{ A} \times 2.5\text{ A} \times 5.0\ \Omega \\ &= 31.25\text{ W} \end{aligned}$$

$$\begin{aligned} \text{As a percentage, } \% P_{\text{loss}} &= \frac{31.25\text{ W}}{20\,000\text{ W}} \times \frac{100}{1} \\ &= 0.16\%. \end{aligned}$$

This is  $\left(\frac{1}{20}\right)^2$  or  $\frac{1}{400}$  of the original power loss! This is an impressive reduction.

(iv) Voltage supplied to step-down transformer =  $8000\text{ V} - 12.5\text{ V} = 7988\text{ V}$

Voltage supplied to lighting:

$$\begin{aligned} V_{\text{sec}} &= 7988\text{ V} \times \frac{1}{20} \\ &= 400\text{ V} \end{aligned}$$

Actually, the two-figure accuracy of the turns ratio means that the voltage 7988 V should be rounded to 8000 V.

### Revision question 8.2

A remote community uses a 50 kW, 250 V generator to supply power to its hospital. The power is delivered by a 100-metre cable with total resistance of 0.20  $\Omega$ .

- (a) Answer the questions in part (a) of sample problem 8.3 as they apply to this question.  
 (b) Transformers with a turns ratio of 10:1 are installed. Repeat (a) with this new ratio.

## Using Ohm's Law wisely

The relationship  $V = IR$  (Ohm's Law) is very useful. It can be applied in many situations in the one problem. This usefulness can lead to error if Ohm's Law is not applied wisely. The errors occur when students assume that having calculated a value for  $V$ , that value can be used every time  $V = IR$  is used.

Rather,  $V = IR$  should be remembered as:

Voltage across a section = current through the section  
 $\times$  resistance of that section.

So, in transmission line problems, the voltage across the output of the generator is different from the voltage across the transmission lines, which is different, in turn, from the voltage across the load at the end of the lines.

A well-labelled diagram can help avoid this confusion. Imagine the generator as a battery and the two lines and the load as three separate resistors sharing the voltage from the battery.

In any electric circuit the total resistance determines how much current is drawn from the power supply. If there are transformers in the circuit, this statement is still true, but there are different currents and voltages on each side of the transformer.

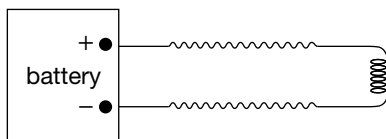
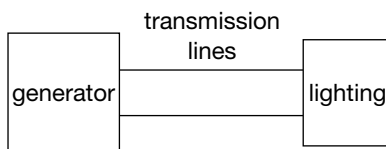

Circuit diagram and battery circuit

As more appliances are turned on, there is a larger secondary current, which causes a larger primary current to be drawn from the power supply. This means the secondary current drives the primary current. When all the appliances are turned off, there is no secondary current and, so, no primary current.

However, the primary voltage determines the secondary voltage through the ratio of turns in the transformer.

With more appliances turned on, the current in the transmission lines between the transformers increases. The increased voltage drop across these lines means that there will be slightly less voltage across the primary turns of the step-down transformer. This will result in a slight drop in the voltage for each of the appliances.

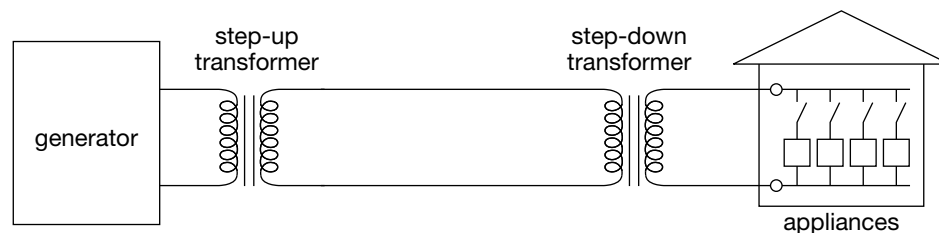

An electric circuit with step-up and step-down transformers

## REMEMBER THIS

Electric power is normally discussed in terms of watts or megawatts — for example, when comparing electrical generators or deciding between vacuum cleaners. However, the generator supplies *energy*, the cleaner consumes *energy*, and it is ultimately we who pay for *energy*. The **power rating**, or wattage, of an electrical appliance indicates the rate at which it uses electricity. The longer it is on, the more energy is used and the more it costs. By definition:

$$1 \text{ watt} = 1 \text{ joule per second, so}$$

$$1 \text{ joule} = 1 \text{ watt} \times 1 \text{ second, or } 1 \text{ watt second.}$$

As 1 watt second is equivalent to 1 joule, then

$$1000 \text{ watt seconds} = 1000 \text{ J, or}$$

$$1 \text{ kilowatt second} = 1 \text{ kJ.}$$

If a 1 kW heater was on for 1 s, it would use 1 kilowatt second or 1 kilojoule of electrical energy. If it was on for 60 seconds, it would use 60 kilowatt seconds or 60 kilojoules.

The common unit for energy supply and consumption in electricity is the kilowatt hour, which is the amount of energy consumed, for example, by a one-kilowatt heater for one hour. This unit is abbreviated to kWh (e.g. 60 kWh).

### Conversion from kilowatt hour to joules:

$$1 \text{ kWh} = 60 \times 60 \text{ kilowatt seconds}$$

$$= 3600 \text{ kilowatt seconds}$$

$$= 3\,600\,000 \text{ watt seconds}$$

$$= 3.6 \times 10^6 \text{ joules}$$

$$= 3.6 \text{ megajoules.}$$

The **power rating**, or wattage, of an electrical appliance indicates the rate at which it uses electrical energy.





# Chapter review

## Summary

- A transformer is a device in which two multiple-turn coils are wound around an iron core. One coil, the primary coil, acts as an input; the other, the secondary coil, acts as an output.
- In a transformer, the iron core transfers the changing magnetic flux produced by an AC current in the primary coil to the secondary coil. The changing magnetic flux in the secondary coil induces an alternating voltage, producing an alternating current.
- The purpose of the transformer is to produce an output AC voltage that is different from the input AC voltage.
- A step-up transformer produces an output (secondary) voltage that is greater than the input (primary) voltage. A step-down transformer produces an output (secondary) voltage that is less than the input (primary) voltage.
- The relationship between the primary voltage and secondary voltage of a transformer is given by the equation:

$$\frac{V_{\text{prim}}}{V_{\text{sec}}} = \frac{N_{\text{prim}}}{N_{\text{sec}}}$$

- An ideal transformer does not lose energy. The power output of the secondary coil is equal to the power input of the primary coil. Thus

$$V_{\text{prim}}I_{\text{prim}} = V_{\text{sec}}I_{\text{sec}}$$

- Real transformers lose energy in transferring electric power from the primary coil to the secondary coil. Some is lost in the wires that make up the coils. Some energy is lost due to induced currents (eddy currents) in the iron core.
- When AC electric power is transmitted over long distances, some energy is lost due to the resistance of the transmission lines. The rate at which energy is lost can be calculated using the formula  $P = I^2R$ .
- The power losses in long-distance transmission lines can be reduced by using step-up transformers to increase the transmission voltage, thereby reducing the transmission current. Step-down transformers are then used to reduce the voltage supplied to homes and industrial customers.

## Questions

### Transformers

1. An ideal transformer has 100 turns in the primary coil and 2000 turns in the secondary coil. If the primary coil was connected to 230 V AC, what would be the voltage across the secondary coil?
2. A transformer has 300 turns in the primary coil and six turns in the secondary coil.
  - (a) If 230 V AC is connected to the primary coil, what will be the voltage across the secondary coil?
  - (b) If the secondary voltage is 9.0 V AC, what is the voltage across the primary coil?
3. Christmas tree lights need a transformer to convert the 230 V AC to 12 V AC.
  - (a) If there are 50 coils on the 12 V secondary coil, how many turns are there in the primary coil?
  - (b) If there are 20 globes connected in parallel to the secondary coil, each of 12 V and 5 W, what is the current in the secondary coil?
  - (c) What is the current in the primary coil, assuming the transformer is ideal?
4. Explain why a transformer does not work with a constant DC input voltage.
5. Why is the core of transformers made of an alloy of iron that is easy to magnetise?
6. A transformer is used to change 10 000 V to 230 V. There are 2000 turns in the primary coil.
  - (a) What type of transformer is this?
  - (b) How many turns are there in the secondary coil?
7. An ideal transformer has 400 turns in the primary coil and 900 turns in the secondary coil. The primary voltage is 60 V and the current in the secondary coil is 0.30 A.
  - (a) What is the voltage across the secondary turns?
  - (b) What is the power delivered by the secondary coils?
  - (c) What is the current in the primary coil?

### Transmission lines

8. An isolated film set uses a 50 kW generator to produce electricity for lighting and other purposes at 250 V RMS. The generator is connected to lights about 100 m away by transmission cables with a combined resistance of 0.3  $\Omega$ .
  - (a) When the generator is operating at full capacity, what current does it supply?
  - (b) What is the power loss in the transmission cables?
  - (c) What is the total drop in voltage across the two cables connected by the generator?
  - (d) What is the voltage supplied to the lights?
  - (e) Two transformers with a turns ratio of 20 are used to first step up the voltage from the generator to the cables, and then to step it down from the cables to the lights. Using this new information, answer (b) to (d) above again.

9. The appliances in a house would, if all turned on and connected to a power supply of 230 V, draw a current of 40 A.

(a) What is the effective resistance of the appliances in the house, when they are all turned on?

However, the house is some distance from the power lines and the connecting cables have a resistance of  $0.20\ \Omega$ .

- (b) What is the total resistance of the circuit connected to the power lines?  
(c) If the voltage at the power lines is 230 V AC, what is the voltage at the house?  
(d) A 20 kW workshop which operates off the 230 V supply is installed in the garage in parallel to the house. Answer parts (b) and (c) again for the new situation.

The owners now decide to install a step-up transformer and a step-down transformer, each with a turns ratio of 10:1, at either end of the transmission lines.

- (e) If the system draws 120 A from the grid at 230 V, will the voltage at the house and the garage be within 1% of 230 V for the appliances to work properly?  
(f) At night the workshop is turned off. Will the voltage at the house increase, decrease or remain unchanged? Give reasons.
10. A generator at a power station produces 220 MW at 23 kV. The voltage is then stepped up to 330 kV.

The power passes along transmission lines with a total resistance of  $0.40\ \Omega$ .

- (a) What is the current in the transmission lines?  
(b) What is the power loss in transmission lines?  
(c) What is the voltage drop across them?  
(d) What voltage and power is available to the step-down transformer located at the end of the lines?

11. The maximum electrical power the generator at a power station can deliver is 500 MW at a voltage of 40 kV. This power is to supply the electricity needs of a distant city. Transmission lines connecting the station to the city have a total resistance of  $0.8\ \Omega$ . At the city, the transmission lines are connected to a series of step-down transformers that reduce the voltage to 230 V. The city wants a two-step evaluation of the transmission system.

- (a) What percentage of the power delivered by the power station is lost in the transmission lines? The power loss can be reduced by stepping up the voltage at the generator with a transformer. At the substations on the city's outskirts, the voltage is stepped down. The voltage could be stepped up to 400 kV with a transformer with a turns ratio of 10:1. The same transmission lines could be used, but they would need to be raised higher off the ground and be better insulated at each pole.  
(b) What would be the effect on the power loss in the transmission lines?

# UNIT 4

## AREA OF STUDY 1

**CHAPTER 9** Mechanical waves

**CHAPTER 10** Light as a wave

## AREA OF STUDY 2

**CHAPTER 11** The photoelectric effect

**CHAPTER 12** Matter – particles and waves

## AREA OF STUDY 3

**CHAPTER 13** Practical investigations

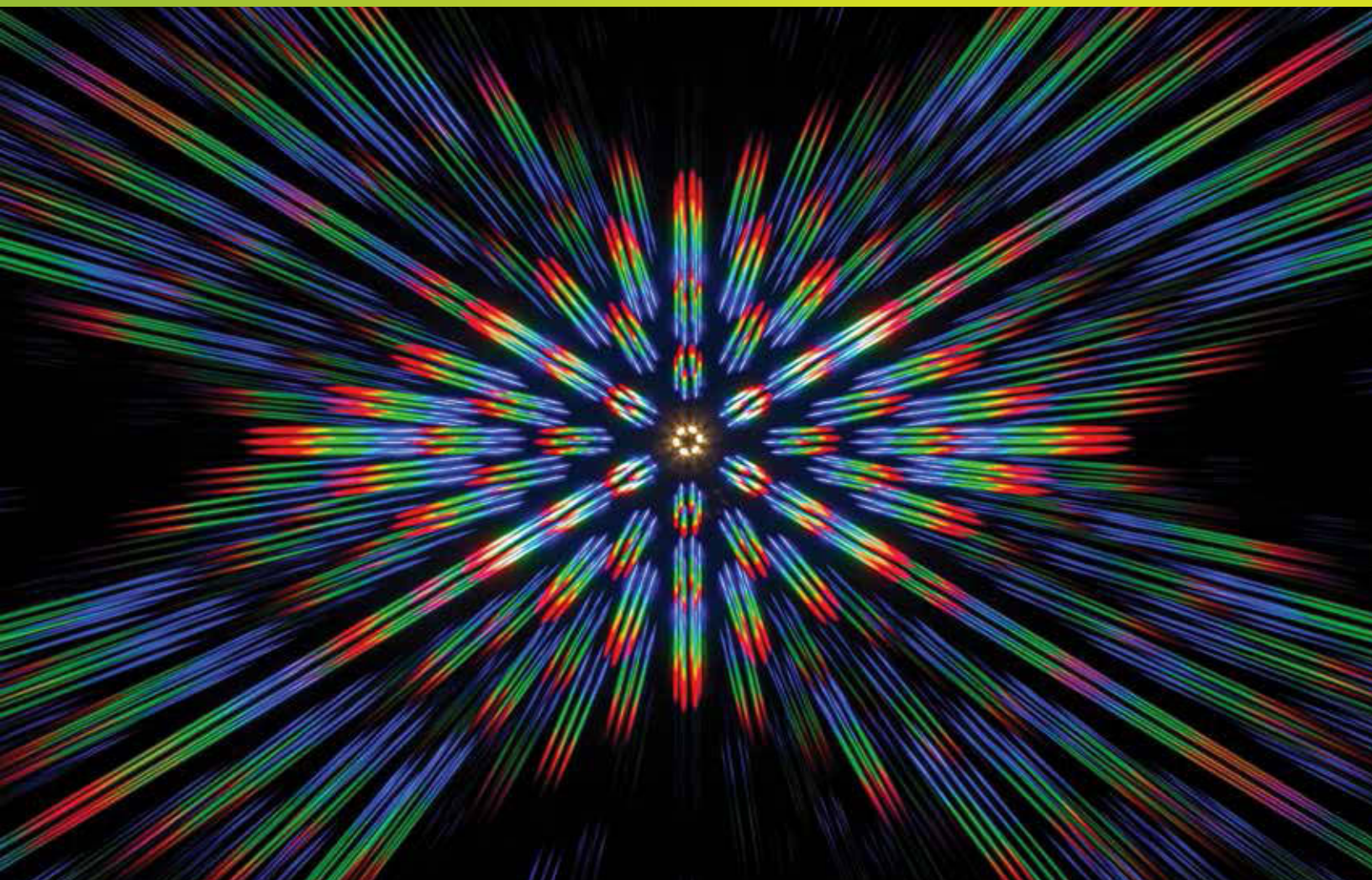

## KEY IDEAS

After completing this chapter, you should be able to:

- explain waves as the transmission of energy without the net transfer of matter through a medium
- identify features of waves, including the amplitude, wavelength, period and frequency
- identify transverse and longitudinal waves:
  - describe sound as a longitudinal pressure wave
  - describe light as a transverse wave
  - recognise visible light as part of the electromagnetic spectrum
  - use ray diagrams to show how light is reflected from smooth surfaces
  - appreciate that light travels in straight lines
  - apply a wave model to the behaviour of light and the rest of the electromagnetic spectrum
- use  $v = f\lambda = \frac{\lambda}{T}$  to calculate the wavelength, frequency, period and speed of waves
- investigate and analyse constructive and destructive interference from two sources theoretically and practically
- use the expressions  $n\lambda$  and  $(n - \frac{1}{2})\lambda$
- explain the Doppler effect
- explain resonance as the vibration of an object caused when a forced oscillation matches the object's natural frequency of vibration
- explain the formation of a standing wave as the superposition of a travelling wave and its reflection
- investigate standing waves in strings fixed at one or both ends
- explain diffraction as the spread of various frequencies (and wavelengths) of waves as they pass around objects or through gaps in barriers
- explain the diffraction patterns formed when waves pass through gaps of different widths or around obstacles, including the qualitative effect of changing the  $\frac{w}{\lambda}$  ratio for gaps or the wavelength of the wave passing an obstacle.

The study of waves reveals many important concepts in physics.

# Light and its properties

Sight is the sense by which humans and most other mammals get most of their information about the world. This sense responds to light. Questions about light naturally arise. Where does light come from? What can it do? How can its properties be explained?

Some obvious observations of light are:

- Sources of light are needed to see.
- Light travels very fast.
- Light produces shadows.

## Sources of light

When we experience darkness at night or in an enclosed room, we know that a source of light, such as the Sun or a lamp, is needed to light up the darkness. Once a lamp is turned on, we can see features in the room because the light from the lamp shines on them and is then reflected into our eyes.

This means that objects can be classified into two groups. Objects seen because they give off their own light are called **luminous** objects; those seen because they reflect light are called non-luminous objects. The Sun, torches and candles are luminous objects. Tables, chairs, cats and dogs are non-luminous objects.

Some luminous objects produce light because they are hot. The Sun is one example. The higher the temperature, the brighter the light, and the colour also changes. These objects are called **incandescent**.

---

Objects that give off their own light are described as **luminous**.

---

Luminous objects that produce light as a result of being hot are described as **incandescent**.



The Pleiades open star cluster in the constellation Taurus. All stars are incandescent sources of light.

Other objects are cold and produce light in another way. This involves changes in the energy of electrons in the material brought about by either chemical or electrical processes.

**Digital docs**Investigation 9.1  
Luminous or not?**doc-18545**Investigation 9.2  
Luminosity and temperature**doc-18546**

## Speed of light

The gap we experience between seeing lightning and hearing thunder shows that sound travels relatively slowly. Light seems to travel so fast that to our experience its speed seems infinite; that is, we seem to observe events at the instant they happen.

Galileo Galilei (1564–1642) was not convinced of this. He attempted to determine the speed of light by measuring the time delay between the flash of his lamp to an assistant on a distant mountain and the return flash from his assistant's lamp. No detectable delay was observed and Galileo concluded that the speed of light was very high. A longer distance was needed.



Galileo used this method to measure the speed of light. He attempted to time, with his pulse, the delay between uncovering his lantern and seeing the light from his partner's lantern, which his partner uncovered at the moment when he saw the light from Galileo's lantern.

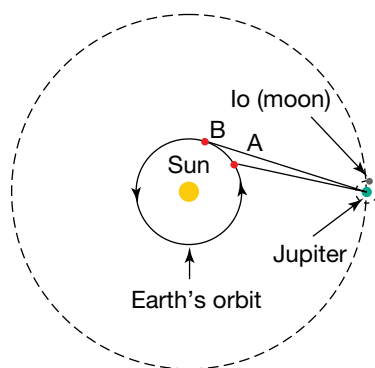

The time, as seen from the Earth, for Jupiter's moon, Io, to orbit Jupiter increases as the Earth moves from A to B. (The diagram is not to scale.)

Olaus Roemer was a Danish astronomer born two years after Galileo's death. He observed that the time between eclipses of Jupiter's moons by Jupiter decreased as the Earth moved closer to Jupiter and increased as the Earth moved away. Roemer reasoned that this was because the distance the light travelled from Jupiter to Earth became greater as the Earth's orbit took it further from Jupiter (see the left figure on page 201). Roemer used this time and the known diameter of the Earth's orbit about the Sun to estimate the speed of light. The value he obtained was  $2.7 \times 10^8 \text{ m s}^{-1}$ .

Eventually, in the nineteenth century, with stronger light sources and more precise timing devices, Galileo's method could be used, but the assistant was replaced by a mirror. The values obtained then were about  $3.0 \times 10^8 \text{ m s}^{-1}$ .

Early in the twentieth century, the American scientist Albert A. Michelson (1852–1931) used a rapidly rotating eight-sided mirror (see the right figure on page 201). The light was reflected to a distant mirror about 35 kilometres away, then reflected back to the rotating mirror. For some particular rotation rates, this light is reflected by one of the sides of the rotating mirror directly to the observer. The rotation rate can be used to calculate the speed of light.

The value Michelson obtained was  $2.997\,96 \times 10^8 \text{ m s}^{-1}$ . He actually measured the distance of 35 km to an accuracy of 2.5 cm. The speed of light is currently measured at  $2.997\,924\,58 \times 10^8 \text{ m s}^{-1}$ . It is rounded off to  $300\,000 \text{ km s}^{-1}$  for calculation purposes.

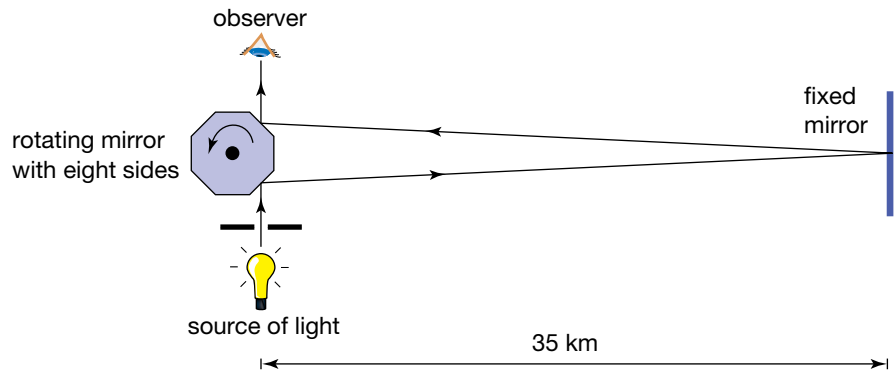

Light from the source reflects off one of the sides of the rotating mirror towards a mirror 35 kilometres away. The returning beam hits the rotating mirror. If one of the sides of the mirror is in the right position, the light enters the eyepiece and can be seen by the observer. By measuring the speed of rotation when the beam enters the eyepiece, the speed of light can be calculated.

### Sample problem 9.1

How long does light take to travel from the Sun to the Earth?

**Solution:** speed of light =  $3.00 \times 10^8 \text{ m s}^{-1}$   
distance from Sun to Earth =  $1.49 \times 10^{11} \text{ m}$

$$\text{speed} = \frac{\text{distance travelled}}{\text{time taken}}$$

$$\Rightarrow \text{time taken} = \frac{\text{distance travelled}}{\text{speed}}$$

$$\text{time} = \frac{1.49 \times 10^{11} \text{ m}}{3.00 \times 10^8 \text{ m s}^{-1}}$$

$$= 0.497 \times 10^3 \text{ s}$$

$$= 497 \text{ s}$$

$$= 8 \text{ minutes } 17 \text{ seconds.}$$

### Sample problem 9.2

How far does light travel in one year (one light-year)?

**Solution:** distance travelled = speed  $\times$  time taken

$$\text{distance} = 3.00 \times 10^8 \text{ m s}^{-1} \times (365.25 \times 24 \times 60 \times 60) \text{ s}$$

$$= 9.47 \times 10^{15} \text{ m}$$

$$= 9.47 \times 10^{12} \text{ km.}$$

## Shadows

The bright Sun produces sharp shadows on the ground. The shape of the shadow is the same shape as the object blocking the light. This could happen only if light travels in a straight line.

The straight rays passing the edge of a bird leave a sharp shadow on the ground.



## Ray model

The need for sources of light, the great speed of light and the existence of sharp shadows can be described by a ray model. The model assumes that light travels in a straight line path called a light **ray**. A light ray can be considered as an infinitely narrow beam of light and can be represented as a straight line (see the figure below).

A **ray** of light is a very narrow pencil-like beam of light.

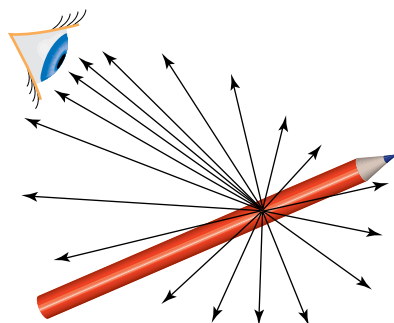

Light rays leave a point on this pencil and travel in straight lines in all directions. The pencil is seen because of the 'bundle' of rays that enter the eye.

## Plane mirror reflection

When you look at yourself in a plane mirror, some of the light rays from your nose, for example, travel in the direction of the mirror and reflect off in the direction of your eye. What is happening at the surface of the mirror to produce such a perfect image?

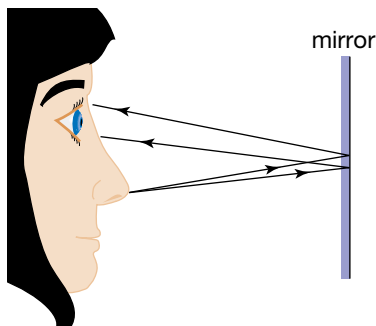

Light rays from the tip of the nose reflect off the mirror and enter the eye.



The **angle of incidence** is the angle between an incident ray and the normal.

The **angle of reflection** is the angle between a reflected ray and the normal.

To investigate the reflection of light, the angles made by the rays need to be measured. Measurements of these angles show that, like a ball bouncing off a flat wall, the **angle of incidence** equals the **angle of reflection**.

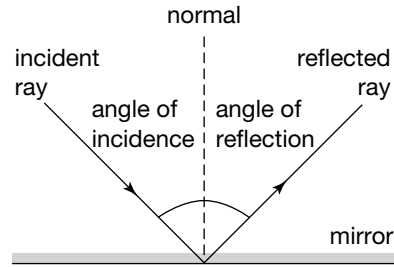

The ray approaching the mirror is called the incident ray. The ray leaving the mirror is called the reflected ray. The normal is a line at right angles to the mirror. The angles are measured between each ray and the normal. When the path of a light ray is traced, it is found that the angle of incidence always equals the angle of reflection.

The **normal** is a line that is perpendicular to a surface or a boundary between two surfaces.

The other seemingly trivial conclusion that can be drawn from the investigation is that the incident ray, the **normal** and the reflected ray all lie in the same plane.

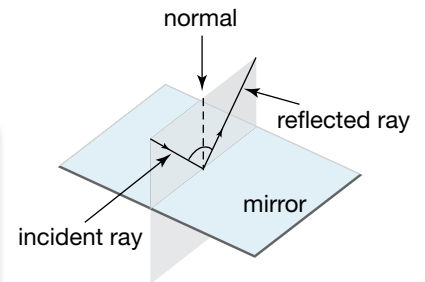

The incident ray, the 'normal' to the surface of the mirror and the reflected ray all lie in the same plane, which is at right angles to the plane of the mirror.

**Regular reflection**, also referred to as **specular reflection**, is reflection from a smooth surface.

**Diffuse reflection** is reflection from a rough or irregular surface.

## Regular and diffuse reflection

Reflection from a smooth surface is called **regular** or **specular reflection**. But what happens with an ordinary surface, such as this page? A page is not smooth like a mirror. At the microscopic level, there are 'hills and valleys.' As the light rays come down into these hills and valleys, they still reflect with the two angles the same but, because the surface is irregular, the reflected rays emerge in all directions. This is called **diffuse reflection**. Light rays from diffuse reflections — from the ground, trees and other objects — enter the eye and enable the brain to make sense of the world.

This is diffuse reflection. Each of the incoming parallel rays meets the irregular surface at a different angle of incidence. The reflected rays will therefore go off in different directions, enabling observers in all directions to receive light from the surface; in other words, to see the surface.

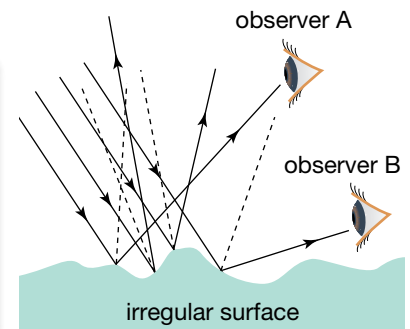



(a) White light



(b) Red light



(c) Blue light

Changing the colour of the light on these flowers from white to red to blue changes our perception of their colour.

## What is colour?

Colours are an important part of our language and our environment. Colours can be peaceful to the eye or very stimulating. We use colours in our language to convey feelings and emotions (for example, *fiery red*, *warm orange* and *icy blue*).

At first, colour may seem to be a defining part of an object, like size, shape and texture. For example, we say *green leaves*, *red earth* and *blue eyes*. It is only when experiments are done with light that we realise that the colour or appearance of an object changes with the light that is shining on it.

But what about rainbows? And the blue sky? Here we seem to have colour, pure colour, separate from any solid object. So what really is colour? It is both a property of light and an aspect of human perception. You will learn more about the physics of colour later in this chapter and in chapter 10.

## Waves — energy transfer without matter transfer

A **wave** is a disturbance that travels through a medium from the source to the detector without any movement of matter. Waves therefore transfer energy without any net movement of particles. **Periodic waves** are disturbances that repeat themselves at regular intervals. Periodic waves propagate by the disturbance in part of a medium being passed on to its neighbours. In this way the disturbance travels, but the medium stays where it is.

Looking at the examples in the table below, two different types of waves can be identified. For the pulse on the rope and the ripples on the water surface, the disturbance is at right angles to the direction the wave is travelling. These types of waves are called **transverse waves**.

In the examples of the sound wave travelling through air and the compression moving along the spring, the disturbance is parallel to the direction the wave is travelling. These types of waves are called **longitudinal waves**.

**TABLE 9.1** Some examples of waves

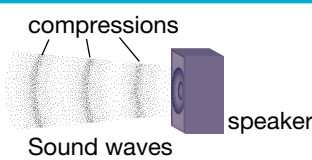
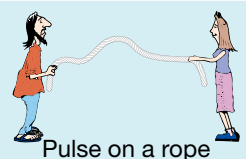
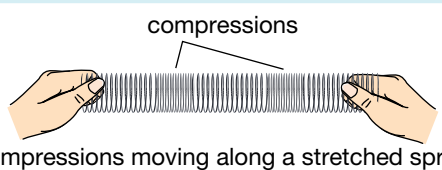
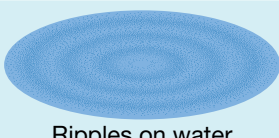
Wave	Source	Medium	Detector	Disturbance
Sound	Push/pull of a loudspeaker 	Air	Ear	Increase and decrease in air pressure
Rope	Upward flick of hand 	Rope	Person at other end	Section of rope is lifted and falls back
Stretched spring	Push of hand 	Coils in the spring	Person at other end	Bunching of coils
Water	Dropped stone 	Water	Bobbing cork	Water surface is lifted and drops back

A **wave** is a transfer of energy through a medium without any net movement of matter.

**Periodic waves** are disturbances that repeat themselves at regular intervals.

**Transverse waves** are those for which the disturbance is at right angles to the direction of propagation.

**Longitudinal waves** are those for which the disturbance is parallel to the direction of propagation.

The **frequency** of a periodic wave is the number of times that it repeats itself every second.

The **period** of a periodic wave is the time it takes a source to produce a complete wave.

The **amplitude** of a wave is the size of the maximum disturbance of the medium from its normal state.

The **wavelength** is the distance between successive corresponding parts of a periodic wave.

## Properties of waves

The **frequency** of a periodic wave is the number of times that it repeats itself every second. Frequency is measured in hertz (Hz) and  $1 \text{ Hz} = 1 \text{ s}^{-1}$ . Frequency can be represented by the symbol  $f$ .

The **period** of a periodic wave is the time it takes a source to produce a complete wave. This is the same as the time taken for a complete wave to pass a given point. The period is measured in seconds and is represented by the symbol  $T$ .

The period of a wave is the reciprocal of its frequency. For example, if five complete waves pass every second, i.e.  $f = 5.0 \text{ Hz}$ , then the period (the time for one complete wavelength to pass) is  $\frac{1}{5.0} = 0.2$  seconds. In other words,  $f = \frac{1}{T}$ . It follows that  $T = \frac{1}{f}$ .

The **amplitude** of a wave is the size of the maximum disturbance of the medium from its normal state. The units of amplitude vary from wave type to wave type. For example, in sound waves the amplitude is measured in the units of pressure, whereas the amplitude of a water wave would normally be measured in centimetres or metres.

The **wavelength** is the distance between successive corresponding parts of a periodic wave. The wavelength is also the distance travelled by a periodic wave during a time interval of one period. For transverse periodic waves, the wavelength is equal to the distance between successive crests (or troughs). For longitudinal periodic waves, the wavelength is equal to the distance between two successive compressions (regions where particles are closest together) or rarefactions (regions where particles are furthest apart). Wavelength is represented by the symbol  $\lambda$  (lambda).

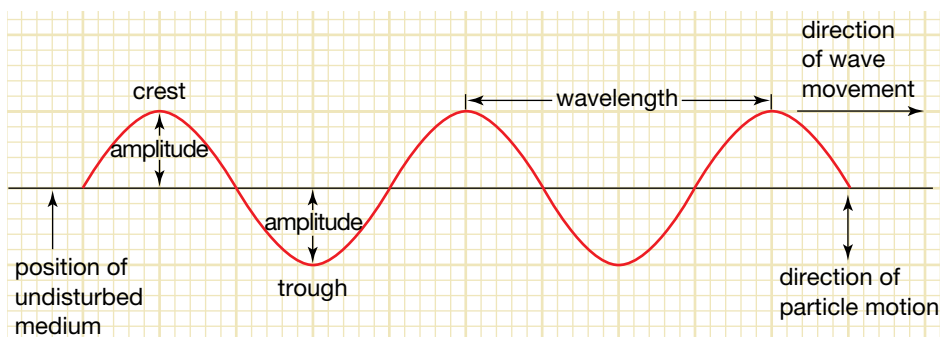

Transverse periodic waves in a piece of string

### study on

Unit 4

AOS 1

Topic 1

Concept 1

#### Characteristics of waves

Concept summary and practice questions

### study on

Unit 4

AOS 1

Topic 1

Concept 2

#### Properties of waves

Concept summary and practice questions

The speed,  $v$ , of a periodic wave is related to the frequency and period. In a time interval of one period,  $T$ , the wave travels a distance of one wavelength,  $\lambda$ . Thus:

$$\text{speed} = \frac{\text{distance}}{\text{time}} = \frac{\lambda}{T} = \frac{\lambda}{\frac{1}{f}} = f\lambda.$$

This relationship,  $v = f\lambda$ , is sometimes referred to as the universal wave equation.

The frequency of a periodic wave is determined by the source of the wave. The speed of a periodic wave is determined by the medium through

which it is travelling. Because the wavelength is a measure of how far a wave travels during a period, if it can't be measured, it can be calculated using the formula  $\lambda = \frac{v}{f}$ .

In a longitudinal wave, as opposed to a transverse wave, the oscillations are parallel to the direction the wave is moving. Longitudinal waves can be set up in a slinky, as shown in part (a) below. Sound waves in air are also longitudinal waves, as shown in part (b) below. They are produced as a vibrating object, such as the arm of a tuning fork, first squashes the air, then pulls back creating a partial vacuum into which the air spreads.

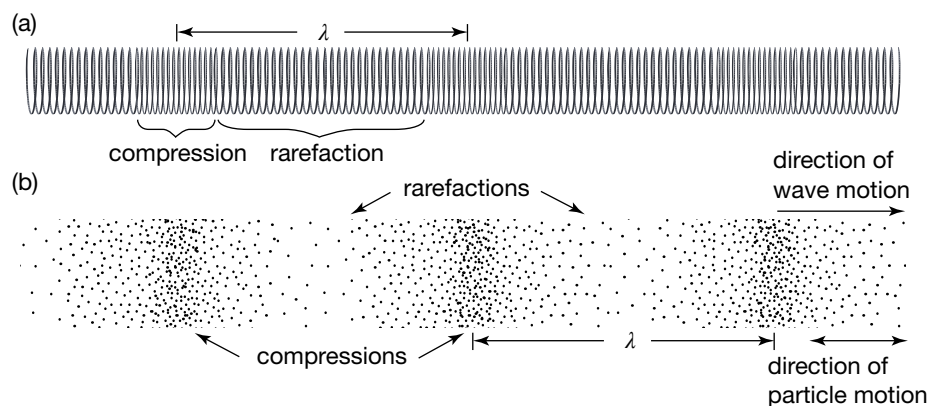

Longitudinal waves in (a) a slinky (b) air

A **compression** is a region of increased pressure in a medium during the transmission of a sound wave.

A **rarefaction** is a region of reduced pressure in a medium during the transmission of a sound wave.

Longitudinal waves cause the medium to bunch up in places and to spread out in others. **Compressions** are regions in the medium where the particles are closer together. Referring to sound waves in air, compressions are regions where the air has a slightly increased pressure, as a result of the particles being closer together. **Rarefactions** are regions in the medium where the particles are spread out. This results in a slight decrease in air pressure in the case of sound waves.

The wavelength ( $\lambda$ ) for longitudinal waves is the distance between the centres of adjacent compressions (or rarefactions). The amplitude of a sound wave in air is the maximum variation of air pressure from normal air pressure.

### Sample problem 9.3

What is the speed of a sound wave if it has a period of 2.0 ms and a wavelength of 68 cm?

**Solution:** **STEP 1:**

Note down the known variables in their appropriate units. Time must be expressed in seconds and length in metres.

$$\begin{aligned} T &= 2.0 \text{ ms} \\ &= 2.0 \times 10^{-3} \text{ s} \\ \lambda &= 68 \text{ cm} \\ &= 0.68 \text{ m} \end{aligned}$$

**STEP 2:**

Choose the appropriate formula.

$$v = \frac{\lambda}{T}$$

**STEP 3:**

Transpose the formula. (Not necessary in this case.)

**STEP 4:**

Substitute values and solve.

$$\begin{aligned} v &= \frac{0.68 \text{ m}}{2.0 \times 10^{-3} \text{ s}} \\ &= 340 \text{ m s}^{-1} \end{aligned}$$

**Sample problem 9.4**

What is the wavelength of a sound of frequency 550 Hz if the speed of sound in air is 335 m s<sup>-1</sup>?

**Solution:**  $f = 550 \text{ Hz}$ ,  $v = 335 \text{ m s}^{-1}$

$$v = f\lambda$$

$$\begin{aligned} \Rightarrow \lambda &= \frac{v}{f} \\ &= \frac{335 \text{ m s}^{-1}}{550 \text{ Hz}} \\ &= 0.609 \text{ m} \end{aligned}$$

**Revision question 9.1**

A siren produces a sound wave with a frequency of 587 Hz. Calculate the speed of sound if the wavelength of the sound is 0.571 m.

**study on**

Unit 4

AOS 1

Topic 1

Concept 3

**Constructive and destructive interference**

Concept summary and practice questions

**Superposition** is the adding together of amplitudes of two or more waves passing through the same point.

## Interference of waves

### Superposition

Pulses (and periodic waves) pass through each other undisturbed. If this were not true, music and conversations would be distorted as the sound waves pass through each other. This can be observed when two pulses pass through each other on a spring. When the pulses are momentarily occupying the same part of the spring, the amplitudes of the individual pulses add together to give the amplitude of the total disturbance of the spring. This effect is known as **superposition** (positioning over) and is illustrated in the following figure.

The shape of the resultant disturbance can be found by applying the superposition principle: *'The resultant wave is the sum of the individual waves'*. For convenience, we can add the individual displacements of the medium at regular intervals where the pulses overlap to get the approximate shape of the resultant wave. Displacements above the position of the undisturbed medium are considered to be positive and those below the position of the undisturbed medium are considered to be negative. This is illustrated in the figure at the top of the next page, in which two pulses have been drawn in red and blue with a background grid. The sum of the displacements on each vertical grid line is shown with a dot and the resultant disturbance, drawn in black, is obtained by drawing a smooth line through the dots.

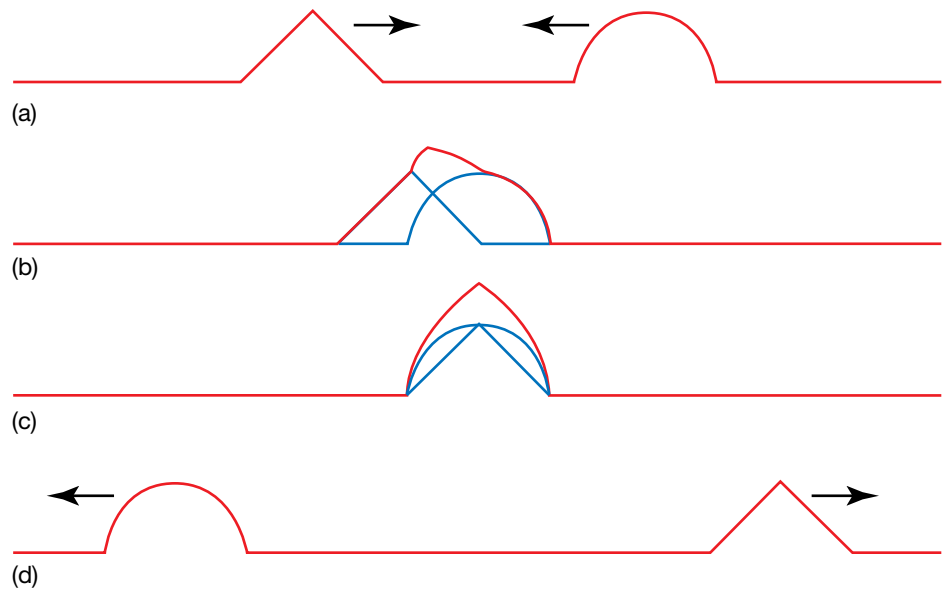

(a) Two pulses of different shapes approach each other on a spring. (b) The pulses begin to pass through each other. (c) As the pulses pass through each other, the amplitudes of the individual pulses add together to give a resultant disturbance. (d) After passing through each other, the pulses continue on undisturbed.

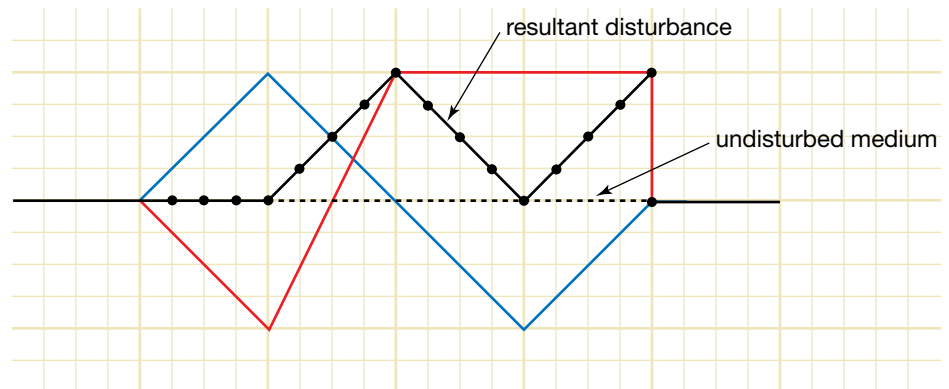

How to obtain the shape of a resultant disturbance

**Destructive interference** is the addition of two wave disturbances to give an amplitude that is less than either of the two waves.

**Constructive interference** describes the addition of two wave disturbances to give an amplitude that is greater than either of the two waves.

Figures (a)–(d) above show that it is possible for a part or whole of a pulse to be ‘cancelled out’ by another pulse. When this effect occurs, destructive superposition, or **destructive interference**, is said to occur. When two pulses superimpose to give a maximum disturbance of a medium, constructive superposition, or **constructive interference**, is said to occur. This effect is shown in figure (c).

## Reflection of waves

When waves arrive at a barrier, reflection occurs. Reflection is the returning of the wave into the medium in which it was originally travelling. When a wave strikes a barrier, or comes to the end of the medium in which it is travelling, at least a part of the wave is reflected.

A wave’s speed depends only on the medium, so the speed of the reflected wave is the same as for the original (incident) wave. The wavelength and frequency of the reflected wave will also be the same as for the incident wave.

### Reflection of transverse waves in strings

When a string has one end fixed so that it is unable to move (for example, when it is tied to a wall or is held tightly to the ‘nut’ at the end of a stringed

**eBookplus**

**Digital doc**

Investigation 9.3

Reflection of pulses in springs

doc-18547

instrument), the reflected wave will be inverted. This is called a change of phase. If the end is free to move, the wave is reflected upright and unchanged, so there is no change of phase. These situations are illustrated in the figure below.

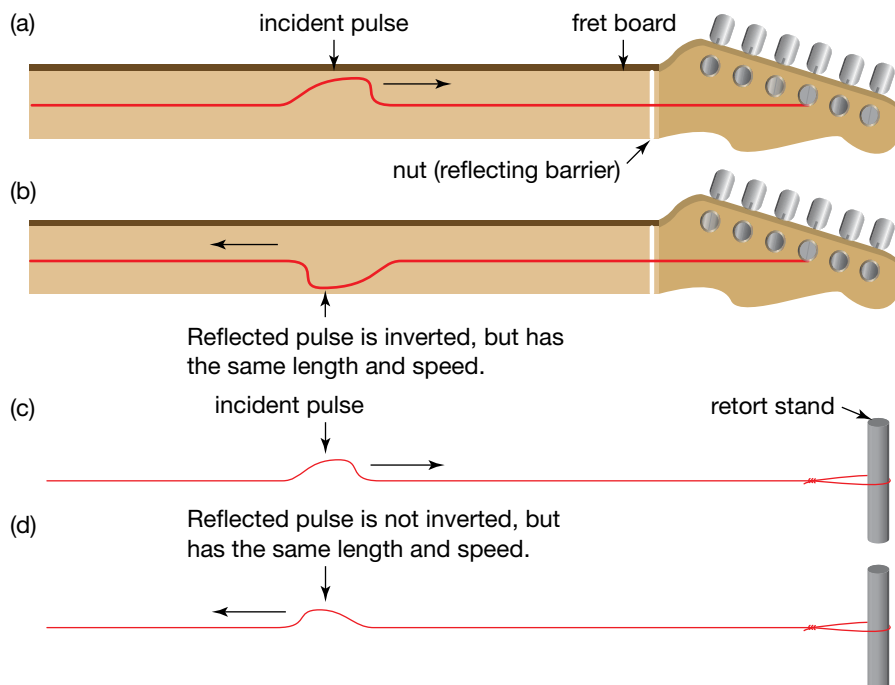

Reflection of a transverse pulse on a string when (a) and (b) the end of the string is fixed (as in a guitar), and when (c) and (d) the end of the string is free to move (as with a loop supported by a retort stand)

A **standing wave** is the superposition of two wave trains at the same frequency and amplitude travelling in opposite directions. Standing waves are also known as stationary waves because they do not appear to move through the medium. The nodes and antinodes remain in a fixed position.

A **node** is a point at which destructive interference takes place.

An **antinode** is a point at which constructive interference takes place.

## Standing waves

**Standing waves** are an example of what happens when two waves pass through the same point in space. They can either interfere constructively or destructively. Interference is explained in chapter 10. Standing waves are an example of interference in a confined space. The restriction may be a guitar string tied down at both ends, or a trumpet closed at the mouthpiece and open at the other end, or even a drum skin stretched tightly and secured at its circumference.

The questions are, How and where do the nodes and antinodes form? and What does this imply about what we hear?

### Transverse standing waves in strings or springs

When two symmetrical periodic waves of equal amplitude and frequency (and therefore wavelength), but travelling in opposite directions, are sent through an elastic one-dimensional medium like a string, spring or a rope, constructive interference and destructive interference occur. In fact, destructive interference occurs at evenly spaced points along the medium and it happens all the time at these points. The medium at these points never moves. Such points in a medium where waves cancel each other at all times are called nodes. In between the **nodes** are points where the waves reinforce each other to give a maximum amplitude of the resultant waveform. This is caused by constructive interference. Such points are called **antinodes**.

When this effect occurs the individual waves are undetectable. All that is observed are points where the medium is stationary and others where the

medium oscillates between two extreme positions. There seems to be a wave, but it has no direction of motion. When this occurs, it is said to be a stationary or standing wave.

The figure below shows how standing waves are formed in a string by two continuous periodic waves travelling in opposite directions. It is important to note that the wavelength of the waves involved in the standing wave is twice the distance between adjacent nodes (or adjacent antinodes).

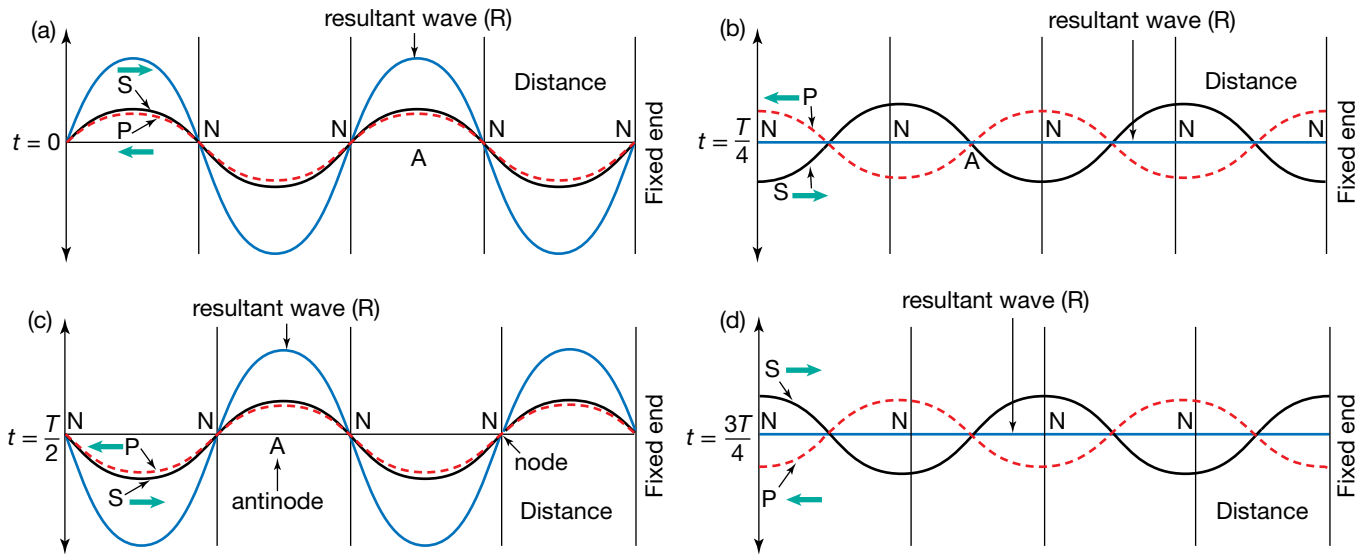

The formation of a standing wave

The figure below shows the motion of a spring as it carries a standing wave. It shows the shape of the spring as it completes one cycle. The time taken to do this is one period ( $T$ ). Note that (i) at  $t = \frac{T}{4}$  and at  $t = \frac{3T}{4}$  the medium is momentarily undisturbed at all points, and (ii) that adjacent antinodes are opposite in phase — when one antinode is a crest, those next to it are troughs.

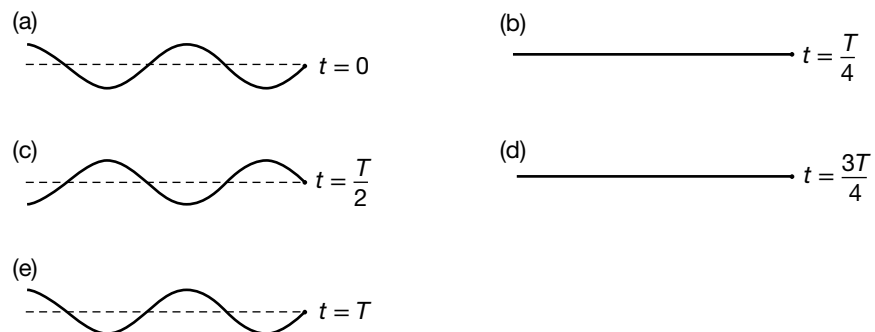

A standing wave over one cycle

### Sample problem 9.5

Two students have created a standing wave in a string, as depicted in the figure above.

- (a) How many nodes are there in the standing wave?
- (b) How many antinodes are there?



- (c) If the students are 8.0 m apart, what is the wavelength of the wave?  
 (d) If the student at the left-hand end of the string is moving her hand at a frequency of 4.0 Hz, what is the speed of the wave?  
 (e) At what frequency would the student need to move her hand to have only one antinode?

- Solution:** (a) There are four nodes, three in the picture and one at the elbow.  
 (b) There are three antinodes.  
 (c) The distance between nodes is given by  $\frac{8.0}{3}$ . The wavelength is twice this distance and equal to:

$$\frac{2 \times 8.0}{3} = 5.3 \text{ m.}$$

- (d) Using  $v = f\lambda$ , speed =  $4.0 \times 5.3 = 21.3 \text{ m s}^{-1} = 21 \text{ m s}^{-1}$ .  
 (e) The speed is unchanged at  $21 \text{ m s}^{-1}$  and the wavelength is now 16 m, so the frequency =  $\frac{21.3}{16} = 1.3 \text{ Hz}$ .

### Revision question 9.2

The spring is now tightened so that the speed is  $30 \text{ m s}^{-1}$ .

- (a) What frequency will be needed to reproduce the pattern in the second figure on the previous page?  
 (b) A pattern is produced that has a wavelength of 8.0 m. Describe the pattern of nodes and antinodes. What is the new frequency?

### study on

Unit 4 **Interference from two sources**

AOS 1

Topic 1

Concept 4

Concept summary and practice questions

## Interference of waves in two dimensions

Interference of waves is best observed in a ripple tank. When two point sources emit continuous waves with the same frequency and amplitude, the waves from each source interfere as they travel away from their respective sources. If the two sources are in phase (producing crests and troughs at the same time as each other), an interference pattern similar to that shown in the following figure is obtained.

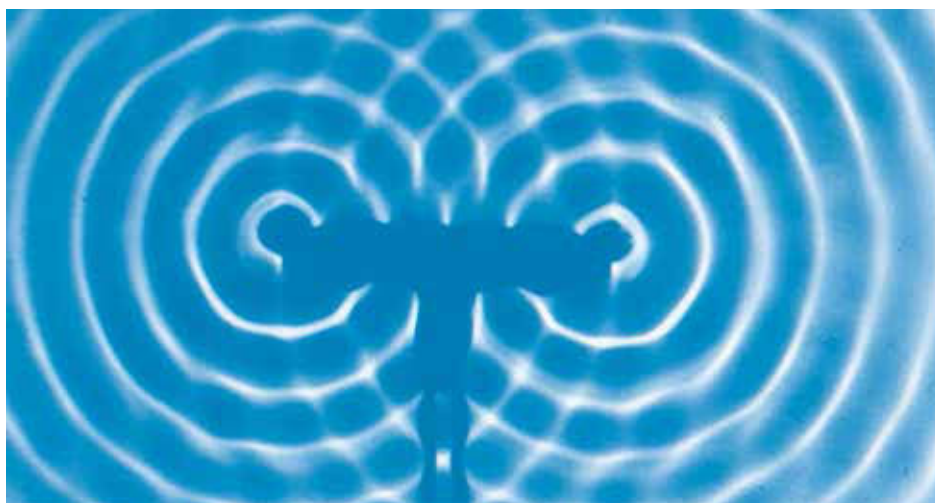

An interference pattern obtained in water by using two point sources that are in phase

**Nodal lines** are lines where destructive interference occurs on a surface, resulting in no displacement of the surface.

Lines are seen on the surface of the water where there is no displacement of the water surface. These lines are called **nodal lines**. They are caused by destructive interference between the two sets of waves. At any point on a nodal line, a crest from one source arrives at the same time as a trough from the other

**Antinodal lines** are lines where constructive interference occurs on a surface.

source, and vice versa. Any point on a nodal line is sometimes called a local minimum, because of the minimum disturbance that occurs there.

Between the nodal lines are regions where constructive interference occurs. The centres of these regions are called **antinodal lines**. At any point on an antinodal line, a crest from one source arrives at the same time as a crest from the other source, or a trough from one source arrives at the same time as a trough from the other source, and so on. Any point on an antinodal line is sometimes called a local maximum, because of the maximum disturbance that occurs there.

When the two sources are in phase, as shown in the figure on the previous page, the interference pattern produced is symmetrical with a central antinodal line. Note that any point on the central antinodal line is an equal distance from each source. Since the sources produce crests at the same time, crests from the two sources will arrive at any point on the central antinodal line at the same time.

Similar analysis will show that, for any point on the first antinodal line on either side of the centre of the pattern, waves from one source have travelled exactly one wavelength further from one source than from the other. This means that crests from one source still coincide with crests from the other, although they were not produced at the same time (see the following figure). Point  $P_A$  is on the first antinodal line from the centre of the pattern. It can be seen that  $P_A$  is 4.5 wavelengths from  $S_1$  and 3.5 wavelengths from  $S_2$ .

A way to establish whether a point is a local maximum or not is to look at the distance it is from both of the two sources. If the distance that the point is from one source is zero or a whole number multiple of the wavelength further than the distance it is from the other source, then that point is a local maximum. This 'rule' can be re-expressed as: *'If the path difference at a point is  $n\lambda$ , the point is a local maximum.'*

Therefore, for a point to be an antinode:

$$d(PS_1) - d(PS_2) = n\lambda \quad n = 0, 1, 2, 3, 4, \dots$$

where

$n$  is the number of the antinodal line from the centre of the pattern

$P$  is the point in question

$S_1$  and  $S_2$  are the sources of the waves

$d(PS_1)$  is the distance from  $P$  to  $S_1$ .

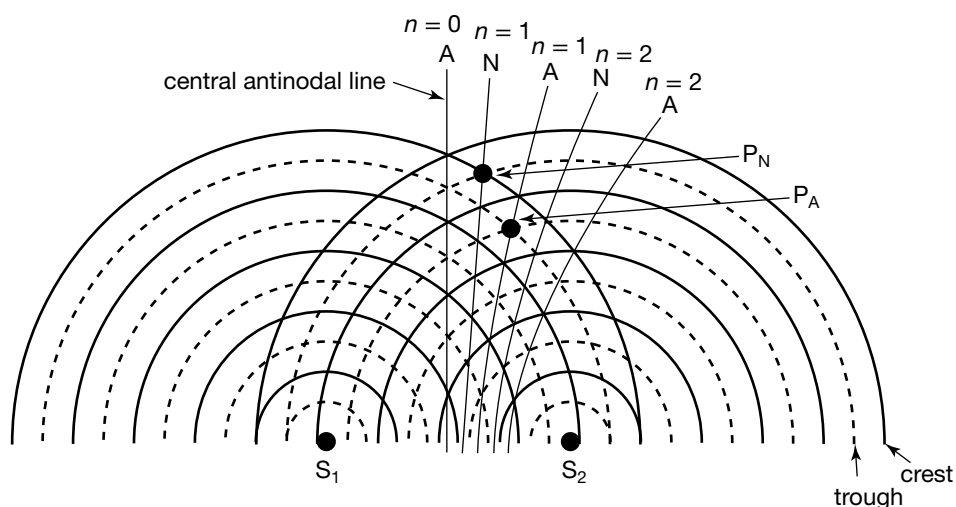

Interference pattern produced by two sources in phase

Similar analysis shows that, for a point on a nodal line, the difference in distance from the point to the two sources is  $\frac{1}{2}\lambda$  or  $1\frac{1}{2}\lambda$  or  $2\frac{1}{2}\lambda$  and so on. This means

that a crest from one source will coincide with a trough from the other source, and vice versa. Point  $P_N$  in the figure is 5 wavelengths from  $S_1$  and 4.5 wavelengths from  $S_2$ .

For a node:

$$d(PS_1) - d(PS_2) = \left(n - \frac{1}{2}\right)\lambda \quad n = 1, 2, 3, 4, \dots$$

where

$n$  is the number of the nodal line obtained by counting outward from the central antinodal line.

### Sample problem 9.6

Two point sources  $S_1$  and  $S_2$  emit waves in phase in a swimming pool. The wavelength of the waves is 1.00 m. P is a point that is 10.00 m from  $S_1$  and P is closer to  $S_2$  than to  $S_1$ . How far is P from  $S_2$  if:

- (a) P is on the first antinodal line from the central antinodal line?  
 (b) P is on the first nodal line from the central antinodal line?

**Solution:** (a)  $d(PS_1)$  is greater than  $d(PS_2)$ ;  $d(PS_1) = 10.00$  m,  $\lambda = 1.00$  m

If P is on the first antinodal line from the central antinodal line, then:

$$d(PS_1) - d(PS_2) = \lambda.$$

Therefore,

$$\begin{aligned} d(PS_2) &= d(PS_1) - \lambda \\ &= 10.00 \text{ m} - 1.00 \text{ m} \\ &= 9.00 \text{ m}. \end{aligned}$$

(b)  $d(PS_1)$  is greater than  $d(PS_2)$ ;  $d(PS_1) = 10.00$  m,  $\lambda = 1.00$  m

If P is on the first nodal line from the central antinodal line, then:

$$d(PS_1) - d(PS_2) = \frac{1}{2}\lambda.$$

Therefore,

$$\begin{aligned} d(PS_2) &= d(PS_1) - \frac{1}{2}\lambda \\ &= 10.00 \text{ m} - 0.50 \text{ m} \\ &= 9.50 \text{ m}. \end{aligned}$$

## Interference with sound

When two sources emit sound with the same frequency in phase, an interference pattern is produced. The pattern is three-dimensional, but its features are the same as for interference patterns produced in water.

A local antinode, or maximum, is a point where constructive interference produces a sound of greater intensity than that produced by one source alone. As the pattern is three dimensional, there is a central antinodal plane (as opposed to a line) where all points are an equal distance from each source. In this plane, a compression from one source coincides with a compression from the other source. This is followed by a progression of coincidental rarefactions and compressions. As the waves pass through such a point, there is a maximum variation in the air pressure, resulting in a louder sound.

A local node, or minimum, is a point where destructive interference produces a sound of much less intensity than that produced by one source alone. At a point in a nodal region, compressions from one source coincide with rarefactions from the other source and vice versa. As the waves pass through such a point, there is very little variation in the air pressure, resulting in a very soft sound.

### AS A MATTER OF FACT

Complete destructive interference rarely occurs as the sounds produced from each source are usually not of equal intensity, due to the different distances travelled by the individual waves and the inverse square law that describes this variation in intensity with distance from the source.

The same formulas that were used for water waves can be used to determine whether a point is part of a nodal or antinodal region.

For a point to be an antinode,

$$d(\text{PS}_1) - d(\text{PS}_2) = n\lambda \quad n = 0, 1, 2, 3, 4, \dots$$

where

$n$  is the number of the antinodal region from the centre of the pattern

P is the point in question

$S_1$  and  $S_2$  are the sound sources.

For a point to be a node,

$$d(\text{PS}_1) - d(\text{PS}_2) = \left(n - \frac{1}{2}\right)\lambda \quad n = 1, 2, 3, 4, \dots$$

where

$n$  is the number of the nodal line obtained by counting outward from the central antinodal plane.

### Sample problem 9.7

A student arranges two loudspeakers, A and B, so that they are connected in phase to an audio amplifier. The speakers are then placed 2.00 m apart and they emit sound which has a wavelength of 0.26 m.

Another student stands at a point P, which is 15.00 m directly in front of speaker B. The situation representing this arrangement is shown in the figure below. Describe what the student standing at point P will hear from this position.

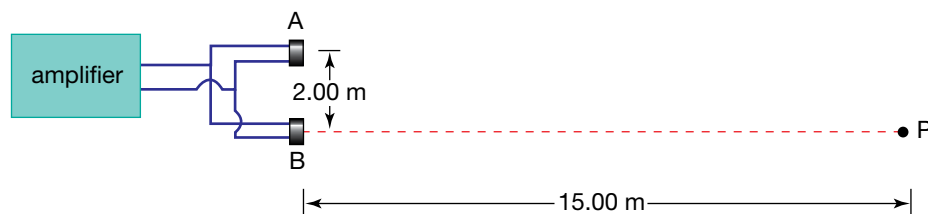

**Solution:** In this type of question, it is important to determine whether the point is a node or antinode.

This is done by determining the path difference and then comparing this to the wavelength.

$$\lambda = 0.26 \text{ m}, d(\text{PB}) = 15.00 \text{ m}$$

$d(\text{PA})$  can be found by applying Pythagoras's theorem.

$$\begin{aligned} d(\text{PA})^2 &= 15.00 \text{ m}^2 + 2.00 \text{ m}^2 \\ &= 229 \text{ m}^2 \end{aligned}$$

$$\text{So } d(\text{PA}) = 15.13 \text{ m}$$

$$d(\text{PA}) - d(\text{PB}) = 15.13 \text{ m} - 15.00 \text{ m} \\ = 0.13 \text{ m.}$$

$$0.13 \text{ m} = \frac{1}{2}\lambda$$

Therefore, the student is at a local minimum and will hear only a very soft sound.

## Colour effects of interference

In the case of light, when two waves of red light meet, constructive interference would result in bright red light. Destructive interference would result in an absence of light, that is, darkness.

When light of a mixture of colours shines on a film of oil in a puddle on the road, light is reflected from the top surface of the oil, as well as from the bottom surface. However, the light from the bottom surface has further to travel; that is, twice the thickness of the oil film. Depending on how this extra distance compares with the wavelength



The colours on this oil film are the result of the interference of light. The wave model of light explains this phenomenon.

of a particular colour, the two waves may undergo constructive or destructive interference. For example, when you look at an oil film, the section that looks yellow is where the thickness is just right for yellow light to undergo maximum constructive interference. Yet at the same place, other colours (which have different wavelengths) undergo destructive interference or less than maximum constructive interference. At other places on the oil film, the thickness will be just right for maximum constructive interference for another colour. The different colours on the oil film indicate the different thicknesses of the oil as the film spreads out.

### eBookplus

**Digital doc**  
Investigation 9.4  
Thin soap films  
doc-18548

In an oil film, the light waves reflecting from the bottom surface interfere with those reflecting from the top surface. Whether the interference is constructive or destructive depends on how the thickness of the film compares with the wavelength of the light.

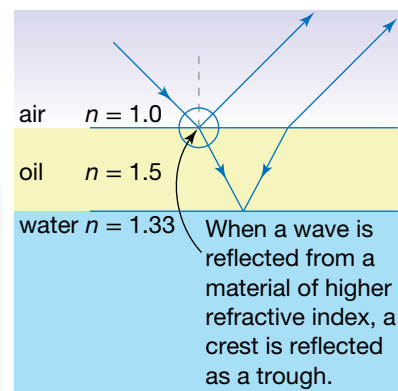

The colours that flash when you move the shiny surface of a CD in sunlight also appear as a result of interference. The light from adjacent ridges in the surface follows paths of very slightly different lengths. The waves interfere with each other. The difference between the lengths of the paths changes because the distance between adjacent ridges changes. Different colours undergo constructive and destructive interference, depending on the path difference.



These colours are the result of interference.

## Diffraction

**Diffraction** is the spreading out, or bending of, waves as they pass through a small opening or move past the edge of an object.

Waves spread out as they pass objects or travel through gaps in barriers. This is readily observable in sound and water waves. For example, you can hear someone speaking in the next room if the door is open, even though there is not a direct straight line between the person and your ears.

**Diffraction** is the directional spread of waves as they pass through gaps or pass around objects. The amount of diffraction depends on the wavelength of the wave and the width of the gap or the size of the obstacle.

For example, the spreading out of sound from loudspeakers is the result of diffraction. The sound waves spread out as they pass through the opening in the front of the loudspeaker. Without diffraction, hardly any sound would be heard other than from directly in front of the speaker cone.

### eBookplus

#### Digital doc

Investigation 9.5  
Diffraction of waves in a ripple tank  
doc-18549

### study on

#### Unit 4

#### Diffraction

#### AOS 1

Concept summary and practice questions

#### Topic 1

#### Concept 6

## Diffraction of water waves

The diffraction of sound can be modelled with water waves in a ripple tank. The next figure shows the way water waves diffract in various situations. The diagrams apply equally well to the diffraction of sound waves.

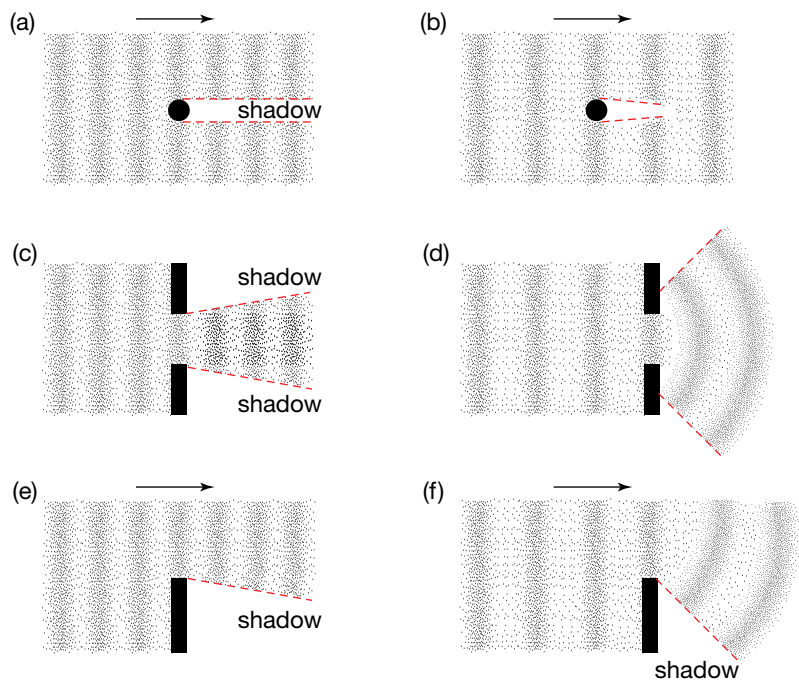

Diffraction of water waves:  
(a) short wavelength around an object, (b) long wavelength around the same object, (c) short wavelength through a gap, (d) long wavelength through the same gap, (e) short wavelength around the edge of a barrier and (f) long wavelength around the edge of the same barrier

The region where no waves travel is called a shadow. The amount of diffraction that occurs depends on the wavelength of the waves. The longer the wavelength, the more diffraction occurs. As a general rule, if the wavelength is less than the size of the object, there will be a significant shadow region.

When waves diffract through a gap of width  $w$  in a barrier, the ratio  $\frac{\lambda}{w}$  is important. As the value of this ratio increases, so, too, does the amount of diffraction that occurs.

### AS A MATTER OF FACT

Barriers built next to freeways are effective in protecting nearby residents from high-frequency sounds as these have a short wavelength and undergo little diffraction. The low-frequency sounds from motors and tyres, however, diffract around the barriers because of their longer wavelengths.

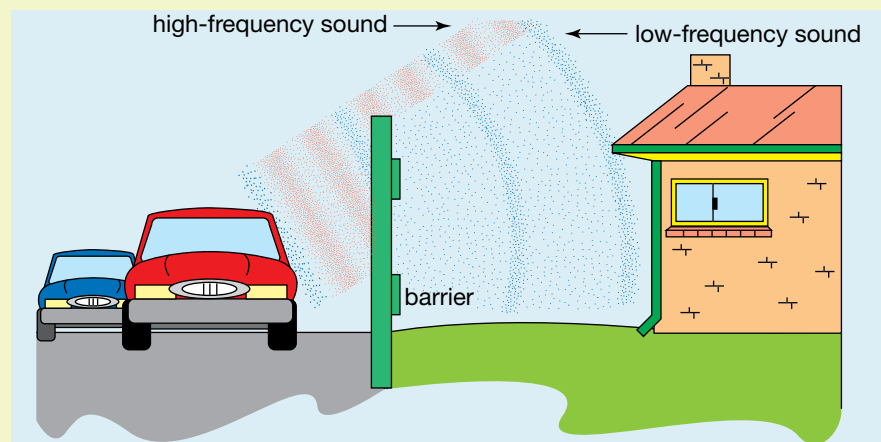

The diffraction of low and high frequencies around a freeway barrier

The diffraction of high and low frequencies from a loudspeaker

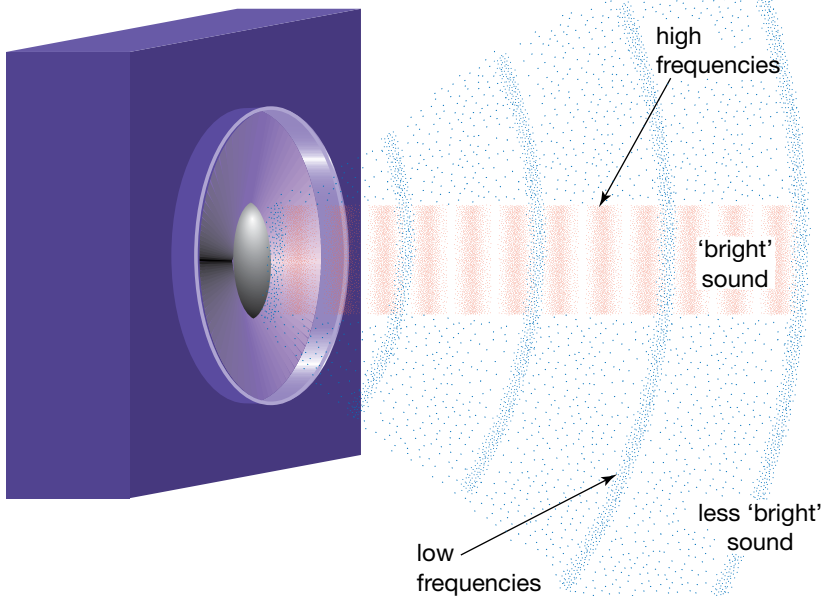

### Directional spread of different frequencies

The opening at the end of a wind instrument such as a trumpet, the size of someone's mouth and the size of a loudspeaker opening all affect the amount of diffraction that occurs in the sound produced. High-frequency sounds can best be heard directly in front of these devices.

When a loudspeaker plays music, it is reproducing more than one frequency at a time. Low-frequency soundwaves from a bass have a large wavelength; high-frequency soundwaves from a trumpet have a short wavelength. Short-wavelength, high-frequency sounds do not diffract (spread out) very much when they emerge from the opening of a loudspeaker, but long wavelength sounds do. If a single loudspeaker is used, the best place to hear the sound is directly in front of the speaker.

### Sample problem 9.8

Two sirens are used to produce frequencies of 200 Hz and 10 000 Hz. Describe the spread of the two sounds as they pass through a window in a wall. The window has a width of 35 cm. Assume that the speed of sound in air is  $330 \text{ m s}^{-1}$ .

**Solution:** First calculate the wavelengths of the sounds using the formula  $v = f\lambda$ . These calculate to 165 cm and 3.3 cm respectively. There will be a very small diffraction spread for the sound of wavelength 3.3 cm because the wavelength is small compared with the opening. There will be a large diffraction spread for the sound of wavelength 165 cm because the wavelength is large compared with the opening.

#### eBookplus

##### Digital doc

Investigation 9.6  
The Doppler effect

doc-18550

#### study on

Unit 4

**The Doppler effect**

AOS 1

Concept summary  
and practice  
questions

Topic 1

Concept 7

## The Doppler effect

We are all familiar with the change in pitch as a noisy car passes us. This is most pronounced when an emergency vehicle races by. Think of the sounds people make when mimicking passing racing cars. The sound always starts high but finishes low. This is called the Doppler effect, after Christian Johann Doppler who predicted it in 1842 before it had been observed. (Vehicles were slow then!) The Doppler effect is the result of the wave travelling at a constant speed through the medium while the source is in motion relative to the medium.

Consider a fire-engine racing to attend a fire. While it is stuck in traffic with its siren blaring, a Physics student decides to measure the frequency and wavelength of the sound. The fire-engine's siren alternates between a high-pitched sound and a low-pitched sound. He measures the high-pitched sound to have a frequency of 500 Hz and the low-pitched sound to have a frequency of 200 Hz. After determining the speed of sound to be  $340 \text{ m s}^{-1}$ , and noticing that there is no wind, he calculates the wavelengths using  $v = f\lambda$ .

$$\begin{aligned}\lambda &= \frac{v}{f} \\ &= \frac{340 \text{ m s}^{-1}}{500 \text{ Hz}} \\ &= 0.680 \text{ m for the 500 Hz sound}\end{aligned}$$

$$\begin{aligned}\lambda &= \frac{v}{f} \\ &= \frac{340 \text{ m s}^{-1}}{200 \text{ Hz}} \\ &= 1.70 \text{ m for the 200 Hz sound}\end{aligned}$$

Later, the traffic jam has cleared and the fire-engine passes the physics student. The fire-engine travels at a velocity of  $24 \text{ m s}^{-1}$  relative to the road (and air). The speed of sound remains at  $340 \text{ m s}^{-1}$  through the air. The fire-engine is identical to the first one; but now the student measures the frequencies to be 538 Hz and 215 Hz as the fire-engine approaches, and 467 Hz and 187 Hz as the fire-engine moves away. His frequency-measuring equipment is not faulty — he could clearly hear the pitch drop as the fire-engine passed him. When the air is still, something approaching you will sound higher in pitch than when it is at rest relative to you, and will sound lower in pitch when it is moving away from you. Doppler cleverly predicted this result before the advent of fast fire-engines. His prediction was first confirmed experimentally by having a trumpeter play a note while passing on a 'relatively' fast-moving train.

The sound produced by the siren of the fire-engine is a series of pressure variations in the air. When the fire-engine produces a compression (region of

#### eBookplus

##### Weblink

Doppler effect applet



(a) Stationary source

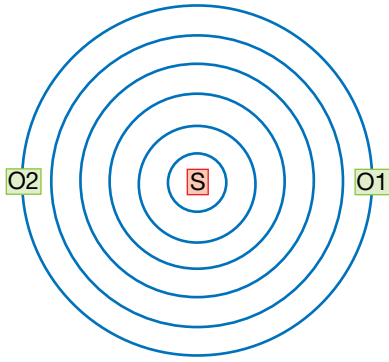

(b) Source moving to the right

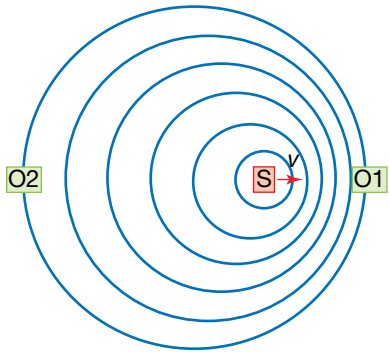

**Legend:**

- S = Source
- O1 = Observer in front of sound source
- O2 = Observer behind sound source

The Doppler effect, (a) O1 and O2 both hear the same frequency sound. (b) O1 hears a higher frequency than O2.

higher-than-average air pressure) of the high-frequency sound, this compression moves forward at the speed of sound in air,  $340 \text{ m s}^{-1}$ . The next compression is produced  $T$  seconds later, where  $T$  is the period of the soundwave.

$$\begin{aligned}
 T &= \frac{1}{f} \\
 &= \frac{1}{500 \text{ Hz}} \\
 &= 0.002 \text{ s later when the first compression has travelled:} \\
 d &= vt \\
 &= 340 \text{ m s}^{-1} \times 0.002 \text{ s} \\
 &= 0.68 \text{ m.}
 \end{aligned}$$

In this time the fire-engine has moved:

$$\begin{aligned}
 d &= vt \\
 &= 24 \text{ m s}^{-1} \times 0.002 \text{ s} \\
 &= 0.048 \text{ m.}
 \end{aligned}$$

The distance between compressions is therefore:

$$\begin{aligned}
 \lambda &= 0.68 \text{ m} - 0.048 \text{ m} \\
 &= 0.632 \text{ m.}
 \end{aligned}$$

For the fire-engine that was stationary, the wavelength was 0.68 m. As sound is travelling at  $340 \text{ m s}^{-1}$  relative to the student on the roadside for fire-engines, and  $v = f\lambda$ , the shorter wavelength from the approaching fire-engines will have a higher frequency than the stationary fire-engines. In this case the detected frequency would be:

$$\begin{aligned}
 f &= \frac{v}{\lambda} \\
 &= \frac{340 \text{ m s}^{-1}}{0.632 \text{ m}} \\
 &= 538 \text{ Hz, measured by the student for the } 500 \text{ Hz sound as the fire-engine approached at } 24 \text{ m s}^{-1}.
 \end{aligned}$$

In order to derive a formula for the Doppler effect, let the speed of sound be  $v_s$  and the speed of the sound source (fire-engine) relative to the observer be  $v$ . The driver of the fire-engine measures the velocity of the sound of his siren to be  $v_s - v$  in the forward direction, and  $v_s + v$  in the reverse direction. As  $v = f\lambda$ , the wavelength of the sound in front of the fire-engine is given by  $\frac{v_s - v}{f_o}$ , while behind the fire-engine the wavelength is  $\frac{v_s + v}{f_o}$ , where  $f_o$  is the frequency of the sound emitted.

Now consider the frequency heard by an observer standing on the roadside. For him the sound has a relative velocity of  $v_s \text{ m s}^{-1}$  because he is at rest relative to the air carrying the sound waves (assuming no wind).

The wavelength has been determined already, so while the fire-engine is moving towards the observer, the frequency is:

$$\begin{aligned}
 f &= \frac{v_s}{\left(\frac{v_s - v}{f_o}\right)} \\
 &= \frac{v_s f_o}{(v_s - v)}.
 \end{aligned}$$

When the fire-engine is moving away, the frequency is:

$$f = \frac{v_s}{\left(\frac{v_s + v}{f_o}\right)}$$

$$= \frac{v_s f_o}{(v_s + v)}$$

Notice that the frequency will always be heard as higher than the frequency produced by the sound source when the sound source approaches the observer, and lower as it moves away. This agrees with the results of the physics student's observations of the fire-engine and our experiences of noisy vehicles racing by.

Electromagnetic radiation is a different type of wave. Are light, radio waves and other parts of the electromagnetic spectrum also susceptible to the Doppler effect? The answer is yes. Police radar guns, for example, make use of the Doppler effect. They emit radio waves travelling with a velocity of  $3 \times 10^8 \text{ m s}^{-1}$ . The gun sends radio waves of a particular frequency and measures the frequency of the radiation that it receives after the waves reflect off the car. However, with sound we have been able to refer to its velocity relative to its medium. What that means in terms of light and other forms of electromagnetic radiation will become clearer in what is to follow.

### Sample problem 9.9

A noisy truck approaches a stationary pedestrian operating a frequency meter. The truck motor roars at a frequency of 2000 Hz as it approaches the pedestrian and 1500 Hz as it moves away. What is the speed of the truck relative to the pedestrian? Take the speed of sound in air to be  $340 \text{ m s}^{-1}$ .

**Solution:** Using the Doppler formulae, as the truck approaches, the frequency is:

$$f = \frac{v_s f_o}{(v_s - v)}$$

$$2000 \text{ Hz} = \frac{340 \text{ m s}^{-1} f_o}{(340 \text{ m s}^{-1} - v)}$$

As the truck recedes, the frequency is:

$$f = \frac{v_s f_o}{(v_s + v)}$$

$$1500 \text{ Hz} = \frac{340 \text{ m s}^{-1} f_o}{(340 \text{ m s}^{-1} + v)}$$

We now have two equations for  $f_o$  and  $v$ . We can solve them for  $v$  by dividing the first equations by the second to eliminate  $f_o$ :

$$\frac{340 \text{ m s}^{-1} + v}{340 \text{ m s}^{-1} - v} = \frac{4}{3}$$

$$3(340 \text{ m s}^{-1} + v) = 4(340 \text{ m s}^{-1} - v)$$

$$7v = 340 \text{ m s}^{-1}$$

$$v = 48.6 \text{ m s}^{-1}$$

The truck must be moving at  $48.6 \text{ m s}^{-1}$  relative to the air. (This truck is well over the speed limit.)

The analysis presented above assumes that the sound source moves directly toward, and then directly away, from the observer. The change in frequency will be gradual for someone not directly in the path of the sound, as suggested by figure (b) on page 219. It also assumes that the sound receiver is at rest relative to the medium of the sound.

It is possible to travel faster than sound. Some aircraft and missiles travel faster than sound. This speed can make weapons particularly menacing. For example, the V-2 bombs used in World War II struck English cities before their inhabitants could hear them coming. Also, the constructive interference of the sound waves overlapping when the sound barrier was broken carried sufficient energy to break windows after the sound source had passed.

The Doppler effect can be observed in light waves, but the nature of light demands Einstein's relativity theory be applied. A change in the frequency of light corresponds with a change in the colour of the light. The characteristic patterns of elements visible in starlight passed through a spectroscope are shifted towards the red (long wavelength) end of the spectrum if the star is moving further away from us. If the star is moving closer to us, the spectrum of the starlight is shifted towards the blue (short wavelength) end of the spectrum. This makes calculating the 'radial' component of a star's velocity relative to the Earth straightforward. The transverse component of a star's velocity does not influence the Doppler effect and must be measured some other way. Use of the Doppler effect led to the big bang theory. Measuring the radial speed of galaxies, astronomers in the early twentieth century discovered that most of them were moving away from us. Edwin Hubble found that the speed was greater for those galaxies further from us, and drew the conclusion that the universe has expanded from a single point.

The Doppler effect is an example of how object moving relative to an observer may seem to be different because of their movement. However, this is only the beginning. The universe 'as we know it' takes on a whole new meaning when the principle of relativity is applied to all aspects of physics.

The Doppler effect applies to all types of wave motion and has been observed with light waves. Astronomers use the Doppler effect to determine the speed with which stars are travelling towards or away from the Earth. If they are travelling away from the Earth, the wavelengths of light will be longer and the characteristic spectrum of the star will be shifted towards the red end of the spectrum. This effect is known as 'red shift'.

**Resonance** is the condition where a medium responds to a periodic external force by vibrating with the same frequency as the force.

### study on

Unit 4

AOS 1

Topic 1

Concept 5

### Resonance

Concept summary and practice questions

## Resonance

**Resonance** is the vibration of an object caused when a forced oscillation matches the object's natural frequency of vibration.

Every object has one or more natural frequencies of vibration. For example, when a crystal wine glass is struck with a spoon, a distinct pitch of sound is heard. If the resonant frequency is produced by a sound source near the glass, the glass will begin to vibrate. In this case, the alternating driving force is provided by the variations in air pressure at the surface of the glass due to the sound produced by the sound source.

If the intensity of the external sound is increased, it is possible to increase the amplitude of the vibrations in the crystal wine glass until the crystal lattice falls apart and the glass shatters. Note, however, that resonance does not necessarily mean that something will break!



# Chapter review

## Summary

- Light sources are called luminous objects. Some luminous objects give off light because they are hot; these are called incandescent objects.
- Light travels in straight lines through air at a speed of  $3.0 \times 10^8 \text{ m s}^{-1}$ . Shadows provide evidence that light travels in straight lines.
- Modelling light as a pencil-like ray helps describe the reflection of light.
- When light meets a surface the angle of incidence equals the angle of reflection. The incident ray, the normal to the surface and the reflected ray all lie in the same plane.
- Waves are a means of energy transfer without matter transfer. There are many examples of waves and they can be transverse or longitudinal.
- Properties of waves that can be measured include speed, wavelength and frequency. These quantities are connected by the universal wave equation: speed = frequency  $\times$  wavelength, or  $v = f\lambda$ .
- Light is a form of electromagnetic radiation that can be modelled as transverse waves with colours differing in frequency and wavelength.
- Waves, including light, have the capacity to interfere with each other, producing constructive interference or destructive interference when two waves meet.
- Standing waves are caused by the superposition of two wave trains of the same frequency travelling in opposite directions.
- Some colour effects that we see are the result of the interference of light.
- The Doppler effect is the result of a wave source moving through the medium. The waves move at constant speed relative to the medium, resulting in a higher frequency in front of the moving source and a lower frequency behind. The frequency in front of the source is given by  $f = \frac{v_s f_0}{(v_s - v)}$  and behind the source by  $f = \frac{v_s f_0}{(v_s + v)}$  where  $v_s$  is the speed of sound in the air,  $f_0$  is the frequency of the source and  $v$  is the velocity of the source through the air.
- Sound waves are longitudinal.
- As longitudinal waves move through a medium, the particles of the medium vibrate parallel to the direction of propagation.
- Resonance is the condition where a medium responds to a periodic external force by vibrating with the same frequency as the force.

## Questions

### Light and its properties

- Calculate the longest and shortest time for a radio signal travelling at the speed of light to go from the Earth to a space probe when the space probe is (a) near Mars and (b) near Neptune.

$$\begin{aligned} \text{Radius of Earth's orbit about the Sun} \\ = 1.49 \times 10^{11} \text{ m} \end{aligned}$$

$$\begin{aligned} \text{Radius of Mars's orbit about the Sun} \\ = 2.28 \times 10^{11} \text{ m} \end{aligned}$$

$$\begin{aligned} \text{Radius of Neptune's orbit about the Sun} \\ = 4.50 \times 10^{12} \text{ m} \end{aligned}$$

- How is a periodic wave different from a single pulse moving along a rope?
- Ripples on a pond are caused when drops of water fall on the surface at the rate of 5 drops every 10 seconds. What is:
  - the period of the ripples
  - the frequency of the ripples?
- In each of the diagrams below, two waves move towards each other. Which diagram or diagrams show waves that, as they pass through each other, could experience:
  - only destructive interference
  - only constructive interference?

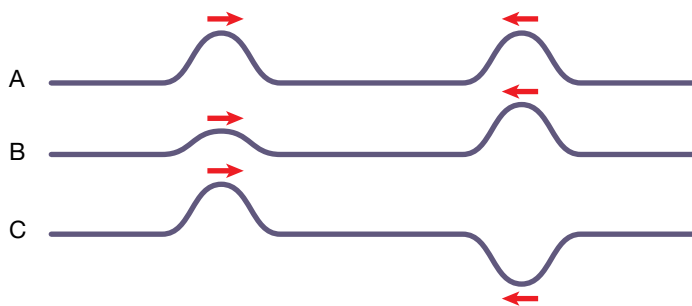

- Calculate the period of orange light, which has a frequency of  $4.8 \times 10^{14} \text{ Hz}$ .

### Wave speed or velocity

- What is the speed of sound in air if it travels a distance of 996 m in 3.0 s?
- How far does a wave travel in one period?
- Do loud sounds travel faster than soft sounds? Justify your answer.
- A marching band on the other side of a sports oval appears to be 'out of step' with the music. Explain why this might happen.

10. You arrive late to an outdoor concert and have to sit 500 m from the stage. Will you hear high-frequency sounds at the same time as low-frequency sounds if they are played simultaneously? Explain your answer.
11. A loudspeaker is producing a note of 256 Hz. How long does it take for 200 wavelengths to interact with your ear?
12. During an electrical storm the thunder and lightning occur at the same time and place. Unless the centre of the storm is directly above, you see the lightning flash before you hear the thunder. How far away is lightning if it takes 5.0 s for the sound of thunder to reach you after the flash is seen? Assume the speed of sound in air is  $335 \text{ m s}^{-1}$ .

### The wave equation

13. What is the wavelength of a sound that has a speed of  $340 \text{ m s}^{-1}$  and a period of 3.0 ms?
14. What is the speed of a sound if the wavelength is 1.32 m and the period is  $4.0 \times 10^{-3} \text{ s}$ ?
15. The speed of sound in air is  $340 \text{ m s}^{-1}$  and a note is produced that has a frequency of 256 Hz.  
(a) What is its wavelength?  
(b) This same note is now produced in water where the speed of sound is  $1.50 \times 10^3 \text{ m s}^{-1}$ . What is the new wavelength of the note?
16. Copy and complete table 9.2 by applying the universal wave formula.

TABLE 9.2

$v \text{ (m s}^{-1}\text{)}$	$f \text{ (Hz)}$	$\lambda \text{ (m)}$
	500	0.67
	12	25
1500		0.30
60		2.5
340	1000	
260	440	

### Interference

17. What is superposition and when does it occur?
18. What is constructive interference and when does it occur?
19. Describe the interference pattern produced when two sound sources produce sounds of equal frequency in phase. How can you determine whether a point on the interference pattern is a local maximum or local minimum?

### Transverse standing waves in strings

20. The figure below shows the positions of three sets of two pulses as they pass through each other.

Copy the diagram and sketch the shape of the resultant disturbances.

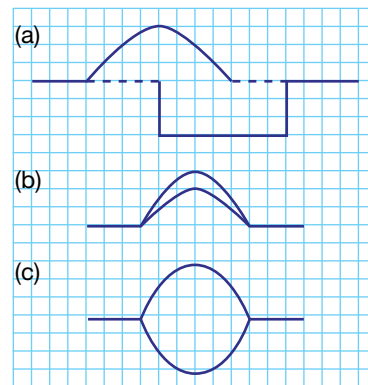

21. What is the wavelength of a standing wave if the nodes are separated by a distance of 0.75 m?
22. The figure below shows a standing wave in a string. At that instant ( $t = 0$ ) all points of the string are at their maximum displacement from their rest positions.



If the period of the standing wave is 0.40 s, sketch diagrams to show the shape of the string at the following times:

- (a)  $t = 0.05 \text{ s}$   
(b)  $t = 0.1 \text{ s}$   
(c)  $t = 0.2 \text{ s}$   
(d)  $t = 0.4 \text{ s}$ .

### Sound and standing waves

23. Kim and Jasmine set up two loudspeakers in accordance with the following arrangements:
- They faced each other.
  - They were 10 m apart.
  - The speakers are in phase and produce a sound of 330 Hz.

Jasmine uses a microphone connected to a CRO and detects a series of points between the speakers where the sound intensity is a maximum. These points are at distances of 3.5 m, 4.0 m and 4.5 m from one of the speakers.

- (a) What causes the maximum sound intensities at these points?  
(b) What is the wavelength of the sound being used?  
(c) What is the speed of sound on this occasion?
24. A standing wave is set up by sending continuous waves from opposite ends of a string. The frequency of the waves is 4.0 Hz, the wavelength is 1.2 m and the amplitude is 10 cm.
- (a) What is the speed of the waves in the string?  
(b) What is the distance between the nodes of the standing wave?  
(c) What is the maximum displacement of the string from its rest position?

- (d) What is the wavelength of the standing wave?  
 (e) How many times per second is the string straight?
25. A standing wave is set up by sending continuous waves from opposite ends of a string. The frequency of the waves is 2.5 Hz, the wavelength is 2.4 m and the amplitude is 0.04 m.
- (a) What is the speed of the waves in the string?  
 (b) What is the distance between the nodes of the standing wave?  
 (c) What is the maximum displacement of the string from its rest position?  
 (d) What is the wavelength of the standing wave?  
 (e) How many times per second is the string straight?
26. Explain what is meant by the expression 'interference pattern' when applied to two sound sources that are in phase.
27. Describe the interference pattern produced by two sound sources that are in phase.
28. What happens to cause a nodal line when sound is emitted by two sources in phase?
29. What effect would increasing the wavelength of the sound have on the interference pattern produced by two sound sources that are in phase?
30. Two sources in phase emit sound with a wavelength of 0.90 m. Describe the loudness (louder or softer when compared to that produced by a single source) at the following positions:
- (a) at an equal distance from both sources  
 (b) at a distance of 15.45 m from one source and 14.55 m from the other  
 (c) at a distance of 15.75 m from one source and 16.20 m from the other.
- Justify your answers.
31. Two loudspeakers are set up on an open-air stage as shown below.



A sound engineer tests the arrangement by feeding a tone of 660 Hz through both speakers. For the following questions, assume that:

- the speakers are producing sound in phase
  - the speed of sound in air is  $330 \text{ m s}^{-1}$ .
- (a) What is the wavelength of the sound that is produced by each speaker?  
 (b) The engineer walks directly away from one of the speakers until he notices that the sound has a minimum value at point P. He accurately measures the distance from this point to the nearest speaker ( $S_1$ ) and finds that it is 17.875 m. How far is he from speaker  $S_2$ ? (In

calculating this distance, assume that P is on the first nodal line.)

- (c) How far apart are the speakers?
32. Two loudspeakers in phase produce an interference pattern on a sports field. The set-up of the apparatus is shown below.
- The speakers produce sound with a wavelength of 0.80 m. Suroor walks from point A to point I and detects either a loud or very soft sound at the points labelled in the diagram.
- (a) What causes the variations in the loudness of the sound?  
 (b) Describe the sound (loud or soft) detected at point E. Explain your answer.  
 (c) Describe the sound (loud or soft) detected at point D. Explain your answer.  
 (d) If point D is 20.00 m from speaker  $S_2$ , how far is it from speaker  $S_1$ ?  
 (e) Suroor stands at point D as her assistant Susie slowly increases the frequency while keeping the power of the speakers constant. Describe the loudness of the sound that Suroor detects as the frequency increases. Justify your answer.

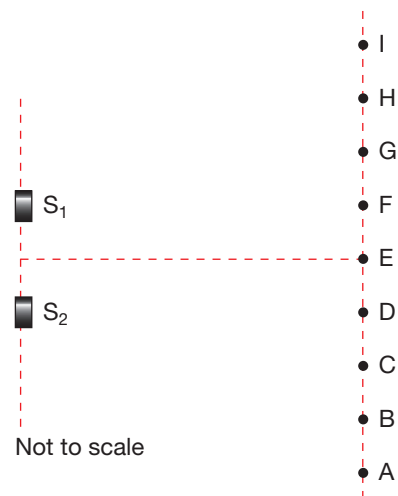

### Diffraction

33. (a) What is diffraction?  
 (b) Why is diffraction an important concept to consider when designing loudspeakers?
34. The figure below shows the design of a dentist's waiting room and surgery.

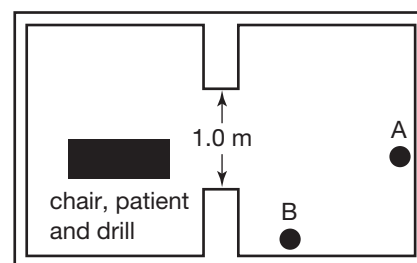

There are two people sitting in the waiting room at points A and B. The door to the surgery is open and has a width of 1.0 m. A drill is operating and produces a sound of 5000 Hz frequency. The patient groans at a frequency of 200 Hz. Assume the speed of sound is  $340 \text{ m s}^{-1}$ .

- What is the wavelength of the patient's groan?
- What difference, if any, is there between the sound intensity levels produced by the patient's groan at points A and B? Justify your answer.
- What difference, if any, is there between the sound intensity levels produced by the dentist's drill at points A and B? Justify your answer.

**35.** A 1500 Hz sound and a 8500 Hz sound are emitted from a loudspeaker whose diameter is 0.30 m. Assume the speed of sound in air is  $343 \text{ m s}^{-1}$ .

- Calculate the wavelength of each sound.
- Find the angle of the first minimum for each sound for this speaker.
- A sound engineer wants to use a different speaker for the 8500 Hz sound so that it has the same angle of dispersion as the 1500 Hz has for the 0.30 m diameter speaker. Calculate the diameter of the new speaker if this is to occur.

**36.** A sound of wavelength  $\lambda$  passes through a gap of width  $w$  in a barrier. How will the following changes affect the amount of diffraction that occurs?

- $\lambda$  decreases.
- $\lambda$  increases.
- $w$  decreases.
- $w$  increases.

### The Doppler effect

**37.** A trumpeter on a moving train first demonstrated the Doppler effect. (Use  $340 \text{ m s}^{-1}$  as the speed of sound.)

- How fast would the train be travelling if the trumpeter played an A ( $f = 440 \text{ Hz}$ ) and the observers on the platform heard an A sharp ( $f = 466 \text{ Hz}$ )?

- What frequency would the observers hear once the train had passed?
- How fast would the train need to be travelling for the pitch of the note to rise a full octave (that is, double its frequency)?

**38.** Lyn cannot hear sound above  $1.5 \times 10^4 \text{ Hz}$ .

She decided to investigate the Doppler effect by strapping a speaker to the roof of a car. She connects a signal generator to the speaker so that it produces a sound of frequency  $1.2 \times 10^4 \text{ Hz}$ . She predicts that if the car is driven towards her with sufficient speed she will not be able to hear the sound.

(a) At what speed can she no longer hear the sound? (Assume there are no other sounds to drown it out.)

(b) What does she hear as the car accelerates?

**39.** Shelly is concerned about the speed of traffic in her street. She measures the dominant frequency of the sound of a car as it approaches to be 1100 Hz, and as it moves away to be 919 Hz. What was the speed of the car? (Take the speed of sound in air to be  $340 \text{ m s}^{-1}$ .)

**40.** In this chapter we considered the Doppler effect for the case where the source is moving. If the source is at rest in air but the receiver is moving towards the source with speed  $v$ , then the frequency heard by the receiver is given by

$$f = f_o \left( 1 + \frac{v}{v_s} \right), \text{ where } f_o \text{ is the frequency of the}$$

sources,  $v$  is the speed of the receiver and  $v_s$  is the speed of sound.

(a) If the sound source in question 38 was at rest in the air and Lyn drove her car towards it, what would be her speed when she can no longer hear the sound? (Use  $v_s = 340 \text{ m s}^{-1}$ .)

(b) Derive the formula  $f = f_o \left( 1 + \frac{v}{v_s} \right)$ .

(Hint: Put yourself in the reference frame of the sound wave.)

**REMEMBER**

Before beginning this chapter, you should be able to:

- recall that waves transmit energy without the net transfer of matter
- identify the wavelength, period and frequency of a wave
- use the wave equation  $v = f\lambda$
- explain constructive and destructive interference of waves from two point sources with reference to the effect of path difference
- explain the diffraction of waves and how the spreading of the wave depends on wavelength and gap width.

**KEY IDEAS**

After completing this chapter, you should be able to:

- describe the bending of light as it passes from one medium into another
- use the ray model to describe the refraction of light
- mathematically model refraction using Snell's Law
- use the ray model of light to describe and explain total internal reflection and mirages
- recognise light as part of the electromagnetic spectrum
- apply a wave model to the behaviour of light and the rest of the electromagnetic spectrum
- describe the dispersion of light in prisms, lenses and optical fibres
- describe polarisation in terms of a wave model
- discuss the results of Young's double-slit experiment as evidence for the wavelike nature of light in terms of the constructive and destructive interference of waves
- interpret the pattern produced by light when it passes through a small gap or past an obstacle in terms of the diffraction of waves
- make qualitative predictions of changes in diffraction patterns due to width of gap or diameter of object or wavelength of light
- describe light as an electromagnetic wave that is produced by the acceleration of charges, which in turn produces changing electric fields and associate changing magnetic fields
- understand that all electromagnetic waves travel at the same speed,  $c$ , in a vacuum
- compare the wavelengths and frequencies of different regions of the electromagnetic spectrum, and identify the uses of each region.

Understanding light as a wave helps to explain many physical phenomena.

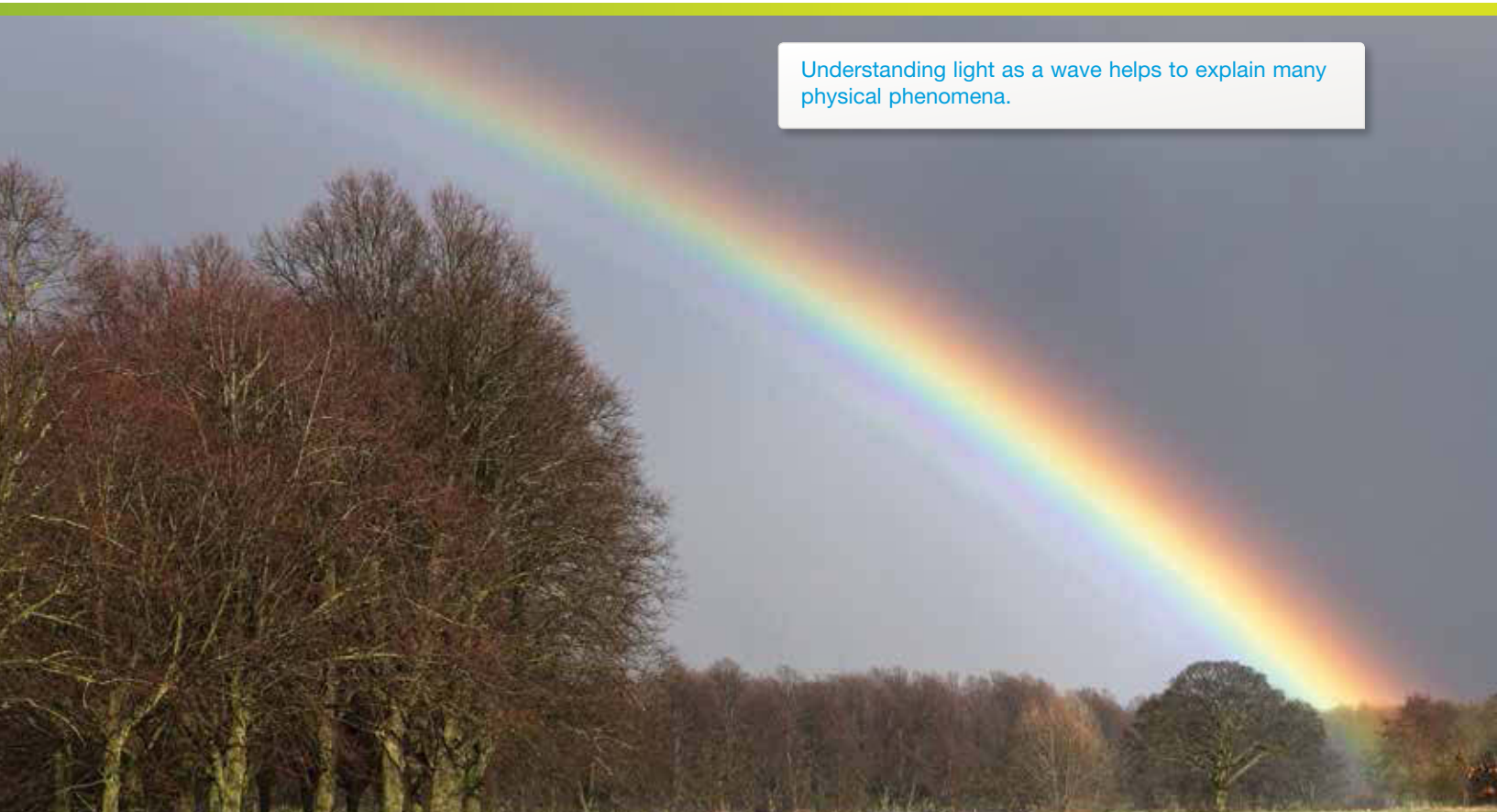



## Digital doc

Investigation 10.1  
Seeing is believing  
doc-18551

**Refraction** is the bending of light as it passes from one medium into another.

## study on

Unit 4

**Refraction**

AOS 1

Concept summary  
and practice

Topic 2

questions

Concept 3

The rays from the fish bend when they enter the air. To the eye, the rays appear to come from a point closer to the surface.

The **angle of refraction** is the angle between a refracted ray and the normal.

## Bending of light

Experience shows that when you are spearing for fish in the shallows you must aim the spear below where the fish appears to be in the water. At the beach or in a pool, people standing in the shallows appear to have shorter legs. Our perception is distorted, but the reason is not apparent.

When we set up a special situation, such as in the figure at right, where a straight rod is placed in a beaker of liquids that do not mix, the idea of change of direction of the light is apparent. This change in direction is called **refraction**.

The ray model can help explain our observations of light. If a fish seems closer to the surface of the water, the ray of light from the fish must have bent. To our eye, the ray seems to be coming from another direction. Given that light can travel both ways along a light path, the fish will see the spear thrower further towards the vertical.



An example of refraction

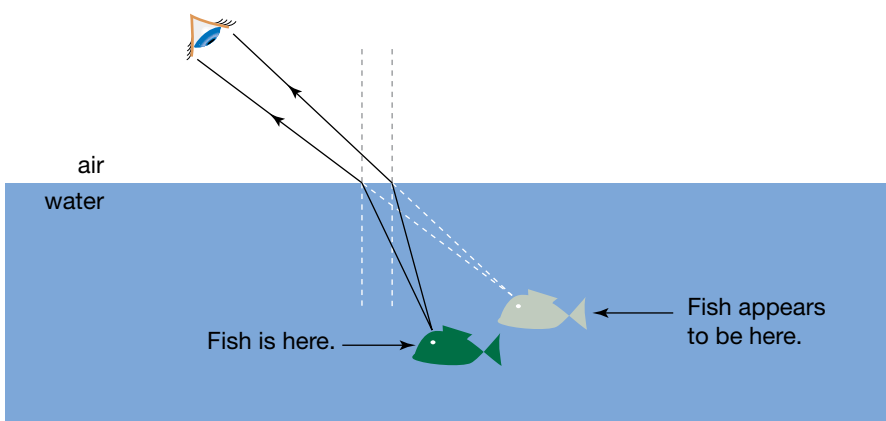

The ray model not only gives us a way of describing our observations of the bending of light, but also of taking measurements. The angle that a ray of light makes with the normal, angle of incidence and **angle of refraction** can be measured and investigated.

## Snell's Law

In 1621, the Dutch physicist Willebrord Snellius (1580–1626), known in the English speaking world as Willebrand Snell, investigated the refraction of light and found that the ratio of the sines of the angles of incidence and refraction was constant for all angles of incidence.

The diagram on page 228 shows how an incident ray is affected when it meets the boundary between air and water. The normal is a line at right angles to the boundary, and all angles are measured from the normal. Some of the light from the incident ray is reflected back into air. The rest is transmitted into the water. The following ratio is a constant for all angles for light travelling from air to water:

$$\frac{\sin \theta_i}{\sin \theta_r} = \text{constant.}$$

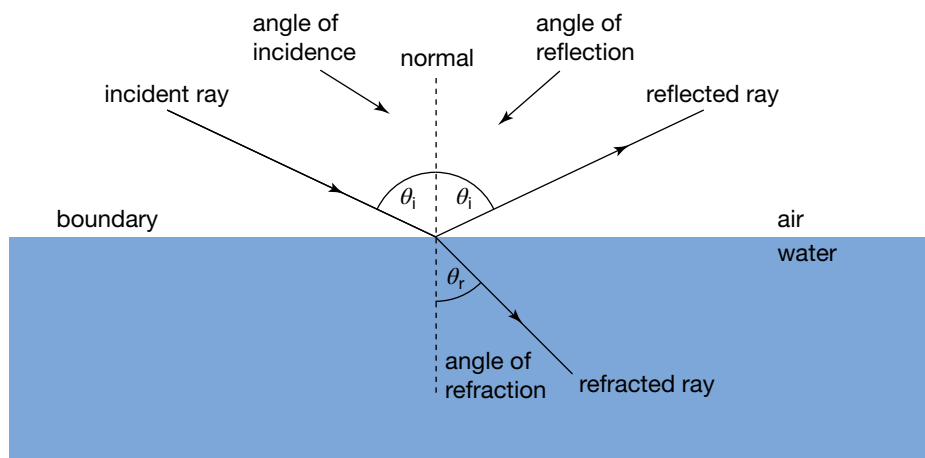

The ratio  $\frac{\sin \theta_i}{\sin \theta_r}$  is constant for all angles for light travelling from air to water.

### AS A MATTER OF FACT

Snell's Law was first discovered by Abu Sa'd Ibn Sahl (c. 940 – c. 1000), a Muslim physicist in the court in Baghdad, in 984. He reported his findings in his book *On burning mirrors and lenses*. Ibn Sahl used the relationship to design a shape for lenses that overcame the problem of spherical aberration. Ptolemy (c. 100 – c. 170), a Greco-Egyptian mathematician, had investigated refraction much earlier, compiling a table of angles for light travelling from air into water.

Snell repeated his experiments with different substances and found that the ratio was still constant, but it had a different value. This suggested that different substances bend light by different amounts. (Remember that some light is always reflected.)

In fact, there is a different ratio for each pair of substances (for example air and glass, air and water). A different ratio is obtained for light travelling from water into glass. The value of the ratio is called the **relative refractive index** because it depends on the properties of two different substances.

**TABLE 10.1** Values for absolute refractive index

Material	Value
Vacuum	1.000 0
Air at 20°C and normal atmospheric pressure	1.000 28
Water	1.33
Perspex	1.49
Quartz	1.46
Crown glass	1.52
Flint glass	1.65
Carbon disulfide	1.63
Diamond	2.42

The bending of light always involves light travelling from one substance to another. It is not possible to find the effect of a particular substance on the deflection of light without adopting one substance as a reference standard. Once you have a standard, every substance can be compared with it. A natural standard is a vacuum — the absence of any substance. The **absolute refractive index** of a vacuum is given the value of one. From this, the absolute refractive index of all other substances can be determined. Some examples are given in table 10.1. (The word 'absolute' is commonly omitted and the term 'refractive index' usually refers to the absolute refractive index.)

The refractive index is given the symbol  $n$  because it is a pure number without any units. This enables a more useful restatement of Snell's Law, for example:

$$n_{\text{air}} \sin \theta_{\text{air}} = n_{\text{water}} \sin \theta_{\text{water}}$$

**Relative refractive index** is a measure of how much light bends when it travels from any one substance into any other substance.

The **absolute refractive index** of a substance is the relative refractive index for light travelling from a vacuum into the substance. It is commonly referred to as the refractive index.

### eBook plus

**eLesson**

Refraction of light and Snell's Law  
eles-0037

**Interactivity**

Refraction of light and Snell's Law  
int-0056

More generally this would be expressed as follows:

$$n_1 \sin \theta_1 = n_2 \sin \theta_2.$$

A graphical depiction of Snell's Law for any two substances. Note that the light ray has no arrow, because the relationship is true for the ray travelling in either direction.

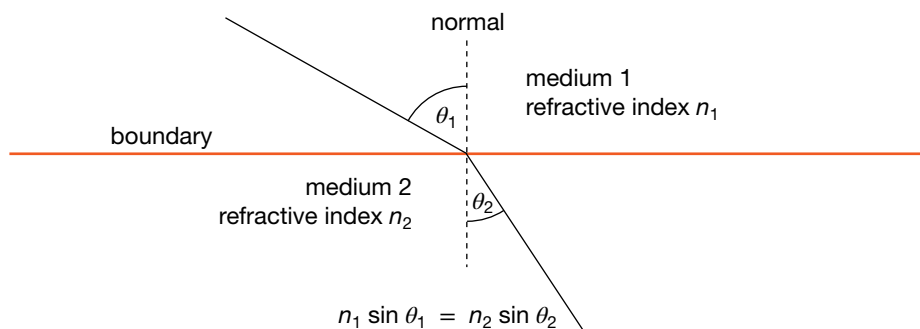

### Sample problem 10.1

A ray of light strikes a glass block of refractive index 1.45 at an angle of incidence of  $30^\circ$ . What is the angle of refraction?

**Solution:**  $n_{\text{air}} = 1.0$ ,  $\theta_{\text{air}} = 30^\circ$ ,  $n_{\text{glass}} = 1.45$ ,  $\theta_{\text{glass}} = ?$

$$1.0 \times \sin 30^\circ = 1.45 \times \sin \theta_{\text{glass}} \quad (\text{substitute values into Snell's Law})$$

$$\sin \theta_{\text{glass}} = \frac{\sin 30^\circ}{1.45} \quad (\text{divide both sides by 1.45, the refractive index of glass})$$

$$= 0.3448 \quad (\text{calculate value of expression})$$

$$\Rightarrow \theta_{\text{glass}} = 20.17^\circ \quad (\text{use inverse sine to find the angle whose sine is 0.3448})$$

$$\Rightarrow \theta_{\text{glass}} = 20^\circ \quad (\text{round off to two significant figures})$$

### Revision question 10.1

A ray of light enters a plastic block at an angle of incidence of  $40^\circ$ . The angle of refraction is  $30^\circ$ . What is the refractive index of the plastic?

### AS A MATTER OF FACT

Light can be bent by a strong gravitational field, such as that near the Sun. The gravitational field can act like a convex lens. Light from a distant star that is behind and blocked by the Sun bends around the Sun so that astronomers on Earth see an image of the star to the side of the Sun.

## Limitations of the ray model

So far in this chapter we have used the ray model to describe how light is refracted. Ray diagrams illustrate Snell's Law and have allowed us to visualise a range of optical phenomena such as mirages and to develop technologies such as optical fibres. However, the ray model, which views light as a pencil thin beam, does not offer an explanation of *why* light refracts. More sophisticated models are needed to provide an explanation for refraction, and in doing so they suggest further experiments to investigate the properties of light more deeply, and to develop new technologies.

Two very different models of light were developed in the seventeenth century — one by Sir Isaac Newton (1642–1727) in England and the other by Christiaan Huygens (1627–1695) in Holland.

Huygens proposed that light travelled outwards from a source like circular ripples on a pond.



Newton's model was described as a 'particle model'. In his model, light consists of a stream of tiny, mass-less particles he called corpuscles. The particles stream from a light source like water from a sprinkler.

Huygens proposed a wave model of light, where light travels in a similar way to sound and water waves. Light leaves a source in the same way that water ripples move out from a dropped stone. The disturbance of the water surface travels outwards from the source.

### How do the two models explain the properties of light?

#### How light travels

*Newton's particle model:* Once ejected from a light source the particles continue in a straight line until they hit a surface.

*Huygens's wave model:* Huygens proposed a basic principle: 'Every point in the wavefront is a source of a small wavelet. The new wavefront is the envelope of all the wavelets.'

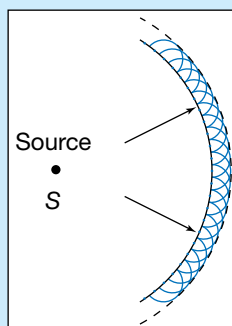

Every point in the wavefront is a source of a small wavelet. The new wavefront is the envelope of all the wavelets.

#### Reflection of light

*Newton's particle model:* As particles approach a surface they are repelled by a force at the surface that slows down and reverses the normal component of the particle's velocity, but does not change its tangential component. The particle is then reflected from the surface at an angle equal to its angle of approach. The same process happens when a billiard ball hits the cushion.

**eBookplus**

**Weblink**

Huygens's principle applet

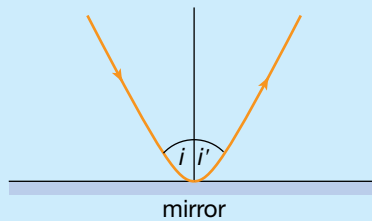

Newton's particle model of reflection

**Huygens's wave model:** As each part of the wavefront arrives at the surface, it produces a reflected wavelet. The new wavelets overlap to produce the next wavefront, which is travelling away from the surface at an angle equal to its angle of approach.

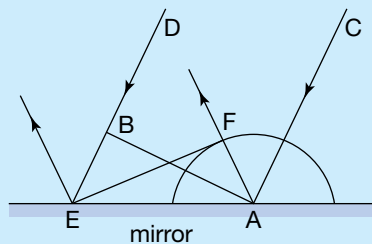

The wave model of reflection. C and D are parallel, incoming rays. AB is the wavefront. When A hits the mirror a circular wavelet is produced. By the time B has reached the mirror at E, the reflected wavelet has travelled out to F. The line EF is the reflected wavefront.

### Refraction of light

**Newton's particle model:** In approaching a denser medium, the particles experience an attractive force which increases the normal component of the particle's velocity, but does not affect the tangential component. This has the effect of changing the direction of the particles, bending them towards the normal where they are now travelling faster in the denser medium. Snell's Law can be explained by this model.

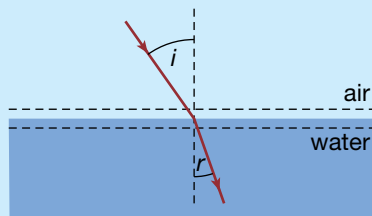

The particle model of refraction. The particles are pulled towards the denser medium, resulting in a change in direction.

**Huygens's wave model:** When the wavefront meets a heavier medium the wavelets do not travel as fast as before. This causes the wavefront to change direction. In this case the wavefront bends towards the normal when it enters a medium where the wave is slowed down. Snell's Law can be explained by this model.

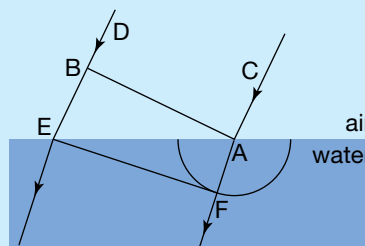

The wave model of refraction. C and D are parallel, incoming rays. AB is the wavefront. When A hits the surface a circular wavelet of slower speed and so smaller radius is produced. By the time B has reached the surface at E, the refracted wavelet has only gone as far as F. The line EF is the refracted wavefront, heading in a direction bent towards the normal compared to the incoming wavefront, AB.

### eBookplus

#### Digital docs

Investigation 10.2  
Refraction of particles

doc-18552

Investigation 10.3  
Refraction of waves

doc-18553

(continued)

### A point of difference

Now, with these two explanations of refraction, there is a clear distinction between the two models. When light bends towards the normal as it enters water (a denser medium), the particle model says it is because light travels faster in water (the denser medium), whereas the wave model says it is because the light is travelling slower.

In the seventeenth century they did not have the technology to measure the speed of light in water. However, the particle model became the accepted explanation, partly because of Newton's status, and partly because Huygens's principle suggested that light should bend around corners like sound, and there was no evidence of this at the time. (Newton himself actually thought that the particles in his model needed to have some wave-like characteristics to explain some of his other observations of light and colour.)

### New evidence emerges

In 1802, Thomas Young (1773–1829) showed that in fact light could bend around an edge. This is covered in some detail on pages 239–42. This was convincing evidence for the wave model, as the particle model had no mechanism to explain how particles could bend around a corner. However, the status of Newton was such that not all were convinced by Young's results. It was suggested that conclusive evidence would be to measure the speed of light in water and see if it was faster or slower than that in air. Jean Bernard Leon Foucault (1819–1868) and Hippolyte Fizeau (1819–1896) competed to measure the speed of light in water; in 1850, both of them showed that light was slower in water, though Foucault won by seven weeks.

## Speed of light in glass

Foucault and Fizeau's results, along with the work of Augustin-Jean Fresnel (1788–1827) (pronounced 'fray-NEL'), showed that the speed of light in water was less than the speed of light in air. This allowed scientists to determine the physical meaning of the refractive index:

$$\text{absolute refractive index of water} = \frac{\text{speed of light in a vacuum}}{\text{speed of light in water}}$$

where

$$\text{speed of light in a vacuum} = 3.0 \times 10^8 \text{ m s}^{-1}.$$

The above formula can be re-arranged to give

$$n_{\text{water}} \times v_{\text{water}} = c$$

where  $c$  = the speed of light in a vacuum

$v_{\text{water}}$  = the speed of light in water.

Similarly for glass,  $n_{\text{glass}} \times v_{\text{glass}} = c$ , which means  $n_{\text{glass}} \times v_{\text{glass}} = n_{\text{water}} \times v_{\text{water}}$ , or as a general relationship:

$$n_1 v_1 = n_2 v_2 \text{ for any two materials.}$$

### Sample problem 10.2

- The refractive index of glass is 1.5. How fast does light travel in glass?
- Use the answer to (a) to determine the speed of light in water.

**Solution:** (a) 
$$1.5 = \frac{3.0 \times 10^8}{(\text{speed of light in glass})}$$

$$\Rightarrow \text{speed of light in glass} = \frac{3.0 \times 10^8}{1.5} \text{ (rearrange formula to get the unknown by itself)}$$

$$= 2.0 \times 10^8 \text{ m s}^{-1}.$$

(b) 
$$1.5 \times 2.0 \times 10^8 \text{ m s}^{-1} = 1.33 \times v_{\text{water}}$$

$$v_{\text{water}} = \frac{1.5 \times 2.0 \times 10^8 \text{ m s}^{-1}}{1.33}$$

$$v_{\text{water}} = 2.3 \times 10^8 \text{ m s}^{-1}$$

### eBookplus

#### Digital doc

Investigation 10.4  
Using apparent depth to determine the refractive index

doc-18554

### Revision question 10.2

- (a) How fast does light travel in diamond?  
(b) Use the answer to (a) to determine the speed of light in carbon disulfide.

## Total internal reflection and critical angle

Light can play some strange tricks. Many of these involve refraction away from the normal and the effect on light of a large increase in the angle of incidence.

### study on

Unit 4

AOS 1

Topic 2

Concept 4

#### Total internal reflection

Concept summary and practice questions



There are no mirrors in a fish tank but strange reflections can be seen. It appears that light is being reflected off the side of the fish tank and the water surface.

It has already been mentioned that some light is reflected off a transparent surface, while the rest is transmitted into the next medium. This applies whether the refracted ray is bent towards or away from the normal. However, a

The **critical angle** is the angle of incidence for which the angle of refraction is  $90^\circ$ . The critical angle exists only when light passes from one substance into a second substance with a lower refractive index.

**Total internal reflection** is the total reflection of light from a boundary between two substances. It occurs when the angle of incidence is greater than the critical angle.

special situation applies when the refracted ray is bent away from the normal. This is illustrated in the figure below. As the angle of incidence increases, the angle of refraction also increases. Eventually the refracted ray becomes parallel to the surface and the angle of refraction reaches a maximum value of  $90^\circ$  (see figure (b)). The corresponding angle of incidence is called the **critical angle**. If the angle of incidence is increased beyond the critical angle, all the light is reflected back into the water, with the angles being the same. This phenomenon is called **total internal reflection** (see figure (c)).

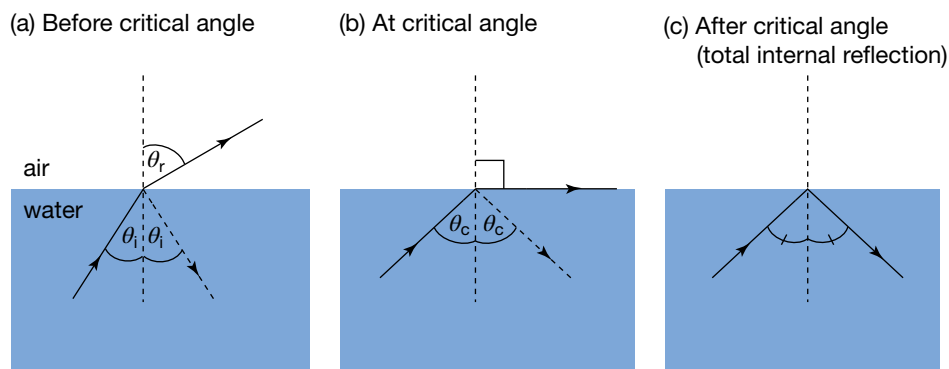

Three stages of refraction leading to total internal reflection

The critical angle can be calculated using Snell's Law,  $n_1 \sin(\theta_c) = n_2 \sin(90^\circ)$ .

### Sample problem 10.3

What is the critical angle for water given that the refractive index of water is 1.3?

**Solution:**  $n_{\text{air}} = 1.0, \theta_{\text{air}} = 90^\circ, n_{\text{water}} = 1.3, \theta_{\text{water}} = ?$

$1.0 \times \sin 90^\circ = 1.3 \times \sin \theta_{\text{water}}$  (substitute data into Snell's Law)

$\Rightarrow \sin \theta_{\text{water}} = \frac{\sin 90^\circ}{1.3}$  (rearrange formula to get the unknown by itself)

$= 0.7692$  (determine sine values and calculate expression)

$\Rightarrow \theta_{\text{water}} = 50.28^\circ$  (use inverse sine to find angle)

$\theta_{\text{water}} = 50^\circ$  (round off to two significant figures)

### Revision question 10.3

A glass fibre has a refractive index of  $x$  and its cladding has a refractive index of  $y$ . What is the critical angle in the fibre?

**Total internal reflection** is a relatively common atmospheric phenomenon (as in mirages) and it has technological uses (for example, in optical fibres).

## Mirages

There are several types of mirage that can be seen when certain atmospheric conditions enable total internal reflection to occur. These mirages appear because the refractive index of air decreases with temperature.





Mirages such as this are common on hot, sunny days.

A common type of mirage occurs in the desert or above a road on a sunny day. As displayed in the figure below, at ground level the air is hot (A) with a refractive index close to 1 (B). As height increases, the temperature of the air decreases (C) and its refractive index increases (D).

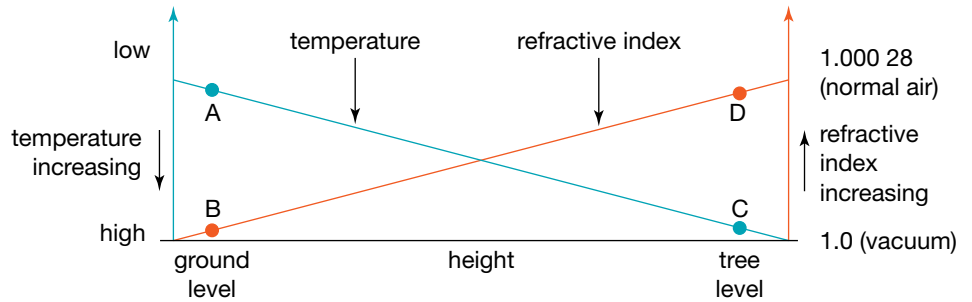

Temperature and refractive index profiles for the mirage phenomenon

Rays of light from a car, for example, go in all directions. The air above the ground can be considered as layers of air. The closer to the ground, the higher the temperature and the lower the refractive index. As a ray moves into hotter air, it bends away from the normal. After successive deflections, the angle of incidence exceeds the critical angle for air at that temperature and the ray is totally internally reflected. As the ray emerges, it follows a similar path, refracting towards the normal as it enters cooler air. An image of the car can be seen below street level (see the figure below). The mirage is upside down because light from the car has been totally internally reflected by the hot air close to the road surface.

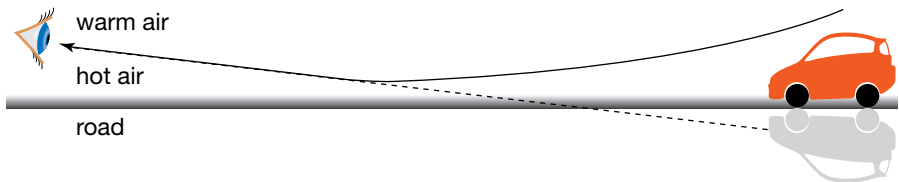

The mirage of the car appears upside down due to total internal reflection in the hot air close to the ground.

**eBookplus**

**Weblink**  
Mirages and more

Another mirage that depends on layers of air at different temperatures is known as the 'Fata Morgana' in which vertical streaks, like towers or walls, appear. This occurs where there is a temperature inversion — very cold at ground level and warmer above — and very stable weather conditions.

The phenomenon is named after Morgan le Fay (Fata Morgana in Italian) who was a fairy and half-sister to King Arthur of the Celtic legend. She used mirages to show her powers and, in the Italian version of the legend, lived in a crystal palace under the sea. The mirage is often seen in the Strait of Messina and over Arctic ice. As shown in the figure below, the light rays from a distant point are each refracted by the different layers of air, arriving at different angles to the eye. The effect is that the point source (P) becomes a vertically extended source, like a tower or wall.

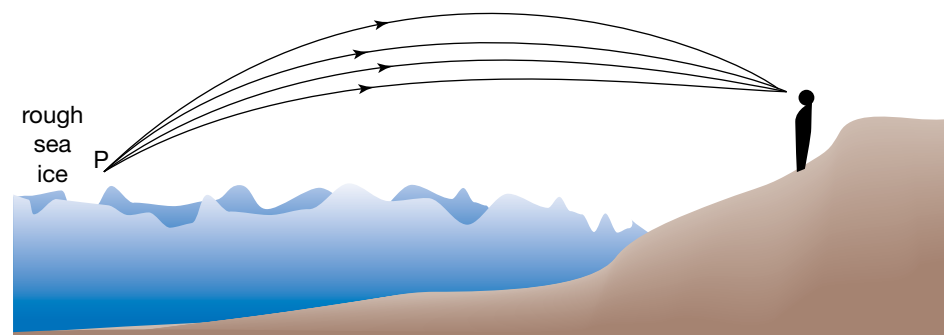

Ray paths for the Fata Morgana

An example of the Fata Morgana over an ice field in the Arctic Ocean off the coast of Svalbard. The conditions that encourage the Fata Morgana are particularly common in the polar regions over ice.



An **optical fibre** is a thin tube of transparent material that allows light to pass through without being refracted into the air or another external medium.

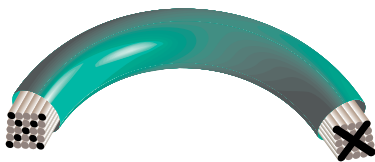

A bundle of optical fibres. Each fibre in the bundle carries its signal along its length. If the individual fibres remain in the same arrangement, the bundle will emit an image of the original object.

## Optical fibres

Another example of total internal reflection is in the important technological application of **optical fibres**. Optical fibres have become a feature of modern life. A thin, flexible cable containing an optical fibre can be placed inside a person's body to transmit pictures of the condition of organs and arteries, without the need for invasive surgery. The same can be done in industry when there is a problem with complex machinery.

Optical fibres are also the basis of the important telecommunications industry. They allow high quality transmission of many channels of information in a small cable over very long distances and with negligible signal loss.

An optical fibre is like a pipe with a light being shone in one end and coming out of the other. An optical fibre is made of glass which is about 10 micrometres ( $10 \times 10^{-6}$  m) thick. Light travels along it as glass is transparent, but the fibre needs to be able to turn and bend around corners. The optical fibre is designed so that any ray meeting the outer surface of the glass fibre is totally internally reflected back into the glass. As shown in the figure below, the light ray meets the edge of the fibre at an angle of incidence greater than the critical angle and is reflected back into the fibre. In this way, nearly all of the light that enters the fibre emerges at the other end.

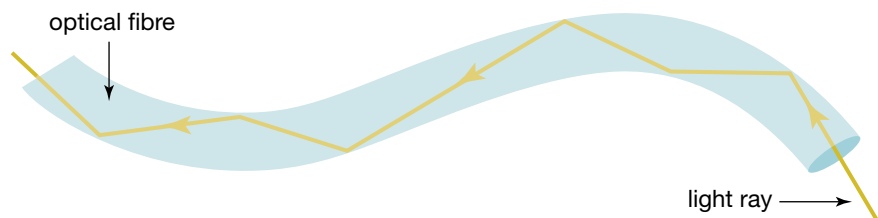

A light ray travels along an optical fibre through total internal reflection.

### eBook plus

**Weblink**  
Fibre optics

If the glass fibre is exposed to the air, the critical angle for light travelling from glass to air is  $42^\circ$ , which is quite small. Any angle of incidence greater than this angle will produce total internal reflection. If the fibre is very narrow, this angle is easily achieved.

However, in both medical and telecommunication uses, fibres are joined in bundles with edges touching. The touching would enable light rays to pass from fibre to fibre, confusing the signal. To overcome this, a plastic coating is put around the glass to separate the glass fibres. The total internal reflection occurs between the glass and the plastic. The critical angle for light travelling

from glass to plastic is  $82^\circ$ . This value presents a problem because light meeting the edge of the glass at any angle less than  $82^\circ$  will pass out of the fibre.

This has implications for the design of the optical fibre and the beam of light that enters the fibre. The fibre needs to be very narrow and the light entering the fibre has to be a thin beam with all the rays parallel.

Light rays entering the fibre at too sharp an angle are refracted out of the fibre.

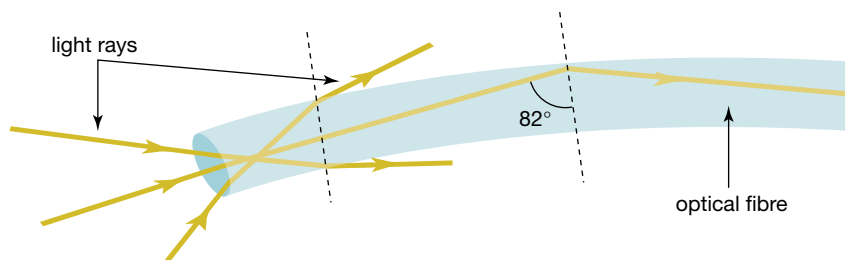

## Dispersion: producing colour from white light

**Dispersion** is the separation of light into different colours as a result of refraction.

White light can be separated into colours using a narrow beam of light and a glass triangular prism. This phenomenon is called **dispersion**. It was first analysed in this way by Isaac Newton in 1666, although René Descartes had sought an explanation for rainbows in 1637 by working with a spherical glass flask filled with water.

As light enters a triangular glass prism, it is refracted towards the normal. It then travels through the prism to the other side where it is refracted away from the normal, because the light is re-emerging into the air.

### eBookplus

#### Digital doc

Investigation 10.5  
Separating colours

doc-18555

#### Interactivity

Spreading the spectrum

int-6609

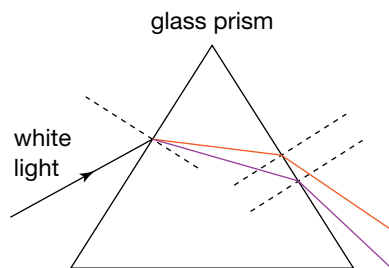

The colours in white light separate as they enter the glass and separate even more when they leave. At each edge, the violet is deflected more than the red.

The colours spread as they enter the glass and travel on different paths through the triangular prism. They are spread even more as they leave the glass. Violet is bent the most and red the least. The order of the colours, from the colour that bends least to the colour that bends most, is: red, orange, yellow, green, blue, indigo, violet.

A spectrum of colours is produced when white light is passed through a prism. The red light is deflected the least and each colour in the spectrum is deflected progressively more.

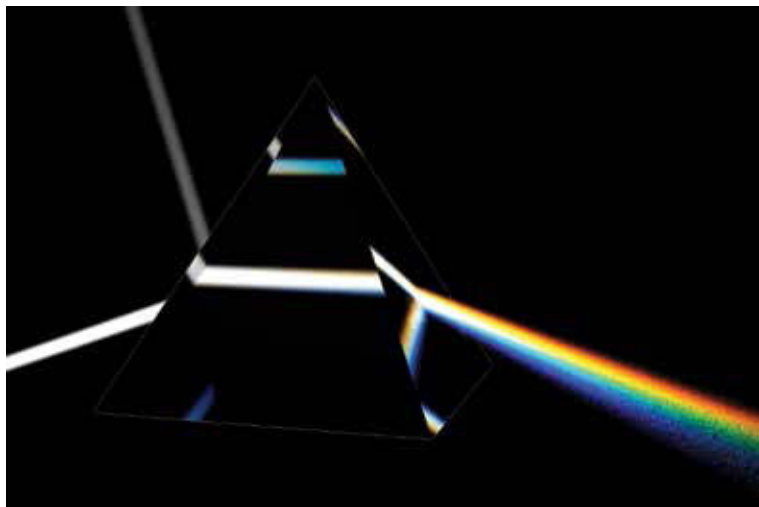

Each colour has a different angle of refraction. This means that the glass has a different refractive index for each colour. This can be expressed as a statement of Snell's Law as follows:

$$n_{\text{air}} \sin \theta_i = n_{\text{gl (red)}} \sin \theta_{\text{red}} = n_{\text{gl (violet)}} \sin \theta_{\text{violet}}$$

For example, as shown in the figure below, violet light is bent more than red, so  $\theta_{\text{violet}}$  is smaller than  $\theta_{\text{red}}$ . This means that the refractive index of glass for violet light is greater than that for red light. This is also true for other materials (see table 10.2).

### study on

#### Unit 4 Dispersion

AOS 1 Concept summary

Topic 2 and practice questions

Concept 5

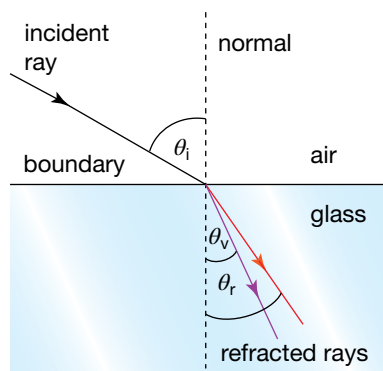

The angle of refraction for violet light is smaller than that for red light. This means that the refractive index of the glass is different for different colours. For violet it must be greater than that for red.

### eBook plus

#### eModelling

Using a spreadsheet to explore refraction through a prism

doc-0058

TABLE 10.2 Refractive index values vary for different coloured light

Colour	Index of refraction			
	Crown glass	Flint glass	Diamond	Water
Red	1.514	1.571	2.410	1.331
Yellow	1.517	1.575	2.418	1.333
Deep blue	1.528	1.594	2.450	1.340

## PHYSICS IN FOCUS

### Sparkling physics

Diamonds are cut by a gem-maker so that when light enters the diamond it strikes a few faces at angles greater than the critical angle. This maximises the light path and increases the separation of the colours that occurred when the light first entered the diamond.

The appearance of white paint as white is actually due to the large amount of refraction and dispersion created by the titanium dioxide particles it contains. A large percentage of the light that hits a white surface is reflected back, the colours go in all directions and hence the surface appears white.

# Rainbows

Rainbows are a common example of the dispersion of light. However, they are not seen only in the sky. You can also see a rainbow when you use a garden hose. Three conditions are necessary for a rainbow to be visible:

- the Sun
- some water droplets in the air
- an observer.

The usual arrangement of these three elements for a rainbow to be seen is to have the Sun behind the observer and water in the air in front of the observer. The water drops separate the colours in a similar way to that which occurs with the glass prism. The big difference is that, before the colours emerge from the water droplet, they are reflected from the opposite surface of the droplet.

## eBookplus

### Weblink

Formation of a rainbow applet

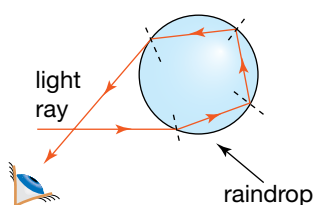

A light ray enters the bottom of the raindrop, is reflected twice off the wall of the raindrop, then emerges. The ray enters the eye at a higher angle than the primary rainbow. The colours are spread as they enter the raindrop and grow further apart the longer they are in the raindrop.

Each droplet of water in the air spreads the colours. Person A sees a rainbow from raindrops in the air between droplet 2 and droplet 3. Person B sees a rainbow between droplet 1 and droplet 2.

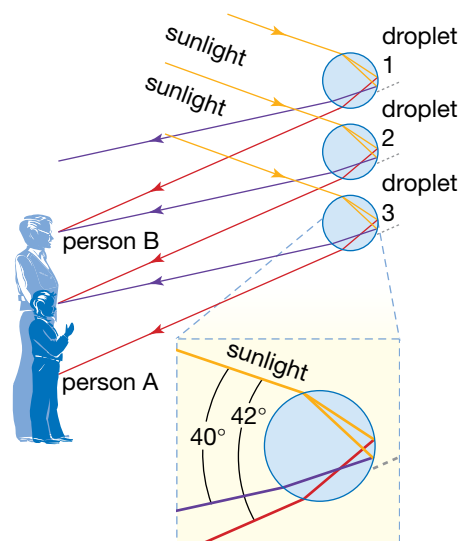

When you see a rainbow, each colour is coming from a separate raindrop in the sky. If the red light from a raindrop is entering your eye, then the violet light from that raindrop is going over your head to someone else. Each person sees his or her own personal rainbow. Your rainbow depends on raindrops in the sky being at a particular point so that the angle between you, the Sun and the raindrops is approximately  $42^\circ$ . The rainbow is not an image in the sky that everyone can see.

When the sky is very dark, a second, fainter rainbow may be visible on the outside of the bright one. This is due to the sunlight entering higher raindrops at the bottom and reflecting off the inside of the drop twice before emerging into the air.

## Young's experiment

Thomas Young (1773–1829) was keenly interested in many things. He has been called 'the last man who knew everything'. He was a practising surgeon as well as a very active scientist. He analysed the dynamics of blood flow, explained the accommodation mechanism for the human eye and proposed the three-receptor model for colour vision. He also made significant contributions to the study of elasticity and surface tension. His other interests included deciphering ancient Egyptian hieroglyphics, comparing the grammar and vocabulary of over 400 languages, and developing tunings for the twelve notes of the musical octave. Despite these many interests, the wave explanation of the nature of light was of continuing interest to him.

## eBookplus

### eLesson

Young's experiment  
(interference effects with white light)  
eles-0027

### Interactivity

Young's experiment  
(interference effects with white light)  
int-0051

## study on

Unit 4

Results and wave model explanation

AOS 1

Topic 3

Summary screen and practice questions

Concept 1

## study on

Unit 4

AOS 1

Topic 3

Concept 2



See more

Young's experiment

Young had already built a ripple tank to show that the water waves from two point sources with synchronised vibrations show evidence of interference. He was keen to see if he could observe interference with two beams of light. He held a fine hair close to his eye while staring past it at a distant candle. The light from the candle flame passed on both sides of the hair to reach his eyes. He did not notice a scattering of light in all directions as predicted by the particle model. Instead, a beautifully coloured pattern of bands parallel to the hair spread out across his view of the candle. Young's interpretation of what he saw was that light behaved like waves as it spread out from the candle.

*It occurred to me that their cause must be sought in the interference of two portions of light, one reflected from the fibre, the other bending round its opposite side, and at last coinciding nearly in the direction of the former portion.*

Young described this and other experiments in lectures at the Royal Institution in London in 1801 and 1802. He did not convince his audience! His listeners were reluctant to remove their confidence from the particle model that Newton apparently supported. Young was determined to produce quantitative evidence of the phenomenon that he had observed. He analysed the published results of similar experiments performed by Newton and made further measurements of his own.

In one of his experiments Young made a small hole in a window blind. He placed a converging lens behind the hole so that the cone of sunlight became a parallel beam of light. He then allowed light from the small hole to pass through two pinholes that he had punctured close together in a card. On a screen about two metres away from the pinholes he again noticed coloured bands of light where the light from the two pinholes overlapped. The diagram below shows Young's experimental arrangement.

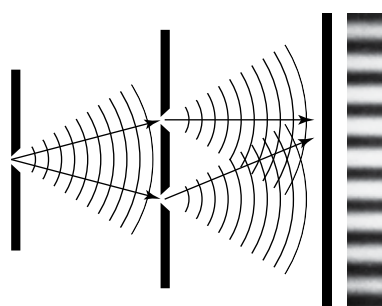

Light waves in Young's experiment

Two waves are **coherent** if there is a constant relative phase between them.

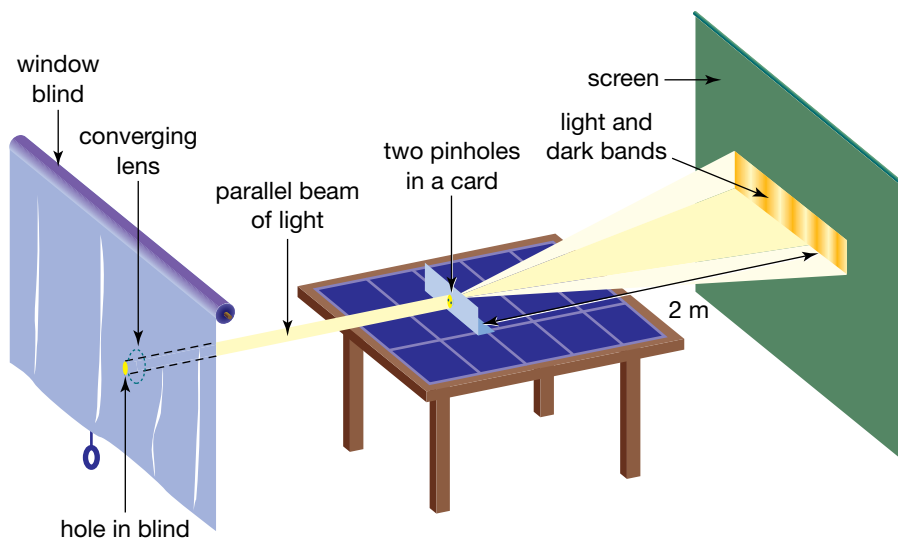

Young's experiment

Young deliberately had just one source, the hole in the blind, because he wanted the one wavefront to arrive at the two pinholes, so that light coming through one pinhole would be synchronised with the light coming through the other pinhole. Today we would describe light coming from the two pinholes as **coherent**. In the language of the previous chapter, the two waves are in phase. If Young had used two separate sources of light, one for each pinhole, their light would have been incoherent, with a random relationship between the light coming from the two pinholes and no discernible pattern on the screen.

A light pattern produced by a modern performance of Young's experiment



### eBook plus

#### Weblink

The atomic lab:  
wave interference

**Path difference** is the difference between the lengths of the paths from each of two sources of waves to a point.

## Interpreting Young's experiment

Young used the wave model for light to analyse his observations. Each hole in the window blind is a source of spherical waves. When these waves pass through the pinholes, each pinhole becomes a source of spherical waves. Waves from the two pinholes overlap on the screen, and their effects add together to produce the pattern. In reaching a particular point on the screen, waves have travelled from the source along two alternative routes, through one pinhole or the other. The difference between the lengths of the two paths is called the **path difference**. If the path difference results in the crests of the wave from one pinhole always meeting the troughs of the wave from the other pinhole (that is, exactly out of phase) then destructive interference occurs and that place on the screen is a dark band. Destructive interference occurs when the path difference is a whole number, minus one half, multiplied by the wavelength of the light:  $(n - 0.5)\lambda$  where  $n = 1, 2, \dots$  is the number of bright bands from the central bright band. A bright band occurs when, in spite of a path difference, the waves are in phase: crests reinforcing crests and troughs meeting troughs.

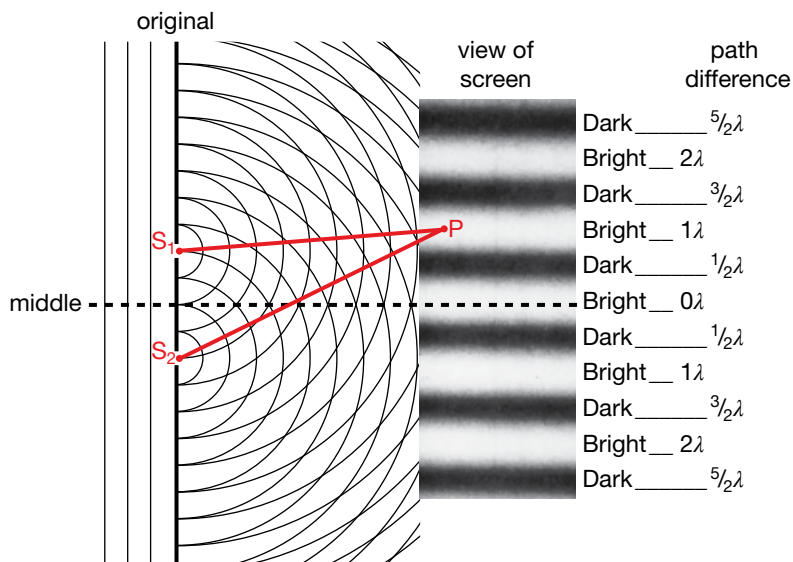

The wave model describes the two-slit interference pattern. Maximum intensity occurs for the maximum amplitude light wave, because of constructive interference. At P,  $S_2P - S_1P = \lambda$ .

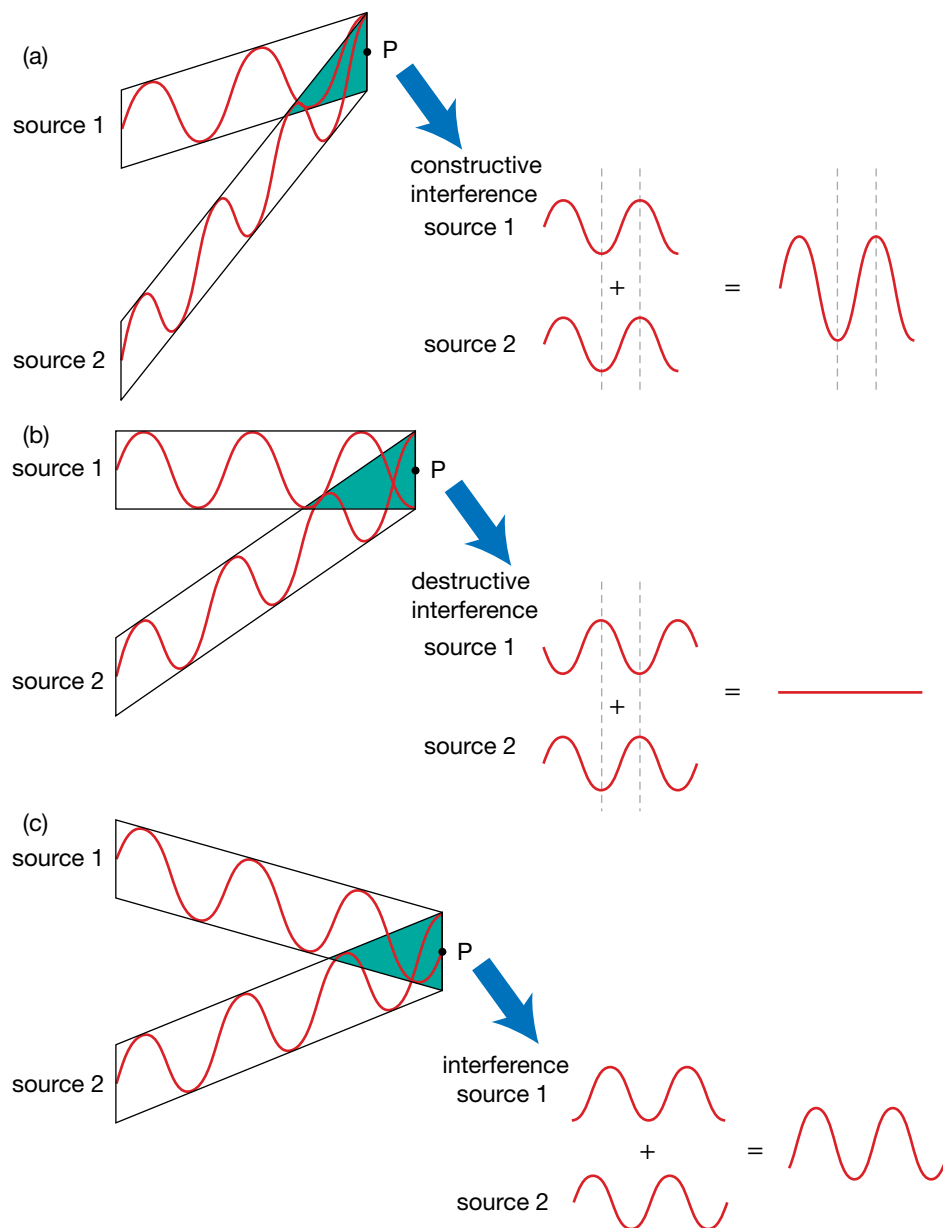

### study on

Unit 4

**General behaviour**

AOS 1

Summary screen and practice questions

Topic 3

Concept 2

(a) Constructive interference of waves arriving in phase, (b) destructive interference of waves arriving exactly out of phase, and (c) interference of two waves slightly out of phase

### study on

Unit 4

AOS 1

Topic 3

Concept 2

**Do more**

Young's experiment (interference effects with white light)

This constructive interference occurs when the path difference is a whole number multiple of the wavelength of the light,  $n\lambda$ , again where  $n = 1, 2, \dots$  is the number of bright bands from the central bright band.

Think about performing Young's experiment with a light source emitting light of only one wavelength, say 600 nm ( $6 \times 10^{-7}$  m) in the richly yellow part of the spectrum. Constructive interference will occur if the path difference between the two routes to the screen is 0, 600 nm, 1200 nm, 1800 nm,  $\dots n \times 600$  nm, where  $n$  is an integer. However, if the path difference is 300 nm, 900 nm, 1500 nm  $\dots (n - 0.5) \times 600$  nm, where  $n$  is an integer, then there will be destructive interference.



### Sample problem 10.4

Red light of wavelength 640 nm is passed through a pair of slits to produce an interference pattern.

- What is the path difference for the third bright band from the central bright band?
- Consider the second dark band from the central bright band. How much further is  $S_2$  than  $S_1$  from the second dark band?
- Red light is replaced with purple light. What happens to the interference pattern?

- Solution:**
- The third bright band has a path difference of  $3\lambda$ . Thus the path difference is  $3 \times 640 = 1920$  nm.
  - The second dark band arises because of destructive interference where the path difference is  $\frac{3\lambda}{2}$ . This means  $S_2$  is further away from this dark band than  $S_1$  by a distance:

$$\frac{3\lambda}{2} = \frac{3 \times 640}{2} = 910 \text{ nm.}$$

- The pattern is now purple and because the wavelength for purple light is less than for red light. The pattern is now more compact or compressed.

### Revision question 10.4

A student creates an interference pattern using green light of wavelength 530 nm. The pattern is shown below.

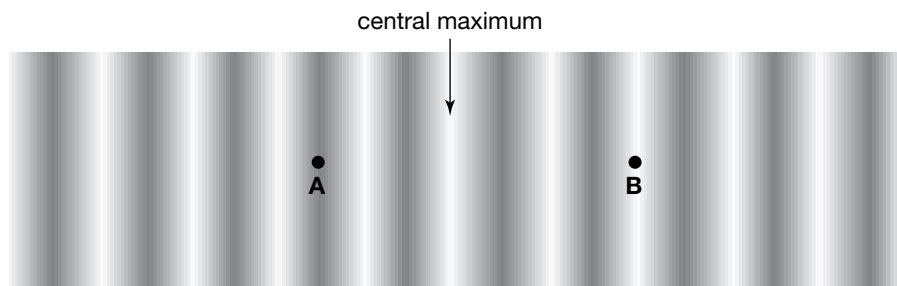

- Calculate the path difference for the points marked A and B.
- The student increases the distance between the two slits. Describe what happens to the pattern.
- She now changes the light source from green to red. Describe what happens to the pattern now.
- Explain why the interference pattern is strong evidence for the wave nature of light.

## Spacing of bands in an interference pattern

The previous section developed expressions relating the path difference to the light and dark bands in an interference pattern. These expressions are important in understanding Young's experiment, but the path difference cannot be measured. What can be measured in this experiment is:

- the separation of the two slits,  $d$
- the wavelength,  $\lambda$
- the distance of the screen from the two slits,  $L$
- the spacing between alternate bands in the pattern (either the bright or dark bands),  $\Delta x$ .

A relationship between these four quantities would be useful. It could be used to calculate the wavelength of an unknown light source from a slide with a known slit separation, or to calculate an unknown slit separation with light of a known wavelength.

If the separation of the two slits,  $d$ , is very much less than the distance  $L$ , then the two lines  $S_1P$  and  $S_2P$  are effectively parallel, as in figure 2 below. Typically  $d$  is about 1 mm and  $L$  is about 2 metres.

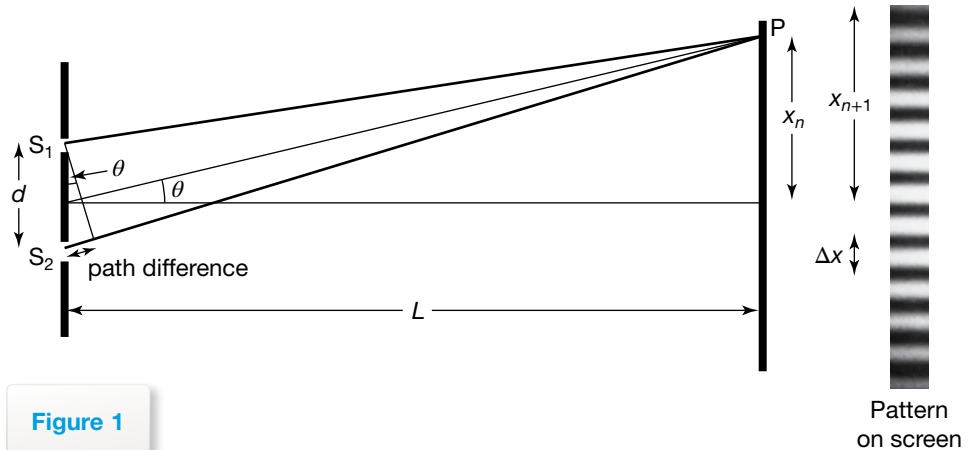

Figure 1

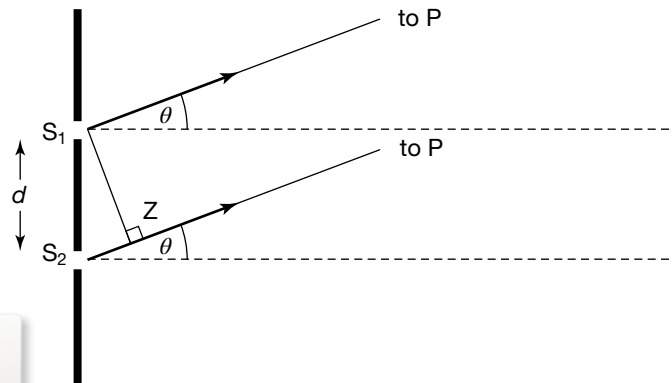

Figure 2

$S_1Z$  is a line drawn across the two light paths at right angles. The distances from  $S_1$  to  $P$  and from  $Z$  to  $P$  will be equal to each other. This means the path difference is  $S_2Z$ . From the right-angled triangle with corners at  $S_1$ ,  $Z$  and  $S_2$ , and a right angle at  $Z$ ,  $\sin \theta = \frac{\text{path difference}}{d}$ , or path difference =  $d \sin \theta$ .

For bright lines,  $d \sin \theta = n\lambda$ , where  $n = 1, 2, 3, \dots$

From figure 1,  $\tan \theta = \frac{x_n}{L}$ , but for small angles less than  $10^\circ$ ,  $\tan \theta$  and  $\sin \theta$  have similar values to within about 1%.

So, for small angles,  $\frac{n\lambda}{d} = \frac{x_n}{L}$ ,

giving  $x_n = \frac{n\lambda L}{d}$ ,

and for  $n + 1$ ,  $x_{n+1} = \frac{(n+1)\lambda L}{d}$ .

The spacing between adjacent bright lines is given by:

$$x_{n+1} - x_n = \Delta x = \frac{\lambda L}{d}.$$

### Sample problem 10.5

Sodium light of wavelength 589 nm is directed at a slide containing two slits 0.500 mm apart. What will be the spacing between the bright bands in the interference pattern on a screen 1.50 m away?

**Solution:**  $\lambda = 589 \text{ nm}$ ,  $L = 1.50 \text{ m}$ ,  $d = 0.500 \times 10^{-3} \text{ m}$ ,  $\Delta x = ?$

$$\begin{aligned}\Delta x &= \frac{\lambda L}{d} \\ &= \frac{5.89 \times 10^{-9} \times 1.50}{0.500 \times 10^{-3}} \\ &= 0.00177 \text{ m} \\ &= 1.8 \text{ mm}\end{aligned}$$

### Revision question 10.5

Interference bands are formed on a screen 2.00 m from a double slit with separation 1.00 mm. The bands are measured to be 1.30 mm apart.

- What is the wavelength of the light?
- What is its colour?
- How would the pattern change if blue light was used?
- How could the experimental design be changed to make it easier to measure the line spacing in the pattern?

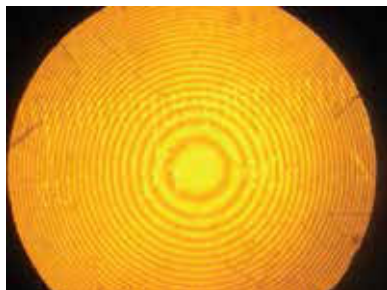

Newton's rings

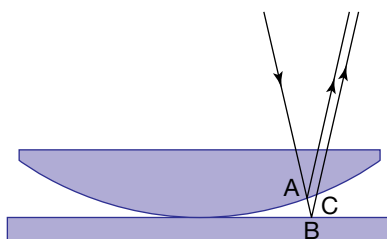

How light creates the effect known as Newton's rings

## Other interference experiments

### Newton's rings

The phenomenon that came to be called Newton's rings was first observed by Robert Hooke in 1664. If a planoconvex lens, that is, a lens that is flat on one side and curved on the other, is placed on a very flat piece of glass, then concentric bands can be observed when you look down from above. With white light, the bands have rainbow edges. In 1717 Isaac Newton observed the bands and used different colours to calculate the thickness of the air space at the first band for each colour. However, he did not see the phenomenon as supporting the wave model of light.

Thomas Young thought the explanation for this phenomenon was interference from light travelling by two different paths. The short path was for the light reflected from the bottom surface of the lens at A; the long path was for the light transmitted at A, then reflected at B and back through the lens at C. The path difference ABC was related to the thickness of the air gap.

Thus, Young was able to measure, for the first time, the wavelengths of the different colours in the visible spectrum. Young also applied this method to the newly discovered 'dark' light and showed that it had a shorter wavelength than violet light. Hence, the 'dark' light became known as 'ultraviolet' light. This led Young to speculate that radiation from hot objects might be of a similar nature but beyond red light in wavelength.

### Fresnel's biprism

In 1818 Augustin-Jean Fresnel refined Young's experimental design using a biprism to produce the effect of a double slit. Fresnel also designed a new lens for use in lighthouses. His design, now called a Fresnel lens, enables the construction of lenses that have the same focal length as standard lenses but are thinner and lighter in weight.

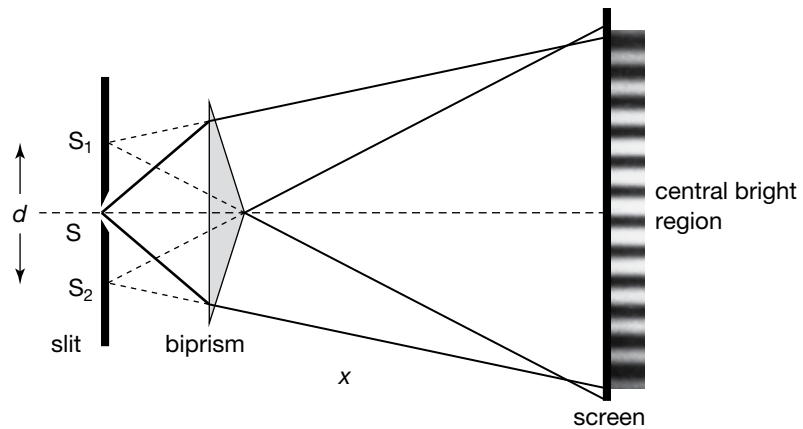

Fresnel's biprism

## Lloyd's mirror

In 1834 Humphrey Lloyd (1800–1881) showed that an interference pattern could also be produced when a point light source was placed at a low angle relative to a glass slab. The path difference between the reflected ray off the slab and the ray that travelled directly to the screen was small enough for constructive and destructive interference to occur. This effect also occurs in underwater acoustics.

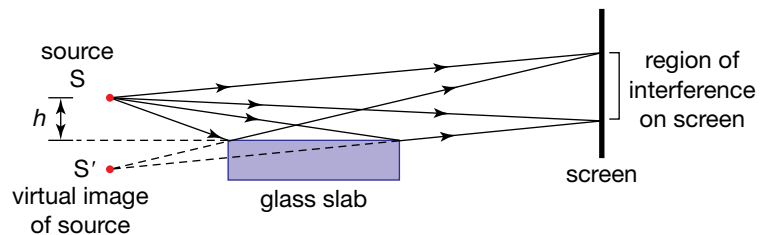

Lloyd's mirror

## Diffraction of light

Chapter 9 describes diffraction as one of the defining properties of waves. However, the word 'diffraction' was coined by Francesco Grimaldi (1618–1663) to describe a specific observation he made of light. He observed that when sunlight entered a darkened room through a small hole, the spot was larger than would be expected from straight rays of light. He also noted that the border of the spot was fuzzy and included coloured fringes. He observed a similar effect when light passed a thin wire or a strand of hair. There is also some evidence that he repeated the experiment with two adjacent holes and observed evidence of cancellation: 'That a body actually enlightened may become obscure by adding new light to that which it has already received.' Grimaldi did not give an explanation for these observations in terms of waves or particles.

Newton was aware of Grimaldi's observation of 'diffraction'. He interpreted it using his particle model, arguing that the observed effect was due to light particles interacting with the edges of the hole as a refraction effect. He argued that if light was a wave, the bending would be much greater. Newton's conclusions on the particle model were enough for scientists even a hundred years later, in Young's time, to doubt any experimental evidence supportive of the wave model.

However, with improving technology, the investigation of the diffraction of light revealed more than just the observation of spreading.

- The pattern had a central bright region with narrower and less bright regions either side.



Diffraction of red light

**study on**

Unit 4 **Diffraction of light**

AOS 2 Summary screen and practice questions

Topic 1

Concept 1

- There was a dark gap between the bright regions.
- The central region was twice as wide as the other regions, which were all about the same size.
- The pattern for red light is more spread out than that for blue light.

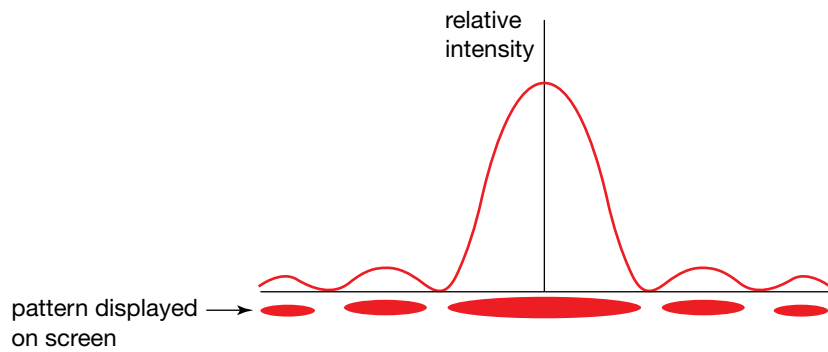
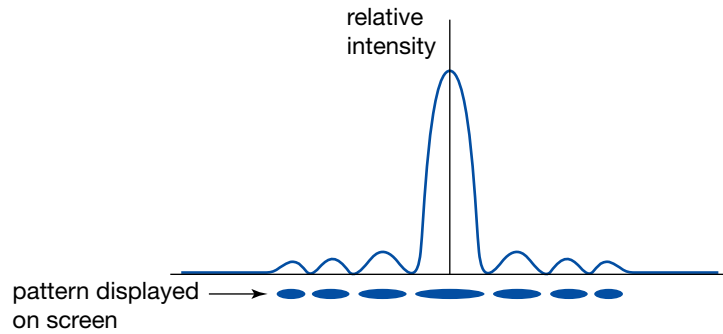

Relative intensity and diffraction patterns for (a) blue light and (b) red light

**study on**

Unit 4

AOS 2

Topic 1 **Do more**

Concept 1 **Diffraction with a single slit**

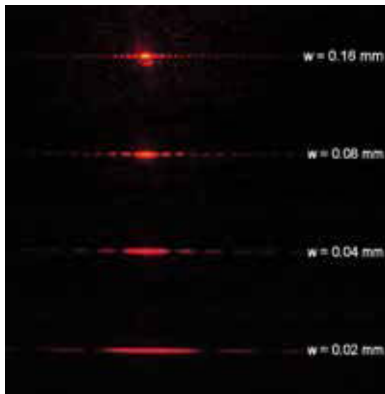

Diffraction patterns change with gap width. As the gap width gets smaller, coming down the figure, the pattern spreads out more.

The pictures and graphs above of the diffraction of light confirm that light satisfies the same relationships as other waves, that is:

- the amount of spreading is proportional to the wavelength,  $\lambda$
- the amount of spreading is proportional to the inverse of the gap width,  $\frac{1}{w}$ .

The dark gap between the bright bands is worthy of closer examination. According to Huygens's wave model, each point on a wave front produces circular waves that overlap to produce the next wavefront. When a straight wavefront meets a small gap, each point in the gap produces circular waves, which means the next wavefront spreads out to be wider than the gap.

Now let us investigate what happens off to the side. Consider the rays travelling at an angle  $\theta$  such that:

$$\sin \theta = \frac{\lambda}{w}$$

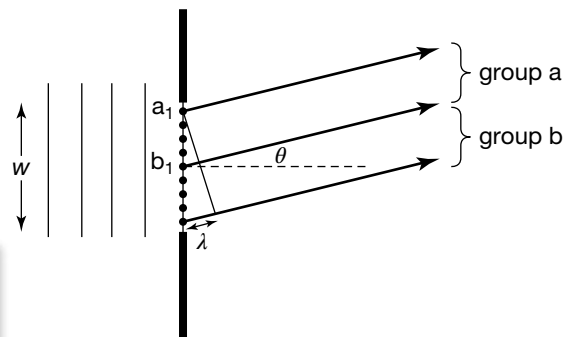

Point sources in a diffraction gap

Divide the point sources in the gap into two groups, a and b. Pairing up the top point source of group a,  $a_1$ , with the top point source of group b,  $b_1$ , shows there is a path difference of  $\frac{\lambda}{2}$ . Therefore, waves from  $a_1$  and  $b_1$  will cancel in the direction of  $\theta$ . Similarly, waves from  $a_2$  and  $b_2$  will cancel, and so on. So for the angle  $\theta$ , waves from half of the point sources in the gap will cancel with waves from the other half. This means there will be a dark band, or as it is called a first minimum, at an angle that satisfies the relationship  $\sin \theta = \frac{\lambda}{w}$ .

This relationship provides an explanation for the observations of the diffraction of light:

- A longer wavelength  $\Rightarrow$  the angle of the first minimum is greater  $\Rightarrow$  the pattern is wider.
- A larger gap width  $\Rightarrow$  the angle of the first minimum is smaller  $\Rightarrow$  the pattern is narrower.

## Diffraction and optical instruments

Diffraction limits the usefulness of any optical instrument, whether it be your eye, a microscope or a telescope. It even affects radio telescopes.

The pupil of your eye is the circle through which light enters the eye. The objective lens of a microscope or a telescope determines how much light the instrument captures. These all have a width, so a diffraction effect is unavoidable. Diffraction limits the instrument's capacity to distinguish two objects that are very close to each other.

In the following images, light from two close sources passes an optical device and produces image (a), showing two distinct spots. When the two sources are moved closer together, image (b) is produced, and the spots begin to merge. Moving the two sources even closer together produces image (c); the two spots are now one broad spot. At the separation that produces image (b), the diffraction patterns produced by the optical device begin to overlap so that the central maximum of one pattern sits on the minimum of the other. This separation is the limit of the device to resolve the detail in an image; it is called the diffraction limit or resolution of the device.

The diffraction limit of a device depends on the ratio  $\frac{\lambda}{w}$ . Thus, a shorter wavelength gives a better resolution, as does a larger aperture for the optical device.

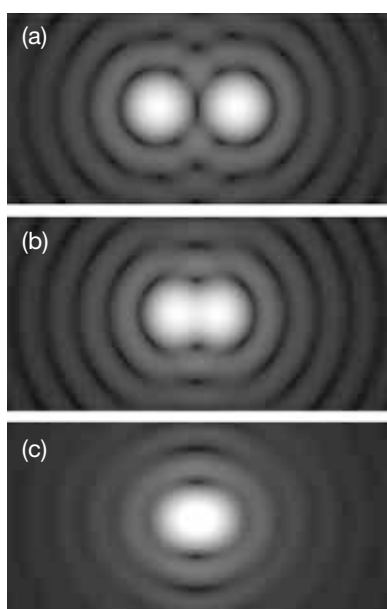

Images produced by two point light sources as they get closer, from (a) to (c).

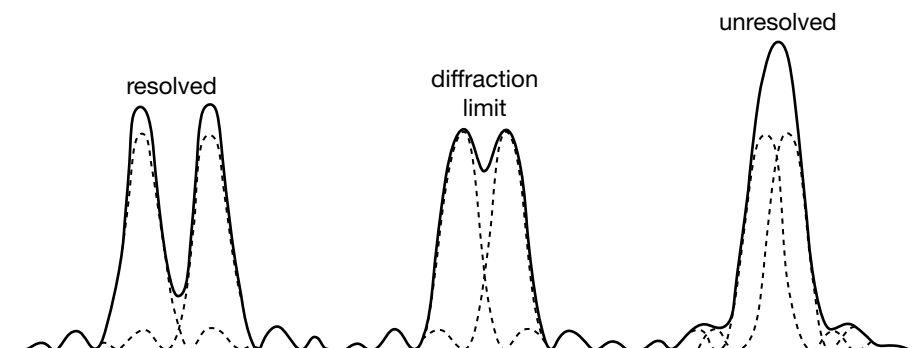

The diffraction patterns of two point sources overlap as the sources move closer together.

## Linking diffraction and interference

When light from a point source illuminates a double slit, each slit produces its own diffraction pattern with a wide central maximum and smaller side maxima. If the two slits are close together, these two patterns overlap, and the light coming from each slit interferes with the light coming from the other slit. This causes light and dark bands where the two central maxima overlap and also where the side maxima overlap.

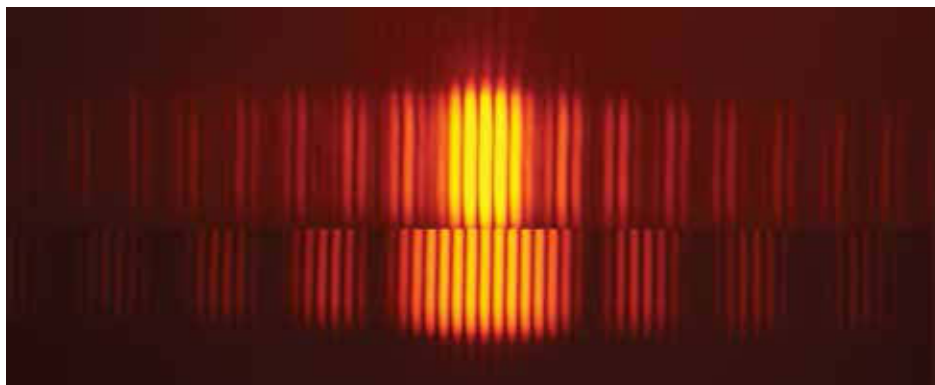

Interference pattern from two slits that are not extremely narrow. The slits in the bottom diagram are narrower than those for the top diagram because the central maximum is wider.

Normally, to emphasize the key features of interference, the pattern is prepared with slits that are so narrow that the central maximum fills the screen and the side maxima are not observed.

### study on

Unit 4

AOS 1

Topic 2

Concept 1

#### Electromagnetic waves

Concept summary and practice questions

## Light as an electromagnetic wave

Young had shown that the behaviour of light passing through narrow slits could be explained using ideas of waves. He had even measured the wavelengths of light in the visible spectrum, but he did not know what sort of wave light might be. James Clerk Maxwell (1831–1879) provided the answer in 1864. He began with the ideas of electric and magnetic interactions that are discussed in chapters 5, 6 and 7. From these ideas he developed a theory predicting that an oscillating electric charge would produce an oscillating electric field, together with a magnetic field oscillating at right angles to the electric field. These inseparable fields would travel together through a vacuum like a wave and the speed of the wave would be the same, whether the oscillations were rapid (high frequency and a short wavelength) or very slow (low frequency and a long wavelength). Maxwell predicted their speed, using known electric and magnetic properties of a vacuum, to be  $3 \times 10^8 \text{ m s}^{-1}$ . This is the speed of light! Maxwell had produced a theory that explained how light was produced and travelled through space as

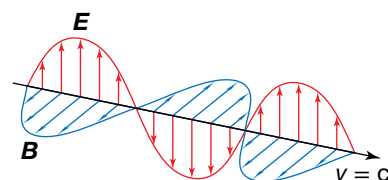

An electromagnetic wave. The electric and magnetic fields are uniform in each plane, but vary along the direction of the motion of the wave.

electromagnetic waves. This applied not only to visible light, but also to other radiation that we cannot see, such as infra-red and ultraviolet radiation. Furthermore, his electromagnetic model of light indicated that light could be described as transverse wave.

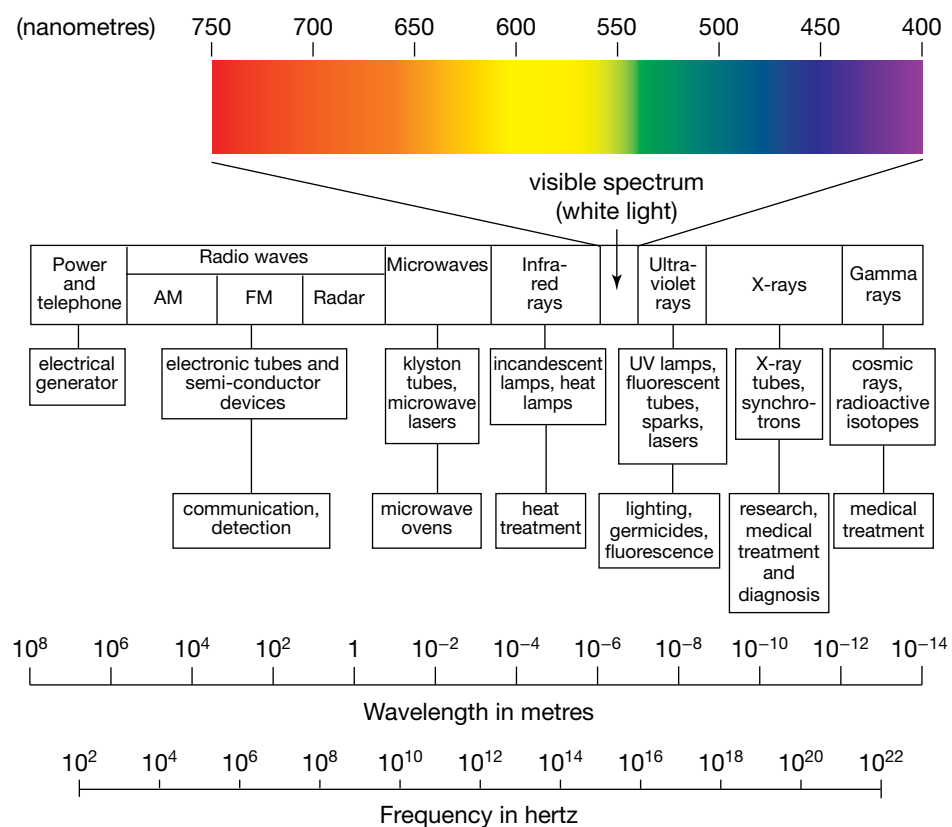

Forms of radiation and their place in the electromagnetic spectrum. The visible portion of the spectrum is shown enlarged in the upper part of the diagram.

**TABLE 10.3** Frequency and wavelength of colours

	Red	Orange	Yellow	Green	Blue	Violet
Frequency ( $\times 10^{12}$ hertz)	430	480	520	570	650	730
Wavelength (nanometres)	700	625	580	525	460	410

**Sample problem 10.6**

When light with a frequency of  $5.6 \times 10^{14}$  Hz travels through a vacuum, what is its:

- (a) period
- (b) wavelength (in nanometres)?

The speed of light in a vacuum is  $3.0 \times 10^8$  m s<sup>-1</sup>.

**Solution:** (a)  $T = \frac{1}{f}$   
 $= \frac{1}{5.6 \times 10^{14}}$   
 $= 1.8 \times 10^{-15}$  s

The period of the light is  $1.8 \times 10^{-15}$  seconds.



$$\begin{aligned}
 \text{(b) } \lambda &= \frac{c}{f} \\
 &= \frac{3.0 \times 10^8}{5.6 \times 10^{14}} \\
 &= 5.4 \times 10^{-7} \text{ m}
 \end{aligned}$$

The wavelength of visible light is usually expressed in nanometres (nm).

$$1 \text{ nm} = 1 \times 10^{-9} \text{ m}$$

$$\lambda = 5.4 \times 10^2 \text{ nm}$$

The wavelength of the light is 540 nanometres.

### Revision question 10.6

Find the frequency and period of light with a wavelength of 450 nm.

The frequency of a light ray is determined by the source (that is, what produces the light). The speed of the light is determined by the material the light is passing through. (The refractive index is a measure of how much the light is slowed down by the material.) This means that, when light passes from air into water, the frequency stays the same, the speed decreases and the wavelength must also decrease.

When you are under water and you look around, the objects you see still have the same colour. This means that your eye is responding to the frequency of the light ray and not to its wavelength. The world would be a strange place if the eye's response was the other way round.

Maxwell's theoretical wave model for light was able to show that the energy associated with electromagnetic waves was related to the size or amplitude of the wave. The more intense the wave, the greater the amplitude, and hence the energy it contained. He was also able to show that an electromagnetic wave had momentum and was thus capable in principle of exerting forces on other objects. According to Maxwell's model the amount of momentum contained in an electromagnetic wave  $p$  is related to the energy contained in the wave,  $E$ , by the simple equation  $p = \frac{E}{c}$  or  $E = pc$ .

In Unit 1 you studied the electromagnetic radiation given off by hot objects, in particular, Wien's Law and the Stefan-Boltzmann relationship. At that stage there was no explanation for those relationships or the shape of graph of intensity against wavelength. At about the same time as Maxwell was developing his theory of electromagnetism, Max Planck (1858–1947) was seeking an explanation for the shape of the intensity-wavelength graph. He could make his mathematical models fit the available data only if he conceded that the energy associated with the electromagnetic radiation emitted was directly proportional to the frequency of radiation and that the energy came in bundles that he called quanta. Thus  $E = hf$ , where  $h$  is a constant and has come to be known as 'Planck's constant'. Planck's constant is equal to  $6.63 \times 10^{-34} \text{ J s}$ .

What all of this meant was not clear — Maxwell's wave model for light worked extremely well and yet understanding incandescent objects required a model that concentrated energy into localised packets called quanta that were more like particles. It would be for Albert Einstein to interpret this apparent quandary with other experimental data over a decade later. For this discovery he would win the Nobel Prize for Physics in 1921.

### Sample problem 10.7

- (a) Blue light has a frequency of  $6.7 \times 10^{14}$  Hz.  
(i) Calculate the energy associated with a bundle of blue light.  
(ii) Find the momentum associated with a quantum of blue light.  
(b) Find the momentum of a quantum of red light of wavelength 650 nm.

**Solution:** (a) (i) The energy of the blue light  $E$  is given by:

$$\begin{aligned} E &= hf \\ &= 6.63 \times 10^{-34} \times 6.7 \times 10^{14} \\ &= 4.4 \times 10^{-19} \text{ J.} \end{aligned}$$

(ii) The momentum  $p$  is given by:

$$\begin{aligned} p &= \frac{E}{c} \\ &= \frac{4.4 \times 10^{-19}}{3 \times 10^8} \\ &= 1.5 \times 10^{-27} \text{ N s.} \end{aligned}$$

- (b) From the wavelength we can find the frequency. From the frequency we can find the energy. From the energy we can find the momentum. We can combine these three steps into one.

$$f = \frac{c}{\lambda} \Rightarrow E = hf \Rightarrow E = \frac{hc}{\lambda}$$

$$\text{Now } p = \frac{E}{c} \Rightarrow p = \frac{hc}{\lambda c} \Rightarrow p = \frac{h}{\lambda}.$$

$$\begin{aligned} p &= \frac{h}{\lambda} \\ &= \frac{6.63 \times 10^{-34}}{6.5 \times 10^{-7}} \\ &= 1.00 \times 10^{-27} \text{ N s} \end{aligned}$$

### Revision question 10.7

A quantum of light has a momentum of  $9.8 \times 10^{-28}$  N s. Calculate the frequency of the light.

## Polarisation

The transverse wave model of electromagnetic radiation developed by James Maxwell in 1873 proposes that light and other electromagnetic waves travel in many planes. Two hundred years earlier, the wave model of Christiaan Huygens proposed that light travelled as longitudinal waves — like sound.

The following figure shows what happens when a transverse wave in a vertical plane passes through a vertical slit. A transverse wave in a horizontal plane is unable to pass through a vertical slit. If transverse waves in many planes were to approach the slit, only the waves in the vertical plane would pass through. This blocking of waves except for a single plane is called **polarisation**. The next figure shows how a longitudinal wave can pass through both slits. Longitudinal waves cannot be polarised.

### eBook plus

**Weblink**  
Polarisation

**Polarisation** is the blocking of transverse waves except for those travelling in a single plane.

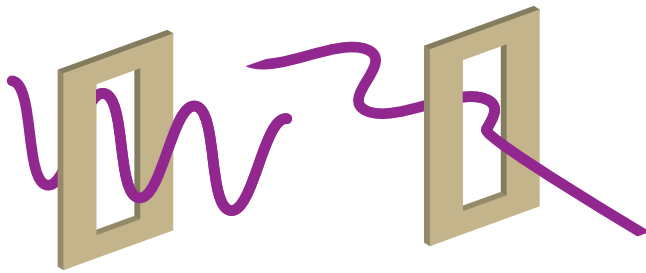

Waves in a vertical plane pass through the slit. The waves in a horizontal plane cannot pass through.

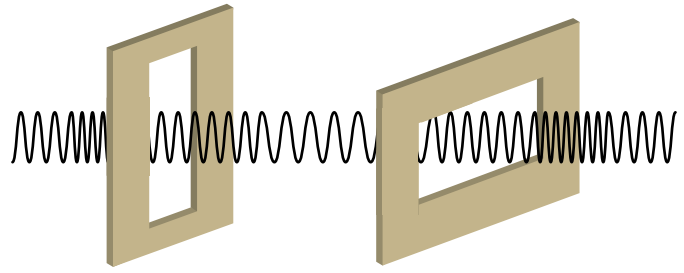

Longitudinal waves can pass through both vertical and horizontal slits.

**study on**

Unit 4

**Polarisation**

AOS 1

Concept summary and practice questions

Topic 2

Concept 2

Observations of the polarisation of light show that light is a transverse wave rather than a longitudinal wave, as longitudinal waves cannot be polarised. The polarisation of light is observed when it passes through some materials. These materials, which allow light waves in one plane to pass while blocking light in all other planes, are called polarising filters.

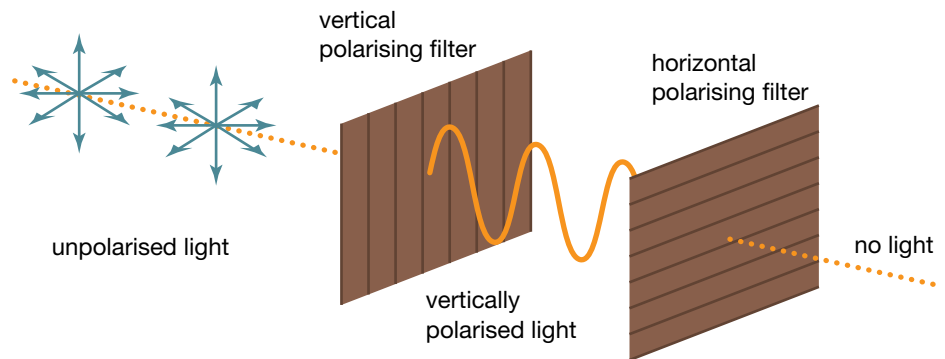

Light passed through crossed polarisers — polarising filters at right angles to each other

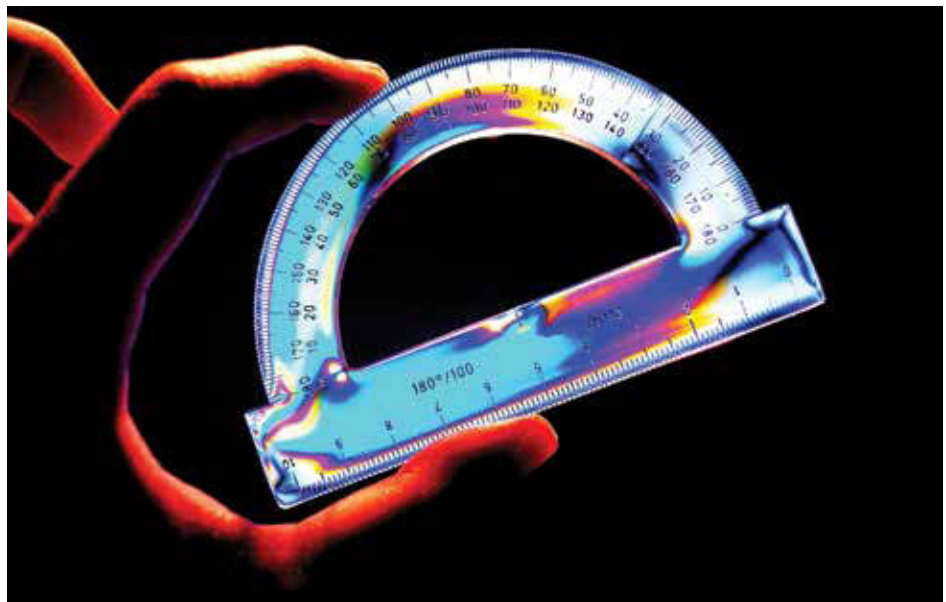

A protractor seen through crossed polarisers

**Weblink**

Polarised light applet

**AS A MATTER OF FACT**

- Sunglasses with polarising lenses cut out the glare from reflective surfaces such as water and roads. Reflected light is polarised in the horizontal direction, so putting the plane of the polarising filter in the vertical cuts out glare.
- Bees can see the polarisation pattern of the sky and use it to locate sources of pollen. In fact, many insects, fish, amphibians, arthropods and octopi use polarisation of light.
- Stresses in transparent objects can be detected using polarisation. The object to be observed is placed between crossed polarisers. Light passes through the object towards a camera. Normally, no light would pass through the crossed polarisers. However, regions under stress can rotate the plane of polarisation. This allows some light to get through, creating a photographic image that reveals the stresses.

# Chapter review



## Summary

- Light bends as it travels from one medium to another. A measure of a medium's capacity to bend light is given by its refractive index.
- If light travels into a medium of a higher refractive index, the light is bent towards the normal. If light travels into a medium of a lower refractive index, the light is bent away from the normal. This change in direction is summarised in Snell's Law. Snell's Law can be expressed as  $n_1 \sin \theta_1 = n_2 \sin \theta_2$ .
- When light travels into a medium of a lower refractive index, there will be an angle of incidence for which the angle of refraction is  $90^\circ$ . This angle of incidence is called the *critical angle*. For angles of incidence greater than the critical angle, all the light is reflected back into the medium. This phenomenon is called *total internal reflection*.
- Light consists of a mixture of colours, and when these colours enter a material they refract at different angles. This means that a material has a different refractive index for each colour. The resulting separation of light into different colours is called dispersion.
- Light is a form of electromagnetic radiation that can be modelled as transverse waves with colours differing in frequency and wavelength.
- The equation  $c = f\lambda$  describes the speed of a wave in terms of its frequency,  $f$ , and wavelength,  $\lambda$ .
- The speed of light in a uniform medium is a constant and is given by the equation  $v = \frac{c}{n}$ , where  $c$  is the speed of light in a vacuum and  $n$  is the refractive index of the medium.
- The behaviour of light, particularly refraction, diffraction and two-slit interference, is strong evidence for the wavelike properties of light.
- The amount of diffraction is determined by the ratio  $\frac{\lambda}{w}$ .
- Interference patterns resulting from light passing through two narrow slits can be explained using the wave principles of constructive and destructive interference of waves that are in phase and out of phase respectively. This interference results from a path difference.
- In an interference pattern, a region of intense light or maxima results from a path difference of  $0, \pm\lambda, \pm2\lambda, \pm3\lambda, \dots$
- In an interference pattern, a region of no light or minima results from a path difference of  $\pm\frac{1}{2}\lambda, \pm\frac{3}{2}\lambda, \pm\frac{5}{2}\lambda, \dots$

- The amount of diffraction is related to the wavelength of light and the size of the opening or obstacle. The greater the wavelength, the more evident the diffraction effects. The smaller the size of an opening or obstacle, the more evident the diffraction effects.
- Transverse waves, including light, can be polarised. Polarisation is the blocking of transverse waves except for those in a single plane.

## Questions

The data presented in table 10.1 may be used where relevant in the questions on the following pages.

### Refraction

- What is the angle of refraction in water ( $n = 1.33$ ) for an angle of incidence of  $40^\circ$ ? If the angle of incidence is increased by  $10^\circ$ , by how much does the angle of refraction increase?
- A ray of light enters a plastic block at an angle of incidence of  $55^\circ$  with an angle of refraction of  $33^\circ$ . What is the refractive index of the plastic?
- A ray of light passes through a rectangular glass block with a refractive index of 1.55. The angle of incidence as the ray enters the block is  $65^\circ$ . Calculate the angle of refraction at the first face of the block, then calculate the angle of refraction as the ray emerges on the other side of the block. Comment on your answers.
- Immiscible liquids are liquids that do not mix. Immiscible liquids will settle on top of each other, in the order of their density, with the densest liquid at the bottom. Some immiscible liquids are also transparent.
  - Calculate the angles of refraction as a ray passes down through immiscible layers as shown in the figure below.

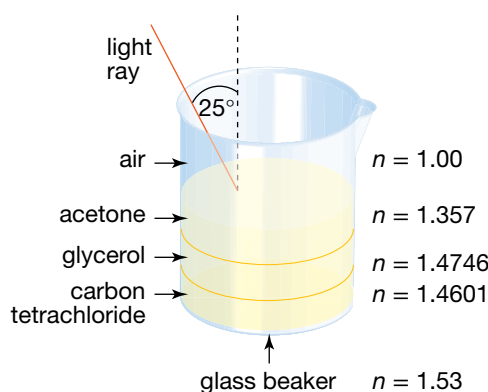

(b) If a plane mirror was placed at the bottom of the beaker, calculate the angles of refraction as the ray reflects back to the surface. Comment on your answers.

5. A ray travelling through water ( $n = 1.33$ ) approaches the surface at an angle of incidence of  $55^\circ$ . What will happen to the ray? Support your answer with calculations.
6. (a) To appear invisible you need to become transparent. What must your refractive index be if your movement is not to be detected?  
(b) The retina of your eye is a light-absorbing screen. What does that imply about your own vision if you are to remain invisible? (*Hint: If you are invisible all light passes through you.*)
7. Calculate the angle of deviation at a glass-air interface for an angle of incidence of  $65^\circ$  and refractive index of glass of 1.55.
8. Calculate the sideways deflection as a ray of light goes through a parallel-sided plastic block ( $n = 1.4$ ) with sides 5.0 cm apart, as in the figure below.

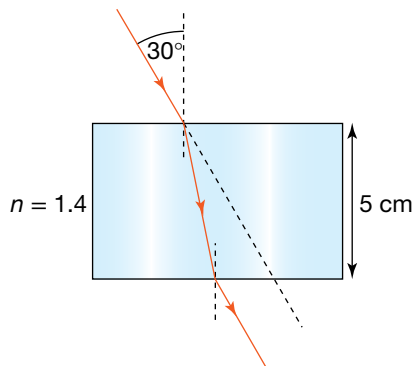

9. Calculate the angle of deviation as the light ray goes through the triangular prism shown in the figure below.

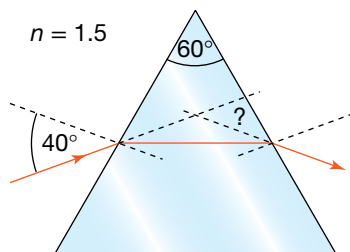

10. A ray of light enters a glass sphere ( $n = 1.5$ ), as in the figure below. What happens to the ray?

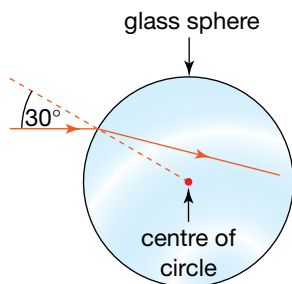

## Total internal reflection

11. Calculate the critical angle for light travelling through a diamond ( $n = 2.5$ ) towards the surface.
12. (a) Calculate the refractive index of the glass prism shown in the figure below so that the light ray meets the faces at the critical angle. Is this value of the refractive index the minimum or maximum value for such a reflection?  
(b) Draw two parallel rays entering the block. How do they emerge?

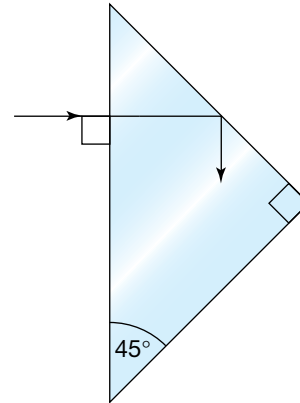

13. Calculate the refractive index of the plastic coating on an optical fibre if the critical angle for glass to plastic is  $82.0^\circ$  and the refractive index of glass is 1.500.
14. Describe what a diver would see when looking up at a still water surface.
15. A right-angled glass prism ( $n = 1.55$ ) is placed under water ( $n = 1.33$ ), as shown in the figure below.

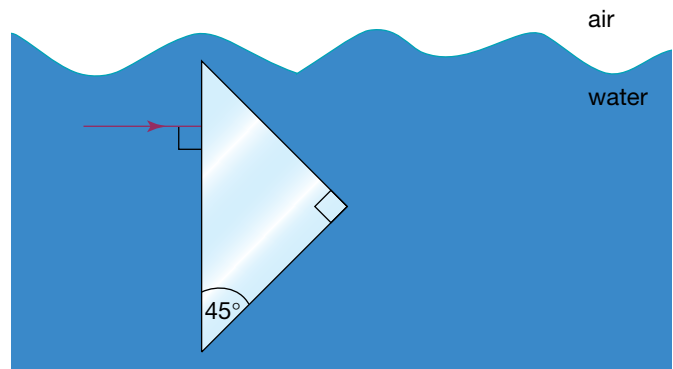

A ray of light enters the longest side along the normal. What happens to the ray of light?

16. A fish looking up at the surface of the water sees a circle, inside which it sees the 'air world'. Outside the circle it sees the reflection of the 'water world'. If the fish is 40 cm below the surface, calculate the radius of the circle ( $n_{\text{water}} = 1.33$ ).
17. Light enters an optical fibre  $1.0 \mu\text{m}$  in diameter, as shown in the following figure. Some light goes straight down the centre. Another ray is angled, leaving the central line and meeting the outside

edge at slightly more than the critical angle of  $82^\circ$  then reflects back to the central line.

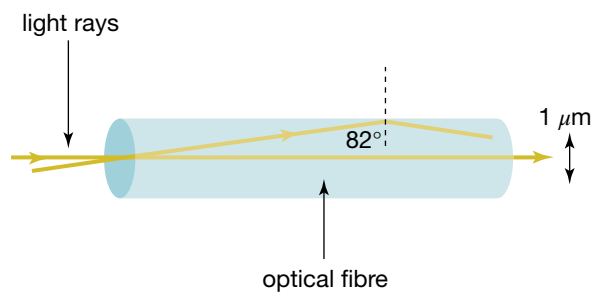

- How much further did this ray travel?
- Calculate the speed of light in the glass and determine the time delay between the two rays after one internal reflection. Do you think this could be a problem in an optical fibre? If so, when? How could the problem be overcome?

### Dispersion

- Give the meaning of the following terms: refraction, reflection, dispersion, spectrum, refractive index, chromatic aberration.
- (a) White light enters a crown glass rectangular prism. Sketch the path of red and deep blue light through the glass and back into air. How does the direction of the emerging coloured rays compare with that of the incoming white ray?  
(b) Suggest why a glass triangle is used to observe the visible spectrum, rather than a glass rectangle.
- Which travels faster through crown glass — red light or violet light? What is the speed difference?
- Green and violet light enter a triangular prism. Which is bent more?
- Draw red and violet light rays going through an inverted prism.
- Red, green and violet light emerge from a triangular prism and enter an inverted prism. Carefully trace the three paths through these prisms. What do you think you would see at the other end?
- Will a convex lens have a longer focal length for red or violet light? Explain, referring to how light bends at the front and back surfaces of the lens.
- (a) In what direction would you need to look to see a rainbow (i) early in the morning (ii) at midday?  
(b) In what direction would a person in the Northern Hemisphere look to see a rainbow (i) early in the morning (ii) at midday?
- You look out of an aeroplane window and see a rainbow. Where would the Sun be? What would be the shape of the rainbow?

### The wave model

- Calculate the period of orange light, which has a frequency of  $4.8 \times 10^{14}$  Hz.
- When blue light of frequency  $6.5 \times 10^{14}$  Hz travelling through the air meets a glass prism, its speed decreases from  $3.0 \times 10^8$  m s<sup>-1</sup> to  $2.0 \times 10^8$  m s<sup>-1</sup>. Calculate the wavelength of the blue light in: (a) the air (b) the glass.
- A ray of white light passes from air into crown glass at an angle of incidence of  $30^\circ$ . Calculate the angles of refraction for red light ( $n = 1.4742$ ) and blue light ( $n = 1.4810$ ). Calculate the angle between the red and blue light rays.
- The refractive indices of diamond for red and blue light are 2.40 and 2.44, respectively. Calculate the critical angles for both red and blue light in diamond.
- Refer back to question 19(a). Both emerging coloured rays have been shifted sideways compared with the incoming ray. (a) Calculate how much each colour has been shifted if the angle of incidence for the incoming ray is  $45^\circ$  and the thickness of the block is 5.0 cm.  
(b) Which colour is shifted more and by how much more?  
(c) Does this shift depend on the angle of incidence? Try some other values for the angle of incidence.
- The shape of a rainbow is circular. When would you see: (a) a small arc only (b) a semicircle?
- Is a rainbow produced by total internal reflection or just reflection? It has been suggested that the light is totally internally reflected at the back surface of the raindrop, rather than undergoing partial reflection and partial transmission.
- A secondary rainbow is formed when the ray of light from the sun enters at the bottom of the raindrop, reflects twice then emerges from the top. (a) Draw a large circle to represent the raindrop and draw the paths of the red and violet rays through the raindrop.  
(b) What do you expect to be the order of the colours in the secondary rainbow? How else will the secondary rainbow differ?
- Explain, with the aid of a diagram, why polarisation would not be possible if light behaved like a longitudinal wave.
- A ray of white light enters a rectangular glass block at an angle of  $45^\circ$ . The block is 10 cm deep and has refractive indices for red and violet light of  $n = 1.514$  and  $n = 1.532$ , respectively. The refractive index is a measure of how much the light is slowed down (speed of light =  $300\,000$  km s<sup>-1</sup>). (a) Calculate the speeds of the red and violet light in the glass block.

- (b) Calculate the angles of refraction for the red and violet light and the length of the path of each colour through the glass block.
- (c) Which colour emerges from the glass first?
- (d) Draw the paths of the red and violet light through the glass block. How do the two paths compare after they emerge from the block?
- (e) Which ray ends up ahead?

37. Newton shone a narrow beam of light from a small hole in a curtain onto a glass triangular prism. The visible spectrum of colours was produced in the emerging beam. He then placed a screen with a small hole in it in the path of the spectrum to allow only the red light through the hole onto another glass prism (see the figure below). The red light emerged from the second prism unchanged in any way. Why do you think Newton carried out this second stage of the experiment?

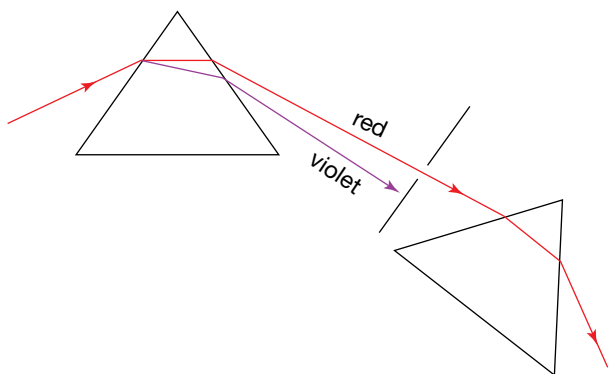

## Diffraction

38. Consider the diffraction pattern produced when light passes through a narrow opening.
- (a) Explain how the first minima in the pattern occur in terms of the interference of waves.
  - (b) Sketch the diffraction pattern produced by blue light and red light passing through the same narrow opening on the same axes.
  - (c) Repeat (b) but this time for light passing through an opening that is narrower.
39. White light passed through a narrow slit and projected onto a distant screen shows bright and dark bands with coloured fringes.
- (a) Explain how the coloured fringes arise.
  - (b) Red fringes are observed at the further extent from the central white maximum. Why?
40. To the eye, the red light from a neon discharge tube appears very similar to the glow of a red-hot coal in a fire. A spectroscope shows that light emitted by the hot coal is a continuous spectrum, with the greatest intensity in the red part of the spectrum. However, neon does not emit light across the whole spectrum. Instead, many sharp

lines of pure colour are seen in the red part of the spectrum. Explain why the neon spectrum is so different.

41. List several different path differences that would produce constructive interference for infra-red radiation with a wavelength of  $1.06 \mu\text{m}$ . Now list several path differences that would produce destructive interference.
42. A student shines a helium–neon laser, which produces light with a wavelength of  $633 \text{ nm}$ , through two slits and produces a regular pattern of light and dark patches on a screen as shown below. The centre of the pattern is the band marked A. Using a wave model for light we can describe light as having *crests* and *troughs*.

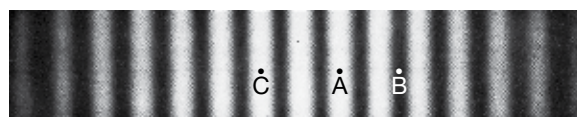

- (a) Use these terms to explain:
    - (i) the bright band labelled A in the diagram above
    - (ii) the dark band labelled B.
  - (b) What is the difference in the distance light has travelled from the two slits to:
    - (i) the bright band labelled A
    - (ii) the dark band labelled B
    - (iii) the bright band labelled C?
  - (c) Using the same experimental setup, but replacing the laser with a green argon ion laser emitting  $515 \text{ nm}$  light, what changes would occur to the interference pattern?
  - (d) The helium–neon laser is set up again. The distance between the two slits is now increased. What changes to the interference pattern shown in the diagram above would occur?
  - (e) The screen on which the interference pattern is projected is moved further away from the slits. What changes to the interference pattern shown in the diagram would occur?
43. When we draw diagrams to illustrate the interference between light emerging through two narrow slits we usually draw straight, parallel wavefronts approaching the slits, but circular wavefronts leaving the slits. When is it appropriate, and when would it not be appropriate, to draw circular wavefronts leaving the slits?
44. If you take a loop of wire, dip it in a soap solution and look at the soap film draining you will notice that there are coloured horizontal stripes across the film as seen in the photograph below. These stripes move down the film as it drains to the bottom of the loop. If the coloured stripes are caused by interference



between light reflected from the front and back of the film, explain why the stripes move.



45. Red light (650 nm) and blue light (360 nm) is shone simultaneously through a diffraction grating where the slit width is  $0.70 \mu\text{m}$ . The light falls onto a screen positioned 3.0 m from the grating. Explain why the diffraction pattern is coloured magenta in the middle of the pattern but gradually changes colour to red.
46. Think about light at the two ends of the visible spectrum, violet and red.
- Which of these two colours will produce a broader pattern of light and dark bands when passed through a narrow slit, about  $0.01 \text{ mm}$  wide?
  - Use your answer to (a), and your knowledge of the mixing of colours to explain why it is, when white light is shone through the same slit, the edges of the white central band appear to be yellow.
47. Light of wavelength 430 nm falls on a double slit of separation  $0.500 \text{ mm}$ . What is the distance between the central bright band and the third bright band in the pattern on a screen  $1.00 \text{ m}$  from the double slit.

48. A double slit is illuminated by light of two wavelengths, 600 nm and the other unknown. The two interference patterns overlap with the third dark band of the 600 nm pattern coinciding with the fourth bright band from the central band of the pattern for the light on unknown wavelength. What is the value of the unknown wavelength?
49. When light enters a glass block, it is refracted, but some light is also reflected. For a particular angle of incidence, the angle between the reflected ray and the refracted ray is  $90^\circ$ . At this angle of incidence, called the Brewster angle,  $\theta_B$ , the reflected ray is polarised. Show that  $\tan \theta_B = n_g$ , where  $n_g$  is the refractive index of glass.

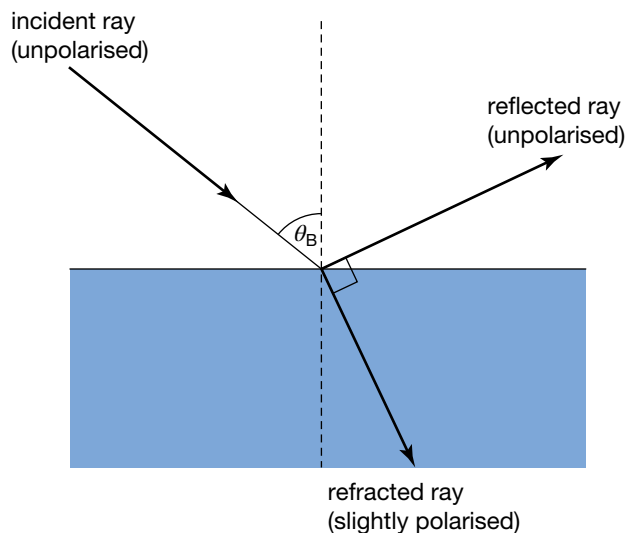

50. Glare at the beach is partly caused by polarised light reflected from the sand and the water. The light is polarised in the horizontal plane of the two surfaces. What should be the orientation of polaroid sunglasses to block out the glare?

## The photoelectric effect

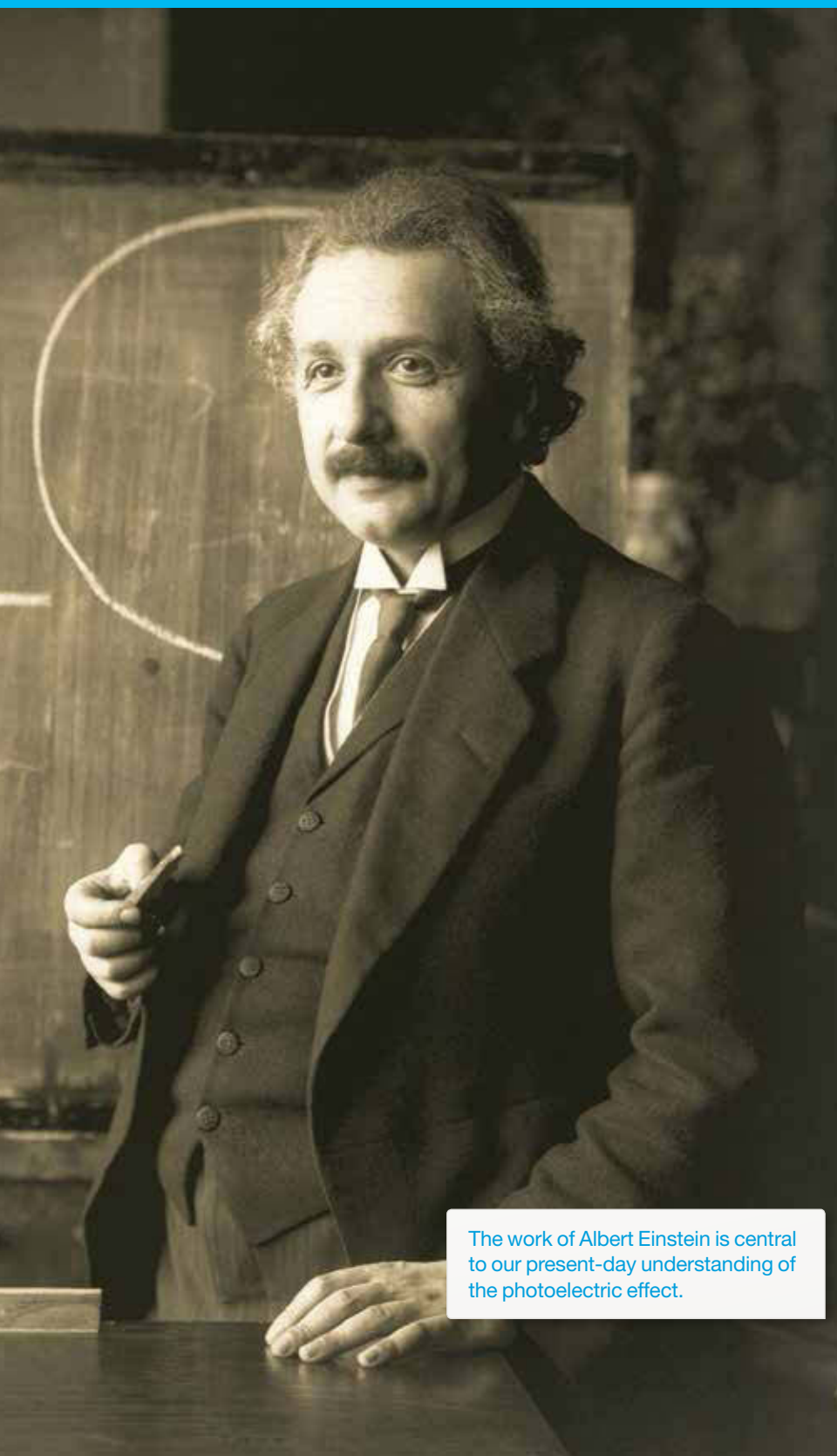

The work of Albert Einstein is central to our present-day understanding of the photoelectric effect.

## REMEMBER

Before beginning this chapter, you should be able to:

- use the equation  $c = f\lambda$  for light
- equate the work done,  $W = Vq$ , with the change in kinetic energy,  $\Delta E_k$
- apply simple wave and particle models to explain the behaviour of light.

## KEY IDEAS

After completing this chapter, you should be able to:

- interpret the photoelectric effect as evidence for the particle-like nature of light
- describe why the wave model for light cannot account for the experimental results produced by the photoelectric effect
- calculate the kinetic energy,  $E_k$ , of a charged particle,  $q$ , having passed through a voltage,  $V$ , as a measure of the work done,  $W$ :  $W = Vq = \Delta E_k$
- calculate the energy of a photon of light using the equation  $E = hf$
- explain how the intensity of incident radiation affects the emission of photoelectrons from an irradiated electrode
- use the Einstein interpretation of the photoelectric effect and equation  $E_{k_{\max}} = hf - W$
- calculate the momentum of a photon of light using the equation  $p = \frac{h}{\lambda}$
- use information sources to assess risk in the use of light sources, lasers and related equipment.

## Physics before the observation of the photoelectric effect

By the latter half of the nineteenth century, the ability of Newtonian mechanics to predict and explain much of the material world was unquestioned. At the same time, discoveries in chemistry showed that the world consisted of many elements, each made up of identical atoms, and compounds made up of combinations of atoms in fixed proportion. Most scientists believed that all matter was made up of particles, and that the universe was governed by deterministic mechanical laws. That is, they thought the universe was like a big machine. Newtonian mechanics allowed them to explain the working of the universe in terms of energy transformations, momentum transfer, and the conservation of energy and momentum due to the action of well understood forces.

The modelling of light was also progressing well, with many experiments indicating light was a wave of some type. James Clerk Maxwell developed a set of equations that were able to explain all the existing observations of light at the time based on the premise that light was an electromagnetic wave, making an assertion as to the nature of light itself. Light came to be modelled as a transverse wave consisting of perpendicular electric and magnetic fields.

Thomas Young had shown that the behaviour of light passing through narrow slits could be explained using ideas of waves. He had even measured the wavelengths of light in the visible spectrum, but he did not know what sort of wave light might be. James Clerk Maxwell provided the answer in 1864. He began with the ideas of electric and magnetic interactions that you will have explored in electric power. From these ideas he developed a theory predicting that an oscillating electric charge would produce an oscillating electric field, together with a magnetic field oscillating at right angles to the electric field. These inseparable fields would travel together through a vacuum. Maxwell predicted their speed, using known electric and magnetic properties of a vacuum, to be  $3 \times 10^8 \text{ m s}^{-1}$ . This is the speed of light! Maxwell had produced a theory that explained how light was produced and travelled through space as electromagnetic waves. This applied not only to visible light, but also to other radiation that we cannot see, such as infra-red and ultraviolet radiation.

Maxwell's theoretical wave model for light was able to show that the energy associated with electromagnetic waves was related to the size or amplitude of the wave. The more intense the wave the greater the amplitude and hence the energy it contained. He was also able to show that an electromagnetic wave had momentum and was thus capable in principle of exerting forces on other objects. According to Maxwell's model the amount of momentum contained in an electromagnetic wave  $p$  is related to the energy contained in the wave  $E$  by the simple equation  $p = \frac{E}{c}$  or  $E = pc$ .

At the same time, Max Planck was trying to understand how hot objects emit electromagnetic waves. That is, he was studying light emitted by incandescent objects such as the sun, light bulbs or a wood fire. He could make his mathematical models fit the available data only if he conceded that the energy associated with the electromagnetic radiation emitted was directly proportional to the frequency of radiation and, importantly, that the energy came in bundles that he called quanta. Thus  $E = hf$ , where  $h$  is a constant and has come to be known as 'Planck's constant'. Planck's constant is equal to  $6.63 \times 10^{-34} \text{ J s}$ .

What all of this meant was not clear — Maxwell's wave model for light worked extremely well and yet understanding incandescent objects required a model that concentrated energy into localised packets called quanta that were more like particles.

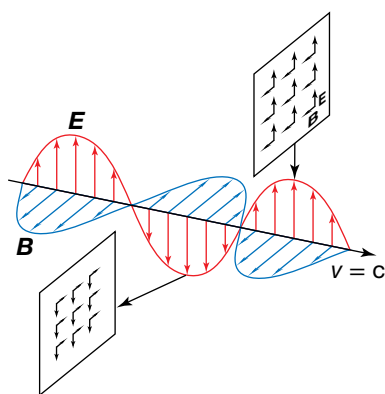

An electromagnetic wave. The electric and magnetic fields are uniform in each plane, but vary along the direction of the motion of the wave.

A pair of problems existed. One question was how matter could convert some of its kinetic and potential energy into light. Max Planck and other scientists were working on this problem as part of their efforts to understand black body radiation (that is, radiation emitted by incandescent objects). The other question was how light could transfer its energy to matter. This process became known as the photoelectric effect.

Planck's conclusion about a particle nature for light did not fit comfortably with the successful wave model of light proposed by Maxwell. It would be for Albert Einstein to interpret this apparent quandary with other experimental data over a decade later. In reward for his success, he won the Nobel Prize for Physics in 1921. Einstein's interpretation asserted that light is best thought of as a stream of particles, now called photons, with each photon carrying energy  $E_{\text{photon}} = hf$  and capable of transferring this energy to other particles such as electrons.

### Sample problem 11.1

- (a) Blue light has a frequency of  $6.7 \times 10^{14}$  Hz.  
 (i) Calculate the energy associated with a bundle of blue light.  
 (ii) Find the momentum associated with a quantum of blue light.  
 (b) Find the momentum of a quantum of red light of wavelength 650 nm.

**Solution:** (a) (i) The energy of the blue light  $E$  is given by:

$$\begin{aligned} E &= hf \\ &= 6.63 \times 10^{-34} \times 6.7 \times 10^{14} \\ &= 4.4 \times 10^{-19} \text{ J.} \end{aligned}$$

(ii) The momentum  $p$  is given by:

$$\begin{aligned} p &= \frac{E}{c} \\ &= \frac{4.4 \times 10^{-19}}{3 \times 10^8} \\ &= 1.5 \times 10^{-27} \text{ N s.} \end{aligned}$$

- (b) From the wavelength we can find the frequency. From the frequency we can find the energy. From the energy we can find the momentum. We can combine these three steps into one.

$$f = \frac{c}{\lambda} \Rightarrow E = hf \Rightarrow E = \frac{hc}{\lambda}$$

$$\text{Now } p = \frac{E}{c} \Rightarrow p = \frac{hc}{\lambda c} \Rightarrow p = \frac{h}{\lambda}$$

$$\begin{aligned} p &= \frac{h}{\lambda} \\ &= \frac{6.63 \times 10^{-34}}{6.5 \times 10^{-7}} \\ &= 1.00 \times 10^{-27} \text{ N s} \end{aligned}$$

### Revision question 11.1

A quantum of light has a momentum of  $9.8 \times 10^{-28}$  N s. Calculate the frequency of the light.

### Sample problem 11.2

- (a) What is the energy of each photon emitted by a source of green light having a wavelength of 515 nm?  
(b) How many photons per second are emitted by a light source emitting a power of 0.3 W as 515 nm light? (This power is similar to the power emitted by a 40 W fluorescent tube in the wavelength range  $515 \pm 0.5$  nm.)

**Solution:** (a) The photon energy can be found as follows:

$$\begin{aligned} E_{\text{photon}} &= \frac{hc}{\lambda} \\ &= \frac{6.63 \times 10^{-34} \text{ J s} \times 2.9979 \times 10^8 \text{ m s}^{-1}}{515 \times 10^{-9} \text{ m}} \\ &= 3.86 \times 10^{-19} \text{ J.} \end{aligned}$$

(b) The power emitted by the globe is:

$$\begin{aligned} \text{power} &= \frac{\text{energy emitted}}{\text{time interval}} \\ &= \frac{E}{\Delta t} \\ &= \frac{NE_{\text{photon}}}{\Delta t} \end{aligned}$$

where

$N$  is the number of photons emitted in the time interval  $\Delta t$ .

So

$$\begin{aligned} N &= \frac{\text{power} \times \Delta t}{E_{\text{photon}}} \\ &= \frac{0.3 \text{ W} \times 1 \text{ s}}{3.86 \times 10^{-19} \text{ J}} \\ &= 8 \times 10^{17} \text{ s}^{-1}. \end{aligned}$$

Since each photon carries a tiny amount of energy, huge numbers of photons are emitted from quite ordinary light sources in each second.

### Revision question 11.2

A radio station has a 1000 W transmitter and transmits electromagnetic radiation with a frequency 104.6 MHz. Calculate the number of photons emitted per second by the transmitter.

An **X-ray** is a form of electromagnetic radiation with a frequency above that of ultraviolet radiation.

A **cathode ray** is a stream of electrons emitted between a cathode (negative electrode) and an anode (positive electrode) in an evacuated tube.

**Fluorescent** describes the light emitted from materials as a result of exposure to external radiation.

## A mysterious radiation

A mysterious sort of radiation discovered in 1895 was given a mysterious-sounding name: **X-rays**. Wilhelm Röntgen was studying the behaviour of **cathode rays**. These rays travel from the negative electrode, the cathode, to the positive electrode, the anode, of an evacuated tube. These rays could travel the length of the evacuated tube but could not penetrate the end of the tube. Röntgen had completely covered the cathode ray tube with black cardboard and turned the lights off so he could check that the covering was opaque. He was amazed to see a weak glow, just like **fluorescent** paint,

about a metre away from the tube. By the light of a match he identified a fluorescent screen as the source of the only glow. The glow could not have occurred spontaneously because fluorescent materials glow as a result of the energy received when absorbing other radiation. Röntgen realised there must have been other radiation striking the fluorescent materials, but the room was completely dark, there were no ultraviolet sources and cathode rays could not cross a metre of air. He reasoned that there must be another form of radiation, produced by the tube, which *could* pass through the glass tube, through air and cross the room. After using a magnet to deflect the cathode rays it became clear that the new rays were produced at the point where the cathode rays struck the end of the tube. He called the radiation X-rays to indicate that they were a new form of radiation whose properties were not known.

Röntgen measured the penetration of these new rays through various substances, including his own hand, and noted their lack of deflection by magnetic and electric fields, and the absence of observable interference effects with usual optical diffraction gratings.

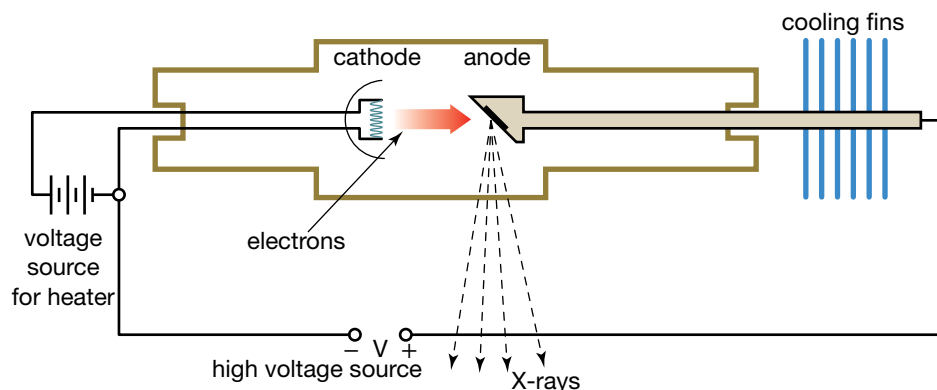

The Coolidge tube, invented in 1913, became the standard method of producing X-rays. Electrons from a heated cathode are accelerated by high voltage towards the anode whose face is angled at 45° to the electron beam. Their collision with atoms in the anode, a high melting point material, produces X-rays. The anode must be cooled.

The key question was: *Are the X-rays particles or waves?* Their straight paths through magnetic fields and electric fields eliminated the possibility of charged particles. Neutral particles or electromagnetic radiation were the remaining options, but the lack of observable interference seemed to rule out electromagnetic radiation.

X-radiation *is* electromagnetic radiation. Röntgen did not observe interference effects because of the diffraction grating he used. A grating is needed with 'slits' that are separated by a distance similar to the wavelength of X-rays, only  $10^{-10}$  m. Confirmation of the wave behaviour of X-rays was finally produced by experiments in which the 'slits' were provided by the regular layers of atoms of crystals. These layers are commonly separated by  $10^{-10}$  m, ideal to form a diffraction grating for X-rays. Max von Laue recommended, and his colleagues Friedrich and Knipping performed, the first demonstration of this wave behaviour when they directed a beam of X-rays through a thin crystal towards a photographic plate. After many hours of exposure the developed plate showed a delightfully symmetric pattern of bright spots on a dark background. These bright 'Laue spots' were evidence of constructive interference — X-rays *were* electromagnetic waves. This confirmation was not achieved until 1912.

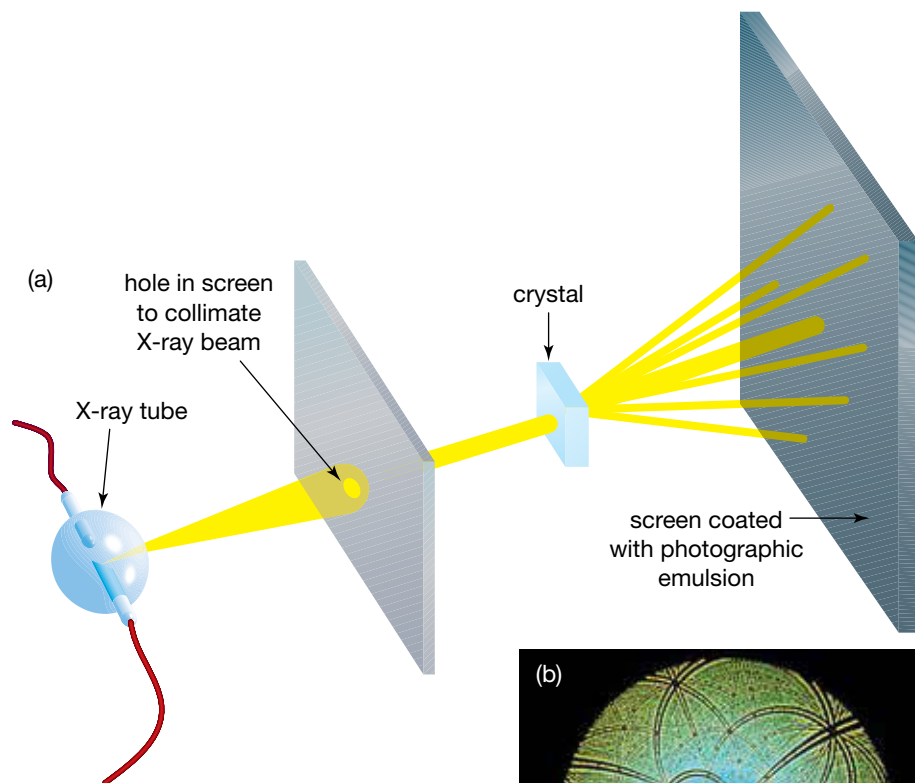

(a) Von Laue's experiment, and (b) spots of high X-ray intensity result from constructive interference. This wave diffraction pattern is from a crystal of the enzyme RuBisCO.

## Some preliminaries – measuring the energy of light and the energy of electrons

In order to appreciate the results of the photoelectric effect, it is necessary to be able to calculate both the energy associated with light and the energy associated with a moving particle such as an electron.

The energy associated with light,  $E$ , provided it is treated as a localised object as necessitated by Planck, can be equated to the product of the frequency and Planck's constant:  $E = hf$ . The speed of light is related to the frequency and wavelength:  $c = f\lambda$ , in accordance with a wave model for light. For completeness, since  $E = pc$ , the momentum associated with light,  $p$ , can be related to the wavelength  $\lambda$  by the equation  $p = \frac{h}{\lambda}$ . It needs to be mentioned at this stage that both a wave model for light and a particle model for light have been used simultaneously. This usage of two models simultaneously came to be known as the wave-particle duality, and for many years it remained an unresolved component in physics. With the development of quantum mechanics in the 1920s, a consistent mathematical model incorporating both aspects emerged.

Potential differences can be used to accelerate and decelerate charged particles. Let us now review how the kinetic energy of a charged particle can be related to the electrical potential difference through which it can be made to move. Understanding this relationship will make understanding

the photoelectric effect easier. It will be also useful to know how the kinetic energy of matter is related to its momentum, just as in the case for light.

The simplest way to accelerate electrons is with two parallel metal plates in an evacuated chamber (see the figure). The two plates are connected to a DC power supply (similar to a capacitor connected to a battery). An

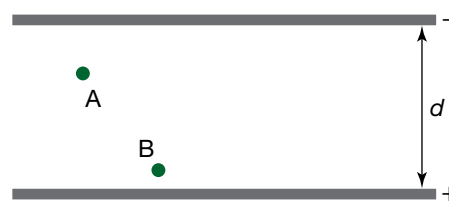

An electric field set up between two parallel plates connected to a battery

electron will experience an electric force anywhere in the region between the plates: it will be attracted by the positively charged plate and repelled by the negatively charged plate. Both of these forces act in the same direction.

The size of this force will also be the same throughout this region. At point A, the downward repulsive force on an electron from the negative plate will be greater than the downward attractive force of the positive plate. At point B, the downward attractive force will be greater. However, the combined effect of the two forces will be the same at each point.

This constant electric force on a charge placed between the plates can be compared to the constant gravitational force on a mass located above the ground. In gravitation, where the force acts on the mass of an object:

$$\text{gravitational force} = \text{gravitational field strength} \times \text{mass}$$

$$W = mg$$

With an electric force, the force acts on the electric charge of an object:

$$\text{electric force} = \text{electric field strength} \times \text{electric charge}$$

$$F = Eq$$

The electric field,  $E$ , can be expressed as electric force,  $F$ , divided by electric charge,  $q$ :

$$E = \frac{F}{q}$$

This equation is also applied to the magnitude of the electric field. That is,  $E = \frac{F}{q}$ . The unit of electric field is newtons per coulomb ( $\text{N C}^{-1}$ ), in the same way that the gravitational field can be measured in newtons per kilogram ( $\text{N kg}^{-1}$ ). However, the magnitude of the electric field can also be shown to be:

$$\text{electric field} = \frac{\text{voltage across the plates}}{\text{plate separation}}$$

$$E = \frac{V}{d}$$

These two relationships for the electric field ( $E = \frac{F}{q}$  and  $E = \frac{V}{d}$ ) give it two equivalent units: newtons per coulomb ( $\text{N C}^{-1}$ ) and volts per metre ( $\text{V m}^{-1}$ ). These two relationships can also be linked by considering energy. The gain in energy of the electron can be obtained by calculating the work done on the charge to move it from one plate to the other. It can also be obtained by recalling that the voltage across a battery equals the energy gained by one coulomb of charge. So:

$$\text{work} = \text{force} \times \text{distance} = \text{voltage} \times \text{electric charge}$$

$$\Rightarrow F \times d = V \times q$$



The work done by the potential difference,  $V$ , on a free electron is equal to the change in the kinetic energy of the electron,  $\Delta E_k$ . Since kinetic energy is given by the expression  $\frac{1}{2}mv^2$ , and by further making the assumption that the initial kinetic energy of an electron emitted by a filament is zero, we then get a useful non-relativistic equation:

$$E_k = Vq = \frac{1}{2}mv^2$$

We interpret this equation in the following way. For a given voltage,  $V$ , acting on an electron (mass  $m = 9.1 \times 10^{-31}$  kg and charge  $q = 1.6 \times 10^{-19}$  C), we are able to calculate both the speed of the electron and hence its momentum ( $p = mv$ ), as well as its energy,  $E_k$ .

Thus, an arrangement of negative and positive charged plates can be used to accelerate a charged particle in a straight line. This arrangement came to be known as an **electron gun**. By reversing the polarity of charge on the plates, electrons with energy can be decelerated. The voltage required to achieve this stopping of electrons with energy is known as a stopping voltage.

An **electron gun** is a device to provide free electrons for a linear accelerator. It usually consists of a hot wire filament with a current supplied by a low-voltage source.

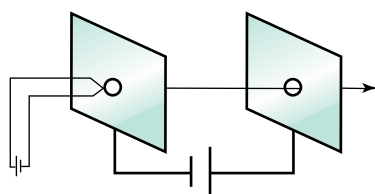

The electrons on the hot filament are attracted across to the positive plate and pass through the hole that is in line with the beam.

An **electron volt** is the quantity of energy acquired by an elementary charge ( $q_e = 1.6 \times 10^{-19}$  C) passing through a potential difference of 1 V. Thus,  $1.6 \times 10^{-19}$  J = 1 eV.

### study on

Unit 4

AOS 2

Topic 1

Concept 2

**Electron volt unit of energy**

Summary screen and practice questions

## Measuring the energy of photoelectrons

In the photoelectric effect, energy is transferred from light to electrons. Lenard was able to measure the maximum kinetic energy of photoelectrons by applying a retarding voltage to stop them. Recall that the work done on a charge,  $q$ , passing through a potential difference,  $V$ , is equal to  $qV$ . That is, an electron passing through a potential difference of 3.0 V would have  $1.6 \times 10^{-19}$  C  $\times$  3.0 J C<sup>-1</sup> =  $4.8 \times 10^{-19}$  J of work done on it. If the voltage is arranged so that the emitted electrons leave the positive terminal and are collected at a negative terminal, then electrons lose  $4.8 \times 10^{-19}$  J of energy. In the graph on page 12, the voltage,  $V$ , can be measured when the photocurrent drops to zero. This indicates that all the electrons which absorbed energy from light striking the electrode have been stopped. At this voltage — the so-called stopping voltage,  $V_0$  — the photoelectrons have had all their kinetic energy removed. Thus the kinetic energy that the photoelectrons left the surface with,  $E_k$ , is  $qV_0$ . In general, photoelectrons with a kinetic energy  $E_k$  will be stopped by a stopping voltage  $V_0$  such that  $E_k = qV_0$ .

The energy unit the joule is many orders of magnitude too large to be useful in describing energy changes in atoms. Instead we frequently use the **electron volt**, abbreviated to eV.

### Sample problem 11.3

An electron gun uses a 500 V potential difference to accelerate electrons evaporated from a tungsten filament. Model the evaporated electrons as having zero kinetic energy.

- How much work is done on an electron moved across a potential difference of 500 V?
- What type of energy is this work transformed into?
- Calculate the kinetic energy of the electrons in electron volt and joule.
- Using the equation for the kinetic energy,  $E_k$ , of a particle with mass  $m$ , determine the speed,  $v$ , of these electrons.
- Calculate the momentum of these electrons.

**Solution:**

- Use  $W = Vq = 500 \times 1.6 \times 10^{-19} = 8.0 \times 10^{-17}$  J or 500 eV.
- Potential energy available is transformed into the kinetic energy of the electron:  $W = Vq = \Delta E_k$ .

- (c) Assuming the initial kinetic energy of the electrons evaporated from a tungsten filament is 0, the kinetic energy of the electrons is equal to the work done:  $E_k = W = 8.0 \times 10^{-17} \text{ J}$  or 500 eV.
- (d)  $E_k = \frac{1}{2}mv^2 = 8.0 \times 10^{-17} \text{ J}$ , provided the electron speed is sufficiently small to ignore relativistic effects. Take the mass of an electron to be  $m = 9.1 \times 10^{-31} \text{ kg}$  and solve equation for  $v$ . Thus:

$$v = \sqrt{\frac{2E_k}{m}} = \sqrt{\frac{2 \times 8.0 \times 10^{-17}}{9.1 \times 10^{-31}}} = 1.33 \times 10^7 \text{ m s}^{-1}$$

This is substantially slower than the speed of light; therefore, we can ignore relativistic effects.

- (e)  $p = mv = 9.1 \times 10^{-31} \times 1.33 \times 10^7 = 1.2 \times 10^{-23} \text{ N s}$

### Revision question 11.3

An electron in a beam of electrons generated by an electron gun has energy  $1.26 \times 10^{-17} \text{ J}$ .

- (a) Calculate the energy of this electron in electron volts.  
 (b) State the potential difference required to stop electrons with this energy, that is to remove their kinetic energy and bring them to rest.  
 (c) Determine the speed of the electron, assuming that its kinetic energy is given by the equation  $E_k = \frac{1}{2}mv^2$ .  
 (d) Use your answer to (c) to calculate the momentum of this electron.

### Sample problem 11.4

- (a) Electrons are emitted from a surface with a kinetic energy of  $2.6 \times 10^{-19} \text{ J}$ . What is the size of the stopping voltage that will remove all of this energy from the electrons?  
 (b) What energy electrons will a 4.2 V stopping voltage stop?

**Solution:** (a) The kinetic energy of each electron is  $2.6 \times 10^{-19} \text{ J}$ . The charge on an electron is  $1.6 \times 10^{-19} \text{ C}$ .

$$\begin{aligned} E_k &= qV_0 \\ 2.6 \times 10^{-19} \text{ J} &= 1.6 \times 10^{-19} \text{ C} \times V_0 \\ V_0 &= \frac{2.6 \times 10^{-19} \text{ J}}{1.6 \times 10^{-19} \text{ C}} \\ &= 1.62 \text{ V} \\ &= 1.6 \text{ V (accurate to 2 significant figures)} \end{aligned}$$

A stopping voltage of 1.6 V will stop the electrons emitted from the surface.

- (b) The stopping voltage is 4.2 V. The charge of an electron is  $1.6 \times 10^{-19} \text{ C}$ .

$$\begin{aligned} E_k &= qV_0 \\ &= 1.6 \times 10^{-19} \text{ C} \times 4.2 \text{ V} \\ &= 6.72 \times 10^{-19} \text{ J} \\ &= 6.7 \times 10^{-19} \text{ J (accurate to 2 significant figures)} \end{aligned}$$

A stopping voltage of 4.2 V will stop electrons with energy  $6.7 \times 10^{-19} \text{ J}$ .

### Revision question 11.4

Electrons are emitted from the surface of a photocell with  $4.8 \times 10^{-19}$  J of kinetic energy. What is the size of the stopping voltage that will remove all of this energy from the electrons?

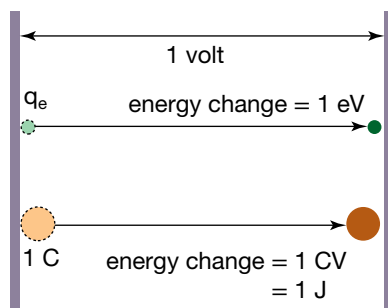

A joule and an electron volt

Remember that a joule is the electric potential energy change that occurs when one coulomb of charge moves through a potential difference of one volt.

$$1 \text{ V} = \frac{1 \text{ J}}{1 \text{ C}}$$

$$\Rightarrow 1 \text{ J} = 1 \text{ C} \times 1 \text{ V}$$

An electron volt is defined as the electric potential energy change that occurs when one electronic charge,  $q_e = 1.6021 \times 10^{-19}$  C, moves through one volt.

$$1 \text{ eV} = 1 q_e \times 1 \text{ V}$$

where

$q_e$  is the magnitude of charge of an electron

$$\Rightarrow 1 \text{ eV} = 1.6021 \times 10^{-19} \text{ C} \times 1 \text{ V}$$

$$\Rightarrow 1 \text{ eV} = 1.6021 \times 10^{-19} \text{ J.}$$

We now have some calculating tools for working with light, although it is modelled at this stage rather ambiguously as something like a particle — a localised packet with energy  $E = hf$  and momentum  $p = \frac{E}{c}$  — but propagating like a wave with speed  $c = f\lambda$ , which further implies a momentum  $p = \frac{h}{\lambda}$  for a localised packet. This localised packet, as we will see, is now known as a photon — a particle of light.

We also have some calculating tools for working with electrons, modelling them as particles. These particles have kinetic energy  $E_k = \frac{1}{2}mv^2$  and momentum  $p = mv$ . We can also write the kinetic energy in terms of the momentum:  $E_k = \frac{p^2}{2m}$ . This equation, in particular, will prove to be useful later. With the right experimental apparatus we can either give or take energy from charged particles by allowing a potential difference  $V$  to do work  $W$  on a charge  $q$  according to the equation  $W = Vq$ . Electrons can thus be accelerated or decelerated by a potential difference depending solely on the polarity of the potential difference attached to the equipment. This equipment is generically referred to as an electron gun. We are now ready to learn about the photoelectric effect and to interpret data arising from experiments.

## The photoelectric effect

The nineteenth century view of light was developed as a result of the success of the wave model in explaining refraction, diffraction and interference. The wave model did a great job!

The first signs of behaviour that could not be explained using a wave model almost went unnoticed in 1887. Heinrich Hertz was in the middle of the experimental work which would show that radio waves and light were really the same thing — electromagnetic waves. He produced radio waves with a frequency of about  $5 \times 10^8$  hertz (yes, the unit for frequency was named after him) by creating a spark across the approximately one centimetre gap between two small metal spheres. The radio waves were detected up to several hundred metres away, by the spark they excited across another air gap, this time between the pointed ends of a circular piece of wire. Hertz was able to show that the radio waves travelled at the speed of light. Although Hertz was not aware of it, this was the beginning of radio communication.

### study on

Unit 4 **Photoelectric effect**

AOS 2 Summary screen

Topic 1 and practice

Concept 3 questions

## study on

Unit 4

AOS 2

Topic 1

Concept 3

Do more

Using the photoelectric effect

Using the photoelectric effect

1. Select a metal and then select the frequency of the incident light. Note the frequency of the light from the photon gun.

2. Set the light source to emit photons from the metal.

3. Set the light source to emit photons from the metal.

electron energy eV

applied voltage V

frequency Hz

10<sup>14</sup> Hz

10<sup>15</sup> Hz

10<sup>16</sup> Hz

10<sup>17</sup> Hz

10<sup>18</sup> Hz

10<sup>19</sup> Hz

10<sup>20</sup> Hz

10<sup>21</sup> Hz

10<sup>22</sup> Hz

10<sup>23</sup> Hz

10<sup>24</sup> Hz

10<sup>25</sup> Hz

10<sup>26</sup> Hz

10<sup>27</sup> Hz

10<sup>28</sup> Hz

10<sup>29</sup> Hz

10<sup>30</sup> Hz

10<sup>31</sup> Hz

10<sup>32</sup> Hz

10<sup>33</sup> Hz

10<sup>34</sup> Hz

10<sup>35</sup> Hz

10<sup>36</sup> Hz

10<sup>37</sup> Hz

10<sup>38</sup> Hz

10<sup>39</sup> Hz

10<sup>40</sup> Hz

10<sup>41</sup> Hz

10<sup>42</sup> Hz

10<sup>43</sup> Hz

10<sup>44</sup> Hz

10<sup>45</sup> Hz

10<sup>46</sup> Hz

10<sup>47</sup> Hz

10<sup>48</sup> Hz

10<sup>49</sup> Hz

10<sup>50</sup> Hz

10<sup>51</sup> Hz

10<sup>52</sup> Hz

10<sup>53</sup> Hz

10<sup>54</sup> Hz

10<sup>55</sup> Hz

10<sup>56</sup> Hz

10<sup>57</sup> Hz

10<sup>58</sup> Hz

10<sup>59</sup> Hz

10<sup>60</sup> Hz

10<sup>61</sup> Hz

10<sup>62</sup> Hz

10<sup>63</sup> Hz

10<sup>64</sup> Hz

10<sup>65</sup> Hz

10<sup>66</sup> Hz

10<sup>67</sup> Hz

10<sup>68</sup> Hz

10<sup>69</sup> Hz

10<sup>70</sup> Hz

10<sup>71</sup> Hz

10<sup>72</sup> Hz

10<sup>73</sup> Hz

10<sup>74</sup> Hz

10<sup>75</sup> Hz

10<sup>76</sup> Hz

10<sup>77</sup> Hz

10<sup>78</sup> Hz

10<sup>79</sup> Hz

10<sup>80</sup> Hz

10<sup>81</sup> Hz

10<sup>82</sup> Hz

10<sup>83</sup> Hz

10<sup>84</sup> Hz

10<sup>85</sup> Hz

10<sup>86</sup> Hz

10<sup>87</sup> Hz

10<sup>88</sup> Hz

10<sup>89</sup> Hz

10<sup>90</sup> Hz

10<sup>91</sup> Hz

10<sup>92</sup> Hz

10<sup>93</sup> Hz

10<sup>94</sup> Hz

10<sup>95</sup> Hz

10<sup>96</sup> Hz

10<sup>97</sup> Hz

10<sup>98</sup> Hz

10<sup>99</sup> Hz

10<sup>100</sup> Hz

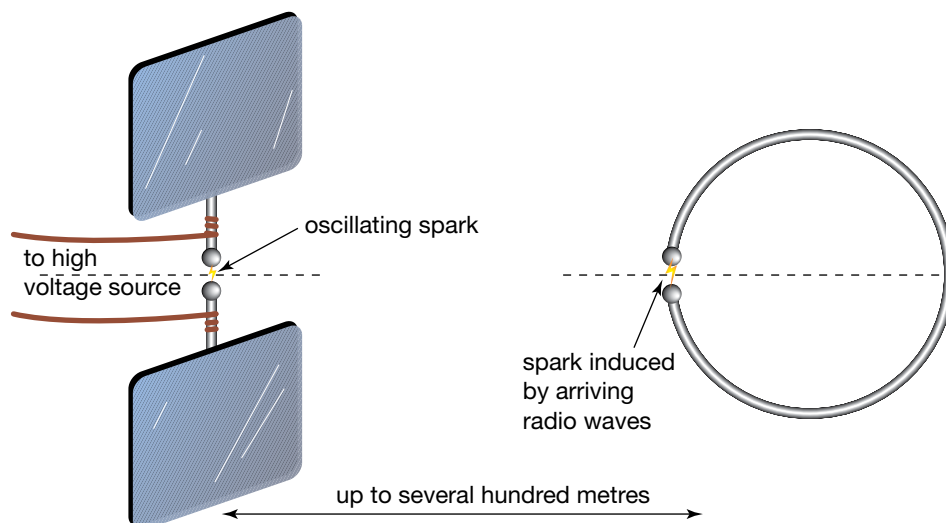

Hertz detected radio waves using the spark between two electrodes.

During his experiments Hertz noticed that the spark showing the arrival of the radio waves at the receiver became brighter whenever the gap was simultaneously exposed to ultraviolet radiation. He was puzzled, and made note of it, but did not follow it up. Now we know that the reason for the brighter spark was that the ultraviolet radiation ejected electrons from the metal points of the detector. The presence of these electrons reduced the electrical resistance of the air gap, so a spark flashed brighter than usual whenever the radio waves were being detected.

This ejection of electrons by light is called the **photoelectric effect**. Following up Hertz's observations of this effect led to a breakthrough in the way we view the behaviour of light.

## The experiment

Fifteen years passed before Philipp Lenard, a German physicist, performed careful experiments to investigate the effect. Lenard replaced Hertz's spark gap with two metal electrodes on opposite sides of an evacuated chamber. He investigated the energies of electrons ejected from one of these electrodes when light shone on it. The experimental arrangement used in 1902 by Lenard is shown overleaf, top left. Lenard designed his experiment so that he could vary several features of this arrangement.

- *The frequency and intensity of the light* could be varied. Light from an electric discharge arcing between two electrodes was introduced into the chamber through a window. The arc produced a spectrum of several different frequencies characteristic of the electrode material. Filters in front of the window were used as frequency selectors to ensure that light of a single chosen frequency reached the electrode X. Light sources that emit light of only one frequency are called **monochromatic** light sources. Lenard varied the light intensity either by changing the arc current, or by moving the light source to a different distance from the window.
- *The potential difference between the electrodes in the chamber* could be varied by changing the position of the slide contact on the coiled resistor. By varying the contact position to both right and left of Z, the potential difference could be made either accelerating or retarding for electrons.
- Lenard could vary *the distance between the electrode receiving light, X, and the second electrode, Y.*

The **photoelectric effect** is the release of electrons from a metal surface as a result of exposure to electromagnetic radiation.

**Monochromatic** describes light of a single frequency and, hence, very clearly defined colour.

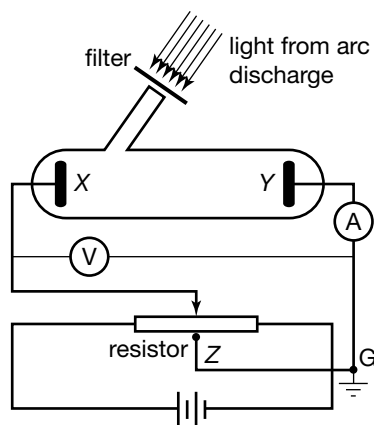

Philipp Lenard's experiment. Note that the point G is earthed, and this earths the electrode Y. Electrode X could be made either positive or negative relative to electrode Y.

### study on

Unit 4 **Photocurrent and light intensity**

AOS 2 **Photocurrent and light intensity**

Topic 1 Summary screen and practice questions

Concept 4

First, Lenard used a fixed intensity light source and a fixed accelerating voltage while he varied the distance between the electrodes. He found that the current of photoelectrons, called the photocurrent, increased to a maximum when the electrodes were about 5 mm apart. He reasoned that after being ejected by light the electrons flew out in different directions, and that at this short distance the second electrode was collecting all electrons. This separation was used for all the later experiments.

Now he was ready to explore the effects of the light on this photoelectric effect. The results of Lenard's further experiments are summarised in the graphs of photocurrent as a function of the potential difference between the electrodes for several light intensities shown below.

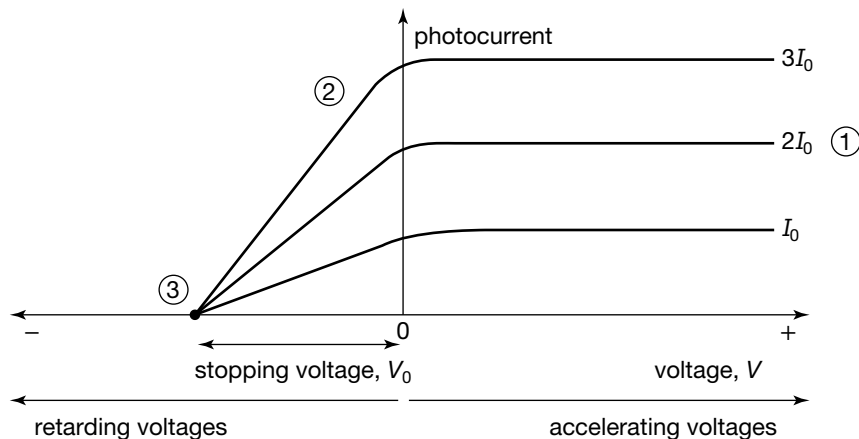

The effect of changing light intensity from  $I_0$  without changing its frequency

The graphs above illustrate several important parts of Lenard's investigations. The numbers on the diagrams refer to the numbered points below.

1. Keeping the light frequency constant, Lenard investigated how the maximum photocurrent depended on light intensity. Higher intensity light produced greater values of the maximum photocurrent, as shown in the figure above. In fact Lenard's results showed that the maximum photocurrent was directly proportional to the light intensity. To his surprise this proportionality held true over a wide intensity range, right down to light of a tiny  $3 \times 10^{-7}$  of the highest intensity light he could produce.
2. When Lenard applied a retarding voltage between the electrodes, the current decreased as the magnitude of the voltage increased. This was not surprising. It was expected that when the electric field between the plates exerted a force opposing the motion of the electrons, they would slow down and probably reverse direction before reaching the opposite electrode. The kinetic energy of the electrons would be converted into electric potential energy. Only the very slow electrons would reverse direction before being collected at the electrode Y when the voltage between the plates was low. So, only a few electrons would then be removed from the stream contributing to the photocurrent. As the magnitude of the voltage was increased, more and more electrons would turn around before reaching the electrode, until at a particular voltage no electrons completed the crossing and the current dropped to zero. This minimum voltage which causes all electrons to turn back is called the stopping voltage.
3. Lenard found that the stopping voltage did not depend on the intensity of the light being used. Brighter light *did not* increase the kinetic energy of the electrons emitted from the cathode. The same potential difference was required to convert all of the kinetic energy of the electron into electric potential energy, no matter how bright the light.

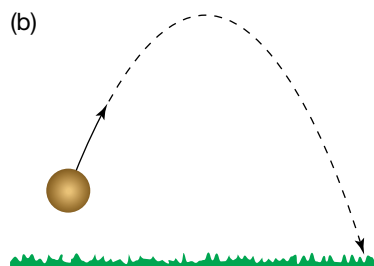
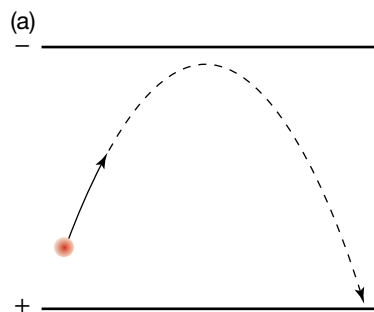

(a) An electron in an electric field opposing its motion, and (b) a ball thrown into the air

## study on

Unit 4

AOS 2

Topic 1

Concept 4

See more

Photocurrent and light intensity



## study on

Unit 4

AOS 2

Topic 1

Concept 5

**Photocurrent and frequency of light**

Summary screen and practice questions

4. The stopping voltage, however, depended on both the frequency of the light (see the following figure) and on the material of the electrode. In fact, for each material there was a minimum frequency required for electrons to be ejected. Below this cut-off frequency no electrons were ever ejected, no matter how intense the light or how long the electrode was exposed to the light. Above this frequency a photocurrent could always be detected. The photocurrent could be detected as quickly as  $10^{-9}$  s after turning on the light source. This time interval was independent of the brightness of the light source.

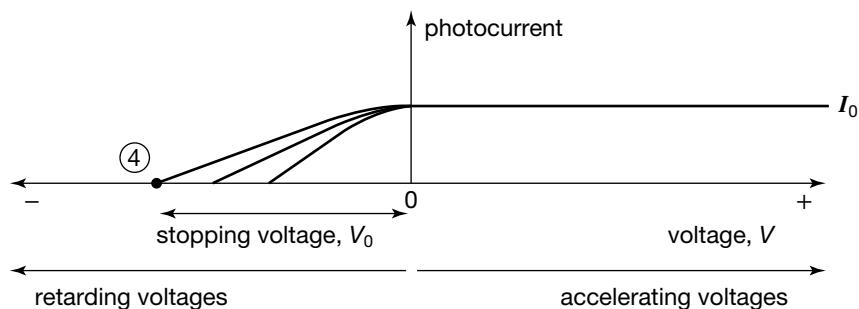

The effect of changing light frequency, without changing its intensity, on the photocurrent of one material

These experiments provided evidence that the energy of light is bundled into packets whose energy depends on the light frequency. In explaining these experiments, the behaviour of light is best described as a stream of particles — very reminiscent of Newton's view! Albert Einstein, in 1905, first proposed the model to explain the photoelectric effect. For this work he won the Nobel Prize in 1921, even though he is now better known for his theories of relativity, explaining the behaviour of objects travelling at speeds close to the speed of light. Lenard had already won the Nobel Prize in 1905 for his experimental investigations.

### Sample problem 11.5

The diagram below shows the current-versus-stopping voltage curve for a typical photoelectric cell using green light.

The colour is changed to blue, but with a lower intensity. Sketch the curve that would result from these changes.

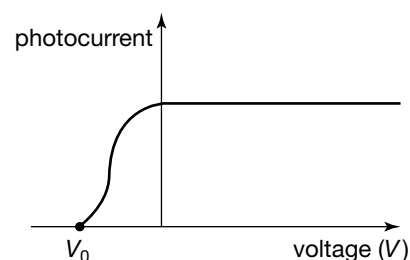

**Solution:** Because blue light has a higher frequency than green light, the stopping voltage would be greater. The lower intensity would make the photocurrent smaller. This is shown in the diagram below.

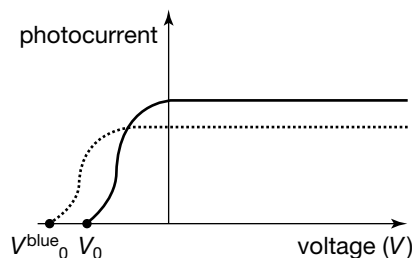

### Revision question 11.5

Consider the same arrangement as in Sample problem 11.5 except this time yellow light is used but sufficient to cause the photoelectric effect to occur. The intensity of the light is greater than with the green light. Sketch the curve that would result from this change.

To help understand Einstein's explanation of the photoelectric effect, it is helpful to have a mental picture of how the wave and particle models describe a light bulb and its intensity. We will then return to the photoelectric effect.

### The particle model view of a light bulb

A **photon** is a discrete bundle of electromagnetic radiation. Photons can be thought of as discrete packets of light energy with zero mass and zero electric charge.

The particle model describes a light bulb as an object emitting large numbers of light particles each second. These light particles are now called **photons**. The photons from a monochromatic light source all have the same energy, whereas a white light source emits photons having a range of energies. An intense monochromatic light source emits a greater number of photons per second than a dim light source emitting the same colour light.

Each photon has an energy that is characteristic of the frequency of the light. The relationship between photon energy,  $E_{\text{photon}}$ , and frequency,  $f$ , is:

$$E_{\text{photon}} = hf$$

where  $h$  is Planck's constant, named after Max Planck who first proposed that light was emitted in fixed quantities of energy related to frequency. The value of  $h$  is  $6.63 \times 10^{-34}$  J s, or  $4.15 \times 10^{-15}$  eV. Since wave speed, frequency and wavelength are related by the equation  $c = f\lambda$ , we can also write:

$$E_{\text{photon}} = \frac{hc}{\lambda}$$

where

$c$  = the speed of light in a vacuum

$\lambda$  = the wavelength of the light.

It is paradoxical that the photon energy, a particle characteristic of light, is related to wavelength, which arises from its wave behaviour.

(a) dim light source

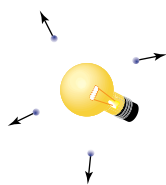

(b) more intense light source

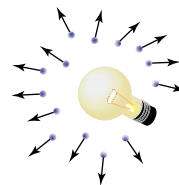

• represents a photon

(a) A dim and (b) a more intense light source. The reduced size of the art does not indicate that the photons here have been drawn as fuzzy blobs. A fuzzy blob has been used to indicate that a photon is not a particle like a billiard ball. It does not have definite edges.

### Sample problem 11.6

An electron is ejected from an atom with a kinetic energy of 1.9 eV. A retarding voltage of 1.2 V causes it to slow down during a photoelectric effect experiment (see figure below left). Describe the energy changes and calculate their values, in both eV and J.

**Solution:** Energy is transformed from kinetic energy to electric potential energy. Let  $q_e$  represent the *magnitude* of the charge on the electron. The increase in electric potential energy is:

$$\begin{aligned}\Delta E_{ep} &= -q_e V \\ &= -q_e \times -1.2 \text{ V} \\ &= 1.2 \text{ eV.}\end{aligned}$$

The electric potential energy has increased by 1.2 eV. The kinetic energy will have decreased from 1.9 eV to 0.7 eV.

Converting the unit of this increase of electric potential energy to joules:

$$\begin{aligned}1.2 \text{ eV} &= 1.2 \text{ eV} \times 1.6021 \times 10^{-19} \text{ J eV}^{-1} \\ &= 1.9 \times 10^{-19} \text{ J.}\end{aligned}$$

In one step:

$$\begin{aligned}\Delta E_{ep} &= -q_e V \\ &= -1.6021 \times 10^{-19} \text{ C} \times -1.2 \text{ V} \\ &= 1.9 \times 10^{-19} \text{ J.}\end{aligned}$$



### Revision question 11.6

An electron is ejected from an atom with kinetic energy  $E$ . A retarding voltage of 1.8 V causes it to slow down so that its kinetic energy is 0.50 eV.

- Calculate the initial kinetic energy  $E$  of the electron in eV.
- Convert this energy into joules.

### Sample problem 11.7

The energy of a photon of 515 nm light is  $3.86 \times 10^{-19}$  J. How many eV is that?

**Solution:** To convert energy in J to eV, divide by  $1.6021 \times 10^{-19} \text{ J eV}^{-1}$ .

$$\begin{aligned}3.86 \times 10^{-19} \text{ J} &= \frac{3.86 \times 10^{-19} \text{ J}}{1.6021 \times 10^{-19} \text{ J eV}^{-1}} \\ &= 2.41 \text{ eV}\end{aligned}$$

Clearly the eV unit is much more convenient.

### Revision question 11.7

What is the energy in joules of a photon whose energy is 13.6 eV?

## A wave model view of a light bulb

Now we turn to thinking about a light bulb as a source of waves. The waves are moving oscillations of linked electric and magnetic fields, as shown in the figure on page 2. Spherical wavefronts spread out from the light bulb. If the light bulb is monochromatic, it emits light of a single frequency, and because all light travels at the same speed in a vacuum this frequency determines the



wavelength. The intensity of the light affects the amplitude of the wave, not its frequency. When more intense light passes a point there is a greater difference between the maximum and minimum values of the electric field, and the magnetic field, occurring at that point as the light passes.

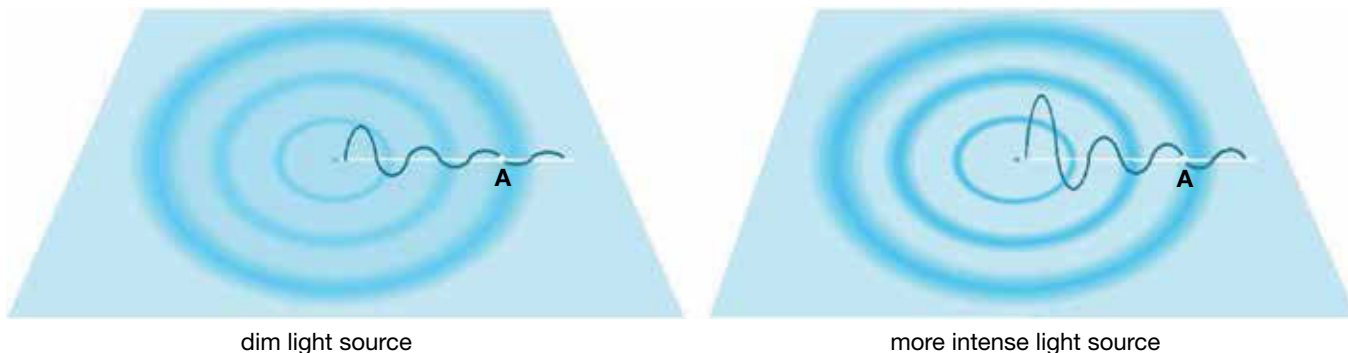

At the point A, the variation in the electric field with time is:

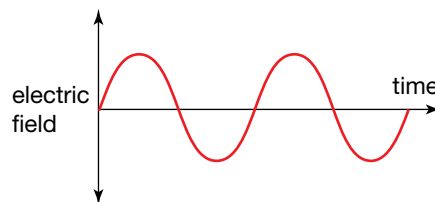
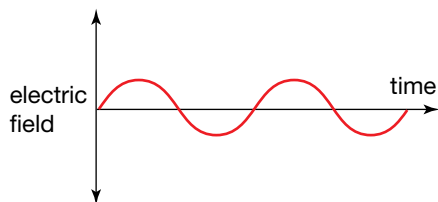

Wave model of two light sources emitting light of the same frequency but with different intensities. Imagine a water surface being regularly disturbed by an object dipping into the water. The water level could represent the electric field of the light wave.

## The particle model and the photoelectric effect

Now that we have an idea of the wave and particle model descriptions of intensity, let's consider how each of the observations of the photoelectric effect experiment could be explained using a particle model, and why a wave model is not as successful in this situation. Remember, a close inspection of the evidence should be able to allow us to decide whether electrons are being hit by particles or waves.

The next figure illustrates the two models. In both models light transfers energy to the electrons, enabling them to escape from the overall attractive force exerted by the metal electrode. In the particle model description, the entire energy of a *single* photon is transferred to a *single* electron; the photon is gone. (One photon — two electron processes are very rare.) Some of the photon energy is required to enable the electron to escape from the electrode. This transferred energy, which enables an electron to escape the attraction of a material, is called its **ionisation energy**. Electrons in the metal have a range of energy levels, so they also have a range of ionisation energies. The minimum ionisation energy is called the **work function** of the material. The photon energy which is 'left over' becomes the kinetic energy of the electron. Naturally, the electrons requiring the least energy to enable them to escape will leave with the greatest kinetic energy.

**Ionisation energy** is the amount of energy required to be transferred to an electron to enable it to escape from a material.

The **work function** is the minimum energy required to release an electron from the surface of a material.

**Weblink**

The photoelectric effect

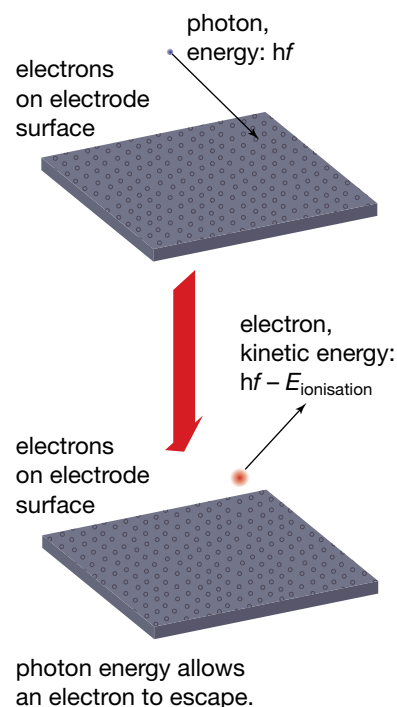
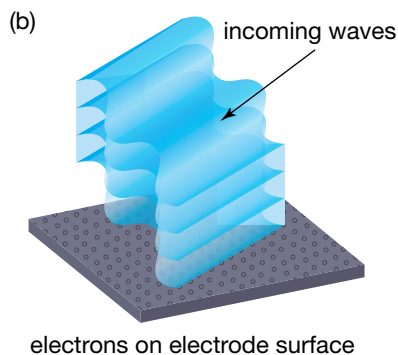
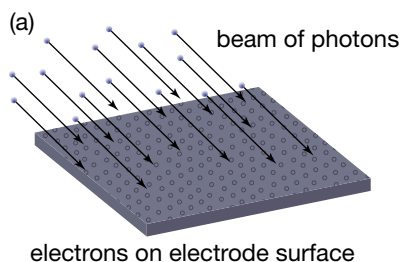

(a) A particle model and (b) a wave model of light intensity

The kinetic energy of each photoelectron is given by:

$$E_k = E_{\text{photon}} - E_{\text{ionisation}} = hf - E_{\text{ionisation}}$$

The maximum kinetic energy of photoelectrons,  $E_{k\text{max}}$ , is given by:

$$E_{k\text{max}} = E_{\text{photon}} - W = hf - W$$

where  $W$  is the work function.

**study on**

- Unit 4 **Graphs of  $E_{k\text{max}}$  versus frequency**
- AOS 2
- Topic 1 Summary screen and practice questions
- Concept 9

### An energy perspective

An energy picture of the effect can also be useful. Note that the vertical axis in the figure below is *not* the depth of the electron in the material, but the electron energy. Electrons in the metal have a range of energies, depending on how strongly they are bound to the metal. Electrons having higher energies are more loosely held by the material and need to receive less energy to escape than electrons at lower energy.

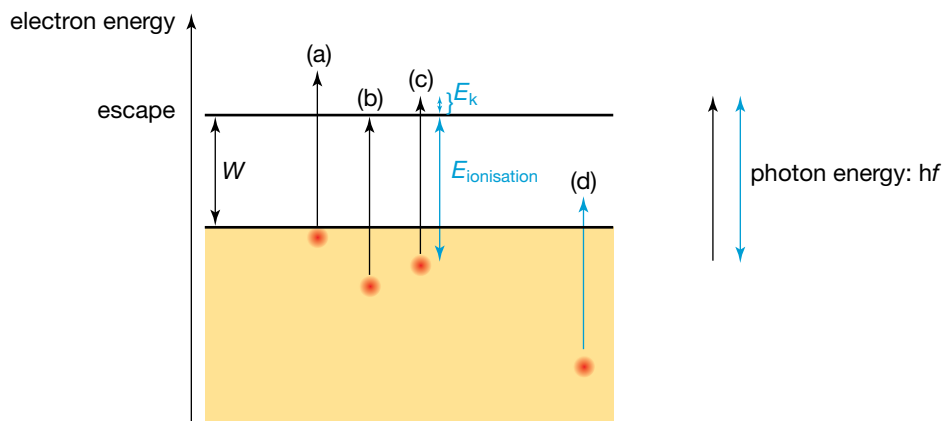

Four identical photons deliver their energy to four electrons. (a) Electron escapes, with maximum  $E_k = hf - W$ . (b) Photon energy is just enough for electron to escape, but electron  $E_k$  is zero. (c) Electron escapes, with  $E_k = hf - E_{\text{ionisation}}$ ;  $E_k < \text{maximum } E_k$ . (d) Photon energy is insufficient to enable electron to escape.

## study on

Unit 4

AOS 2

Topic 1

Concept 9



See more

Graphing the photoelectric effect

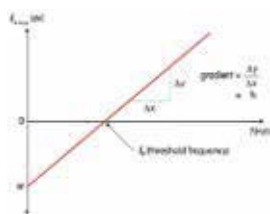

## Explaining Lenard's experimental observations

Here is how the particle model explains Lenard's experimental observations. The numbering here matches the number of these observations earlier in the chapter. (See pages 12–13.)

1. *Maximum photocurrent is proportional to intensity.*

Doubling the intensity without changing frequency doubles the number of photons reaching the electrode each second, but not their energy. This doubles the rate of electron emission without changing the energy transferred to each electron, and therefore doubles the maximum photocurrent.

2. *Retarding voltage reduces photocurrent. A stopping voltage exists above which no electrons reach the second electrode.*

Ejected electrons have a variety of energies, depending on the photon energy and their ionisation energy. A low retarding voltage turns back only the electrons having low kinetic energies. Increasing the retarding voltage will turn back electrons with higher kinetic energies, until at the stopping voltage none can reach the second electrode.

3. *Stopping voltage is independent of light intensity.*

Changing the light intensity only does not change its frequency, so the photon energy is not changed. Photoelectrons will have the same range of energies, and so the same retarding voltage is needed to reduce the photocurrent to zero.

4. *Stopping voltage depends on light frequency and material: a cut-off frequency exists.*

Since the stopping voltage reverses the direction of *all* electrons, it is the voltage required to entirely transform the kinetic energy of the fastest electrons into electric potential energy.

$$E_{k\max} = \text{magnitude of change in electron's electrical potential energy} \\ = q_e V_0$$

where  $q_e$  here is the *magnitude* of the electronic charge.

Our photon model tells us that:

$$E_{k\max} = E_{\text{photon}} - W \\ = hf - W$$

$$\text{So } q_e V_0 = hf - W.$$

Clearly  $V_0$  depends on the light frequency,  $f$ , and also on the electrode material through its work function,  $W$ . A photon whose energy,  $hf$ , is less than the work function,  $W$ , cannot supply enough energy for an electron to escape. The electron remains trapped by the electrode.

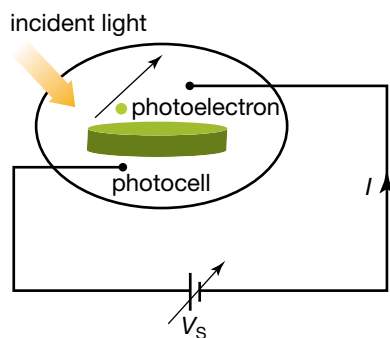

Schematic of a simple photocell

### Sample problem 11.8

Light with a wavelength of 425 nm strikes a clean metallic surface and photoelectrons are emitted. A voltage of 1.25 V is required to stop the most energetic electrons emitted from the photocell.

- Calculate the frequency of a photon of light whose wavelength is 425 nm.
- Calculate the energy in joules and also in electron volts of a photon of light whose wavelength is 425 nm.
- State the energy of the emitted electron in both electron volts and joules.
- Calculate the work function  $W$  of the metal in eV and J.
- Determine threshold frequency  $f_0$  and consequently the maximum wavelength of a photon that will just free a surface electron from the metal.

- (f) Light of a wavelength 390 nm strikes the same metal surface. Calculate the stopping voltage.

**Solution:** (a) 
$$f = \frac{c}{\lambda}$$
$$= \frac{3.0 \times 10^8}{4.25 \times 10^{-7}}$$
$$= 7.06 \times 10^{14} \text{ Hz}$$
$$= 7.1 \times 10^{14} \text{ Hz}$$

(b) 
$$E = hf$$
$$= 6.63 \times 10^{-34} \times 7.06 \times 10^{14}$$
$$= 4.68 \times 10^{-19} \text{ J}$$

To convert energy in joules into energy in electron volts, divide by  $1.6 \times 10^{-19}$  joules  $\text{eV}^{-1}$ .

$$E = \frac{4.68 \times 10^{-19}}{1.6 \times 10^{-19}}$$
$$= 2.92 \text{ eV}$$
$$= 2.9 \text{ eV}$$

- (c) Since the stopping voltage is 1.25 V, the energy of the emitted electron is 1.25 eV. The energy in joules can be found by multiplying by  $1.6 \times 10^{-19}$ . Thus the energy is:

$$1.25 \times 1.6 \times 10^{-19} = 2.00 \times 10^{-19} \text{ J.}$$

- (d) Using the equation  $E_{k_{\max}} = hf - W$ , the work function can be found. We know that when the photon energy  $hf$  equals 2.92 eV the electrons have an energy of 1.25 eV. Thus  $1.25 = 2.92 - W$ . Thus:

$$W = 2.92 - 1.25 = 1.67 \text{ eV} = 2.67 \times 10^{-19} \text{ J} = 2.7 \times 10^{-19} \text{ J.}$$

- (e) Again use the equation  $E_{k_{\max}} = hf - W$ . The threshold frequency  $f_0$  is the frequency below which the photoelectric effect does not occur. At this frequency electrons are just not able to leave the surface. This model implies  $0 = hf_0 - W$ . Rearrange this equation to give the useful result:

$$f_0 = \frac{W}{h}$$
$$= \frac{2.67 \times 10^{-19}}{6.63 \times 10^{-34}}$$
$$= 4.03 \times 10^{14} \text{ Hz.}$$

The maximum wavelength is thus:

$$\lambda = \frac{c}{f_0}$$
$$= \frac{3.0 \times 10^8}{4.03 \times 10^{14}}$$
$$= 7.4 \times 10^{-7} \text{ m or } 740 \text{ nm.}$$

- (f) Use the equation  $E_{k_{\max}} = h\frac{c}{\lambda} - W$  to find the energy of the emitted electrons. When this is known the stopping voltage can be readily found. It is convenient to use eV here.

$$\begin{aligned} E_{k_{\max}} &= \frac{4.15 \times 10^{-15} \times 3.0 \times 10^8}{3.90 \times 10^{-7}} - 1.67 \\ &= 3.19 - 1.67 \\ &= 1.52 \text{ eV} \\ &= 1.5 \text{ eV} \end{aligned}$$

A stopping voltage of 1.5 V is required to stop the emitted electrons.

### Revision question 11.8

A new photocell with a different metallic surface is used. Again light of wavelength 425 nm strikes a clean metallic surface and photoelectrons are emitted. This time, a stopping voltage of 0.87 V is required to stop the most energetic electrons emitted from the photocell.

- State the highest energy of the emitted electrons in both electron volts and joules.
- Calculate the work function  $W$  of the metal.
- Determine threshold frequency  $f_0$  and, consequently, the maximum wavelength of a photon that will just free a surface electron from the metal.
- Light of a wavelength 650 nm strikes the same metal surface. Explain what happens.

### Sample problem 11.9

The table below gives some data collected by students investigating the photoelectric effect using a photocell with a lithium cathode. This cell is illustrated in the schematic diagram on the left.

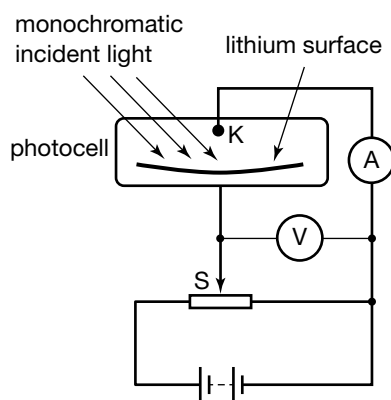

Wavelength of light used (nm)	Frequency of light used $\times 10^{14}$ (Hz)	Photon energy of light used, $E_{\text{photon}}$ (eV)	Stopping voltage readings (V)	Maximum photo-electron energy $E_e$ (J)
663			0.45	
	6.14			$1.84 \times 10^{-19}$

- Complete the table.
- Using only the two data points supplied in the table, plot a graph of maximum photo-electron energy in joules versus photon frequency in hertz for the lithium photocell.
- Using only your graph, state your values for the following quantities. In each case, state what aspect of the graph you have used.
  - Planck's constant,  $h$ , in the units J s and eV s as determined from the graph
  - The threshold frequency,  $f_0$ , for the metal surface in Hz as determined from the graph
  - The work function,  $W$ , for the metal surface as determined from the graph, in the units J s and eV s
- On the same axes, draw and label the graph you would expect to get when using a different photocell, given that it has a work function slightly larger than the one used to collect the data in the table above.

A new photocell is now investigated. When light of frequency  $9.12 \times 10^{14}$  Hz is used, a stopping voltage of 1.70 V is required to stop the most energetic electrons.

- (e) Calculate the work function of the new photocell, giving your answer in both joules and electron volts.
- (f) When the battery voltage of the new photocell is set to 0 V, the photocurrent is measured to be  $48 \mu\text{A}$ . The intensity of the light is now doubled. Describe what happens in the electric circuit with the power supply voltage set to 0 V when the light intensity is doubled.
- (g) With the intensity still doubled, the voltage is now slowly increased from 0 and the photocurrent slowly reduces to 0 A. State the stopping voltage when the current first equals 0 A with the light intensity still doubled.

**Solution:** (a) Use  $c = f\lambda$  to complete columns 1 and 2. Use  $E = hf$  to complete column 3, and use the conversion factor for joules to eV to complete columns 4 and 5.

Wavelength of light used (nm)	Frequency of light used $\times 10^{14}$ (Hz)	Photon energy of light used, $E_{\text{photon}}$ (eV)	Stopping voltage readings (V)	Maximum photo-electron energy $E_e$ (J)
663	4.52	1.88	0.45	$7.20 \times 10^{-20}$
488	6.14	2.55	1.15	$1.84 \times 10^{-19}$

- (b) The graph will contain two points representing the fact that light of frequency  $4.52 \times 10^{14}$  Hz will produce electrons of energy 0.45 eV and light of frequency  $6.52 \times 10^{14}$  Hz will produce electrons of energy 1.15 eV. A line drawn containing these two data points will give a work function of 1.5 eV and a threshold frequency of  $3.5 \times 10^{14}$  Hz.

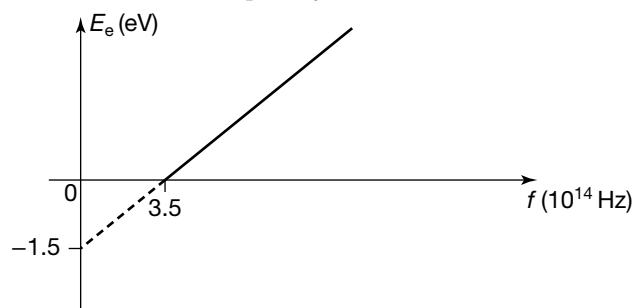

- (c) (i) Planck's constant = gradient of graph

$$= \frac{1.84 \times 10^{-19} - 7.20 \times 10^{-20}}{(6.14 - 4.52) \times 10^{14}} = 6.9 \times 10^{-34} \text{ J s},$$

which is close to the accepted value. It also has the value  $4.3 \times 10^{-15}$  eV s.

- (ii) From the line of best fit in graph (b), the threshold frequency = x-axis intercept =  $3.5 \times 10^{14}$  Hz.
- (iii) From the line of best fit in the graph (b), the work function = y-axis intercept =  $2.4 \times 10^{-19}$  J = 1.5 eV.

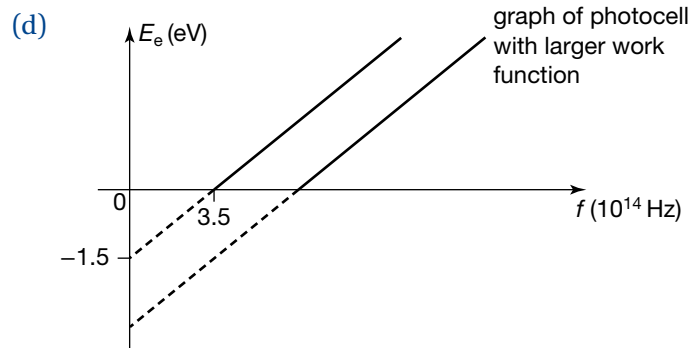

- (e) Use  $E_e = E_{\text{photon}} - W$  to calculate the work function,  $W$ .
- $$1.7 \times 1.6 \times 10^{-19} = 6.6 \times 10^{-34} \times 9.12 \times 10^{14} - W$$
- $$W = 6.02 \times 10^{-19} - 2.72 \times 10^{-19}$$
- $$= 3.3 \times 10^{-19} \text{ J}$$
- $$= 2.1 \text{ eV}$$
- (f) With the light intensity doubled, the photocurrent would also double.
- (g) The stopping voltage would remain the same, 1.7 V, as the colour and hence the frequency of the light source is unchanged.

### Revision question 11.9

The table below gives some data collected by students investigating the photoelectric effect using a photocell with a clean metallic cathode.

Wavelength of light used (nm)	Frequency of light used $\times 10^{14}$ (Hz)	Photon energy of light used, $E_{\text{photon}}$ (eV)	Stopping voltage readings (V)	Maximum photo-electron energy $E_e$ (J)
		3.19		$3.78 \times 10^{-19}$
524			1.54	

- (a) Complete the table.
- (b) Using only the two data points supplied in the table, plot a graph of maximum photo-electron energy in joules versus photon frequency in hertz for the photocell.
- (c) Using only your graph, state your values for the following quantities. In each case, state what aspect of the graph you have used.
- Planck's constant,  $h$ , in the units J s and eV s as determined from the graph
  - The threshold frequency,  $f_0$ , for the metal surface in Hz as determined from the graph
  - The work function,  $W$ , for the metal surface as determined from the graph, in the units J s and eV s
- (d) On the same axes, draw and label the graph you would expect to get when using a different photocell, given that it has a work function slightly larger than the one used to collect the data in the table above.

A new photocell is now investigated. When light of frequency  $8.25 \times 10^{14}$  Hz is used, a stopping voltage of 1.59 V is required to stop the most energetic electrons. In addition, when the battery voltage is set to 0 V, the photocurrent is measured to be 38  $\mu$ A.

- (e) Calculate the work function of the new photocell.
- (f) Describe what happens in the electric circuit with the power supply voltage set to 0 V when the light intensity is halved.
- (g) With the intensity still halved, the stopping voltage is now slowly increased from 0 V and the photocurrent slowly reduces to 0 A. State the stopping voltage when the current first equals 0 A with the light intensity still halved.

### study on

Unit 4

AOS 2

Topic 1

Concept 6

**Failure of the wave model**

Summary screen and practice questions

## What's wrong with the wave model?

In the wave model picture of the photoelectric effect, the energy of light is shared between electrons and accumulated little by little with the arrival of each wavefront. If this were true, the photoelectric effect experiment results would be significantly different.

Higher intensity light, delivering energy at a greater rate, would produce electrons with higher kinetic energies, so the stopping potential difference would depend on intensity.

For example, the effect of waves on a beach is cumulative. As each wave breaks along the length of the beach, it adds to the effect of the previous waves until signs of erosion appear.

There would be a time delay while enough shared energy accumulated for electrons to escape, and this delay would be shorter for higher intensity light.

There would be no lower limit on the frequency of light which could eject electrons. The waiting time for electrons to emerge would be longer using lower frequency light, since its wavefronts arrive less frequently; however, eventually a current would be detected.

**eBookplus**

**Weblink**

Explaining the photoelectric effect

## Great photoelectric effect results

Einstein's insights into using a particle model to explain the photoelectric effect led to his 1905 prediction. He predicted that a graph of stopping voltage versus frequency would be a straight line whose gradient was independent of the material emitting electrons.

$$V_0 = \frac{1}{q_e}(hf - W)$$

A 'machine shop in a glass tube' was needed to show that this prediction was correct. Robert Millikan, the same Millikan who had earlier measured the minimum value of electric charge, was the engineer of this machine shop, which is shown below. Strong monochromatic UV sources did not exist, so Millikan used the visible and near-UV lines of a mercury arc lamp. Since the visible and near-UV photons of the lamp have lower energy than UV photons, his studies were limited to materials with low work functions. He used the alkali metals: lithium, sodium and potassium.

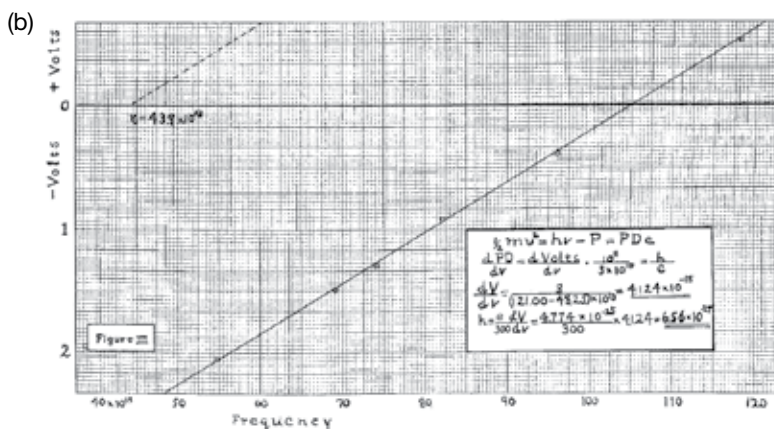
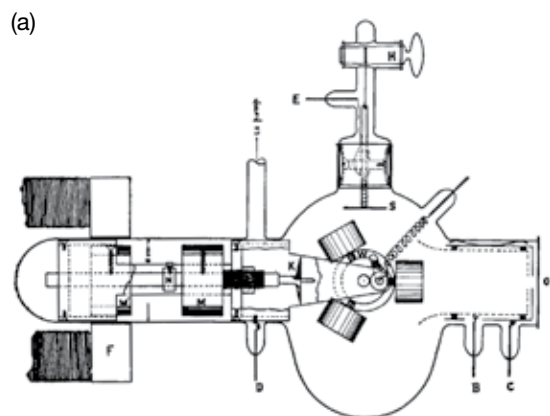

(a) Millikan's 'machine shop in a glass tube', and (b) his first published results

Unfortunately, while a low work function makes their electrons accessible to visible light, it also made these materials vulnerable to reaction with the oxygen in air. The metals quickly become coated with a thin insulating layer of metal oxide. To overcome this problem, Millikan conducted his experiments in an evacuated glass container. Inside the container he placed an ingenious mechanism for rotating his electrodes past a sharp knife that scraped a clean metal surface for each experiment.

Part (a) of the above figure shows his experimental arrangement and part (b), his first published results. The gradient of the straight line is  $\frac{h}{q_e}$ , where  $h$  is Planck's constant and  $q_e$  is the magnitude of the electronic charge. Millikan determined  $\frac{h}{q_e}$  to be  $4.1 \times 10^{-15} \text{ J s C}^{-1}$ .



The graphs for different materials all have the same slope,  $\frac{h}{q_e}$ , but are displaced to the right or left, depending on the work function. The cut-off frequency,  $f_0$ , is where the line meets the frequency axis. Its value is equal to  $\frac{W}{h}$ .

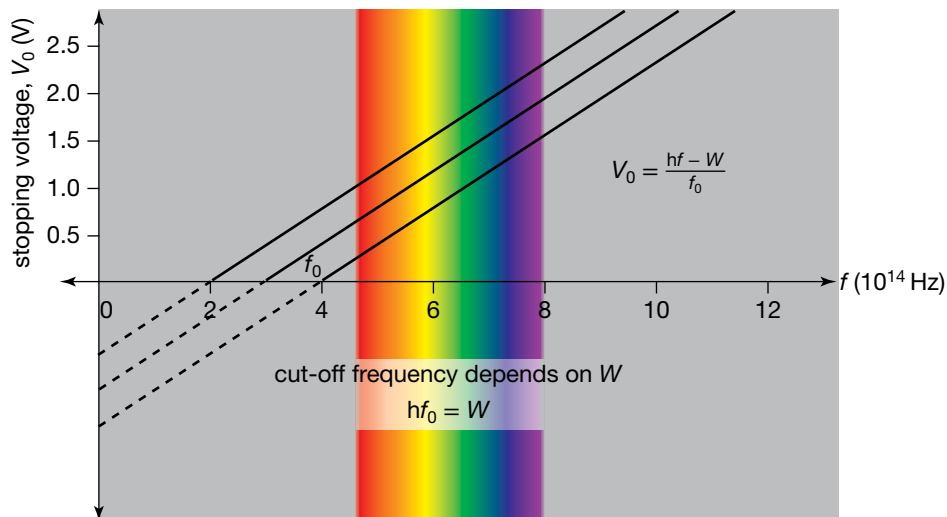

$V_0$  versus  $f$  for three different metals

### eBookplus

#### eModelling

Photoelectric effect  
doc-0042

Einstein said:

*It seems to me that the observations associated with . . . the photoelectric effect, and other related phenomena . . . are more readily understood if one assumes that the energy of light is discontinuously distributed through space . . . the energy of a light ray spreading out from a point is not continuously spread out over an increasing space, but consists of a finite number of energy quanta which are localised at points in space, which move without dividing, and which can only be produced and absorbed as complete units.*

A **quantum** is a small quantity of a fixed amount.

The word *quanta* is plural for **quantum**, a word meaning a small quantity of a fixed amount. These energy quanta of light are what we now call photons.

This need for a photon model to explain the workings of the photoelectric effect fitted very neatly with Planck's black body radiation model, in which a particle model for light was required to make the theory fit with the experimental evidence of light radiated from hot objects. However, both these phenomena contradicted the enormously successful wave model for light summarised by Maxwell's four equations for electromagnetic phenomena. The wave model for light in terms of perpendicular electric and magnetic fields is consistent with observed interference patterns and diffraction patterns, and with the propagation of light at a single speed universal speed,  $c$ . A wave model for light is also consistent with a large range of electrical and magnetic phenomena, for example electromagnetic induction.

Another chapter in physics was about to begin. The development of quantum mechanics would completely change the way in which scientists viewed the universe. The Newtonian mechanistic world was about to be overthrown. Confusion between particle and wave models for both light and matter would be resolved, but this would take another thirty years to achieve.

Solar cells

Telephone installations in remote locations extract energy from the Sun using technology based on the transfer of photon energy to electrons. They use solar cells to convert solar energy to electric energy. This is achieved by photons transferring their energy to electrons so that they are able to conduct electricity.

Solar cells are made using semiconductors like silicon. In semiconductors only about 1 in  $10^6$  of the electrons have sufficient energy to be conduction electrons. In metals like silver this figure is about 1 in 30.

Conduction electrons are not bonded to any particular atom in the crystal. They can travel through the material when a potential difference is applied across it, producing an electric current.

The vital part of a solar cell is a sandwich of two different types of impure semiconductor material, called n-type and p-type. The sandwich slivers are only tens of microns thick. Electrons drift from the n-type material, containing electrons that are not attached to any particular atom, to the p-type material, where there are spaces for electrons in the bonding structure. This creates an electric field in the layer of material very close to the boundary between the two types, with the electrons in stable positions in the bonding structure of the semiconductor material.

When the electric circuit containing this cell is in the dark, the electric field has no effect; but in the sunshine photons stream into the cell.

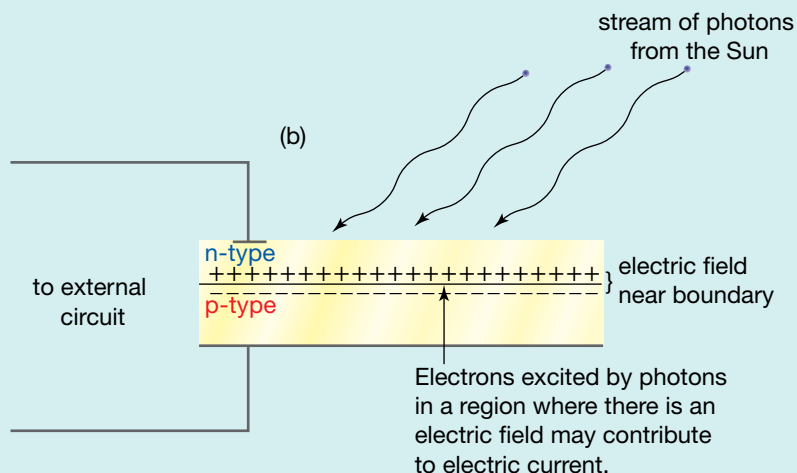
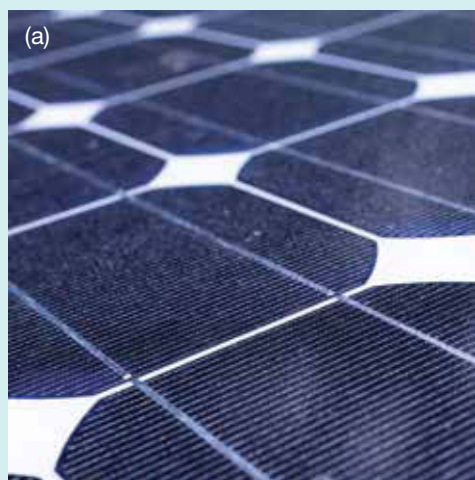

(a) Photoelectric cells, and (b) the structure of a photovoltaic cell

If a photon has sufficient energy, then it can knock an electron out of its niche in the material, enabling it to become a conduction electron and leaving a hole behind in the bonding structure. If this occurs within the region where there is an electric field, the electric force sweeps the electron through the cell, and through the circuit, contributing to the electric current.

The efficiency of a solar cell is limited by many factors. If its surface is too shiny, photons are reflected, so the surfaces are usually roughened. The sun's spectrum itself limits how well the cell can make use of the photons. In silicon, a transfer of 1.1 eV is needed to transform a bound electron into a conduction electron. This corresponds to a wavelength of  $1.1 \times 10^{-6}$  m, just into the infra-red part of the spectrum. Photons having energy less than 1.1 eV pass straight through a simple silicon cell because their energy is too small to convert bound electrons into conduction electrons.

Solar cells convert energy of photons of this radiation into electrical energy.

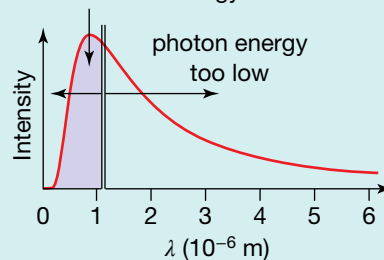

Only some of the photons of sunlight are of use to a silicon solar cell.

**study on**

**Unit 4** **Photon model of light**  
**AOS 2** Summary screen and practice questions  
**Topic 1**  
**Concept 7**

## A photon model for the photoelectric effect

Almost thirty years after the first observation of the photoelectric effect, experimental measurements confirmed the need for a photon model for light. The wave model for light was incapable of explaining the observations of the photoelectric effect.

**TABLE 11.1** Timeline of key discoveries about the photoelectric effect

Date	Event
1887	It all started with Hertz carefully noting the unusual behaviour of sparks across the gaps in his radio wave detector circuit. This was the first observation of the photoelectric effect.
1901	Max Planck solves the black-body radiation problem theoretically, paving the way for light to be modelled not only as a wave but also as a localised particle with energy proportional to the frequency of the light, $f$ .
1902	Philipp Lenard carried out experiments to accumulate knowledge about the behaviour of electrons emitted by light. There were several puzzling aspects to his results — electron energies did not depend on the light intensity and there was a unique cut-off frequency for each material.
1905	The flash of insight was Albert Einstein's, when he realised that all of Lenard's observations could be explained if he changed the way he thought about light — if light energy travelled as particles not waves. He used the particle model to predict that the graph of stopping voltage versus frequency would be straight, with a slope that was the same for all electron emitters.
1915	Robert Millikan sealed the success of Einstein's theory with plots of $V_0$ versus $f$ for the alkali metals that were straight and parallel to one another. He used the plots to measure Planck's constant. The photon energy was $hf$ .

**study on**

**Unit 4** **Photon model explanation of the photoelectric effect**  
**AOS 2** Summary screen and practice questions  
**Topic 1**  
**Concept 8**

**TABLE 11.2** Observations made from the photoelectric effect and model predictions

Observation	Wave model prediction	Photon model prediction
For a given frequency of light, the photocurrent is dependent in a linear fashion on the brightness or intensity of light.	The wave model makes no significant predication other than that brighter light should produce electrons with greater energy, which is not the case.	Intensity of light relates to the number of photons per second striking the photocell. We would expect the photocurrent to be dependent on the intensity of light.
The energy of photoelectrons is independent of intensity of light and only linearly dependent on frequency.	The energy of electrons is dependent on the intensity of light: the bigger the amplitude of the wave, the larger the energy transferred to electrons.	The energy of photoelectrons is linearly dependent on the frequency of light, provided we interpret the energy of a single photon of light as equal to $hf$ .
There is no significant time delay between incident light striking a photocell and subsequent emission of electrons, and this observation is independent of intensity.	Time delay to be shorter with increasing intensity	No time delay expected as individual photons of light strike photocell and transfer energy to individual electrons
There exists a threshold frequency below which the photoelectric effect does not occur, and this threshold is independent of intensity.	No threshold effect should exist, as energy transfer to electrons from light source is accumulative and eventually emission will occur.	A threshold frequency is predicted, as photons with energy less than the work function are incapable of freeing electrons from the photocell.



# Chapter review

## Summary

- The equation  $c = f\lambda$  describes the speed of a wave in terms of its frequency,  $f$ , and wavelength,  $\lambda$ .
- The photoelectric effect is the emission of electrons from materials, usually metals, by the action of light.
- The photoelectric effect is best explained by considering light as consisting of a stream of particles called photons. Each photon has an energy,  $E$ , that is dependent on only the frequency of the light,  $f$ , according to the equation  $E = hf$ . This is the Einstein interpretation of the photoelectric effect.
- The electron volt is a unit of energy.

$$1 \text{ eV} = 1.6 \times 10^{-19} \text{ J}$$

- When a photon hits an electron in a metal, it will transfer either all or none of its energy to an electron. This occurs within a time interval of typically  $10^{-9}$  s of a beam of light striking a surface.
- Below a threshold frequency  $f_0$ , the emission of electrons does not occur regardless of the intensity of light.
- The maximum kinetic energy of emitted electrons,  $E_{k\text{max}}$ , is given by the equation  $E_{k\text{max}} = hf - W$ , where  $f$  is the frequency of the light and  $W$  is the work function of the material.
- The maximum kinetic energy of the electrons emitted because of the photoelectric effect can be determined by measuring the stopping voltage,  $V_0$ .

$$E_{k\text{max}} = qV_0$$

- The intensity of light has no effect on the stopping voltage but only effects in direct proportion the size of the photocurrent. A wave model for light cannot account for this, but a particle model of light can.
- A graph of the maximum kinetic energy of emitted electrons plotted against frequency gives a straight line. The gradient of the graph is Planck's constant,  $h$ . The  $y$ -intercept is the work function,  $W$ , and the  $x$ -intercept is the threshold frequency,  $f_0$ .
- The photoelectric effect is strong evidence for light consisting of a stream of particles.

- Photons have momentum,  $p$ , given by the equation  $p = \frac{h}{\lambda}$ , where  $\lambda$  is the wavelength of the photon.

## Questions

### Electromagnetic radiation

1. The light from a red light-emitting diode (LED) has a frequency of  $4.59 \times 10^{14}$  Hz.
  - (a) What is the wavelength of this light?
  - (b) What is the period of this light?
2. We can detect light when our eye receives as little as  $2 \times 10^{-17}$  J. How many photons of green light is this?
3. Fill in the gaps in table 11.3 with the missing wavelength, frequency, photon energy and photon momentum values for the five different sources of electromagnetic radiation.
4. A red laser emitting 600 nm light and a blue laser emitting 450 nm light emit the same power. Compare their rate of emitting photons.

### The photoelectric effect

5. The diagram below shows a cathode, several electrons that have been ejected from the cathode by light, and an anode. The electrons leaving the cathode surface have been labelled with their kinetic energy and their initial velocity vector. The anode is 5 mm from the cathode.

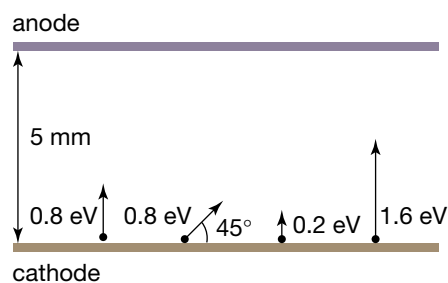

- (a) What is the speed of the electrons which have a kinetic energy of 0.8 eV?

Copy the diagram and sketch the path you would expect each electron to take for each of the potential differences,  $V$ , in parts (b) to (d) on the next page.

TABLE 11.3 Characteristics of various light sources

	Source	Wavelength	Frequency	Energy	Momentum
(a)	Infra-red from CO <sub>2</sub> laser	10.6 μm			
(b)	Red helium-neon laser			1.96 eV	
(c)	Yellow sodium lamp				$1.125 \times 10^{-27} \text{ kg m s}^{-1}$
(d)	UV from eximer laser		$1.55 \times 10^{15} \text{ Hz}$		
(e)	X-rays from aluminium			$2.01 \times 10^{-16} \text{ J}$	

- (b)  $V = 1.8 \text{ V}$ , with the anode positive relative to the cathode
- (c)  $V = 1.8 \text{ V}$ , with the anode negative relative to the cathode
- (d)  $V = 0.8 \text{ V}$ , with the anode negative relative to the cathode.
6. What is the stopping voltage when UV radiation having a wavelength of  $200 \text{ nm}$  is shone onto a clean gold surface? The work function of gold is  $5.1 \text{ eV}$ .
7. In the following diagram, the curve shows how the current measured in a photoelectric effect experiment depends on the potential difference between the anode and cathode.

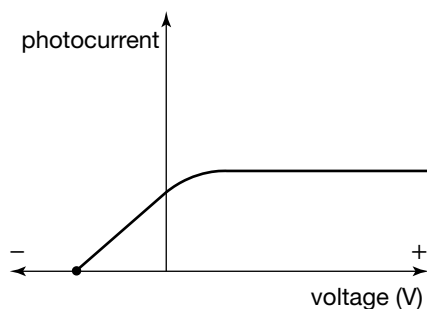

- (a) Explain the curve. Why does it reach a constant maximum value at a certain positive voltage, and why does it drop to zero at a certain negative voltage?
- (b) If the intensity of the light was increased without changing its frequency, sketch the curve that would be obtained. Explain your reasoning.
- (c) If the frequency of the light was increased without changing its intensity, sketch the curve that would be obtained. Explain your reasoning.
- (d) If the material of the cathode was changed, but the light was not changed in any way, sketch the curve that would be obtained. Explain your reasoning.
8. The curve below shows the current in a photoelectric cell versus the potential difference between the anode and the cathode when blue light is shone onto the anode.

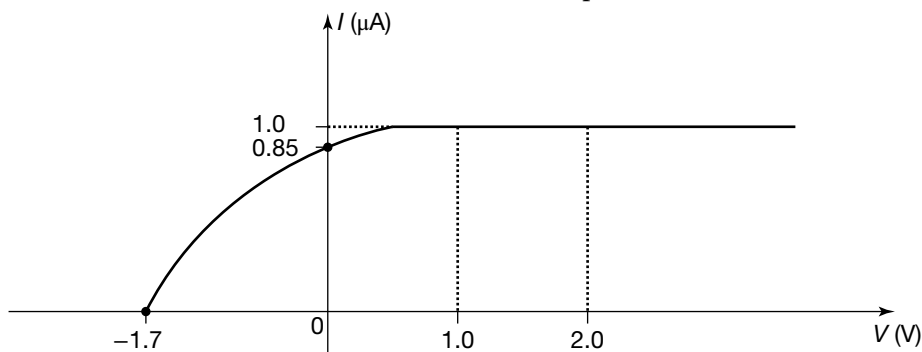

- (a) State the current when the voltage is  $0 \text{ V}$ .
- (b) State the current when the voltage is  $+1.0 \text{ V}$ .
- (c) State the current when the voltage is increased to  $+2.0 \text{ V}$ .
- (d) Why does increasing the voltage have no effect on the current in the circuit?
- (e) The polarity is now reversed and the voltage increased until the current drops to  $0 \text{ A}$ . State the stopping voltage and hence the maximum energy of electrons emitted from the anode.
- (f) The light source is now made brighter without changing the frequency. Copy the figure and sketch a second curve that illustrates the effect of increasing the intensity of the blue light.
- (g) The light source is now returned to its original brightness and green light is used. A current is still detected. Sketch a third curve to illustrate the effect of using light of a lower frequency.
- (h) The apparatus is altered so that the anode consists of a metal with a smaller work function. Again blue light is used. Sketch a fourth curve to illustrate the effect of changing the anode without changing either the brightness or colour of the light.
9. The work function for a particular metal is  $3.8 \text{ eV}$ . When monochromatic light is shone onto the photocell, electrons with energy  $0.67 \text{ eV}$  are emitted.
- (a) What is the stopping voltage required to stop these electrons?
- (b) What is the frequency of the monochromatic light used?
- (c) What is the threshold frequency of the metallic surface?
10. In a photoelectric effect experiment, the threshold frequency is measured to be  $6.2 \times 10^{14} \text{ Hz}$ .
- (a) Calculate the work function of the metal surface used.
- (b) If electrons of maximum kinetic energy  $3.4 \times 10^{-19} \text{ J}$  are detected when light of a particular frequency is shone onto the apparatus, what is the stopping voltage?
- (c) With the same source of light, what is the wavelength and hence the momentum of the photons?

11. When light of frequency  $5.3 \times 10^{14}$  Hz is shone onto a metal surface, electrons with a maximum kinetic energy of 1.7 eV are emitted. A second photocell is now positioned and this time, using the same light, electrons of energy 1.3 eV are emitted. Calculate the difference between the work functions of the two photocells. Which cell has the greater work function: the first or the second?
12. One electron ejected from a clean zinc plate by ultraviolet light has a kinetic energy of  $4.0 \times 10^{-19}$  J.
- What would be the kinetic energy of this electron when it reached the anode, if a retarding voltage of 1.0 V was applied between the anode and cathode?
  - What is the minimum retarding voltage that would prevent this electron reaching the anode?
  - All electrons ejected from the zinc plate are prevented from reaching the anode by a retarding voltage of 4.3 V. What is the maximum kinetic energy of electrons ejected from the zinc?
  - Sketch a graph of photocurrent versus voltage for this metal surface. Use an arbitrary photocurrent scale.
13. The diagram below shows the energies of electrons in a block of copper. Zero energy is defined to be that for a stationary, free electron.

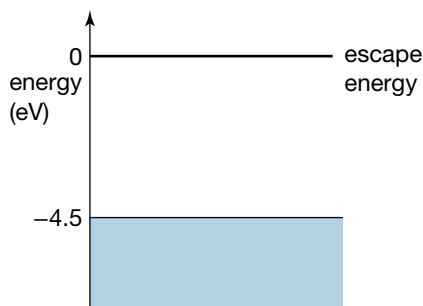

- What is the work function of copper?
- A stream of light whose photons have an energy of 5.9 eV shines on the copper surface. Describe the possible outcome for electrons in the copper having energies of:
  - 4.7 eV
  - 5.3 eV
  - 5.9 eV
  - 6.3 eV.

14. Robert Millikan performed his photoelectric experiment using a clean potassium surface, with a work function of 2.30 eV. He used a mercury discharge lamp. One wavelength of radiation emitted by the lamp was 254 nm, in the ultraviolet.
- What is the maximum kinetic energy of electrons ejected from the potassium surface by this UV radiation?
  - What voltage would be required to reduce the photocurrent in the cell to zero?
  - Sketch a graph of maximum electron kinetic energy versus frequency for potassium. Show the point on the graph obtained from the 254 nm UV radiation.
  - Repeat this sketch for sodium, which has a work function of 2.75 eV.
15. When the surface of a material in a photoelectric effect experiment is illuminated with light from a mercury discharge lamp, the stopping voltages given in the table are measured.

Wavelength (nm)	Stopping voltage (V)
366	1.48
405	1.15
436	0.93
492	0.62
546	0.36
579	0.24

Plot the stopping voltage versus the frequency of the light and use the graph to determine:

- the threshold frequency
  - the threshold wavelength
  - the work function of the material, in eV
  - the value of Planck's constant.
16. Give four reasons why a particle model for light better explains the observations made for the photoelectric effect. In particular, explain why a wave model is inadequate for each reason.

## REMEMBER

Before beginning this chapter, you should be able to:

- calculate the change in kinetic energy of a charged particle having passed through a voltage  $V$
- recall that the behaviour of electrons can be explained using a particle model
- use the equations  $c = f\lambda$ ,  $E = hf$  and  $p = \frac{h}{\lambda}$  for photons of light
- use the equations  $E = \frac{1}{2}mv^2$  and  $p = mv$  for objects with mass such as electrons
- recall the diffraction pattern associated with radiation, such as light, passing through a narrow single slit, in particular that for diffraction effects to be noticeable, the ratio  $\frac{\lambda}{w}$  must be large enough.

## KEY IDEAS

After completing this chapter, you should be able to:

- explain the production of atomic absorption and emission line spectra, including those from metal vapour lamps, in terms of energy transfer between photons and atomic electrons
- interpret spectra and calculate the energy of absorbed or emitted photons:  $E = hf$

- analyse the absorption of photons by atoms with reference to:
  - the change in energy levels of the atom due to electrons changing state
  - the frequency and wavelength of emitted photons:

$$E = hf = \frac{hc}{\lambda}$$

- describe the quantised states of the atom with reference to electrons forming standing waves, and explain this as evidence for the dual nature of matter
- compare the production of light in lasers, synchrotrons, LEDs and incandescent lights
- interpret electron diffraction patterns and emission spectra as evidence for the wave-like nature of matter
- distinguish between the diffraction patterns produced by photons and electrons
- calculate the de Broglie wavelength of matter:  $\lambda = \frac{h}{p} = \frac{h}{mv}$
- compare the momentum of photons and of matter of the same wavelength including calculations using  $p = \frac{h}{\lambda}$
- interpret the single photon/electron double-slit experiment as evidence for the dual nature of light and matter
- explain how diffraction from a single-slit experiment can be used to illustrate Heisenberg's uncertainty principle
- explain why classical laws of physics are not appropriate to model motion at very small scales.

Until the nineteenth century, most scientists thought that light was a type of wave, but later evidence pointed towards light behaving more like a stream of particles. In the twentieth century, physicists realised that neither description was sufficient for light. In this chapter we see that the same discovery was also made about the electron.



# The particle model of matter unhinged

As we look at the structure of matter keep the questions ‘How do we know?’ and ‘What is the evidence?’ in mind. We will consider the evidence for atoms and key experiments that determined the characteristics of one of the particles within each atom, the electron.

The idea that all matter was constructed from minute, indivisible particles — atoms — originated in Greece about 400 BC. The word *atomos* means ‘indivisible’ in Greek. Thinkers in these ancient times shared many of our understandings about atoms — that atoms exist in empty space, that they are in ceaseless motion and that changes we would call chemical changes occur when atoms change the ways they are combined.

Aristotle (389–321 BC) dismissed the possibility of the existence of empty space, and therefore atoms as well. Instead he supported the idea that matter was continuous. He developed a scheme in which matter was formed from mixtures of the elements earth, air, fire and water and envisaged that these elements could be transformed from one into another. Aristotle’s concept of matter became the accepted view. Like his ideas about motion, Aristotle’s views about matter were not strongly challenged for almost 2000 years. After Newtonian mechanics swept away Aristotelian views about mechanics, Aristotle’s views about matter also began to be questioned. People started thinking about atoms again.

In the eighteenth century, chemistry became a science of careful observation and measurement. Chemists performed all sorts of chemical reactions between solids, liquids and gases, heating compounds to break them into their separate components, combining materials to make new ones, weighing solids and measuring volumes of liquids and gases. The outcome was a huge array of information about the relative amounts of different substances that react together. By the early nineteenth century this collection of data had provided John Dalton, an English chemist, with the foundation for a new, revised atomic theory. He published his theory in two parts in 1808 and 1810. Its essential points were:

- All matter is made from atoms, and a pure element is made of identical atoms. A material is an element if it cannot be broken down further into components.
- There is a limited number of elements, and therefore a limited number of different atoms.
- Each compound is a mixture of elements and the smallest unit of a compound is a grouping of the atoms of those elements.
- Chemical reactions are simply rearrangements of atoms — atoms are never created or destroyed.

Individual atoms had not been isolated when Dalton proposed the atomic theory. Confidence in their existence was based on chemists’ success in modelling chemical reactions as rearrangements of atoms. Within a century there was convincing evidence that atoms themselves were divisible, that they were constructed from even more fundamental particles.

The next question naturally arises: if atoms themselves are divisible, what types of particles make up atoms? The journey towards the discovery of fundamental particles, the constituents of atoms, had begun. The first fundamental particle to be identified was the electron, in 1897; the proton was discovered in 1919 and the neutron in 1932. Along the way physicists also discovered cathode rays, beta particles, alpha particles and gamma rays, but they still lacked a consistent and integrated model for matter.



Chemical reactions are simply rearrangements of atoms.



To make the situation more confusing, electromagnetic radiation — light — had been extremely well modelled as a wave phenomenon, but evidence from the photoelectric effect and radiation emitted from hot objects (black body radiation) required a radical shift in thinking. What emerged was the necessity of a wave-particle model for light at a time when matter was considered only as a type of particle.

In this chapter we will concentrate on the discovery of the electron. The electron was at first thought to be a particle but was revealed to have, like light, a dual character. Sometimes it behaved as though it was a particle subject to Newton's laws of motion, and sometimes it behaved like a wave, demonstrating interference and diffraction effects. Furthermore, the observation of emission and absorption spectra of photons from and by atoms paved the way for interpreting the behaviour of electrons in atoms purely in terms of wave concepts. Models of electrons as particles orbiting the nucleus of an atom, based on Rutherford's planetary model, failed to account for the spectra observed; in fact, particle models led to the prediction that atoms could not exist as stable entities.

With the development of quantum mechanics in the 1920s, and in particular the Heisenberg uncertainty principle, a consistent though radical understanding of nature would emerge — one in which both wave and particle models could combine successfully under the cloak of uncertainty.

## The discovery of electrons

When an electric current passes through a gas at low pressure that is contained in a sealed glass tube, the walls of the tube give off an eerie green glow. The glass fluoresces. This was discovered shortly after the important 1855 invention of pumps that could evacuate tubes down to  $10^{-4}$  of atmospheric pressure.

Careful study of this effect did not happen immediately. It was not until 1875 that the English physicist William Crookes began his investigations. He quickly concluded that the glass fluoresced when rays emitted from the negative electrode, the cathode, struck it. The rays became known as cathode rays. Rays emitted by all cathode materials shared the same properties. A 20-year debate about whether the rays were electromagnetic *waves* or streams of charged *particles* was finally resolved in 1897. In that year, an English physicist Joseph John (J. J.) Thomson showed beyond doubt that the rays were streams of negatively charged particles. These are the particles we now call electrons.

Why did the debate drag on for so long? Surely it cannot be that hard to distinguish between charged particles and electromagnetic waves! The problem lay in the apparently inconsistent behaviour of the rays. They could pass through thin metal foils without damaging them — could charged particles do that? They were obviously deflected by magnetic fields — they must be charged particles then. The rays did *not* appear to be deflected by electric fields — again, they must be electromagnetic radiation. However, they travelled considerably more slowly than light . . . and so on. Thomson's ingenuity with experimental work solved the problem.

The most crucial barrier to the charged particle theory was the absence of deflection in electric fields. Thomson was able to show that this was due to the rays themselves. In Thomson's words:

*On repeating the experiment I first got the same result, but subsequent experiments showed that the absence of deflection is due to the conductivity conferred on the rarefied gas by the cathode rays. On measuring this conductivity . . . it was found to decrease very rapidly with the exhaustion of the gas . . . at very high exhaustions there might be a chance of detecting the deflection of cathode rays by an electrostatic force.*

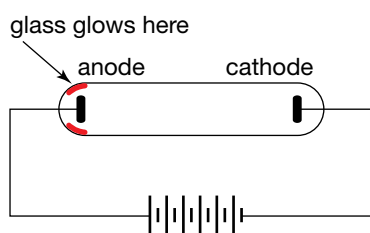

Production of cathode rays



Sir J. J. Thomson

So, the cathode rays ionised the gas in the tube. These ions were attracted to the plate having the opposite charge and the line-up of ions effectively neutralised the charge on the plate, allowing the cathode rays to pass by unaffected.

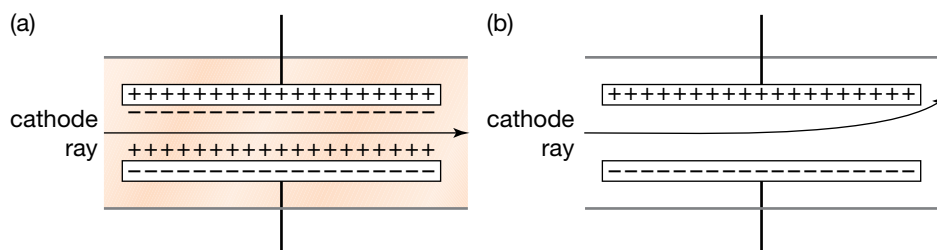

Cathode ray path (a) at high and (b) low gas pressure. At higher pressures a sheath of ionised gas shields the cathode rays from the effects of the applied electric field.

After evacuating the chamber Thomson saw deflection! He found that the particles were always deflected towards the positive plate, confirming that they were negatively charged particles. He then made clever use of the particles' deflection in both an electric field and a magnetic field to measure the charge-to-mass ratio of the particles in cathode rays.

No matter what gas was in the chamber, what cathode current was used, or what magnetic field was applied, Thomson measured the same value for the charge-to-mass ratio,  $q:m$ , of particles in the cathode rays. He concluded that these negative particles were elementary particles that were contained in all matter and called them corpuscles. An *elementary* particle is one that cannot be split into smaller particles, just as an *element* is a substance that cannot be broken down into other substances.

Electric effects can be produced in a range of ways. A light filament can be made to glow using electrochemical reactions in batteries, or an electrostatic generator such as a Van de Graaf generator, or by using electric generators that exploit the interactions between electricity and magnetism (as was investigated by Faraday). In each case the glowing filament is supplied with energy by electrons. As Thomson said in his Nobel Prize lecture:

*The corpuscle appears to form part of all kinds of matter under the most diverse conditions; it seems natural therefore to regard it as one of the bricks of which atoms are built up.*

Electrons were thought to be truly elementary particles.

We now know that electrons are part of a family of particles called leptons and that they have a mass of  $9.1 \times 10^{-31}$  kg and a negative charge of magnitude  $1.6 \times 10^{-19}$  C. We also know that they form the outer layers of atoms in shells and that they determine the chemical properties of different elements due to the way they are arranged around the nucleus.

One of the next steps in the journey towards a consistent picture of atomic structure and hence the nature of both light and matter was the observation of emission and absorption spectra. As discussed in the next section, the mechanics of emission and absorption spectra reveal that electrons in orbitals about the nucleus of an atom cannot be modelled as particles. Electrons in motion around the nucleus do not emit light as they would be expected to according to well-accepted models for accelerated charged particles; instead, they exist in a stationary state, as it is called using the language of quantum

mechanics, and only emit photons of specific frequencies when the atom undergoes a change in internal energy. The observation of this type of emission spectrum, which shows discrete lines rather than a continuous spectrum, leads to the conclusion that electrons must be modelled as a type of wave phenomenon. This means they must have an associated wavelength. As we shall see, just as Albert Einstein caused a stir with his interpretation of the photoelectric effect, Louis de Broglie would do likewise in 1923 when he asserted that matter had associated wavelengths. For this discovery de Broglie was awarded the Nobel Prize for Physics in 1929.

## Emission spectra — atoms emit photons

If you dip a loop of wire into a solution of common salt in water and then place the loop in the flame of a Bunsen burner, you will see that where the flame touches the loop it is transformed from blue into glorious gold. If you then placed two slits in a line to convert the light from the flame into a beam, and used a prism to disperse the light from the beam and a telescope to take a good look at the results, you would be following in the steps of the scientists who developed the field of spectroscopy. You would have constructed a **spectrometer** that could show you that spectra produced by solutions of sodium chloride and sodium carbonate both look like the spectrum shown in the figure opposite. Sodium atoms in the flame produce the spectrum, and it is identical to the spectrum observed when an electric current is passed through a container of sodium gas at low pressure. Spectrometers were used in the early 1860s to identify two new elements, rubidium and caesium, from unidentified colours in the spectrum of the vapour of a mineral water.

---

A **spectrometer** is a device used to disperse light into its spectrum.

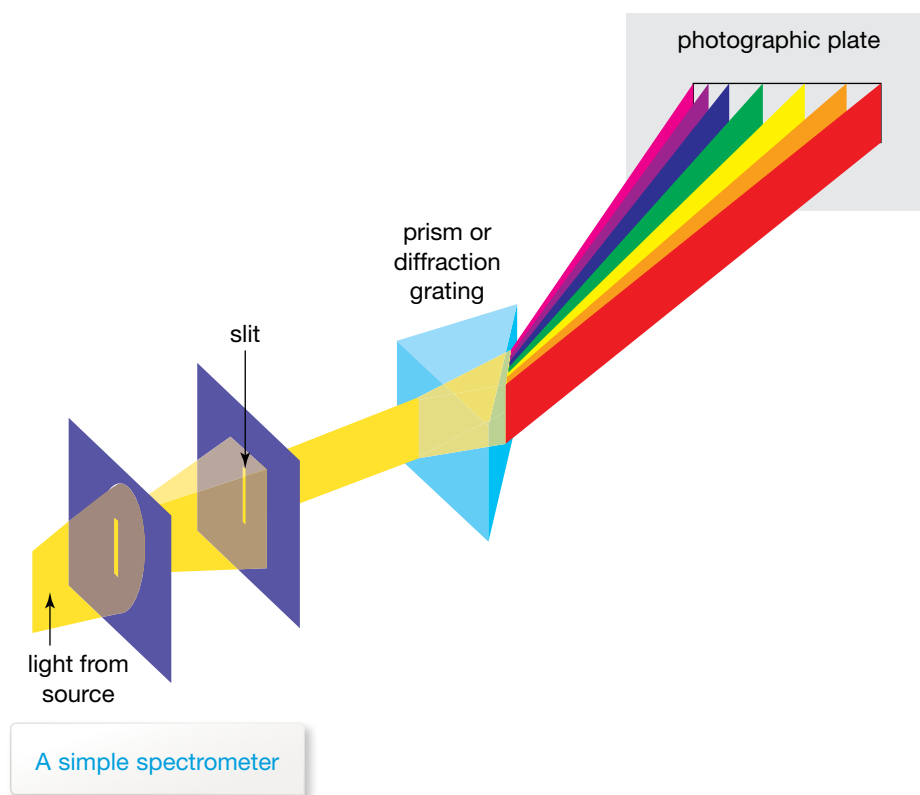



(a) Sodium vapour street light (whose spectrum is dominated by its yellow emission lines), (b) characteristic colour of sodium flame, (c) visible line spectrum of sodium atoms, and (d) visible line spectrum of hydrogen atoms



An **emission spectrum** is produced when light is emitted from an excited gas and passed through a spectrometer. It includes a series of bright lines on a dark background. The bright lines correspond to the frequencies of light emitted by the gas.

The colours in the spectrum produced by atoms in this way have become known as spectral lines because of the sharp lines they produce on the photographic plate in a spectrometer. These photographs are known as **emission spectra**.

The fact that the spectrum of an element is its 'fingerprint' makes it possible to detect tiny traces of elements in complex mixtures, and for astronomers to use the light emitted by remote stars to identify elements in the stars. Of more interest to us here is the contribution line spectra make to developing our understanding of both the structure of matter and the behaviour of light. The key is the sharp line nature of the spectra. Sharp lines have precise wavelengths, and in the photon model for light this indicates precise photon energies. So line spectra tell us that a particular type of atom emits light energy in quite specific fixed amounts. This behaviour is remarkably different to that of a hot filament and other incandescent light sources, which emit a continuous spectrum of light with a range of wavelengths.

Any model of atomic structure must be able to explain the behaviour of the atom leading to discrete emission spectra. In 1911 Ernest Rutherford, an eminent New Zealander who directed the Cavendish laboratory at Cambridge, established that electrons revolved around a nucleus, with most of the atom being empty space. Then in 1913 Niels Bohr, a Danish physicist, proposed what was then a revolutionary model for the behaviour of these atoms and electrons. It provided the basis for our current understanding of atoms. The hydrogen atom — the simplest, with just a single electron revolving around a proton — was the initial testing ground for Bohr's model. The discussion which follows focuses on the hydrogen atom.

Bohr's model had two main ideas.

1. Each atom has a number of possible stable states, each state having its own characteristic energy. In each atomic state the electron is in a stable orbit around the nucleus. It obeys Newton's laws of mechanics but does not

### study on

Unit 4

**Emission spectra**

AOS 2

Summary screen and practice questions

Topic 3

Concept 1

**Quantised** describes quantities that cannot be divided or broken up into smaller parts.

radiate electromagnetic waves as predicted by Faraday. (This idea of Bohr's was radical. Electromagnetic theory predicted that an orbiting electron, since accelerating would radiate electromagnetic radiation continuously, losing energy and spiralling into the nucleus.) The energy of these states may be imagined as the rungs on a ladder. The energy of the atom must lie exactly on a rung of the ladder, and never between. We say that the energy levels are discrete, or **quantised**. The energy ladder diagram for hydrogen is shown below.

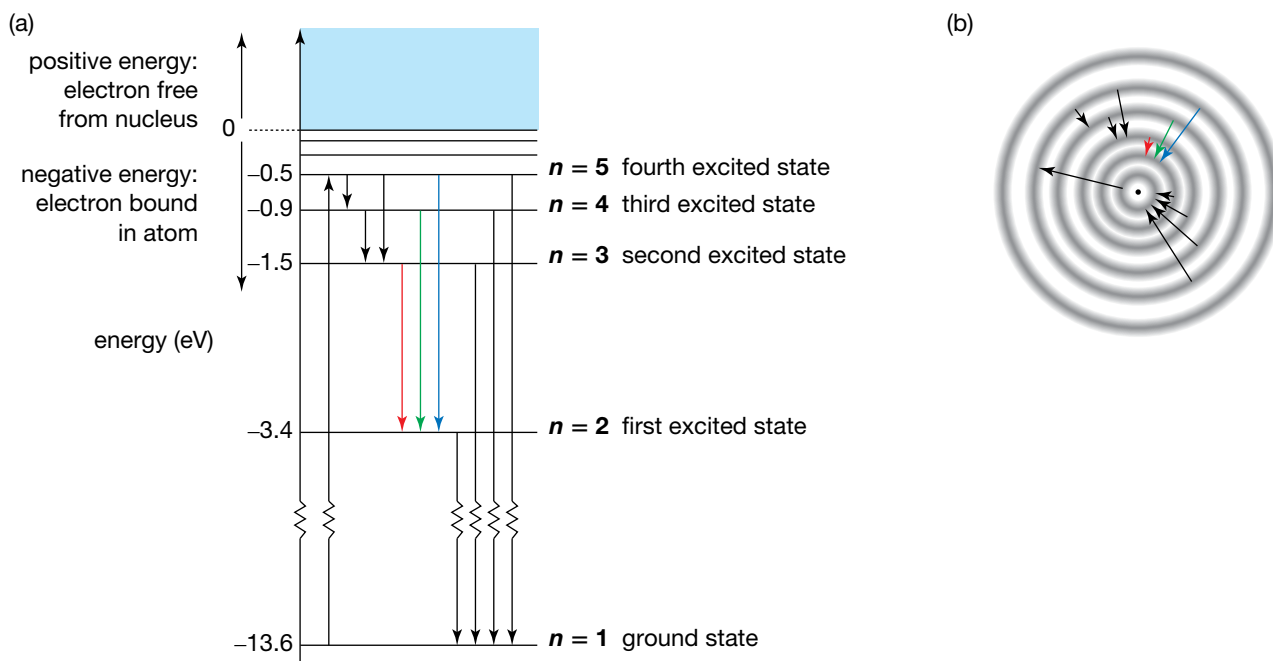

(a) Atomic energy level view of the spectral series of hydrogen (visible colours are shown as coloured arrows), and (b) electron orbit view of the spectral series of hydrogen as illustrated in (a). These lines are seen in the spectrum in figure (d) on page 294.

**study on**

Unit 4 **Quantised energy level model of the atom (1)**  
AOS 2  
Topic 3

Concept 3 Summary screen and practice questions

2. An atom can jump up or down from one state to another, corresponding to the transfer of the electron from one orbit to another. When the atom drops to a state having a lower energy, a photon is emitted whose energy is equal to the energy loss of the atom. Alternatively, an atom may absorb a photon, raising the energy of the atom in the process. The energy of the photon must exactly match an energy difference between the current state of the atom and one of the higher energy states it is allowed to jump to. Emission and absorption of photons are illustrated in the figure below.

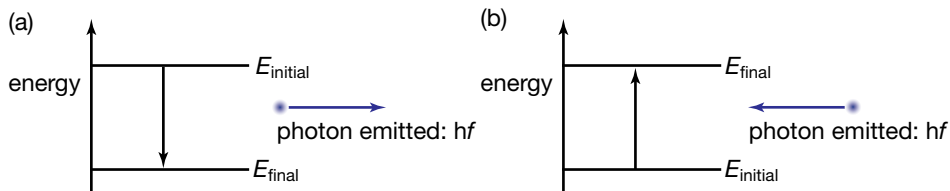

(a) Emission of light:  $E_{\text{photon}} = hf = \Delta E = E_{\text{initial}} - E_{\text{final}}$   
(b) Absorption of light:  $E_{\text{photon}} = hf = \Delta E = E_{\text{final}} - E_{\text{initial}}$

**study on**

Unit 4 **Quantised energy level model of the atom (2)**  
AOS 2  
Topic 3

Concept 4 Summary screen and practice questions

Atoms can gain energy in other ways. Absorption of energy can occur during a collision of an atom with an electron, the process operating in a discharge tube, or a collision with an ion (as occurs in a flame).

The **ground state** is the state of an electron in which it has the least possible amount of energy.

An **excited state** is a state in which an electron has more energy than its ground state.

### study on

Unit 4

AOS 2

Topic 3

Concept 4

Do more

Hydrogen  
emission spectra



States of the atom are commonly labelled using the terms **ground state** for the lowest energy state, followed by the **excited states** at higher energy, often labelled first excited state, second excited state, and so on. The most common choice for the zero of energy is the energy of an electron and proton that are completely free from one another — that is, stationary, at an infinite separation. Using this scale, the energy of an electron bound to a proton in a hydrogen atom is negative. The system of a stationary proton and a separated, freely moving electron has a positive energy that is equal to the kinetic energy of the electron.

Let us examine how this explains the emission spectrum of hydrogen. Most hydrogen atoms at room temperature are in the ground state. In flames or discharge tubes, atoms are raised to excited states by collisions with other particles. For example, in the figure at the bottom of page 295, the atom has first been excited into its fourth excited state where it has an energy of  $-0.5$  eV. This is indicated by the upward arrow on the left-hand side of the diagram. Cascading transitions to the ground state are then possible, with a photon emitted during each transition. These are indicated by the downwards arrows. This model of atomic structure neatly accounted for emission spectra.

### Sample problem 12.1

Consider an energy level diagram for a fictitious atom shown below.

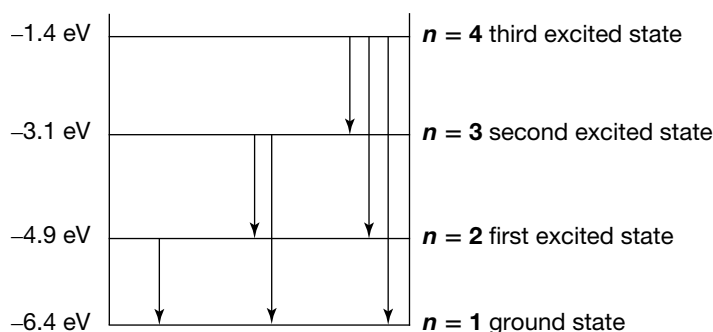

Consider a large population of atoms all excited to the third excited state ( $n = 4$ ), from which an emission spectra is able to be obtained resulting in all atoms decaying the ground state. Calculate all 6 possible energies in electron volts for photons emitted by the large population of atoms, and arrange them in ascending order.

**Solution:** There are 6 possible transitions: 3rd excited state to ground state, 3rd to 1st, 3rd to 2nd, 2nd to ground state, 2nd to 1st, and finally 1st to ground state. The energy of the emitted photon is calculated by finding the difference between the energies of the states for each transition. For the  $n = 4$  to  $n = 1$  transition:

$$\begin{aligned} E_{\text{photon}} &= E_{\text{initial}} - E_{\text{final}} \\ &= -1.4 \text{ eV} - (-6.4 \text{ eV}) \\ &= 5.0 \text{ eV.} \end{aligned}$$

This gives the highest energy of any photons emitted by this atom when in the 3rd excited state. The remaining five calculations give energies of 3.5 eV (3rd to 1st), 1.7 eV (3rd to 2nd), 3.3 eV (2nd to ground state), 1.8 eV (2nd to 1st) and finally 1.5 eV (1st to ground state).

Arranged in ascending order, the 6 photon energies are 1.5 eV, 1.7 eV, 1.8 eV, 3.3 eV, 3.5 eV and 5.0 eV.

By collecting an emission spectrum containing many discrete spectral lines and establishing the photon energy associated with each line, it is possible to work backwards to construct an energy level diagram for an atom.

### Revision question 12.1

Consider an energy level diagram for a fictitious atom shown below.

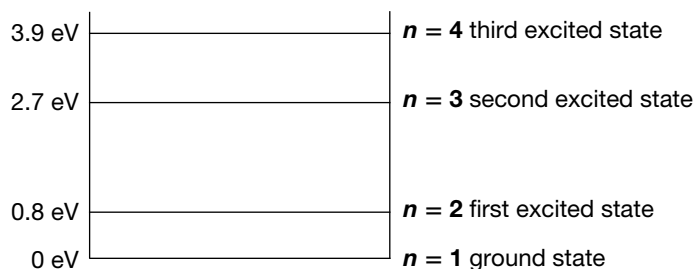

- Calculate the highest energy and hence the frequency of a photon emitted by this atom in the  $n = 4$  state.
- Calculate the lowest energy and hence the frequency of a photon emitted by this atom in the  $n = 3$  state.

### Sample problem 12.2

What is the shortest wavelength of light emitted by hydrogen atoms that were initially excited into the third excited state? The energies of states of the hydrogen atom are found in table 12.1.

**Solution:** Light of the shortest wavelength is emitted when the photons have the greatest energy (when the atoms experience the greatest possible energy change). This will be the transition to the ground state.

For  $n = 4$  to  $n = 1$  transition:

$$\begin{aligned}
 E_{\text{photon}} &= E_{\text{initial}} - E_{\text{final}} \\
 &= (-0.85 \text{ eV}) - (-13.61 \text{ eV}) \\
 &= 12.76 \text{ eV} \\
 &= 12.76 \text{ eV} \times 1.6021 \times 10^{-19} \text{ J eV}^{-1} \\
 &= 2.0 \times 10^{-18} \text{ J} \quad (\text{calculator says } 2.04428 \times 10^{-18} \text{ J})
 \end{aligned}$$

$$\begin{aligned}
 \lambda_{\text{photon}} &= \frac{hc}{E_{\text{photon}}} \\
 &= \frac{6.6262 \times 10^{-34} \text{ J s} \times 2.9979 \times 10^8 \text{ m s}^{-1}}{2.04428 \times 10^{-18}} \\
 &= 9.7 \times 10^{-8} \text{ m}.
 \end{aligned}$$

This is ultraviolet radiation.

TABLE 12.1

H atom state	Energy (eV)
Third excited state $n = 4$	-0.85
Second excited state $n = 3$	-1.51
First excited state $n = 2$	-3.40
Ground state $n = 1$	-13.61

### Revision question 12.2

What is the lowest frequency and hence longest wavelength light emitted by hydrogen atoms that were initially excited to the third excited state? The energies of the states of the hydrogen atom are found in table 12.1.

An **absorption spectrum** is a spectrum produced when light passes through a cool gas. It includes a series of dark lines that correspond to the frequencies of light absorbed by the gas.

A **continuous spectrum** is a spectrum that has no gaps. There are no frequencies or wavelengths missing from the spectrum.

### study on

Unit 4 **Absorption spectra**

AOS 2 Summary screen and practice questions

Topic 3

Concept 2

### study on

Unit 4 

AOS 2 **See more**  
The production of atomic spectra

Topic 3

Concept 2

### study on

Unit 4 **Absorption spectra explained**

AOS 2 Summary screen and practice questions

Topic 3

Concept 5

### study on

Unit 4 **Emission spectra explained**

AOS 2 Summary screen and practice questions

Topic 3

Concept 6

## Absorption spectra — atoms absorb photons

Atoms also absorb light. They absorb those particular wavelengths that they would emit if the gas were excited. These are the frequencies that correspond to the differences in energy between the energy levels in the atoms. An **absorption spectrum** is a continuous spectrum with a series of dark lines indicating missing frequencies. Absorption spectra are produced by placing a sample of a gas in front of a **continuous spectrum** source, as shown in the figure below.

The atoms making up the gas absorb particular wavelengths, raising electrons within the atoms into excited states. The electrons drop back to the ground state emitting photons, but now in all directions. This means that the original beam of light has very little of those absorbed colours. The continuous spectrum has dark bands. Generally, the dark bands in an absorption spectrum correspond to the bright lines in an emission spectrum of the same gas if it were hot.

absorption spectrum

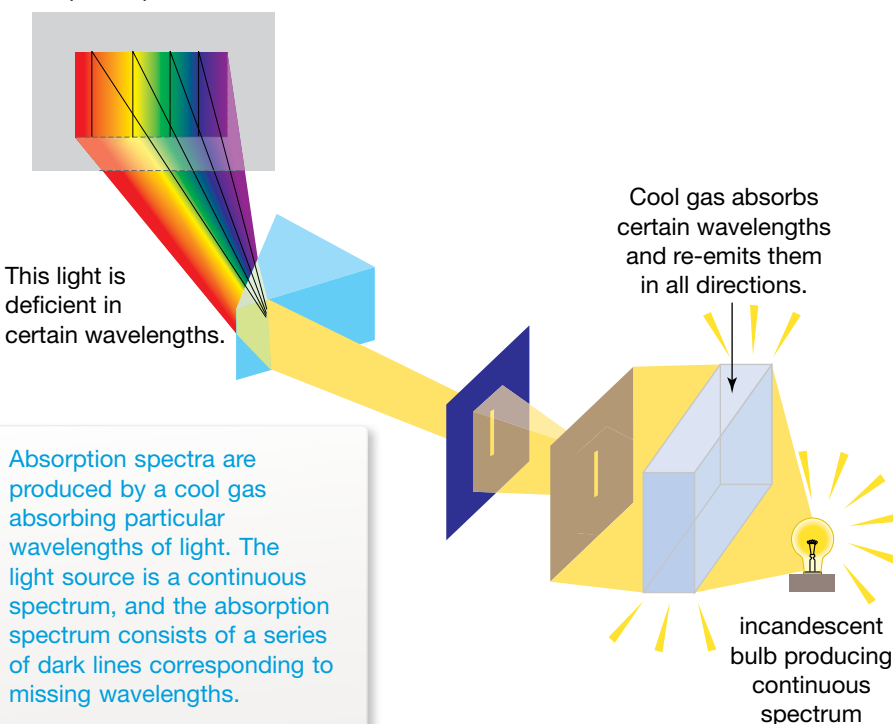

## Comparing emission and absorption spectra

As they rely on the same energy level structure, the emission and absorption spectra often appear to be negatives of one another. However, there are differences.

The emission spectrum usually includes lines missing from the absorption spectrum of the same element. For example, the emission spectrum of the hydrogen atom includes lines for transitions to all states of the atom. The absorption spectrum of hydrogen atoms at room temperature, however, contains lines in the ultraviolet region only, each line linked to a transition beginning at the ground state. This is because virtually all atoms are in the ground state at room temperature, to begin with — only  $\frac{1}{10^{17}}$  are not! The spectrum



## study on

Unit 4

AOS 2

Topic 3

Concept 6

**Do more**  
Photon emission  
by atoms



(a) Part of the emission spectrum for hydrogen. Only the region of the spectrum in which transitions to the ground state appear is shown. (b) The absorption spectrum for hydrogen. The transfer of photon energy to eject an electron is labelled 'ionisation'. All wavelengths less than the limiting value (that is, photons with energy greater than the limiting value) can be absorbed.

## eBookplus

### Digital doc

Investigation 12.1

Spectroscopes

doc-18556

of hydrogen in the Sun is a different story. The surface temperature of 6000 K is hot enough for the proportion of atoms in the first excited state to rise to  $\frac{1}{10^8}$ . Not large, but enough for their absorption spectrum to be detected.

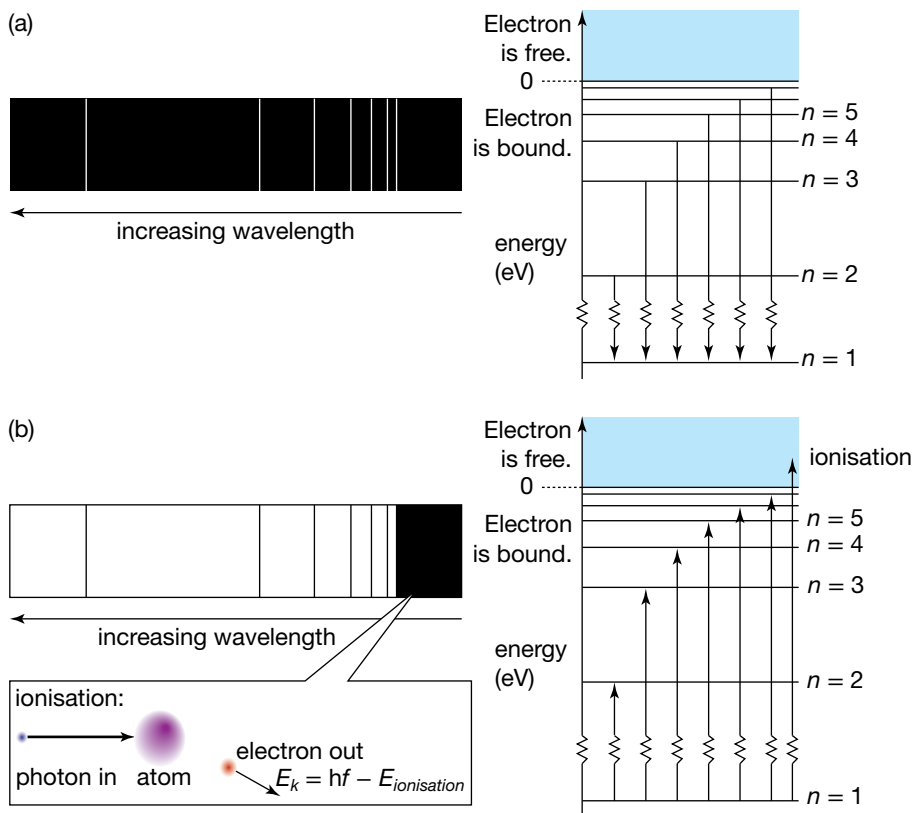

Series of lines in an absorption spectrum converge on a particular wavelength. This wavelength corresponds to the photon energy equal to the ionisation energy of the electron. All light with shorter wavelengths than this limit, and therefore greater photon energy, can be absorbed, removing the electron from the atom completely. As there is no restriction on the energy of a free electron, all photons having energy above the ionisation energy can be absorbed so all light with wavelengths below the limit may be absorbed. This is another example of the photoelectric effect where a minimum photon energy must be reached before electrons will be ejected.

## AS A MATTER OF FACT

A hydrogen electron in a stable or stationary state does not move in a circular, or even an elliptical, orbit around the proton — its distance from the proton changes continuously.

In fact the words 'circular', 'elliptical' and 'distance' become inappropriate when we consider an electron not as a particle but as some type of wave phenomenon. To understand and account for emission and absorption spectra, it is better if we think of an electron as having no specific location or path; instead, there is only a probability of locating it at various positions. This unpredictability is ultimately related to Heisenberg's uncertainty principle, which asserts that it is not possible to precisely measure both the location and the motion of any object at the same time. This realisation is the cornerstone of contemporary physics and the foundation of quantum mechanics.

(continued)

The most probable distance from proton to electron is  $5.29 \times 10^{-11}$  m, corresponding to the peak in the probability density curve.

It is called the Bohr radius and often quoted as the 'radius' of the hydrogen atom. It can be useful to think of the hydrogen atom as having a spherical cloud of negative charge surrounding the proton, representing the unpredictable motion of the electron. The diminishing density of the cloud at large distances from the proton indicates that the electron is less likely to be there.

While the proton–electron distance is not fixed or predictable for a particular state of the atom, the total energy of the atom is predictable. As the electron weaves its intricate path around the proton its kinetic energy changes, being greater when the electron is closer to the nucleus. However, the total energy *does not* change. There is a transformation between the kinetic energy and electric potential energy. Electric potential energy increases as kinetic energy decreases, and vice versa, keeping the total energy constant.

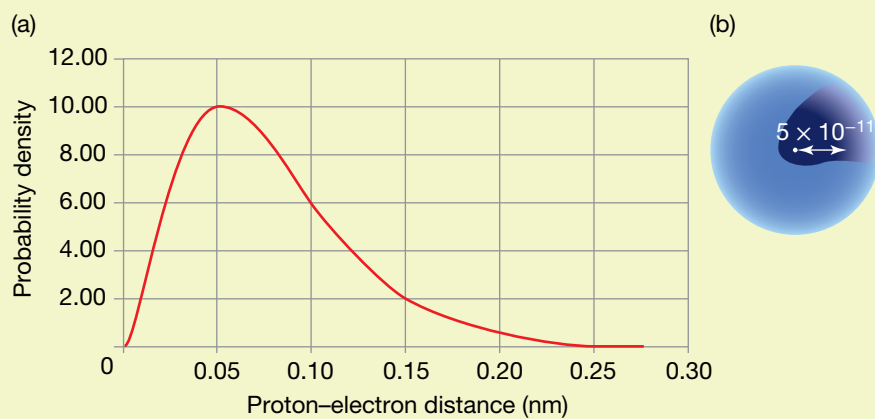

(a) The probability of finding an electron a certain distance from the nucleus, and (b) the cloud picture of a hydrogen atom.

## AS A MATTER OF FACT

Fluorescent lights are more efficient in transforming electrical energy into light than incandescent light globes, but that is not the only difference between them. Hot solids produce continuous, rainbow-like spectra but the spectra produced by discharge tubes are simply a few lines of pure colour. The ways they produce photons are quite different too.

### Hot filaments

Electrons passing through the hot metal filament of a light globe collide with ions in the lattice of the metal. In these collisions energy is transferred to the ions, causing them to oscillate about their positions in the lattice more vigorously. Between collisions, the electrons accelerate due to the electric field, accumulating energy for transfer in the next collision. The oscillating ions emit electromagnetic radiation, across the spectrum of wavelengths, producing the familiar visible light and infra-red and ultraviolet radiation.

### Fluoro tubes

Electrons in fluorescent lights are also accelerated by a potential difference, but they pass through a gas. They are often called discharge tubes, producing light by an electrical discharge through the gas. In most fluorescent tubes the gas is mercury vapour.

When an electron collides with an atom in the mercury gas it may transfer energy to the atom, raising the atom to a higher energy level. After a short time, about  $10^{-8}$  s, the atom drops to a lower energy level while emitting a single photon that takes with it the energy lost by the atom. The gas produces the mercury emission spectrum, with strong lines in the ultraviolet as well as the visible lines at 405 nm, 436 nm, 546 nm and 615 nm. The 405 nm and 436 nm lines have a higher intensity than the other lines, so the light from a mercury discharge tube appears bluish.

## Why is the light white?

Paint coats the inside of a fluorescent light tube. When UV photons emitted by the mercury atoms collide with the paint they may be absorbed, exciting the atoms in the paint to higher energy levels. The atoms then go through a series of transitions to lower energy levels, sometimes transferring their excess

energy to other particles in collisions but most frequently by emitting a photon. The energies of the emitted photons are less than the UV photon originally absorbed by the atom. The photon energies cover a wide range and approximate a continuous spectrum in some regions of the spectrum, making the light appear white.

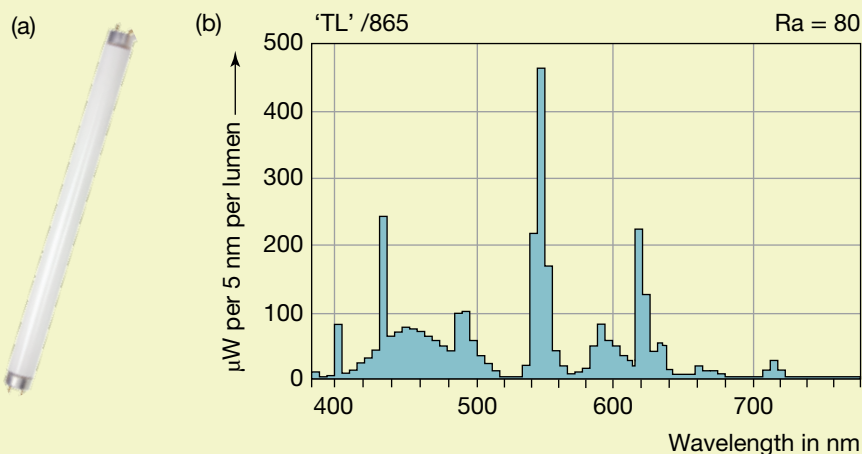

(a) A fluorescent light tube and (b) its spectrum. Note that the spectrum has a histogram appearance because the intensity is plotted for each 5 nm interval.

## PHYSICS IN FOCUS

### The laser

The word *laser* is an acronym of 'light amplification by stimulated emission of radiation.'

Lasers produce light in a fascinating way. Ordinary photon emission is called spontaneous emission, but the atoms in a laser undergo stimulated emission. When atoms and ions that are already in excited states encounter a photon that matches their excitation energy, they sometimes respond by dropping to the lower energy level, emitting a photon that is identical to the first photon, in energy, phase and direction. This process is called stimulated emission. As you might imagine, these two photons could stimulate the emission of two more photons, resulting in four identical photons, then, eight, sixteen and so on — like a nuclear chain reaction.

For the process to work, there must be a greater number of atoms in the upper state than in the lower state. Often a lamp is needed to *pump* the laser, providing photons to excite the atoms or ions into the upper energy level ready for stimulated emission. To increase the probability of a photon stimulating another photon emission, the laser cavity that contains the gas has mirrors on both ends, reflecting photons back and forth through the lasing material many times. The mirror at one end of the cavity is only partially reflecting. The photons passing through it form the laser beam. The distance between the mirrors is a whole number of half-wavelengths, so a standing wave is set up between them.

The colour of laser light is determined by the energy level structure of the atoms, or, for some lasers, the ions, which emit its characteristic photons.

(continued)

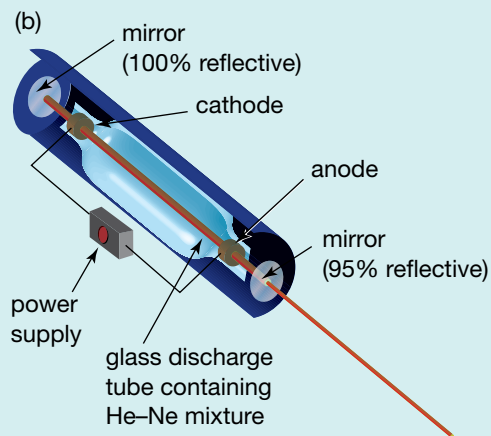

(a) The bright, intense light of a laser (left), and (b) operation of a laser (above)

The warning signs make it clear — lasers are dangerous. Do not look into the laser while it is on! Even though the power rating on a helium-neon laser found in a school laboratory is typically 1 mW compared to the 75 W of a conventional light bulb, the laser converts that energy into light much more efficiently. A laser also concentrates the photons it produces into a much smaller area, delivering a much greater intensity. Light emitted from a laser is said to be coherent because all the photons emitted are in phase. This coherence leads to particularly intense light due to constructive interference between in-phase photons.

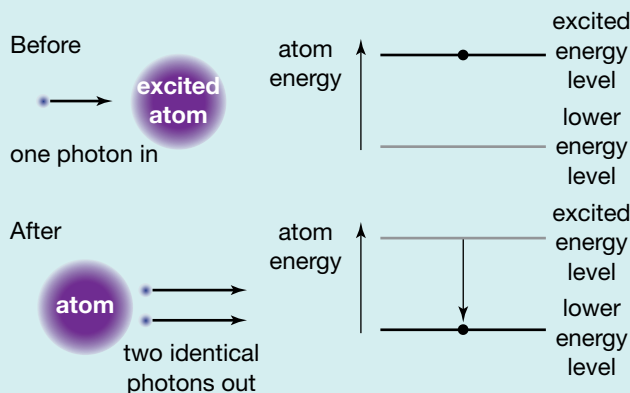

Stimulated emission produces identical photons.

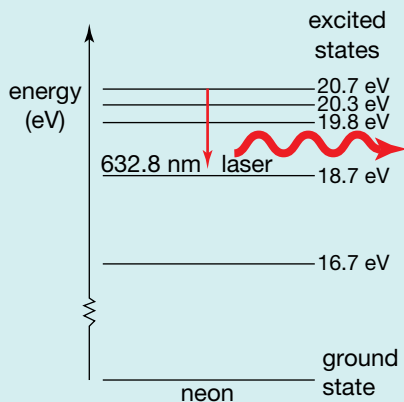

The energy ladder for neon atoms in a helium-neon laser, showing the lasing transition

## Making light

Visible light is one part of the electromagnetic spectrum (see the figure below).

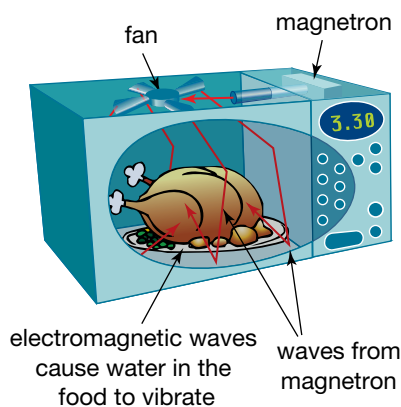

The magnetron of a microwave oven generates electromagnetic waves at the resonant frequency of water molecules. This makes the molecules vibrate faster and increases the temperature of the food.

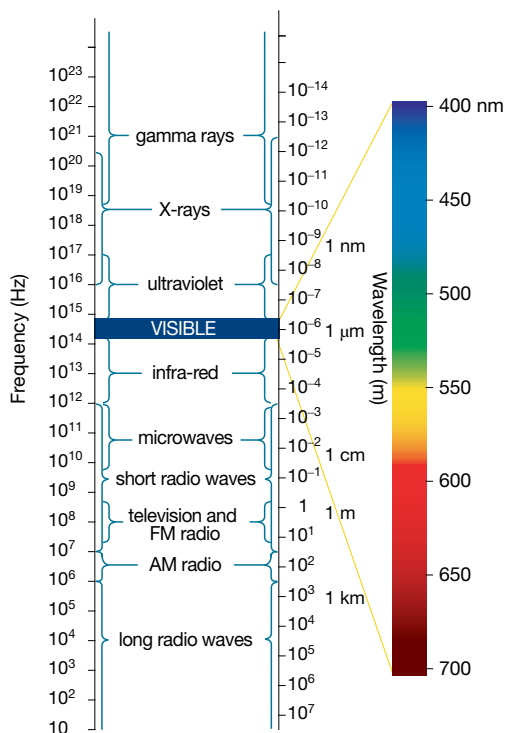

The electromagnetic spectrum

## Accelerating charged particles

Accelerating charged particles emit electromagnetic radiation. Radio and television transmitters are examples of this. They generate radio waves by driving a high-frequency electric current up and down an aerial. X-rays are generated when fast-moving electrons decelerate on striking a target — for example, in an X-ray machine or in a CRT television screen. A high-frequency oscillator generates microwaves by rapidly reversing the direction of an electric current — for example, in the magnetron of a microwave oven.

## Thermal radiation

Thermal radiation is the range of radiation given off by an object due to its temperature. It is due to the thermal movement of the atoms and to collisions between the outer-shell electrons of adjacent atoms.

Whenever a force is applied to an electron, it will accelerate and emit a photon. Collisions between atoms can cause the outer-shell electrons to accelerate and thus emit photons. This is known as thermal radiation. The spectrum of thermal radiation depends on the distribution of speeds of the atoms in the material.

If a material is opaque (cannot be seen through) it radiates a continuous spectrum. This spectrum has a peak value at a wavelength that depends on the temperature of the material. As the temperature increases, the wavelength emitting the greatest number of photons decreases. The figure below shows how the intensity of radiation is distributed over a range of wavelengths for an ideal **black body** at different temperatures. Note that the overall intensity

A **black body** is an ideal absorber of energy. It absorbs all electromagnetic radiation that falls on it and does not reflect any.

A **thermal spectrum** is the spectrum produced by a body due to its temperature.

A **line emission spectrum** shows the discrete frequencies or wavelengths produced by an excited material.

increases as the temperature increases, and that the wavelength with the peak intensity decreases as the temperature increases. The **thermal spectrum** of a black body is continuous. This is different to the **line emission spectrum** for individual atoms.

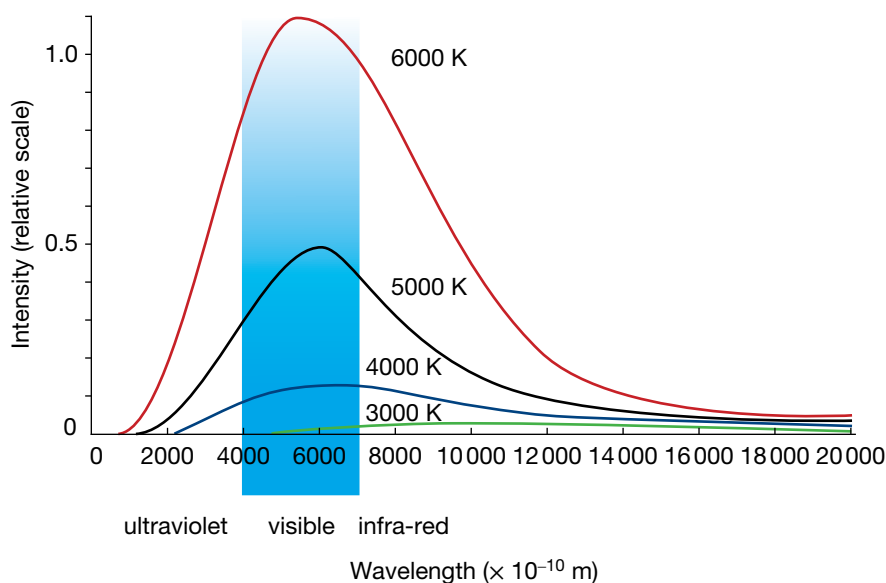

Thermal radiation for an ideal black body

## Incandescent light sources

Incandescent light sources emit light because of their temperature. They are thermal sources. Stars, candles and light bulbs with filaments are all incandescent light sources.

As an iron rod is heated in a furnace its temperature increases. At first it emits radiation only in the infra-red part of the electromagnetic spectrum. As it gets hotter, it starts to emit red light. It continues to heat up and emits more light in the visible region of the spectrum until it becomes white hot.

The colour of gases in a flame indicates the temperature of the flame. The blue part of a Bunsen burner flame is the hottest. Blue light has a shorter wavelength and more energy than red light. The light emitted by a candle is caused by the thermal motion of the atoms and molecules in the gases of the flame.

Incandescent light bulbs emit light by using an electric current to heat a tungsten filament. Tungsten is used because it is a metal and has a high melting point. The range of colours of light emitted depends on the temperature of the filament. The atoms in the filament vibrate violently when an electric current passes through it. Collisions between outer-shell electrons produce the light. Incandescent light bulbs are filled with an inert gas so that the metal in the filament will not be able to take part in chemical reactions and disintegrate. The filament reaches temperatures greater than  $2600^{\circ}\text{C}$ .

## Fluorescent light sources

Fluorescence occurs when an atom is excited from one energy state to another by the absorption of a photon — it might return to the ground state by making two or more jumps. This can occur only if there are two or more allowable energy states in between. At each jump, the atom may emit photons with a smaller energy and frequency than the absorbed photon. This process is known as fluorescence.

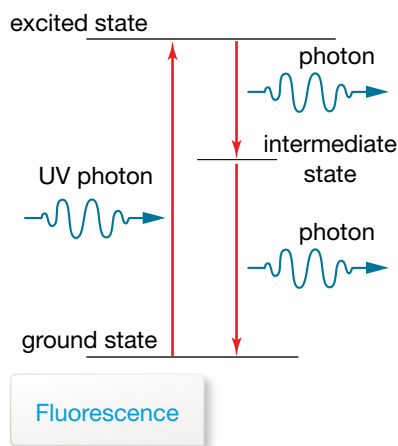

There are many non-incandescent light sources that are used for indoor and outdoor lighting. Most of these produce visible light when an electrical current passes through a gas at a very low pressure. The gas is contained in a glass tube with electrodes at each end. The atoms or ions of the gas become excited when they collide with electrons emitted by the electrodes. This means that electrons in the atoms or ions are sent into a high energy level. When they fall to lower states they emit photons of light. Some of these photons are in the visible part of the electromagnetic spectrum. This process produces a line emission spectrum that is unique for each gas.

Examples of the gases used in discharge tubes include the noble gases (neon, argon and xenon) and metal gases such as sodium (used in streetlights) and mercury (found in household fluorescent tubes). Each gas produces characteristic colours that are determined by the colours present in the line spectra. That is why sodium streetlights are yellow and neon lights are red. Mercury gas discharge tubes mainly emit ultraviolet light.

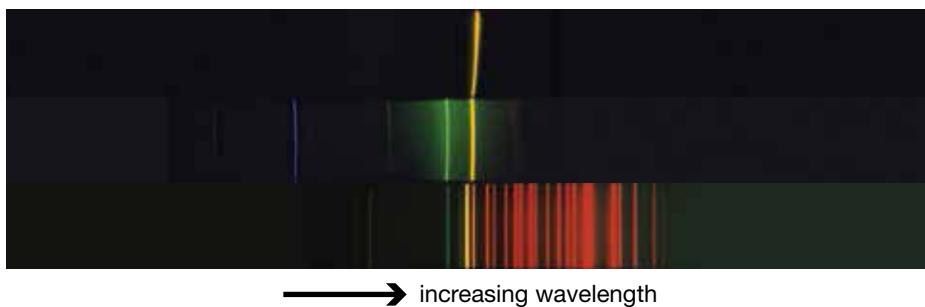

Gases excited by electrical discharge produce line emission spectra such as these for sodium, neon and mercury.

Household fluorescent light tubes are filled with mercury vapour and argon gas at a low pressure. The tubes are coated on the inside with phosphor particles. Phosphor particles absorb ultraviolet light and later re-radiate the energy as visible light by the process of fluorescence. You may have noticed that fluorescent lights keep glowing for several minutes after they are switched off. Fluorescent lights use less electrical power to produce the same amount of illumination as incandescent light bulbs. They, therefore, cost less to run. Energy efficient lights are usually thin fluorescent light tubes bent into a compact shape and mounted so they can be fitted to the light sockets used for incandescent globes.

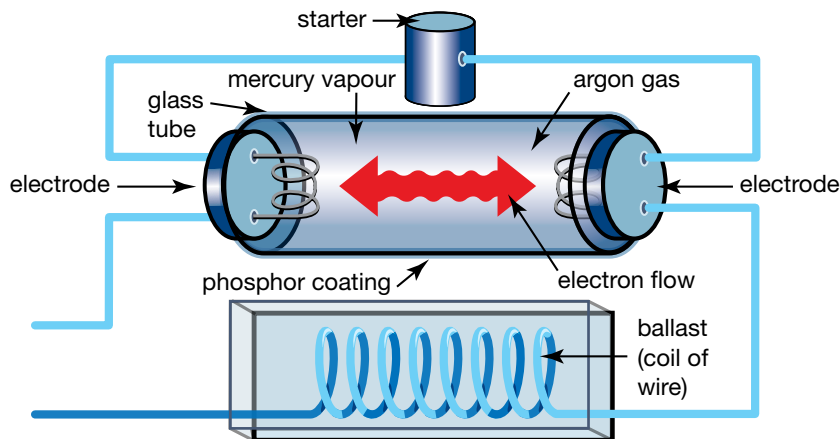

A household fluorescent light tube

The following figure shows the spectra from some common light sources. The Sun and a tungsten filament lamp have the continuous spectrum of thermal emitters, whereas a mercury vapour lamp has the line spectrum of a fluorescent light source.

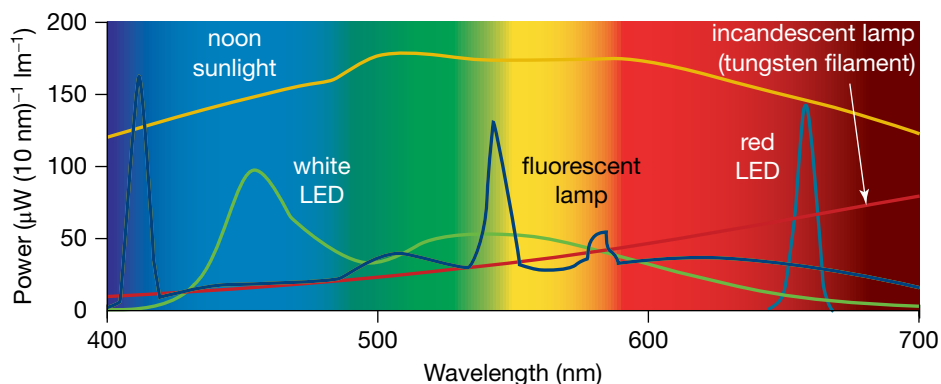

Spectra from some common sources of visible light

A **light-emitting diode (LED)** is a small semiconductor diode that emits light when a current passes through it.

A **p-n junction** is the border region between p-type and n-type materials that have been fused together.

A **semiconductor** is a material that has a resistivity between that of conductors and insulators.

## Light-emitting diodes

You should recall from Year 11 that a **light-emitting diode (LED)** is a small semiconductor diode that emits light from its **p-n junction** when it is forward biased and a current passes through it. **Semiconductors** are materials whose properties are midway between those of a good conductor and a good insulator. LEDs are used as light sources in optical-fibre systems. They can be made to emit any colour (red, green and yellow are the most common) by the choice of impurities added to the base semiconductor used in their construction. They can turn on and off rapidly, making them suitable for transmitting digital signals.

## Synchrotron radiation

Synchrotron storage rings are designed to produce synchrotron radiation, the electromagnetic radiation emitted when charged particles are accelerated.

### Characteristics of synchrotron radiation

Synchrotron radiation is emitted as photons that form a narrow cone as they head towards the target. The main characteristics of synchrotron radiation are:

- **Spectrum.** Synchrotron radiation is mostly in the form of X-rays, as they are the most useful. However, radiation across the electromagnetic spectrum, from infra-red upwards, can be produced. The spectrum is also continuous, which means there are no gaps or missing frequencies. Any frequency can be found in the range.
- **Brightness.** The intensity of the beam is hundreds of thousands times greater than that of conventional X-ray tubes. Brightness can be understood as the number of photons every second. It is more properly measured as the number of photons emitted per second per square millimetre of source size, per square milliradian of cone angle within a specific frequency range. Brightness can be as high as  $10^{19}$  photon  $s^{-1}$   $mm^{-2}$   $mrad^{-2}$ .
- **Divergence.** The beam of radiation spreads out like a cone as it travels down the beamline. Typically a beam cone would have a cone angle of a few microradians — that is, less than half of one thousandth of a degree.

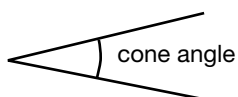
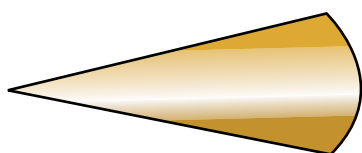

Cone of radiation showing cone angle. The size of the cone angle is a few microradians, which is less than half of one thousandth of a degree.



- *Polarisation.* The radiation from a synchrotron is polarised.
- *Duration.* Synchrotron radiation comes in pulses, typically lasting about one billionth of a second.

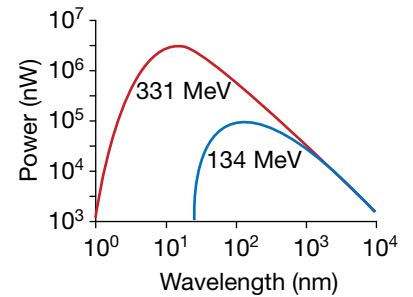
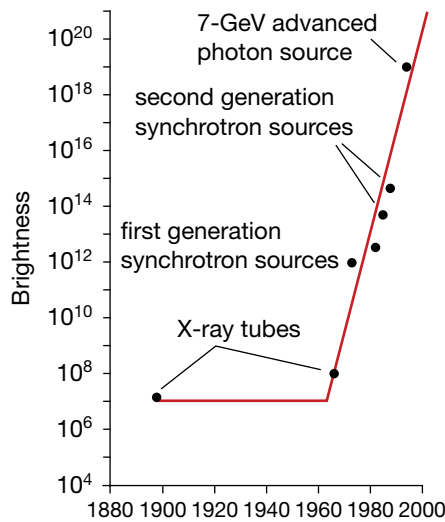
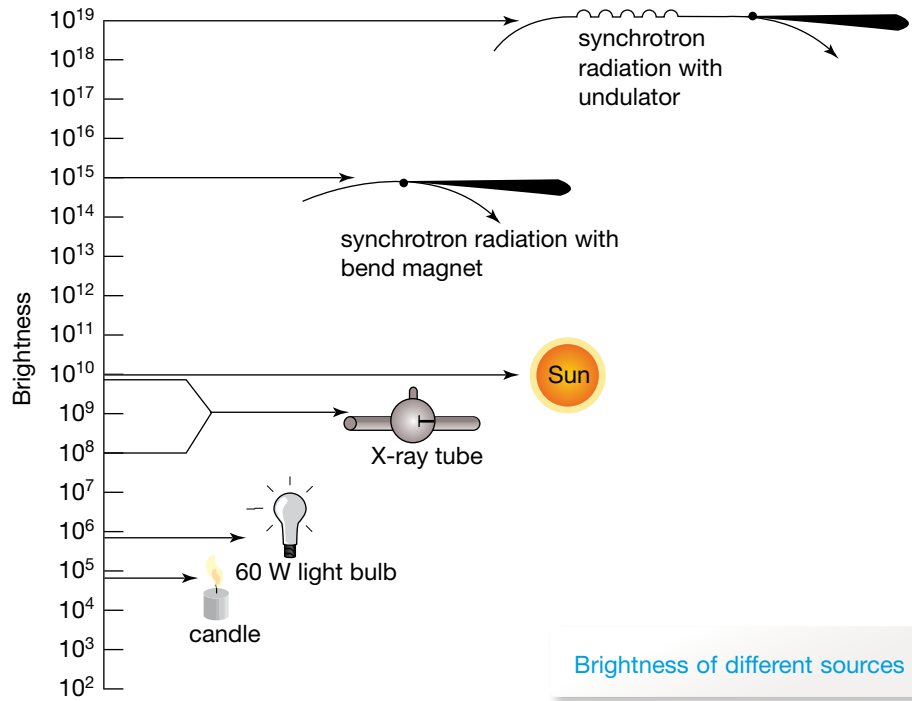

**TABLE 12.2** Comparisons of radiation: a synchrotron, a laser and an X-ray tube

	Brightness	Spectrum	Divergence
Synchrotron	Extremely intense	Continuous and wide	Very narrow
Laser	Very intense	Single frequency	Narrow
X-ray tube	Intense	Narrow, continuous but not smooth	Wide

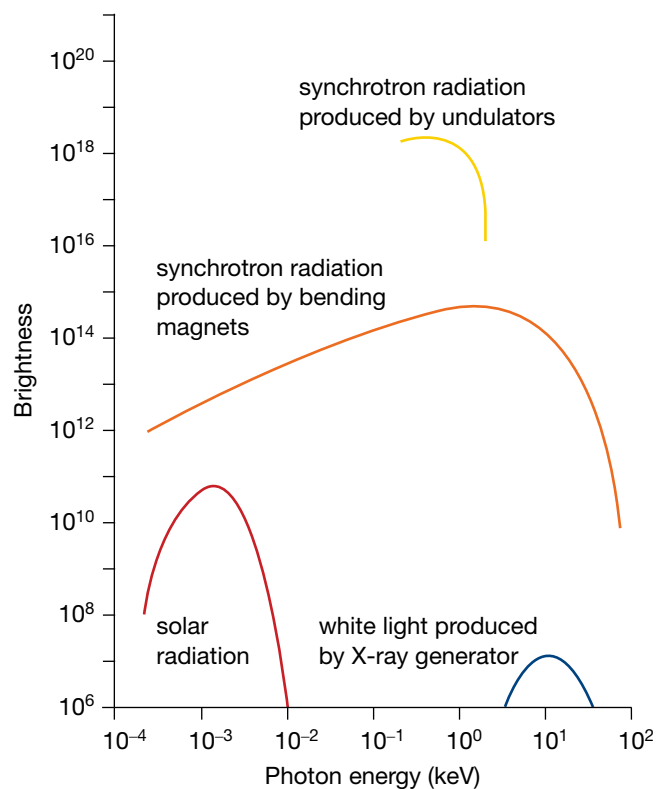

Brightness of different energy sources

These features allow the X-rays to be used to investigate the fine structure of many materials — that is, to locate specific atoms in a molecule, even a large molecule such as haemoglobin that is found in red blood cells. This information is of value to researchers across a range of fields, because it enables them to answer such questions as:

- What are the differences between malignant and non-malignant brain tumours?
- What is the structure of material, such as semiconductor **nanocrystals**, which may be used in the next generation of computers?
- What are the steps or dynamics of a chemical reaction, either an industrial situation or a biological one?

To get some idea of how X-rays can answer these questions, we should go back in time to their discovery.

## The wave behaviour of electrons

By the end of the nineteenth century, it was clear that light exhibited wave properties and could be very well modelled as consisting of waves. It was also firmly established, at that time, that matter could be modelled as consisting of particles. Early in the twentieth century, however, it was found that because of the photoelectric effect it was necessary for light to also be modelled as a particle. Was it possible that electrons, too, could exhibit wave phenomena as well as demonstrating particle behaviour?

Even though Bohr could calculate their energies, he could not explain why hydrogen electrons occupied only orbits whose energies were discrete. Why were they the only possible electron orbits? What was so special about them?

A **nanocrystal** is a very small crystal with only a few hundred to a thousand atoms.

### eBook plus

#### Weblink

The atomic lab:  
electron interference

How did atoms make sure they emitted the right frequency to ensure they landed in another stationary state?

In fact Rutherford wrote to Bohr:

*Your ideas are very ingenious and seem to work out well ... There seems to me to be one grave difficulty in your hypothesis ... namely, how does an electron decide what frequency it is going to vibrate at when it passes from one stationary state into another? It seems to me that you would have to assume that the electron knows beforehand where it is going to stop.*

### study on

Unit 4

AOS 2

Topic 2

Concept 1

**De Broglie's matter wave postulate**

Summary screen and practice questions

The **de Broglie wavelength** is the wavelength associated with a particle or discrete piece of matter.

### study on

Unit 4

AOS 2

Topic 2

Concept 1



**See more**  
De Broglie wavelength

### study on

Unit 4

AOS 2

Topic 2

Concept 3

**Wavelength and momentum for photons and matter particles**

Summary screen and practice questions

### study on

Unit 4

AOS 2

Topic 2

Concept 3



**See more**  
The momentum of photons and matter

In 1923 French nobleman Louis de Broglie (1892–1987) suggested that matter also had a wavelength associated with it. He was intrigued by the fact that light exhibited both wavelike and particle-like properties, and on this basis proposed that matter may also exhibit wavelike properties. This work was done as his PhD thesis. De Broglie proposed that the wavelength of a particle,  $\lambda$ , is related to its momentum,  $p$ , according to the following equation:

$$\lambda = \frac{h}{p} = \frac{h}{mv}$$

The constant  $h$ , Planck's constant, is related to the particle-like behaviour of light and has a value of  $6.63 \times 10^{-34}$  J s, or  $4.15 \times 10^{-15}$  eV s. The momentum of matter is given by the product of its mass and velocity.

We can appreciate why the wave properties of matter are difficult to observe. Let's calculate the **de Broglie wavelength** of a 70 kg athlete running at a speed of  $10 \text{ m s}^{-1}$ . Using the formula  $\lambda = \frac{h}{mv}$ :

$$\begin{aligned} \lambda &= \frac{6.63 \times 10^{-34} \text{ J s}}{70 \text{ kg} \times 10 \text{ m s}^{-1}} \\ &= 9.5 \times 10^{-37} \text{ m.} \end{aligned}$$

This wavelength is much too small to allow for the ready observation of diffraction effects as an athlete runs through a narrow opening! However, for a particle with a small mass, such as an electron travelling at low speed, this is not the case. Electrons accelerated through a 100 V potential difference would have a speed of approximately  $6.0 \times 10^6 \text{ m s}^{-1}$ , and because the mass of an electron is  $9.1 \times 10^{-31} \text{ kg}$  it would have a momentum of:

$$\begin{aligned} p &= mv \\ &= 9.1 \times 10^{-31} \text{ kg} \times 6.0 \times 10^6 \text{ m s}^{-1} \\ &= 5.5 \times 10^{-24} \text{ kg m s}^{-1}. \end{aligned}$$

The de Broglie wavelength for these electrons is:

$$\begin{aligned} \lambda &= \frac{6.63 \times 10^{-34} \text{ J s}}{5.5 \times 10^{-24} \text{ m s}^{-1}} \\ &= 1.2 \times 10^{-10} \text{ m.} \end{aligned}$$

This wavelength has the same order of magnitude as the spacing between atoms in many crystals. When the ratio of wavelength  $\lambda$  to slit width  $w$ ,  $\frac{\lambda}{w}$ , is sufficiently large, say greater than  $\frac{1}{10}$  for example, then diffraction effects are readily observable.

The framework for testing to see if matter had an associated wavelength had now been constructed. Researchers could build an apparatus to fire a beam of electrons of specific energy and hence specific momentum and wavelength at a crystal and see if any diffraction effects appeared.

### Sample problem 12.3

- (a) Calculate the de Broglie wavelength of a 10 g snail whose speed is  $0.10 \text{ mm s}^{-1}$ .  
(b) How fast would an electron have to travel to have a de Broglie wavelength of  $1 \mu\text{m}$ ?

**Solution:** (a) The de Broglie wavelength is given by the expression:

$$\lambda = \frac{h}{p} = \frac{h}{mv}.$$

Thus

$$\begin{aligned}\lambda &= \frac{6.63 \times 10^{-34}}{10 \times 10^{-3} \times 0.10 \times 10^{-3}} \\ &= 6.63 \times 10^{-33} \text{ m},\end{aligned}$$

keeping in mind that mass must be in kilograms and velocity in metres per second.

- (b) The expression  $\lambda = \frac{h}{mv}$  can be transposed to make  $v$  the subject. Thus  $v = \frac{h}{m\lambda}$ .

$$\begin{aligned}v &= \frac{6.63 \times 10^{-34}}{9.1 \times 10^{-31} \times 1 \times 10^{-6}} \\ &= 728.571 \\ &= 7.3 \times 10^2 \text{ m s}^{-1} \text{ (to 2 significant figures)}\end{aligned}$$

The speed of the electron is  $7.3 \times 10^2 \text{ m s}^{-1}$ .

### Revision question 12.3

Which has the greater de Broglie wavelength: a proton ( $m = 1.67 \times 10^{-27} \text{ kg}$ ) travelling at  $2.0 \times 10^4 \text{ m s}^{-1}$  or an electron ( $m = 9.1 \times 10^{-31} \text{ kg}$ ) travelling at  $2.0 \times 10^5 \text{ m s}^{-1}$ ?

Finally, it is worth noting that the de Broglie wavelength associated with a piece of matter is inversely proportional to both the speed and mass. Hence, to create matter with large wavelengths, necessary for wave properties to manifest themselves, matter has to travel slowly and have little mass. Since electrons have a mass that is approximately  $\frac{1}{1800}$  that of a proton or neutron, it is easier to detect the wave properties of electrons over those of other fundamental particles such as protons and neutrons.

## Matter waves show themselves

De Broglie suggested conducting an experiment to confirm whether or not a beam of electrons could be diffracted from the surface of a crystal. The openings between atoms could be used as a diffraction grating in much the same way that X-rays were diffracted by thin crystals as suggested by Max von Laue in 1912. Clinton Davisson (1881–1958) and Lester Germer (1896–1971) directed a beam of electrons at a metal crystal in 1927, and the scattered electrons came off in regular peaks as shown in the figure below.

#### study on

Unit 4 **Diffraction of electrons**

AOS 2 Summary screen and practice questions

Topic 2

Concept 2

This pattern is indicative of diffraction taking place with individual electrons as they scattered off the crystal surface. In fact, the wavelength determined from the diffraction experiments was exactly as predicted by the de Broglie wavelength formula. In this way, electrons were shown to have wavelike properties. Since then, protons, neutrons and, more recently, atoms have been shown to exhibit wavelike properties, but it begs the question: if matter can exhibit wave characteristics, what is it that is 'waving'? More technically, the question is what physical variable is it that has an amplitude and phase?

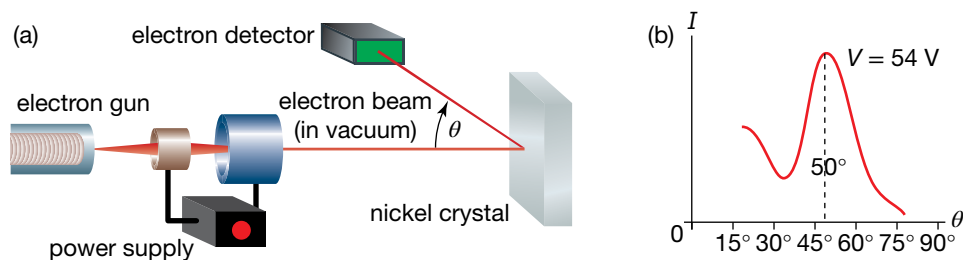

The Davisson and Germer experiment. (a) Electrons emitted from a heated filament are accelerated towards the crystal surface. The intensity of reflected electrons is recorded as the angle of the detector is changed. (b) Electron intensity as a function of angle

### Sample problem 12.4

What would be the dimensions of the array of slits required to observe diffraction of 60 g tennis balls travelling at  $30 \text{ m s}^{-1}$ ? What about electrons travelling at  $3.0 \times 10^6 \text{ m s}^{-1}$ ?

**Solution:** To observe diffraction effects, the size of the opening needs to be of the same order of magnitude or smaller than the wavelength of the waves. We can see below that the de Broglie wavelength of the tennis ball is of the order of  $10^{-34} \text{ m}$  and the electron of the order of  $10^{-10} \text{ m}$ .

The de Broglie wavelength of:

the tennis ball

$$\lambda = \frac{6.6262 \times 10^{-34} \text{ J s}}{0.060 \text{ kg} \times 30 \text{ m s}^{-1}} \\ = 3.7 \times 10^{-34} \text{ m}$$

the electron

$$\lambda = \frac{6.6262 \times 10^{-34} \text{ J s}}{9.109 \times 10^{-31} \text{ kg} \times 3.0 \times 10^6 \text{ m s}^{-1}} \\ = 2.4 \times 10^{-10} \text{ m}$$

The distances between atoms in a crystal are of the order of  $10^{-10} \text{ m}$ , so we could observe diffraction and interference when these electrons are scattered from a crystal. It is not surprising that we never observe diffraction and interference effects with tennis balls, due to the extremely small wavelength,  $10^{-34} \text{ m}$ , that they have.

### Revision question 12.4

At what speed would neutrons (mass =  $1.67 \times 10^{-27} \text{ kg}$ ) have to be moving for them to demonstrate diffraction effects when passing through an array of slits of width  $1 \mu\text{m}$ ?

### Sample problem 12.5

What voltage is required to accelerate electrons to a speed of  $3.0 \times 10^6 \text{ m s}^{-1}$ ?

**Solution:** To accelerate electrons to a speed of  $3.0 \times 10^6 \text{ m s}^{-1}$ , we need to calculate the work done by a voltage  $V$ .

$$\begin{aligned}\Delta E_{\text{k electron}} &= \frac{1}{2} m_e v^2 \\ \Delta E_{\text{k electron}} &= -\Delta E_{\text{p electron}} \\ &= q_e V\end{aligned}$$

where

$q_e$  is the *magnitude* of the charge of the electron.

$$\begin{aligned}\Rightarrow V &= \frac{m_e v^2}{2q_e} \\ &= \frac{9.109 \times 10^{-31} \text{ kg} \times (3.0 \times 10^6 \text{ m s}^{-1})^2}{2 \times 1.6 \times 10^{-19} \text{ C}} \\ &= +26 \text{ V}\end{aligned}$$

So, only 26 V is required to accelerate an electron to  $3 \times 10^6 \text{ m s}^{-1}$ .

### Revision question 12.5

Calculate the speed of electrons accelerated from rest by an electron gun whose voltage is set at 13 V.

## Electrons through foils

Intense, creative interest in fundamental physics ran in the Thomson family. Remember, it was J.J. Thomson whose ingenious experiment yielded the measurement of the charge-to-mass ratio of the electron. At that time there was no doubt that electrons were extremely well modelled as particles. However, G.P. Thomson, son of J.J., continued the exploration of the wave properties of electrons. He fired electrons through a thin polycrystalline metallic foil. The electrons had a much greater momentum than those used by Davisson and Germer. They were able to penetrate the foil and produce a pattern demonstrating diffraction of the electrons by the atoms of the foil — further evidence for wavelike behaviour of electrons. The polycrystalline nature of the foil results in a series of rings of high intensity. A single crystal would produce a pattern of spots. Thomson used identical analysis techniques to those used for diffraction of X-rays through foils, to confirm the de Broglie relationship.

Both Thomsons were awarded Nobel prizes — J.J. in 1897 for measuring a particle-like characteristic of electrons, and G.P. in 1937, together with C.J. Davisson, for demonstrating their wave properties.

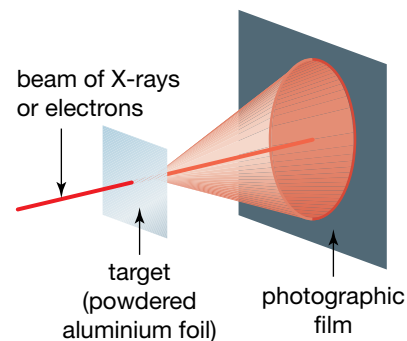

Diffraction of X-rays and electrons by polycrystalline foils

Just as light requires a wave model and a particle model to interpret and explain how it behaves, so too does matter: it behaves like a particle in the sense that work can be done on it to increase its kinetic energy under the action of forces, but matter can also be made to diffract through sufficiently narrow openings and around obstacles. This requires a wave model and the de Broglie wavelength is used to determine the extent of matter's wave behaviour. It appears we need both a particle and a wave model for both light and matter. Electrons passed through a voltage  $V$  acquire a kinetic energy  $E_k$  equal to  $qV$ . Since they have kinetic energy, they also possess momentum and, according to de Broglie, a wavelength. We can determine a useful relationship between the de Broglie wavelength of an electron ( $\lambda$ ) and the accelerating voltage ( $V$ ) used.

By equating the kinetic energy of the electron ( $E_k$ ) to the work done by an accelerating voltage acting on an electron ( $q_eV$ ), we get:

$$E_k = \frac{1}{2}m_e v^2 = q_e V$$

$$m_e v^2 = 2q_e V$$

$$m_e^2 v^2 = 2m_e q_e V.$$

The left-hand side is just the square of the momentum of the electron, and hence by taking the square root of both sides:

$$p = \sqrt{2m_e q_e V} \quad \text{or} \quad p = \sqrt{2m_e E_k},$$

remembering that  $E_k$  is equal to  $q_e V$ .

Since the de Broglie wavelength  $\lambda$  is given by  $\frac{h}{p}$ , it follows that:

$$\lambda = \frac{h}{\sqrt{2m_e q_e V}}$$

for a given accelerating voltage  $V$ , or

$$\lambda = \frac{h}{\sqrt{2m_e E_k}}$$

when the kinetic energy  $E_k$  of the electron in joules is known.

### Sample problem 12.6

Some of the X-rays used in G. P. Thomson's experiment had a wavelength of  $7.1 \times 10^{-11}$  m. Confirm that the 600 eV electrons have a similar wavelength.

**Solution:** Electrons of energy 600 eV have passed through a voltage equal to 600 V; thus, their energy is  $1.6 \times 10^{-19} \times 600$  J. From this their de Broglie wavelength can be determined. Use the relationship:

$$\lambda = \frac{h}{\sqrt{2m_e E_k}}.$$

Thus:

$$\lambda = \frac{6.63 \times 10^{-34}}{\sqrt{2 \times 9.1 \times 10^{-31} \times 1.6 \times 10^{-19} \times 600}}$$

$$= 5.0 \times 10^{-11} \text{ m.}$$

This is a similar value to the  $7.1 \times 10^{-11}$  m wavelength of the X-rays.

### Revision question 12.6

- (a) X-rays of wavelength 0.053 nm are used to investigate the structure of a new plastic. If a beam of electrons are to be used instead of X-rays, what voltage should be used to accelerate these electrons?
- (b) Which has a greater wavelength: a 100 eV photon or a 100 eV electron?

### Sample problem 12.7

Consider a photon and an electron that both have a wavelength of  $2.0 \times 10^{-10}$  m.

- (a) Calculate the momentum of the photon and the electron. What do you notice?
- (b) Calculate the energy of the photon and the electron. What do you notice?
- (c) Summarise what you have found concerning the momentum and energy of a photon and an electron with the same wavelength.

**Solution:**

- (a) The momentum of the photon and the electron are governed by the same equation, namely  $p = \frac{h}{\lambda}$ . Hence, both the photon and the electron will have the same momentum because they have the same associated wavelength. Thus:

$$\begin{aligned} p &= \frac{6.63 \times 10^{-34}}{2.0 \times 10^{-10}} \\ &= 3.3 \times 10^{-24} \text{ N}\cdot\text{s}. \end{aligned}$$

We notice here that both the photon and the electron have the same momentum.

- (b) To determine the energy of an object from its momentum, we now have to ask if it is a photon or an object with mass. The relations are different. For the photon,  $E = pc$ . Thus:

$$\begin{aligned} E &= 3.3 \times 10^{-24} \times 3.0 \times 10^8 \\ &= 9.9 \times 10^{-16} \text{ J or } 6.2 \text{ keV}. \end{aligned}$$

For the electron, however,  $E = \frac{p^2}{2m}$ . Thus:

$$\begin{aligned} E &= \frac{(3.3 \times 10^{-24})^2}{2 \times 9.1 \times 10^{-31}} \\ &= 6.0 \times 10^{-18} \text{ J or } 37 \text{ eV}. \end{aligned}$$

The electron has substantially less kinetic energy than the photon, even though they have the same momentum.

- (c) Light and matter with the same wavelength will have the same momentum, and vice versa. However, when photons and electrons have the same momentum, they will not necessarily have the same energy. In the problem above, the photon has substantially more energy than the electron.

### Revision question 12.7

Consider a photon and an electron that both have a wavelength of  $1.0 \times 10^{-10}$  m.

- (a) Calculate the momentum of the photon and the electron. What do you notice?
- (b) Calculate the energy of the photon and the electron. What do you notice?



## study on

Unit 4

AOS 2

Topic 3

Concept 7

**Electron standing waves and atomic stability**

Summary screen and practice questions

# Electrons, atoms and standing waves

Individual electrons act like waves when they are diffracted by atoms in crystals. Do electrons *in* the atoms also exhibit wavelike properties? They certainly do! Thinking of electrons behaving like waves solved the puzzle of stationary states. This wave model for electrons that are bound within atoms also neatly explained why atoms absorb and emit photons of only particular frequencies, and provided the answers to Rutherford's questioning of the Bohr model of the atom. In essence, only waves whose de Broglie wavelength multiplied by an integer  $n\lambda$  set equal to the circumference of a traditional electron orbit are allowed to exist due to these waves being the only ones able to constructively interfere to produce a standing wave. De Broglie speculated about the electron in a hydrogen atom displaying wavelike behaviour in 1924. A complete description of the hydrogen atom awaited a more sophisticated mathematical treatment called quantum mechanics. The fundamentals of this model were developed by Erwin Schrödinger and Werner Heisenberg later in the 1920s.

## Louis de Broglie's picture

Louis de Broglie pictured the electron in a hydrogen atom travelling along one of the allowed orbits around the nucleus, together with its associated wave. In de Broglie's mind the circumference of each allowed orbit contained a *whole number* of wavelengths of the electron-wave so that it formed a standing wave around the orbit. Thus,  $n\lambda = 2\pi r$  or  $\lambda = \frac{2\pi r}{n}$  fixes the allowed wavelength. An electron-wave whose wavelength was slightly longer, or shorter, would not join onto itself smoothly. It would quickly collapse due to destructive interference. Only orbits corresponding to standing waves would survive. This is shown below. The concept is identical to the formation of standing waves on stringed instruments.

It is worth noting that the standing waves produced on a stringed instrument of length  $l$  have a series of possible wavelengths  $\lambda_n = \frac{2l}{n}$  where  $n$  is a positive integer (1, 2, 3 and so on). This series of wavelengths is called a harmonic series. At this level of physics, which is only an introduction to the conceptual nature of quantum mechanics, the harmonic series provides for a series of associated momenta that are discrete in value. This in turn provides for a series of energy states that are also discrete. This connection is in complete agreement with the observation of emission and absorption spectra. When you pluck a guitar string, only certain frequencies are produced. Likewise, when you energise an atom, only certain energy levels are able to be sustained, resulting in the emission of well-defined frequencies of light in the form of individual photons.

A model of the atom showing the electron as a standing wave

(a)

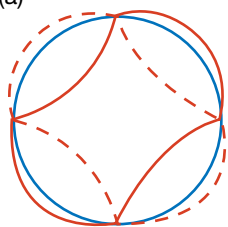

circumference =  
2 wavelengths  
 $n = 2$   
(first excited state)

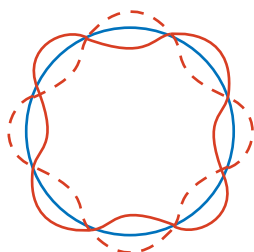

circumference =  
4 wavelengths  
 $n = 4$   
(third excited state)

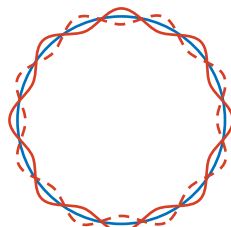

circumference =  
9 wavelengths  
 $n = 9$   
(eighth excited state)

(b)

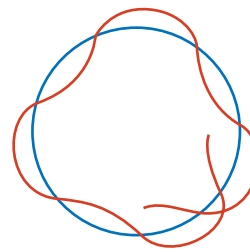

Unless a whole number of wavelengths fit into the circular hoop, destructive interference occurs and causes the vibrations to die out rapidly.

In de Broglie's model of the atom, electrons are viewed as standing waves. It is this interpretation that provides a reasonable explanation for the emission spectra of atoms. It answers Rutherford's remark to Bohr (see page 309). When a guitar string is plucked, how does it know what frequencies to vibrate at? The answer is: the frequencies that equate to the standing waves with wavelengths compatible with the length of the string.

Electrons viewed as standing waves can exist only in stable orbits with precise or discrete wavelengths. This implies that the electrons can have only discrete quantities of momentum. This in turn implies that the electrons can have only discrete amounts of energy. Energy transitions that are made by electrons occur in jumps from one high-energy standing wave to another standing wave of lower energy. In this way the emission spectra and, hence, absorption spectra can be understood as arising from transitions between quantised energy levels due to electrons having a wave-like character.

## Waves or particles?

It's a consistent story — light displays both wave and particle behaviour and so do electrons and all other forms of matter. The two models are complementary. You observe behaviour consistent with wave properties or particle properties, but not the two simultaneously. Remember how William Bragg expressed it: 'On Mondays, Wednesdays and Fridays light behaves like waves, on Tuesdays, Thursdays and Saturdays like particles, and like nothing at all on Sundays'? This delicate juggling of the two models by both light and matter is known as **wave-particle duality**.

There have been many conceptual hurdles for physicists in arriving at this amazingly consistent view of the interaction between light and matter. Their guiding questions always kept them probing for the evidence. Observations and careful analysis gave them the answers. Imagination, creativity and ingenuity were vital in their search for a more complete picture of light and matter.

We now know that both light and matter can exhibit both wave-like and particle-like behaviour, depending on the types of experiments performed. For example, when light strikes a material object, it transfers energy as if it is a particle (the photoelectric effect), but when light passes through a narrow opening or a pair of slits, it acts as if it is a wave. Likewise, matter can have work done on it via well-understood forces accelerating it, but matter can also be diffracted when it passes through a crystal, producing diffraction patterns similar to those of X-rays. Also, the behaviour of electrons within atoms can only be understood by treating them as a type of wave phenomena.

A more detailed model for the seemingly paradoxical result of both wave-like and particle-like behaviour for both light and matter was developed in the 1910s and 1920s. The model is called quantum mechanics, and in it wave and particle behaviour for both light and matter are unified successfully.

## Photons have wave properties too

We do not need a beam of light to observe wave effects — every single photon has wave properties. Geoffrey Taylor set out to demonstrate this in 1909, while he was a University of Cambridge student. Taylor photographed the diffraction pattern in the shadow of a needle, but his photograph took three months of light exposure to produce. He used an extremely dim source, a gas flame, together with several smoked glass screens, to illuminate the entrance slit of a light-tight box. Taylor measured the light intensity entering the box, and estimated that only  $10^6$  photons entered the box each second. This may not sound like a low intensity, but with a photon speed of  $3 \times 10^8 \text{ m s}^{-1}$  the average distance between photons was 300 m!

---

**Wave-particle duality** describes light as having characteristics of both waves and particles. This duality means that neither the wave model nor the particle model adequately explains the properties of light on its own.

Using a box 1 m long Taylor could be sure that rarely was there more than one photon travelling through it at any one time, so a vast majority of photons travelled through the box unaccompanied. An image appeared on the photographic plate after three months just as Taylor expected — a pattern of light and dark bands in the shadow of the needle. Taylor compared it to the pattern obtained in a short time with an intense light source and stated: ‘In no case was there any diminution in the sharpness of the pattern.’ His experiment demonstrated that interference occurred photon by photon, that the wave of a single photon filled the box, interfering with itself as it diffracted past the edges of the needle.

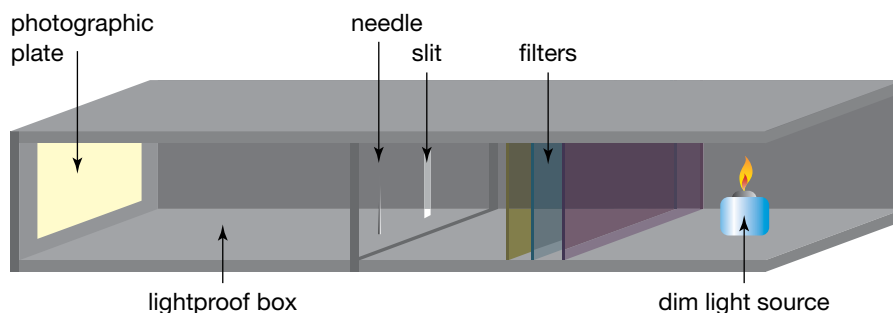

Taylor's experiment

Taylor's experiment invites us to imagine watching an interference pattern build up on the photographic plate. The first few photons would produce an apparently random sprinkling of spots, each spot due to a single photon changing the chemical state of an ion in the photographic film. As the spots accumulated they would start to overlap and gradually a pattern would emerge from the randomness. During this process we would never be able to predict precisely where the next photon would strike the plate. The pattern predicted by the wave nature of the light would allow us to predict only the *probability* of a photon reaching a particular point. This pattern of probabilities would be clear only after many photons had made their mark.

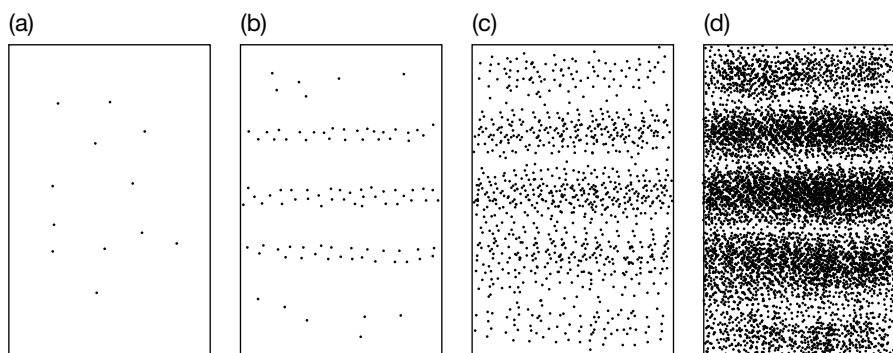

Imagine the gradual build-up of photon spots into a double-slit interference pattern.

Taylor's experiment is a beautiful demonstration of wave-particle duality. The wave and particle characteristics of light are entangled and cannot be separated. We need both models. Sir William L. Bragg expressed the idea in this way: ‘On Mondays, Wednesdays and Fridays light behaves like waves, on Tuesdays, Thursdays and Saturdays like particles, and like nothing at all on Sundays.’ In fact, even when light is travelling particle by particle, its wave characteristics are there at the same time, determining the outcome.

Similar experiments have been done with electrons and neutrons, and more recently with large molecules. In all cases, the wavelike behaviour of these individual entities when passing through openings has demonstrated

### study on

- Unit 4 **Single photon double-slit experiment**
- AOS 2
- Topic 3 Summary screen and practice questions
- Concept 9

### eBook plus

#### eLesson

The wave-particle duality of light  
eles-0028

#### Interactivity

The wave-particle duality of light  
int-0052

wave-particle duality in the form of diffraction effects. It seems the entities pass through the opening and self-interfere in the process. Importantly, they do this one entity at a time. Over an extended period, a statistical distribution builds up of where these entities go, recorded by where they strike a screen. The distribution is consistent with a wave model analysis for coherent waves of the one wavelength passing through an opening, whether it is a single slit, a double slit or any complicated array of openings.

## Heisenberg's uncertainty principle

In the 1920s, as quantum mechanics was being developed, it became apparent that the exact location of an object,  $x$ , and the exact momentum of the object,  $p$  were impossible to know simultaneously with complete precision. This applied to both light and matter. In essence, if you knew exactly where an object was, you would not know exactly what it was doing, and vice versa. Curiously this realisation is not unlike one of Zeno's paradoxes articulated over 2000 years ago, relating to the motion of an arrow. In modern terms the uncertainty principle can be written in terms of the uncertainty in  $x$ ,  $\Delta x$ , and the uncertainty in  $p_x$ ,  $\Delta p_x$ , where  $x$  is the position and  $p_x$  is the momentum of an object parallel to the  $x$ -axis.

Before we continue, the concept of the 'wave packet' needs to be introduced. A wave packet is a mathematical entity that has two features. It is a periodic function and it has an amplitude that varies. From this function, the position of the entity can be recorded with some imprecision. The momentum of the entity can also be recorded, since the function has a wavelength, but this also is imprecise.

### study on

Unit 4

**Heisenberg's uncertainty principle**

AOS 2

Topic 3

Summary screen and practice questions

Concept 10

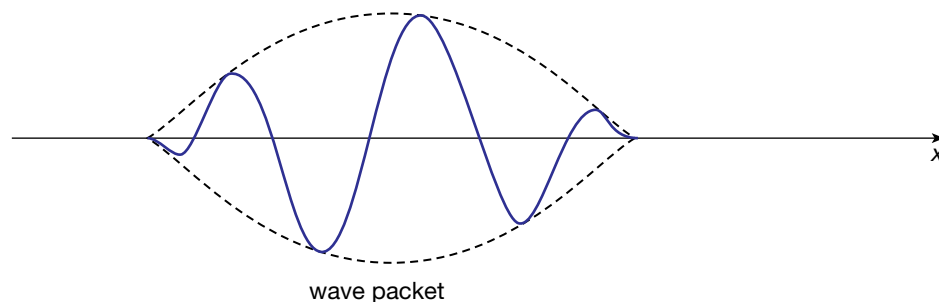

A wave packet

Recall that the momentum of an object is given by the equation  $p = \frac{h}{\lambda}$ . If the wavelength of an object cannot be precisely measured, then the momentum of that object is also uncertain. The diagram below illustrates two wave packets.

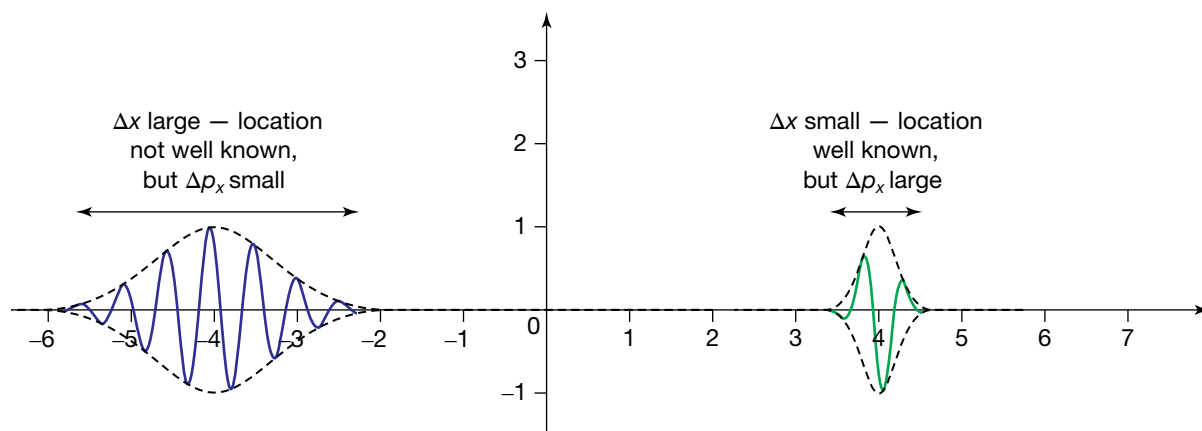

Two wave packets — on the left a packet with a large  $\Delta x$ , and on the right a packet with a small  $\Delta x$

The wave packet on the left has a large uncertainty in location —  $\Delta x$  is large — but the packet contains enough information to precisely determine the wavelength and hence the momentum. In the wave packet on the right, however,  $\Delta x$  is small, and as a consequence the wavelength is less able to be precisely determined. Hence there is an intrinsic uncertainty,  $\Delta p$ , in being able to determine the object's momentum.

A common form of Heisenberg's uncertainty principle asserts that:

$$\Delta x \times \Delta p_x \geq \frac{h}{4\pi}$$

where  $h = 6.63 \times 10^{-34}$  J s.

As an introductory example, let us say that the position along the  $x$ -axis of an electron is uncertain to the extent that  $\Delta x = 1 \times 10^{-10}$  m. Using the above inequality, this would imply that the uncertainty in the momentum of the electron,  $\Delta p_x$ , was approximately  $5 \times 10^{-25}$  N s.

It is important to point out here that we are not discussing the position or momentum of an object, but rather the uncertainty or inherent error in these quantities. Decreasing the uncertainty in  $x$  would serve to increase the uncertainty in  $p_x$ , the momentum of the electron parallel to the  $x$ -axis. The more confined or well-known that the electron's position is along the  $x$ -axis, the more uncertain its motion becomes along that axis, because its momentum becomes more uncertain. This concept can be used to appreciate why electrons in atoms are simultaneously delocalised and their motion unpredictable. But it also helps us to appreciate the significance of single-slit diffraction, where a beam of objects spreads out after traversing an opening. Traditionally these objects have been photons or subatomic particles such as electrons, but recently in Austria a research team succeeded in demonstrating diffraction effects using very large molecules.

Let us now consider a beam of objects moving in a fixed direction at a steady rate but heading straight towards a single slit of width  $\Delta x$ . This opening defines not only the width of the beam as the objects move from one side of the slit to the other side (notice we avoid saying that the objects went through the slit) but the extent of the uncertainty,  $\Delta x$ , in the direction perpendicular to the beam. Because of this confinement associated with the width of the slit, the objects will have an uncertainty of  $\Delta p_x$  associated with their movement on the far side of the slit:  $\Delta p_x \geq \frac{h}{4\pi\Delta x}$ . It is clear to see that when the width of the slit is smaller, that is  $\Delta x$  is smaller, then the uncertainty in the momentum,  $\Delta p_x$ , is larger.

We should not be surprised to find objects leaving the slit with momentum directed either to the left or to the right of the slit, in apparent violation of the conservation of momentum. This is because objects passing through an opening may change direction due to the uncertainty principle. The smaller the opening is, the more likely that there will be change in the direction of an object in the beam as it emerges from the slit.

We know from diffraction experiments that reducing the width of the opening causes the diffraction pattern to spread out, and now we have an explanation for why this is the case. The spreading out is due to the uncertainty of the momentum of the beam of particles along the  $x$ -axis — the bigger the width of the single slit, the smaller the uncertainty in the momentum of the objects in the beam, and the higher the probability that they continue to travel in the direction they were travelling in on the other side of the slit. This relationship is illustrated in the diagram below, where a beam of objects is incident on a single slit of width  $\Delta x$ . The beam before the slit is directed along the  $y$ -axis with no momentum in the  $x$ -axis. The objects on the other side of the

slit have an uncertainty in their momenta represented by the double-ended arrow parallel to the  $x$ -axis due to traversing the single slit. It is the presence of the single slit that creates an uncertainty in the position of an object in the beam parallel to the  $x$ -axis, which in turn is associated now with an uncertainty in the momentum of the beam along the  $x$ -axis according to the Heisenberg uncertainty principle.

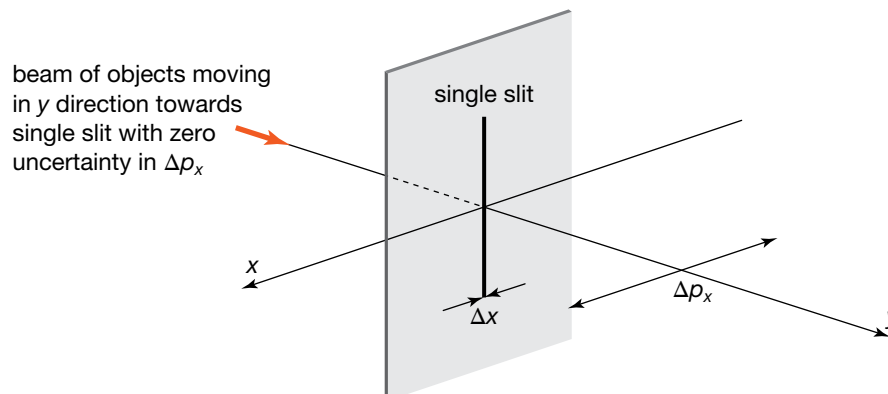

Again, it is important to avoid saying that the objects passed through the slit; it is simply that at one stage they were on one side of the slit, and later in time they were on the other side of the slit. Using this language ensures that we avoid the problem associated with a similar double-slit experiment: that is, if an object, be it a photon or a piece of matter, is on one side of the pair of slits and then later on the other side, which opening did the object pass through? We also avoid any problem with a beam of objects spreading out when traversing a narrow opening. In applying quantum mechanics to a double-slit type experiment, it is not helpful to ask the obvious question of which slit the object passed through. Experiments designed to measure which of the two slits an object passes through fail to simultaneously detect the interference pattern associated with a double slit when researchers measure which opening an object passes through, just as in a single-slit experiment researchers cannot simultaneously observe a diffraction pattern and where an object is as it passes through the single slit.

There are many levels on which Heisenberg's principle can be understood, but a rigorous and sophisticated interpretation is beyond the current course due to its mathematical complexity. A simple explanation is more helpful at this stage. In order for the wavelength of a wave to have a measurable value, the wave should consist of a least one cycle. The greater the number of complete cycles, the easier it is to ascertain a value for the wavelength. For a wave of less than one cycle, the error associated with any wavelength measurement would increase. This means that for a small error assessment of an object's momentum its associated wave should consist of many cycles: the more cycles, the smaller the error in momentum, due to a more accurate result for the wavelength. However, a wave pulse consisting of many cycles implies that the exact location of the object associated with the wave is more uncertain; all we know is that the object is likely to be found somewhere between the start and finish of the wave packet. Hence, to measure what an object is doing (via its momentum) we have to forsake knowing where it is, and vice versa.

This trade-off of knowledge, arising because both light and matter manifest both particle (localised) and wave (delocalised) behaviours, forms the basis of the Heisenberg uncertainty principle. The uncertainty principle spelled the end for determinism, a philosophical belief arising from Newtonian mechanics in which the universe is considered to be a machine fully explainable by forces alone.

For the interested reader, it is worth mentioning that the variables  $x$  and  $p_x$  are in fact probability density functions indicating the probability of finding an

object at a point or the probability of having it a particular momentum. The quantity  $\Delta x$  is the standard deviation of  $x$ , giving information about the distribution in location of an object, and  $\Delta p_x$  is the standard deviation of  $p_x$ , giving information about the momentum distribution of an object in the  $x$ -direction.

Finally, each of the two variables  $x$  and  $p$  is the Fourier transform of the other. The variables  $x$  and  $p$  are referred to as complementary variables, and a Fourier transform is a mathematical process for finding one complementary variable given the other, for example finding  $p$  given  $x$  or vice versa. Another pair of complementary variables is energy,  $E$ , and time,  $t$ . Not surprisingly, there is an uncertainty principle here as well:  $\Delta E \times \Delta t \geq \frac{h}{4\pi}$ . This relationship can be interpreted as stating that energy conservation may be violated by an amount  $\Delta E$  provided it is done within a time  $\Delta t$  consistent with the Heisenberg inequality, just as how momentum conservation may be violated by an amount  $\Delta p_x$  provided it is done within an interval of space  $\Delta x$ .

It is a significant intellectual breakthrough to not only have rules about nature but also have rules about how to break or violate those rules. You will learn more about this if you study Physics at university.

### Sample problem 12.8

A research scientist is working with a beam of photons produced by a laser of wavelength 640 nm. The beam of photons is directed onto a single slit. A screen is positioned on the other side of the slit, and a single-slit diffraction pattern is observed. Consider one of the photons in the beam.

- Determine the momentum of this photon in the direction of the beam and state the momentum perpendicular to the beam before the photon reaches the slit.
- The photons are incident on a narrow single slit of width  $3.2 \times 10^{-7}$  m. Calculate the uncertainty in the momentum of the photon perpendicular to the beam when it appears on the other side of the single slit.
- Explain in terms of the Heisenberg uncertainty principle why a traditional diffraction pattern would be observed in terms of the momentum in the direction of the beam compared to the momentum uncertainty perpendicular to the beam.

**Solution:** (a) Use the relation  $p = \frac{h}{\lambda}$ .

$$p = \frac{6.63 \times 10^{-34}}{640 \times 10^{-9}} \\ = 1.0 \times 10^{-27} \text{ N s in the direction of the beam}$$

The momentum perpendicular to the beam is 0 N s before incidence on the single slit. This means that the uncertainty in the location of the photon in the beam is significant and is associated with the aperture of the laser.

- (b) Use the relation  $\Delta x \times \Delta p_x \geq \frac{h}{4\pi}$  with  $\Delta x = 3.2 \times 10^{-7}$  and solve for  $\Delta p_x$ . Thus,

$$\Delta p_x \geq \frac{h}{4\pi \Delta x} \\ \geq \frac{6.63 \times 10^{-34}}{4\pi \times 3.2 \times 10^{-7}} \\ \geq 1.6 \times 10^{-28} \text{ N s.}$$

On the other side of the slit, the photon has an uncertainty in its momentum perpendicular to the beam of at least  $1.6 \times 10^{-28}$  N s.

- (c) Before they reach the slit, photons have momentum parallel to the beam and zero momentum perpendicular to the beam. They all travel in a straight line towards the single slit. When they appear on the other side of the slit, they still have the same momentum in the direction of the beam, but they now have an uncertainty in their momentum perpendicular to the beam. Importantly, this uncertainty allows for the photons to have some motion either to the left or to the right of the slit. Momentum is a vector quantity and thus the photons will travel in a variety of directions, not necessarily parallel to the incident beam, due to the narrowness of the opening being associated with an increase in the uncertainty of perpendicular momentum. The uncertainty is  $1.6 \times 10^{-28} \text{ N s}$ , which is about  $\frac{1}{6}$  of the momentum of a photon in the beam. As a result, diffraction will be readily observable.

### Revision question 12.8

An experiment consists of a beam of electrons incident on an opening of order  $10^{-10} \text{ m}$ . What would be the order of magnitude of the uncertainty in the momentum of electrons parallel to the width of this opening?

## Why classical laws of physics are unable to model motion at very small scales

It is now clear why classical laws of physics are unable to model motion at very small scales. For large-scale events, the uncertainty of position has an insignificant effect on the uncertainty of momentum and vice versa. This is because Planck's constant is too small to be of any consequence when dealing with large objects. For example, if the uncertainty in the position of a moving cricket ball is  $1 \times 10^{-6} \text{ m}$ , this leads to an uncertainty in the ball's momentum of approximately  $10^{-28} \text{ N s}$ . A moving cricket ball with mass  $50 \text{ g} = 5.0 \times 10^{-2} \text{ kg}$  and speed  $20 \text{ m s}^{-1}$  has a momentum of  $1 \text{ N s}$ . The uncertainty in the ball's momentum compared to its actual momentum is negligible, in this case  $10^{28}$  times smaller.

However, if we now investigate objects on very small scales, Planck's constant becomes significant. If the uncertainty in the position of an electron in an atom is  $10^{-10} \text{ m}$ , then the uncertainty in its momentum is now on the order of  $10^{-24} \text{ N s}$ . An electron with energy  $1 \text{ eV}$  ( $1.6 \times 10^{-19} \text{ J}$ ) has a momentum of  $5.4 \times 10^{-25} \text{ N s}$  (using the equation  $p = \sqrt{2mE_k}$ ). In this case, the uncertainty in the momentum of the electron is larger than the magnitude of the momentum of the electron. An experimental arrangement would be incapable of ascertaining with any degree of certainty what this individual electron was doing, if indeed such an experimental question could be resolved.

For a reader new to this area of physics, they might be inclined to state that with better and more refined measuring equipment the ability to measure either location or motion could be improved. But the uncertainty principle is not about refinements in measurements; rather, it is an assertion about what can and can't be known simultaneously and to what level of precision — an insignificant fact when observing day-to-day phenomena, but central to appreciating the motion of very small objects. The pathway to knowledge is never complete, but in modern physics a significant achievement was established in the 1920s, when the limits to our understanding were quantified by a simple relationship that united the contradictory modelling in terms of particles and waves simultaneously.



# Chapter review



## Summary

- The behaviour of electrons — in particular, their deflection by electric and magnetic fields, and their electric charge and mass — is strong evidence for the particle-like nature of electrons.
- Atoms emit light of precise frequencies. This light, when passed through a spectrometer, is known as an emission spectrum.
- All atoms of the same element emit the same spectrum. Different elements produce their own distinctive spectra.
- In contrast, a hot solid or liquid material emits a continuous spectrum that is independent of composition. These sources are often referred to as incandescent light sources.
- Synchrotron radiation is produced when a charged particle accelerates. In the storage ring of a synchrotron, the charged particles move in circular paths and hence are accelerating; the radiation is very intense, comes in a narrow beam and covers a broad range of frequencies.
- LEDs produce light from spontaneous emission when electrons fall from high to low energy levels or bands within a semiconductor. The loss in electron energy equals the energy of the emitted photon.
- Lasers produce light by a process called stimulated emission. The radiation produced is monochromatic and coherent.
- Absorption spectra consist of a continuous spectrum with dark lines corresponding to particular missing wavelengths. In general, these dark lines correspond to the bright lines of emission spectra for a particular gas.
- To account for emission spectra, Neils Bohr proposed a radical model where electrons within atoms have stable orbits but only discrete energy levels are allowed.
- When an atom jumps from a high energy level,  $E_{\text{initial}}$ , to a lower energy level,  $E_{\text{final}}$ , resulting in a difference,  $\Delta E$ , a photon of light is emitted with frequency,  $f$ , according to the equation  $hf = \Delta E$ . Hence, the observation of emission spectra having precise frequencies is evidence for atoms having discrete energy levels.
- The best model for atoms having discrete energy levels is to interpret electrons in atoms as behaving as a standing wave. The allowable standing waves are known as orbitals.
- In 1924 Louis de Broglie suggested that electrons may exhibit wave properties under suitable conditions. He proposed a diffraction experiment using a beam of electrons and a crystal to act as a diffraction grating.
- The de Broglie wavelength,  $\lambda$ , can be determined from the momentum,  $p$ , according to the equation  $\lambda = \frac{h}{p}$ . Remember also that the momentum of a particle is given by  $p = mv$ , where  $m$  is the mass and  $v$  is the speed.
- Diffraction effects can be observed with waves when the wavelength is the size of a slit or greater. When the wavelength is small, then diffraction effects are difficult to observe.
- In 1927 Clinton Davisson and Lester Germer established the wavelike behaviour of electrons when they performed a diffraction experiment. Not only did they observe diffraction effects, they also established that the wavelength of the electrons in the beam was consistent with Louis de Broglie's prediction.
- Both light and matter exhibit both particle-like and wavelike behaviours under the right circumstances.
- Double-slit experiments provide evidence for the dual nature (particle and wave) of both light and matter under conditions where single photons or material objects are used to illuminate the slits.
- Heisenberg's uncertainty principle asserts that it is not possible to simultaneously know both the position and the momentum of an object along a particular axis. The uncertainty in each variable,  $\Delta x$  and  $\Delta p_x$  respectively, is subject to the inequality  $\Delta x \times \Delta p_x \geq \frac{h}{4\pi}$  where  $h = 6.63 \times 10^{-34}$  J s.
- Heisenberg's uncertainty principle can be used to explain diffraction patterns produced by either beams of light or matter incident on a single slit.
- Classical laws of physics are not appropriate when investigating motion on very small scales, as the uncertainties associated with both position and momentum become sizeable in comparison to their values.

## Questions

### Electrons and light

1. What key features in the behaviour of electrons indicate that they are particles? In particular, how did experiments with cathode rays conclude that the rays were elementary particles?
2. Explain why the beam of electrons is deflected upwards in figure (b) on page 292.
3. In what way is the reddish glow of light from a dying fire different from the reddish glow from a neon discharge tube?
4. Light reaching Earth from the Sun is a continuous spectrum with many dark lines. These lines are called Fraunhofer lines. What is their origin?

5. Explain why spectral lines in the emission spectrum of an element correspond to absorption lines in an absorption spectrum for the same element.
6. A beam of red and green light appears yellow to a normal human. How could an experiment be devised to decide whether a beam of light that appeared yellow was in fact spectral yellow light or a mixture of red and green light?
7. Describe the main features of light emitted by the following objects. Use the descriptors continuous spectrum/discrete spectrum, temperature related/temperature independent, monochromatic, polychromatic, coherent/incoherent, and polarised/non-polarised.
  - (a) An incandescent light globe
  - (b) A candle
  - (c) The Sun
  - (d) A white hot bar of iron
  - (e) A fluorescent light tube
  - (f) An LED
  - (g) A laser
8. Explain why different LEDs can emit different colours.
9. An LED emits light of wavelength  $5.8 \times 10^{-7}$  m. Calculate the band gap of the semiconductor material in the LED.
10. The band gap in an LED is 1.8 eV. Calculate the average wavelength of light emitted by this LED.
11. Explain what is meant by the word 'coherence' when applied to photons of light.

### Matter as waves

12. Calculate the de Broglie wavelength of the following particles.
  - (a) A proton travelling at  $3.0 \times 10^7$  m s<sup>-1</sup>
  - (b) An electron accelerated by a voltage of 54 V, the voltage used by Davisson and Germer in their electron diffraction experiment
  - (c) A tennis ball ( $m = 0.20$  kg) moving with a speed 50 m s<sup>-1</sup>
13. In X-ray tubes the electric potential energy of electrons is transformed into the energy of X-ray photons. Consider a beam of electrons accelerated through 5 kV from rest, which rapidly decelerate when they collide with the anode of the tube.
  - (a) What is the kinetic energy of these electrons as they reach the anode, in joules?
  - (b) If the entire energy of each electron is transformed into the energy of a single photon, what is the wavelength of the resulting X-rays?
14. Explain what William L. Bragg meant when he said: 'On Mondays, Wednesdays and Fridays light behaves like waves, on Tuesdays, Thursdays and Saturdays like particles, and like nothing at all on Sundays'. Is this a good description of the behaviour of light?
15. A beam consists of electrons with speed  $2.5 \times 10^6$  m s<sup>-1</sup> inside an evacuated tube. The beam is directed towards a thin crystal of sodium chloride that can act as a diffraction grating. The spacing between atoms for this crystal is  $2.8 \times 10^{-10}$  m.
  - (a) Calculate the momentum and the de Broglie wavelength for electrons in the beam.
  - (b) By comparing the wavelength to the atomic spacing, discuss whether or not the electrons would diffract significantly.
16. Electrons may display wave properties and diffract when passed through narrow openings. In a particular experiment a scientist uses an electron gun to direct a beam of electrons towards a crystal. It is thought that the spacing between the atoms in the crystal is about  $5 \times 10^{-10}$  m. He adjusts the accelerating voltage of the electron gun to 3.0 kV.
  - (a) Find the energy of electrons in the beam in eV and in joule.
  - (b) Calculate the momentum and hence the de Broglie wavelength of the electrons.
  - (c) Determine whether or not the scientist should expect to observe significant diffraction effects.
  - (d) How should the scientist adjust the accelerating voltage make electrons diffract significantly when passing through the crystal?

He now decides to use photons to obtain the same diffraction pattern when passing a beam of photons through the same crystal.

  - (e) What wavelength and hence momentum photons should he use?
  - (f) What is the energy of these photons? Give your answer in joule and electron volt.
17. Calculate the speed of an electron that has the same de Broglie wavelength as a photon of red light whose frequency is  $4.5 \times 10^{14}$  Hz.
18. An electron and a proton are accelerated through the same potential difference.
  - (a) Which will have the greater de Broglie wavelength?
  - (b) Using a potential difference of 1000 V, calculate the de Broglie wavelength for both an electron and a proton.

The mass of a proton is  $1.67 \times 10^{-27}$  kg.
19. Electrons can be accelerated with a potential difference in an electron gun. In order to make a beam of electrons whose de Broglie wavelength is  $2.0 \times 10^{-10}$  m, what potential difference must be used?
20. Which has the shorter wavelength: a 10 eV electron or a 10 eV photon?

## Energy level transitions

**21.** There are two common ways of depicting the energy levels of an atom. In one method the ground state is taken to be zero energy, and in the other method the ionisation energy is taken to be zero. The first excited state of mercury atoms is known to be 4.9 eV above the ground state, the second excited state is 6.7 eV, the third excited state is 8.8 eV, and the ionisation energy is 10.4 eV above the ground state. Using the second method, where the ionisation energy is taken as 0 eV, give the energies of the ground state and the first 3 excited states. *Note:* Your values will be negative numbers, and a drawing of the energy level diagram will assist you.

**22.** Hydrogen is the name given to the atom consisting of the least number of particles — one proton and one electron.

- Explain what the word 'ground state' means when used to discuss atomic structure.
- Draw a diagram representing the first 5 energy levels (the ground state plus the first 4 excited states) in a hydrogen atom with the energy axis drawn to scale and each energy level given based on the ground state (taking the ground state as having zero energy). Use the electron volt as the energy unit. As a starting point, the ionisation energy of hydrogen is 13.6 eV, but you will need to find additional information via the internet or some other source.
- Conduct research to find out about the Balmer series, the name given to a group of lines that appears in the emission spectrum of hydrogen.

**23.** The light from a red light-emitting diode (LED) has a frequency of  $4.59 \times 10^{14}$  Hz. What is the energy change in electrons within atoms that produce this light?

**24.** Light of wavelength 420 nm is absorbed by gas consisting of helium atoms.

- Explain in terms of energy transfer to the atom why the light is absorbed.
- Calculate the increase in energy of an electron within a helium atom that has absorbed a photon of wavelength 420 nm.

**25.** Fill in the gaps in the following table.

Element	$\lambda$ (nm)	$f$ (Hz)	$E$ (J)	$E$ (eV)	$p$ (N s)
Red light			$3.1 \times 10^{-19}$		
Electron				1.96	
Blue light	405				
Electron	405				

**26.** The ground state and the first three excited states of hydrogen are shown in the diagram below. An emission spectrum of hydrogen gas shows many different spectral lines.

- Copy the diagram and label the ground state and first three excited states.
- Draw arrows to represent all possible six transitions that may occur when hydrogen atoms in states lower than the fourth excited state emit a photon of light.
- Calculate the energy of each of the possible six photons.
- Determine the wavelength of the photon having the least and greatest energy in your answer to part (c).

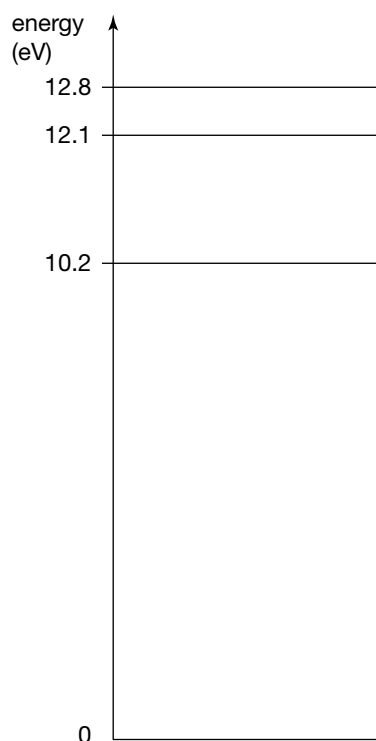

**27.** Explain why there are dark lines in an absorption spectrum of a gaseous sample. Why are those particular colours missing from the otherwise continuous spectrum of light passed through a gaseous sample?

**28.** When sodium chloride (common salt) is placed in a flame, the flame glows bright gold. The following diagram shows some of the energy levels of a sodium atom.

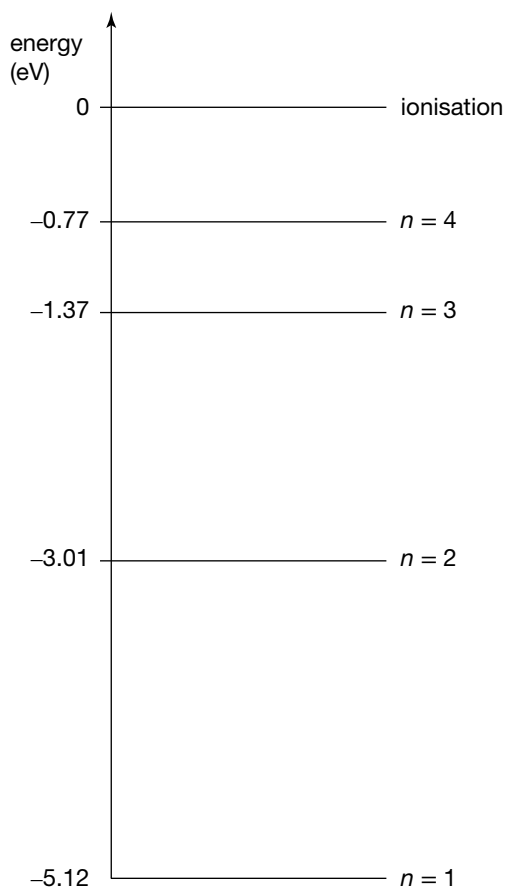

- On a copy of the diagram, label the ground state of the atom, and the first excited state.
- Draw arrows to represent the change in energy of atoms in the ground state that absorb energy during collisions with other particles in the flame.
- Calculate the wavelength of light emitted by these atoms as they return to the ground state in a single jump. Which energy change is responsible for the yellow glow?

- 29.** The figures on page 299 show the emission and room temperature absorption spectra of hydrogen. Most, but not all, of the emission spectrum is just the 'negative' of the absorption spectrum. The UV line at 0.0122 nm appears in both the emission spectrum and in the absorption spectrum, but the visible line at 656 nm appears only in the emission spectrum — why?

### Heisenberg's uncertainty principle

- Explain each term in the Heisenberg uncertainty inequality.
- An electron is confined to be inside an atom of diameter  $2.0 \times 10^{-10}$  m. Use this size to estimate the uncertainty in the momentum of this electron.

- It is known that electrons do not exist inside the nucleus of an atom.
  - Taking the size of a nucleus to be  $1 \times 10^{-15}$  m and using this size as the uncertainty in the position of an electron potentially positioned inside a nucleus, calculate the uncertainty in the momentum of this electron.
  - If electrons can have this amount of momentum due to uncertainty, calculate the kinetic energy that these electrons could have due to the uncertainty principle. Use the equation  $E_k = \frac{p^2}{2m}$ . Express your answer in joules and in electron volts.
  - On the basis of your answer to part (b) and experimental evidence regarding electron energies, explain why electrons do not occupy the nucleus.
- A student tells you that she is perfectly still with zero momentum. Use the uncertainty principle to explain why her position will have a relatively large uncertainty.
- Use the concept from question 33 to argue why achieving absolute zero kelvin is unobtainable.
- Why does a diffraction pattern spread out when the width of the single slit is reduced in size?
- Sketch the diffraction pattern that would be observed if an opening consisted of two slits perpendicular to each other with slit 1 twice the width of slit 2. Below is a diagram of the aperture.

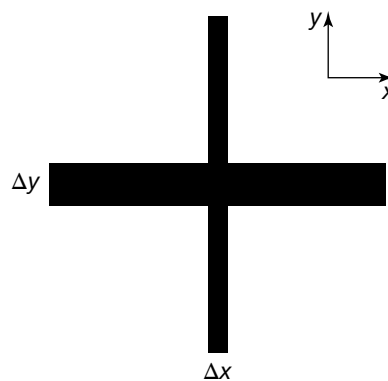

- Why is significant diffraction not observable when a person walks through a doorway into a classroom? Estimate the momentum of a person and the width of a doorway to illustrate this point by comparing the momentum of the person with the uncertainty associated with sideways momentum due to the person passing through the doorway.
- Why are the classical laws of physics insufficient to deal with motion at very small scales?

## KEY IDEAS

After completing this chapter, you should be able to:

- recognise and generate independent, dependent and controlled variables
- apply physics concepts to the topic of the investigation
- demonstrate the methods of scientific research and techniques of data collection with reference to their precision and reliability and the significance of uncertainty in the data
- conduct an investigation safely
- fully analyse the data, identifying patterns and relationships and acknowledging the limitations due to uncertainty in the data
- identify evidence that supports or refutes their expected findings or physics explanations
- describe the key findings of the investigation and their relationship to concepts studied
- use the conventions of scientific report writing and scientific poster presentation, including physics terminology and representations, symbols, equations and formulae, units of measurement, significant figures, standard abbreviations and the acknowledgment of references, if used.

As part of Unit 4, you will conduct a practical investigation on one area of one of these topics: electric and magnetic fields, gravitational fields, forces and energy of motion, electromagnetism, and the properties of waves and light.

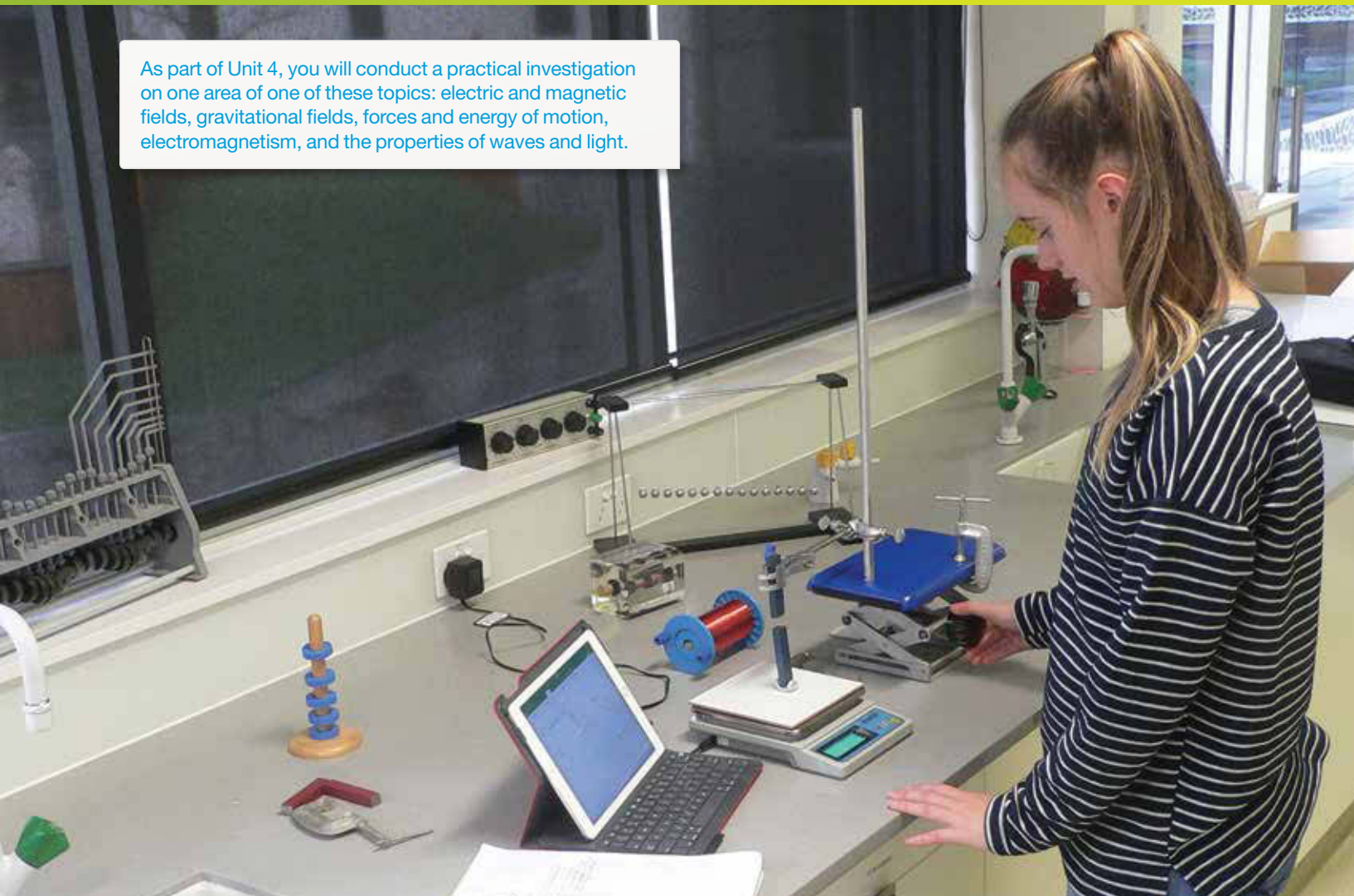

## What is the benefit to you?

As part of Unit 4, you will conduct a practical investigation on any aspect of the content in this book. This includes electric and magnetic fields, gravitational fields, forces and energy of motion, electromagnetism, and the properties of waves and light.

The practical investigation lets you follow your own interests. Enjoy creating solutions to questions that are important to you, managing your work and telling others about what you have done. Your study of Physics should help you to be more scientific.

Reflect on what it means to be 'scientific', and the characteristics of scientific ways of doing things compared to non-scientific ways. You will improve your ability to solve problems, use resources and communicate ideas. These attributes are useful in everyday life and highly valued in the workplace.

Being scientific means making use of observations, experiments and logical thinking to test ideas.

## What is involved?

Many of the experiments you have done as part of this course were designed with clear instructions and specific questions to answer. They are often designed to experimentally confirm a known relationship such as  $F = m \frac{4\pi^2 r}{T^2}$  or  $F = nBIl$ .

In this investigation, there is more responsibility on you to plan and carry out the task. It gives you the opportunity to show your skill and imagination in experimental design, commitment to a task and your communication ability in explaining your results.

The topic can be one of your choosing and you can work individually or with another student. It is a rare topic that requires three pairs of hands and eyes.

The investigation will require a significant amount of class time. Your teacher will set aside two to three weeks for the activity, so some planning and organisation on your part will be needed to achieve a personally satisfying outcome. The table below will assist with your planning.

Your teacher has some flexibility as to when to schedule this activity. It could be towards the end of Term 3, when you have been exposed to all the Areas of Study from which you can select a topic, or it could be earlier in the year as part of or after Unit 3, which is rich in possible topics.

## How does this investigation differ from the Unit 2 investigation?

Much of the process of undertaking the Unit 4 investigation is unchanged from the Unit 2 investigation, but the Unit 4 investigation is more substantial. It requires more class time, consideration of more aspects, and a deeper level of analysis. The assessment is also more significant.

For Unit 4 you will again investigate the effect of varying two independent variables, but this time both variables must be continuous. This increases the amount of data collection, and the opportunities for data analysis and identification of mathematical relationships between your dependent variables and both independent variables.

The investigation will also contribute to your study score for this subject. Your teacher's assessment of your investigation will make up 7% of your score. Each of the three Areas of Study in Unit 3 contributes 7%, while the other two Areas of Study in Unit 4 each contribute 6%, giving a total of 40% for your teacher's assessment of your work for the year. The end-of-year exam makes up the remaining 60%.

You will also present a summary of your investigation as a poster, preferably as an electronic poster, that is, one PowerPoint slide, as that will be an easier format to work with than an A1 sheet of paper.

It is also expected that the end-of-year exam will include questions on the student-designed practical investigation. Given that students across the state and in your class will be investigating a diverse range of topics, any questions would need to be of a generic nature, that is, they could be answered by any student regardless of the topic they investigated. Examples of such questions include:

- A student's procedure is described with some faults. You are asked to identify the faults and suggest alternatives.
- Data has been graphed and analysed, but with some errors in both the graphing and analysis. You are asked to correct the graph and recalculate some parameters from the graph.

The end of the chapter has some sample questions with more on JacPlus.

**TABLE 13.1** Investigation planning with sample schedule

Task	Due date
Your teacher spends some class time introducing the task, explaining what is expected of you, suggesting some possible topics or brainstorming other topics with the class. They will also outline the timeline and distribute a form for you to write down one or more topics that you would like to investigate.	About two weeks before formal experimentation begins
You return your list of possible topics for approval by your teacher, who then provides feedback, recommendations and finally approval.	A few days later
Submission of your detailed research proposal Your teacher may decide to make this a formal task, done under test conditions in class and assessed, but with feedback provided afterwards on aspects that might need to be addressed before you begin.	At the beginning of the week before your experiment begins
Your requested equipment is assembled by the teacher and lab technician.	By the end of the week before your experiment begins
Your investigation begins. First period: Set up your equipment, take some preliminary data, finetune your procedure, and troubleshoot any difficulties with the equipment and the taking of measurements Second period: Begin the cycle of measurements and data analysis. Progressively graph your results, evaluate trends and adjust your procedure.	Week 1
Continue the cycle of measurements and data analysis, leading to a review of progress and further more detailed measurements. Move on to investigating the second continuous independent variable.	Week 2
Finalise the investigation of the second variable. Begin preparing your overview of the investigation: summarising your procedure, what you have found out, what difficulties you had and how you addressed them.	Week 3
Finalise writing the sections of your report and paste them into a poster template. Submit your log book and poster.	Beginning of week 4

## Selecting a topic

Coming up with a topic is not something that happens straight away. You need to take some time to consider it. You want to investigate a topic that interests you, that provides opportunity for some challenge, yet can be done in the time available and with the resources available within the school.

The topic of your investigation can come from any of the content you are studying this year, so as you and your teacher are going through the course, you should be recording for future reference any possible topics that come to mind.

When your teacher formally introduces the task, you may wish to get together with some of your classmates and brainstorm a batch of topics. This can be an effective way to identify possible topics.

- Form a group of three to five and appoint a leader.
- Draw a grid on a large sheet of paper with headings across the top such as: Hobbies and interests, Sports, Science in the news, Investigations you did in previous years, and Course topics. Down the side have types of investigations such as: Investigating the operation of a device or technology, Solving a technological problem, Investigating a physical phenomenon.
- Pick a box from the grid and brainstorm some topics for that box, then move onto another one.
- If other groups have done the same task, combine your entries with theirs.

Hints for brainstorming:

- Concentrate on quantity, not quality. Get down as many ideas as you can, as fast as you can. Resist the temptation to evaluate as you go — do that later.
- Be prepared to be outlandish. Humour is creative. Ideas that are preposterous might trigger ideas that are not.

Practical investigations have been a popular feature of physics courses in many countries for several decades, so there are thousands of possible topics if you search around. Some are listed below, and a document that contains weblinks and many more additional topics can be found in your eBookPLUS. You should check through these lists and see what sparks your interest because choosing a topic that intrigues you will ensure a high level of commitment and a sense of pride in the finished work. Avoid seemingly sophisticated topics; everyday topics are not only readily accessible and initially straightforward to investigate, but they often have hidden subtleties.

## Turning the topic into a good question

Turning the topic into a question focuses your mind on what you want to find out. The question needs to be:

- one that experimenting can answer
- one worth investigating to you
- practicable, given your knowledge, time and the school resources
- asked in a way that indicates what you will do.

## Submitting a research proposal

Once your teacher has approved your topic, the real work begins. On the next page is a typical proposal sheet that you could be asked to complete.

## Keep a log

Use a separate, bound exercise book. Use it for thinking, calculating, drawing, leaving messages and preparing your report. You can use it to record your data if you don't want to use a computer. You can use the logbook to show your teacher how your work is progressing. Your logbook will also be assessed by your teacher.

Your logbook can include:

- your initial ideas
- notes from brainstorming
- notes from background reading
- equipment set up and plan
- your observations, measurements, data analysis and graphs
- difficulties you experience.



**Practical investigation proposal**

Name:	Jill
Partner's name: <i>(optional)</i>	Jac
Title of your investigation:	The efficiency of a DC motor
Briefly describe its purpose: <i>(A brief sentence, but needs to be precise)</i>	To investigate how efficiently a DC motor converts electrical energy into gravitational potential energy by raising a mass
Write down three starting questions you want to answer. <i>(These are to help focus your planning.)</i>	What is the most efficient voltage for a given mass? How does this voltage vary with the mass? For a given voltage is there a mass the motor cannot lift? Is the mass raised at a constant speed?
List independent variables, indicating which are continuous and which are discrete, as well as dependent variables. <i>(Enables your teacher to see if you have thought of all the obvious variables.)</i>	Independent: voltage supplied to the DC motor, the mass being raised, the diameter of the spindle about which the string from the mass is wrapped, the type of DC motor (discrete) Dependent: The current drawn by the DC motor, energy supplied to the DC motor, the time for the mass to travel a measured distance, gain in gravitational potential energy
List the Physics concepts and relationships that you expect to use in your investigation. <i>(To give your teacher an indication of the extent of your understanding of the topic)</i>	Electric energy consumption, $W = VIt$ Gain in gravitational potential energy, $GPE = mg\Delta h$  $\text{Efficiency} = \frac{mg\Delta h}{VIt}$
List the equipment and measuring instruments that you plan to use. <i>(For your teacher to see whether you have the right tools for the task.)</i>	DC motor with spindle on the shaft Masses — either slotted masses and/or plasticine Light, thin string, possibly with a small card of known length attached near the bottom to trigger a photo gate Variable power supply, voltmeter and ammeter, switch Ruler and balance Timer, preferably electronic, e.g. a photo gate
Sketch your experimental set up. <i>(This will make your first day of investigating smoother, and your teacher may be able to suggest refinements.)</i>	
List the steps in your experimental design. <i>(This is an important stage in your planning and it will enable your teacher to see if there is anything you have forgotten.)</i>	<ol style="list-style-type: none"> <li>1. Connect the circuit and attach a mass to the string. Set to a low voltage and turn on the power supply. Adjust arrangement of equipment and voltage and mass values to get a safe set-up that is capable of producing data without damaging the motor.</li> <li>2. Adjust timer, card and photo gate set-up to produce consistent readings.</li> <li>3. Set the mass at a known value, set the voltage at a low value, and measure the current and time at least five times.</li> <li>4. Increase the voltage settings in increments of 1 V and repeat the measurements. Use a voltage divider circuit if in-between voltage values would be useful.</li> <li>5. Increase the mass progressively and repeat steps 3 and 4 each time.</li> <li>6. Check for possible intermediate mass values to identify maximum efficiency.</li> </ol>
Any special requests <i>(E.g. equipment may need to be left set up between classes, or access at lunchtime or after school may be needed.)</i>	Not really.

If you are using a computer or a school server as your log book, you should ensure that the software enables your entries to be reliably date stamped. This authenticates the work as your own.

## Variables

Variables are the physical quantities that you measure. For some variables you will set the value at the start of each experiment; others will be determined by your experiment; and sometimes there may be variables that you calculate using your measurements.

- *Independent variables* are the ones whose value you determine. You would not investigate all of these; you should choose just two that interest you. However, your report should mention them all to show your deep understanding of the problem you are investigating. The ones you don't investigate will have constant values during your experiment, so they could be called *fixed* or *controlled variables*. There are two types of independent variables:
  - *Continuous variables* are ones that can take any numerical value, such as the release height of a parachute. This means they can be graphed using  $x$ - and  $y$ -axes. A graph can reveal a mathematical relationship between two quantities.
  - *Discrete variables* are ones that allow for different types, for example different-shaped parachutes. These can only be presented as a column graph, which enables comparison but does not reveal a mathematical relationship.
- *Dependent variables* are the ones that come from your experiment. Their values are determined by the independent variables. Again, you would not analyse all of them. Just one will normally suffice.

### Revision question 13.1

In this investigation, two independent continuous variables are needed.

Jill and Jac plan to investigate the sweet spot of a cricket bat. The variables they are considering are: (i) the position on the bat where the ball hits, (ii) the speed of the ball at impact, (iii) the mass of the bat, (iv) the profile of the bat (e.g. a length of timber as a model for the bat versus a real bat), (v) the mass distribution of the bat (e.g. whether the bat is hollowed out or not), (vi) whether the handle is fixed but the bat is able to swing or whether the handle is free to move. Classify these independent variables into the two categories: continuous and discrete.

### Revision question 13.2

List as many dependent variables as you can think of that Jac and Jill might consider for their investigation, including ones that can be calculated from others.

The end of this chapter has some more questions on identifying variables.

## Selecting your measuring instruments

Your school will have a range of measuring instruments. They will vary in precision and ease of use.

You won't always need to use the most accurate instrument. A simple instrument that allows for quick measurements will be enough more often than not. Sometimes a simple stopwatch is just as good as an electronic timer, and a beam balance may compare well to a very accurate top loading balance.

Some instruments that you might consider are listed below based on what they measure.

**Mass**

- Slotted masses of known mass. Simple to use; accurate; comes only in multiples of a set weight, e.g. 50 g.
- Beam balance. Accurate with a large range of values; can be time consuming to measure several masses.



- Spring balance. Quick to use; covers a large range of masses; not very accurate.
- Top loading balance. Very accurate; very good for small masses; simple to use. With equipment set up above the balance, it can be used to measure small variations in attractive and repulsive forces such as magnetic force, electric force and surface tension. If the balance sits on a laboratory jack, force against distance can be easily measured.





### eBookplus

#### eLesson

Using Vernier callipers

eles-2558

### Length

- Metre ruler. Accurate; good for a range of distances; can be read to about 0.5 mm.
- Laboratory jack. For fine adjustment of height.
- Vernier calliper. For precision measurement of short distances; takes some time to learn how to use.
- Micrometer. For precision measurement of thicknesses; takes some time to learn how to use and can be easily damaged.



### Time

- Stopwatch. Simple to use; accurate down to your response time; not reliable for short time intervals.
- Electronic timer. Requires some instruction; very accurate; best suited for short time intervals; can be used with electrical contacts and photogates.

### Motion

- Ticker timer. Simple to use; limited in accuracy; best with objects moving over a short distance; can be time consuming to analyse.
- Air track. Very accurate, particularly if used with photogates; very effective in studying collisions; takes some time to set up, but data collection is very efficient once done.



- Ultrasound motion detector. Quite accurate; useful with real motions; lots of data which means data analysis in Excel can be time consuming.
- Video with analysis software. Quite accurate; requires some setting up; data obtained from software; data analysis in Excel can be time consuming. Free video motion analysis software are Tracker and PhysMo. Digital cameras with high-speed video are useful for measurement of short, fast events.

### Electrical

- Meters: Voltmeters, ammeters, galvanometers. Easy to set up, but care is needed to ensure the meter is wired into the circuit correctly, otherwise the meter can be damaged; large range of values; usually analogue displays.
- Multimeters. Easy to set up; more tolerant of incorrect use, but can be damaged if incorrectly connected to a high current; large range of values; usually digital displays.

### Specialist equipment

- Cathode-ray oscilloscope (CRO). Even though the CRO is basically a visual voltmeter, it is a versatile instrument. It can measure both constant and varying voltages. The sweep of the trace across the screen can be used to measure time intervals of the order of millionths of a second. Many transducers, such as microphones, produce a voltage that can be displayed on the screen, either for analysis or measurement of very short time intervals. There are also computer versions of CROs that can be freely downloaded.
- Data loggers. There are sensors now available for most physical quantities, such as temperature, pressure, light intensity, motion, force, voltage, current, magnetic field, ionising radiation. The recording of data by these sensors for later analysis greatly facilitates practical investigations.
- Apps. There are increasing numbers of apps that perform measurement functions. The accuracy of each needs to be confirmed before being used in a formal investigation, but it is an area worth exploring. Some sources include Physics Toolbox and Sensor Kinetics.

## Making the most of a measurement

### Limits to precision and uncertainty

Every instrument has a limit to how precisely it measures. The scale or digital display imposes a constraint on how many digits you can record. The scale or display also reveals the tolerance of the measurement.



A metre ruler has lines to mark each millimetre, but there is space between these lines. You could measure a length to the nearest millimetre, but because of the space between the lines, if you look carefully, you can measure to a higher precision. You can measure to the nearest 0.5 mm.

The best estimate for the length of the red line in the figure at left is 2.35 cm. The actual length is closer to 2.35 cm than it is to either 2.30 cm or 2.40 cm. The measurement of 2.35 cm says the actual length is somewhere between 2.325 cm and 2.375 cm.

The way to write this is:

$$\text{The length of the red line} = 2.35 \pm 0.025 \text{ cm}$$

The 0.025 represents the tolerance or uncertainty in the measurement.

In this case, with well-spaced millimetre lines, the tolerance is  $\frac{1}{4}$  of the smallest division. For a dense scale where measurement lines are close together, the tolerance would be  $\frac{1}{2}$  of the smallest division.

The reading on a digital scale is 8.94 grams. This means the mass is not 8.93 g nor 8.95 g. The actual mass is somewhere between 8.935 and 8.945 grams. The way to write this is:

$$\text{The mass} = 8.94 \pm 0.005 \text{ g.}$$



### Sample problem 13.1

Record the reading on the scales below, including the tolerance.



**Solution:** The scale shows 0.250 g, so the actual weight may be between 0.2495 g and 0.2505 g. The mass is written as  $0.250 \pm 0.0005$  g.

### Revision question 13.3

(a) Determine the length of each line in the diagram below, showing the tolerance in each case.

(i)

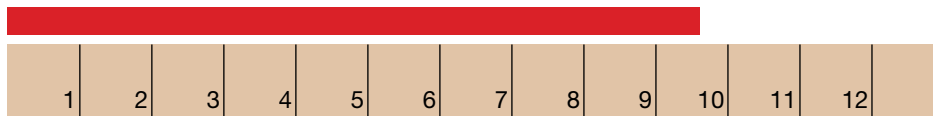

(ii)

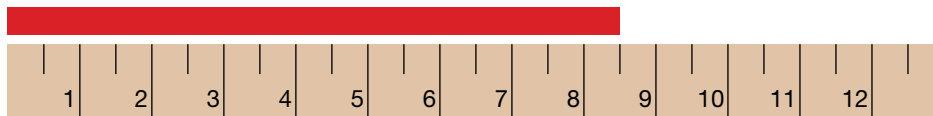

(iii)

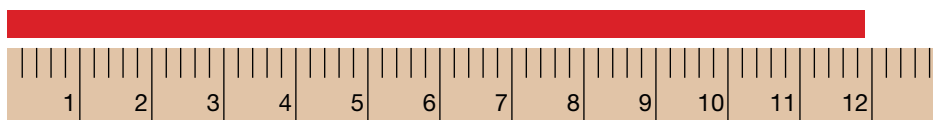

(b) Record the reading on the scales at left, including the tolerance.



#### eBook plus

##### eLessons

Determining significant figures

eles-2559

Calculating error

eles-2560

## Repeated measurements

Measurements of independent variables are usually precise and careful, so one measurement should be enough. However, measurements of the dependent variables are often prone to some variation.

Whether the variation is caused by the human reaction time when using a stopwatch, judging the rebound height of a basketball or in the case of the parachute, the unpredictable way the canopy will open each time, each reading may be different. So it is sensible to take several readings to obtain an average. You would expect that at least three measurements would be needed, and possibly five, but more than five is generally unnecessary.

In some instances the variation between different readings will exceed the precision of the instrument. To determine which value you plot, you would use the average as well as the spread of the readings. For example, if your partner dropped the basketball from a height of 80.0 cm, and you judged the rebound height of the ball for five trials as: 68 cm, 69.5 cm, 68.5 cm, 68.5 cm and 69.5 cm. The average is 68.8 cm, which you would round to the nearest 0.5 cm because of the difficulty of judging a moving ball, giving an average of 69 cm. The full range of your measurements is from 68 cm to 69.5 cm, so your uncertainty would need to be 1 cm to cover the full range. This set of measurements would then be written as  $69 \pm 1$  cm.

This format is useful in two ways: graphing and calculating.

When you graph your results, the number you will plot is 69 cm. To represent the ' $\pm 1$  cm', you can draw a line through the point, up 1 cm and down 1 cm, with a short line across the top and bottom of the line to make the ends evident.

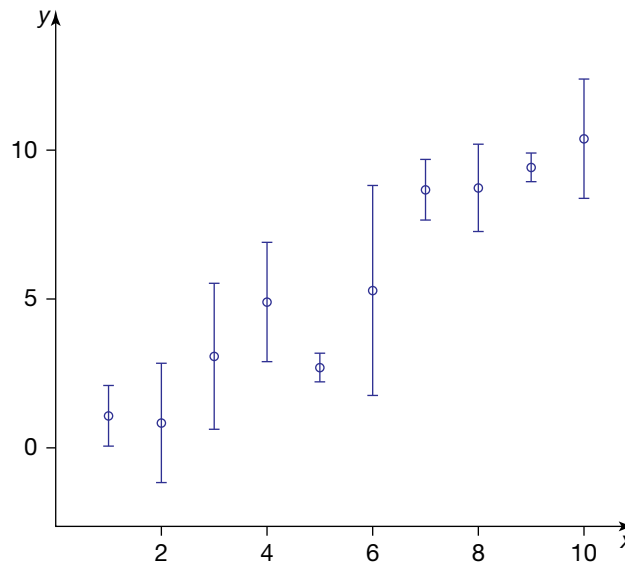

Example of error bars

Rather than graphing rebound height against drop height, it is more revealing of the physics of the situation to calculate and graph the ratio of the rebound height to drop height against drop height. The ratio is a measure of how much of the original gravitational potential energy is restored.

In this case the ratio would be  $\frac{69}{80.0} = 0.8625$ , but how many digits are we entitled to use and how big should the error bar be? The first question is reasonably straightforward. The number of digits in your answer should equal the smallest number of digits in the data you used in the calculation. In this instance the average height has two digits, so the answer would be written as 0.86. You are not justified in including more digits because you don't know the original data accurately enough.

Working out the size of an error bar takes more effort. If the two pieces of data are  $69 \pm 1$  cm and  $80.0 \pm 0.3$  cm, we can just add the uncertainties to get  $\pm 1.3$  cm, but that doesn't make sense when the calculated value is 0.86. Dividing the uncertainties would produce another unusual result.

The method used is to first express the uncertainty for each data value as a percentage. For example:

$$\text{Percentage error of } 69 \pm 1 \text{ cm} = \left( \frac{1}{69} \right) \times 100 = 1.4\%$$

$$\text{Percentage error of } 80.0 \pm 0.3 \text{ cm} = \left( \frac{0.3}{80} \right) \times 100 = 0.4\%$$

Now add the two percentage errors together:

$$\text{Total percentage error} = 1.4\% + 0.4\% = 1.8\%$$

Next use this total percentage error to find the error in the calculated answer.

$$\text{Error} = 0.86 \times 1.8\% = 0.016, \text{ which would be rounded to one digit as } 0.02.$$

The full calculated answer would now be  $0.86 \pm 0.02$ .

The percentage errors are added together regardless of whether the data values are divided, multiplied, added or subtracted. For example:

- Calculating speed using  $v = \frac{\Delta x}{\Delta t}$ , the percentage errors of displacement and time would be added together.
- Calculating momentum using  $p = mv$ , the percentage errors of mass and velocity would be added together.
- Calculating the change in momentum using  $\Delta p = p_{\text{final}} - p_{\text{initial}}$ , the actual uncertainties of each are added together.

## Finding patterns

Graphs are an effective way of summarising your data and looking for a physical relationship between the quantities you are investigating.

To present your data clearly, your graph should have the following features:

- Each axis labelled with the physical quantity it represents. It is convention to put the independent variable on the  $x$ -axis and the dependent variable on the  $y$ -axis. You want to find out how 'y' depends on 'x'. So, you might graph terminal velocity on the  $y$ -axis and mass on the  $x$ -axis.
- A scale with the units displayed.
- Include the origin, the zero value for the variables, on both axes. Sometimes the origin is a data point, even though you did not technically measure it. For example, if the drop height is zero, the rebound height would also be zero, and so the origin is a data point, but the energy lost cannot be determined and is not a data point. The inclusion of the origin on the axes makes any relationship more apparent. Truncating the values on either the  $y$ - or  $x$ -axis exaggerates the variation in the data, and may disguise any relationship between the variables.
- An error bar for each data point. Sometimes, given your scale, the error bars will be too small to be seen and so would not be worth including. If you are using Excel to generate your graphs, be careful when using the error bar facility. Correct usage is described below.

Graph showing a line of best fit

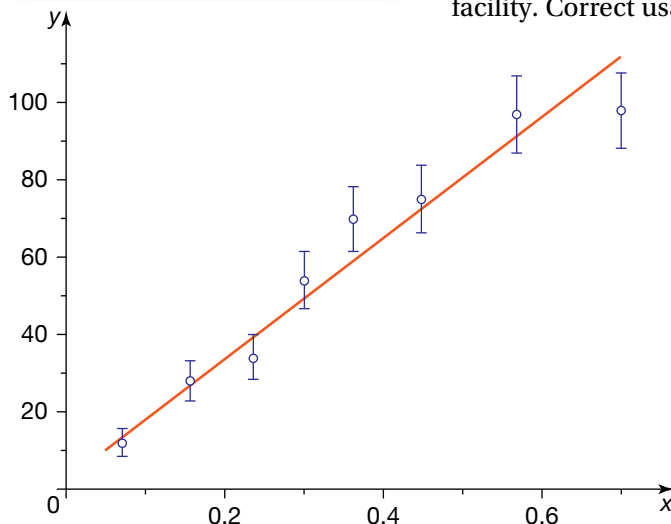

### Drawing a line of best fit

A line of best fit summarises your graph. The line can be used to find the gradient of your graph and also a  $y$ -intercept.

The line of best fit doesn't need to pass through each data point, although you should try to draw the line through each error bar if possible, but you may not be able to go through all of them. As a general rule, try to have as many data points above your line as you have below. Don't assume your line must pass through the origin.

Of course, not all graphs can be summarised by a straight line. A gentle curve may be more appropriate, which can be analysed further.



## Using Microsoft Excel

The Excel spreadsheet is a very useful tool to the experimenter. It can:

- store your measurements. Make sure you save your data every few minutes and do a backup every day.
- calculate any derived physical quantities, such as speed and acceleration of a parachute or the percentage of energy lost by a bouncing ball. The 'Fill down' command is a time saver.
- be a powerful graphing tool, but it must be used wisely. Because you are looking for a relationship between the variables, you must choose 'X Y (Scatter)' as your type of graph. This has the key scientific features of a proper scale and the presence of the origin. It is also preferable to choose a graph of unconnected data points as your sub-type. You don't want a line, straight or curved, going from data point to data point; some of your data points may be a touch out. A better choice is a 'line of best fit', which Excel can do for you.
- generate a line of best fit. If you right-click on any data point, a window pops up with the option 'Add Trendline'. This is the Excel command to create a line of best fit. Once selected, you have several choices. If your graph looks like a straight line, choose 'Linear'. If the graph looks like a curve passing through the origin, choose 'Power'. Students often think any curve is exponential, but unless the phenomenon involves growth or decay, it is very unlikely that a graph from a physics experiment would generate an exponential graph.
- create error bars. Excel can add in errors bars, but this is best avoided in most instances. It is likely that the size of your error bars will vary from data point to data point. Excel can't handle that. It assigns a fixed-size error bar to each data point. Error bars can be added by clicking on any part of the chart and going to the 'Layout' tab.

*Note:* These instructions may vary depending on the version of Excel you are using.

*Note:* In the 'Add Trendline' window, you can select to display the equation of the line of best fit on your graph. Care needs to be shown with numbers in the equation. The numbers of digits may not be justified by your data.

## Other aspects of scientific measurement

For your investigation, the aspects of scientific measurement that are most important are the ones discussed earlier: precision and uncertainty.

*Precision* means recording a measurement to the greatest detail possible for that measuring instrument. The word 'precision' is being used in the same sense as a 'precision tool'.

*Uncertainty* is acknowledging that no matter how precise an instrument might be there is a limit to that precision. The uncertainty is a range within which a measurement lies. An error bar is a way of representing that uncertainty graphically.

Aspects of scientific measurement that are not likely to be relevant to your investigation are qualities such as accuracy, validity and reliability.

*Accuracy:* If an archer is accurate, their arrows hit close to the target. If you are conducting an experiment to measure the acceleration due to gravity, which has a known value, your accuracy as an experimenter can be determined. However, in your investigation, you are keen to understanding the physics of the situation by identifying relationships between the variable, rather than determining the value of a quantity that you can just as well look up in a textbook.

*Validity* applies more to Biology and Psychology, where precise measurement is more difficult and there is the risk of bias on the part of the researcher.

In Physics and Chemistry, the variables are quantifiable and physically measurable. If your experimental method clearly relates to the purpose of the investigation and you take care to be precise in your measurements and thorough in your analysis, your results should be valid and meaningful.

*Reliability* refers to whether another researcher could repeat your investigation by following your method and obtain similar results. Obviously this cannot be determined by you or your teacher. However, the clarity and detail with which your experimental method is described will give the reader confidence that your investigation is reproducible, which is the key to scientific success.

## Handling difficulties

There will be times when:

- your results show no pattern
- your results aren't what you expected
- the equipment doesn't work
- you don't know what to do next
- you don't understand the references you have been reading.

How you handle such problems is important.

- Go back to basics. Check your logic, understanding and planning. Clarify the issue. Draw diagrams and concept maps if they help. Look for options. Go to a textbook.
- Talk to other students or members of your family. Sometimes just talking through a situation can help you see a solution.
- Seek help from your teacher.

Record in your logbook how you tackled the problem, what solution you found and where you got it from. This is good science and good management.

## Safety

Part of the enjoyment of a practical investigation is that the topic may be unconventional or use an innovative method. Such situations, however, can present some risk, so special care needs to be taken to ensure yourself and others are safe.

Some simple rules to follow are:

- Do the investigation as outlined in your approved plan. Don't vary your plan without approval from your teacher.
- Don't do experimental work unsupervised unless you have prior approval from your teacher.
- Investigations can take up more space than usual experiments, so be sensitive to the needs of other students in the classroom.
- When first setting up electrical experiments, ask your teacher to check the circuit.
- Don't interfere with the equipment set-up of others.

## Presenting your work for assessment

It is likely that there will be three components that contribute to the assessment of your investigation:

1. your initial research proposal
2. your logbook
3. your poster.

Your initial research proposal will have already been submitted and assessed. The poster will be only a summary of your investigation, the overall structure and the highlights; it is unlikely to be able to fit all your graphs, data analysis

and consideration of uncertainties. Your logbook will be an essential complement to the poster for your teacher to get a full idea of what you have accomplished. It is therefore important that supplementary material is included and is easy to find.

The poster should have an obvious and logical structure. There is no one prescriptive format, but it should include the elements listed in table 13.2.

**TABLE 13.2** Aspects of a written report

Section	Description
Title	A precise and complete description of what you investigated
Physics concepts and relationships	A short paragraph explaining the relevant concepts and relationships and how they apply to this investigation
Aim or purpose	Why are you doing this investigation? What do you hope to find?
Procedure	This is a major section. It describes what you measured, your selection of equipment and measuring instruments, and your step-by-step method. Include diagrams and photos. Refer to how you controlled variables; achieved the desired accuracy; and overcame, avoided or anticipated difficulties.
Observations and measurements	Include your data and graphs. If there is too much data, then refer to your logbook for the full set. Show how calculations were done using actual data. Also include illustrations of how uncertainties were calculated.
Analysis of results	How does your data support your initial intentions? How much is your analysis limited by uncertainties? Identify strengths and weaknesses in the investigation, indicating how you would do it differently if you repeated it, and what your next steps in the investigation would be if you had more time.
Conclusion	A short summary related to the initial purpose, summarising the meaning of your results

## Presenting your work as a digital poster

The logbook would be read in depth by your teacher, who will often spend more than 20 minutes going through it in detail. A poster has a different intent and a different audience. The structure of your investigation should be apparent and give the viewer a good sense of the investigation within several minutes' perusal.

A poster should address the sections outlined in table 13.2 without going into too much detail. For example, you would display only a subset of the data to convey your findings and accuracy. Similarly, not all your graphs need appear.

PowerPoint templates can assist with designing posters and make it much easier than putting together a hard copy on a large sheet of card. Check out the weblinks in your eBookPLUS for templates as well as examples of science posters.

## Advice on assembling a poster

### Layout

- Set up a clearly visible structure for your poster.
- Include a photo, diagram or graphs in each section, if possible.
- Have a short title.

- Start with an engaging statement about the topic you investigated.
- Give a quick overview of your approach, with images of experimental set-up and equipment used. A flow chart is an effective way of conveying your procedure.
- Present results in graphical form with commentary; this will be the largest section of the poster.
- Discuss your results with perceptive comments.
- Decide on font size and line spacing to achieve the best impact for your poster.

### Language

- Restrict the text to 800–1000 words.
- Adopt a more personal tone in the writing; use the active voice.
- Avoid large blocks of text and long sentences.
- Don't plagiarise; if you must quote, then acknowledge your sources.
- Use sentence case; that is, no all upper case sentences and avoid italicised sentences.
- Use serif fonts, such as Times New Roman and Palatino.
- Use italics for emphasis, rather than underlining or bold.
- Check spelling and grammar as well as whether the correct word has been chosen, e.g. affect or effect, it's or its etc.

### Graphs

- Avoid grid lines on graphs, they complicate the picture.
- Ensure scales are readable.
- Use informative titles to support the communication message of the poster.

## Topics

Here are some sample topics to get you thinking.

- The sweet spot of a tennis racket
- Bat (or club) and ball impacts
- The changeover from sliding to rolling
- Flight of a shuttlecock
- Surface tension of a liquid
- Performance of a parachute
- Effect of spikes on running shoes
- The performance of a CD hovercraft
- The performance of a water-driven rocket
- The impact force on and the energy lost by bouncing ball
- Flight of a table tennis ball
- The energy delivered by a catapult
- Dry sand is soft, wet sand is hard, wetter sand is soft again: investigate
- Factors affecting the design of a good paddle wheel
- The physics of a bicep curl
- The thrust of a propeller (in air or in water)
- The drag on spheres in an airstream
- The motion of spheres in a viscous medium
- The effect of changing the size or shape of the wings of a glider
- The flight of a magnus glider
- Physics of the long jump
- Effect of the blocks on a sprint start
- Modelling the impact of the head with the dashboard in a car crash
- Doing the 'ollie' on a skateboard
- Electric force between charged plates
- Magnetic force between two magnets

### eBookplus

**Digital doc**  
Investigation topics  
doc-16176

- Strength of an electromagnet
- Interaction between two glider-mounted magnets
- Efficiency of a DC motor
- The performance of a homopolar motor
- Efficiency of a DC motor used as a generator
- Efficiency of a bicycle dynamo
- The performance of a homopolar generator
- Refractive index of a sugar solution
- Patterns in stressed materials between crossed polaroids
- Polarisation and optically active substances
- Does the resolution of the eye depend on the illumination?
- The resolution of a microscope
- Measuring the thickness of a soap film by interference

### Topics with catchy titles

**Rolling can:** A stoppered can is partially filled with water and is rolled down an incline. Investigate the motion.

**Rocking bottle:** Fill a bottle with some liquid. Lay it down on a horizontal surface and give it a push. The bottle may first move forward and then oscillate before it comes to rest. Investigate the bottle's motion.

**Water ski:** What is the minimum speed needed to pull an object attached to a rope over a water surface so that it does not sink? Investigate the relevant parameters.

**Bouncing ball:** If you drop a table tennis ball, it bounces. The nature of the collision changes if the ball contains liquid. Investigate how the nature of the collision depends on the amount of liquid inside the ball and other relevant parameters.

**Popping body:** A body is submerged in water. After release, it will pop out of the water. How does the height of the pop above the water surface depend on the various parameters?

**Ionic motor:** An electrolyte (an aqueous solution of a salt such as  $\text{CuSO}_4$  or  $\text{NaCl}$ ) in a shallow tray is made to rotate in the field of a permanent magnet. An electric field is applied from a battery in such a way that one electrode is in the form of a conducting ring immersed in the electrolyte. The other electrode is the tip of a wire placed vertically in the centre of the ring. Study the phenomenon and find possible relationships between the variables.

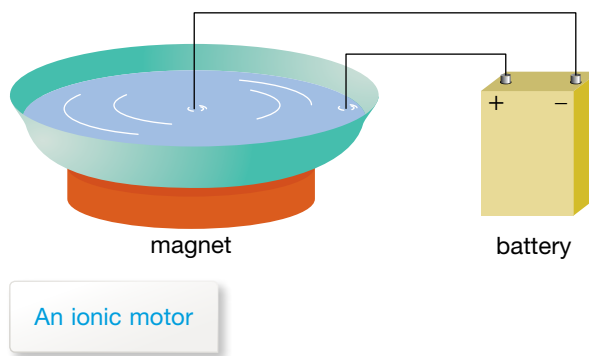

**Magnetic brakes:** When a strong magnet falls down through a non-ferrous tube, it experiences a retarding force. Investigate the phenomenon.

**Transformers:** The 'simple transformer law' relates output voltage to input voltage and turns ratio. Investigate the importance of frequency and other parameters in determining the non-ideal behaviour of transformers.

**Magnetohydrodynamics:** A shallow vessel contains a liquid. When an electric field and a magnetic field are applied, the liquid can start moving. Investigate this phenomenon.

**Vikings:** According to a legend, Vikings were able to navigate in an ocean even during overcast weather using tourmaline crystals. Investigate whether it is possible to navigate using a polarising material. What is the accuracy of the method?

**Photoelectric effect:** When light shines on some metals, electrons are ejected with a range of energies. How does the distribution of electron energies vary with the intensity of the light and the frequency?

## Brainstorming variables

Here are two topics with some variables identified. Complete the table for three others.

Topic	Independent variables		Dependent variables
	Continuous	Discrete	
Bouncing basketball	(i) Drop height (ii) Pressure of the ball	Surface ball lands on, ball type	Rebound height, impact time, energy loss, change in momentum, average force of impact
Efficiency of a DC motor	(i) Voltage drop across motor (ii) Mass being raised (iii) Diameter of spindle	Type of DC motor	Current through motor, time to travel fixed distance, power supplied, rate of gain of GPE, efficiency
(a) Performance of a parachute			
(b) Electric force between charged plates			
(c) The optical activity of sugar solutions			

# Chapter review

## Questions

1. Terry observes that when a droplet of water falls on a hot plate, it fizzes and shoots around the plate for some time. The droplet slowly gets smaller and finally disappears to nothing. Terry decides to investigate how long the droplet lasts, and how that might be affected by the temperature of the hot plate and the size of the droplet.

The equipment used was a hot plate, several droppers and a stop watch. The time was measured three times for each eye dropper and for six different temperature settings. The middle reading of the three readings was plotted. The graphs are shown below.

Drop time against eye dropper

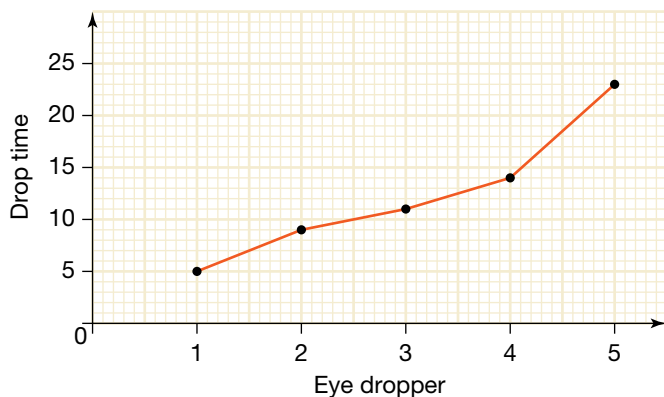

Drop time against temperature setting

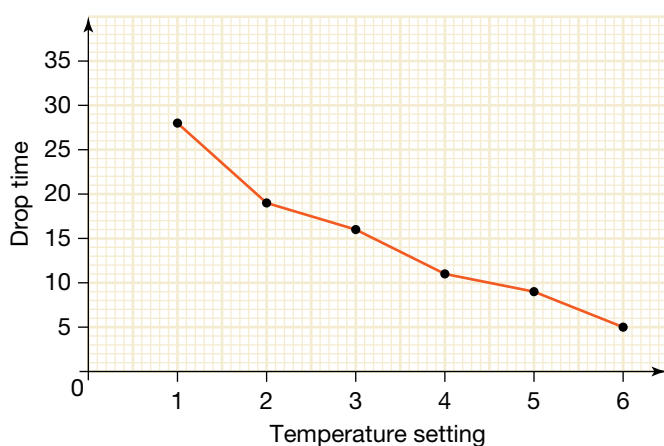

- (a) In one sentence, describe the purpose of the investigation.
- (b) List the variables in Terry's investigation. For each variable, indicate whether it is an independent or dependent variable, and for each independent variable, indicate whether it is a continuous variable or a discrete variable. Give a reason for each answer.
- (c) Suggest further data analysis. Include reasons.
- (d) Write a conclusion for this investigation.
- (e) A number of limitations may be identified in this investigation. Discuss these limitations and suggest some suitable improvements. Your discussion could address the following: selection of variables, experimental design, scientific method, data analysis, interpretation of results.
- (f) Suggest another independent variable.
- (g) Suggest a method for estimating the size of a water droplet.
2. Jackie decided to investigate an experiment found in the Amateur Scientist section of a very old edition of *Scientific American*. A large watch glass was placed on the cone of an upright loudspeaker. A small amount of water was added to the watch glass to a depth of a few mm. A signal generator was connected to the speaker, turned on and set at a high frequency. The water began to vibrate like a standing wave pattern. An eye dropper was then used to drop a water droplet onto the water surface. The droplet did not disappear into the water; instead, it moved around on the surface for some time before being absorbed. Write an experimental design for Jackie.





# Appendix 1 SKILL CHECKS

To help in developing our basic understanding of our physical world, it is perhaps reassuring to know that scientific conventions and mathematical principles help us to express the concepts of physics precisely.

This skill checks appendix provides information on some of the conventions used in physics and some of the mathematical skills used in solving problems. Areas covered are SI units, scientific notation, significant figures, finding the area under a graph, direct variation, using trigonometry, and using spreadsheets.

## SI units

So that scientists all over the world can communicate with each other effectively, it is important that they all use the same units to measure physical quantities. In 1960, the international authority on units agreed on a standardised system called the International System of Units. They are called SI units from the French '*Système International*'.

## Base units

SI units consist of seven defined base units and other derived units that are obtained by combining the base units.

**TABLE A1.1** The SI base units

Quantity	Unit	Symbol*
Length	metre	m
Mass	kilogram	kg
Time	second	s
Electric current	ampere	A
Temperature	kelvin	K
Luminous intensity	candela	cd
Amount of substance	mole	mol

\*Symbols that are named after people begin with a capital letter; note, however, that the full name of such a unit begins with a small letter.

Each base unit is defined by a standard that can be reproduced in laboratories throughout the world. The standards have changed over time to make them more accurate and reproducible. For example, in 1800, the standard metre was defined as one-ten-millionth of the distance from the Earth's equator to either pole. By 1900, it had changed to the distance between two notches on a bar of platinum-iridium alloy kept in Paris. In 1960, it was redefined as 1 650 763.73 wavelengths of the light emitted by the atoms of the gas krypton-86. In 1983, the definition was changed to what it is today — the distance travelled by light in a vacuum in  $\frac{1}{299792458}$  of a second.

The kilogram is defined by a standard mass of a platinum–iridium cylinder kept at the International Bureau of Weights and Measures in Paris since 1889.

The second is defined as the time taken for 9 192 631 770 vibrations of a caesium-133 atom.

## Derived units

Speed is an example of a quantity that is measured in derived SI units. The SI unit of speed is the metre per second, written as m/s or  $\text{m s}^{-1}$ . Table A1.2 shows some other commonly used derived SI units.

**TABLE A1.2** Some SI derived units commonly used in physics

Quantity	Unit	Symbol	Unit in terms of other units
Force	newton	N	$\text{kg m s}^{-2}$
Energy and work	joule	J	N m
Pressure	pascal	Pa	$\text{N m}^{-2}$
Power	watt	W	$\text{J s}^{-1}$
Electric charge	coulomb	C	A s
Voltage	volt	V	$\text{J C}^{-1}$
Resistance	ohm	$\Omega$	$\text{V A}^{-1}$
Radiation dose equivalent	sievert	Sv	$\text{J kg}^{-1}$

## Units and negative indices

Derived units are often expressed with negative indices. For example, the unit of speed is usually expressed as  $\text{m s}^{-1}$  rather than m/s. This is because:

$$\begin{aligned} 1 \text{ m/s} &= 1 \text{ m} \times \frac{1}{\text{s}} \\ &= 1 \text{ m} \times 1 \text{ s}^{-1} \\ &= 1 \text{ m s}^{-1}. \end{aligned}$$

Similarly, the unit of power, joule per second or J/s, is written as  $\text{J s}^{-1}$ .

The unit of pressure, newtons per square metre, or  $\text{N/m}^2$ , is written as  $\text{N m}^{-2}$  because  $\frac{1}{\text{m}^2} = \text{m}^{-2}$ .

## Metric prefixes

Some SI units are too large or small for measuring some quantities. For example, it is not practical to measure the thickness of a human hair in metres. It is also inappropriate to measure the distance from Melbourne to Perth in metres. The prefixes used in front of SI units allow you to use more appropriate units such as millimetres or kilometres.

### Revision question A1.1

- (a) Write down the full name of each of the units listed in the example column of table A1.3.
- (b) Express each of the following quantities in SI base units:
- |              |              |                        |
|--------------|--------------|------------------------|
| (i) 1500 mA  | (ii) 750 g   | (iii) 250 GW           |
| (iv) 0.52 km | (v) 600 nm   | (vi) 150 $\mu\text{s}$ |
| (vii) 5 cm   | (viii) 50 MV | (ix) 12 dm             |

- (c) Acceleration is defined as the rate of change of velocity. Velocity has the same SI unit as speed. What is the SI unit of acceleration?
- (d) The size of the gravitational force  $F$  on an object of mass  $m$  is given by the formula:  
 $F = mg$  where  $g$  is the size of the gravitational field strength.  
 (i) What is the SI unit of  $g$ ?  
 (ii) Express the SI unit of  $g$  in terms of base SI units only.

**TABLE A1.3** Commonly used metric prefixes

Prefix	Symbol	Factor by which unit is multiplied	Example
giga-	G	$10^9$	GW
mega-	M	$10^6$	MV
kilo-	k	$10^3$	kJ
deci-	d	$10^{-1}$	dm
centi-	c	$10^{-2}$	cm
milli-	m	$10^{-3}$	mA
micro-	$\mu$	$10^{-6}$	$\mu\text{g}$
nano-	n	$10^{-9}$	nm

## Scientific notation

Very large and very small quantities can be more conveniently expressed in scientific notation. In scientific notation, a quantity is expressed as a number between 1 and 10 multiplied by a power of 10. For example, the average distance between the Earth and the moon is 380 000 000 m. This is more conveniently expressed as  $3.8 \times 10^8$  m.

Using the power of 10 in scientific notation involves counting the number of places the decimal point in a number between 1 and 10 needs to be shifted to the right to obtain a multi-digit number. For example, the decimal point is shifted eight places to the right to get from 3.8 to 380 000 000. The latter number is therefore expressed as  $3.8 \times 10^8$ .

Scientific notation can also be used to express very small quantities conveniently and concisely. To give one example, the mass of a proton is

$$0.000\ 000\ 000\ 000\ 000\ 000\ 000\ 001\ 67\ \text{kg}$$

In case you don't feel like counting them, there are 26 zeros after the decimal point! In scientific notation, the mass of the proton can be expressed as  $1.67 \times 10^{-27}$  kg. The power of 10 is obtained by counting the number of places the decimal point in the number between 1 and 10 is shifted to the *left* to obtain the small number. The expression  $1.67 \times 10^{-27}$  means  $\frac{1.67}{10^{27}}$ .

In physics, scientific notation is generally used for numbers less than 0.01 and greater than 1000.

Quantities in scientific notation can be entered into your calculator using the EXP button. For example, to enter 425 000 000 000, you would enter  $4.25 \times 10^{11}$  as:

$$4.25\ \text{EXP}\ 11.$$

## Revision question A1.2

Express the following quantities in scientific notation:

- (a) the radius of the Earth, 637 000 m
- (b) the speed of light in a vacuum, 300 000 000 m s<sup>-1</sup>
- (c) the diameter of a typical atom, 0.000 000 000 3 m.

## Significant figures

There is a degree of uncertainty in any physical measurement. The uncertainty can be due to human error or to the limitations of the measuring instrument.

Before 1964, when the first electronic quartz timing system was used in international events, stopwatches (accurate to the nearest 0.1 s) were used to measure running times. There was no point in having more accurate hand-held stopwatches because the timing was dependent on human judgement and reaction time, a minimum of about 0.1 s. Any measurement of running time by a hand-held timing device has an uncertainty of at least 0.2 s. The International Amateur Athletic Federation now requires that world record times in running events are measured to the nearest one-hundredth of a second.

In 1960, the women's Olympic 100 m sprint was won by Wyomia Tyus (USA) in a time of 11.0 s. In 1984, the same event was won by Evelyn Ashford (USA) in a time of 10.97 s. The 1960 event was not timed electronically. The uncertainty of the measurement of time is indicated by the number of significant figures quoted.

The Wyomia Tyus time of 11.0 s has three significant figures. There would have been no point expressing the time as 11.00 because the nature of the timing device and human judgement and reaction time provide no degree of certainty in the second decimal place. The expression of the time as 11.0 s is consistent with the small degree of uncertainty in the last significant figure. To express the time as 11 s would suggest that the time was measured only to the nearest second.

The Evelyn Ashford time of 10.97 s has four significant figures. This is a reflection of the accuracy of the electronic timing devices and suggests that there could be a small degree of uncertainty in the last figure. The computerised timing systems used today can measure times to the nearest 0.001 s. The last figure quoted in world records therefore has no degree of uncertainty of measurement.

In most physical measurements, the last significant figure shows a small degree of uncertainty. For example, the length of an Olympic competition swimming pool is correctly expressed as 50.00 m. The last zero has a small degree of uncertainty. A pool can still be used for Olympic competition if it is up to 3 cm too long.

## Complicated by zeros

Two simple rules can be used to help you decide if zeros are significant.

- Zeros before the decimal point are significant if they are between non-zero digits. For example, all of the zeros in the numbers 4506, 27 034 and 602 007 are significant. The numbers therefore have four, five and six significant figures respectively. The zero in the number 0.56 is not significant.
- Zeros after the decimal point are significant if they follow a non-zero digit. For example, in the number 28.00, the two zeros are significant. The number has four significant figures. However, in the number 0.0028, the two zeros are not significant. They do not follow a non-zero digit and are present only to indicate the position of the decimal point. This number therefore has only two significant figures. The number 0.002 80 has three significant figures.

Sometimes, the number of significant figures in a measured quantity is not clear. For example, a length of 1500 m may have been measured to the nearest metre, the nearest 10 m or even the nearest 100 m. The two zeros are not between non-zero digits. The first rule given above, therefore, suggests that the length of 1500 m has only two significant figures. However, it could have two, three or four significant figures depending on how the length was measured. In order to avoid confusion, quantities such as this can be expressed in scientific notation. The length could then be expressed as  $1.500 \times 10^3$  m,  $1.50 \times 10^3$  m or  $1.5 \times 10^3$  m, giving an indication of the uncertainty.

When scientific notation appears clumsy, as it would for numbers such as 100 or 10, it is generally assumed that the zeros are significant.

## Calculating and significant figures

When quantities are multiplied or divided, the result should be expressed in the number of significant figures quoted in the least accurate quantity. For example, if you travelled a distance of 432 m in a car for 25 s, your average speed would be given by:

$$\begin{aligned} \text{average speed} &= \frac{\text{distance travelled}}{\text{time taken}} \\ &= \frac{432 \text{ m}}{25 \text{ s}} \\ &= 17.28 \text{ m s}^{-1}. \end{aligned}$$

The result should be rounded off to two significant figures to reflect the uncertainty in the data used to determine the distance and time, and should be expressed as  $17 \text{ m s}^{-1}$ .

When quantities are added or subtracted, the result should be expressed to the minimum number of decimal places used in the data. For example, if you travelled three consecutive distances of 63.5 m, 12.2517 m and 32.78 m, the total distance travelled would be given by:

$$\begin{array}{r} 63.5 \text{ m} \\ + 12.2517 \text{ m} \\ + 32.78 \text{ m} \\ \hline 108.5317 \text{ m} \end{array}$$

The result should be rounded off to one decimal place as the minimum number of decimal places used in the data is one in the distance of 63.5 m.

### Revision question A1.3

- (a) How many significant figures are quoted in each of the following quantities?
- 566.2 kJ
  - 0.000 32 m
  - 602.5 kg
  - 42.5300 s
  - $5.6 \times 10^3$  W
  - 0.008 40 V
- (b) Calculate each of the following quantities and express them to the appropriate number of significant figures:
- the area of a rectangular netball court that is 30.5 m long and 15.24 m wide
  - the perimeter of a soccer pitch that is measured to have a length of 96.3 m and a width of 72.42 m.
- (c) A Commonwealth Games athlete completes one lap of a circular track in a time of 46.52 s. The radius of the track is measured to be 64 m. What is the average speed of the athlete?

## Finding the area under a graph

There are several quantities related to forces and movement that need to be determined by calculating the area under a graph.

If the graph consists only of straight line sections, the task is simple. The area can be divided into triangles and rectangles. The areas of these shapes can be added together to determine the total area. The area under the graph in the figure below is found by adding areas P, Q, R, S and T.

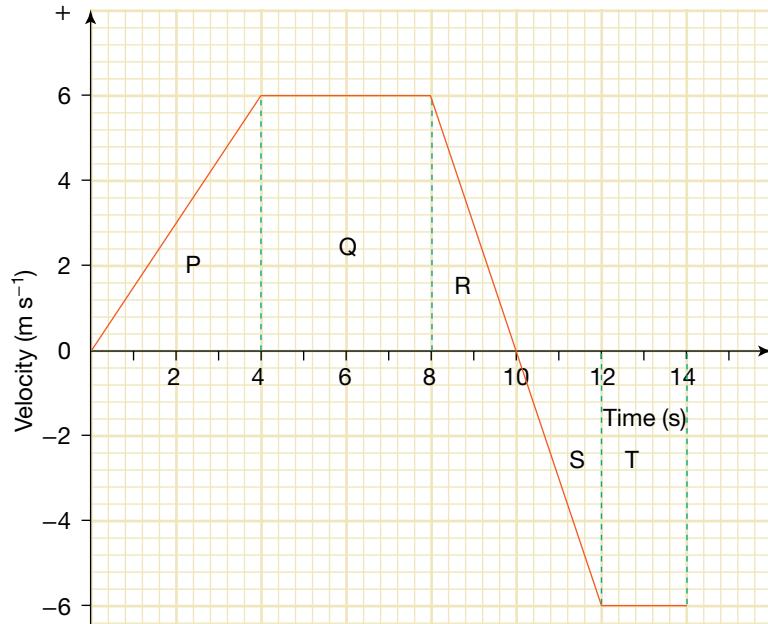

It is important to remember each area represents a quantity that has units. The unit of the area under the graph in the figure to the left is the metre because the quantities being multiplied to find the area are  $\text{m s}^{-1}$  and s.

$$\text{m s}^{-1} \times \text{s} = \text{m}$$

Areas under graphs can have direction. The area under the curve in the figure, for the interval from 10 s to 14 s, represents a negative quantity. During this interval, the object is moving in a 'reverse' direction and its displacement (relative to the origin) is decreasing.

The area under the graph in the figure is equal to:

Area P + Area Q + Area R + Area S + Area T

$$\begin{aligned} &= \frac{1}{2} \times 4 \text{ s} \times 6 \text{ m s}^{-1} + 4 \text{ s} \times 6 \text{ m s}^{-1} + \frac{1}{2} \times 2 \text{ s} \times 6 \text{ m s}^{-1} \\ &\quad + \frac{1}{2} \times 2 \text{ s} \times -6 \text{ m s}^{-1} + 2 \text{ s} \times -6 \text{ m s}^{-1} \\ &= 12 \text{ m} + 24 \text{ m} + 6 \text{ m} - 6 \text{ m} - 12 \text{ m} \\ &= 24 \text{ m}. \end{aligned}$$

This area is equal to the displacement of the object during the 14 s time interval.

The figure below shows how the net force on a car changes with time. In this instance, the area under the curve cannot be divided into regular shapes like triangles and rectangles. The area under this curve (which has units of N s) can be estimated by one of the following methods:

- counting the 'squares' between the curve and the horizontal axis. Find the area of each 'square' and multiply it by the number of squares. In the figure below, each small 'square' represents 25 N s. The number of squares under the graph is approximately 720. The area under the curve is thus estimated as 18 000 N s.
- drawing a regular shape that has the same area as the area under the curve. The area of the regular shape can be found by dividing it into triangles and rectangles. You need to make sure that the regular shape includes as much extra area (E) as it leaves out (F) (see the figure on next page).

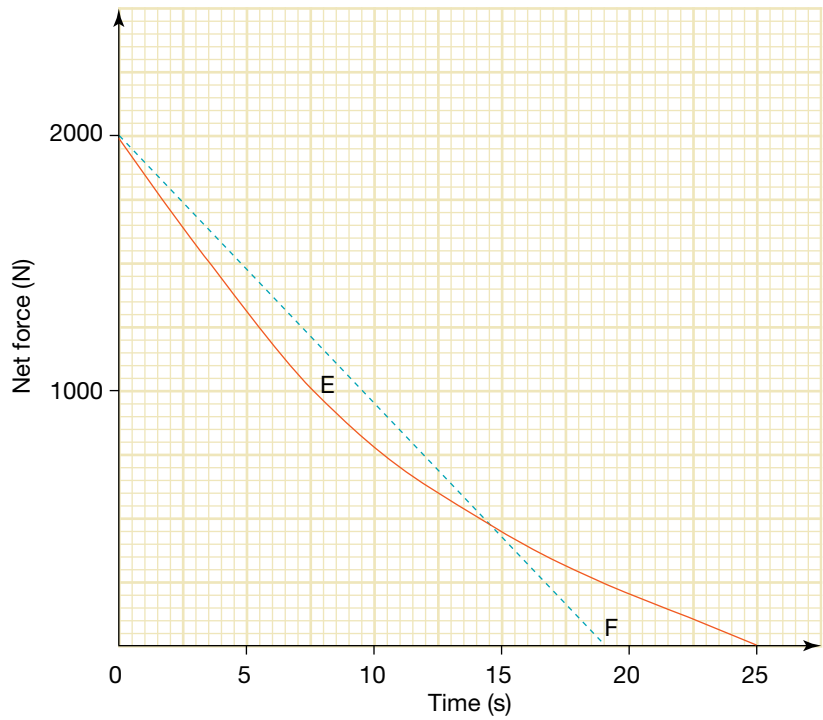

### Revision question A1.4

Determine the area under each of the following graphs.

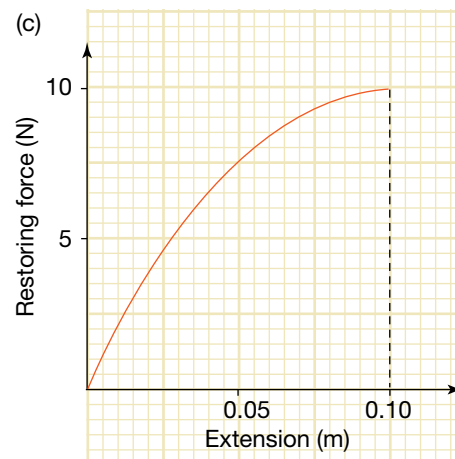
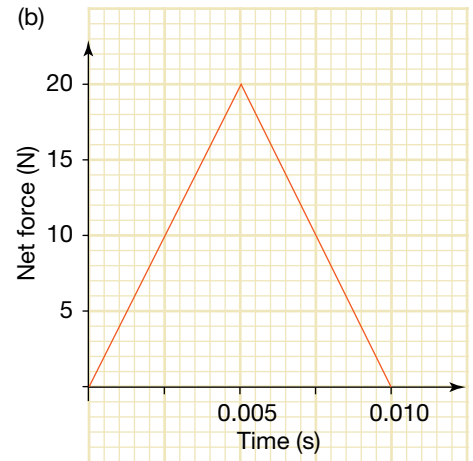
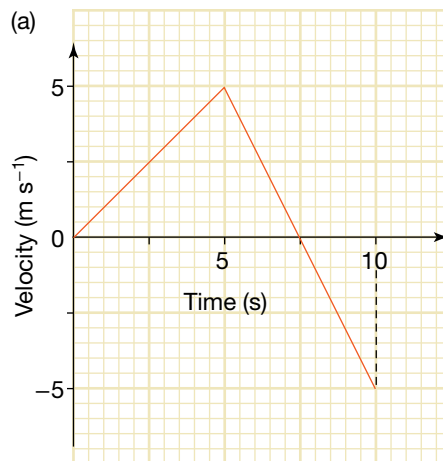

## Direct variation

If one quantity is directly proportional to another, a change in one results in a change in the other by the same proportion. Consider, for example, the relationship described by the equation  $y \propto x$ . This type of relationship is known as a direct variation. The relationship can be written as:

$$y = kx \text{ where } k \text{ is a constant of proportionality.}$$

Thus,

$$y_1 = kx_1$$

$$\text{and } y_2 = kx_2$$

$\Rightarrow$  When  $y \propto x$ ,

$$\frac{y_2}{y_1} = \frac{kx_2}{kx_1}$$

$$\Rightarrow \frac{y_2}{y_1} = \frac{x_2}{x_1}.$$

The ratio  $\frac{y}{x}$  is constant. That is, if  $x$  is doubled,  $y$  doubles. If  $x$  is tripled,  $y$  triples. If  $x$  is halved,  $y$  halves.

Many relationships in physics involve direct variation or direct proportion. For example, the power,  $P$ , delivered to an electric appliance is directly proportional to the voltage,  $V$ , across it and the current,  $I$ , passing through it. In symbols:

$$P \propto VI.$$

If either  $V$  or  $I$  are doubled,  $P$  changes in the same proportion — that is, it doubles. If both  $V$  and  $I$  are doubled,  $P$  changes by a factor of four.

The net force acting on an object is related to the object's acceleration and mass by the equation:

$$F_{\text{net}} = ma.$$

This is another example of direct variation. The net force is directly proportional to the mass and acceleration of the object. In this case, the constant of proportionality is 1 and has no units.

When one quantity is directly proportional to the reciprocal of another, the relationship is defined as an inverse variation. For example, the electrical resistance  $R$  of a length of wire is directly proportional to the reciprocal of the cross-sectional area  $A$  of the wire. In symbols:

$$R \propto \frac{1}{A}$$

$$\Rightarrow R = \frac{k}{A} \text{ where } k \text{ is a constant of proportionality.}$$

$R$  is said to be inversely proportional to  $A$ .

$$\text{If } R_1 = \frac{k}{A_1}$$

$$\text{and } R_2 = \frac{k}{A_2}$$

then

$$k = R_1A_1 = R_2A_2.$$

The product of  $R$  and  $A$  is constant. If  $A$  is doubled,  $R$  is halved. If  $A$  is tripled,  $R$  is divided by three. If  $A$  is halved,  $R$  doubles.

### Revision question A1.5

- (a) The power delivered to an electrical device is directly proportional to the voltage across the device and the electric current flowing through the device. If the power delivered to the device is initially 20 W, what will it be if:
- the voltage is tripled
  - the current is doubled
  - the voltage and electric current are both tripled
  - the voltage is doubled and the current is halved?



- (b) The kinetic energy  $E_k$  of an object is directly proportional to the mass  $m$  of the object and the square of the speed  $v$  of the object. The formula for kinetic energy is:

$$E_k = \frac{1}{2}mv^2.$$

- (i) What is the constant of proportionality in this example of direct variation?  
 (ii) If the speed of an object was tripled, by what factor would its kinetic energy change?  
 (iii) If an object A has twice as much kinetic energy as an identical object B, what is the value of the following ratio:

$$\frac{\text{speed of object A}}{\text{speed of object B}} ?$$

- (c) The density  $\rho$  of a substance is described by the equation:

$$\rho = \frac{m}{V} \text{ where } m \text{ is the mass of the substance and } V \text{ is its volume.}$$

If a given mass of air with a density of  $1.4 \times 10^{-3} \text{ g cm}^{-3}$  is compressed so that it occupies one-third of its original volume, what is its new density?

## Using trigonometry

Trigonometric ratios can be used to find the sum or difference of vectors and to resolve vectors into components.

In the right-angled triangle ABC shown in the figure at right, the length of one side can be found if the lengths of the other two sides are known by using Pythagoras's theorem. Thus:

$$c^2 = a^2 + b^2.$$

Trigonometric ratios can be used to determine:

- an angle if the lengths of any two sides are known
- the length of an unknown side if one angle and the length of one other side are known.

In the right-angled triangle ABC:

$$\begin{aligned} \sin B &= \frac{b}{c} & \sin A &= \frac{a}{c} \\ \Rightarrow b &= c \sin B & \Rightarrow a &= c \sin A \\ \cos B &= \frac{a}{c} & \cos A &= \frac{b}{c} \\ \Rightarrow a &= c \cos B & \Rightarrow b &= c \cos A \\ \tan B &= \frac{b}{a} & \tan A &= \frac{a}{b} \end{aligned}$$

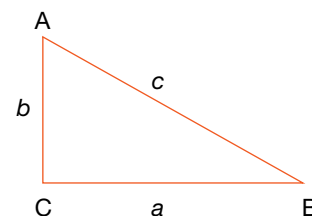

## Adding vectors

When vector quantities such as forces are added together, direction needs to be taken into account as well as magnitude. The labelled arrows that represent vectors can be used to perform the addition by placing them 'head to tail'. When adding pairs of vectors, the labelled arrows are redrawn so that the 'tail' of the second arrow abuts the 'head' of the first arrow. The sum of the vectors is represented by the arrow drawn between the tail of the first vector and the head of the second. The diagrams on the following page illustrate how this method has been used to determine the net force in the three examples shown. The sum of the vectors ( $F_{\text{net}}$ ) is represented by the brown coloured arrow in each case.

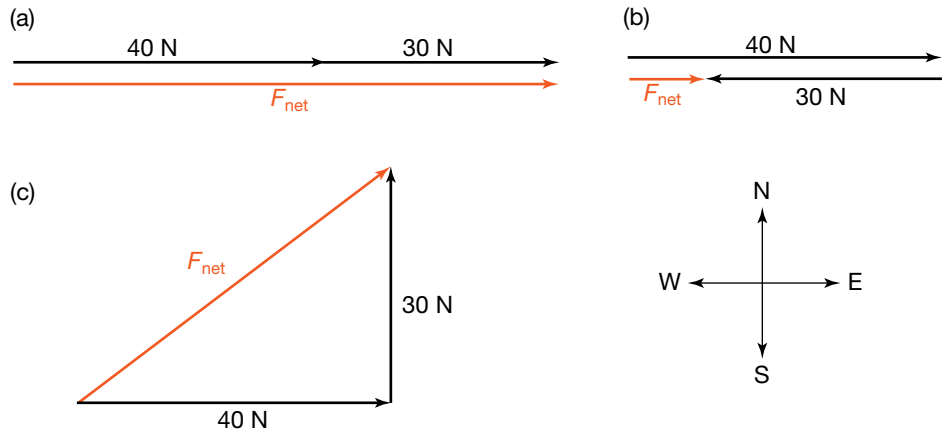

### Determining the magnitude of a vector sum

The vectors in the diagrams above have been drawn to scale. That means that the length of the arrow representing the vector sum can be measured. The magnitude of the vector sum can then be calculated. The direction of the vector sum is given by the direction in which the third arrow points. If the vectors have been drawn to scale, the direction can be determined by measuring the appropriate angle with a protractor.

The magnitude of the vector sum can also be determined by using Pythagoras's theorem. The vector addition shown in example (c) above results in a right-angled triangle. The arrow representing the vector sum makes up the hypotenuse of a right-angled triangle, illustrated in the figure at left. The magnitude that it represents is given by:

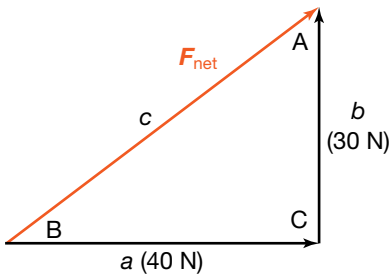

$$\begin{aligned}
 c^2 &= a^2 + b^2 \\
 &= (40)^2 + (30)^2 \\
 &= 2500 \quad (\text{calculating the sum of the squares of both sides}) \\
 \Rightarrow c &= 50 \text{ N.} \quad (\text{taking the positive square root of the sum of the squares})
 \end{aligned}$$

The direction of the net force can be found using trigonometric ratios.

$$\begin{aligned}
 \tan B &= \frac{30}{40} \\
 &= 0.75 \\
 B &= 37^\circ
 \end{aligned}$$

The vector sum, and net force, is 50 N at an angle of N53°E (53° clockwise from north).

You will get the same result no matter in which order you add the vectors.

#### Revision question A1.6

Find the sum of each of the pairs of vectors shown in (a) and (b) below.

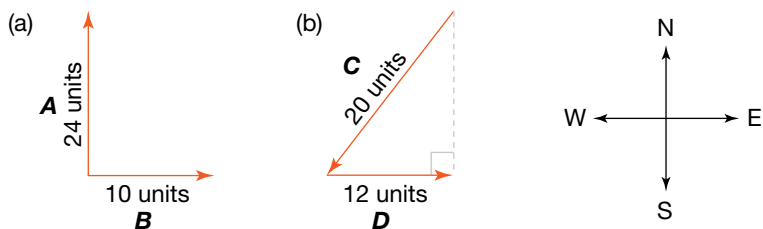

## Subtracting vectors

One vector can be subtracted from another simply by adding its negative. This technique is used in the 'As a matter of fact' box on page 167. It works because subtracting a vector is the same as adding the negative of that vector (just as subtracting a positive number is the same as adding the negative of that number). Another way to *subtract* vectors is to place them tail to tail as in the figure on the right. The difference between the vectors  $a$  and  $b$  ( $b - a$ ) is given by the vector that begins at the head of vector  $a$  and ends at the head of vector  $b$ .

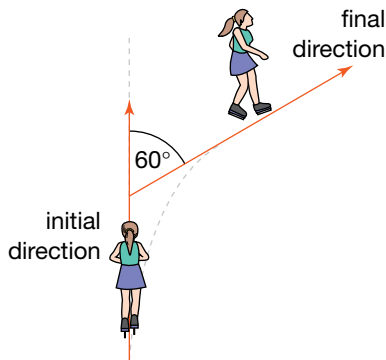
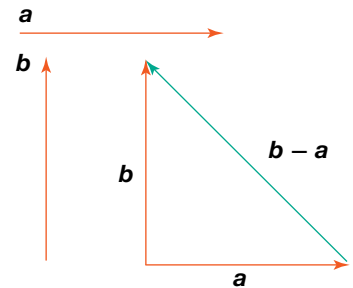

### Revision question A1.7

An ice-skater moving at  $20 \text{ m s}^{-1}$  turns right through an angle of  $60^\circ$  as shown in the figure on the left while maintaining the same speed. What is the magnitude of her change in velocity?

## Finding vector components

The magnitude of vector components can be determined using trigonometric ratios. The vector  $P$  in the figure at right can be resolved into vertical and horizontal components.

The magnitude of the horizontal component, labelled  $P_H$ , is given by:

$$P_H = P \cos 40^\circ \quad (\text{since } \cos 40^\circ = \frac{P_H}{P})$$

$$\Rightarrow P_H = 500 \text{ units} \times 0.7660$$

$$= 383 \text{ units.}$$

The magnitude of the vertical component, labelled as  $P_V$ , is given by

$$P_V = P \sin 40^\circ \quad (\text{since } \sin 40^\circ = \frac{P_V}{P})$$

$$\Rightarrow P_V = 500 \text{ units} \times 0.6428$$

$$= 321 \text{ units.}$$

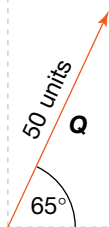
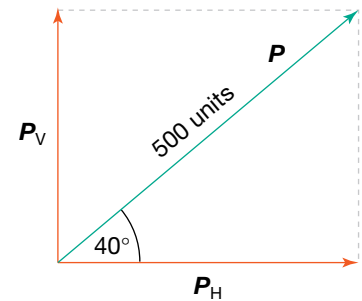

### Revision question A1.8

Determine the magnitude of the horizontal component and vertical component of the vector  $Q$  in the figure on the left.

## Adding three or more vectors

When three or more vectors are to be added together, they can be drawn to scale and placed 'head to tail' in any order. The sum of the vectors is represented by the arrow drawn between the tail of the first vector and the head of the last vector added.

### Sample problem A1.1

In a three-way 'tug of war', three teams (A, B and C) pull horizontally away from the knot joining the ropes with forces of 3000 N north, 2500 N south-west and 2800 N south-east respectively. Determine the net horizontal force exerted on the knot.

**Solution:** The figure below shows a diagram of the tug of war and two different ways of determining the net force on the knot. The order of adding the three vectors is not important as long as the magnitude and direction of each vector is not changed. The net force is 800 N in a direction  $15^\circ$  east of south.

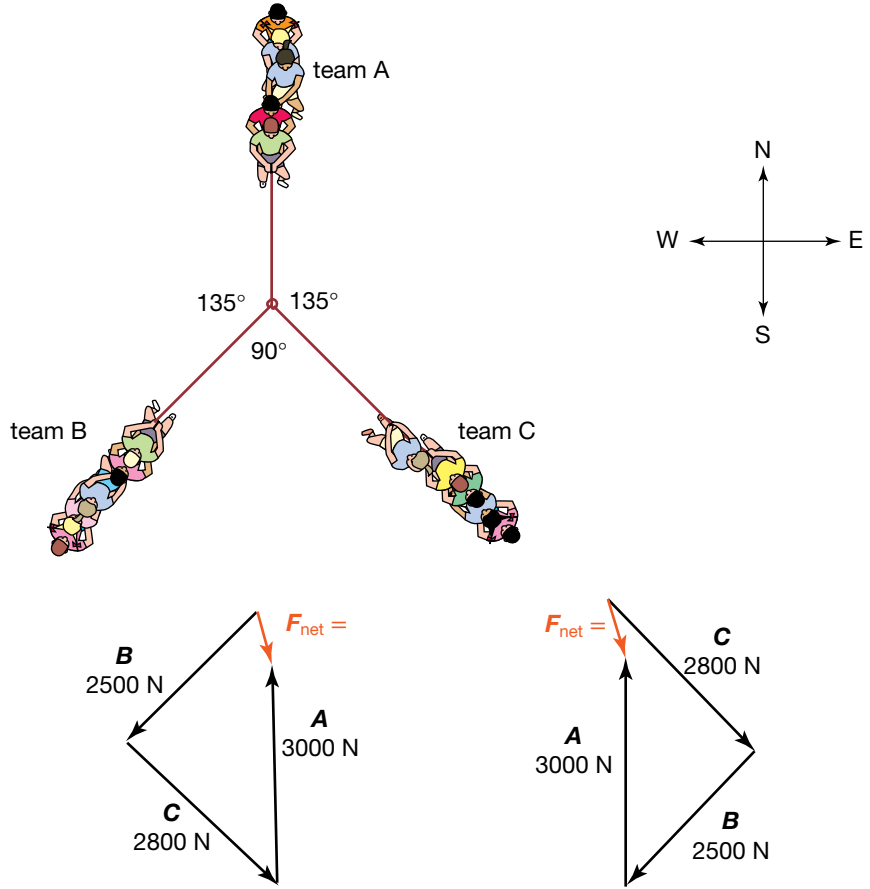

### Revision question A1.9

Determine the net force in each of the situations illustrated in (a) to (h).

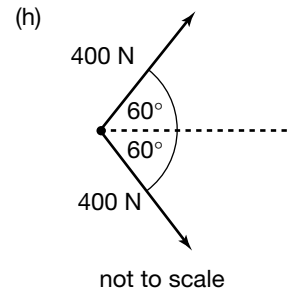
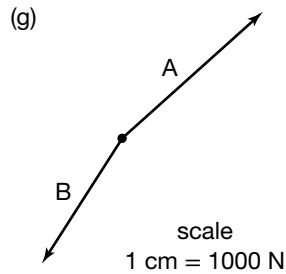
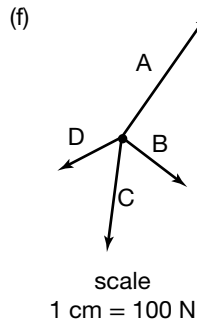
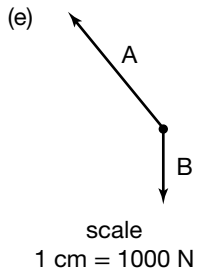
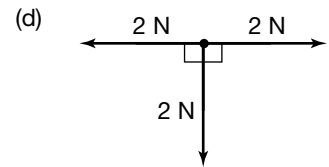
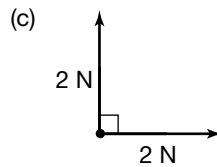
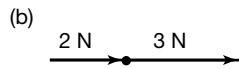
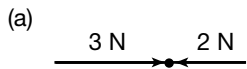

### Revision question A1.10

In each of the illustrations below, the net force is shown along with all but one of the contributing forces. Use a vector diagram to determine the magnitude and direction of the missing force.

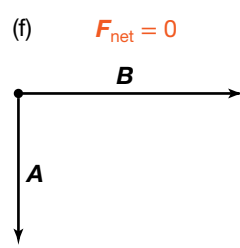
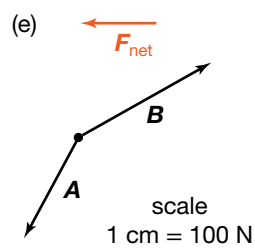
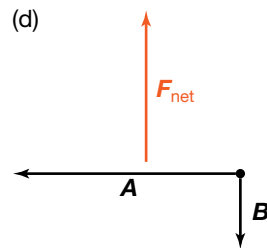
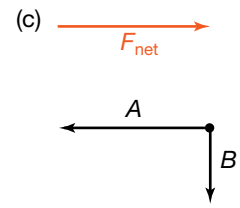
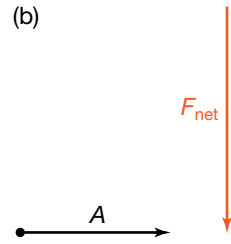
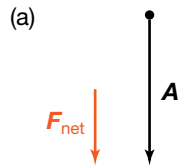

# Appendix 2 PERIODIC TABLE OF THE ELEMENTS

		Alkali metals ↓ Group 1	Alkaline earth metals ↓ Group 2								
Period 1		<table border="1"> <tr> <td>1 Hydrogen <b>H</b> 1.0</td> <td>2 Helium <b>He</b> 4.0</td> </tr> </table>		1 Hydrogen <b>H</b> 1.0	2 Helium <b>He</b> 4.0	<p>Key</p> <ul style="list-style-type: none"> <li>← Atomic number</li> <li>← Name</li> <li>← Symbol</li> <li>← Relative atomic mass</li> </ul>					
1 Hydrogen <b>H</b> 1.0	2 Helium <b>He</b> 4.0										
Period 2		3 Lithium <b>Li</b> 6.9	4 Beryllium <b>Be</b> 9.0								
Period 3		11 Sodium <b>Na</b> 23.0	12 Magnesium <b>Mg</b> 24.3	<b>Transition metals</b>							
				Group 3	Group 4	Group 5	Group 6	Group 7	Group 8	Group 9	
Period 4		19 Potassium <b>K</b> 39.1	20 Calcium <b>Ca</b> 40.1	21 Scandium <b>Sc</b> 45.0	22 Titanium <b>Ti</b> 47.9	23 Vanadium <b>V</b> 50.9	24 Chromium <b>Cr</b> 52.0	25 Manganese <b>Mn</b> 54.9	26 Iron <b>Fe</b> 55.8	27 Cobalt <b>Co</b> 58.9	
Period 5		37 Rubidium <b>Rb</b> 85.5	38 Strontium <b>Sr</b> 87.6	39 Yttrium <b>Y</b> 88.9	40 Zirconium <b>Zr</b> 91.2	41 Niobium <b>Nb</b> 92.9	42 Molybdenum <b>Mo</b> 96.0	43 Technetium <b>Tc</b> (98)	44 Ruthenium <b>Ru</b> 101.1	45 Rhodium <b>Rh</b> 102.9	
Period 6		55 Caesium <b>Cs</b> 132.9	56 Barium <b>Ba</b> 137.3	57–71 Lanthanoids	72 Hafnium <b>Hf</b> 178.5	73 Tantalum <b>Ta</b> 180.9	74 Tungsten <b>W</b> 183.8	75 Rhenium <b>Re</b> 186.2	76 Osmium <b>Os</b> 190.2	77 Iridium <b>Ir</b> 192.2	
Period 7		87 Francium <b>Fr</b> (223)	88 Radium <b>Ra</b> (226)	89–103 Actinoids	104 Rutherfordium <b>Rf</b> (261)	105 Dubnium <b>Db</b> (262)	106 Seaborgium <b>Sg</b> (266)	107 Bohrium <b>Bh</b> (264)	108 Hassium <b>Hs</b> (267)	109 Meitnerium <b>Mt</b> (268)	

## Lanthanoids

57 Lanthanum <b>La</b> 138.9	58 Cerium <b>Ce</b> 140.1	59 Praseodymium <b>Pr</b> 140.9	60 Neodymium <b>Nd</b> 144.2	61 Promethium <b>Pm</b> (145)	62 Samarium <b>Sm</b> 150.4	63 Europium <b>Eu</b> 152.0
---------------------------------------	------------------------------------	--	---------------------------------------	--	--------------------------------------	--------------------------------------

## Actinoids

89 Actinium <b>Ac</b> (227)	90 Thorium <b>Th</b> 232.0	91 Protactinium <b>Pa</b> 231.0	92 Uranium <b>U</b> 238.0	93 Neptunium <b>Np</b> (237)	94 Plutonium <b>Pu</b> (244)	95 Americium <b>Am</b> (243)
--------------------------------------	-------------------------------------	--	------------------------------------	---------------------------------------	---------------------------------------	---------------------------------------

			Non-metals				Halogens	Noble gases
			Group 13	Group 14	Group 15	Group 16	Group 17	Group 18
			5 Boron <b>B</b> 10.8	6 Carbon <b>C</b> 12.0	7 Nitrogen <b>N</b> 14.0	8 Oxygen <b>O</b> 16.0	9 Fluorine <b>F</b> 19.0	10 Neon <b>Ne</b> 20.2
			13 Aluminium <b>Al</b> 27.0	14 Silicon <b>Si</b> 28.1	15 Phosphorus <b>P</b> 31.0	16 Sulfur <b>S</b> 32.1	17 Chlorine <b>Cl</b> 35.5	18 Argon <b>Ar</b> 39.9
Group 10	Group 11	Group 12	31 Gallium <b>Ga</b> 69.7	32 Germanium <b>Ge</b> 72.6	33 Arsenic <b>As</b> 74.9	34 Selenium <b>Se</b> 79.0	35 Bromine <b>Br</b> 79.9	36 Krypton <b>Kr</b> 83.8
28 Nickel <b>Ni</b> 58.7	29 Copper <b>Cu</b> 63.5	30 Zinc <b>Zn</b> 65.4	49 Indium <b>In</b> 114.8	50 Tin <b>Sn</b> 118.7	51 Antimony <b>Sb</b> 121.8	52 Tellurium <b>Te</b> 127.6	53 Iodine <b>I</b> 126.9	54 Xenon <b>Xe</b> 131.3
46 Palladium <b>Pd</b> 106.4	47 Silver <b>Ag</b> 107.9	48 Cadmium <b>Cd</b> 112.4	81 Thallium <b>Tl</b> 204.4	82 Lead <b>Pb</b> 207.2	83 Bismuth <b>Bi</b> 209.0	84 Polonium <b>Po</b> (210)	85 Astatine <b>At</b> (210)	86 Radon <b>Rn</b> (222)
78 Platinum <b>Pt</b> 195.1	79 Gold <b>Au</b> 197.0	80 Mercury <b>Hg</b> 200.6		114 Flerovium <b>Fl</b> (289)	Metals ←	116 Livermorium <b>Lv</b> (292)		
110 Darmstadtium <b>Ds</b> (271)	111 Roentgenium <b>Rg</b> (272)	112 Copernicium <b>Cn</b> (285)						

64 Gadolinium <b>Gd</b> 157.3	65 Terbium <b>Tb</b> 158.9	66 Dysprosium <b>Dy</b> 162.5	67 Holmium <b>Ho</b> 164.9	68 Erbium <b>Er</b> 167.3	69 Thulium <b>Tm</b> 168.9	70 Ytterbium <b>Yb</b> 173.1	71 Lutetium <b>Lu</b> 175.0
--	-------------------------------------	--	-------------------------------------	------------------------------------	-------------------------------------	---------------------------------------	--------------------------------------

96 Curium <b>Cm</b> (247)	97 Berkelium <b>Bk</b> (247)	98 Californium <b>Cf</b> (251)	99 Einsteinium <b>Es</b> (252)	100 Fermium <b>Fm</b> (257)	101 Mendelevium <b>Md</b> (258)	102 Nobelium <b>No</b> (259)	103 Lawrencium <b>Lr</b> (262)
------------------------------------	---------------------------------------	---	---	--------------------------------------	--	---------------------------------------	---

# Appendix 3 SOME USEFUL ASTRONOMICAL DATA

	Mean radius of orbit (au)	Mean radius of orbit (km)	Orbital period (years)	Equatorial radius (km)	Mass (kg)
Sun				$6.96 \times 10^5$	$1.99 \times 10^{30}$
Mercury	0.387	$5.79 \times 10^7$	0.241	$2.44 \times 10^3$	$3.30 \times 10^{23}$
Venus	0.723	$1.08 \times 10^8$	0.615	$6.05 \times 10^3$	$4.87 \times 10^{24}$
Earth	1.00	$1.50 \times 10^8$	1.00	$6.37 \times 10^3$	$5.97 \times 10^{24}$
Moon	$2.57 \times 10^{-3}$	$3.84 \times 10^5$	27.32 days	$1.74 \times 10^3$	$7.35 \times 10^{22}$
Mars	1.52	$2.28 \times 10^8$	1.88	$3.40 \times 10^3$	$6.42 \times 10^{23}$
Jupiter	5.20	$7.78 \times 10^8$	11.9	$7.15 \times 10^4$	$1.90 \times 10^{27}$
Saturn	9.58	$1.43 \times 10^9$	29.7	$6.03 \times 10^4$	$5.68 \times 10^{26}$
Titan	$8.20 \times 10^{-3}$	$1.22 \times 10^6$	15.9 days	$2.58 \times 10^3$	$1.35 \times 10^{23}$
Uranus	19.2	$2.87 \times 10^9$	84.6	$2.59 \times 10^4$	$8.68 \times 10^{25}$
Neptune	30.1	$4.50 \times 10^9$	166	$2.48 \times 10^4$	$1.02 \times 10^{26}$
Pluto*	39.48	$5.91 \times 10^9$	248	$1.18 \times 10^3$	$1.46 \times 10^{22}$

\*Pluto is no longer classified as a planet. Scientists have recently hypothesised that a ninth planet may exist, but it has not yet been directly observed.

Alpha Centauri	4.37 light-years away
The Milky Way	$1.50 \times 10^5$ light-years across
Andromeda	$2.30 \times 10^6$ light-years away
Edge of observable universe	$4.65 \times 10^{10}$ light-years away

Source: Data derived from [www.jpl.nasa.gov](http://www.jpl.nasa.gov)



# Appendix 4 USEFUL FORMULAE

Velocity; acceleration	$v = \frac{\Delta x}{\Delta t}; a = \frac{\Delta v}{\Delta t}$
Equations for constant acceleration	$v = u + at$ $s = ut + \frac{1}{2}at^2$ $v^2 = u^2 + 2as$ $s = \frac{1}{2}(v+u)t$
Newton's Second Law of Motion	$\Sigma F = ma$
Circular motion	$a = \frac{v^2}{r} = \frac{4\pi^2 r}{T^2}$
Hooke's Law	$F = -k\Delta x$
Elastic potential energy	$E_{ep} = \frac{1}{2}k(\Delta x)^2$
Kinetic energy	$E_k = \frac{1}{2}mv^2$
Newton's Law of Universal Gravitation	$F = \frac{GM_1M_2}{r^2}$
Gravitational field strength	$g = \frac{GM}{r^2}$
Universal gravitational constant	$G = 6.67 \times 10^{-11} \text{ N m}^2 \text{ kg}^{-2}$
Mass of Earth	$M_E = 5.98 \times 10^{24} \text{ kg}$
Radius of Earth	$R_E = 6.37 \times 10^6 \text{ m}$
Gravitational potential energy near the Earth's surface	$E_{gp} = mgh$
Acceleration due to gravity at the Earth's surface	$g = -9.8 \text{ ms}^{-2}$
Voltage; power	$V = RI; P = VI = I^2R$
Resistors in series	$R_T = R_1 + R_2$

Resistors in parallel	$\frac{1}{R_T} = \frac{1}{R_1} + \frac{1}{R_2}$
Transformer action	$\frac{V_1}{V_2} = \frac{N_1}{N_2}$
Time constant for an RC circuit	$\tau = RC$
AC voltage and current	$V_{\text{rms}} = \frac{1}{\sqrt{2}} V_{\text{peak}}; I_{\text{rms}} = \frac{1}{\sqrt{2}} I_{\text{peak}}$
Magnetic force	$F = IlB$
Electromagnetic induction	emf: $\varepsilon = \frac{-N\Delta\Phi}{\Delta t}$ ; flux $\Phi = BA$
Transmission losses	$V_{\text{drop}} = I_{\text{line}} R_{\text{line}}; P_{\text{loss}} = I_{\text{line}}^2 R_{\text{line}}$
Mass of an electron	$m_e = 9.1 \times 10^{-31} \text{ kg}$
Charge of an electron	$e = -1.6 \times 10^{-19} \text{ C}$
Planck's constant	$h = 6.63 \times 10^{-34} \text{ J s}$ $= 4.14 \times 10^{-15} \text{ eV s}$
Speed of light	$c = 3.0 \times 10^8 \text{ m s}^{-1}$
Photoelectric effect	$E_{k_{\text{max}}} = hf - W$
Photon energy	$E = hf$
Photon momentum	$p = \frac{h}{\lambda}$
De Broglie wavelength	$\lambda = \frac{h}{p}$
Speed, frequency and wavelength	$v = f\lambda$
Energy transformation for electrons in an electron gun (< 100 keV)	$\frac{1}{2} m_e v^2 = eV$
Radius of electron path in a magnetic field	$r = \frac{m_e v}{eB}$
Magnetic force on a moving electron	$F = evB$
Bragg's Law	$n\lambda = 2d \sin \theta$
Electric field between charged plates	$E = \frac{V}{d}$

Band gap energy	$E = \frac{hc}{\lambda}$
Snell's law	$n_1 \sin \theta_1 = n_2 \sin \theta_2$
Sound intensity level (in dB)	$L(\text{dB}) = 10 \log_{10} \left( \frac{I}{I_0} \right)$ where $I_0 = 1.0 \times 10^{-12} \text{ W m}^{-2}$
Lorentz factor	$\gamma = \frac{1}{\sqrt{1 - \frac{v^2}{c^2}}}$
Time dilation	$t = t_0 \gamma$
Length contraction	$l = \frac{L_0}{\gamma}$
Relativistic mass	$m = m_0 \gamma$
Total energy	$E_{\text{total}} = E_k + E_{\text{rest}} = mc^2$

## Prefixes and units

p = pico- =  $10^{-12}$

n = nano- =  $10^{-9}$

$\mu$  = micro- =  $10^{-6}$

m = milli- =  $10^{-3}$

k = kilo- =  $10^3$

M = mega- =  $10^6$

G = giga- =  $10^9$

t = tonne =  $10^3 \text{ kg}$

# Glossary

## A

**absolute refractive index:** the relative refractive index for light travelling from a vacuum into the substance. It is commonly referred to as the refractive index.

**absorption spectrum:** a spectrum produced when light passes through a cool gas. It includes a series of dark lines that correspond to the frequencies of light absorbed by the gas.

**acceleration:** the rate of change of velocity. It is a vector quantity.

**air resistance:** the force applied to an object, opposite to its direction of motion, by the air through which it is moving

**alternating current:** an electric current that reverses direction at short, regular intervals

**amplitude:** the amplitude of a wave is the size of the maximum disturbance of the medium from its normal state.

**angle of incidence:** the angle between an incident ray and the normal

**angle of reflection:** the angle between a reflected ray and the normal

**angle of refraction:** the angle between a refracted ray and the normal

**antinodal lines:** lines where constructive interference occurs on a surface

**antinode:** a point at which constructive interference takes place

## B

**black body:** an ideal absorber of energy. It absorbs all electromagnetic radiation that falls on it and does not reflect any.

## C

**cathode ray:** a stream of electrons emitted between a cathode (negative electrode) and an anode (positive electrode) in an evacuated tube

**centre of mass:** the point at which all of the mass of an object can be considered to be when modelling the external forces acting on the object

**centripetal acceleration:** the centre-directed acceleration of an object moving in a circle

**coherent:** two waves are coherent if there is a constant relative phase between them.

**commutator:** a device that reverses the direction of the current flowing through an electric circuit

**compression:** a region of increased pressure in a medium during the transmission of a sound wave

**constructive interference:** the addition of two wave disturbances to give an amplitude that is greater than either of the two waves

**continuous spectrum:** a spectrum that has no gaps. There are no frequencies or wavelengths missing from the spectrum.

**critical angle:** the angle of incidence for which the angle of refraction is  $90^\circ$ . The critical angle exists only when light passes from one substance into a second substance with a lower refractive index.

## D

**de Broglie wavelength:** the wavelength associated with a particle or discrete piece of matter

**destructive interference:** the addition of two wave disturbances to give an amplitude that is less than either of the two waves

**diffraction:** the spreading out, or bending of, waves as they pass through a small opening or move past the edge of an object

**diffuse reflection:** reflection from a rough or irregular surface

**direct current:** an electric current that flows in one direction only

**dispersion:** the separation of light into different colours as a result of refraction

**displacement:** a measure of the change in position of an object. It is a vector quantity.

**distance:** a measure of the length of the path taken when an object changes position. It is a scalar quantity.

## E

**eddy current:** an electric current induced in the iron core of a transformer. Eddy currents result in undesirable energy losses from the transformer.

**elastic collision:** a collision in which the total kinetic energy is conserved

**electromagnet:** a temporary magnet produced when a solenoid wound around an iron core carries an electric current

**electromagnetic induction:** the generation of an electric current in a coil as a result of a changing

magnetic field or as a result of the movement of the coil within a constant magnetic field

**electron gun:** a device to provide free electrons for a linear accelerator. It usually consists of a hot wire filament with a current supplied by a low-voltage source.

**electron volt:** the quantity of energy acquired by an elementary charge ( $q_e = 1.6 \times 10^{-19} \text{ C}$ ) passing through a potential difference of 1 V. Thus,  $1.6 \times 10^{-19} \text{ J} = 1 \text{ eV}$ .

**emf:** a source of voltage that can cause an electric current to flow

**emission spectrum:** a spectrum produced when light is emitted from an excited gas and passed through a spectrometer. It includes a series of bright lines on a dark background. The bright lines correspond to the frequencies of light emitted by the gas.

**excited state:** a state in which an electron has more energy than its ground state

## F

**fluorescent:** describes the light emitted from materials as a result of exposure to external radiation.

**frequency:** the frequency of a periodic wave is the number of times that it repeats itself every second.

## G

**galvanometer:** an instrument used to detect small electric currents

**generator:** a device in which a rotating coil in a magnetic field is used to produce a voltage

**geostationary:** a satellite in geostationary orbit is stationary relative to a point directly below it on Earth's surface. A geostationary orbit has the same period as the rotation of Earth.

**gravitational potential energy:** the energy stored in an object as a result of its position relative to another object to which it is attracted by the force of gravity

**ground state:** a state of an electron in which it has the least possible amount of energy

## I

**impulse:** the product of a force and the time interval over which it acts. Impulse is a vector quantity with SI units of N s.

**incandescent:** describes luminous objects that produce light as a result of being hot

**induced voltage:** a voltage that is caused by the separation of charge due to the presence of a magnetic field

**induction:** the process of producing magnetic properties in one object due to the presence of another object with magnetic properties

**inertial reference frames:** reference frames that are not accelerating

**instantaneous speed:** the speed at a particular instant of time

**instantaneous velocity:** the velocity at a particular instant of time

**invariant:** describes a quantity that has the same value in all reference frames

**ionisation energy:** the amount of energy required to be transferred to an electron to enable it to escape from a material

**isolated system:** a system on which no external forces act. The only forces acting on objects in the system are those applied by other objects in the system.

## K

**kinetic energy:** the energy associated with the movement of an object. Like all forms of energy, kinetic energy is a scalar quantity.

## L

**light-emitting diode (LED):** a small semiconductor diode that emits light when a current passes through it

**line emission spectrum:** a spectrum that shows the discrete frequencies or wavelengths produced by an excited material

**longitudinal waves:** waves for which the disturbance is parallel to the direction of propagation

**luminous:** describes objects that give off their own light

## M

**magnetic field:** the property of the space around a magnet that causes an object in that space to experience a force due only to the presence of the magnet

**magnetic flux:** a measure of the amount of magnetic field passing through an area. It is measured in webers (Wb).

**mass-energy:** as mass and energy are equivalent, they can be described as a single concept, mass-energy. The mass-energy of an object is given by  $E = mc^2$ .

**momentum:** the product of the mass of an object and its velocity. Momentum is a vector quantity.

**monochromatic:** describes light of a single frequency and, hence, very clearly defined colour

## N

**nanocrystal:** a very small crystal with only a few hundred to a thousand atoms

**net force:** the vector sum of all the forces acting on an object

**nodal lines:** lines where destructive interference occurs on a surface, resulting in no displacement of the surface

**node:** a point at which destructive interference takes place

**normal:** a line that is perpendicular to a surface or a boundary between two surfaces

## O

**optical fibre:** a thin tube of transparent material that allows light to pass through without being refracted into the air or another external medium

## P

**path difference:** the difference between the lengths of the paths from each of two sources of waves to a point

**peak current:** the amplitude of an alternating current

**peak-to-peak voltage:** the difference between the maximum and minimum voltages of a DC voltage

**peak voltage:** the amplitude of an alternating voltage

**periodic waves:** disturbances that repeat themselves at regular intervals

**period (circular motion):** the time taken for a complete revolution of a repeated circular motion

**period (wave motion):** the time it takes a source to produce a complete wave. This is the same as the time taken for a complete wave to pass a given point.

**photoelectric effect:** the release of electrons from a metal surface as a result of exposure to electromagnetic radiation

**photon:** a discrete bundle of electromagnetic radiation. Photons can be thought of as discrete packets of light energy with zero mass and zero electric charge.

**p-n junction:** the border region between p-type and n-type materials that have been fused together

**polarisation:** the blocking of transverse waves except for those travelling in a single plane

**power rating:** the power rating, or wattage, of an electrical appliance indicates the rate at which it uses electrical energy.

**proper length:** the length of an object measured in its rest frame

**proper time:** the time measured in a frame of reference where the events occur at the same point in space. The proper time of a clock is the time the clock measures in its own reference frame.

## Q

**quantised:** describes quantities that cannot be divided or broken up into smaller parts

**quantum:** a small quantity of a fixed amount

## R

**rarefaction:** a region of reduced pressure in a medium during the transmission of a sound wave

**ray:** a very narrow pencil-like beam of light

**refraction:** the bending of light as it passes from one medium into another

**regular reflection:** also referred to as specular reflection; reflection from a smooth surface

**relative:** describes a quantity that has different values for different observers

**relative refractive index:** a measure of how much light bends when it travels from any one substance into any other substance

**resonance:** the condition where a medium responds to a periodic external force by vibrating with the same frequency as the force

**rest mass:** the mass of an object measured at rest

**restoring force:** the force applied by a spring to resist compression or extension

**RMS voltage:** root mean square voltage, the value of the constant DC voltage that would produce the same power as AC voltage across the same resistance

**road friction:** the force applied by the road surface to the wheels of a vehicle in a direction opposite to the direction of motion of the vehicle

## S

**scalar quantity:** a quantity that has magnitude (size) but not direction

**semiconductor:** a material that has a resistivity between that of conductors and insulators

**solenoid:** a coil of wire wound into a cylindrical shape

**spectrometer:** a device used to disperse light into its spectrum

**specular reflection:** *see* regular reflection

**speed:** a measure of the time rate at which an object moves over a distance

**standing wave:** the superposition of two wave trains with the same frequency and amplitude travelling in opposite directions. Standing waves are also referred to as stationary waves because they do not appear to move through the medium. The positions of no disturbance (a node) and maximum disturbance (an antinode) remain fixed.

**step-down transformer:** a transformer that produces an output (secondary) voltage that is less than the input (primary) voltage

**step-up transformer:** a transformer that produces an output (secondary) voltage that is greater than the input (primary) voltage

**strain potential energy:** the energy stored in an object as a result of a reversible change in shape

**superposition:** the adding together of amplitudes of two or more waves passing through the same point

## T

**terminal velocity:** the constant velocity reached by a falling object when the upwards air resistance becomes equal to the downward force of gravity

**thermal spectrum:** the spectrum produced by a body due to its temperature

**thought experiments:** also known as gedanken experiments; imaginary scenarios designed to explore what the laws of physics predict would happen

**time dilation:** the slowing of time by clocks moving relative to the observer

**torque:** the turning effect of a force

**total internal reflection:** the total reflection of light from a boundary between two substances. It occurs when the angle of incidence is greater than the critical angle.

**transformer:** a device in which two multi-turn coils are wound around an iron core. One coil acts as an input while the other acts as an output. The purpose of the transformer is to produce an output AC voltage that is different from the input AC voltage.

**transverse waves:** waves for which the disturbance is at right angles to the direction of propagation

## V

**vector quantity:** a quantity that has direction as well as magnitude (size)

**velocity:** a measure of the time rate of displacement, or the time rate of changing position. It is a vector quantity.

## W

**wave:** a transfer of energy through a medium without any net movement of matter

**wavelength:** the distance between successive corresponding parts of a periodic wave

**wave-particle duality:** describes light as having characteristics of both waves and particles. This duality means that neither the wave model nor the particle model adequately explains the properties of light on its own.

**work function:** the minimum energy required to release an electron from the surface of a material

**work:** the energy transferred to or from another object by the action of a force. Work is a scalar quantity.

## X

**X-ray:** a form of electromagnetic radiation with a frequency above that of ultraviolet radiation

# Answers to numerical questions

**eBookplus**

## Digital documents

Fully worked solutions and answers to all questions can be found in the Resources section of your eBookPLUS.

## Chapter 1

### Page 5

- 1.1 (a)  $3.0 \text{ m s}^{-2}$   
(b)  $7.1 \text{ m s}^{-2}$ , south-west direction  
(c)  $7.1 \text{ m s}^{-2}$ , direction S61°E

### Page 8

- 1.2 (a)  $3.0 \text{ m s}^{-2}$  south  
(b)  $-5.0 \text{ m s}^{-2}$  north  
(c)  $8.3 \text{ m s}^{-1}$  south

### Page 10

- 1.3 (a)  $30 \text{ m s}^{-1}$   
(b)  $0.625 \text{ m s}^{-2}$   
(c)  $25 \text{ m s}^{-1}$   
(d) (i)  $21.25 \text{ m s}^{-1}$ , rounded to  $21 \text{ m s}^{-1}$   
(ii)  $25 \text{ m s}^{-1}$

### Page 14

- 1.4 (a) (i) 500 N  
(ii) 100 N  
(b) (i) 1200 N  
(ii) 1300 N  
(iii) 4500 N

### Page 18

- 1.5 (a) (i) 248 N, rounded to 250 N  
(ii) 852 N, rounded to 850 N  
(b)  $1.98 \text{ m s}^{-2}$ , rounded to  $2.0 \text{ m s}^{-2}$

### Page 19

- 1.6 (a) 44 m  
(b)  $29.4 \text{ m s}^{-1}$ , rounded to  $29 \text{ m s}^{-1}$

### Page 22

- 1.7 (a) 76.4 m, rounded to 76 m  
(b) 160 m  
(c)  $39.2 \text{ m s}^{-1}$ , rounded to  $39 \text{ m s}^{-1}$   
(d)  $44.4^\circ$ , rounded to  $44^\circ$

### Page 24

- 1.8 (a)  $3.13 \text{ m s}^{-1}$ , rounded to  $3.1 \text{ m s}^{-1}$   
(b)  $0.638 = 0.64 \text{ s}$

### Page 27

- 1.9 (a)  $13.52 \text{ km h}^{-1}$ , rounded to  $14 \text{ km h}^{-1}$   
(b) 0.767 s, rounded to 0.77 s  
(c) 6.18 m

### Page 29

- 1.10 (a) 3.1 m  
(b)  $1.3 \text{ m s}^{-1}$   
(c)  $0.828 \text{ m s}^{-1}$ , rounded to  $0.83 \text{ m s}^{-1}$   
(d)  $0 \text{ m s}^{-1}$

### Page 33

- 1.11 (a)  $22 \text{ m s}^{-2}$   
(b) 1326 N, rounded to 1300 N

### Page 36

- 1.12  $13.3 \text{ m s}^{-1}$

### Page 37

- 1.13 (a)  $61^\circ$   
(b) 1011 N, rounded to 1000 N

### Page 38

- 1.14 (a) 1127 N, rounded to 1100 N  
(b) 1715 N, rounded to 1700 N  
(c) 2.9, almost three times the weight force

### Page 39

- 1.15 (a) 2507 N, rounded to 2500 N  
(b)  $4.849 \text{ m s}^{-1}$ , rounded to  $4.8 \text{ m s}^{-1}$

## Review questions

- $3.5 \text{ m s}^{-1}$
- $10 \text{ m s}^{-1}$  down
- (a)  $25 \text{ km h}^{-1} \text{ s}^{-1}$  S  $37^\circ$  E  
(b)  $6.9 \text{ m s}^{-2}$  S  $37^\circ$  E
- (a) F (b) C (c) X
- (a) 40 N (b) 10 N (c) 34 N
- (a)  $3.5 \text{ m s}^{-2}$  opposite to the direction of motion  
(b)  $7.0 \times 10^3 \text{ N}$
- (a) 200 m (b)  $14 \text{ m s}^{-1}$  (c) 24 000 N (d) 32 000 N
- (b)  $1.4 \times 10^4 \text{ N}$  (c) Zero (d)  $5.1 \times 10^3 \text{ N}$
- (a) No direction as the net force is zero  
(b) 300 N
- (a) 380 N north  
(b)  $1.7 \times 10^3 \text{ N}$  north
- 1000 N
- $8.5^\circ$
- (a) Vertical equals  $15 \text{ m s}^{-1}$ , horizontal equals  $13 \text{ m s}^{-1}$   
(b)  $10 \text{ m s}^{-1}$ ,  $4.3 \text{ m s}^{-1}$   
(c)  $5 \text{ m s}^{-1}$ , zero  
(d) Zero,  $10 \text{ km h}^{-1}$   
(e)  $17 \text{ m s}^{-1}$ ,  $29 \text{ m s}^{-1}$
- (a) 5.5 s (b)  $55 \text{ m s}^{-1}$
- (a) 3.6 s (b) 16 m
- (a)  $14 \text{ m s}^{-1}$  (b) 1.4 s (c) 0.7 m  
(d)  $14 \text{ m s}^{-1}$ ,  $88^\circ$  down from the horizontal  
(e) (i) 0 N (ii) 5000 N downwards
- (b)  $28 \text{ m s}^{-1}$  (c) 0.041 m
- No, as the range is only 4.9 m.
- $45^\circ$
- (a)  $4.8 \text{ m s}^{-1}$  (b)  $18^\circ$  (c) 0.12 m
- (a) 0.69 s  
(b) Vertical equals 2.4 m, horizontal equals 4.8 m  
(c) 0.32 s



32. (a) 0.80 s  
 (b) Vertical equals 3.2 m, horizontal equals 9.1 m  
 (c) 0.90 s (d) 19 m
33. (a) 18 m (b) 15 m s<sup>-1</sup> at 37° to the horizontal
34. 5.5 m s<sup>-1</sup>
35. 19°
36. (a) 0.024 m s<sup>-2</sup> towards the centre of the circle  
 (b) 1.6 N towards the centre of the circle
37. Lucy
38. (a) 0.050 m s<sup>-2</sup> towards the centre of the circle  
 (b) 1.7 N towards the centre of the circle  
 (c) 75 N towards the centre of the circle
39. (a) 0.95 m s<sup>-2</sup> towards the centre of the circle  
 (b) 0.11 N towards the centre of the circle
42. (a) 11.7 m s<sup>-1</sup>  
 (b) 92.0 m s<sup>-2</sup> towards the centre of the circle  
 (c) 4.60 N towards the centre of the circle  
 (d) 4.60 N towards the centre of the circle  
 (e) 4.63 N
43. (a) 12 N (11.8 N)  
 (b) 11 m s<sup>-1</sup> (10.9 m s<sup>-1</sup>)  
 (c) 1.2 s
44. (a) 350 N towards the centre of the circle  
 (b) 350 N towards the centre of the circle  
 (c) It will increase to 5.0 m.
45. 78.9 kg
46. 82° (i.e. banking alone is not the solution)
47. (b) (i) 8000 N downwards (ii) 6.3 m s<sup>-1</sup>
48. (a) 4.5 m s<sup>-1</sup> (b) 3.3 × 10<sup>2</sup> N upwards

## Chapter 2

### Page 49

- 2.1 (a) 2000 N s east  
 (b) 2500 N  
 (c) 2500 N

### Page 50

- 2.2 4.5 m s<sup>-1</sup>

### Page 54

- 2.3 (a) 10 m s<sup>-1</sup>  
 (b) 20 000 N s  
 (c) 20 000 N s  
 (d) 6.0 m s<sup>-1</sup>

### Page 56

- 2.4 (a) 8.0 × 10<sup>4</sup> J  
 (b) 4000 N

### Page 58

- 2.5 (a) 14 700 J, rounded to 1.5 × 10<sup>4</sup> J  
 (b) 22 m s<sup>-1</sup>

### Page 59

- 2.6 (a) 1.94 J  
 (b) 25 cm

### Page 61

- 2.7 (a) 100 N m<sup>-1</sup>  
 (b) 4.0 J
- 2.8 (a) 0.128 J, rounded to 0.13 J  
 (b) 0.051 m = 5.1 cm

### Page 66

- 2.9 (a) (i) -0.25 m s<sup>-1</sup>, which means the green car goes backwards.  
 (ii) -1.0 m s<sup>-1</sup>  
 (b) Both collisions are inelastic.

## Review questions

5. (a) 2.0 m s<sup>-1</sup> south (c) 2.0 m s<sup>-1</sup> south
6. (a) 140 kg m s<sup>-1</sup> east  
 (b) Between Dean and Melita, 2.5 m from Dean  
 (c) 1.2 m s<sup>-1</sup> east  
 (d) 1.2 m s<sup>-1</sup> east  
 (e) 60 N s east
7. (a) 2.9 m s<sup>-1</sup> east (b) 3.4 × 10<sup>4</sup> N s west
9. (a) 1.8 × 10<sup>5</sup> J (b) 1.8 × 10<sup>5</sup> J (c) 4.5 × 10<sup>5</sup> N
11. (a) 9.7 × 10<sup>3</sup> J (b) 1.4 × 10<sup>4</sup> N (c) approx. 2 × 10<sup>6</sup> N
12. (a) 4100 J (b) 5500 J (c) 3.1 × 10<sup>5</sup> J
13. (a) 4–5 × 10<sup>5</sup> J (b) 800–1000 J (c) 15–30 J  
 (d) 1.5–3.0 J (e) 0.5–1.0 J
14. (a) 10 N up (b) 38 N m<sup>-1</sup> (c) A (d) 1.3 J (e) B
15. (a) 3.5 × 10<sup>6</sup> J (b) 3.5 × 10<sup>6</sup> J
16. (b) 1.8 × 10<sup>3</sup> J (c) 1.8 × 10<sup>3</sup> J
17. (a) 10 000 (b) 10 000 (c) 1
18. (a) 7500 J (b) 16 m s<sup>-1</sup> (c) None (d) 238 N
19. (a) 2.5 J (b) 1.4 m s<sup>-1</sup> (c) 220 N m<sup>-1</sup>
20. (a) 7.7 mm (b) 900 J (c) 2.0 m s<sup>-1</sup>
21. (b) 67 N m<sup>-1</sup> (c) 100 N m<sup>-1</sup>
24. (a) 30 m s<sup>-1</sup> east (b) 0.038 (approx.  $\frac{1}{26}$ )
25. (a) Zero (b) Each vehicle has a final speed of 60 km h<sup>-1</sup>.
26. (a) 1.8 × 10<sup>4</sup> J (b) 2.9 × 10<sup>4</sup> J
27. (a) 0.30 m s<sup>-1</sup> north (b) 75%
29. (a) 5.4 N opposite to the original direction of motion  
 (b) 0.54 N s opposite to the original direction of motion
31. (a) 60 kg m s<sup>-1</sup> (b) 90 kg m s<sup>-1</sup>
33. (a) (i) -980 N s (ii) -980 N s (iii) -196 m s<sup>-2</sup>  
 (iv) -3920 m s<sup>-2</sup>  
 (b) Driver 19.6 gs; passenger head 392 gs

## Chapter 3

### Page 77

- 3.1 B

### Page 89

- 3.7 4.329 min

### Page 90

- 3.8 1 min 48 s  
 3.9 0.866c

### Page 97

- 3.11 (a) 1934 m  
 (b) 209 m

### Page 99

- 3.12 3 × 10<sup>16</sup> kg

### Page 101

- 3.13  $\sqrt{\frac{3}{4}}c$

## Review questions

6. 100 km h<sup>-1</sup> towards the front of each car.
9. (a) 10 km h<sup>-1</sup> s<sup>-1</sup> (b) 10 km h<sup>-1</sup> s<sup>-1</sup>
15. c
25. (a) 1.048 28  
 (b) 95.4 beats per minute (it beats more slowly.)
26. (a) Unchanged  
 (b) It would be contracted to 60% of its proper length.  
 (c) c
27. (a) 2.82 s (b) 0.7053 m
28. (a) 5 min (b) 0.78c
29. (a) 3.0 light-years  
 (b) 4.3 years  
 (c) 6 years

30. (a) 57 m (b) 190 m (c)  $6.3 \times 10^{-7}$  s  
(d)  $2.67 \times 10^{-7}$  s
31. 43.6 m
33. 5.97 km
34. 7.839 microseconds
37. (a)  $4.5 \times 10^{17}$  J  
(b)  $1.4 \times 10^{19}$  J  
(c)  $6.0 \times 10^{19}$  J  
(d)  $1.2 \times 10^{20}$  J
40. A
42. (a) 117 kg  
(b)  $4.2 \times 10^{18}$  J
43.  $5.4 \times 10^{44}$  J
44.  $2.99 \times 10^{18}$  kg
45.  $2.3 \times 10^{20}$  J
46.  $1.0 \times 10^4$  m s<sup>-1</sup>
47.  $2.25 \times 10^{16}$  J
51.  $8.18 \times 10^{-31}$  kg

## Chapter 4

### Page 110

- 4.1 Earth:  $3.38 \times 10^{18}$  m<sup>3</sup> s<sup>-2</sup>  
Mercury:  $3.36 \times 10^{18}$  m<sup>3</sup> s<sup>-2</sup>  
Venus:  $3.35 \times 10^{18}$  m<sup>3</sup> s<sup>-2</sup>  
Mars:  $3.36 \times 10^{18}$  m<sup>3</sup> s<sup>-2</sup>  
Jupiter:  $3.37 \times 10^{18}$  m<sup>3</sup> s<sup>-2</sup>  
Saturn:  $3.38 \times 10^{18}$  m<sup>3</sup> s<sup>-2</sup>  
Uranus:  $3.37 \times 10^{18}$  m<sup>3</sup> s<sup>-2</sup>  
Neptune:  $3.37 \times 10^{18}$  m<sup>3</sup> s<sup>-2</sup>  
Pluto:  $3.36 \times 10^{18}$  m<sup>3</sup> s<sup>-2</sup>

### Page 111

- 4.2 (a)  $1.98 \times 10^{20}$  N  
(b)  $1.98 \times 10^{20}$  N

### Page 113

- 4.3  $1.99 \times 10^{30}$  kg

### Page 116

- 4.5 (a)  $g_{\text{Moon}} = 1.619$  N kg<sup>-1</sup>, rounded to 1.6 N kg<sup>-1</sup>;  
 $1.619 \times 6 = 9.7$ , which is close to 9.8 N kg<sup>-1</sup>.  
(b) Jupiter, 24.7 N kg<sup>-1</sup>

### Page 120

- 4.6 (b) Number of little squares =  $3.6 \times 10^{14}$  J, just under three times

### Review questions

1. (a) 97 N downwards (b) 97 N (c)  $6.41 \times 10^6$  m
2. (a) (i) 9.80 N kg<sup>-1</sup> (ii)  $6.9 \times 10^2$  N  
(b) (i) 3.70 N kg<sup>-1</sup> (ii)  $2.6 \times 10^2$  N  
(c) (i) 8.87 N kg<sup>-1</sup> (ii)  $6.2 \times 10^2$  N  
(d) (i) 0.667 N kg<sup>-1</sup> (ii) 47 N
3.  $1.6 \times 10^{22}$  kg
4.  $3.5 \times 10^{22}$  N
9. (a)  $8.73$  m s<sup>-2</sup> (b) 8.78 N kg<sup>-1</sup>  
(d)  $1.1 \times 10^7$  N (e)  $2.2 \times 10^{-4}$  N
10.  $0.034$  m s<sup>-2</sup>
16.  $\frac{r_{\text{Saturn}}}{r_{\text{Venus}}} = 13$
17.  $3.02 \times 10^8$  m
20.  $4.2 \times 10^7$  m
23. (a)  $1.4 \times 10^9$  J (b)  $5.8 \times 10^3$  s or 97 minutes  
(c)  $\frac{r^3}{T^2} = \text{constant}$  for any satellite of Earth  
(d) (a) would be halved and (b) would remain the same.
24. (a)  $1.4 \times 10^4$  N (b)  $1.7 \times 10^{10}$  J (c)  $7.9 \times 10^3$  m s<sup>-1</sup>
25. (a) 8.78 N kg<sup>-1</sup> (b) 615 N (c) Zero

## Chapter 5

### Page 134

- 5.2  $1.08 \times 10^5$  N C<sup>-1</sup> to the left

### Page 138

- 5.3 (a) 20 000 V m<sup>-1</sup> (b) The strength would increase.

### Page 140

- 5.4 (a)  $1.6 \times 10^{-16}$  J  
(b)  $1.9 \times 10^7$  m s<sup>-1</sup>

### Review questions

2. (a)  $1.3 \times 10^{-4}$  N  
(b)  $1.5 \times 10^{-3}$  N; the forces remain equal.  
(c)  $1.0 \times 10^{-3}$  N, but the force is now an attractive force.  
(d)  $4.0 \times 10^{-3}$  N
3. 7.9 N
4.  $r$  would need to be increased by a factor of 2.8.
5. 30 km
6.  $2.04 \times 10^{-8}$  C
7. 8 cm from the  $4 \times 10^{-6}$  C charge or 1.2 cm from the  $9 \times 10^{-6}$  C charge
9.  $6.15 \times 10^{13}$  electrons
10.  $8.2 \times 10^{-8}$  N
11.  $6.0 \times 10^{-3}$  N
12.  $8.5 \times 10^{-2}$  N
13.  $1.3 \times 10^2$  N
14.  $5.7 \times 10^{13}$  C
15.  $1.76 \times 10^{12}$  C
16.  $F = 512$  N,  $a = 7.7 \times 10^{28}$  m s<sup>-2</sup>
17.  $2.9 \times 10^{-9}$  N
18.  $5.0 \times 10^5$  N C<sup>-1</sup> up
19.  $2.0 \times 10^6$  N C<sup>-1</sup> up
20.  $1.02 \times 10^{-7}$  N C<sup>-1</sup>
28. West
29. (a) Right  
(b) Right (and stronger than in (a))
30.  $1.2 \times 10^7$  N C<sup>-1</sup>
31.  $1.44 \times 10^{-3}$  N C<sup>-1</sup>
32. (a)  $4.0 \times 10^{-3}$  N  
(b)  $2.61 \times 10^{-3}$  N  
(c) 90 V
33. (a) The 100 V battery  
(b)  $1.6 \times 10^{-17}$  J  
(c) The answer does not change.  
(d) The answer does not change.  
(e) The electrons would not be accelerated, so would not gain any energy.  
(f) The field strength is doubled.
34. (a)  $1.75 \times 10^{17}$  m s<sup>-1</sup>  
(b)  $1.7 \times 10^{-11}$  s  
(c)  $2.57 \times 10^{-3}$  m  
(d)  $2.57 \times 10^3$  V
35. (a)  $d = \frac{E^2 q}{2mV^2}$  (b)  $8 \times 10^{-13}$  C

## Chapter 6

### Page 155

- 6.2 (a) 1.25 N (b) 2.3 T

### Page 159

- 6.3  $1.05 \times 10^6$  m s<sup>-1</sup>

### Review questions

12. (b) Force up the page  
(c) Force down the page  
(d) Yes
13. 0.07 N

14. 0.18 N
15. 1.4 N
16. 0.0058 N
29. (a)  $4.6 \times 10^{-14}$  N  
(c)  $5.1 \times 10^{16} \text{ m s}^{-2}$
30. (a)  $2.0 \times 10^{-13}$  N  
(b)  $2.2 \times 10^{17} \text{ m s}^{-2}$   
(c)  $1.2 \times 10^{14} \text{ m s}^{-2}$
34. (a) 0.043 mm  
(b) 78 mm  
(c) 16 mm
35. 1.7 mT
36. 6.3 mT
37.  $1.1 \times 10^{-17} \text{ kg m s}^{-1}$
40. (a)  $5.9 \times 10^6 \text{ m s}^{-1}$   
(b)  $3.56 \times 10^4 \text{ V m}^{-1}$  or  $\text{N C}^{-1}$   
(c)  $1.78 \times 10^3 \text{ V}$

## Chapter 7

### Page 168

- 7.1.  $80 \text{ m s}^{-1}$

### Page 173

- 7.2.  $50 \mu\text{Wb}$

### Page 174

- 7.3. (a) 0.018 V  
(b) Anticlockwise

### Page 178

- 7.4. 7.5 A, 10.6 A

### Review questions

3. (a) 0.15 Wb (b)  $1.8 \times 10^{-4} \text{ Wb}$  (c)  $3.0 \times 10^{-3} \text{ Wb}$
12. (a) 0.016 V (b) 17 V (c) 38 V
13. (a) 0.004 A (b) 0.054 A (c) 0.19 A
14. (a) 2000 V (b) Zero
17. (a) 6000 m (b)  $3.0 \times 10^7 \text{ m}^2$  (c) 3000 V
19. 0.024 C
23.  $2.0 \times 10^{-3} \text{ V}$
24. 8.9 V
25. (a) 28 ms (b) 35 Hz (c) 50 mV  
(d) 100 mV (e) 35 mV
26. 6.4 V

## Chapter 8

### Page 187

- 8.1 0.05 or 1:20 — a step-up transformer

### Page 193

- 8.2 (a) (i) 200 A (ii) 40 V (iii) 8.0 kW, 16% (iv) 190 V  
(b) (i) 20 A (ii) 4.0 V (iii) 80 W, 0.16% (iv) 249.6 V

### Review questions

1. 4800 V
2. (a) 4.8 V (b) 450 V
3. (a) 1000 turns (b) 8.3 A (c) 0.42 A
6. (a) Step-down transformer (b) 48 turns
7. (a) 135 V (b) 40.5 V (c) 0.675 A
8. (a) 200 A (b) 12 kW  
(c) 60 V (d) 190 V
- (e) (i) 30 W (ii) 3.0 V (iii) 247 V
9. (a)  $6.0 \Omega$  (b)  $6.2 \Omega$  (c) 232 V  
(d) (i) 2.15  $\Omega$  (ii) 218 V  
(e) Yes (f) Increase
10. (a) 667 A (b) 178 kW  
(c) 267 V (d) 330 kV, 220 MW
11. (a) 25% (b) 0.25%

## Chapter 9

### Page 207

- 9.1  $335 \text{ m s}^{-1}$

### Page 211

- 9.2 (a) 1.8 Hz

### Review questions

1. (a) 21 min, 4.3 min  
(b) 260 min, 240 min
3. (a) 2 s  
(b) 0.5 Hz
4. (a) C  
(b) A and B
5.  $2.1 \times 10^{-15} \text{ s}$
6.  $332 \text{ m s}^{-1}$
7. One wavelength
11. 0.78 s
12.  $1.7 \times 10^3 \text{ m}$
13. 1.02 m
14.  $330 \text{ m s}^{-1}$
15. (a) 1.33 m  
(b) 5.86 m
- 16.

$v \text{ (m s}^{-1}\text{)}$	$f \text{ (Hz)}$	$\lambda \text{ (m)}$
335	500	0.67
300	12	25
1500	5000	0.30
60	24	2.5
340	1000	0.34
260	440	0.59

21. 1.50 m
23. (b) 1.0 m (c)  $330 \text{ m s}^{-1}$
24. (a)  $4.8 \text{ m s}^{-1}$  (b) 0.60 m (c) 20 cm  
(d) 1.2 m (e) 8
31. (a) 0.50 m (b) 18.125 m (c) 3.0 m
32. (d) 20.40 m
33. (a) 1.7 m
34. (a) 0.229 m, 0.040 m (b)  $69^\circ, 9.4^\circ$  (c) 5.2 cm
36. (a)  $20 \text{ m s}^{-1}$  (b) 416 Hz (c)  $170 \text{ m s}^{-1}$
37. (a)  $68 \text{ m s}^{-1}$
38.  $110 \text{ km h}^{-1}$
39. (a)  $85 \text{ m s}^{-1}$

## Chapter 10

### Page 229

- 10.1 1.29

### Page 233

- 10.2  $1.24 \times 10^3 \text{ m s}^{-1}$

### Page 234

- 10.3  $\sin^{-1}\left(\frac{y}{x}\right)$

### Page 243

- 10.4 (a)  $2.1 \times 10^{-6} \text{ m}$

### Page 245

- 10.5 (a) 650 nm  
(b) Red  
(c) The distance between the bands would be smaller as  $\lambda_{\text{blue}} < \lambda_{\text{red}}$ .

**Page 251**

10.6  $\lambda = 6.67 \times 10^{14}$  Hz,  $T = 1.50 \times 10^{-15}$  s

**Page 252**

10.7  $4.4 \times 10^{14}$  Hz

**Review questions**

- 29°, 6°
- 1.5
- 36°, 65°
- (a)  $\theta_{\text{air}} = 25^\circ$ ,  $\theta_{\text{acetone}} = 18.1^\circ$ ,  $\theta_{\text{glycerol}} = 16.7^\circ$ ,  $\theta_{\text{ctc}} = 16.8^\circ$   
(b) The angle of refraction in each layer will be exactly the same.
- 19°
- 0.85 cm
- 34.4°
- 24°
- (a)  $n = 1.4$
- 1.49
- 46 cm
- (a)  $7.0 \times 10^{-8}$  m  
(b)  $3.0 \times 10^8$  m s<sup>-1</sup>,  $2.3 \times 10^{-16}$  sec
- $1.82 \times 10^6$  m s<sup>-1</sup>
- $2.1 \times 10^{-15}$  s
- (a) 460 nm  
(b) 310 nm
- Red light: 19.8°; blue light: 19.7°. The difference is 0.1°.
- Red light: 24.6°; blue light: 24.2°
- (a) Red light: 1.67 cm; deep blue light: 1.69 cm  
(b) The deep blue light is shifted more, by 0.02 cm.
- (a) Red light:  $1.98 \times 10^8$  m s<sup>-1</sup>; violet light:  $1.96 \times 10^8$  m s<sup>-1</sup>  
(b) Red light: 27.8°; violet light: 27.5°. The path through the glass is 11.31 cm for red light and 11.27 cm for violet light.
- Constructive: 1.06  $\mu\text{m}$ , 2.12  $\mu\text{m}$ , 3.18  $\mu\text{m}$  ...  
Destructive: 0.53  $\mu\text{m}$ , 1.59  $\mu\text{m}$ , 2.65  $\mu\text{m}$  ...
- (b) (i) 0 (ii) 950 nm (iii) 1266 nm
- $2.58 \times 10^{-3}$  m
- 450 nm

**Chapter 11****Page 262**

11.1  $4.4 \times 10^{14}$  Hz

**Page 263**

11.2  $1.4 \times 10^{28}$  photons s<sup>-1</sup>

**Page 268**

- (a) 78.75 eV = 79 eV  
(b) A stopping potential of 79 eV will bring these electrons to rest.  
(c)  $5.3 \times 10^6$  m s<sup>-1</sup>  
(d)  $4.8 \times 10^{-24}$  N s

**Page 269**

11.4 3.0 V

**Page 274**

11.6 2.3 eV  
11.7  $2.2 \times 10^{-18}$  J

**Page 279**

- (a)  $1.4 \times 10^{-19}$  J  
(b)  $3.29 \times 10^{-19}$  J = 2.1 eV  
(c)  $f_0 = 4.96 \times 10^{14}$  Hz,  $\lambda = 605$  nm  
(d) The photoelectric effect will not occur, as there is insufficient photon energy.

**Page 281**

- (a) See the first table at the bottom of the page.  
(c) (i)  $6.7 \times 10^{-34}$  J s =  $4.2 \times 10^{-15}$  eV s  
(ii)  $2.1 \times 10^{14}$  Hz  
(iii)  $1.4 \times 10^{-19}$  J = 0.88 eV  
(e)  $2.93 \times 10^{-19}$  J = 1.8 eV  
(f) The photocurrent would halve to 19  $\mu\text{A}$ .  
(g) 1.7 V

**Review questions**

- (a)  $6.53 \times 10^{-7}$  m (b)  $2.18 \times 10^{-15}$  s
- For green light at approximately 510 nm, this represents  
 $\frac{2 \times 10^{-17} \text{ J/s}}{3.9 \times 10^{-19} \text{ J/photon}} \approx 50$  photons s<sup>-1</sup>.
- See the second table at the bottom of the page.  
 $\frac{\text{rate of emission of red photons}}{\text{rate of emission of blue photons}} = 1.33$
- (a)  $5.3 \times 10^5$  m s<sup>-1</sup>  
6. 1.1 V

Wavelength of light used (nm)	Frequency of light used $\times 10^{14}$ (Hz)	Photon energy of light used, $E_{\text{photon}}$ (eV)	Stopping voltage readings (V)	Maximum photo-electron energy, $E_e$ (J)
390	7.69	3.19	2.36	$3.78 \times 10^{-19}$
524	5.73	2.38	1.54	$2.46 \times 10^{-19}$

	Source	Wavelength	Frequency	Energy	Momentum
(a)	Infra-red from CO <sub>2</sub> laser	10.6 $\mu\text{m}$	$2.83 \times 10^{13}$ Hz	$1.87 \times 10^{-20}$ J, 0.117 eV	$6.25 \times 10^{-29}$ kg m s <sup>-1</sup>
(b)	Red helium-neon laser	633 nm	$4.74 \times 10^{14}$ Hz	$3.14 \times 10^{-19}$ J, 1.96 eV	$1.05 \times 10^{-27}$ kg m s <sup>-1</sup>
(c)	Yellow sodium lamp	589 nm	$5.09 \times 10^{14}$ Hz	$3.37 \times 10^{-19}$ J, 2.11 eV	$1.125 \times 10^{-27}$ kg m s <sup>-1</sup>
(d)	UV from eximer laser	0.193 $\mu\text{m}$	$1.55 \times 10^{15}$ Hz	$1.03 \times 10^{-18}$ J, 6.42 eV	$3.43 \times 10^{-27}$ kg m s <sup>-1</sup>
(e)	X-rays from aluminium	0.988 nm	$3.03 \times 10^{17}$ Hz	$2.01 \times 10^{-16}$ J, 1.25 keV	$6.69 \times 10^{-25}$ kg m s <sup>-1</sup>

8. (a)  $0.85 \mu\text{A}$  (b)  $1.0 \mu\text{A}$   
 (c) The current stays the same,  $1.0 \mu\text{A}$ .  
 (d) No increase in light intensity  
 (e)  $1.7 \text{ V}$ ,  $1.7 \text{ eV} = 2.72 \times 10^{-19} \text{ J}$
9. (a)  $0.67 \text{ V}$  (b)  $1.08 \times 10^{15} \text{ Hz}$  (c)  $9.1 \times 10^{14} \text{ Hz}$
10. (a)  $4.1 \times 10^{-19} = 2.6 \text{ eV}$   
 (b)  $2.1 \text{ eV}$   
 (c)  $\lambda = 265 \text{ nm}$ ,  $p = 2.5 \times 10^{-27} \text{ N s}$
11. The difference is  $0.4 \text{ eV}$  and the second cell has the greater work function.
12. (a)  $1.5 \text{ eV}$ ,  $2.4 \times 10^{-19} \text{ J}$  (b)  $2.5 \text{ V}$   
 (c)  $4.3 \text{ eV}$ ,  $6.9 \times 10^{-19} \text{ J}$
13. (a)  $4.5 \text{ eV}$   
 (b) (i) Electrons emitted with energy  $1.4 \text{ eV}$   
 (ii) Electrons emitted with energy  $0.6 \text{ eV}$   
 (iii) and (iv) No electrons emitted
14. (a)  $2.58 \text{ eV}$ ,  $4.14 \times 10^{-19} \text{ J}$   
 (b)  $2.58 \text{ V}$
15. (a)  $4.6 \times 10^{14} \text{ Hz}$  (b)  $6.5 \times 10^{-7} \text{ m}$   
 (c)  $1.9 \text{ eV}$  (d)  $6.6 \times 10^{-34} \text{ J s}$ ,  $4.1 \times 10^{-15} \text{ eV s}$

## Chapter 12

### Page 297

- 12.1 (a)  $3.9 \text{ eV}$ ,  $9.4 \times 10^{14} \text{ Hz}$   
 (b)  $0.80 \text{ eV}$ :  $n = 2$  to  $n = 1$  transition,  $1.9 \times 10^{14} \text{ Hz}$
- 12.2  $1.59 \times 10^{14} \text{ Hz}$ ,  $1.9 \times 10^{-6} \text{ m}$  or  $1.9 \mu\text{m}$

### Page 310

- 12.3  $\lambda_{\text{electron}} = 184\lambda_{\text{proton}}$ ; the electron has the greater wavelength.

### Page 311

- 12.4  $0.4 \text{ m s}^{-1}$

### Page 312

- 12.5  $2.14 \times 10^6 \text{ m s}^{-1}$

### Page 314

- 12.6 (a)  $5.4 \times 10^2 \text{ V}$  (b)  $\lambda_{\text{proton}} = 100\lambda_{\text{electron}}$
- 12.7 (a)  $6.6 \times 10^{-24} \text{ N s}$   
 (b)  $1.98 \times 10^{-15} \text{ J}$  or  $12.4 \text{ keV}$  for the photon;  $2.4 \times 10^{-17} \text{ J}$  or approximately  $150 \text{ eV}$  for the electron

### Page 322

- 12.8  $\Delta p_x = 5 \times 10^{-25} \text{ N s}$

### Review questions

7. (a), (b), (c), (d) continuous spectrum, temperature related, polychromatic, incoherent, non-polarised  
 (e) discrete spectrum, temperature independent, polychromatic, incoherent, non-polarised  
 (f) discrete spectrum, temperature independent, generally monochromatic incoherent, can be polarised but still developmental  
 (g) discrete spectrum, temperature independent, monochromatic, coherent, generally polarised

8. RGB LEDs consist of three different colour emitters.
9.  $2.15 \text{ eV}$
10.  $6.9 \times 10^{-7} \text{ m}$
11. All photons of the same frequency also have the same phase.
12. (a)  $1.3 \times 10^{-14} \text{ m}$  (b)  $1.7 \times 10^{-10} \text{ m}$   
 (c)  $6.6 \times 10^{-35} \text{ m}$
13. (a)  $5 \text{ keV} = 8.0 \times 10^{-16} \text{ J}$   
 (b)  $2.5 \times 10^{-10} \text{ m}$
15.  $p = 2.3 \times 10^{-24} \text{ N s}$ ,  $\lambda = 2.9 \times 10^{-10} \text{ m}$
16. (a)  $3000 \text{ eV} = 4.8 \times 10^{-16} \text{ J}$   
 (b)  $3.0 \times 10^{-23} \text{ N s}$ ,  $2.2 \times 10^{-11} \text{ m}$   
 (c)  $\frac{\lambda}{w} \approx 0.04$ , diffraction effects not significant  
 (d) Lower accelerating voltage to make wavelength bigger  
 (e)  $2.2 \times 10^{-11} \text{ m}$ ,  $3.0 \times 10^{-23} \text{ N s}$   
 (f)  $9.0 \times 10^{-15} \text{ J} = 5.6 \times 10^4 \text{ eV}$  or  $56 \text{ keV}$
17.  $1.1 \times 10^3 \text{ m s}^{-1}$
18. (b)  $3.9 \times 10^{-11} \text{ m}$  (electron),  $9.1 \times 10^{-13} \text{ m}$  (proton)
19.  $38 \text{ V}$
20. The electron has the shorter wavelength.
21. Ground state  $-10.4 \text{ eV}$ , first excited state  $-5.5 \text{ eV}$ , second excited state  $-3.7$  and third excited state  $-1.6 \text{ eV}$
22. The term 'ground state' defines the lowest energy state of an atom.
23. Energy change =  $3.0 \times 10^{-19} \text{ J} = 1.9 \text{ eV}$
24. (b)  $4.7 \times 10^{-19} \text{ J} = 2.9 \text{ eV}$
25. See the table at the bottom of the page.
26. (c)  $0.7 \text{ eV}$ ,  $2.6 \text{ eV}$ ,  $12.8 \text{ eV}$ ,  $1.9 \text{ eV}$ ,  $12.1 \text{ eV}$ ,  $10.2 \text{ eV}$   
 (d)  $\lambda_{\text{least energy photon}} = 1.8 \times 10^{-6} \text{ m}$ ,  
 $\lambda_{\text{greatest energy photon}} = 9.7 \times 10^{-8} \text{ m}$
28. (c) First excited state to ground transition:  $\lambda = 5.9 \times 10^{-7} \text{ m}$ , second excited state to ground transition:  $\lambda = 3.3 \times 10^{-7} \text{ m}$ , third excited state to ground transition:  $\lambda = 2.9 \times 10^{-7} \text{ m}$
31.  $2.6 \times 10^{-25} \text{ N s}$
32. (a)  $5.3 \times 10^{-20} \text{ N s}$   
 (b)  $1.5 \times 10^{-9} \text{ J} = 9.5 \times 10^9 \text{ eV}$  or  $9.5 \text{ GeV}$
33. In general terms, as the uncertainty in momentum gets smaller, the uncertainty in position increases.
37. The momentum of a person (mass  $70 \text{ kg}$ ) moving with speed  $1 \text{ m s}^{-1}$  is  $70 \text{ N s}$ . If a doorway has a width of  $1 \text{ m}$ , then the uncertainty of the person's sideways momentum is of order  $10^{-34} \text{ N s}$ . This uncertainty is negligible compared to  $70 \text{ N s}$ ; thus, the diffraction effects are unobservable.
38. Classical laws contain no relationship between  $\Delta x$  and  $\Delta p_x$ . On the very small scale, however, it becomes necessary to be mindful of the uncertainty principle, which places a boundary on what we are able to simultaneously know about a system.

## Chapter 13

### Page 336

- 13.3 (a) (i)  $9.6 \pm 0.25 \text{ cm}$  (ii)  $8.5 \pm 0.125 \text{ cm}$   
 (iii)  $11.9 \pm 0.05 \text{ cm}$   
 (b)  $63.9 \pm 0.05 \text{ g}$

	$\lambda$ (nm)	$f$ (Hz)	$E$ (J)	$E$ (eV)	$p$ (N s)
Red light	632	$4.73 \times 10^{14}$	$3.14 \times 10^{-19}$	1.96	$1.05 \times 10^{-27}$
Electron	0.877	—	$3.14 \times 10^{-19}$	1.96	$7.56 \times 10^{-25}$
Blue light	405	$7.41 \times 10^{14}$	$1.46 \times 10^{-24}$	$9.20 \times 10^{-6}$	$1.63 \times 10^{-27}$
Electron	405	—	$4.90 \times 10^{-19}$	3.06	$1.63 \times 10^{-27}$

# Index

## A

absolute refractive index 228  
absolute rest, concept of 74  
absorption spectra  
  absorption of photons by atoms 298  
  compared to emission spectra 298–300  
AC generators 186, 191  
accelerating charged particles 303  
acceleration 4–5  
  calculating for uniform circular motion 312  
  centripetal acceleration 31, 33  
  changing in circular motion 29–31  
  downwards 12  
  equations of motion with constant acceleration 8–10  
  upwards 12  
acceleration–time graphs 6–8  
accuracy of scientific measurement 339  
air resistance 18  
  and projectile motion 27  
airbags 66  
algebraic analysis of motion 8–10  
alternating current (AC) 177  
amplitude  
  of periodic disturbance 177  
  of waves 205  
angle of incidence 203, 227  
angle of reflection 203  
angle of refraction 227  
antinodal lines 212  
antinodes 209  
apps 335  
Aristotle 74, 290  
astronauts 124–5  
atomic theory  
  Bohr's model 294–5  
  Dalton's model 290  
  de Broglie's model 315–16  
  Rutherford's model 294  
atoms  
  absorption of photons 298–300  
  emission of photons 293–7, 300–2  
Aurora Australis 161  
aurorae 161  
Australian Synchrotron 100  
average velocity 28

## B

black bodies 303  
black body radiation 262, 283, 291, 304  
Bohr, Niels 294, 308  
Bohr radius 300

Bragg, William L. 317  
Brahe, Tycho 108

## C

Cardano, Girolamo 130  
cathode rays 263, 291, 292  
cathode-ray oscilloscopes (CRO) 335  
Cavendish, Henry 111, 130  
centre of gravity 16  
centre of mass 16  
centripetal acceleration 31, 33, 112, 124  
charges, magnetic force on 158–60  
Chelyabinsk asteroid 116, 117–21  
chemical reactions 290  
chemistry 290  
circular motion see non-uniform circular motion; uniform circular motion  
classical physics 78, 322  
coherent waves 240  
collisions  
  elastic and inelastic collisions 61–6  
  energy transformations 63–6  
  impulse and momentum 48–9  
  modelling 51–4  
colour  
  effects of interference of waves 215–16  
  frequency and wavelength 250–2  
  producing from white light 237–8  
  as property of light 204  
commutators 157, 177  
compressions 206  
constant acceleration motion, equations of 8–10  
constructive interference 208  
continuous spectrum 298  
continuous variables 332  
controlled variables 332  
Coolidge tube 264  
Copernicus, Nicolas 108  
copper loss 187  
cosmic radiation 95  
coulombs 131  
Coulomb's constant 131  
Coulomb's Law 130–1, 137  
critical angle 234  
Crookes, William 291  
crumple zones 64–5  
current see electric current

## D

Dalton, John 290  
'dark' light 245  
data loggers 335

Davisson, Clinton 310, 312  
DC motors 156–8  
de Broglie, Louis 293, 309, 310, 315–16  
de Broglie wavelength 309–10, 311, 313  
de Coulomb, Charles-Augustin 130–1  
dependent variables 332  
Descartes, René 237  
desert mirages 235  
destructive interference 208  
diamonds 238  
diffraction 216  
  directional spread of different frequencies 217–18  
  of light 246–9  
  of water waves 216–18  
diffuse reflection 203  
digital posters 341–2  
dipole fields 134–5  
direct current (DC) 177  
discrete variables 332  
dispersion of light 237–9  
displacement 3  
distance 3  
DNA structure, and electrical attraction 134–5  
Doppler, Christian Johann 218  
Doppler effect 95, 218–21  
downwards acceleration 12  
driving force 15  
du Fay, Charles 130

## E

$E = mc^2$  97–103  
Earth, origin of magnetism 147  
eddy currents 188  
Edison, Thomas 191  
Einstein, Albert  
  on impossibility of absolute rest 74  
  length contraction thought experiment 91  
  particle model to explain photoelectric effect 262, 272, 282, 283  
  Special Theory of Relativity 73, 80–5, 99, 100, 160  
elastic collisions 62–3  
electric current  
  generating 168–9  
  magnetic effect 149–52  
  magnetic force on 154–5  
  peak current 177  
  source of electrical energy 169–70

- electric DC motors 156–8
  - electric fields
    - calculating strength 137–8
    - calculating value 133
    - changes in potential energy and kinetic energy 136
    - compared to gravitational fields 132
    - comparing with gravitational and magnetic fields 153–4
    - crossed with magnetic fields 161
    - dipole fields 134–5
    - drawing 132–3
    - graphing 135–6
      - as particle accelerators 138–40
      - relationships between force, field; energy and potential 140–1
      - uniform electric fields 136–8
  - electric force constant 131
  - electric power
    - distribution and transmission line losses 189–94
    - energy loss in transformers 187–8
    - Ohm's Law 193–4
    - power ratings of appliances 194
    - transformers 185–8
    - transmission 184–5
    - transmission lines 190
  - electrical appliances, power ratings 194
  - electrical measuring instruments 335
  - electrical meters 156
  - electricity
    - generating current 168–9
    - generating voltage with magnetic field 167–8
  - electromagnetic induction 170–1
  - electromagnetic radiation 220
    - emitted by accelerating charged particles 303
    - as wave phenomenon 291
    - and X-rays 264
  - electromagnetic spectrum 250
  - electromagnetic waves, light as 249–52
  - electromagnetism, theory of 74, 80
  - electromagnets 151
  - electron guns 139, 267
  - electron microscopes 139, 160
  - electron volts 267
  - electrons
    - diffraction through foils 312–14
    - discovery 290, 291, 291–3
    - distance from protons 299–300
    - as elementary particles 292
    - measuring energy associated with 265–7
    - particle models 291
      - as standing waves 315–16
    - wave behaviour 308–14
    - wave-like properties 310–12, 315–16
  - elliptical orbits 108–9
  - emf (electromotive force) 168
    - see also induced emf
  - emission spectra
    - compared to absorption spectra 298–300
    - photon emission by atoms 293–7
  - energy transfers, work in 54–5
  - energy transformations
    - in collisions 63–6
    - work in 54–5
  - equinoxes 108–9
  - excited state (atoms) 296
- F**
- falling down, projectile motion 18–19
  - Faraday, Michael 80, 115, 148, 158, 170, 295
  - Faraday's Law 173, 186
  - Fata Morgana 235–6
  - fields
    - relationships between force, fields, energy and potential 140–1
    - see also electric fields; gravitational fields; magnetic fields
  - Fitzgerald, George 93
  - fixed variables 332
  - Fizeau, Hippolyte 232
  - fluorescence 263–4, 304
  - fluorescent light sources 300–1, 304–6
  - Foucault, Jean Bernard Leon 232
  - frames of reference 78–80
  - Franklin, Benjamin 130
  - freeway barriers, diffraction of sound 217
  - frequency, of periodic waves 177, 208
  - Fresnel, Augustin-Jean 232, 245
  - Fresnel lens 245
  - friction, and uniform circular motion 34–6
- G**
- Galilean relativity 76–7, 85
  - Galilei, Galileo 74–6, 78, 108, 200
  - galvanometers 170
  - Gaulard, Lucien 186
  - general relativity 83
  - generators 177
  - geostationary satellites 122–3
  - Germer, Lester 310
  - Gibbs, John D. 186
  - Gilbert, William 130, 147
  - glass, refractive index 232
  - global positioning system (GPS) 90
  - graphical analysis of motion 5–8
  - gravitation
    - Kepler's laws 108–10, 112
    - Newton's Law of Universal Gravitation 108, 110–14, 116, 122, 130
  - gravitational field strength 57
  - gravitational fields
    - compared to electric fields 132
    - comparing with magnetic and electric fields 153–4
    - kinetic energy and potential energy in 116–21
    - nature of 114–16
    - and refraction of light 229
    - relationships between force, field; energy and potential 140–1
    - using the area under a field graph 121
  - gravitational force, graphing 113–14
  - gravitational potential energy 54, 56–8, 141
  - Gray, Stephen 130
  - Grimaldi, Francesco 246
  - ground state (atoms) 296
- H**
- Hall, David 95–6
  - Halley, Edmund 117
  - Halley's Comet 117
  - hammer throwing 29–31
  - Heisenberg uncertainty principle 291, 299, 318–22
  - Hertz, Heinrich 269–70
  - high jumpers 25
  - Hooke, Robert 59, 245
  - Hooke's Law 59–60
  - horizontal velocity, projectile motion 19–20
  - Huygens, Christiaan 230, 247, 252
- I**
- Ibn Sahl, Abu Sa'd 228
  - impulse
    - in collisions 48–9, 50
    - determining from graphs 49
  - incandescent light sources 199, 294, 304
  - inclined planes, forces acting on moving object 16–18
  - independent variables 332
  - induced emf
    - peak voltage 177
    - peak-to-peak voltage 178
    - principles 173–4
    - producing larger emf 178–9
    - RMS voltage 177
    - rotating a loop 175
    - using Lenz's Law 175–6
    - using magnetic force on charges in wire 176–7
  - induced voltage 167
  - induction 146
  - inelastic collisions 63, 66
  - inertial reference frames 79
  - initial velocity at angle to horizontal, projectile motion 25–7
  - instantaneous speed 3
  - instantaneous velocity 3
    - and uniform circular motion 28–9
  - invariant quantities 80
  - ionisation energy 275
  - isolated systems 51
- K**
- Kepler, Johannes 108–10
  - Kepler's First Law 108, 110
  - Kepler's Second Law 109
  - Kepler's Third Law 109–10, 112, 122
  - kilowatt hours 194
  - kinetic energy 54
    - in electric fields 136
    - in a gravitational field 116–21
    - in special relativity 101

- L**
- Lane-Fox, St George 191
  - Large Hadron Collider 139
  - lasers 301–2
  - Laue spots 264
  - Law of Conservation of Energy 61
  - Law of Conservation of Momentum 50–1, 62
  - Law of Universal Gravitation 108, 110–14, 116, 122, 130
  - left-hand rule (direction of magnetic force) 155
  - Lenard, Philipp 270–2
  - length, measuring instruments 334
  - length contraction 90–5
  - Lenz's Law 173, 175–6
  - level surface, forces on moving object 15–16
  - light
    - colour 204
    - diffraction 246–9
    - dispersion 237–9
    - as electromagnetic waves 249–52, 269
    - Fresnel's biprism 245
    - Huygen's wave model 230–2, 247
    - interference 245–6, 249
    - Lloyd's mirror 246
    - Maxwell's wave model 249–52, 261, 262
    - measuring energy associated with 265
    - Newton's rings 245
    - particle models 230–2, 240, 246, 272, 273–4
    - path difference 241
    - photon model 262
    - plane mirror reflection 202–3
    - polarisation 252–4
    - rainbows 239
    - ray model 202, 229–33
    - reflection 203
    - refraction 227
    - shadows 201–2
    - sources 199
    - spacing of bands in interference pattern 243–5
    - as stream of particles 272
    - total internal reflection and critical angle 233–8
    - visible light 303
    - wave models 230–2, 247, 249–52, 261, 262, 274–5, 281–2
    - wave-particle model 291
    - Young's experiment 239–45
    - see also photoelectric effect
  - light bulbs
    - particle model view 273–4
    - wave model view 274–5
  - light speed 80, 82–6, 200–1, 232–3
  - light-emitting diodes (LED) 306
  - light-years 85
  - line of best fit, drawing 338
  - line emission spectrum 304
  - Lloyd, Humphrey 246
  - local antinodes 213
  - local nodes 213
  - lodestone 146
  - logbook 330, 340, 341
  - longitudinal waves 204, 205, 206
  - Lorentz contraction 92, 93
  - Lorentz factor 88
  - Lorentz, Hendrik 92, 93
  - low-voltage lighting 187
  - Lucretius 146, 147
  - luminous objects 199
- M**
- magnetic compasses 146
  - magnetic fields 148
    - comparing with gravitational and electric fields 153–4
    - crossed with electric fields 161
    - drawing 148
    - measuring 152
    - relationships between force, field; energy and potential 140–1
    - right-hand-grip rule 150
    - strength 148, 152
    - using to generate voltage 167–8
  - magnetic flux 171–2
  - magnetic force
    - on charges 158–60
    - on electric current 154–5
    - rules for determining direction 155
  - magnetic propulsion 156
  - magnetism
    - early ideas about 146–8
    - and electricity 149–52
    - explaining 152–3
  - magnetite 146, 148
  - magnets
    - alnico magnets 151
    - electromagnets 151
    - flexible fridge magnets 152
    - neodymium magnets 152
  - mass, measuring instruments 333
  - mass spectrometers 139, 160
  - matter
    - particle model 290–1
    - wave-like properties 310–12
  - Maxwell, James Clerk 74, 80, 83, 97, 249–52, 261, 262, 283
  - measurement see scientific measurement
  - measuring instruments 332–5
  - meters 156, 335
  - Michelson, Albert 82, 200–1
  - Michelson–Morley experiment 82, 83, 85, 93
  - Microsoft Excel, using 339
  - Millikan, Robert 282
  - Minkowski, Hermann 86
  - mirages 234–6
  - momentum 10
    - in a collision 48–9, 50
    - conservation of 50–1
  - monochromatic light 270
  - Moon
    - period in relation to stars 122
    - period in relation to Sun 122
    - radius of orbit 122
  - Morley, Edward 82
  - motion
    - algebraic analysis 8–10
    - describing 3–5
    - graphical analysis 5–8
    - measuring instruments 334–5
    - modelling at very small scales 322
    - terminology 3
  - muons 96
- N**
- nanocrystals 308
  - neodymium magnets 152
  - net force 11, 17
  - neutrons, discovery 290
  - Newton, Isaac 10, 74, 76, 78, 108, 109, 116, 230, 237, 245, 246
    - laws of motion 10, 75, 83, 90, 110
    - particle model of light 230–2, 240, 246
  - Newtonian mechanics 83, 85–6, 87, 90, 100, 261, 283
  - Newton's First Law of Motion 10–11, 74
  - Newton's Law of Universal Gravitation 108, 110–16, 122, 130
  - Newton's rings 245
  - Newton's Second Law of Motion 11, 13–18, 48, 50, 64, 80
  - Newton's Third Law of Motion 11, 12, 31, 111, 154
  - nodal lines 211–12
  - nodes 209
  - non-uniform circular motion 38–40
  - non-uniform electric fields 141
  - the normal 203, 227
  - normal reaction force 15
- O**
- Oersted, Hans Christian 149, 154
  - Ohm's Law 193–4
  - optical fibres 236–7
  - optical instruments 248
- P**
- p–n junction 306
  - parking spot paradox 94–5
  - particle accelerators 100, 138–40
  - particle model of light 230–2, 240, 246
  - path difference 241
  - peak current 177
  - peak voltage 177
  - peak-to-peak voltage 178
  - Peregrinus, Peter 147
  - period
    - of periodic wave 177, 205
    - of repeated circular motion 28
  - periodic waves 204, 205
  - Philosophia Naturalis Principia Mathematica* (Newton) 111
  - photoelectric cells 284
  - photoelectric effect
    - Einstein's explanation 262, 272–3
    - energy perspective 276
    - explaining Lenard's observations 277–81
    - Hertz's observations of 269–70
    - Lenard's experiment 270–2
    - observations and predictions of different models 285



- and particle model 275–81
- particle model view of light bulb 273–4
- photon model 285
- problems with wave model 281–2
- timeline of key discoveries 285
- photoelectrons, measuring energy of 267–9
- photons 262, 283, 294
  - absorption by atoms 298–300
  - emission by atoms 293–7, 300–2
  - wave properties 316–18
- photovoltaic cells 284
- Planck, Max 261, 262, 273, 283
- Planck's constant 251, 261, 265, 273, 282, 285, 309
- plane mirror reflection 202–3
- polarisation 252–4
- position–time graphs 5–6
- potential energy
  - in electric fields 136
  - in a gravitational field 116–21
- power ratings of electrical appliances 194
- practical investigations
  - benefits of 328
  - digital posters 341–2
  - finding patterns 338–9
  - handling difficulties 340
  - limits to precision of measurements 335–6
  - logbooks 330, 332
  - measuring instruments 332–5
  - presentation of work 340–2
  - repeated measurements 336–8
  - requirements 328–9
  - research proposals 330–2
  - safety 340
  - topic selection 329–30
  - topics 342–4
  - variables 332
  - written reports 341
- precision of scientific measurement 335–6, 339
- Priestley, Joseph 130
- projectile motion
  - and air resistance 27
  - calculations 27
  - falling down 18–19
  - initial velocity at angle to horizontal 25–7
  - modelling vertical and horizontal components 20–2
  - moving and falling 19–22
  - shooting at an angle 25–7
  - vertical projectile motion 22–4
- proper length 92–3
- proper time 89
- proton–electron distance 299–300
- protons, discovery 290
- Ptolemy 108, 228

## Q

- quantised energy levels 295
- quantum mechanics 291, 299, 316

## R

- radio waves 269–70
- rainbows 239
- rarefactions 206
- ray model of light 202, 229–33
- rays of light 202
- reaction force 12
- reference frames 78–80
- reflection
  - regular and diffuse 203
  - total internal reflection 234
  - transverse waves in strings 208–9
  - of waves 208–9
- refraction 227
- regular reflection 203
- relative refractive index 228
- relativistic effects, seeing 95–6
- relativity
  - $E = mc^2$  97–103
  - electromagnetism and 80–6
  - frames of reference 78–80
  - Galilean relativity 76–7, 85
  - general relativity 83
  - nature of 73–4
  - parking spot paradox 94–5
  - principle of 74–6
  - special relativity 80, 82–3, 85, 88, 97–103, 160
  - twins paradox 94
- reliability of scientific measurement 340
- research proposals 330–2
- resistance forces 16
- resistive loss 187
- resonance 221
- rest mass 99
- restoring force 59
- right-hand-grip rule 150, 173
- right-hand-slap rule 155
- RMS (root mean square) voltage 177
- road friction 16
- Robison, John 130
- Roemer, Olaus 200
- roller coasters 39–40
- Röntgen, Wilhelm 263–4
- Rossi, Bruno 95
- Rossi–Hall experiment 95–6
- Rutherford, Ernest 294, 309

## S

- safety, in practical investigations 340
- satellites 122–3
- scalar quantities 3
- scientific measurement
  - accuracy 339
  - key aspects 339–40
  - precision and uncertainty 335–6, 339
  - reliability 340
  - repeated measurements 336–8
  - validity 339–40
- semiconductors 306
- shadows 201–2
- sidereal period 122
- Snellius, Willebrord 227
- Snell's Law 229
- solar cells 284

- solar system
  - elliptical orbits 108–9
  - gravitational fields 114–21
  - Kepler's laws 108–10
  - Newton's Law of Universal Gravitation 108, 110–16, 122, 130
- solar system, useful data 110
- solenoids 150, 151
- sound
  - diffraction around freeway barriers 217
  - directional spread of different frequencies 217–18
  - interference of waves 213–15
- space–time diagrams 86
- special relativity 80, 82–3, 160
  - Einstein's two postulates 83, 85, 86, 88
  - equation  $E = mc^2$  97–103
  - kinetic energy in 101
- spectrometers 293
- specular reflection 203
- speed 3
  - instantaneous speed 3
- speed of light 85–6, 200–1, 232–3
- speed radar guns 73, 220
- springs 58–61
- SQUIDs (Superconducting QUantum Interference Devices) 152
- standing waves 209–11, 315–16
- Stefan–Boltzmann relationship 251
- step-down transformers 187
- step-up transformers 187
- strain potential energy 54
  - and springs 58–61
- Sturgeon, William 151
- the Sun, mass conversion 101–3
- superposition 207–8
- synchrotron radiation 306–8
- synchrotrons 100, 139

## T

- Taylor, Geoffrey 316–17
- tension 33
- terminal velocity 19
- teslas 148
- thermal radiation 303–4
- thermal spectrum 304
- Thomson, G.P. 312
- Thomson, Joseph John 291–2, 312
- thought experiments 87
- time, measuring instruments 334
- time dilation 87–90
- torque 156
- torsion balance 131
- total internal reflection 234
- transformers 185–8
- transmission lines 190
- transverse waves 204
- twins paradox 94

## U

- ultraviolet light 245
- uncertainty of scientific measurement 335–6, 339
- uniform circular motion
  - average velocity 28
  - centripetal acceleration 31, 33

uniform circular motion (*continued*)  
  changing velocities and  
    accelerations 29–31  
  effect on objects inside objects  
    travelling in circles 36–7  
    and friction 34–6  
    instantaneous velocity 28–9  
uniform electric fields 136–8, 140–1  
upwards acceleration 12

## V

validity of scientific measurement 339–40  
variables 332  
vector quantities 3  
velocity 3  
  changing in circular motion 29–31  
  horizontal velocity of projectiles 19–20  
  instantaneous velocity 3  
  vertical velocity of projectiles 20  
velocity–time graphs 6  
vertical distance, travelled over time 19  
vertical projectile motion 22–4  
vertical velocity, projectile motion 20

voltage, generating with magnetic  
  field 167–8  
voltages, in transmission system 190  
von Laue, Max 264–5, 310

## W

water, refractive index 232  
water waves, diffraction 216–17  
wave–particle duality 316  
wave–particle model of light 291, 316  
wavelengths 205  
waves  
  colour effects of interference 215–16  
  interference of 207–16  
  interference with sound 213–15  
  interference in two dimensions 211–13  
  nature of 204  
  polarisation 252–4  
  properties 205–7  
  reflection of 208–9  
  standing waves 209–11  
  transverse standing waves in strings  
    or springs 209–10

webers (Wb) 171  
weight force 12, 15  
Westinghouse, George 191  
white paint 238  
Wien, Wilhelm 161  
Wien's Law 251  
work, in energy transfers and  
  transformations 54  
work function 275

## X

X-rays 263–5

## Y

Young, Thomas 232, 239–40, 245, 249,  
  261  
Young's experiment with light  
  waves 239–45

## Z

Zeno's paradoxes 318