

EDITION FOUR

NELSON

VISUAL  
COMMUNICATION  
DESIGN

VCE UNITS 1-4

KRISTEN GUTHRIE

Nelson Visual Communication Design VCE Units 1–4

4th Edition

Kristen Guthrie

Publishing editor: Debbi Barnes

Project editor: Robyn Beaver

Editor: Katharine Day

Permissions researcher: Debbie Gallagher

Cover design: Kristen Guthrie

Text design: Aisling Gallagher

Production controller: Karen Young

Typeset by: MPS Limited

Any URLs contained in this publication were checked for currency during the production process. Note, however, that the publisher cannot vouch for the ongoing currency of URLs.

© 2017 Kristen Guthrie

#### Copyright Notice

This Work is copyright. No part of this Work may be reproduced, stored in a retrieval system, or transmitted in any form or by any means without prior written permission of the Publisher. Except as permitted under the *Copyright Act 1968*, for example any fair dealing for the purposes of private study, research, criticism or review, subject to certain limitations. These limitations include: Restricting the copying to a maximum of one chapter or 10% of this book, whichever is greater; providing an appropriate notice and warning with the copies of the Work disseminated; taking all reasonable steps to limit access to these copies to people authorised to receive these copies; ensuring you hold the appropriate Licences issued by the Copyright Agency Limited ("CAL"), supply a remuneration notice to CAL and pay any required fees. For details of CAL licences and remuneration notices please contact CAL at Level 15, 233 Castlereagh Street, Sydney NSW 2000, Tel: (02) 9394 7600, Fax: (02) 9394 7601  
Email: [info@copyright.com.au](mailto:info@copyright.com.au)  
Website: [www.copyright.com.au](http://www.copyright.com.au)

For product information and technology assistance,  
in Australia call **1300 790 853**;  
in New Zealand call **0800 449 725**

For permission to use material from this text or product, please email  
[aust.permissions@cengage.com](mailto:aust.permissions@cengage.com)

#### National Library of Australia Cataloguing-in-Publication Data

Guthrie, Kristen, author.

Nelson visual communication design : VCE units 1–4 / Kristen Guthrie.

4th edition.

9780170401784 (paperback)

Includes index.

For secondary school age.

Victorian Certificate of Education examination.

Visual communication--Study and teaching (Secondary)--Victoria.

Visual communication--Textbooks.

#### Cengage Learning Australia

Level 7, 80 Dorcas Street

South Melbourne, Victoria Australia 3205

#### Cengage Learning New Zealand

Unit 4B Rosedale Office Park

331 Rosedale Road, Albany, North Shore 0632, NZ

For learning solutions, visit [cengage.com.au](http://cengage.com.au)

Printed in China by China Translation & Printing Services.

1 2 3 4 5 6 7 21 20 19 18 17



# CONTENTS

About this book	v		
Area of study navigator	vii		
Author acknowledgements	x		
<b>A</b>			
<b>Visual communication design</b>			
<b>Chapter 1 ~ 2D and 3D drawing</b>	<b>2</b>		
3D drawing	3		
2D drawing	24		
<b>Chapter 2 ~ Observational drawing and rendering</b>	<b>43</b>		
Observational drawing	44		
Rendering	48		
<b>Chapter 3 ~ Visualisation and presentation drawing</b>	<b>61</b>		
Visualisation drawing	62		
Presentation drawing	64		
<b>Chapter 4 ~ Purposes of visual communications</b>	<b>69</b>		
Purposes of visual communications	70		
<b>Chapter 5 ~ Design elements and design principles</b>		<b>78</b>	
Design elements		79	
Design principles		97	
<b>Chapter 6 ~ Typography and layout</b>		<b>114</b>	
Typography		115	
History of typography		124	
Layout		129	
<b>Chapter 7 ~ Media, methods and materials</b>		<b>133</b>	
Drawing methods		134	
Printing methods		140	
Digital design		147	
Photography		155	
<b>B</b>			
<b>Design processes</b>			
<b>Chapter 8 ~ Design process</b>		<b>160</b>	
The design brief		161	
Research		164	
Generating ideas		175	
Developing concepts		184	
Refinement		191	
Evaluation		197	
Resolution and production		201	
A pitch as an evaluation technique		203	

**Chapter 9 ~ Design thinking** 204

What is design thinking?	205
Design thinking techniques	206

**Chapter 10 ~ Visual language and analysis** 217

What is visual language?	218
Understanding the user/audience	218
Visual devices	226
Analysing visual communications	230

**C****Design fields and contexts****Chapter 11 ~ Design fields** 241

Visual communication design industry practice	242
Design field: Communication design	246
Design field: Industrial design	249
Design field: Environmental design	253

**Chapter 12 ~ Design in a wider context** 261

The historical context	262
Key movements in design	262
Economic and political factors in design	280

The social context of design	282
Culture, religion and design	283
Technology and design	283
Design and the environment	284

**Chapter 13 ~ Legal and ethical issues in design** 286

Intellectual property	287
Creative Commons	295
Attribution of research	296
Standards	298
Regulations	298
Use of images	299
Sustainability	300

**D****Study resources**

<b>Chapter 14 ~ Coursework and task prompts</b>	<b>307</b>
---	------------

<b>Glossary</b>	<b>320</b>
-----------------	------------

<b>Index</b>	<b>325</b>
--------------	------------

# ABOUT THIS BOOK

Each Area of Study in VCE Visual Communication Design draws upon a broad range of knowledge and skills. A single Outcome may require you to focus on several drawing methods but also demand a grasp of the design process, application of design elements and design principles and a knowledge of copyright issues. This book is structured to assist you to meet the requirements of the study design. Each chapter is applicable to a range of different Areas of Study. Use the chapter navigator to help locate the most pertinent information for each task. Dip in and out of the chapters to build your knowledge during each Unit. Used in combination with the accompanying workbook (*Nelson Visual Communication Design Workbook VCE Units 1-4, third edition*), you will develop confidence in your skills and build the knowledge needed for success in this creative and challenging subject.

## INTRODUCTION TO VISUAL COMMUNICATION DESIGN

Humans are attuned to visual stimuli. We respond to symbols, images and icons for many reasons: because they elicit an emotional response, have some personal or historical significance, or simply attract the eye.

We live in a world where visual communications dominates our environment. It is an integral part of and affects many aspects of our everyday lives. As a means of expressing ideas, information and opinions, we rely on methods of visual communications to convey personal, commercial and professional messages. Additionally, social media, advertising and the constructed environment, for instance, influence how we react to an issue, form an opinion or purchase a product.

Professional designers working in many design fields, including communication design, industrial/product design, architecture, interior design, landscape design and more, understand the power of the visual. Designers apply various methods of visual communications to express ideas, develop concepts and make a visual connection with an audience.

The universal applications of digital technologies have meant that the communication of visual ideas and the presentation of images occur in rapid and sophisticated forms. Ever-changing developments in technology and production methods, as well as social changes, serve to redefine the boundaries of visual language. Understanding visual communication developments and having a grasp of their origins helps us to process and make sense of vast quantities of visual information.

It is important for design students to develop an informed and analytical understanding of the scope and potential of visual communications. The study of Visual Communication Design will help you, as a student, to understand the important role that visual communications plays in our lives.

Throughout your study of Visual Communication Design you will be asked to convey concepts and devise solutions to design problems that rely on visual means for clarification. This book is designed to guide you through the key knowledge and assist you in the development of the key skills required for successful completion of the Visual Communication Design course work.

One of the core elements of Visual Communication Design is the design process. Facilitating a creative progression from an initial brief to the final presentations, the design process provides a defined yet flexible space for imaginative responses and experimentation where concepts are developed and refined. You will be given many opportunities to develop creative and innovative solutions to design problems, challenging you to extend your ideas, thinking, skills and knowledge within the framework of the design process. Design thinking skills are key to your creative development in Visual Communication Design. The ability to devise, analyse and evaluate ideas is a desirable skill readily transferable to other areas of study as well as your future working life.

Visual Communication Design covers a vast amount of information and introduces many practical techniques and methods of production. The practical and theoretical aspects of the subject are intrinsically linked, and a good grasp of both aspects fosters an ability to successfully interpret, analyse and produce effective visual communications.

## WHERE CAN VISUAL COMMUNICATION DESIGN TAKE YOU?

Universities, government organisations and businesses have come to recognise what designers have known for a long time: that design, and specifically, design thinking, assists in creative problem-solving and supports innovation in diverse fields. From scientific and medical research, software and app design to policy making and social planning, the value of design skills has been recognised and embraced globally. The skills that you develop during your Visual Communication Design studies can be applied to many areas of your academic and working life.

Some students choose to study Visual Communication Design because it provides a chance to build a folio for entry to a tertiary institution. Many visual art and design courses at TAFE and university level accept students after viewing a visual art folio during a preliminary interview. Keep in mind that many universities insist on good academic results as well as an impressive folio.

Studying Visual Communication Design during VCE can lead to many different study and career paths, some of which are listed below.









- + Advertising
- + Animation and motion graphics
- + Architectural drafting
- + Architecture
- + Cartography
- + Cartooning
- + Costume design
- + Education
- + Fashion design
- + Film making
- + Fine arts
- + Furniture design
- + Game design
- + Communication/Graphic design
- + Illustration
- + Industrial design
- + Interior architecture
- + Landscape architecture
- + Multimedia design and development
- + Printing
- + Photography
- + Publishing
- + Production design
- + Set/Theatre design
- + Signwriting
- + Textile design

- + Visual merchandising
- + Web design

It does not matter whether you choose to study Visual Communication Design to take a step towards a career in design, because it offers stimulation and challenges not found elsewhere in the curriculum, or simply because you like to draw. You have made your first move into a study that will change the way you view the world around you!

## HOW TO USE THIS BOOK

To assist you in using this book, icons are placed throughout to indicate the following:

-  **FYI**  
Information to read that may expand your interest in the topic
-  **Tip**  
Helpful information to assist in developing your skills
-  **Link**  
Websites that contain information that may assist your learning
-  **Video demo, video answer**
-  **Step by step**  
These show how to create particular types of drawing
-  **For example**  
This is like a mini case study
-  **Chapter recap**  
Activities based on learning within the chapter
-  **Smartphone revision cards**  
To help you revise for the exam  
Using your phone, log in to the student website for this book, click on 'Resources' and download the PDFs to use on the go.

# AREA OF STUDY NAVIGATOR

Unit	Area of Study	Use these chapters	Pages
Unit 1: Introduction to Visual Communication Design	Area of Study 1: Drawing as a means of communication	Chapter 1 2D and 3D drawing	pp. 3–42
		Chapter 2 Observational drawing and rendering	pp. 44–60
		Chapter 3 Visualisation and presentation drawing	pp. 62–66
		Chapter 7 Media, methods and materials	pp. 134–142
		Chapter 8 Design process	pp. 175–183
	Area of Study 2: Design elements and design principles	Chapter 3 Visualisation and presentation drawing	pp. 62–68
		Chapter 4 Purposes of visual communication	pp. 70–77
		Chapter 5 Design elements and design principles	pp. 79–112
		Chapter 7 Media, methods and materials	pp. 134–142
		Chapter 8 Design process	pp. 162–164, 175–190
		Chapter 9 Design thinking	pp. 205–216
		Chapter 11 Design fields	pp. 245, 259
	Area of Study 3: Visual communications in context	Chapter 13 Legal and ethical issues in design	pp. 289–292
		Chapter 12 Design in a wider context	pp. 262–285
	Unit 2: Applications of Visual Communication Design – Design Fields	Area of Study 1: Technical drawing in context	Chapter 1 2D and 3D drawing
Chapter 2 Observational drawing and rendering			pp. 48–60
Chapter 3 Visualisation and presentation drawing			pp. 64–66
Chapter 4 Purposes of visual communication			pp. 70–74
Chapter 10 Visual language and analysis			pp. 218, 223–225

Unit	Area of Study	Use these chapters	Pages
Unit 2: Applications of Visual Communication Design – Design fields	Area of Study 2: Type and imagery in context	Chapter 5 Design elements and design principles	pp. 79–112
		Chapter 6 Typography and layout	pp. 115–132
		Chapter 7 Media, methods and materials	pp. 134–158
		Chapter 9 Design thinking	pp. 206–216
		Chapter 10 Visual language and analysis	pp. 223–230
		Chapter 11 Design fields	pp. 245–255, 276–284
		Area of Study 3: Applying the design process	Chapter 4 Purposes of visual communication
	Chapter 5 Design elements and design principles		pp. 78–113
	Chapter 7 Media, methods and materials		pp. 134–139
	Chapter 8 Design process		pp. 161–191
	Chapter 9 Design thinking		pp. 206–216
	Chapter 13 Legal and ethical issues in design		pp. 287–294
	Unit 3: Visual Communication Design practices	Area of Study 1: Analysis and practice in context	Chapter 1 2D and 3D drawing
Chapter 3 Visualisation and presentation drawing			pp. 64–66
Chapter 4 Purposes of visual communications			pp. 70–75
Chapter 5 Design elements and design principles			pp. 78–113
Chapter 6 Typography and layout			pp. 117–121
Chapter 7 Media, methods and materials			pp. 133–159
Chapter 10 Visual language and analysis			pp. 218–227, 230–240
Chapter 11 Design fields			pp. 241–260



Unit	Area of Study	Use these chapters	Pages	
Unit 3: Visual Communication Design practices	Area of Study 2: Design industry practice	Chapter 8 Design process	pp. 160–203	
		Chapter 10 Visual language and analysis	pp. 218, 223, 230	
		Chapter 11 Design fields	pp. 241–260	
		Chapter 12 Design in a wider context	pp. 279, 284	
		Chapter 13 Legal and ethical issues in design	pp. 287–294	
	Area of Study 3: Developing a brief and generating ideas	Chapter 2 Observational drawing and rendering	pp. 47–60	
		Chapter 3 Visualisation and presentation drawing	pp. 62, 63, 66	
		Chapter 5 Design elements and design principles	pp. 78–112	
		Chapter 8 Design process	pp. 161–183, 190–200	
		Chapter 9 Design thinking	pp. 204–216	
		Chapter 10 Visual language and analysis	pp. 218–222, 231, 232	
		Chapter 13 Legal and ethical issues in design	pp. 287–296	
	Unit 4: Visual Communication Design development, evaluation and presentation	Area of Study 1: Development, refinement and evaluation	Chapter 3 Visualisation and presentation drawing	p. 67
			Chapter 5 Design elements and design principles	pp. 78–113
Chapter 7 Media, methods and materials			pp. 140, 152, 155	
Chapter 8 Design process			pp. 160–164, 175–192, 195–197, 201–203	
Chapter 9 Design thinking			p. 216	
Chapter 13 Legal and ethical issues in design			pp. 287–296	



PART A

**VISUAL  
COMMUNICATION  
DESIGN**

# 2D AND 3D DRAWING

CHAPTER

1

## In this chapter:

+ 3D drawing.....	3
» Paraline drawing.....	3
» Perspective drawing .....	9
» Circles and ellipses.....	20
» Drawing complex objects .....	21
+ 2D drawing .....	24
» Orthogonal drawing.....	25
» Packaging nets.....	36
» Two-dimensional drawing in environmental design .....	37
» Drawing elevations.....	39
» Landscape design.....	42

## Learn the language

angle	horizon	third-angle projection
crating	parallel	vanishing point
diameter	proportion	viewpoint
dimension	radius	views
elevation	scale	visual thinking

You will find helpful tasks related to drawing and rendering in Chapters 6 and 7 and throughout *Nelson Visual Communication Design VCE Units 1–4 Workbook, Edition Three*.

Drawing is at the very core of VCE studies in Visual Communication Design. Drawing enables us to communicate ideas and information. It takes many forms, from quick thumbnail sketches to visualise and convey a design concept to polished, rendered drawings, refined to show precise details.

Drawing entails its own language. Terms that refer to techniques, media and the materials used to execute a finished drawing are used by both designers and students of design.

Very simply, drawing is about 'mark making' – the placement of marks upon a surface that form together to create an image. The marks may be rapidly applied or executed in fine detail but they all strive to depict the qualities and characteristics of their subject.

Some techniques used in design drawing differ from those used when drawing in other contexts. Techniques applied by graphic designers, product designers, architects and interior designers vary according to the context and requirements of each drawing. In some instances, designers will use technical drawing methods to convey complex information about constructed and manufactured objects. In others, the use of freehand **sketching** and rendering may assist in communicating the form and structure

of a product. Software programs are also commonly used both to finish and enhance drawings, and to create drawings from scratch. Computer-rendered images create realistic representations of new products and constructions, and enable the viewer to see how a product may look.

## 3D DRAWING

Three-dimensional drawing more clearly represents how we see objects. We are accustomed to observing the length, width and depth of objects.

### PARALINE DRAWING

**Paraline drawings** are constructed of lines that remain parallel and do not converge at any given point. Paraline drawing is a straightforward method of representing the three-dimensional form of an object. As shown in the diagram below, the main paraline drawing methods covered in the Visual Communication Design course are isometric and planometric drawing.

#### Paraline

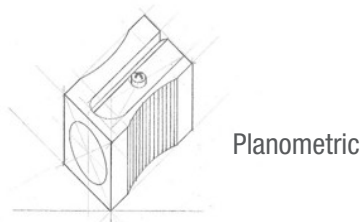
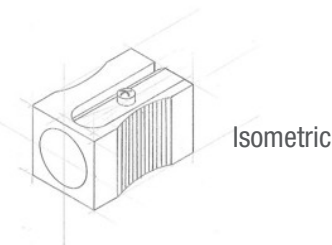

#### Perspective

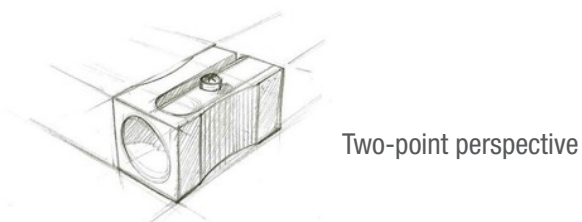

## Isometric drawing

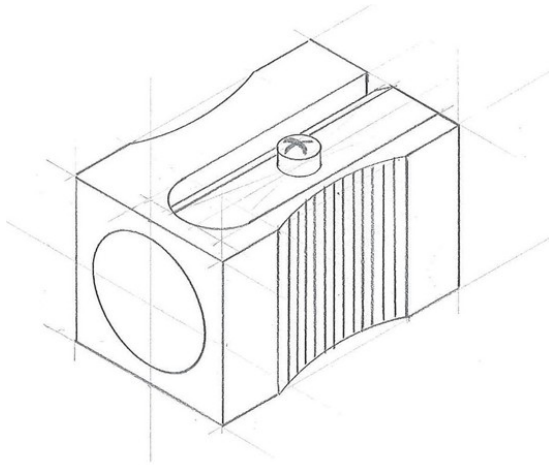

**Isometric drawings** are popular three-dimensional drawings because of their relatively simple construction. Isometric drawings are quicker to draw than two-point perspective ones, yet look somewhat similar and may provide similar information. In an isometric drawing the height (or corner) of the object faces the viewer, and the width and depth of the object recede (remaining parallel) at 30°.

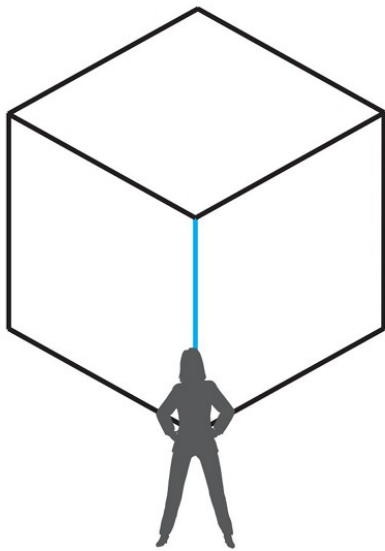

▲ Viewer position: isometric drawing

Isometric drawings are frequently used in product design where it is important to show as much detail as possible about the object or product using a three-dimensional representation. Isometric drawing allows a designer to depict the form and details of an object in a manner that conveys true **proportions**.

Isometric drawings are commonly applied in technical drawings in addition to orthogonal representations. Drawings of engineering components and the like sometimes include a three-dimensional version of the object in isometric as well as two-dimensional technical drawings to provide detail about the appearance of a completed product or part.

### TIP: ISOMETRIC GRID PAPER



You might find it helpful to draw your isometric drawings on isometric grid paper which is pre-drawn with 30° and 90° lines.

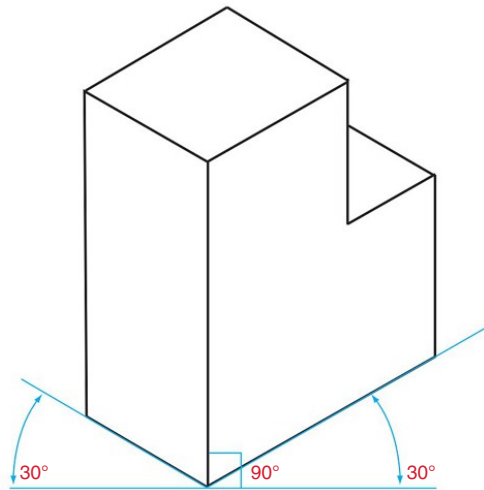

▲ Isometric drawing

## A STEP-BY-STEP GUIDE TO ISOMETRIC DRAWING



**Step 1:** Begin by drawing the height of the object facing you. This will be at  $90^\circ$ .

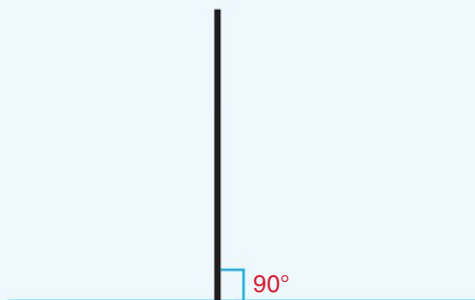

**Step 2:** Using a  $30^\circ$  set square, draw two  $30^\circ$  lines at the base of the vertical height line.

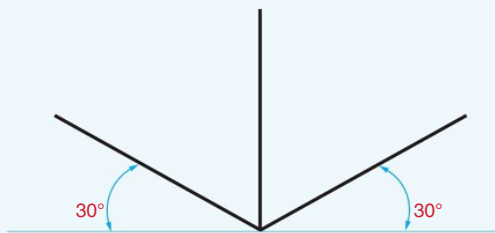

**Step 3:** Measure and indicate the length of the object on the  $30^\circ$  lines and the height of the object on the vertical line.

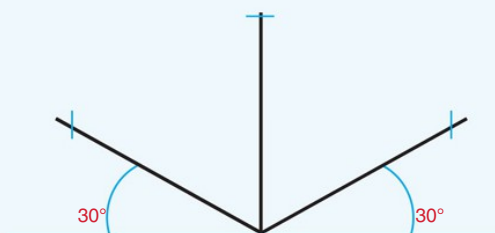

**Step 4:** Draw vertical lines from the  $30^\circ$  lines and measure and indicate the height.

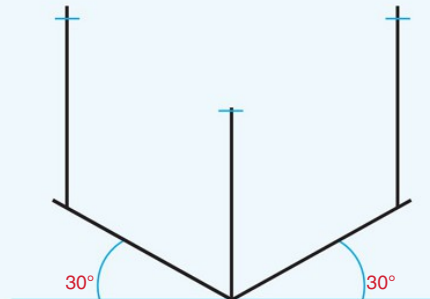

**Step 5:** Draw  $30^\circ$  lines from the top of the vertical line.

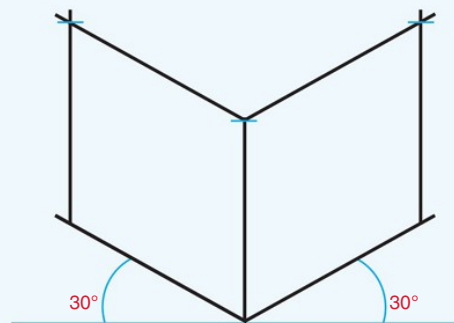

**Step 6:** Draw  $30^\circ$  lines parallel to the base of the object to complete the top. Erase any excess lines to tidy the drawing.

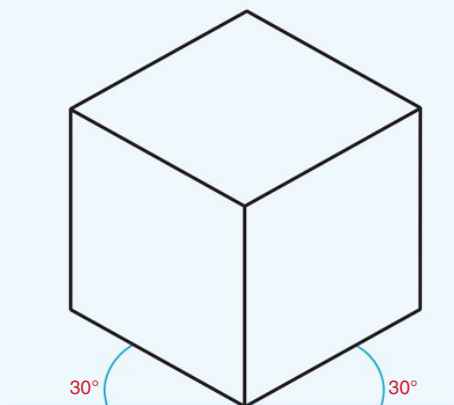

### Isometric exploded view

An exploded **view** of an object is generally used to indicate the parts that make up a design product. An exploded view is most often drawn in isometric and shows all parts in alignment to one another. The value of an exploded view is that it enables the viewer to clearly visualise the placement of parts of an object; it can represent aspects of an object that may be hidden from view when shown in an alternative drawing method.

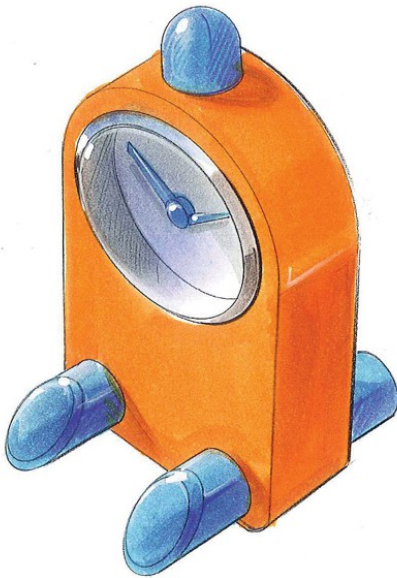

▲ Isometric view of an alarm clock

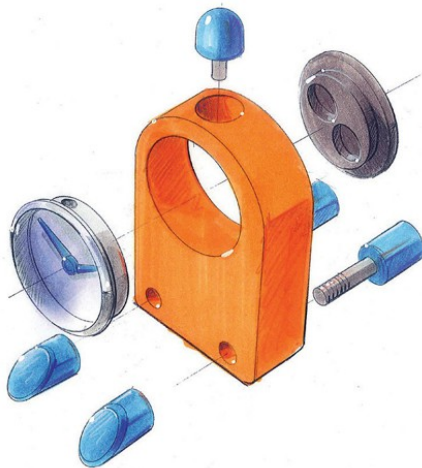

▲ Exploded isometric view of an alarm clock

Exploded views are often seen on assembly drawings in industrial design. Parts and materials are indicated on the drawing and in a table. Different representations of the object, such as orthogonal views, are usually included to assist in assembly and production.

### Planometric drawing

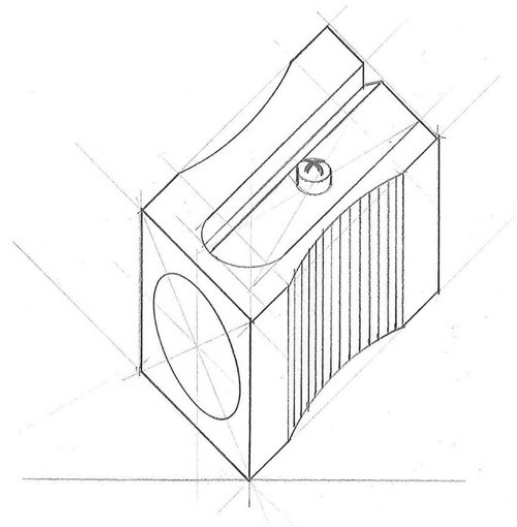

**Planometric drawings** are similar in their construction to isometric drawings, but the length and depth of the object is drawn at 45°. The height of the planometric object faces the viewer and all sides recede at 45°. The **elevation** of 45° gives the viewer a 'bird's-eye' view of features while retaining three-dimensional qualities.

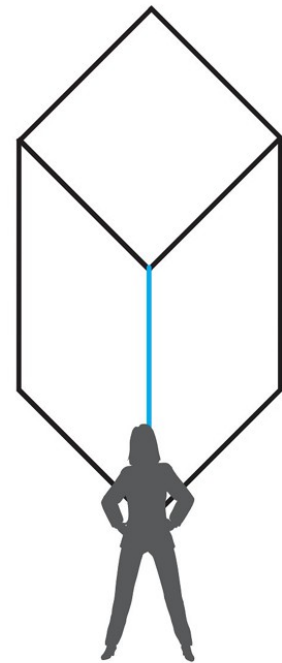

▲ Viewer position:  
planometric drawing

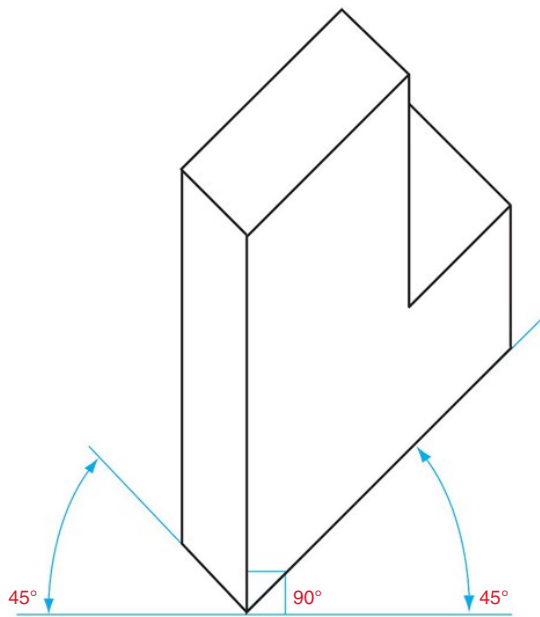

▲ Planometric drawing

### A STEP-BY-STEP GUIDE TO PLANOMETRIC DRAWING



**Step 1:** Begin by drawing the height of the object facing you. This will be at 90°.

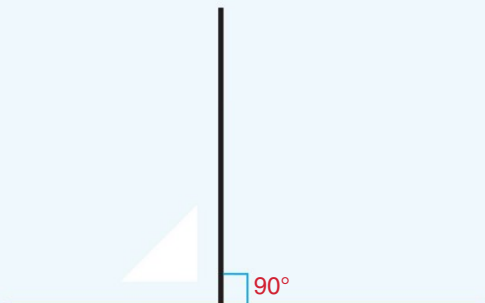

**Step 2:** Using a 45° set square, draw two 45° lines at the base of the vertical height line.

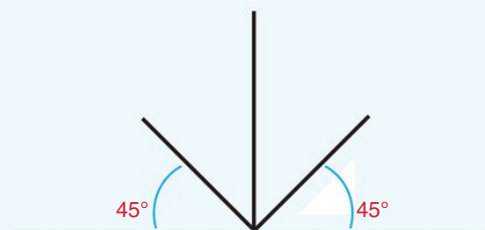

**Step 3:** Measure and indicate the length of the object on the 45° lines and the height of the object on the vertical line.

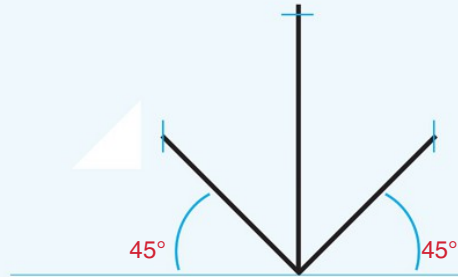

**Step 4:** Draw vertical lines from the 45° lines and measure and indicate the height.

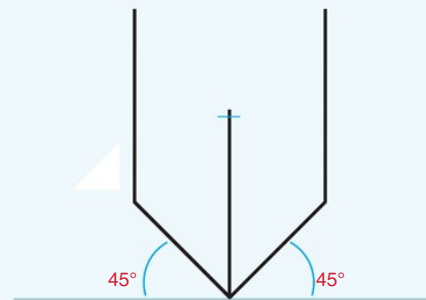

**Step 5:** Draw 45° lines from the top of the vertical line.

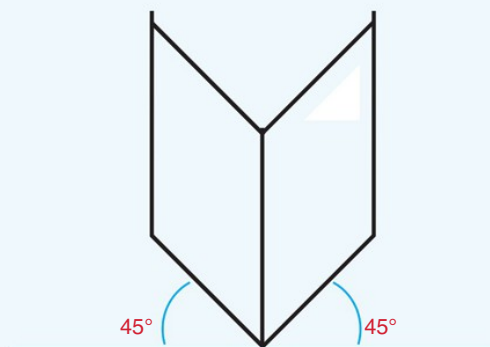



**Step 6:** Draw 45° lines parallel to the base of the object to complete the top. Erase any excess lines to tidy the drawing.

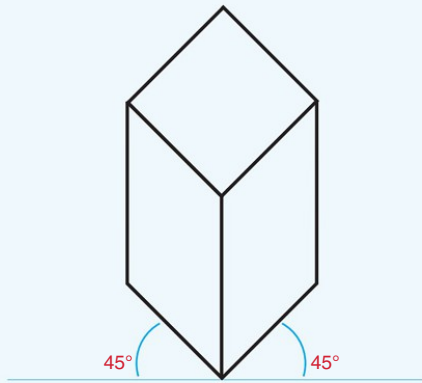

### Planometric drawing in environmental design

In architectural illustration, planometric drawing is often used to create a three-dimensional representation of a two-dimensional floor plan. When drawing the interior detail of a building or object, the 45° angle allows for an exaggerated **viewpoint**.

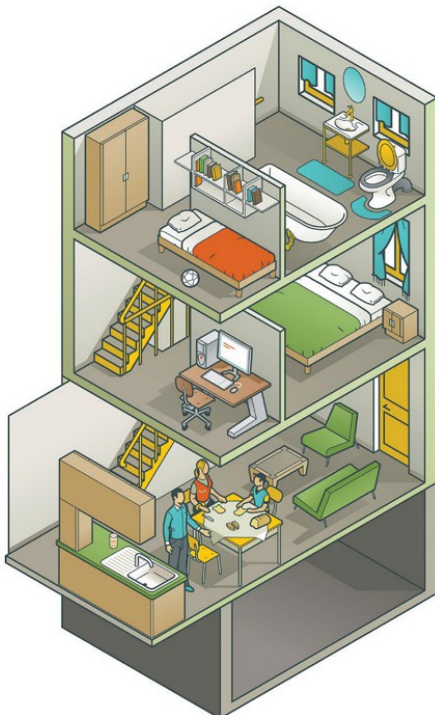

Tom Grech

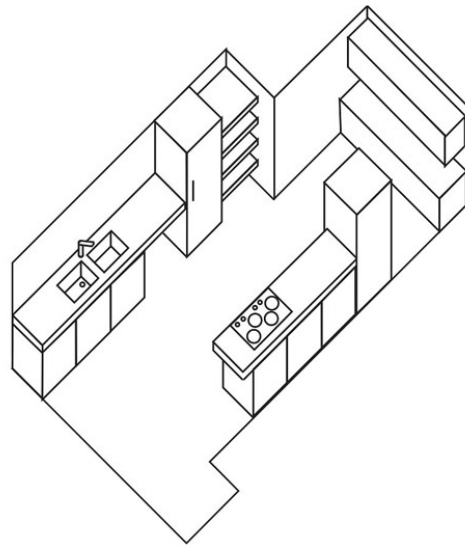

### A STEP-BY-STEP GUIDE TO CREATING A PLANOMETRIC DRAWING FROM A FLOOR PLAN



**Step 1:** Start with a two-dimensional floor plan.

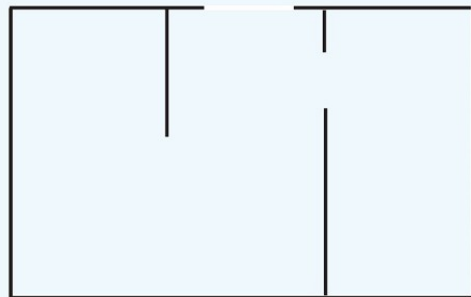

**Step 2:** Begin by rotating the plan to 45°.

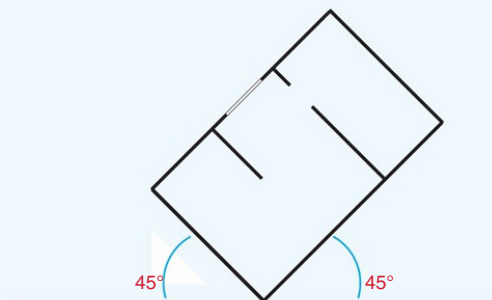

**Step 3:** Project vertical lines from the base of each detail or feature on the plan.

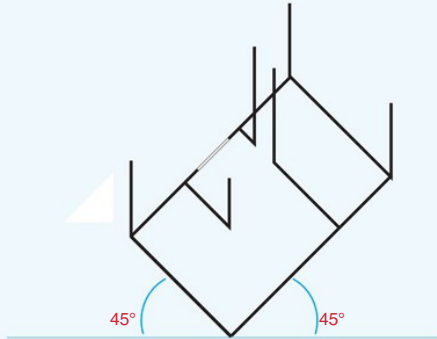

**Step 4:** Complete the features by drawing 45° lines parallel to the original lines on the plan.

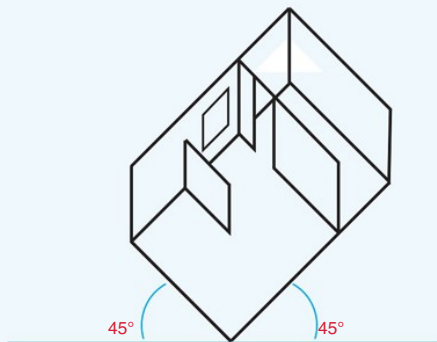

## PERSPECTIVE DRAWING

**Perspective drawing** closely reflects the way that the human eye perceives an object in space. When we see an object, our brain tells us that the object gets smaller as it recedes into space. We know for a fact that isn't true but it is what our eye sees. We have an innate understanding of this phenomenon as representing depth and distance.

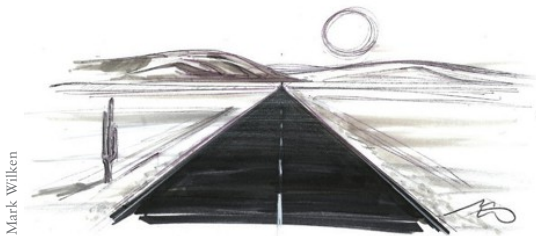

Mark Wilken

ISBN 9780170401784

A long, straight highway is a good example of the perspective phenomenon. A road seems to narrow as it heads towards the **horizon**. However, if you were to travel along the road, it would be clear to you that the road does not diminish in size. You might also notice that any houses, trees and power poles along the sides of the road also appear to diminish in size as they recede into the distance.

When drawing in perspective, the principles are the same. A row of objects drawn facing the viewer represents just that – a row. Redraw the same objects so that they appear to diminish in size, approaching a point on the horizon, and you have a composition that implies depth as well as representing the form and detail of the objects themselves.

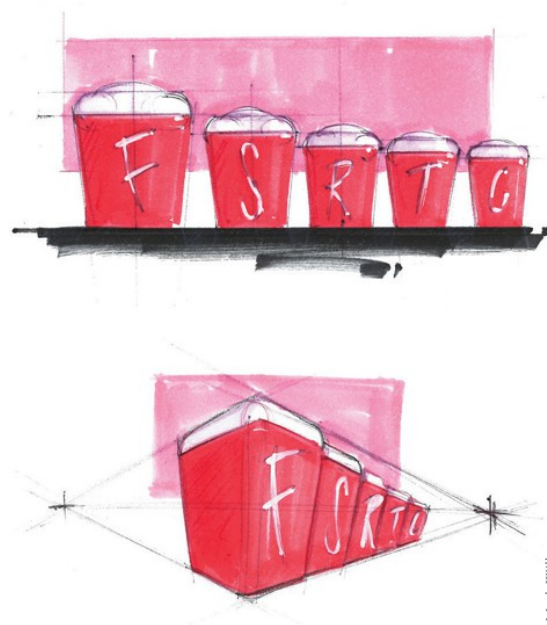

Mark Wilken

Interestingly, it is not only the shape and form of objects that appear to change when drawn in perspective. Colour changes also occur when an object appears to recede into the distance. You have probably noticed that when you observe a city skyline from a distance, the buildings seem to be a uniform grey, when in fact they may be a range of colours from dark brown to metallic silver to white.

Nelson Visual Communication Design VCE Units 1–4



Mark Wilken

▲ In perspective drawing, colours and tones are less distinct as they move into the distance.

## EXPEDIT

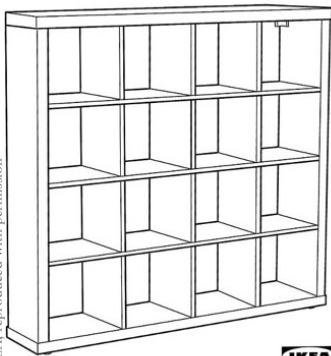

© IKEA, reproduced with permission



## KARLSTAD

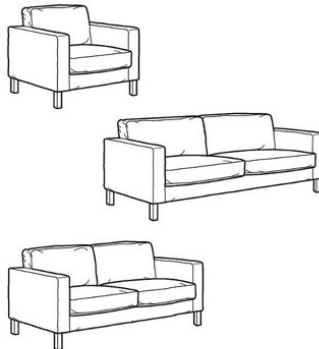

## IKEA/PS

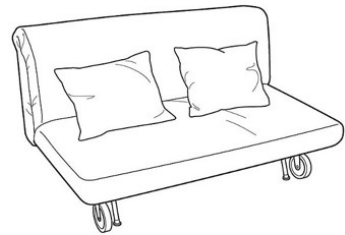

▲ Perspective drawing in context: Ikea uses simple perspective line drawings to display their merchandise. Along with the company's simple and iconic step-by-step visual instructions, these representations of their product line have become a distinctive part of the company's brand.

## Establishing your point of view

When drawing in perspective, your first task is to visualise what it is you want to represent. Ask yourself: What are the important features of the object I wish to illustrate? What is the key information about this object that I want to convey to the viewer? This will help you to plan the 'point of view' of the object; that is, the position from which you plan to draw it.

In any perspective drawing, the placement of the object in relation to the horizon line will affect the point of view of the depicted object.

The horizon line sits at the level of the viewer's eyes. This is called eye level. An object placed below the horizon line – below eye level – will give more

information about the top of the object. Place the object above the horizon line, and then the area underneath the object becomes most obvious. If you place your object directly on the horizon line, the 'point of view' will appear to be quite realistic, as it sits at eye level. Again, it all depends on the effect you wish to create.

The most common methods of perspective drawing are one-point perspective and two-point perspective. Three-point perspective is sometimes used in illustrations where a dramatic and exaggerated representation is required. In the Visual Communication Design course, you are required to develop skills in both one-point and two-point perspective.

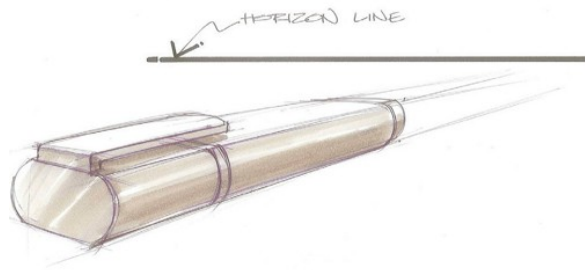

- ▲ An object that is drawn below the horizon line offers information about the top of the object.

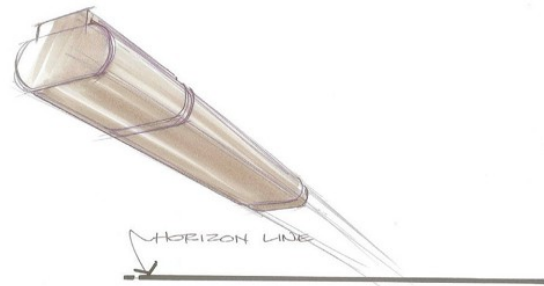

- ▲ An object that is drawn above the horizon line offers information about the base of the object.

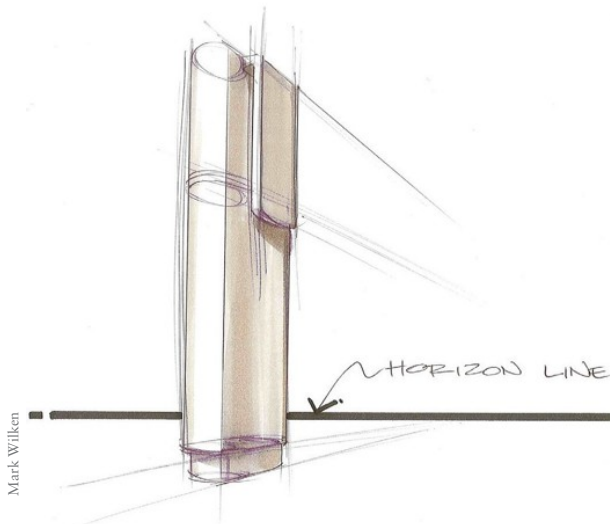

- ▲ An object that is drawn on the horizon line offers information about the front of the object.

## One-point perspective

In one-point perspective, the height and width of the object faces the viewer. Remember the following key concepts when drawing in one-point perspective:

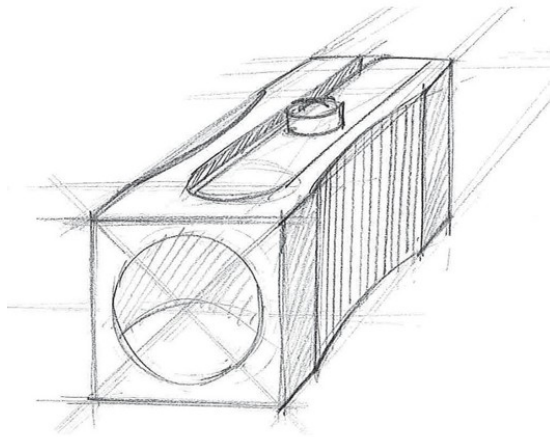

- + The height and width of the object face the viewer.
- + All depth (or the sides of the object) recedes to one point on the horizon line.

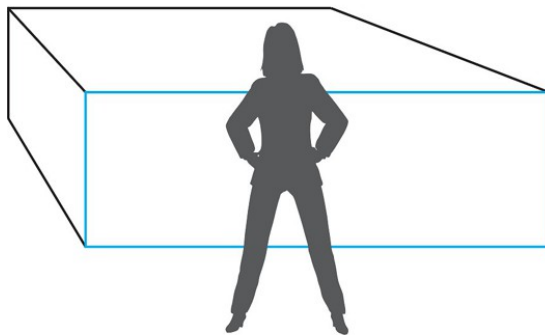

▲ Viewer position: one-point perspective drawing

One-point perspective is sometimes referred to as linear perspective. In one-point perspective an entire plane of an object faces the viewer.

The impression of a road receding to a point on the horizon is one-point perspective.

One-point perspective is a method evident in many depictions of landscapes and interiors.

A perspective box is a simple way to begin working with this three-dimensional drawing method. Once you can draw a perspective box effectively, you can draw just about anything!

## A STEP-BY-STEP GUIDE TO ONE-POINT PERSPECTIVE



**Step 1:** Decide on the position of the object in relation to eye level and draw a horizon line.

Horizon line

**Step 2:** Begin with the height and width of the object facing you. Your page acts as the picture plane (or surface area upon which the object is placed). The height and width of the drawn object should be parallel to the height and width of your page.

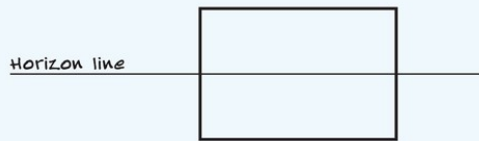

**Step 3:** Decide on the angle of view you wish to represent, and place the **vanishing point** appropriately to the left, right or in the centre. Do you want to depict more of one side? Do you want to depict the front only?

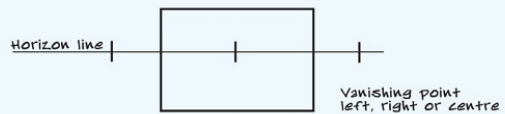

**Step 4:** Draw light projection lines from the corners of the object to the vanishing point.

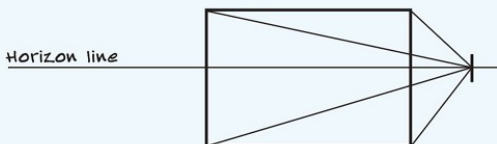

**Step 5:** Decide on the appropriate depth of the object in perspective, and draw horizontal and vertical lines within the projection lines to complete the back of the box. Making a decision about the size of the object will take some practice and require the application of your visualisation skills. Your aim is to create an image that has realistic proportions. Erase the light projection lines.

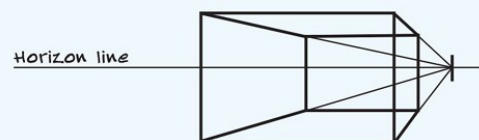

### One-point perspective interior

One-point perspective represents the way the human eye sees simple interiors. Once you are able to draw simple geometric shapes in perspective, you can then

add details to form highly descriptive illustrations. One-point perspective is particularly useful when illustrating interiors.

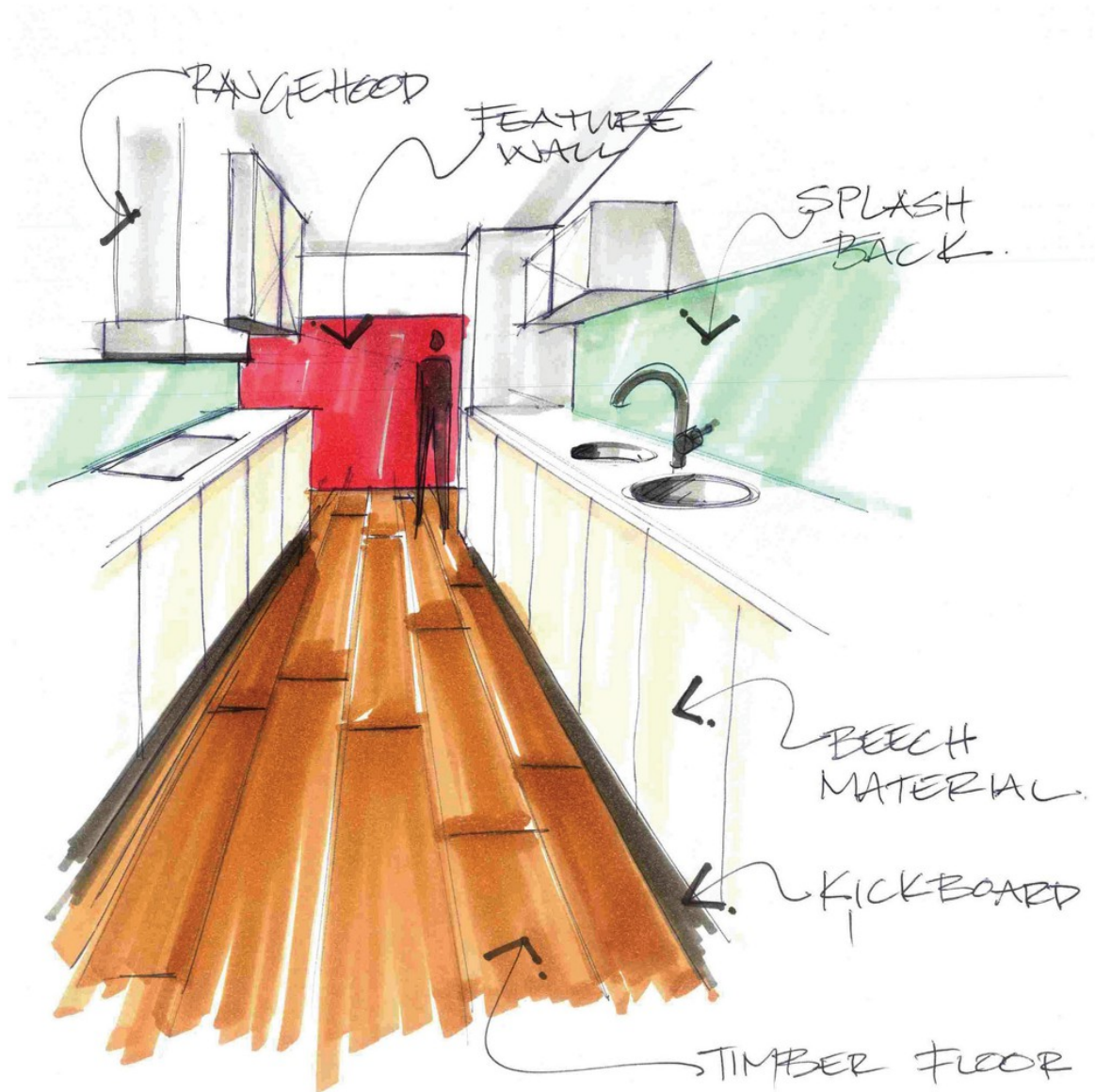

## A STEP-BY-STEP GUIDE TO DRAWING AN INTERIOR



**Step 1:** Construct a box as illustrated previously – but this time, project lines from the left and right front corners of the box.

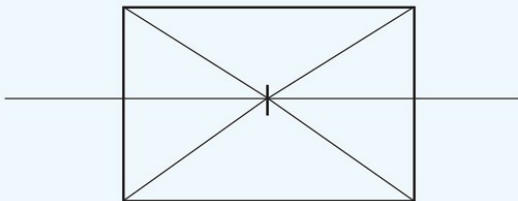

**Step 2:** Draw vertical lines from the back corners of the box to form the rear wall of the room or object.

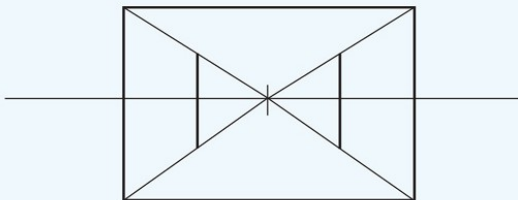

**Step 3:** Draw a horizontal line to form the base of the back wall.

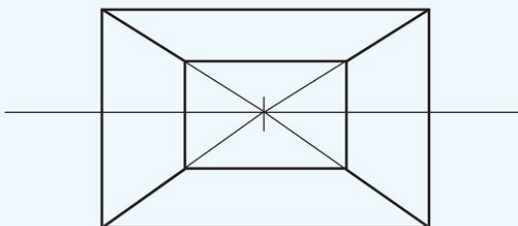

**Step 4:** You now have an empty box to which detail can be added to create any number of possibilities. Any object you create within the interior must recede to the vanishing point.

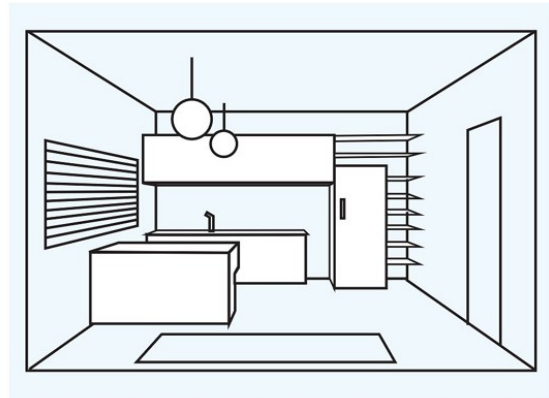

## Two-point perspective

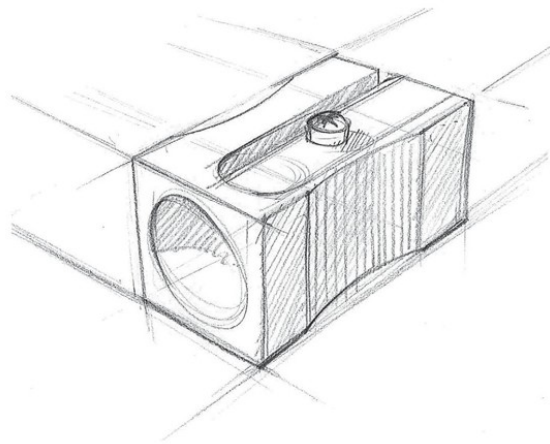

In two-point perspective, only the height faces the viewer, and the depth or sides of the object recede to two vanishing points on the horizon line. Two-point perspective is sometimes referred to as angular perspective.

Key concepts to remember when drawing in two-point perspective are:

- + The height of the object faces the viewer.
- + All other **dimensions** recede to two points on the horizon line.

If you stand outside your house, or even outside one of your school buildings, you will become aware that the sides of the buildings recede, ever so slightly, to separate vanishing points.

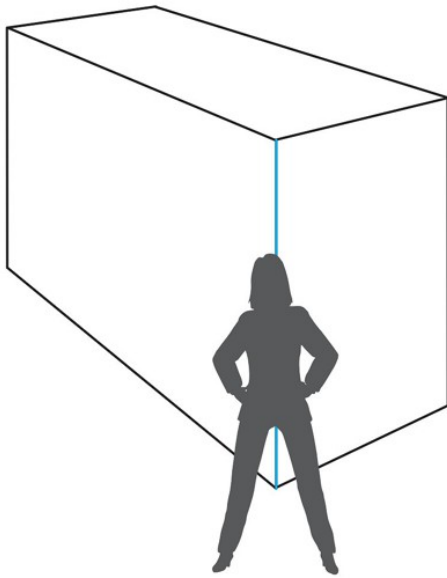

▲ Viewer position: two-point perspective drawing

### A STEP-BY-STEP GUIDE TO TWO-POINT PERSPECTIVE



**Step 1:** Begin by making a decision about where eye level will be on your drawing. Draw the horizon line.

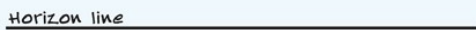

**Step 2:** Draw the desired height of the object.



**Step 3:** Draw vanishing points to the left and right of the height line on the horizon line. Remember, the further apart the vanishing points, the less extreme the perspective will appear to be.



**Step 4:** Draw light lines from the corners of your height line to the vanishing points.

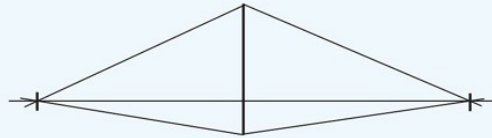

**Step 5:** Make a decision about the appropriate length for your object and add vertical lines to complete the sides of the object.

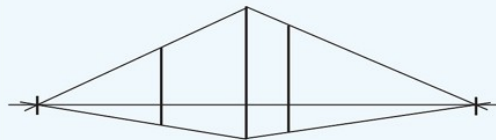

**Step 6:** Draw the two lines that will complete the top of the object by projecting lines from each of the lines that form the sides.

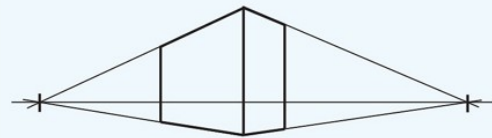

**Step 7:** Details can be added to a simple two-point perspective drawing to create a more detailed illustration.

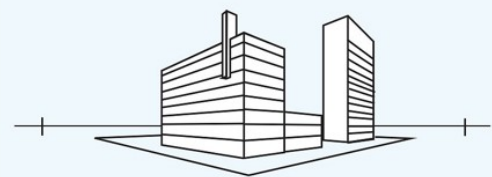

In the field of environmental design, Two-point perspective is widely used for both exteriors and interiors.





▲ Two-point perspective drawing of an architectural exterior

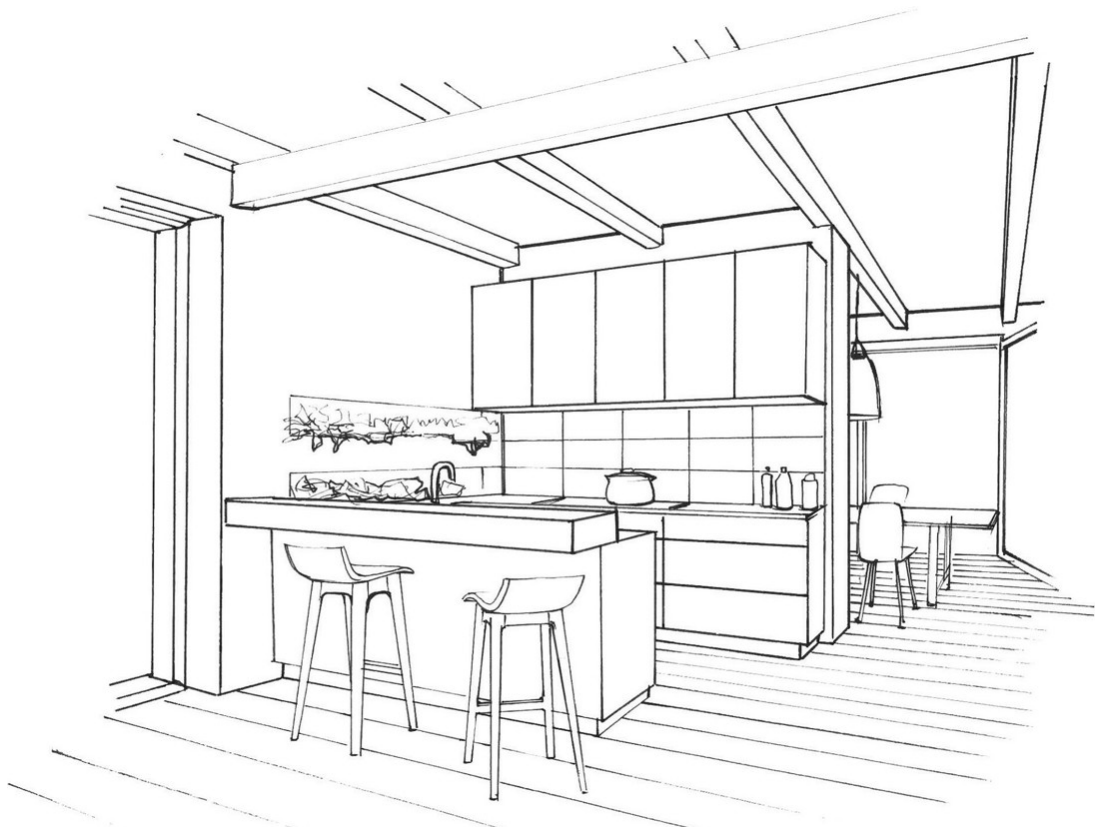

▲ Two-point perspective drawing of an architectural interior. For more information on creating complex and rounded objects in perspective, see 'crating techniques' on page 22.

In environmental design, you may need to create a three-dimensional view of a two-dimensional drawing, such as a floor plan.

### A STEP-BY-STEP GUIDE TO DRAWING TWO-POINT PERSPECTIVE FROM A PLAN



**Step 1:** Draw a horizontal line and label it picture plane. Place the plan view on the picture plane at 45°.

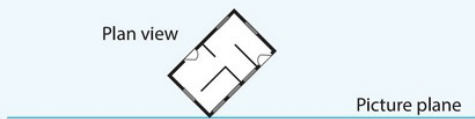

**Step 2:** Place the elevation view to the right of where the perspective will be and draw a horizontal ground line.

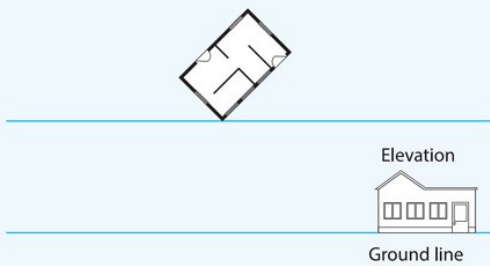

**Step 3:** Place a viewing point at the most appropriate level to 'view' the drawing. Draw light project lines from each corner of the plan to the viewing point. Don't place the viewing point too close to the ground line or the drawing will become distorted.

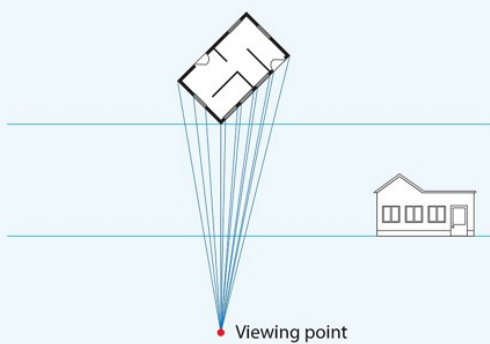

**Step 4:** Draw a mark where the projection lines intersect with the picture plane (projection lines can now be erased to keep things simple).

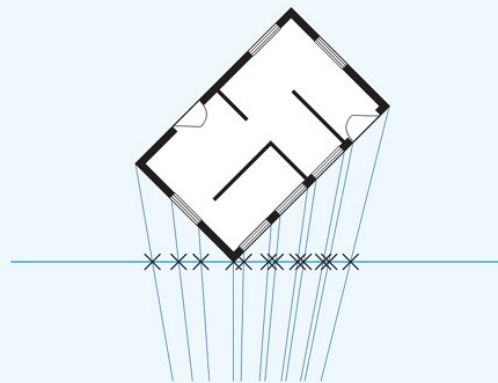

**Step 5:** Using the marks you just made, draw vertical lines to the ground line to establish the exterior dimensions of the structure.

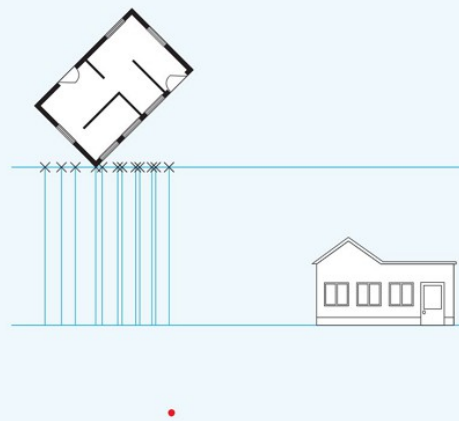

**Step 6:** Create a horizon line in line with the centre of the elevation. You can vary the position of the horizon line depending on the angle of view you wish to draw.

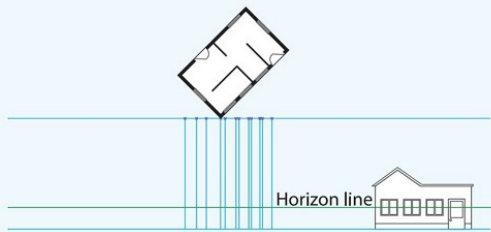

**Step 7:** From the viewing point draw lines that remain parallel to the edges of the plan view.

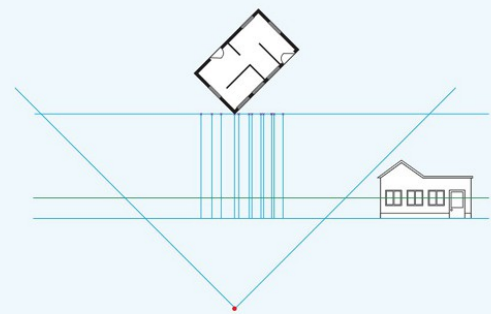

**Step 8:** Where these lines intersect with the picture plane, draw a vertical line down to meet the horizon line and establish each vanishing point.

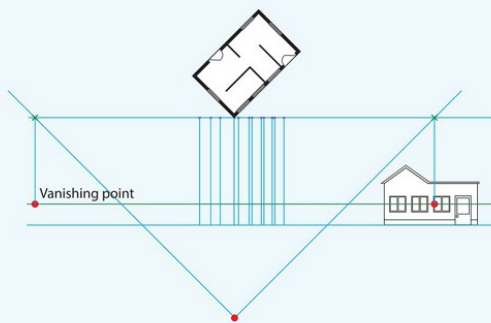

**Step 9:** Using the elevation to determine the height of features, create vertical lines to represent the wall and roof heights.

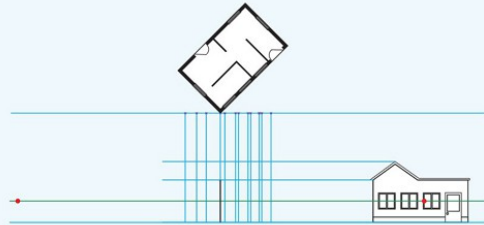

**Step 10:** Project lines to the vanishing points as per the two-point perspective drawing method to complete the structure.

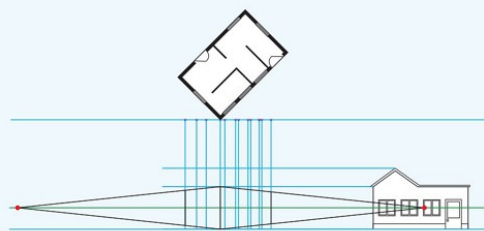

**Step 11:** Using the projected lines from the plan and elevation views, complete the details such as windows, doors, roofline, etc.

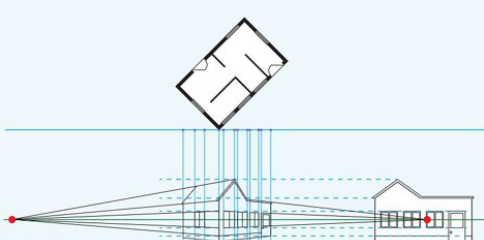

## Shadows in perspective

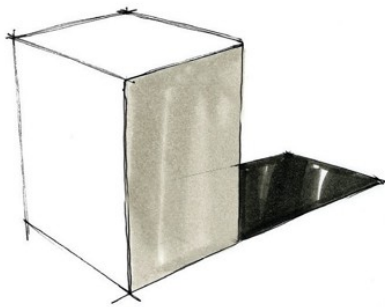

When rendering perspective drawings it is helpful to include elements that create realism; a cast shadow is one such element. The application of a shadow can give an object context and emphasise its **scale** and volume.

In perspective, constructing a shadow involves projecting a shape onto a surface. The rules of each perspective method apply.

### STEP-BY-STEP GUIDE TO SHADOWS IN TWO-POINT PERSPECTIVE



● Light source

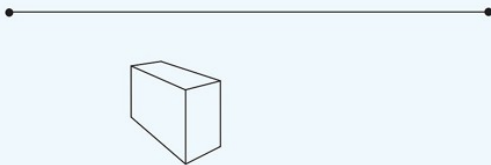

**Step 1:** Establish a light source. This will direct the type of shadow you wish to apply.

● Light source

● Shadow vanishing point

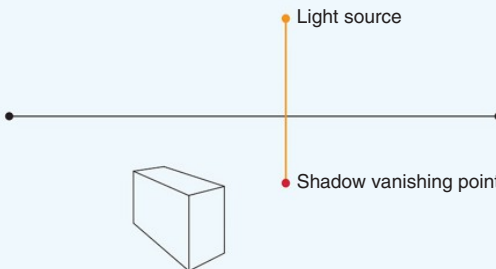

**Step 2:** Establish a 'shadow vanishing point'. This sits directly below the light source, behind the perspective object and in line with a relevant vanishing point.

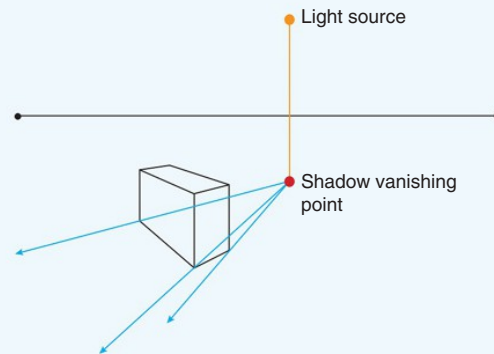

**Step 3:** Project lines from the shadow vanishing point via the bottom corners of the object where the shadow will be cast.

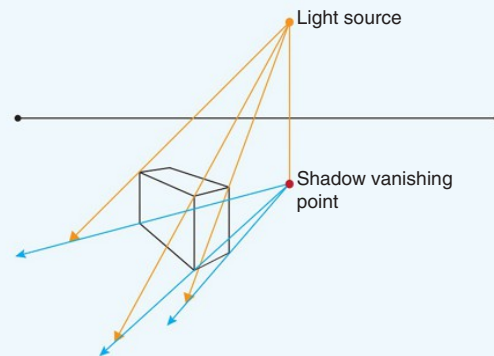

**Step 4:** Project lines from the light source via the top corners of the perspective object.

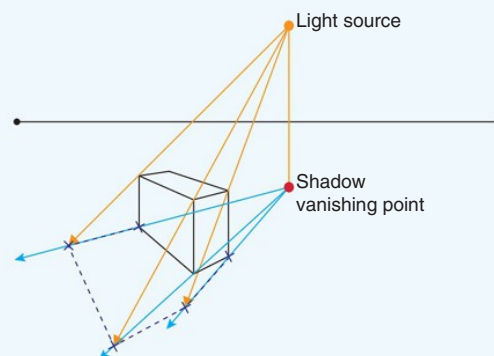

**Step 5:** Where the light source lines intersect with the shadow vanishing point lines, draw connecting lines.

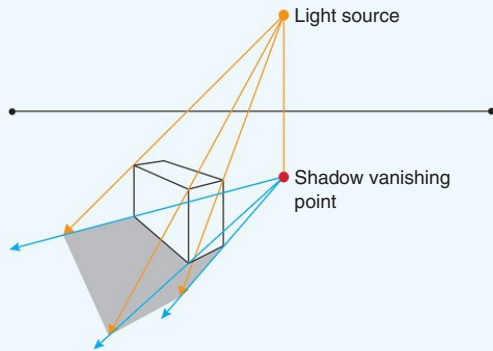

**Step 6:** The connected points form the shadow. Render as required.

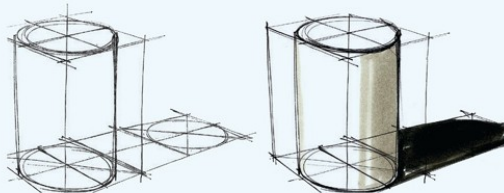

▲ When creating a shadow on a cylindrical or rounded object, use an ellipse to create the rounded edge of the shadow.

## CIRCLES AND ELLIPSES

When a circle is viewed in perspective or as part of a paraline drawing, it appears as an ellipse. Depicting circular details in three-dimensional drawing can be quite a challenge but, with practice, will become intuitive. The more you draw ellipses, the easier it becomes to create them in your visualisation and presentation drawings.

An ellipse is made up of two axes: a major axis and a minor axis. The major and minor axes are formed when a circle is drawn in perspective or paraline form.

### VIDEO DEMO: ELLIPSES

Learn how to draw ellipses. Go to <http://nelsonnet.com.au> and use the code at the back of your book to log in. Click on 'Resources', then go to Chapter 1, page 20 video.

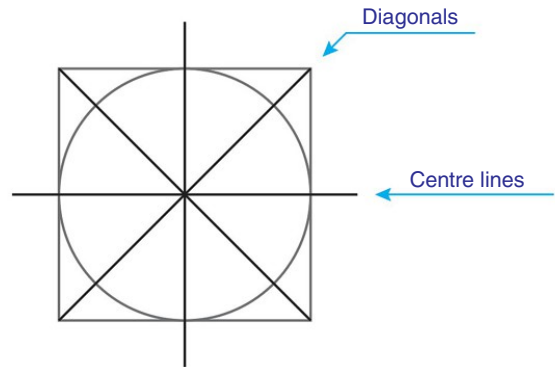

▲ A circle sits within a square at 90°. The circle features centre lines and diagonal lines; these lines assist in creating an ellipse.

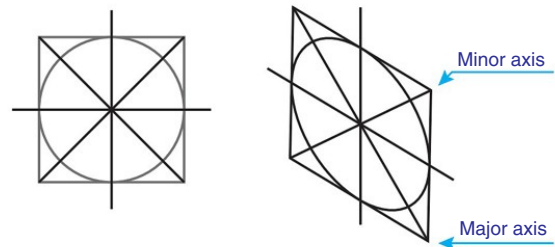

▲ The rotation of the square to 30°(isometric) means that the diagonal lines create a major (long) axis and minor (short) axis. This directs the appearance of the ellipse.

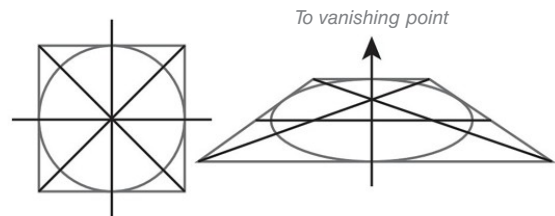

▲ A one-point perspective ellipse. Notice that the centre of the ellipse does not coincide with the intersection of centre lines. This is due to perspective **foreshortening**.

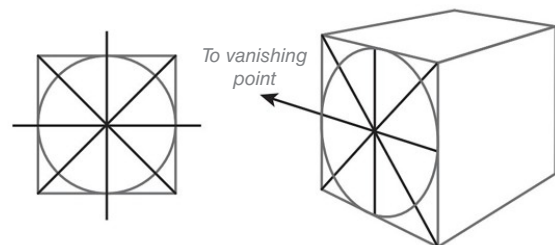

▲ The same principles apply in two-point perspective. The centre lines refer to the vanishing points.

## Isometric ellipses

When drawing isometric ellipses you should become familiar with a very helpful piece of equipment: the standard isometric ellipse template. Such a template enables you to draw accurate ellipses. When larger ellipses are required, it is possible to construct them manually using segments of a circle, known as arcs.

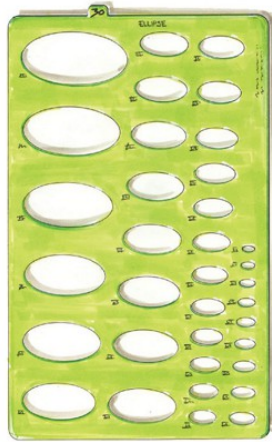

Mark Wilken

Ellipses are used when developing images such as cylinders, spheres and tubular features. The combination of ellipses creates complex forms.

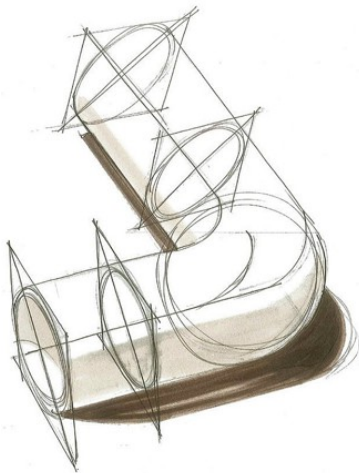

▲ Ellipses can be used in combination to form rounded and cylindrical objects.

## DRAWING COMPLEX OBJECTS

An effective method of drawing complex three-dimensional forms is by using the **crating** or boxing technique. This technique involves using basic geometric forms as the foundation for constructing complex objects. There are four basic three-dimensional forms: the sphere, the cone, the cylinder and the cube.

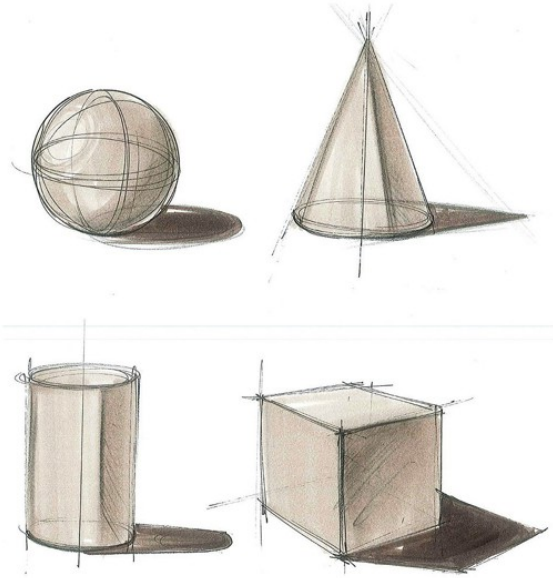

Many objects are made up of variations of these four basic forms. A bottle is a series of cylinders. A wine glass is formed by a partial sphere and cylinder. A compact camera is a combination of cubes and cylinders.

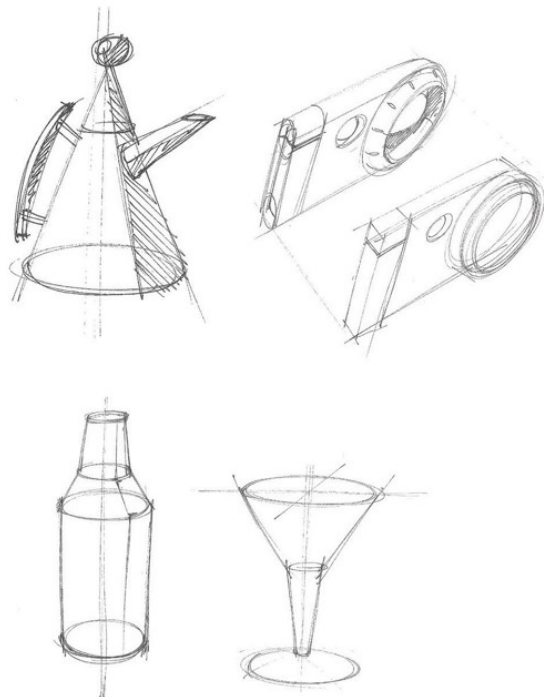

## Drawing curves

Curved details on objects can be created by ellipses. The **radius**, or curved edge of the ellipse, touches the end of a straight line (or tangent). In freehand visualisation drawing, the use of ellipses to form radii or varying dimensions adds realism and emphasises complex, interesting forms.

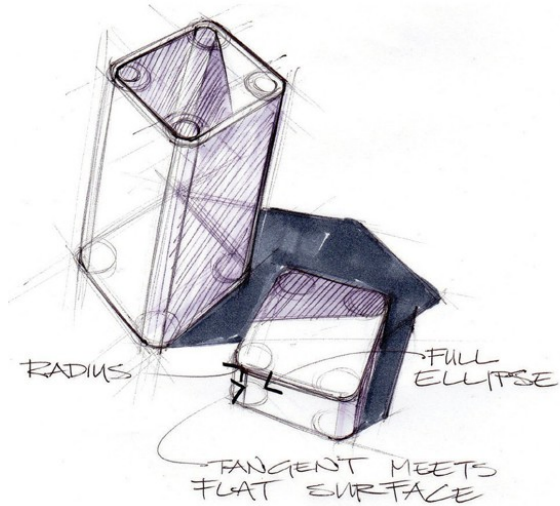

## Using the crating technique

Crating is a drawing method that utilises the basic form of an object as a skeletal structure around which the finished form can be created. When an object is broken down into its most basic shape combinations, realistic proportion and scale can be established.

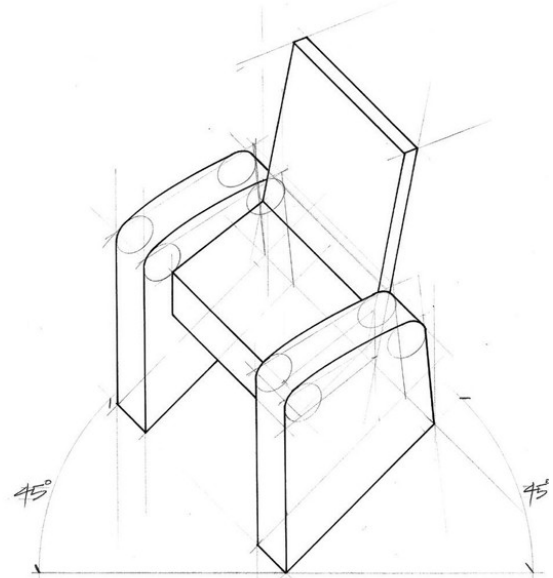

▲ Planometric drawing of club armchair using crating method



▲ Once you understand the technique of drawing curves and crating, objects take on greater realism.

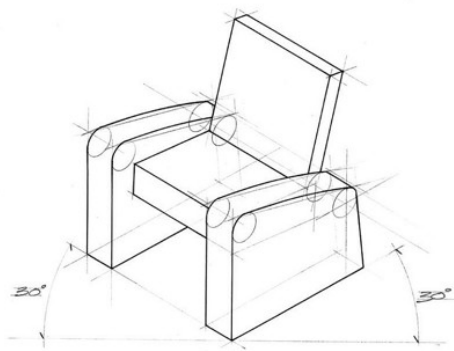

▲ Isometric drawing of club armchair using crating method

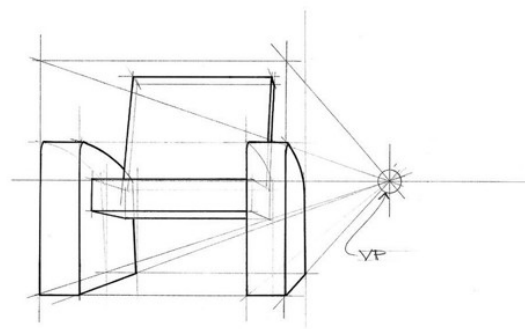

▲ One-point perspective drawing of club armchair using crating method

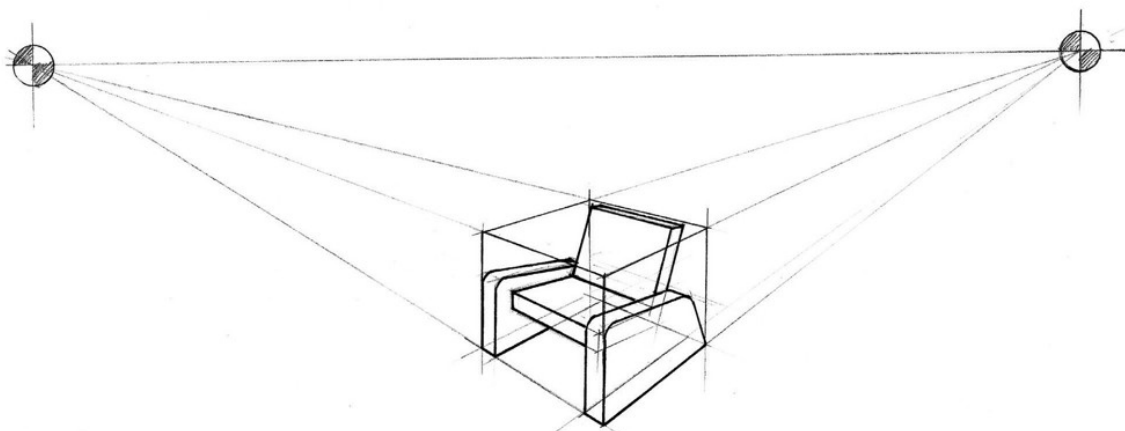

▲ Two-point perspective drawing of club armchair using crating method

**TIP: DIVIDING PERSPECTIVE OBJECTS**



To divide perspective objects, divide the plane of the object by using diagonal lines. Where those lines intersect is the centre of the plane.

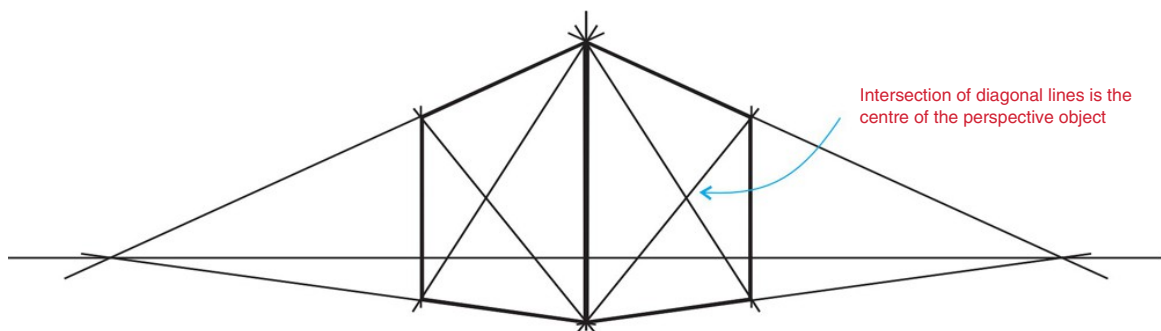

Intersection of diagonal lines is the centre of the perspective object



# 2D DRAWING

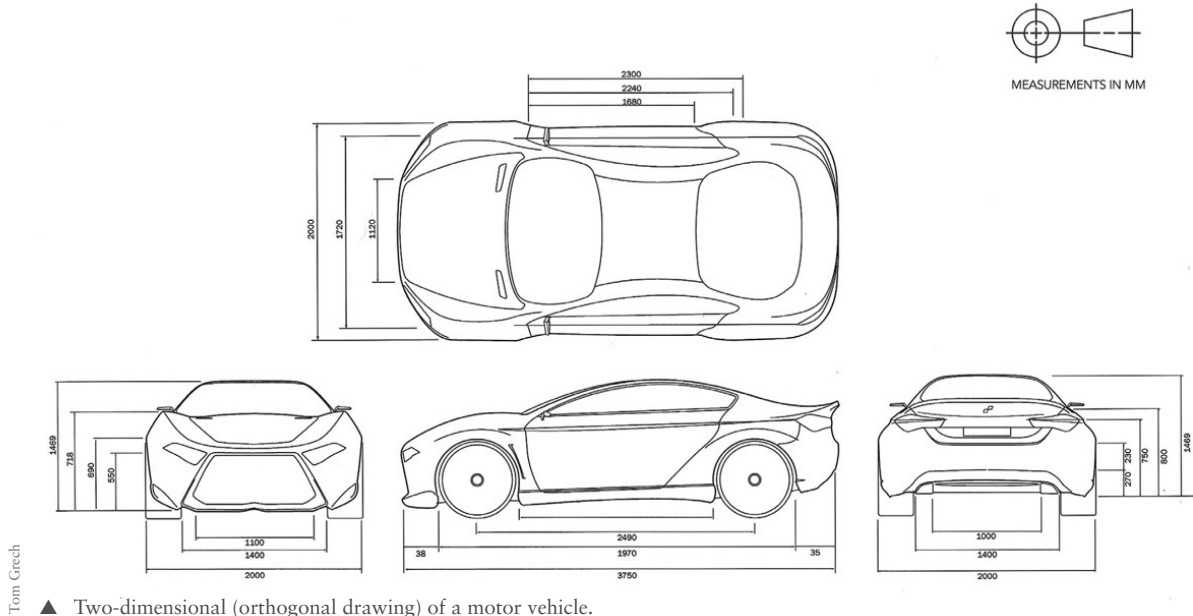

▲ Two-dimensional (orthogonal drawing) of a motor vehicle.

An industrial designer needs to produce clear technical drawings so that an engineering firm can manufacture their product. It is also necessary for the designer and the engineer to speak the same technical language, so that the product can be manufactured successfully.

Over many years, as the information conveyed in technical drawings has become more complex, a universal technical language has evolved. Using recognised standards and conventions established by a regulatory body, it is possible for the visual information and ideas, concepts and finished designs to be clearly understood throughout the world.

### TIP: STANDARDS

In Australia, the organisation Standards Australia provides handbooks and guidelines for professionals and students outlining Australian technical drawing practice. The Victorian Curriculum and Assessment Authority (VCAA) publishes Technical Drawing Specifications that can be accessed on the VCAA website. For VCE studies in Visual Communication Design, it is recommended that you have access to the VCAA guidelines.

### LINK: TECHNICAL DRAWING

To further your interest and knowledge of technical drawing the current Standards Australia handbook *Technical Drawing for Students (SAA/ SNZHB1:1994)* is available for purchase online.

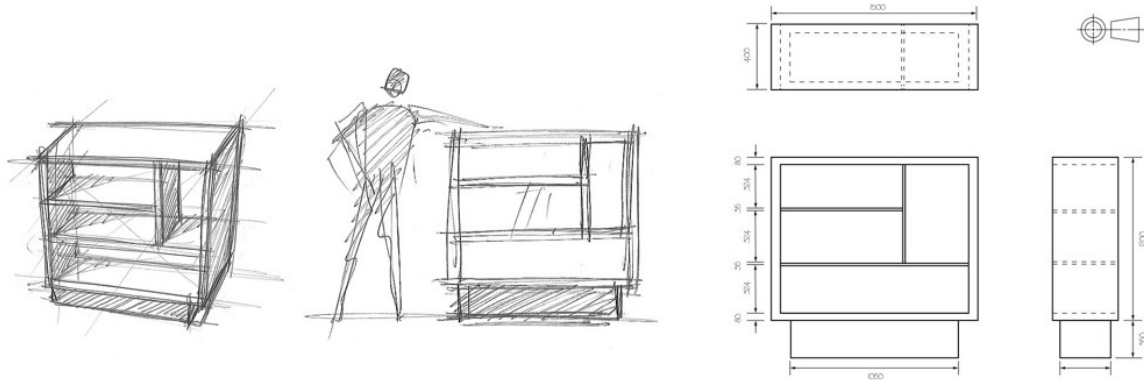

Two-dimensional drawings provide a clear means of communicating information about the appearance, assembly, function or construction of an object using multiple views of its form and structure. Two-dimensional drawing can be a test of your **visual thinking** skills, as to draw an object that you perceive as having three dimensions (height, width and depth) in only two dimensions (height and width) can be challenging.

A two-dimensional drawing may be used at various stages of a design process; as freehand sketches of views of the object in order to explain the design concept, or as a finished technical drawing with dimensions and section view included.

## ORTHOGONAL DRAWING

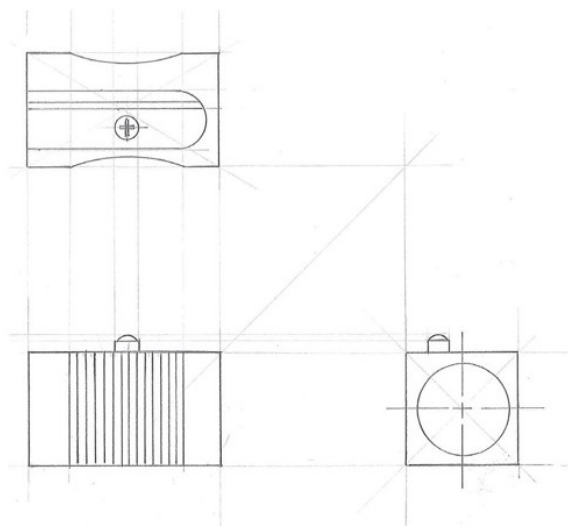

Orthogonal drawing is sometimes referred to as multiview drawing. A series of drawings – known as ‘views’ – are drawn to show every part of the object clearly. Orthogonal drawings are widely used by designers, engineers, builders, architects and manufacturers to specify the precise details of objects to be constructed or manufactured.

The application of orthogonal drawing is strictly regulated by a set of formal standards. These guidelines, published by Standards Australia, ensure that everyone interprets the drawing in the same way. VCAA’s *Technical Drawing Specifications* are designed to assist you in applying the appropriate standards.

Orthogonal drawings usually show the number of views needed to provide the maximum amount of information. The key is to ensure that there is enough visual information evident on the depicted views to avoid any confusion. Three views – the front, top and one of the sides – will usually provide enough

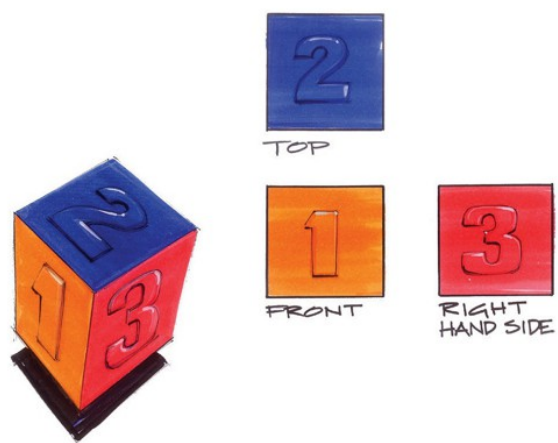

information for the drawing to be read clearly and understood. Of course, there may be times when more than three views are necessary.

**TIP: SEEING IN 2D**

The best way to visualise an orthogonal drawing is to imagine that the object is contained within a transparent box, and each part of the object can be seen on a different side of the box. This may help you to gauge how the object might look if the box is flattened out into a two-dimensional shape.



The placement or arrangement of views in an orthogonal drawing is extremely important. The common arrangement used in Australia is known as **third-angle projection**, which means that each view is positioned in the drawing so that it represents the side of the object in the view beside it. For example, the right-hand side view of the object is positioned on the right-hand side of the front view.

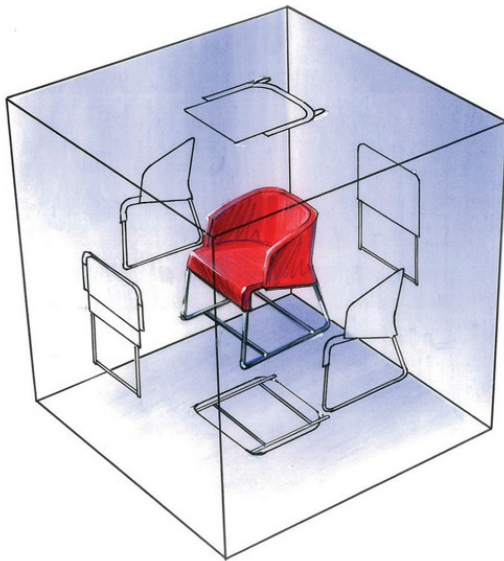

First-angle projection is used in some countries and represents objects quite differently. In a first-angle projection drawing, the right-hand side of an object would appear on the left-hand side of the front view. In the Visual Communication Design

course, third-angle projection is the preferred method of orthogonal representation, so never apply first-angle projection.

To indicate that third-angle projection has been used, a symbol appears on the drawing.

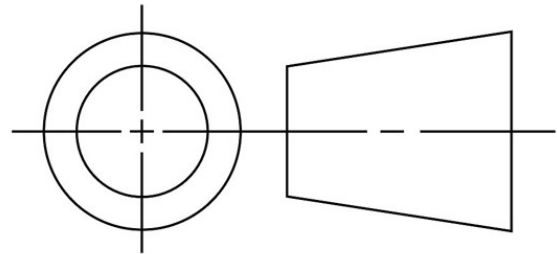

▲ The third-angle projection symbol. This should appear on all third-angle orthogonal drawings. Refer to the *VCAA Technical Drawing Specifications* for advised proportions when creating this symbol.

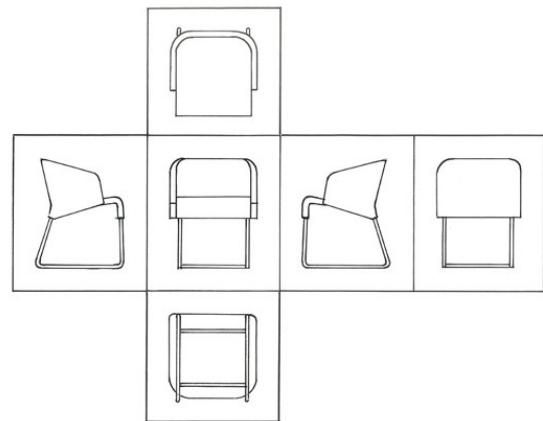

When drawing in third-angle projection:

- + all views should be aligned
- + the top view is always situated above the front view
- + the right-hand side view appears on the right-hand side of the front, and the left-hand side appears on the left of the front view
- + the VCAA drawing guidelines require you to appropriately label each view of an orthogonal drawing, for example FRONT VIEW, TOP VIEW, SIDE VIEW. Labels should be placed centrally under each view and written in upper-case type
- + the third-angle projection symbol must always be included on your drawing.

### TIP: FINDING THE FRONT VIEW



In many tasks, an arrow will indicate the front view of a three-dimensional object. This should be the view that shows the greatest amount of relevant detail about the length and height of the object. In an orthogonal drawing of a car, for example, the front view would show one side of the car, rather than the actual front of the car (with headlights, windscreen, etc.).

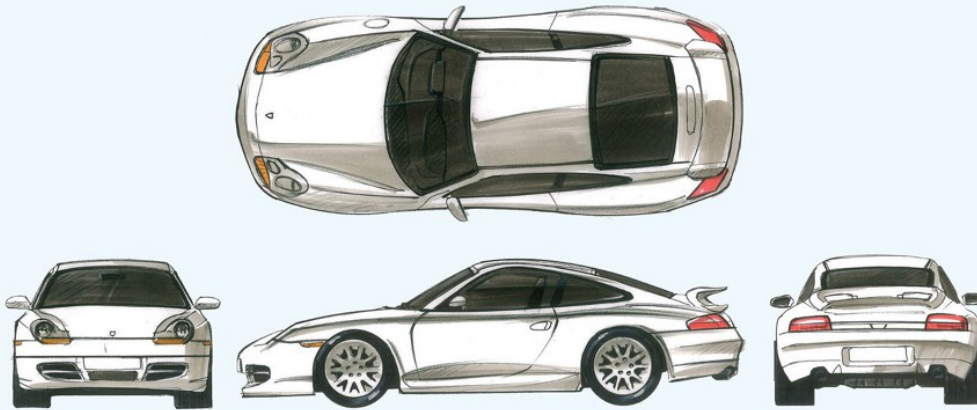

### A STEP-BY-STEP GUIDE TO ORTHOGONAL DRAWING



A simple method of constructing an orthogonal drawing of this three-dimensional form is outlined below. Remember to align your views correctly.

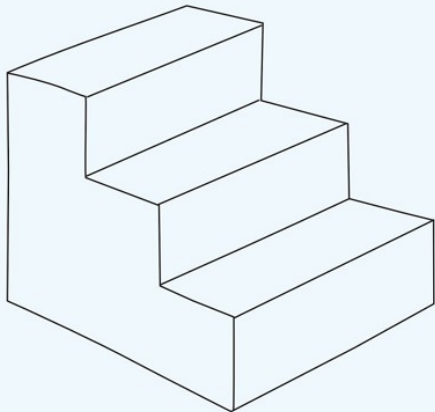

**Step 1:** Draw the FRONT view of the three-dimensional object.

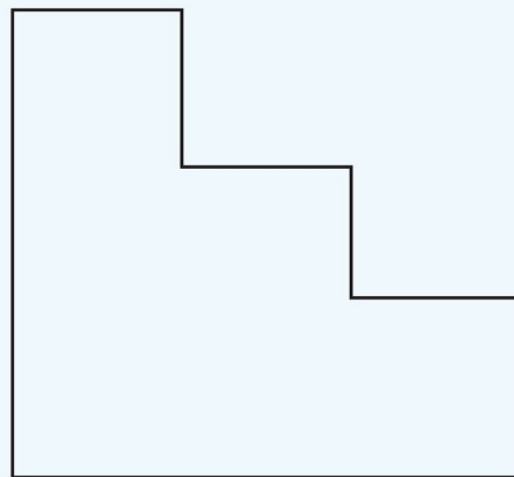

FRONT VIEW

**Step 2:** Draw light projection lines to project all relevant detail. The TOP view is drawn 40 mm above the FRONT view.

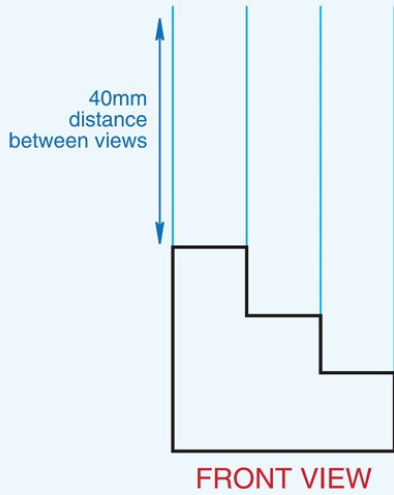

**Step 3:** Complete the TOP view using the projection lines as references.

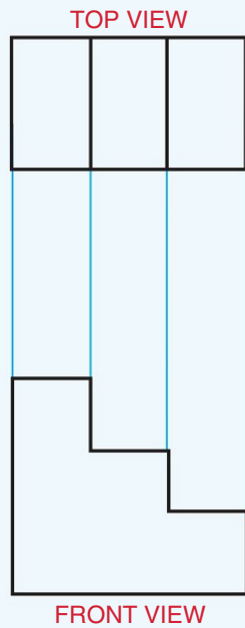

**Step 4:** Draw projection lines across from the FRONT view to form the SIDE view.

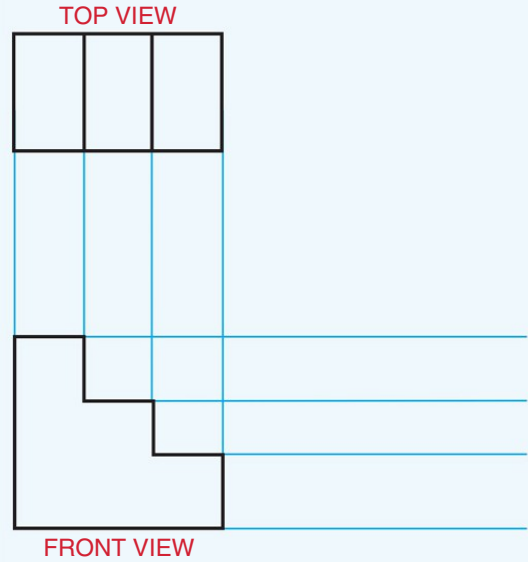

**Step 5:** Draw a 45° angle at the intersection of the last projection lines on the FRONT view.

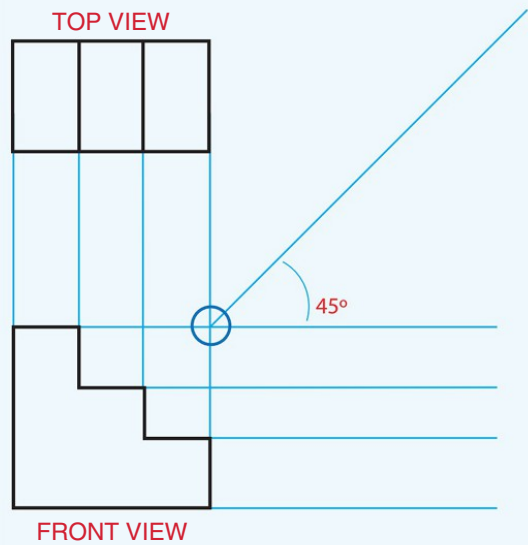

**Step 6:** Project lines across from the TOP view. Where they intersect with the 45° line, draw vertical lines down to form the SIDE view.

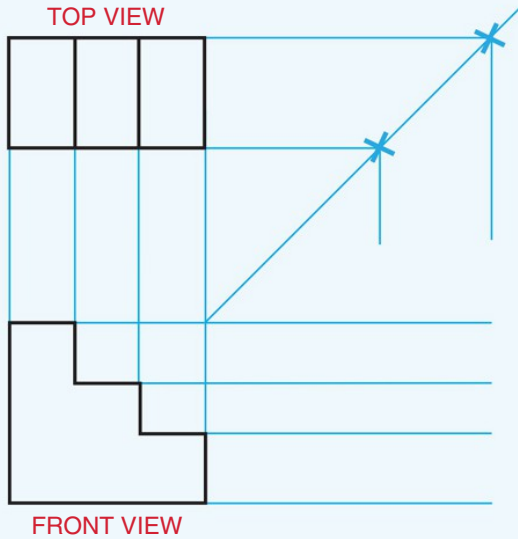

**Step 7:** The projection lines will make completing the SIDE view straightforward.

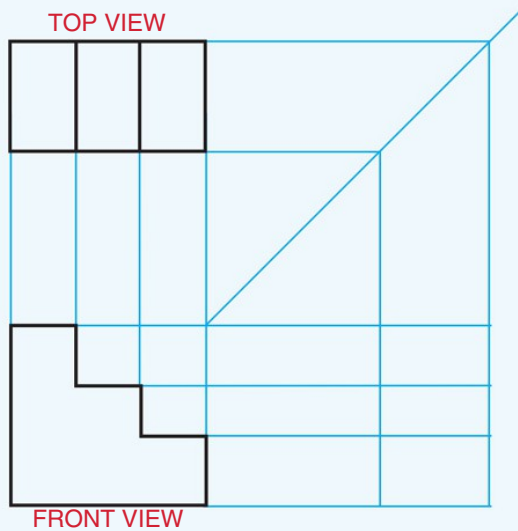

**Step 8:** Complete your drawing by outlining the SIDE view. Once your drawing is finished you can remove the projection lines or trace onto a clean sheet of paper for presentation.

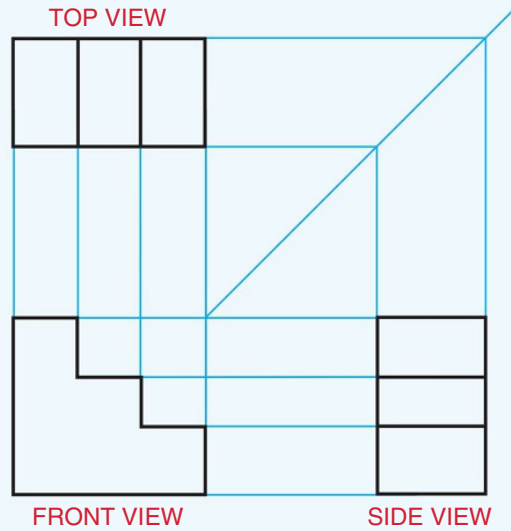

**TIP: USE A GRID**









Use grid paper for initial orthogonal drawings, as this can help you to align views correctly and keep your line work accurate. Once you have the drawing exactly right on the grid paper, you can trace your final drawing onto clean plain paper or scan it to use on the computer.

**Line conventions**

As in plan development drawing, the use of line in orthogonal drawing is significant. The width of lines indicates essential information, such as whether details are visible or hidden. Generally, only two line thicknesses – thick and thin – are used within one drawing. When providing extremely detailed information, architects and drafting professionals sometimes use medium lines as well.

▼ Line conventions and applications in orthogonal drawing

Industrial design	Line type	Application
	A thick continuous line	Used to show visible outlines
	A thin continuous line	Used to draw: + dimension lines + projection lines + hatching + short centre lines + general symbols + fictitious outlines.
	A thin broken line	Used to show hidden details
	A thin chain line	Used to show centre lines
	A thin broken line, thick at ends	Used to show a cutting plane
	A thin freehand continuous line	Used to show a break in a view, especially when drawing large objects

### Scale

Every orthogonal drawing must be drawn in proportion to the original three-dimensional object. The scale must be applied consistently throughout the drawing and indicated on the page.

Australian Standards provides recommended scale ratios for a consistent approach in two-dimensional drawing. The first numeral in the ratio indicates a measurement on the drawing, while the second numeral indicates the equivalent measurement on the actual object. For example, a scale of 1:5 indicates that one unit of measurement on the drawing represents 5 units on the actual object, so 1 mm on the drawing is equal to 5 mm on the object itself.

An orthogonal drawing that shows actual size must indicate a ratio of 1:1. Drawings that depict objects at smaller than actual size should be drawn using one of these scale ratios:

1:2	1:20	1:200	1:2000
1:5	1:50	1:500	1:5000
1:10	1:100	1:1000	1:10 000

For drawings that depict an enlargement of the original object, the following scales apply.

2:1 5:1 10:1 20:1 50:1

When creating an orthogonal drawing, you will need to establish which scale is most appropriate and enables you to depict the maximum amount of detail.

### Hidden detail

Sometimes an object features details that are internal and cannot be seen by viewing external surfaces. In these circumstances, orthogonal drawing is vital in depicting otherwise hidden details.

Hidden details are indicated by a thin broken line. It is essential that this line convention be followed so that the detail is clearly understood and not mistaken for an outline.

Hidden details might appear on any of the featured views.

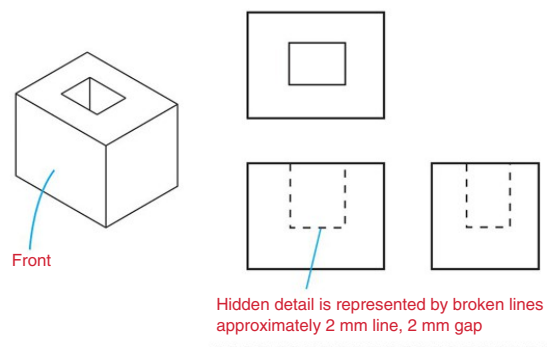

### Cross-sections

The cross-sectioning of an object allows for the internal details to be clearly shown. A cross-section is literally a 'cut-through' view of an object. An imaginary cut is made at an appropriate point to display the relevant information.

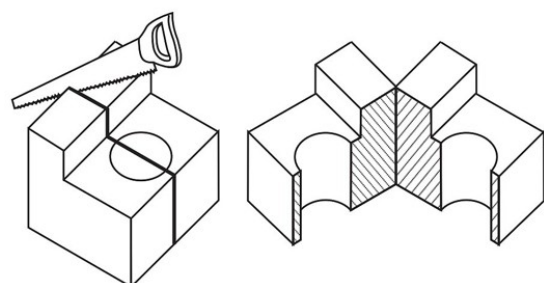

## The cutting plane

The path of the imaginary cut is indicated on the orthogonal drawing by a cutting plane. The cutting plane is shown as a broken line with thick lines at each end. Narrow arrowheads touch the end of the cutting plane, indicating the direction of the cut and the subsequent direction of view.

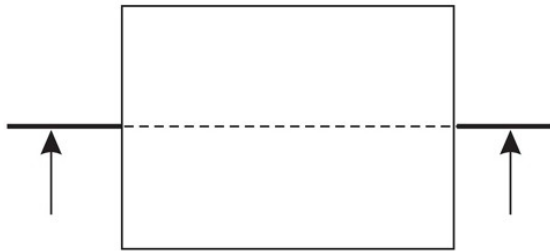

▲ A broken line indicates the cutting plane. The start and end of the cut are indicated by a short bold line.

The cutting plane is always labelled clearly. The first cross-section is labelled Section A-A, and subsequent sections are B-B, C-C and so on.

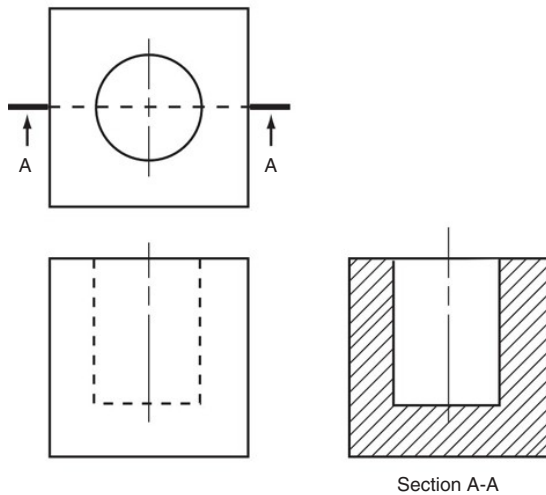

▲ The sections must be clearly labelled as Section A-A, Section B-B and so on, as required.

The section view is defined by the direction of the arrows on the cutting plane and appears on an orthogonal drawing, at the side of the regular views.

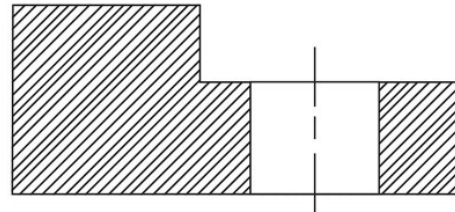
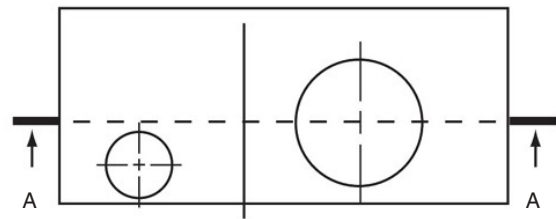

Section A-A

▲ Note that the direction of the arrows indicates the view that should be shown on the cross-section.

## Crosshatching

In order to show the solid areas of the object that have been 'cut', hatching is used. The hatching should be drawn at 45° and be suitably spaced relative to the area covered. It is recommended that wide spacing be used as long as the clarity of the technical information is not compromised. On smaller drawings, narrower spacing may be necessary. Hatching lines should be fine in order to distinguish the section from the outline.

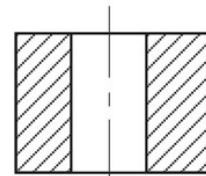

▲ The distance between hatching lines should be consistent and drawn at 45°.

## Crosshatching on adjacent solid planes

Where adjacent parts of an object meet, the direction of hatching should be reversed.

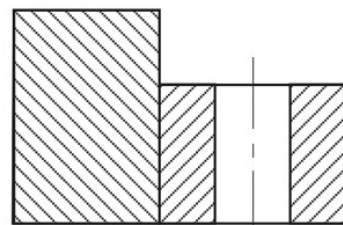



### Indicating large sections

Where very large sections are concerned, hatching can be limited to the areas around the outline to indicate a cut plane.

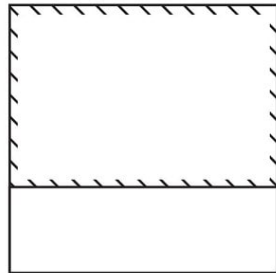

### Cylindrical objects

Cylindrical objects can show internal detail by using a half section rather than a full section.

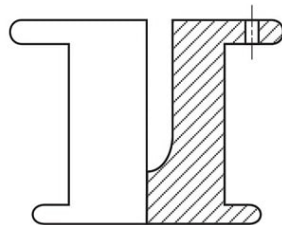

### Dimensioning orthogonal drawings

Dimensioning is the placement of measurements on an orthogonal drawing. Like other aspects of this drawing method, there are strict conventions to be followed when dimensioning.

The key to successful dimensioning is to make sure you include every relevant measurement that is crucial to the manufacture or construction of the object. However, it is equally important not to 'over-dimension', and each dimension should appear only once.

When you add dimensions to your drawing, make certain that you only use those dimensions necessary to clearly define the object.

Sometimes very complex objects are drawn in third-angle orthogonal drawing and it is important that the details of the drawing are very clear. Carefully plan your dimensioning so that the viewer can interpret the drawing quickly and without ambiguity.

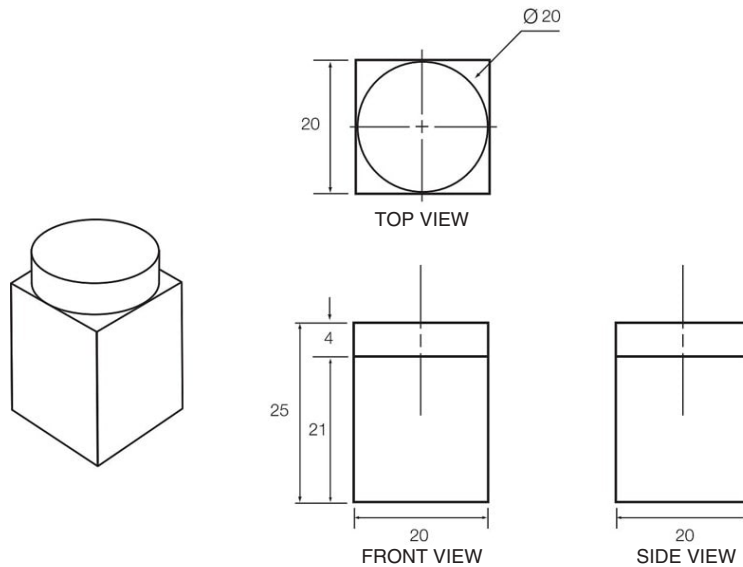

MEASUREMENTS IN MM  
SCALE 1:5

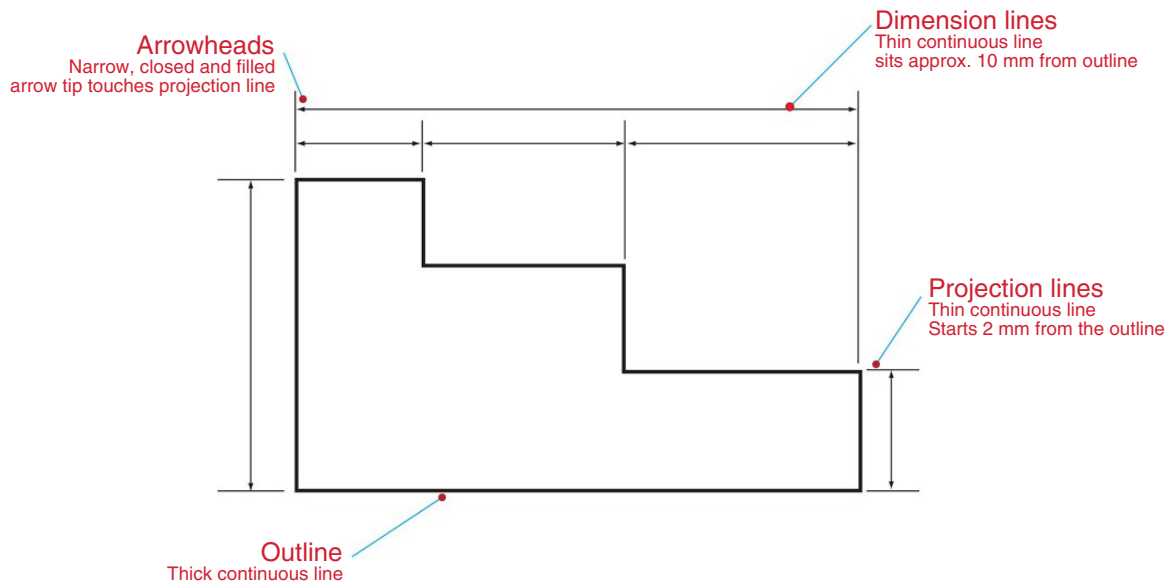

### The elements of dimensioning

**Projection lines:** These thin lines are placed outside the outline of the object and define the area being dimensioned. Projection lines do not touch the outline but sit approximately 2 mm from the outline edge.

**Dimension lines:** These are also thin lines and have thin, closed arrowheads at either end. The head of each arrow touches the projection line, defining the dimensioned area. Dimension lines are drawn 10 mm from the outline of the object.

Where there are multiple dimensions in the same area, dimension lines should remain 10 mm apart. The smaller dimensions are drawn closest to the outline.

The dimension of the object (not the drawing) is placed on or inside the dimension line. The dimension is never placed between the outline and the dimension line. The method you use when placing your dimensions is up to you (or your teacher) but clarity must be your priority. Preferred methods of representing dimensions are illustrated.

All measurements are in millimetres, and this should be indicated on your drawing by the words 'MEASUREMENTS IN MM' in UPPER-CASE letters. Don't add 'mm' to each dimension. Remember that the key is to keep the drawing as clear and uncluttered as possible.

#### ▼ Arrowheads

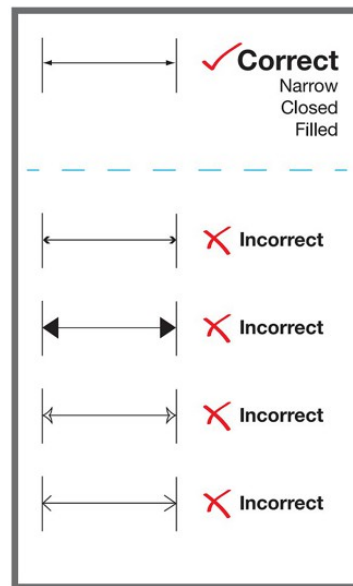

#### ▼ Dimensions

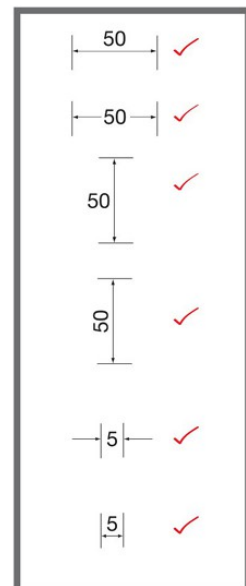

## Dimensioning circular details

### Centre line

A circular or other symmetrical feature on an object is indicated by the application of a centre line. The centre line is a thin chain line that is placed through the centre of the symmetrical feature.

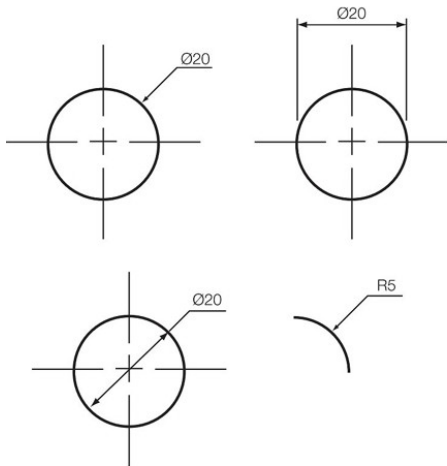

▲ Dimensioning circles.

When dimensioning a full circle, use the symbol  $\varnothing$  for **diameter**. When dimensioning part of a circle (an arc), use R for radius. The dimension lines with a single arrowhead used in the dimensioning of circular details are known as **leaders**.

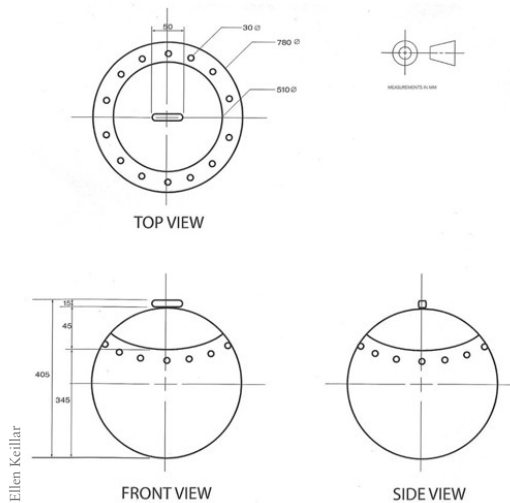

▲ Orthogonal drawing of a handbag design.

## Multiple dimensions

When you are working with complex objects, follow these guidelines.

- + The smallest dimensions are placed closest to the outline.
- + Larger dimensions sit at least 10 mm away from the smaller dimension.

At all times, remember to keep your orthogonal drawing as uncluttered and clear as possible.

## Dimensioning sections

Dimensions specific to the section can be shown on the section view but the standard rule for dimensioning applies: Don't over-dimension. Dimensions that appear on the three regular views do not need to be shown on the section view.

Leaders are used to indicate dimensions of any details that may otherwise be awkward to represent. Leaders are also used for notes within an orthogonal drawing.

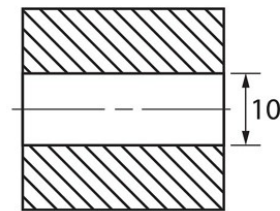

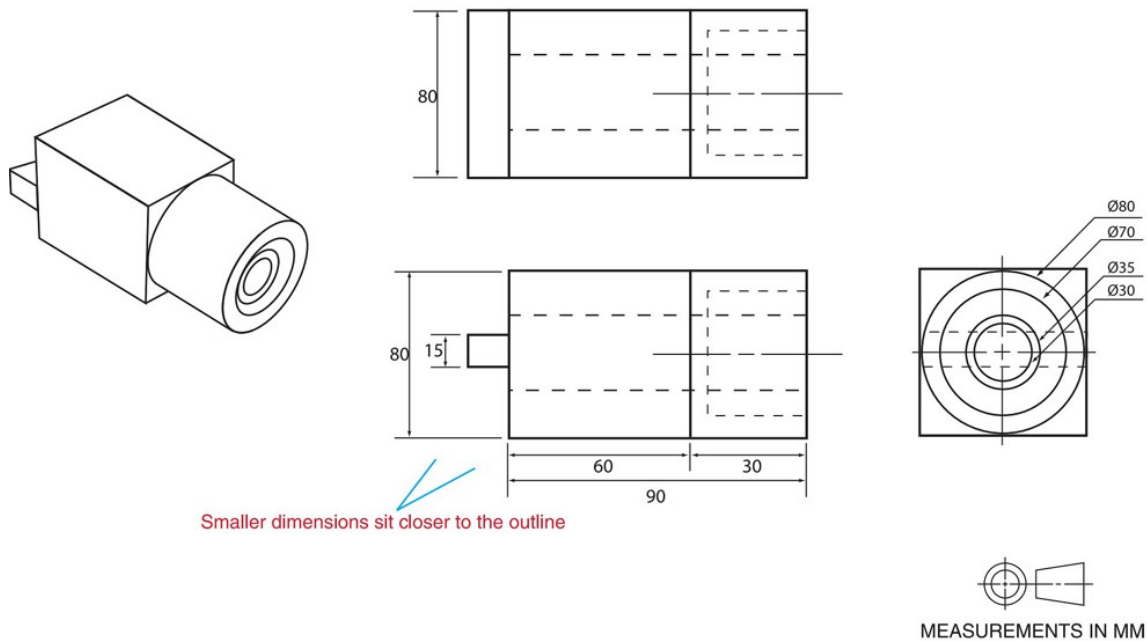

**TIP: WHEN USING LEADERS**

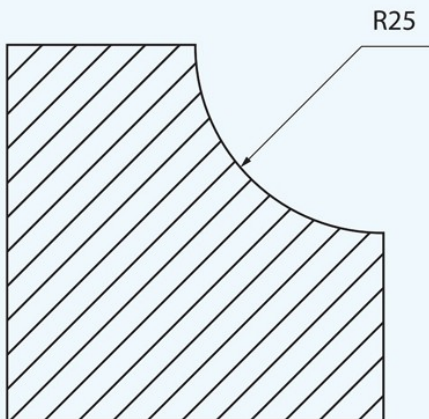

- A leader has a narrow arrowhead, similar to a dimension line.
- The tip of the arrowhead touches the outline.
- The leader is drawn at 45°.
- Leaders should be short and never overlap. (Dimensions may be repeated to avoid this.)

**Dimensioning details**

**Angular features**

When indicating the angle of a feature, dimensions should be expressed in degrees and decimal parts, such as 33° or 33.5°. If the angular measurement is less than one degree, include a zero before the decimal point, for example 0.3°.

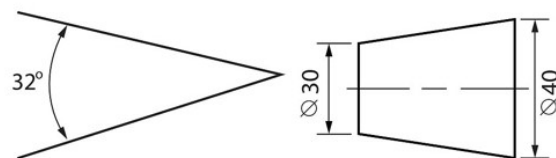

▲ Note that the dimensions are set vertically. This is often applied to save space on a drawing. Keep in mind that the placement of dimensions should be consistent across a drawing.

**Tapered features**

The following symbol indicates a tapered feature. The symbol indicates the direction of the taper and the ratio of taper to the diameter, and should be used whenever a tapered detail is shown in an orthogonal drawing.

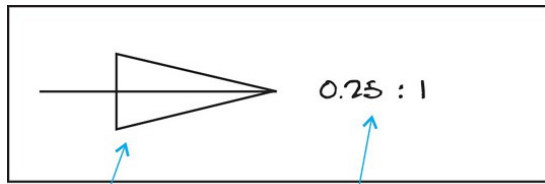

Symbol for tapered feature

Ratio of taper to diameter

▼ Dos and don'ts of dimensioning

Dos	Don'ts
Ensure that your projection lines and dimension lines are thinner than the outline.	Write 'mm' next to individual dimensions. Write the sentence 'MEASUREMENTS IN MM' elsewhere on your drawing.
Keep your line widths consistent.	Cross dimension lines or projection lines with other lines unless it is absolutely unavoidable.
Dimension on the view that shows a detail most clearly.	Use a centre line as a dimension line.

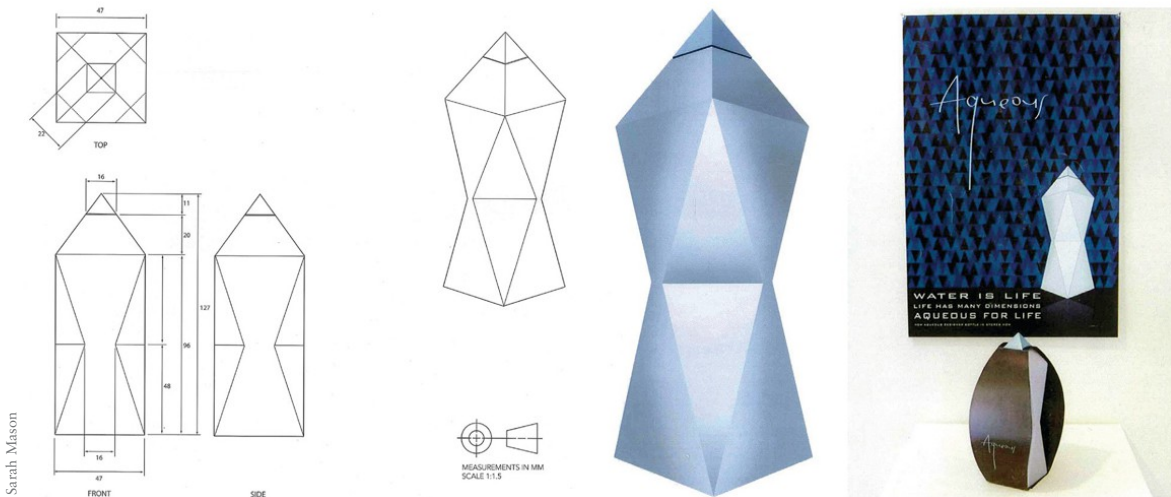

Sarah Mason

▲ In this student's design for a drink bottle, she created two-dimensional and three-dimensional representations and a 1:1 scale model with packaging.

## PACKAGING NETS

Packaging nets are a method of two-dimensional drawing used when an object is to be manufactured from a single piece of material. A packaging net drawing provides information about the form of an object to be created from material such as cardboard or sheet metal. Examples include cardboard boxes used for packaging and a point-of-sale display.

Within packaging nets, the representation of lines has great significance. Each line has a different

meaning and it is essential that the person viewing the drawing can understand the meaning of each line. Where to cut? Where to fold? What to discard and what to keep?

- + Broken lines indicate the folds of an object.
- + A solid line indicates the cutting edge.
- + If the object is to be glued, a row of black dots indicates the glue area.
- + Areas where adhesive is required, or where folded areas interlock to create the form of the object, are called tabs.

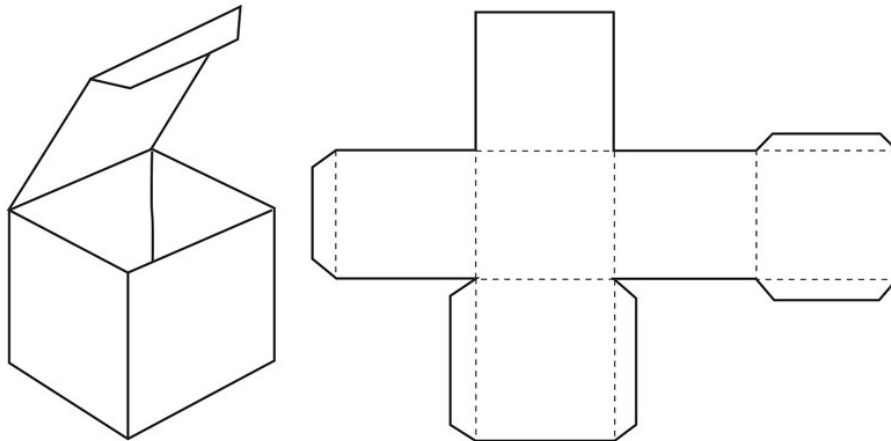

▲ Packaging net of a simple box

## TWO-DIMENSIONAL DRAWING IN ENVIRONMENTAL DESIGN



▲ Two-dimensional drawing of a floor plan

### Plans and elevations

In environmental design, plans and elevations are typically used to convey visual information about a three-dimensional design. Plans are the equivalent of the top view in orthogonal drawing, and elevations show the front and side views.

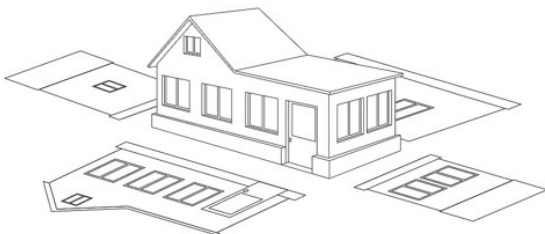

Plans and elevations designed for the purpose of construction are usually line drawings whereas plans and elevations designed for presentation can be much more detailed and may include colour, shadows, textures and backgrounds.

Plans are often used in real estate advertising to enable potential purchasers or tenants to see the floor plan of a property.

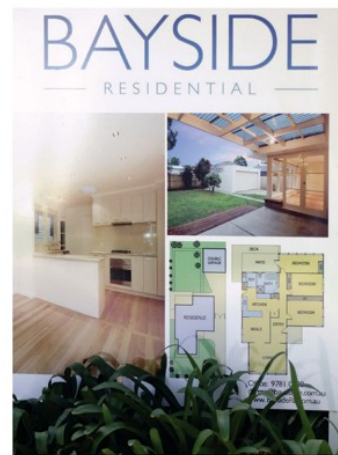

▲ Real estate advertising board showing floor plans

Reproduced with permission of Bayside Residential Real Estate

### Drawing the plan view

There are a number of conventions used in representing architectural details in two dimensions (refer to VCAA's *Technical Drawing for Students*). One of most common conventions is the use of symbols to describe features. Although their visual appearance may differ slightly if the drawing is completed by hand or via digital means, the meaning remains the same.

## Symbol conventions

Symbols should be drawn to the same scale as the plan and, where possible, be used without a text label or abbreviation. Many details of a plan, such as with domestic appliances (dishwasher, refrigerator, wall oven), are indicated by a rectangle with a diagonal line and may require an abbreviation for clarity.

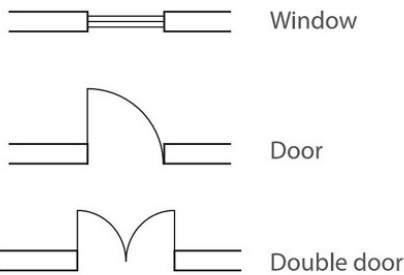

▲ Door and window symbols

CAD (computer-aided design) programs offer many examples of architectural symbols and these can assist in adding meaning and function to the drawing of a space. However enticing it may be to fill a plan view with details, always remember to err on the side of clarity.

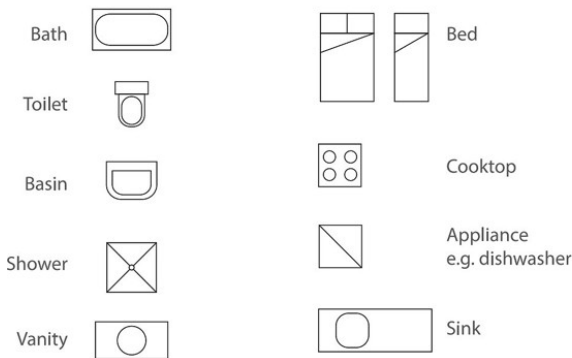

▲ General symbols. Note that the symbol used for general appliances such as dishwashers and fridges requires an abbreviation (see next table) to identify its purpose.

## Abbreviations

Abbreviations are used to label the features and fixtures used in a design.

▼ Examples of abbreviations used in plan and elevation drawing

Word	Abbreviation
Aluminium	AL
Bookcase	BC
Brick veneer	BV
Brickwork	BWK
Cement render	CR
Ceramic tile	CT
Clothes drier	CD
Washing machine (clothes washer)	CW
Cooker	C
Corrugated	CORR
Cupboard	CPD
Dishwasher	DW
Door	D
Down pipe	DP
Floor waste (bathroom/laundry)	FW
Heater	HTR
Hot water unit	HW
Linoleum	LINO
Open fireplace	OFP
Refrigerator	R
Roller shutter	RS
Shower	SHR
Stainless steel	SS
Terracotta	TC
Toilet	WC
Urinal	U
Vinyl	V
Wardrobe	WR
Weatherboard	WB
Window	W

Note that these abbreviations do not include all materials that are likely to be used in the construction of a dwelling. Details about fittings that do not affect the structure of a building such as floor coverings, wall coverings and interior decorations are usually listed on a separate document.

## Line conventions

Line conventions are important in environmental drawing. As in orthogonal drawing, the width of lines communicates different information. Although a combination of bold and fine lines are generally applied in plan and elevation drawings, medium lines are sometimes used where a detail needs to be differentiated.

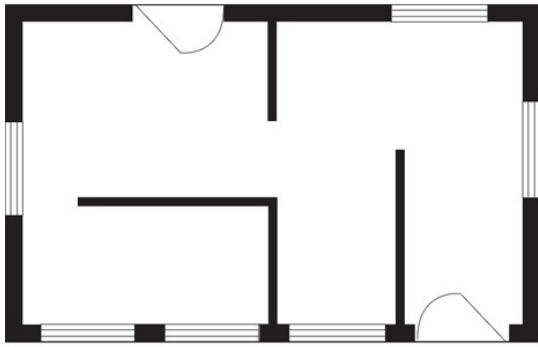

Bold lines (3 mm) indicate the outlines of structural walls and thin lines (1 mm) indicate interior walls, windows and doors. A black, filled shape, or thick outline, is used to identify wall thickness.

## Scale

The same scales that are used in industrial design are also applied to architectural drawing:

### ▼ Reduction scales

1:2	1:20	1:200	1:2000
1:5	1:50	1:500	1:5000
1:10	1:100	1:1000	1:10 000

### ▼ Enlargement scales

2:1	5:1	10:1	20:1	50:1
-----	-----	------	------	------

The most common scale applied in architectural drawing is 1:100.

## DRAWING ELEVATIONS

Unlike orthogonal drawings, which are labelled 'Front', 'Top' and 'Side' view, elevations are usually named for the direction they face, for example 'North', 'South', 'East', 'West'.

To create elevations, it is necessary to have a completed floor plan drawn to scale. The floor plan is used for the projection of lines to create the elevation views. The elevations are usually drawn to the same scale as the floor plan.

Additionally, you will need to establish the roof height of your structure prior to drawing the elevations.

### A STEP-BY-STEP GUIDE TO DRAWING ELEVATIONS



**Step 1:** Establish the ground level, window height, door height and roof height of your structure and indicate these with horizontal lines.



**Step 2:** Place your floor plan above the horizontal lines.

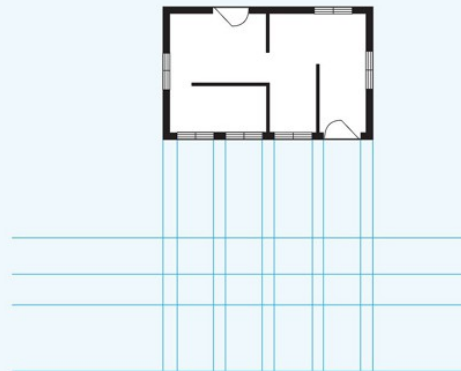



**Step 3:** Project vertical lines down from the plan view to indicate features such as doors, windows and external walls. Using the vertical and horizontal lines as a guide, add the details of the elevation view.

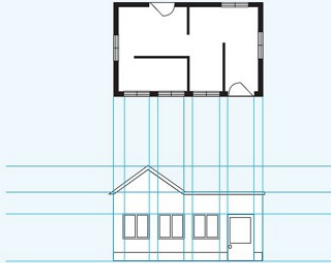

**Step 4:** Rotate the plan view and project lines to create the next elevation.

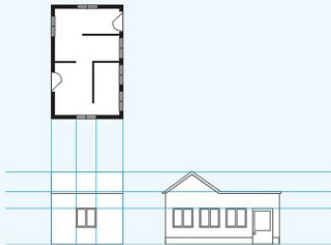

**Step 5:** Continue the process until all elevations are complete.

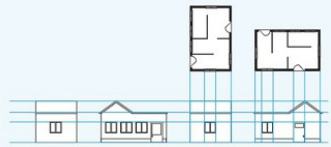

**Step 6:** Label each elevation in upper-case letters.

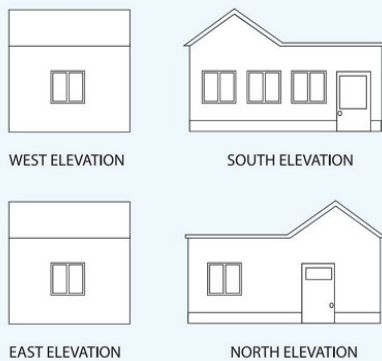

## A STEP-BY-STEP GUIDE TO DRAWING INTERIOR ELEVATIONS



Interior elevations can be constructed in a similar way to external elevations. The main difference is that the ceiling, rather than the roof, height needs to be indicated.

**Step 1:** Indicate (horizontal) height and ground lines then project (vertical) lines from the relevant section of the floor plan.

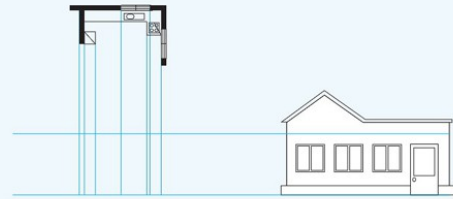

**Step 2:** Complete the interior elevation.

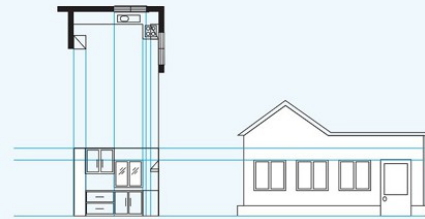

**Step 3:** Title the elevation in upper case. Usually the title explains the room purpose, for example, KITCHEN, LAUNDRY. When there are multiple elevations of the same room, the title may also indicate direction, for example, KITCHEN WEST ELEVATION.



## Dimensioning plans and elevations

There are usually many more dimensions on an architectural drawing than on an orthogonal drawing, so the method of dimensioning differs.

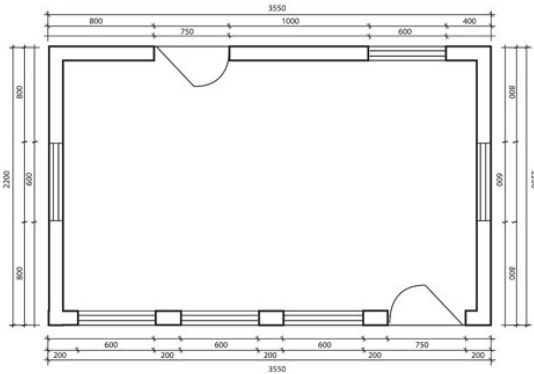

Projection lines extend from the outline by 2 mm. Dimension lines are required for all features of the structure. Smaller dimensions sit closest to the outline, for example, doors and window details.

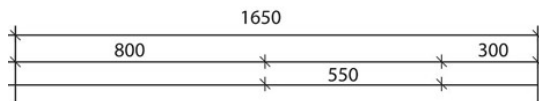

Instead of arrowheads, 45° strokes (2 mm long) are used to indicate the beginning and end of a dimensioned area.

## Section views

As in orthogonal drawing, section views are used to show details that cannot be seen on a regular

plan or elevation view. Section views can expose the structural features of a building and depict the internal configuration of spaces. Typically, section views use a thick outline to indicate the cut surfaces and progressively lighter line weights to show interior details.

## Rendering elevations

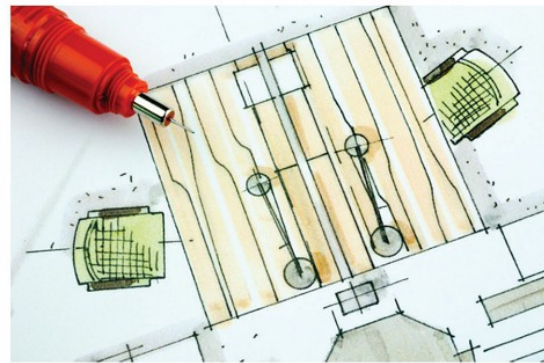

In environmental drawing, many exterior and interior elevations feature representations of materials. Architects and interior architects often render elevations to convey visual information about the materials and textures that will appear in the design.

CAD programs also offer rendering options and options for depicting textures such as wood, metal, stone, glass and fabric.

From simple dot and line rendering to depict textural detail to fully rendered representations of each material used, the use of rendering is often determined by the purpose of the final drawing.

For more information about rendering techniques, see Chapter 2.

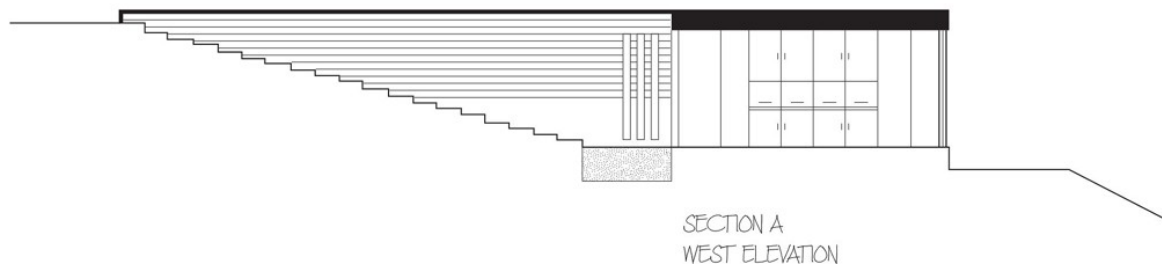

## LANDSCAPE DESIGN

In landscape design, plan views are an integral part of the design process. A landscape plan view provides an overview of a site and may indicate areas for landscaping, construction and planting. It may be a line drawing or fully rendered presentation.

A landscape plan often includes annotations that indicate the nature of a planting scheme or the specifics of the materials to be used in the construction of a feature. Elevations are also used to illustrate the appearance of views within the landscape design. Like architectural drawings, landscape designs are drawn to scale.



Shutterstock.com/Scott E. Feuer



# OBSERVATIONAL DRAWING AND RENDERING

CHAPTER

2

---

## In this chapter:

+ Observational drawing .....	44
» Media .....	44
» Scale, proportion and context in observational drawing .....	45
» Establishing hierarchy .....	47
» Multiple views .....	48
+ Rendering .....	48
» Rendering techniques .....	48
» Rendering to represent form .....	51
» Representing textures and materials .....	53

## Learn the language

form	light source	shadows	texture
highlight	proportion	sketching	tone

You will find helpful tasks related to drawing and rendering in Part B and throughout *Nelson Visual Communication Design VCE Units 1–4 Workbook, Edition Three*.

---

# OBSERVATIONAL DRAWING

Observing objects within an environment assists in recognising and representing **form**, relationships, scale and **proportion**.

Many great designers have the ability to represent what they see through drawing. Drawing objects and products that already exist can help to inspire and inform a new design. The design of a new toaster, for example, may see a designer **sketching** the form of an existing toaster to help in understanding the general proportions, shapes and function of the product.

The practice of drawing from the direct observation of products, constructions, spaces, buildings and environments can help to build your drawing and illustration confidence. When you observe an object from direct physical proximity to the object, the ability to reproduce what you see is a vital skill to develop.

## MEDIA

Observational drawings can be produced in any **media** either in colour or black and white.



Tom Grech

▲ Observational drawing using marker and aquarelle (watercolour) pencil

The choice of media often comes down to personal preference for the medium you feel best displays the qualities of the drawing. Observational drawings

may be primarily linear or fully rendered with representations of tonal variations, light and shadow, as well as surface **textures**.



Sophie Coleman

▲ Observational drawing using greylead pencil on watercolour paper

**Tone** and the representation of light and **shadows** are very important in observational drawing. On any subject matter there will be differing amounts of absorbed and reflected light that combine to suggest the form and textures of the image. Within a black leather chair, for example, there will be varying amounts of light changes that require changes in tone. A shiny leather surface can reflect so much light that some areas of the image are left white, yet a black chair with a matte texture is more likely to reflect mid-grey tones, which are more subtle.

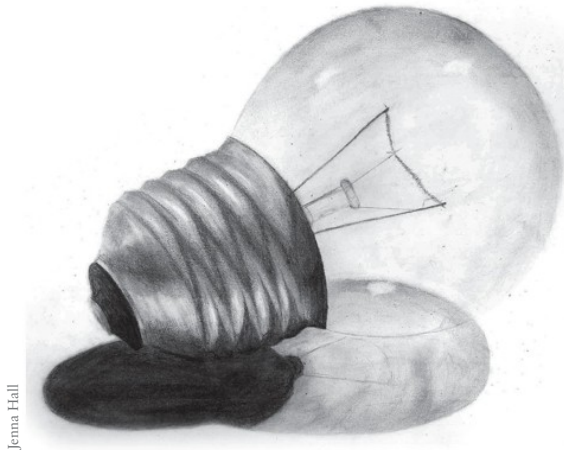

Jenna Hall



Kelly Berger

- ▲ These two observational pencil drawings of light bulbs are executed very differently. Both make excellent use of tone to create the illusion of transparent glass and metal. Note the different uses of negative and positive space and the angle of view on each drawing that create striking images of an otherwise mundane object.

It is essential to recognise that the variations of tone are what define the forms and textures in an image.

## SCALE, PROPORTION AND CONTEXT IN OBSERVATIONAL DRAWING

Some of the most valuable skills acquired in observational drawing are the ability to represent correct scale and proportion. Often when observing an object in its natural environment, you automatically refer to the objects around it and develop a concept of scale. When representing objects with a degree of realism, it is important to use correct proportions. Directly observing an object enables you to view relationships between parts of the object and to compare them with surrounding features. An observational drawing of a mobile device, for instance, may become more effective by including a human hand in the drawing. Establishing a relationship between the hand and the form of the device allows you to communicate the proportions of each element clearly.

### Scale and proportion

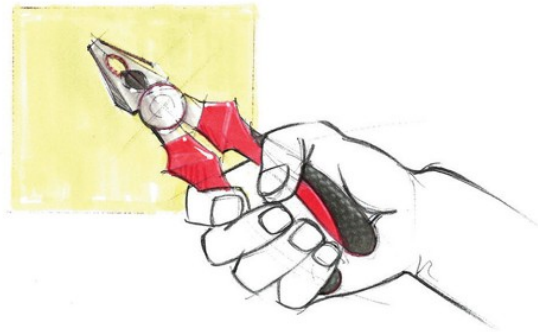

Mark Wiken, Studio Workshops

In perspective drawing, the relative proportions of objects change according to the principles of the perspective method being used. The viewing position will also have an impact on the placement of perspective images in the foreground, midground and background. The visual relationships between aspects of a drawing will affect the realism of the representation.

How do we recognise the scale of objects in three-dimensional drawing? We know that the size of the house in this illustration is obviously not the actual size of a real house, because it fits within the A4 pages of this book.



When we view an image of an object, we are provided with clues that help us to understand the relative proportions. Clues such as trees, cars and people are used in drawing to establish scale.

We are familiar with the proportions of the human body; therefore, recognising the proportions of an object in relation to a person is easy.

Keep in mind that the depiction of adults and children needs to be clearly defined through the application of details such as clothing or facial features. Otherwise, a short figure next to a much taller figure will distort the scale of the illustration.

To draw human figures in perspective, establish the placement of the first figure. Ensure that you are very clear about the eye level of the drawing – floating people simply don't look realistic!

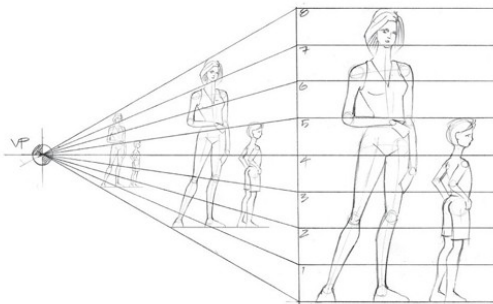

To effectively manage proportions in perspective drawing, pencil in the figure and then project lines to the vanishing point. These projection lines form guidelines for more figures.

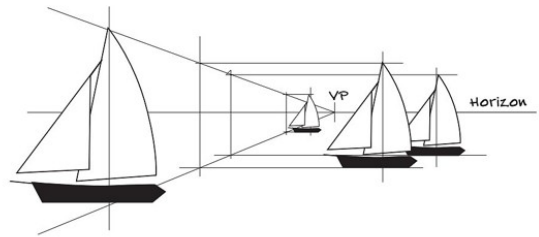

The same principles apply when drawing trees, shrubs, cars, boats or any other object used to establish scale.

### TIP: HUMAN PROPORTION: HEADS OR TAILS?

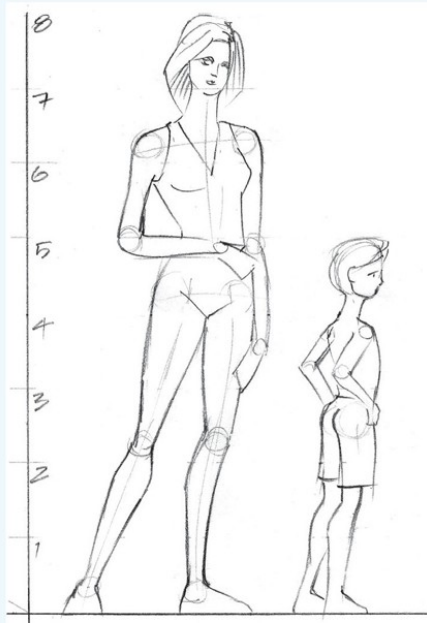

The height of an adult human figure is approximately equal to 7.5 to 8 heads. When drawing an adult figure, use 8 heads as a guide to gaining the correct body proportions. When drawing children, use 4 to 5 heads as a guide.

### Foreshortening

Foreshortening is a term used to describe objects that appear shorter than they actually are in order to emphasise the illusion of depth.

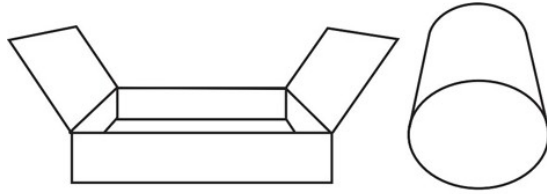

As with crating, foreshortening on complex objects is easily depicted by drawing a perspective box and freehand sketching the object within the box.

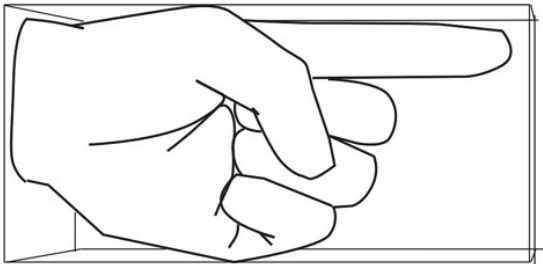
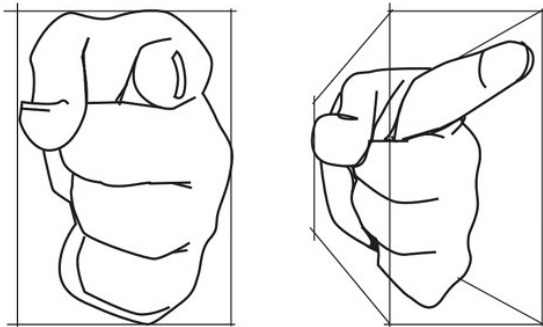

## Context

The effectiveness of an observational drawing can be amplified when depicted in a clearly recognisable context. The context can indicate the function or use of the design product and can also assist in emphasising scale and proportion. Give consideration to whether a drawing needs to be placed within an environment or used beside another object or objects to establish how it is used.



- ▲ The figure provides a clear context for the function of the handbag as well as providing a visual reference for the proportion of the bag to a human figure.

## ESTABLISHING HIERARCHY

One method of establishing hierarchy in perspective drawings is to overlap objects. Dominant objects appear in the foreground, partly obscuring or cropping less dominant objects. The key to overlapping objects in perspective is to treat objects as though they are made of a transparent material.

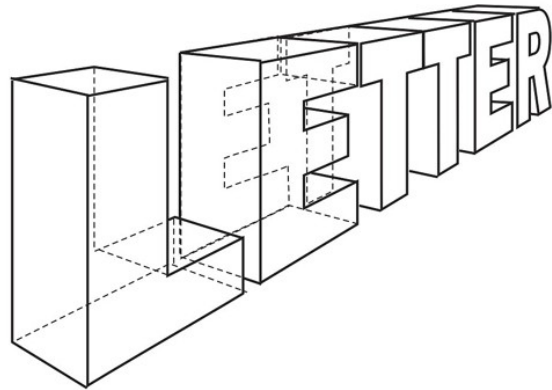

To create the correct proportions of objects that overlap other objects, draw them as though they are made of glass. This enables you to construct the correct perspective proportions of objects behind the dominant feature. This method is particularly useful



when objects have see-through features such as glass walls and cutaway areas. Of course, design elements such as colour and tone can be added, and design principles such as contrast and cropping applied, to create a hierarchy in a three-dimensional drawing.

## MULTIPLE VIEWS

A helpful application of observational drawing is to represent multiple views of a single object. This is especially important when dealing with three-dimensional objects. Freehand sketches can assist in communicating the range of details in an object. This means that key information about the surface, appearance and any textural details can be seen from varied viewpoints. During the design process, drawing from different viewpoints can enable a designer to judge proportion and evaluate the aesthetic success of a three-dimensional design.

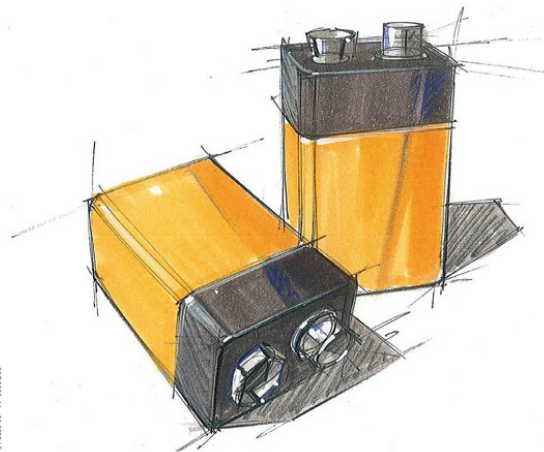

Mark Wilken

▲ Multiview sketch of a 9-volt battery

## RENDERING

Rendering is the application of tone and texture to create a three-dimensional appearance and/or to depict the surface details of an object.

Rendering is important when the form of an object needs to be communicated. If a furniture designer, for instance, needed to illustrate a new line of chairs, it would be important to depict the characteristics of the fabrics and materials used in their production. The rendering of materials, using a range of media, can

communicate a great deal of visual information about products and objects.

You may have seen illustrations of proposed designs labelled as an 'artist's impression'. Architects and interior designers often use these 'impressions' to help clients visualise what may otherwise seem to be a complex plan. The use of colour, line and tone – to demonstrate surfaces, texture and detail – help to communicate ideas that might otherwise exist solely as instrumental drawings.

## RENDERING TECHNIQUES

Effective rendering can be achieved through the application of an almost limitless range of media. Markers, ink pens, computer rendering, gouache and pencil are probably the most popular methods, with computer-generated images becoming increasingly common. It is also possible to achieve striking results with combinations of media, as well as pastel, collage, watercolour, cut paper and airbrush.

When rendering images, establish the purpose of your image before you begin, as this will determine the most suitable medium. What is the purpose of the drawing?

- + Is it to express the realistic form of an object?
- + Is it to emphasise a feature or detail?
- + Is it to create visual interest?
- + Is it a combination of the above?

Test different options before selecting your medium, so that you can be certain that your choice is appropriate to the purpose.

### Pencil rendering

Pencils generally consist of a graphite core within a wooden casing. It is also possible to use graphite sticks, which are often thicker and are encased in paper or plastic.

Pencils are available in a variety of grades that affect their rendering qualities. Pencils in B grades are softer and offer a smoother application over larger areas. H grades are hard and are more useful in line work and drafting.

Soft pencils enable you to render a surface with a range of tones by layering applications of tone. When using soft coloured pencils, it is possible to layer similar hues of one colour to generate an intense area of solid colour that can add visual interest. When working with pencils, applying colour thickly may damage the paper surface. Layering is more effective and allows for flexibility.

Water-soluble pencils are very soft and can be blended easily. They offer the potential for striking rendering effects and can be used alone or with markers to create effective imagery.

Paper stumps, which look similar to pencils but are made from compressed paper, can be used to blend soft pencils. Use with care, however, as they can flatten tones if used too liberally.

In pencil rendering, working with the surface colour of the paper will provide **highlight** tones. When working on a white paper, keep the surface clean and clear of any tone to create effective and bright white highlights.

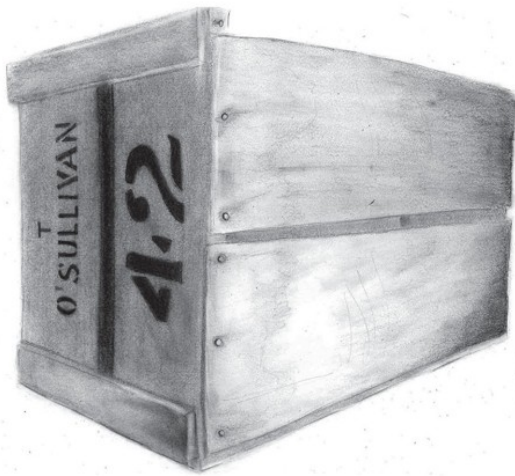

Jenna Hall

- ▲ This student used a combination of soft greylead pencils and paper stumps to apply an even tonal change and create a smooth transition between highlights, midtones and darker tones.

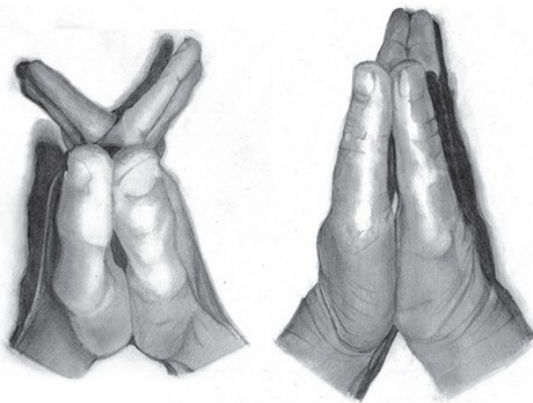

Grace Ashworth

- ▲ Note how this student has used the white paper. The white areas create strong highlights and give a greater level of realism to the representation of form. The use of white paper provides a much broader tonal range in a drawing.

ISBN 9780170401784

## Rendering with ink or pen

Rendering with ink or a pen such as a fineliner or a technical pen requires quite a different approach to working with pencil. Variations in line quality – rather than layers of tone or varying pressure – make the difference in ink-based renderings. You can use fineliners, ink and nibs, or technical pens to create detailed renderings or quick sketches. A range of techniques can be used with permanent media such as ink.

## Dot rendering



Izzie Klingels

**Dot rendering** can be used as an effective method of conveying tonal variation. Dots of a consistent size, but varying in their proximity to one another, create a range of tones that can communicate shadow and highlight areas. The key is to ensure that you don't get sloppy with your application of dots. Consistency, though time-consuming, leads to the best results with this technique. Note that you do not have to fill an entire space to suggest texture and form.

Nelson Visual Communication Design VCE Units 1–4

## Crosshatching or line rendering

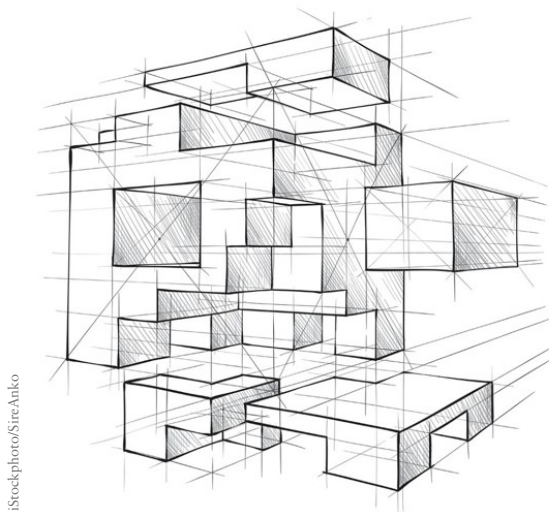

istockphoto/SireAnko

**Crosshatching** is a rapid method of applying tone that can be very helpful in idea development and in communicating tonal information quickly. Vertical, horizontal and diagonal lines vary in proximity to one another, creating tonal and textural variations. This technique is often used to suggest textures such as fabric, wicker and natural fibrous materials as well as enhancing tone on freehand sketches. To ensure the success of this technique, try to keep your line widths consistent.

## Marker rendering

Popular due to its rapid application, marker rendering is commonly used by industrial and product designers to present concepts. Markers contain intense pigments in an alcohol base, which provide quick-drying colour. They are best used on a smooth, non-absorbent or non-bleeding surface such as bleedproof paper. Markers often have two tips – a broad tip and a fine tip at opposite ends of the pen – allowing for both fine work and the application of larger areas of colour and tone.

Available in a range of colours, markers are also sold in sets of greys – warm, cool and neutral – which provide scope for rendering products in tonal detail. Marker refill ink can be used with the cotton pads of a multilith printer to create broad strokes of colour, useful in background effects.



▲ Markers are applied smoothly in product rendering to create textures. Overlap marker strokes by two-thirds to avoid a striped effect. Build up tones by working with lighter hues first.

Applying markers takes practice and it is advisable to test on rough drafts before applying to a finished pencil or pen drawing.

To create block areas of colour, overlap consistent marker strokes; this will help to disguise streakiness and provide even tone. If using different markers to build tone, use the lightest marker first and build up colour with darker hues as required.



▲ Markers can be applied in a sketching motion to create a freehand effect.

## Computer rendering

Increasingly often, software programs are used as universal drawing and rendering tools. Methods of rendering vary between bitmap and vector-based programs (see Chapter 7) but both types allow for the effective representation of tone and texture. It is possible to scan artwork and trace it in either a vector-based program such as Adobe Illustrator or a bitmap

program such as Adobe Photoshop. With a bitmap or raster program, tools and filters can be used to render the drawing, and textures and patterns can be applied. Vector-based programs enable rendering using gradient, pattern and solid fills.

Computer-generated techniques offer fast, high-quality methods of applying rendered surface details through the application of filters and special effects. Just keep in mind that everyone else has access to those filters and effects too – so use them creatively!

The best approach to drawing with computers is always to begin with a hand-drawn sketch. Whether you render it or use it as a guide, an initial sketch will invariably lead to better results on the computer. Most top digital illustrators begin their work with a traditionally executed drawing.



Tom Grech

▲ The use of brush tools, layers and gradients in raster or bitmap programs such as Adobe Photoshop can, with practice, create photo-realistic imagery. Note that in this example it is possible to see the original drawing lines.

## Airbrush rendering



Mark Wilken

▲ An airbrush.

ISBN 9780170401784

Airbrushing is used in many areas of design, although its use has been somewhat reduced by the growth of computer rendering. Airbrushing, like marker rendering, can provide fine work or broad areas of colour. Looking like a slightly bulky pen, the airbrush draws ink from a small reservoir and propels it into the air in a fine mist using air pressure from an attached compressor.

Used in conjunction with removable masking film, masking fluid or templates, the airbrush can be used for detailed drawings of almost any scale. A combination of varying the airbrush pressure and distance from the work controls the spread and intensity of ink coverage, which in turn controls the tonal qualities of the drawing. Traditionally used in street art, the use of aerosol paint with a range of different nozzle varieties is used increasingly by illustrators. Often used in conjunction with stencils and masks, the effect is very similar to airbrushing work.

## RENDERING TO REPRESENT FORM

In depicting the characteristics of form, the principles remain the same no matter which media you choose to work with.

### Light source

Natural or artificial light influences the appearance of objects, creating highlights and shadow areas. When light from the source hits an object it will often create a highlight, midtones and dark tones, and cast shadows.



Nelson Visual Communication Design VCE Units 1–4

Depending on the surface texture of the object, it may also reflect light.

It is through the representation of light and dark areas that a three-dimensional form can be depicted. It is, therefore, important to identify the **light source** as the first step. In daylight, it is sometimes difficult to ascertain the primary source of light but invariably it will be a window or, if outside, the sun. In a dark space, a light globe or lamp will create a light source that will appear more clearly defined than the more diffused light of day, and will create sharp contrasts.

In rendering the form of objects, you may need to make an arbitrary decision about the primary light source, taking into account reflected light from other surfaces or secondary sources of light.

In the past, formal training in illustration involved learning 'rules' about light and shadow. In fact, in many classical paintings you can see how strictly these rules were followed, with very specific applications of light and cast shadow areas.

Although it is still very important to understand the effect that light has on an object, the application of tone is much more intuitive today, relying heavily on your observational skills and sensitivity to the subject matter.

Freehand shadows can also be an effective means of 'grounding' an image and placing it within a given context. This, like the more formal construction of shadows, provides a sense of realism and three-dimensional form.

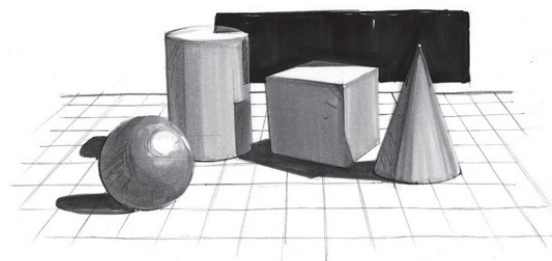

- ▲ This image used both shadow and a hand-drawn grid to 'anchor' the images. This provides a believable context for the forms by 'grounding' them upon a surface.

### TIP: THE POINT

When rendering, keep your pencils sharp but don't press into the paper as this will show through as an indentation on the page when you draw over the area again.



## Tonal scale

A good method to use when rendering, regardless of the medium or rendering method, is to first create a **tonal scale**. A scale becomes a good reference point when rendering, as you can select the tone that best suits your drawing task and chosen medium.

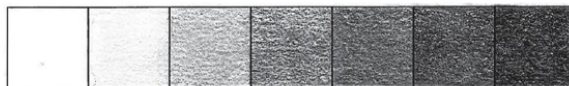

### TIP: DON'T BE AFRAID OF THE DARK!



When applying tone, use the full tonal scale and don't be afraid of using truly dark tones.

When drawing from observation, it can be tempting to stick to the midtones that will produce a mediocre grey image. For effective results, resist the midtone temptation. Use a 6B pencil to generate areas of shadow. Use the contrast between highlights and dark shadows to emphasise the form of an object.



Mikaela Revell

When the darkest tone is placed next to the lightest tone, for example, the differences between the two are intensified, creating a distinctive and sometimes dramatic lighting effect.

## REPRESENTING TEXTURES AND MATERIALS

Applying materials to objects helps a designer create a sense of realism and enables the viewer to recognise the characteristics of a design. The inclusion of textural details, tone, colour and pattern helps to define the features and forms of objects and spaces. Designers in all design areas apply the rendering of materials to some aspects of their work. Whether executed by hand using sketches or refined in CADD software, the application of materials is key to communicating the specific qualities of a design.

### VIDEO DEMO: RENDERING

Learn how to render objects to represent different textures and materials. Go to <http://nelsonnet.com.au> and use the code at the back of your book to log in. Click on 'Resources', then go to Chapter 2, page 29 video.

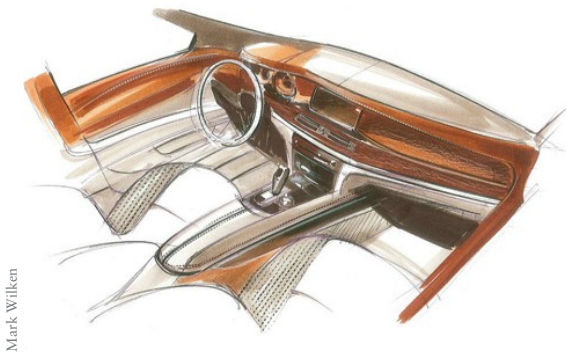

Mark Wilken

Observe and familiarise yourself with the textures around you. Your clothing, the table, the carpet and flooring all reveal different textural qualities. Once you begin to observe and practise drawing the textures around you, you will see how it becomes easier to create the appearance of materials.

## Natural textures

Textures that occur in nature are rarely uniform and have characteristics that are not found in human-made materials. Natural textures such as wood include the grain of the timber, knots and other imperfections due to age, damage and weather.



Mark Wilken



Mark Wilken

When drawing natural textures it is important to include details that give an authentic appearance. However, as important as it is to incorporate texture realistically, you should judge just how much detail is required. Too much detail can detract from the purpose of the drawing.



▲ Irregular lines can create the unique character of wood grain. Avoid being too uniform in your representation.



Mark Wilken

It is not always necessary to fill an area with textural detail, as a section of texture can often convey enough information. Stone, grass and foliage are commonly depicted in illustrations, and small sections of texture can communicate the characteristics of a given area rather than filling space with detail. When drawing trees avoid representing every leaf and branch as this can cause the image to appear contrived.

## Fabric and textiles

The diversity of available fabrics makes for equally diverse methods of illustration. In the fashion and furniture design areas, the representation of fabric texture becomes very important. In the initial stages of a design process, fashion designers might use style sketches to identify the basic form of a garment and use rendering techniques such as crosshatching to identify the texture. More detailed drawings would then follow, showing the selected fabrics in greater detail, with annotations.



Grace Ashworth

When representing fabrics such as woven cloth, you should observe the direction of the threads. Woven fabrics – whether created by hand or by a machine – have threads that travel in two different directions.



Ellen Keillar

Called the weave and the weft, these threads will reflect light differently. It is rarely necessary (or advisable) to show every thread but it is important to appreciate that fabric is not flat and mono-directional, and to convey this in the rendering.



- ▲ The textural details of these fashion designs are indicated through marker and pencil rendering techniques. The use of a texture board and the inclusion of tone help to illustrate the characteristics of the fabrics.



- ▲ Leather handbag. Note the inclusion of some grain and a form that suggests stiffness.

Fashion illustrations convey the qualities of fabric through freehand drawing and rendering. Fashion designers use drawings to show not only the form of a garment but also the characteristics of its fabrics.

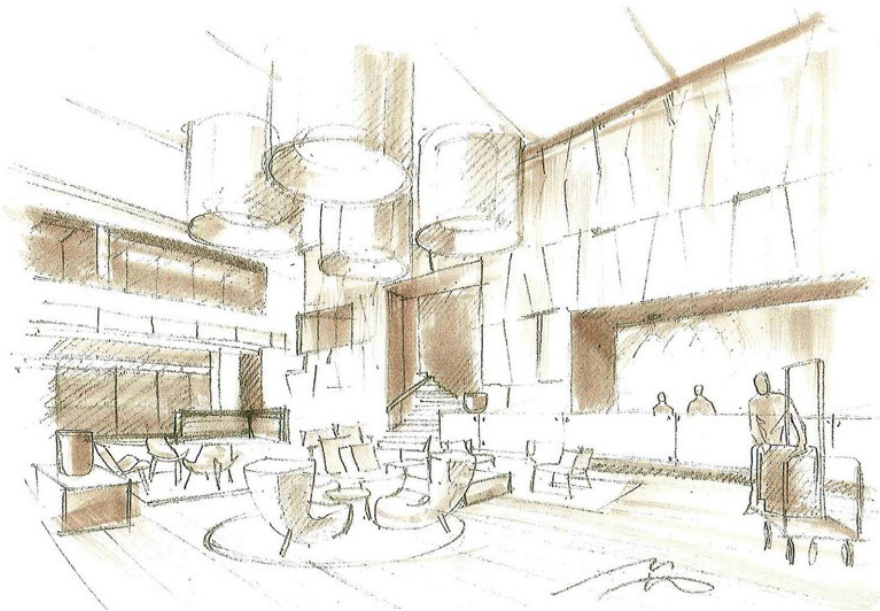

- ▲ Interior designers often need to represent multiple materials in a single interior. Application of tone and the use of crosshatching can indicate where textures exist in an environment.



Rendering in fashion drawings shows not only the appearance of the fabric but also its physical characteristics such as reflective or transparent qualities, the richness or texture of the material, or the layering of separate fabrics in one garment. Fashion drawings, by their nature, tend to be loose and may use a range of methods such as marker, pencil, watercolour, collage and mixed media.

## Metallic and reflective surfaces

Materials that reflect light – such as glass and metal – can be challenging to draw. The textural characteristics of reflective surfaces are often smooth or slick.

**Metallic surfaces** such as chrome have no colour of their own and only reflect the surrounding colours. To capture the appearance of metallic objects, colours should be crisp, intense and bright. The application of colour often depends on the shape of the object to be drawn.



- ▲ When drawing high-shine or reflective surfaces, be sure to leave some areas white to emphasize their reflective qualities.

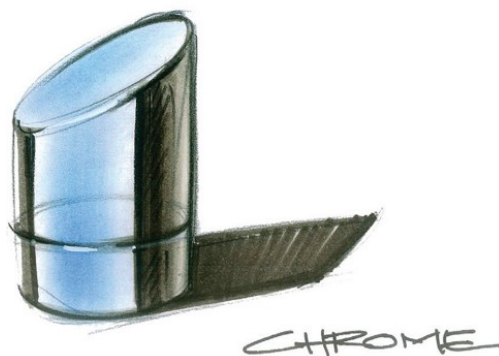

A metal cylinder, for instance, may use a series of bands of colour, which, along with a white highlight band, serve to reinforce the cylindrical and reflective nature of the object.

When drawing **glass**, illustrators and designers often use a series of horizontal or vertical lines to indicate an otherwise clear or transparent surface. This technique is ideal when working with pen or pencil.

Glass absorbs colour, so – when using other media such as markers – represent glass by drawing layers of subtle colour, such as cool greys and light blues. Remember that glass is transparent, so you may need to render what is behind the glass, as well as any reflections. Reflections on the glass appear as white, which can seem to be floating on the surface.



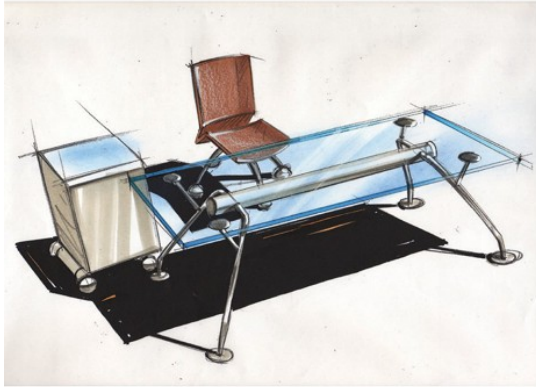

## Plastics

Acrylic materials and plastics often reflect light in the same way as other reflective surfaces. There are, however, many matte plastics that show little or no reflection.

The properties of acrylics and plastics allow moulding and shaping into a wide range of shapes and forms.

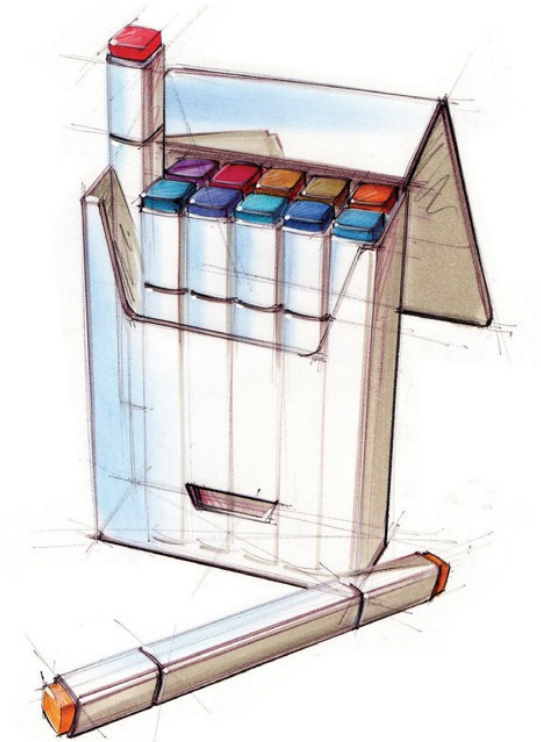

Acrylic materials can be manufactured in a vast range of colours and textures. The colours of acrylic products often appear to be saturated and vivid. When rendering work from the lightest area to the darkest, build layers of colour to achieve a saturated appearance.

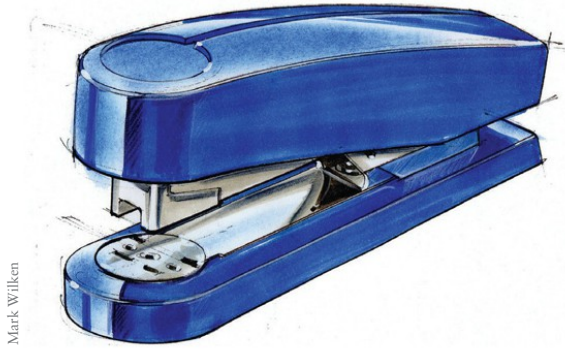

Mark Wilken

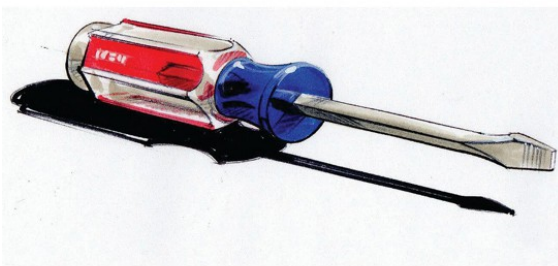

Leave some areas completely white to represent reflections and suggest form. Although plastics are not as highly reflective as metallic surfaces, there will always be highlight areas, and these should be indicated.

## Eco materials

Eco materials include products that are made from recycled components or materials. They often feature colours and textures that are natural and that suggest an ecologically sustainable manufacture. Often, eco products are packaged in recycled substrates such as unbleached card or paper. Eco products tend to lack the glossy surfaces that traditional products might favour. In rendering eco products it is advisable to utilise a muted palette of browns and greens and focus on representing matte surfaces with little reflective qualities.



The rendering of eco designs generally focuses on the recycled nature of the materials, suggesting natural or fibrous textures rather than polished, shiny surfaces.

## Composites

Composites are the combination of two or more materials, which together produce a new material. Composites are often created for their strength and durability. Examples of composite materials include concrete, fibreglass, carbon fibre and plywood.



- ▲ Wood composites include those created with plastics. Although they look like wood, they are usually more durable and weatherproof. In rendering composite wood products, it is feasible to feature some of the more reflective qualities of plastic as well as wood grain.

Although composites may appear to have the characteristics of a natural material, there may be slight visible differences. Invariably, as composite technologies develop, it becomes harder to tell the differences between natural products such as wood and wood-look products made with plastics.

Concrete can be polished or left in a natural state so rendering of concrete products will vary according to the design. A polished surface will have reflective qualities.



ISBN 9780170401784

Fibre products, such as carbon fibre, can present with both matte and reflective surfaces so their rendering needs to reflect the characteristics of the design product. The use of some highlight areas can achieve this.



Mark Wilken



Mark Wilken

- ▲ Items such as rubber thongs, with fabric features, offer combinations of textures but may have limited reflection. The challenge is to ensure that the forms appear 3D and not flat.

## Ceramics

Ceramic products can be matte or gloss in texture. The surface qualities of ceramic designs are affected by the glaze and surface detail that is applied. Glazes include gloss, satin or matte but the object may also be left unglazed and in a natural state. Similar to plastics, gloss and satin glazed ceramics reflect some of their environment. Highlights assist in emphasising the areas that are reflective, while light source is key to emphasising the forms. Matte and unglazed ceramic products do not reflect and require thoughtful application of light and dark tones, along with textural details to appear three-dimensional.

Mark Wilken

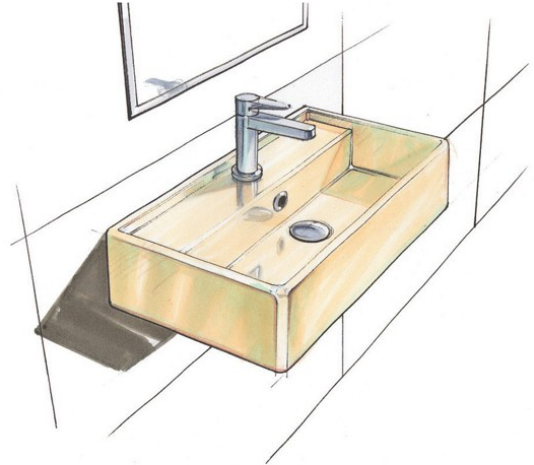

Mark Wilken



Mark Wilken

### VIDEO DEMO: RENDERING



Learn how to render objects to represent different textures and materials. Go to <http://nelsonnet.com.au> and use the code at the back of your book to log in. Click on 'Resources', then go to Chapter 2, page 29 video.



# VISUALISATION AND PRESENTATION DRAWING

CHAPTER

3

---

## In this chapter:

+ Visualisation drawing .....	62
+ Presentation drawing .....	64
» Environmental design .....	64
» Communication design .....	66
» Industrial design .....	67

## Learn the language

digital drawing methods

illustration

manual drawing methods

mark making

sketching

visualisation

You will find helpful tasks related to drawing and rendering in Part B and throughout *Nelson Visual Communication Design VCE Units 1–4 Workbook, Edition Three*.

---

## VISUALISATION DRAWING

**Visualisation** drawing is the drawing we do when creating new ideas. **Sketching**, freehand drawing and even doodling are all approaches to getting ideas onto paper. Combining many of the techniques already covered in Chapters 1 and 2, including 2D methods and rendering, visualisation drawing is the most efficient way of visually expressing an idea or concept; it is an opportunity to get ideas down onto paper before they vanish. Designers are often 'visual thinkers' who find the best way to express a concept is through images

rather than words alone. Whether it is a logo, a webpage layout or even a building, very often the starting point is a pencil and piece of paper.

Visualisation drawing often makes use of traditional media and methods but digital sketching is an equally valid means of getting ideas into visual form. Use of technology such as a stylus and tablet or a responsive screen enables a designer to draw directly into design software. When away from their desk, designers can use these software products to visualise ideas onsite or at client meetings. Using cloud storage, designers can create and access ideas from any location.

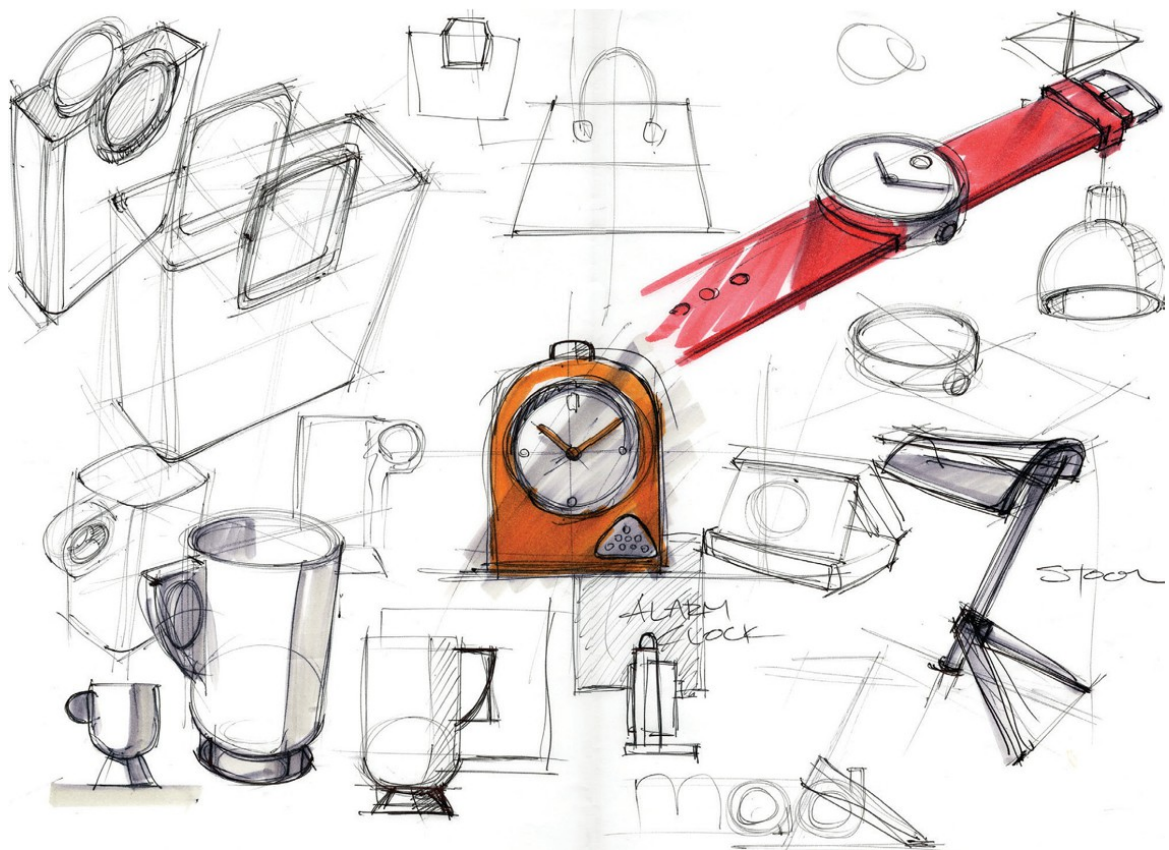

- ▲ In the creation of **illustrations** for this book, designer Mark Wilken completed sketches during the briefing process. These sketches assisted Mark and ensured that he and the author had the same understanding of what was required for each illustration.

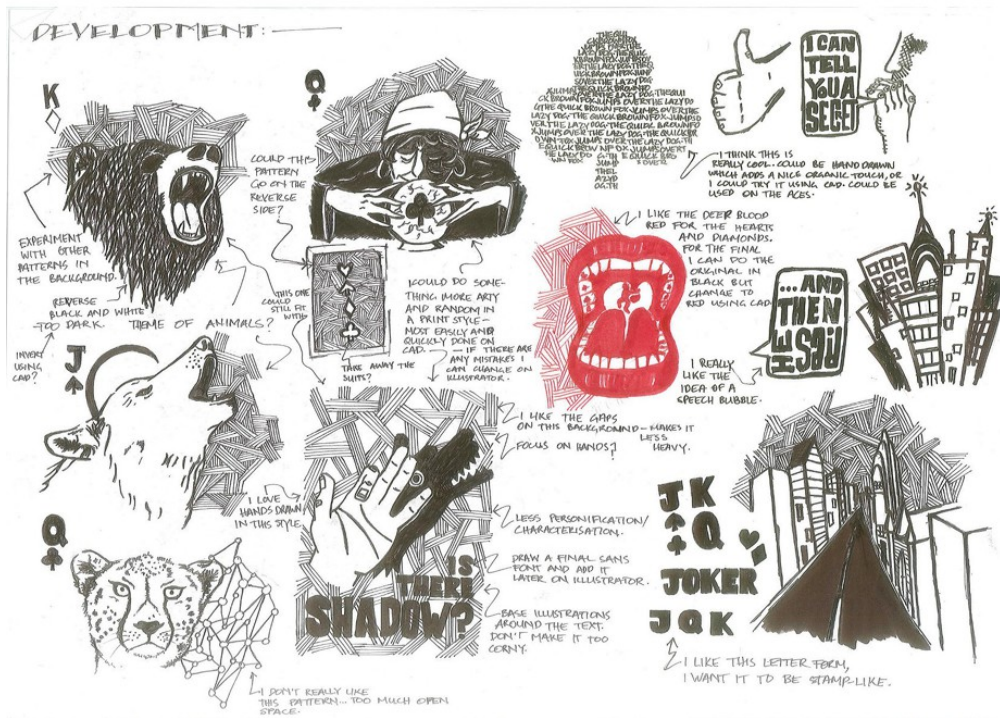
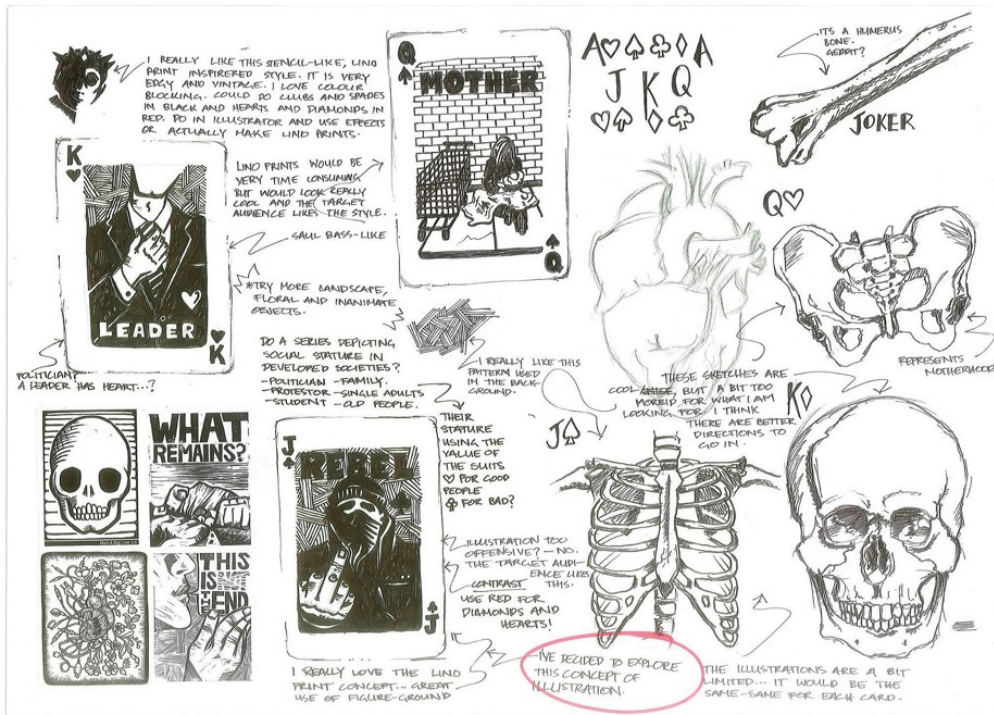

▲ Visualisation drawings for a set of collectible playing cards





▲ New technology allows designers to access their ideas from any location.

One of the barriers to visualisation drawing is the dreaded 'blank page syndrome'. For designers and design students, the first efforts at **mark making** can be made more difficult by the pressure of deadlines and expectations. There are many methods to help overcome the blank page and the often closely associated procrastination.

### TIPS FOR VISUALISATION DRAWING (OVERCOMING BLANK PAGE SYNDROME)

1. In many instances, it is the blankness of the page or screen that is most daunting. Address this by adding something to the page/screen such as a border, inspiration image or word list.
2. Start with a question. At the top of the page ask a question about the design brief such as, 'What if the object/design was soft/sharp/curved?', etc. 'What if?' questions are great thinking tools and can prompt unexpected directions (see SCAMPER in Chapter 9 for more).
3. Ideally, you will have completed research of your target audience, so use an example of your target audience and imagine them as a person with a name. Ask 'What would Sophie or Stephen like?' (see Chapter 10 for more information about working with Personas).
4. At the top of your page specify a single design element or principle,

for example, **SHAPE** or **CROPPING**. Initially restrict yourself to drawings of the element or principle; before you know it, you'll have expanded on your simple starting point by the time you complete the page.

5. Creative people often come up with ideas when they are not sitting at a desk. Be open to ideas that come at other times. Draw a quick sketch or take note (written or record on your phone) of your idea so that you can refer to it later. You might find that some drawings in your development work were devised during other classes.

## PRESENTATION DRAWING

Any of the drawing methods and techniques covered in this chapter are suitable for presentation, within the appropriate context. The initial purpose of a drawing will often define where it is finally applied. Sometimes a drawing will be required to communicate what the final product will look like; production and manufacturing costs can be high so drawing enables a client or user to see the design product without actually touching it. Photorealism is required in some areas of design while others use the loose qualities of freehand drawing to convey the characteristics of a design.

## ENVIRONMENTAL DESIGN

It is important for architects, interior architects and landscape architects to convey their ideas to clients in a clear and accessible manner, given the scale of design projects in their respective fields. The presentation of design concepts to clients ensures that there is a common understanding shared between designer and client about the appearance of the final design. Computer-aided design is often used to enable a client to visualise the finished three-dimensional space; fly-throughs and rendered 3D models help with this process.



◀ This illustration of a home interior is used to promote a new housing development. The representation of a dwelling in this way allows the viewers to imagine themselves within the environment and can assist in marketing a space that does not yet exist. In environmental design areas, the representation of space in this way enables the end user to visualise a three-dimensional space more easily than they might from a plan.

Examples of presentation drawings for environmental design include:

- + architectural drawings
- + 3D scale models
- + multimedia
- + maps
- + diagrams
- + concept presentations
- + plans
- + elevations
- + digital 'walk-throughs'
- + mood boards
- + brochures

### DESIGN REQUIREMENTS

The earthy colours of my design are meant as a way to connect one with nature, or the earth and consequently, themselves as they immerse themselves in the moment, in the touch and feel and smell of the garden.

My design addresses privacy through the use of the walling behind the waterfall and also the use of the golden weeping willows to shelter the copper table beneath. The egg seats are also used as a form of privacy as they are closed in and are "covered", essentially. It addresses peacefulness through the use of colours, the meditation circle and the water feature – the natural aspect of the garden is used to convey this sense of peace. Spaces for meditation in the design include the meditation circle and also the sand pit, which allows the occupant to do something with their hands, allows them to immerse themselves in the texture and the feel of sand. The egg seats could also be considered as meditation spaces, however its primary purpose is privacy.

The meditation circle provides an outlet for those who have trouble meditating in a closed environment and is big enough so that the occupant is not dizzy but instead allows them to focus.

The sand surrounding the waterfall act as a sandpit, or similar for those who wish to create whilst around the trickles of water as sand or tangible objects that one can shape can help make one feel relaxed.

### KEY FEATURES

Key features of my design include the willow trees added (golden weeping willows are preferable as they appear like fairy lights), the circular wooden table/bench, the small round copper tables, the various potted plants (large, soft and leafy), the water feature (which encompasses moss and rocks of various sizes in a waterfall inspired visual), egg seats (which are to hang from the trees), a meditation circle, bi-fold paneled doors for the kitchen out to the garden, sand, stepping stones (which are surrounded each by colourful flowers) and the clear/glass deck.

The various potted plants on the deck are there for the occupants to be able to surround themselves with their senses and to be able to be "in the moment" or to be able to step into a mindful mindset. The sense of touch is therefore crucial, and large leafy and soft/furry plants are to be considered, amongst colourful or aromatic flowers.

The smaller tables inspire smaller groups, if they would like to have private chats or would rather not be in a big group, or out in the open) hence, it is near the willows, so that occupants may feel relaxed or comfortable whilst talking/communicating.

The egg seats provide privacy for those who wish to have solitude and can also be used for sleeping (depending on size). Cushions should be provided for these, however it would be best if the cushions were kept inside. Pathways to avoid getting wet.

MINDFULNESS GARDEN DESIGN CONCEPT

CATHERINEYEONG

▲ Presentation drawing of a landscape design concept for a mindfulness garden. The plan view and annotations help to describe the ideas behind this student's creative design.

## COMMUNICATION DESIGN

Communication design is a broad area and many different presentation methods are used to depict finished concepts. As in other design fields, communication designers may use digital software to present final concepts. Web designers, motion graphics specialists and multimedia designers use appropriate software products to depict the appearance of a static or interactive design. Print designers may use a 'digital storyboard' featuring 'dummy text' to display the arrangement of pages in a publication such as a magazine. Computer-aided design tools enable designers to combine the elements of a design and to

create presentations without the expense of printing large quantities of paper or other materials.

Examples of presentation drawings for communication design include:

- + maps
- + packaging
- + symbols
- + advertising
- + charts
- + logos
- + illustrations
- + brochures
- + freehand drawing
- + posters
- + diagrams
- + publications
- + infographics
- + clothing
- + signage
- + exhibition displays
- + multimedia
- + motion graphics.



▲ Designer Lucy Boehme used a range of templates to help illustrate the applications of an identity design. Presented as part of a final year Visual Communication Design folio, the imagery helps to describe the likely contexts and functions of the design. Using CAD software such as Illustrator, Photoshop and InDesign enables designers to create mock-ups that convey enough visual information for a client to visualise a design outcome.



Alanna Sharp

- ▲ Identity design for a cosmetics brand, created digitally from multiple watercolour shapes and handwritten type.

## INDUSTRIAL DESIGN

The presentation of finished product designs often relies on digital software such as 3D modelling programs. Examples include Rhino, Solidworks and Autocad. This software produces rendered photorealistic imagery of a product and can enable a designer to assess the success (or failure) of a design and evaluate it in terms of the original design brief without going to the expense of production and manufacturing. Final product drawings may be used to communicate with a client or for promotional purposes. Products and constructions are often presented in this way, from small domestic appliances to architectural structures and motor vehicles.

Examples of presentation drawings for industrial design include:

- + 2D and 3D drawings
- + rendered concept sketches for client presentation
- + engineering drawings
- + concept presentations
- + 3D digital scale models
- + diagrams
- + motion graphics



Andrew Juchnevicus

- ▲ Presentation drawing of eco drink bottle concept



- ▲ Industrial designers are often skilled in freehand sketching to present the form and appearance of designs.

**CAMON STATIONERY**

# STITCH - THE ECO STAPLER

THE STITCH STAPLER CUTS OUT A SMALL STRIP OF PAPER, BENDS IT OVER AND FASTENS IT IN A SLIT THAT IT CREATES. IT USES NO STAPLES AND CAN BIND UP TO 6 SHEETS OF PAPER.

**BENEFITS OF STITCH:**

- NO METAL AND PAPER WASTE
- SAVE MONEY ON REFILLS
- CHILD SAFE
- PAPER CAN BE SEPARATED AFTER STAPLING
- NO MORE PAPER JAM AND UGLY HOLES
- REUSEABLE

STITCH IS A GREEN ALTERNATIVE FOR TRADITIONAL STAPLERS. PERFECT FOR HOME, SCHOOL AND OFFICE USE. AVAILABLE IN GREEN, ORANGE, BLACK AND WHITE.

**ERGONOMIC DESIGN**  
STREAMLINED, LIGHTWEIGHT AND PORTABLE. DIMENSIONS 60 X 60 X 50 MM

**DURABLE ABS PLASTIC**  
GOOD STRENGTH AND IMPACT RESISTANCE. RELATIVELY LOW COST.

Nhu Duong

▲ Industrial design. This student used a combination of drawing, rendering and computer-aided design to lay out her concept. Drawing is an ideal means of conveying the form and appearance of products without the time or expense of a model/prototype. The importance of effective three-dimensional drawing skills are evident in this example.

## CHAPTER RECAP



- 1 For each of the following scenarios, identify how visualisation drawing might be applied.
  - a A communication designer discusses possible ideas for an identity design during a meeting with a new client.
  - b At an architectural studio, several designers discuss how a dwelling might be positioned within a given landscape to maximise sun exposure.
  - c An industrial designer devises alternative design responses to the form and appearance of a new design for a screwdriver.

- 2 Explain how visualisation drawing might be applied at the following stages of the design process:
  - a research
  - b generation of ideas
  - c development of concepts.
- 3 Suggest appropriate presentation drawings that might be applied to the following:
  - a the design of a concept for a baby bottle
  - b the design of stage sets for a musical theatre production
  - c the design of landscape to be created as part of wildlife conservation park
  - d presentation of design concepts for the user interface of a car ride sharing app.



# PURPOSES OF VISUAL COMMUNICATIONS

CHAPTER

4

---

## In this chapter:

+ Purposes of visual communications .....	70
» Purpose: to advertise .....	70
» Purpose: to promote.....	71
» Purpose: to depict.....	71
» Purpose: to teach.....	72
» Purpose: to inform .....	73
» Purpose: to identify .....	74
» Purpose: to guide .....	74
» Other purposes of visual communications .....	75

## Learn the language

content	impact	secondary purpose
design fields	multipurpose	target audience
function	primary purpose	wayfinding

You will find helpful exercises and tasks related to purposes of visual communications in Chapter 3 of *Nelson Visual Communication Design VCE Units 1–4 Workbook, Edition Three*.

---

# PURPOSES OF VISUAL COMMUNICATIONS

All visual communications have a purpose, and that purpose has a major impact on the **content** and appearance of the visual communication. It will define the content of the visual communication and establish where and how the visual communication will be seen, who will see it, and how often.

The purpose of a visual communication might be to advertise, promote, depict, teach, inform, explain and/or guide. Often, a visual communication will have more than one purpose, but it is usually possible to identify these as the **primary purpose** and **secondary purpose** or purposes. For instance, a poster advertising a music festival may include the date and time, ticket prices and booking information, along with a map of the location to guide the attendees. The primary purpose of the poster is to advertise the music festival and sell tickets, but the secondary purposes, which inform and guide, are also important to the effectiveness of the visual communication.

## PURPOSE: TO ADVERTISE

Visual communications are considered advertisements when the primary **function** is the presentation of a product or service. Generally speaking, advertising

suggests a commercial outcome such as the sale of a product. An advertisement may not necessarily feature a price but its function, ultimately, is to ensure a sale of some kind.

Advertising and promotion are terms that are often used in partnership, particularly in the case of an event. Advertisements that feature information about the event as well as time, date and location address multiple purposes. In order to understand what the primary and secondary purposes are, look closely at visual communications and consider how the content and visuals create the hierarchy. In designing your own advertisement, consider the hierarchy of your visual message. Is the product or brand most important? Is the price a high priority?

An advertisement may use a 'tagline' or slogan, a recognisable character or personality, brand identity, colours and imagery, or combinations to create memorable content. Branding of products and services is a significant investment for many businesses and organisations. A brand may represent a philosophy, lifestyle and culture that have strong appeal to targeted audiences. Advertisements for a freshly launched Apple iPhone are distinctive in that they offer an image (usually taken by the phone camera), perhaps an image of the product itself and the Apple logo, all on a clean, white background. Little text and no price information are featured but the message is very clearly targeted at those viewers who invest in the latest products from the company.



The Food Chain is a not-for-profit cafe that is dedicated to doing a small part to help better society. The Food Chain gives all profits to Farm Africa, The Foodbank, The Sustainable Table, and Heifer International. These charities are focused on food, and are committed to reducing poverty all over the globe. The cafe attracts like-minded people who are environmentally conscious and value making a difference.

The Food Chain is located in Collingwood, so the interior needed to reflect current trends and appeal to the style preferences of the surrounding community. An inviting and rustic interior was created to bring people together with good food and coffee, and a relaxing place to be. The interior has a simple colour palette using predominantly greys and whites, which allows the existing brick to feature.

The interior reflects an industrial and contemporary style. The neutral grey tones, along with the comfortable textures and patterns of the furniture to stand out. The use of dark wood floors create richness and warmth in the interior. Large windows allow for natural light. The hanging light fittings make the high ceilings a real feature in the space. The Food Chain has a rustic and comfortable mood that may become the social heartbeats of Collingwood.

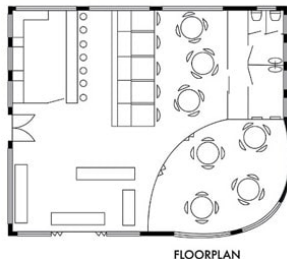

FLOORPLAN



INTERIOR PROJECTED VIEW



Olivia Sherwood

- ▲ The primary purpose of this design for a cafe is to depict the layout and appearance of the space. However, there are several secondary purposes that have been considered by the student; the presentation text informs viewers about the cafe and the plan view explains the functionality and proportions of the space.



Alamy Stock Photo/Kay Roxby



Getty Images/Dan Kitwood

Advertising may use: illustration, freehand drawing, signage, multimedia, postcard, packaging, logo, billboard, brochure, poster, publication, clothing, exhibition display, photography.

## PURPOSE: TO PROMOTE

Visual communications that promote are often used for events, organisations, performances or the raising of awareness. These visual communications may be required to convey a message about something intangible, such as a belief, cause or philosophy. Promotion and advertising are often intrinsically linked but promotion, unlike advertising, does not always have a commercial imperative. In your own designs for promotional visual communications, consider the context of the design. A political protest poster, for instance, may need to be bold, assertive and emotive while a social media promotion for an art exhibition may need to capture the visual style of the artwork and entice the viewer to click through to further information. As with all visual communications, the use and function of the design will often dictate the quantity and style of visual and written information.

### MORNINGTON REAL ESTATE

The  
city  
market

WOODLEIGH MAKERS MARKET  
FRIDAY 25 NOVEMBER  
4PM – 8PM

ARTWORKS JEWELLERY FOOD  
HANDCRAFTS GIFTS HOMEWARES

MORNINGTON 206 MAIN STREET T 9764 5532  
W MORNINGTONREALESTATE.COM.AU

Sign Board printing courtesy  
PENNSLA PROPERTY SIGNS

Zoe Draper

▲ A sign promotes an artists/maker's market and informs passers-by of the main features of the event. The vibrant and quirky, hand-drawn identity emphasises the artisan nature of the market stalls.

Promotions may use: illustration, freehand drawing, signage, multimedia, postcard, packaging, logo, brochure, poster, publication, clothing, exhibition display, photography, symbols and icons.

## PURPOSE: TO DEPICT

Depiction of visual information is a very common purpose in visual communication design; the presentation or illustration of visual information is the primary concern. In some cases, there may be no message other than the visual details of the design product itself. Visual communications in the fields of environmental design and industrial design often focus on the depiction of an actual or conceptual product or space. Likewise, communication designs may depict images and/or typography that serve to enhance, emphasise or deliver a message.





▲ Law Architects used the CAD-generated drawing of a proposed school building to depict the forms and features for the client.



▲ Professional architectural photography depicted the finished building and was used for award submissions and promotional purposes.

Visual communications that depict may feature: map, symbol, chart, illustration, diagram, signage, multimedia, packaging, instrumental drawing, freehand drawing, 3D model, brochure, poster, postcard, billboard, publication, photography.

### PURPOSE: TO TEACH

Visual communications that have the primary purpose of teaching are used when the outcome of viewing is one of learning. Visual communications in this category are often used to explain concepts that are more easily understood with visual stimulus. Complex issues, step-by-step instructions and significant events can be better understood with visual diagrams. Many

textbooks, online university programs and educational motion graphics use diagrammatic visuals to assist learning and recall.

#### LINK: TEDEd



Created by the group behind TED and TEDx talks, TEDEd is a learning facility that makes use of engaging and informative visuals and animations to explain a wide range of topics from dense philosophical issues, historical events and curious questions. To link directly, go to <http://vcd.nelsonnet.com.au>.

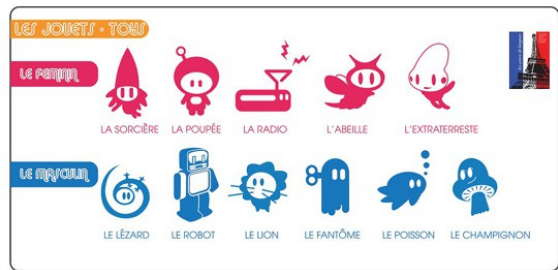

▲ This illustration helps new language learners.

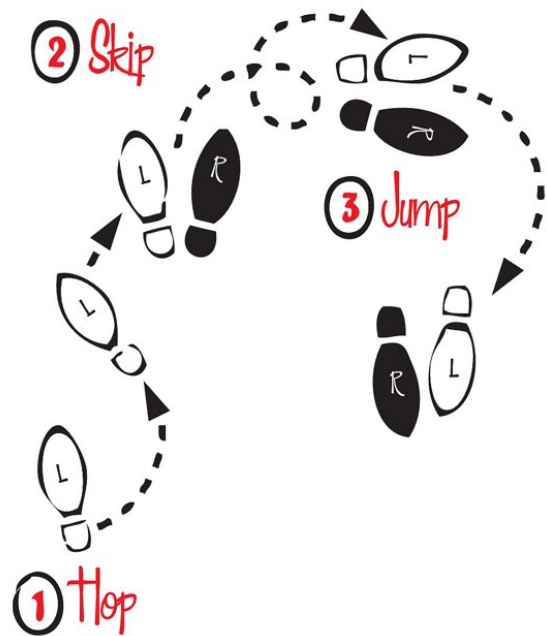

▲ This diagram helps to teach dance steps.

Visual communications that teach may feature: brochure, poster, publication, multimedia, illustration, instrumental drawing, freehand drawing, map, symbol, chart, diagram, graph, 3D model.

## PURPOSE: TO INFORM

Visual communications that inform are used when conveying information that is pertinent to a specific audience and leads to the understanding of a process, event, concept or opinion. Expressing a message that leads to an understanding by the **target audience** is the primary requirement. Like teaching or educational graphics, an informative visual communication may be able to condense complicated information into a simple, visual format. This categorisation of visual communications is extremely broad and might range from the design of the website or print edition of a newspaper to a simple but very important STOP sign!

### Vehicles turning right

Vehicles turning right are able to enter any lane unless there are road markings indicating how the turn is to be made.

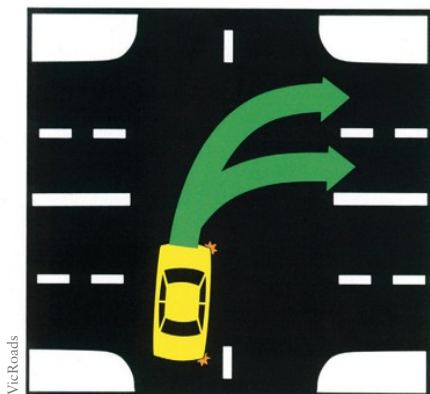

VicRoads

▲ Diagrams explaining road rules from VicRoads

Informational visual communications may use: app, symbol, chart, illustration, freehand drawing, diagram, graph, multimedia, 3D model, brochure, poster, postcard, publication.



▲ Local council signs informing park users of regulations.

### Give way to pedestrians when crossing a slip lane

Drivers must always give way to a pedestrian when crossing a slip lane.



VicRoads

## PURPOSE: TO IDENTIFY

Visual communications that identify, often define the visual identity or characteristics of a product, place, organisation or event. A brand identity is a valuable and powerful tool for an organisation or business. Where it is seen, how it is used and who may use it are often tightly controlled and regulated by a style guide. Identity in visual communications may also manifest in the representation of specific information; a recognisable ‘tick’ to indicate a healthy food option, or a ‘star’ rating on a domestic appliance help consumers make informed choices.



Visual communications that identify may include: logo, symbol, icon, signage, map, diagram, poster, brochure, webpage, multimedia, technical drawing.



Lawrence Curtis

▲ Using a consistent visual language of colour and type, these swing tags help to identify different snowboard sizes.

## PURPOSE: TO GUIDE

Used to assist in establishing and identifying a location or area, visual communications that guide include **wayfinding**, mapping and signage systems. More than simply maps, visual communications ensure navigation is clearly articulated and helpful for users. Signage and wayfinding is an important part of all **design fields** and



Buro North (creators of the wayfinding signage) with contribution from Jane Resieger

▲ Illustrator Jane Resieger was commissioned by Bates Smart Architects to use illustration to distinguish each level of the Royal Children’s Hospital. Each floor of the hospital is **identifiable** by distinctive coloured images that create different visual environments on each level. The illustrations depict ground-dwelling creatures on the lower levels to birds and the sky on the uppermost levels.

often requires designers from many disciplines to work together to create effective solutions.

Visual communications that guide can range from complex road maps to airport signage. Some systems, such as road signage have strict controls over how information is conveyed. Wayfinding within a building or organisation may also be unified by use of similar design elements such as colour, shape and form.



Baro North



Designer: Elise McKenzie, Dare to Fly

Visual communications that guide may feature: map, symbol, diagram, signage, wayfinding, illustration, freehand drawing, multimedia, brochure, poster, 3D construction.

## OTHER PURPOSES OF VISUAL COMMUNICATIONS

There are many reasons that visual communications are applied and, as mentioned, most design features more

than one purpose. It is impossible to provide a definitive list of all the purposes that visual communications fulfil but it is important to understand that they may be varied and intersecting. The purpose of a design is often outlined in the design brief and will be affected by the design field. Of course, there are many functions that can be identified in each design area but a selection of common functions are listed here.

Consider visual communications that you have seen or created; how many additional purposes have you identified?

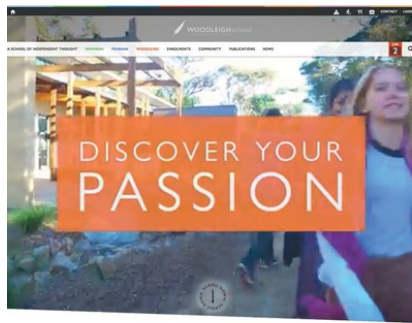

Adam Liddiard, Designer

▲ A complex design for a website addresses multiple purposes. The information contained within the site may depict, promote, advertise, explain and inform. In addition, the functionality of the site must be suited to a range of devices which influences the arrangement of visual information.

▼ Functions of the design fields

Design field	Possible function	Example
Industrial design	to facilitate to transport to display to protect to interact  to accommodate	domestic appliance motor vehicle shelving packaging digital media product furniture design
Environmental design	to shelter  to engage to accommodate  to make  sustainable to beautify to decorate to inspire	public transport shelter shelter playground design residential building commercial building  landscape design interior design public building, memorial or display space
Communication design	to attract to visualise to persuade   to explain to manipulate  to illustrate to highlight to decorate  to guide to instruct to symbolise to communicate to entice to persuade	advertisement infographic online fundraising banner advertisement diagram editorial image or illustration mural signage textile design or pattern map visual warnings icon or symbol webpage packaging advertisement

## CHAPTER RECAP



- 1 What are the main differences between advertising and promotion? Find examples of each and indicate the similarities and differences. Cite your sources.
- 2 This chapter briefly touched on 'branding'. Identify a popular brand and investigate how that brand is represented in different contexts.
- 3 Source a wayfinding system in a place or building. Using drawing or photography (with permission) document how the system is adapted to different spaces and contexts.
- 4 Create your own list of purposes and find examples of each. Cite your sources.
- 5 Find products that are accessible at home, such as packaging in the pantry or bathroom cabinet. Photograph a diverse range of different items and either print and annotate by hand or digitally annotate using the following prompts:
  - a Identify the primary and secondary purpose of each visual communication.
  - b Identify all additional purposes that are evident on the visual communication.
  - c Describe how the visual communication has been designed to achieve its purpose/s.



# DESIGN ELEMENTS AND DESIGN PRINCIPLES

CHAPTER

5

## In this chapter:

+ Design elements .....	79
» Colour .....	79
» Form .....	84
» Line .....	86
» Point .....	88
» Shape .....	89
» Texture .....	91
» Tone .....	93
» Type .....	95
+ Design principles.....	97
» Balance.....	97
» Contrast .....	100
» Cropping .....	103
» Hierarchy .....	104
» Figure-ground .....	105
» Pattern .....	107
» Proportion .....	110
» Scale .....	112

## Learn the language

+ Design elements				
colour	line	shape	tone	
form	point	texture	type	
+ Design principles				
balance	cropping	hierarchy	proportion	
contrast	figure-ground	pattern	scale	

You will find helpful tasks related to this area of visual communications in Chapter 2, *Nelson Visual Communication Design VCE Units 1–4 Workbook, Edition Three*.

# DESIGN ELEMENTS

## COLOUR

Colour is a very powerful **design element**. For 90% of the population, colour is perhaps the most dominant and influential of all the design elements. Colour attracts us, warns us, calms and soothes us – it can influence our moods and our behaviour.

In traditional colour theory, there are three pigment colours that cannot be mixed or formed by any combination of other colours. All other colours are derived from these three colours: red, blue and yellow. Mixing the primary colours creates the secondary colours of green, purple and orange. Mixing the secondary and primary colours further creates multiple tertiary colours. Hues of all colours can be modified via the addition of black and white.

### The colour wheel



### Primary colours

The primary colours are yellow, blue and red.

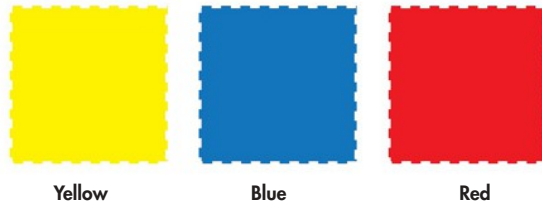

Yellow

Blue

Red

### Secondary colours

The secondary colours are green, orange and purple. Secondary colours are created by mixing combinations of primary colours.



Green

Orange

Purple

### Tertiary colours

Tertiary colours are created by mixing a primary colour and a secondary colour.



Yellow-green

Blue-green

Blue-purple



Red-purple

Red-orange

Yellow-orange



## Harmonious colours

Also known as analogous colours, harmonious colours are colours that appear side by side on the colour wheel. When used together in a composition, they create subtle variations.

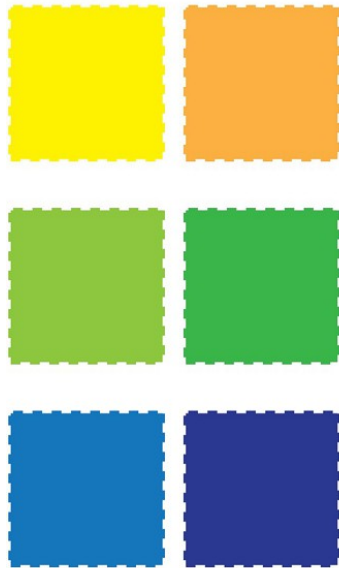

## Complementary colours

Also known as contrasting colours, complementary colours are opposite and separated by colours on the wheel. These colours are often used together to create **contrast**. Colours that are direct opposites on the colour wheel can provide the strongest contrasts and draw the viewer's eye to key information within a composition. Complementary/contrasting colours can create deliberate tension in a composition, which might be required for emphasis or to create a sense of dynamic visual force. They can sometimes appear to vibrate – for example, red text on a blue background – and are deliberately used to create such an effect in some artwork.

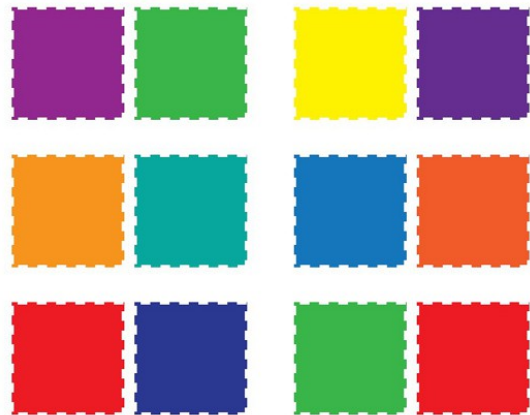

## The colour wheel in practice



Monochromatic (black and white)



Primary colours



Secondary colours



Tertiary colours



Harmonious colours



Complementary (contrasting) colours

We can look at colour from many directions, including its psychology, its symbolism and the extraordinary communicative power that colour holds. Though it is not possible to fully understand the significance and

symbolism of every colour, it is essential to appreciate that colour has many facets, and to understand the influence it has in our lives.

Colour surrounds us – in language, in advertising, in fashion, and can even affect our behaviour. We quickly recognise that red means ‘Stop’ and green means ‘Go’. When the use of colour challenges our understanding of its meaning, the message can become very confused. This can be seen in the illustration below.



To fully utilise the power of colour, designers need to understand its significance in many contexts, including that of culture. In designing for a specific audience or market, the choice of colour may be influenced by various factors. In Chinese culture, for example, red is symbolic of good luck, and at Chinese New Year you might see streets festooned with red lanterns and red decorations. In China, white is representative of death, so whereas we are accustomed to seeing brides wearing white dresses, such clothing would not be appropriate there – in fact, the colour of traditional bridal attire is red.

Just as we need an awareness of cultural sensitivities in all areas of design, including the application of colour, we also need to understand the emotional power of design elements.

Colour can elicit strong responses from an audience, even though a reaction may be quite subconscious – we are often quite unaware of the influential and persuasive effects of colour. The colours of a country’s flag or the uniform worn by its athletes at the Olympic Games might encourage a sense of patriotism, which manifests itself in emotions such as pride.

As colour stimulates our emotions and senses, it can suggest a wide range of possibilities. Colour might suggest a fashionable and appealing lifestyle, it may soothe and placate, or suggest energy and dynamism.

Colours can also be described as either warm or cool. Blues, greens and purples are traditionally referred to as cool colours, while reds, oranges and yellows are termed warm. Actual temperature has nothing to do with it, but warm and cool colours can describe a ‘feel’ in a design composition.



▲ The two posters pictured use the same graphic elements to promote a festival, yet the use of colour helps to describe the theme and season of the events.

Colour can be used in architecture and interior design to alternatively stimulate and sedate.



▲ The Pixel building in Carlton, designed by Studio 505 Architects, uses vibrant colour on the facade of the building. The coloured panels also function as insulation, shade and solar capture on this six-star energy efficient building.

Some research has shown that hues of pink can have a calming effect, and in fact a colour close to bubblegum pink was used in an American prison to subdue violent and angry prisoners. Schools often choose to paint walls in vibrant colours such as yellow and green, colours that are designed to stimulate learning and creativity.

### COLOUR FASHION

Colour forecasting is big business. Professionals working in fashion, interior design, product design and manufacturing often begin the design of a concept many months – and even years – in advance. Predicting colour trends is therefore very important to ensure that a design is relevant and marketable in the future. Companies such as Pantone, Edelkoort and Fashion Forecast Services provide clients with reports that analyse trends in fashion, accessories, textiles, paint colours and furniture.

FYI



## Colour production

When producing images for print or electronic publication, you will need to have an understanding of the methods of colour production. There are different colour systems that are designed for use on a computer screen and in print. It is likely that at some stage you have selected a colour on your computer screen only to have it print quite differently on an inkjet or laser printer. This is because screen colour and print colour use different systems and interchanging from one to the other will often cause colour change. Tools such as a Pantone colour swatch and colour management software assist in countering the differences. (See later in this chapter for more information about colour modes in digital design.)

### RGB

RGB stands for red, green, blue. The RGB mode, on which your computer monitor is based, defines all

possible colours as percentages of red, green or blue. RGB mode is used for on-screen editing or viewing of graphics.

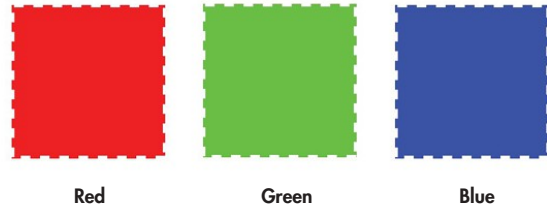

RGB colours are called additive colours because the RGB system involves starting with black and adding coloured light. For example, adding green light and red light gives yellow light, while red plus green plus blue light gives white light.

### CMYK

Known as process colour, **CMYK** divides your images into four colour channels: cyan, magenta, yellow and black, which correspond to the inks used in four-colour printing. When using design software, RGB images can be converted to CMYK but some colour change will occur. CMYK is used by commercial printers to produce full-colour work.

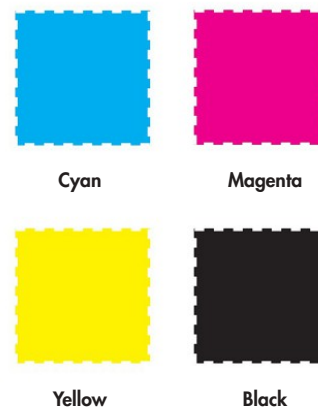

### TIP: RGB AND CYMK

When working with RGB and CYMK colours, it is helpful to use the numeric values for each. This can assist when recreating a colour or when you might need to manually key colour codes from a printed swatch. Most design software will offer a menu to toggle between each colour mode.

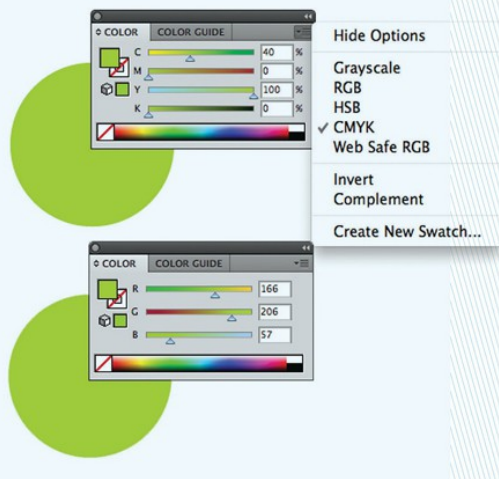

### Spot colour

At times, it is more cost effective to use a colour that already exists in ink form and does not have to be mixed via the CMYK process. Spot colours are premixed colours produced commercially and available for professional use. When using one to three colours in a document or presentation, spot colour can be the most cost-effective approach. Pantone uses the PMS (Pantone Matching System), which is perhaps the most widely recognised spot colour matching method. Designers select the most appropriate colour from printed swatches that show hundreds of colours. They can be confident that the final print will reflect their choice, even though PMS colours often appear differently when they are shown on a monitor as RGB percentages.

### A swatch book of colours



Colour can be:

- + bold
- + subdued
- + vibrant
- + bright
- + subtle
- + warm
- + cool
- + primary
- + secondary
- + tertiary
- + contrasting
- + complementary
- + eye-catching
- + dominant
- + dynamic
- + calming
- + emotive.

Colour can be used to:

- + define space
- + create contrast
- + create **hierarchy**
- + create a mood.



iStockphoto/Evgemy Ivanov

▲ Map of the world showing continents and countries. Visual information can be categorised for easier understanding through the use of colour.

## FORM

**Form** generally refers to objects that are three-dimensional in nature. We readily recognise the forms around us – from the pencil on the desk to the form of the human body. Form is often depicted visually through the application of other elements such as shape and **line**. Form can be rendered to enhance its three-dimensional



Skydeck Chicago

▲ Using **type** and shape, the logo for the SkyDeck in Chicago emphasises the form and height of the Willis Tower (the tallest tower in the Western Hemisphere).

qualities. The addition of shadows and highlights can help us to ‘read’ the true form of an object.

As you know from the physical environment that surrounds you, forms are infinitely varied and range from the geometric and constructed to the organic forms of the natural world. The representations of these forms are similarly varied and can range from the precision of an isometric engineering drawing to a loose and flowing charcoal life-drawing.



Indicia Design, Kansas City, Missouri, USA with permission of The Buckley Group L.L.C

Designers who work with the constructed environment – such as architects, industrial designers and interior architects – constantly experiment with our perceptions of form. Many variables impact on the design of new forms. These variables include:

- + ergonomics
- + structural constraints
- + the environment
- + fashion and trends.

Many professionals involved in environmental design – whether it is landscape, product design or the constructed environment – are heavily influenced by the versatility of form. Take a chair, which is useful for that most basic of functions – sitting down. Yet this deceptively simple, functional object has developed, changed and evolved over the past century into a product that has challenged our ideas about form.

**LINK: MARC NEWSON**

Marc Newson may be Australia's most successful living designer. Newson was born in Sydney, Australia, in 1963 and studied sculpture and jewellery at Sydney College of the Arts. His design expertise spans fashion for G-Star and domestic items for Magis and Alessi to aircraft interiors, automobiles and hotels. Newson's ability to create functional yet unique forms is his trademark. His innovative use of materials is also remarkable. His website provides a comprehensive archive of his extraordinary body of work. You can link directly to his website via <http://vcd.nelsonnet.com.au>.



'BUNKY' by Marc Newson, photography by Tom Vack

▲ A bunk bed design by Mark Newson

**Ergonomics**

Ergonomics is the study of human factors in design. This scientific discipline looks at the functions, limitations and needs of the human body in relation to product design. Ergonomists often work with designers to design products that take into account the physical, organisational and psychological effects on the user.

**LINK: ERGONOMICS**

For more detailed information about ergonomics, visit the International Ergonomics Association website. You can link directly to the website via <http://vce.nelsonnet.com.au>.

**Form follows function**

A phrase by architect Corbusier, which was embraced by the modernists of the mid-20th century, 'form follows function,' suggests that aesthetic considerations should come secondary to the pure functionality of a design product. Many designers believe that beautiful design is only achieved when the successful function of the design is fully realised. Contemporary (and post-modern) interpretations of this phrase are less rigid and many current designs reflect a balance between functionality and decorative elements. A good rule of thumb is to remember that no matter how attractive a design looks, if it doesn't achieve its primary purpose, it is not a successful design.



Animi Causa (www.animicausa.com)



Animi Causa (www.animicausa.com)

▲ Animi Causa 'Feel' seating system. The form of this innovative seating system can be changed in multiple ways by the user. Made from 120 soft foam balls covered with a smooth elastic fabric, the form was inspired by molecular structure.

- Form can be:
- + three-dimensional
  - + organic
  - + geometric
  - + dominant
  - + subtle
  - + tactile
  - + solid
- Form can be used:
- + to define space
  - + to create contrast
- + fluid
  - + graceful
  - + irregular
  - + textured
  - + natural
  - + manufactured
  - + modelled
  - + sculpted.
- + as a model or prototype.



iStockphoto/Evgeny Ivanov

▲ This illustration enables us to understand the structural form beneath the upholstered surface. The linear wireframe and fully upholstered views provide contrast as well as context.

## LINE

Line is a versatile design element using only the dimensions of length and width. In technical drawings, line is integral to the representation of shape and form. Linear details – such as the outline of an orthogonal drawing and the appropriate dimension lines – are represented through lines of varying type.

The purpose or intent of a visual communication can vary through differences in the width or ‘weight’ of line. A fine or light line can suggest a specific technical detail or, in the context of an illustration, a sense of lightness or minimalism. Bold or heavy lines might be used for emphasis or to represent a structure within a given space.

Line can suggest direction and movement. It can draw the eye into a composition and direct it along a path. Used as a border or to define the areas of a composition, line can create structure and stability.

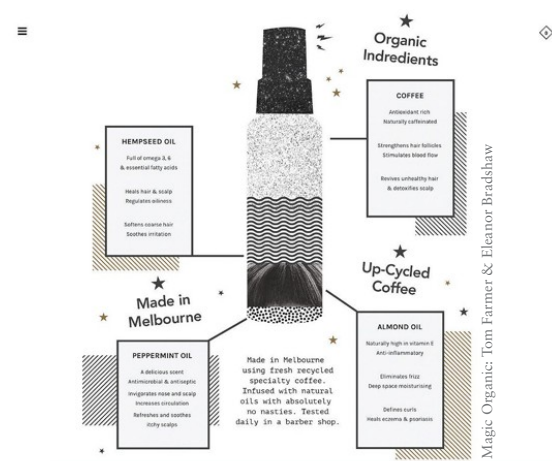

▲ Line is used in multiple ways on the promotional website for Magic Organic Coffee Hairspray. Line leads the eye to key product information and creates patterns that sit behind text to define space and draw attention. Line, along with texture, illustrates the quantity of contents in the bottle.

Used as an illustration tool, line forms the basis of many popular techniques. In relief and intaglio printmaking, line is used extensively in the development of imagery. Linocuts and dry point etching, in particular, lend themselves to the application of diverse line types. When used to render objects, line rendering techniques such as crosshatching create variations in tone and texture, which in turn serve to emphasise form.

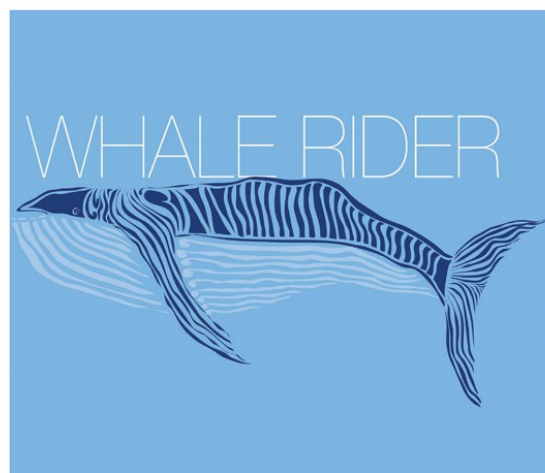

Alanna Sharp

▲ This student applied a highly creative use of line to create pattern and form on a minimalist film poster for *Whale Rider*.

Line can be:

- + broken
- + flowing
- + bold
- + fine
- + medium
- + repeated
- + organic
- + eye-catching
- + dynamic
- + directional
- + static
- + curved
- + straight
- + sketchy
- + freehand
- + precise.

Line can be used to:

- + establish structure
- + create a pattern
- + indicate
- + direct
- + render.

Line can create:

- + contrast
- + pattern
- + formality
- + contour
- + structure.



Gemma O'Brien

▲ The use of hand-drawn line in this work by Gemma O'Brien helps to emphasise type and creates a vibrant and eye-catching pattern.

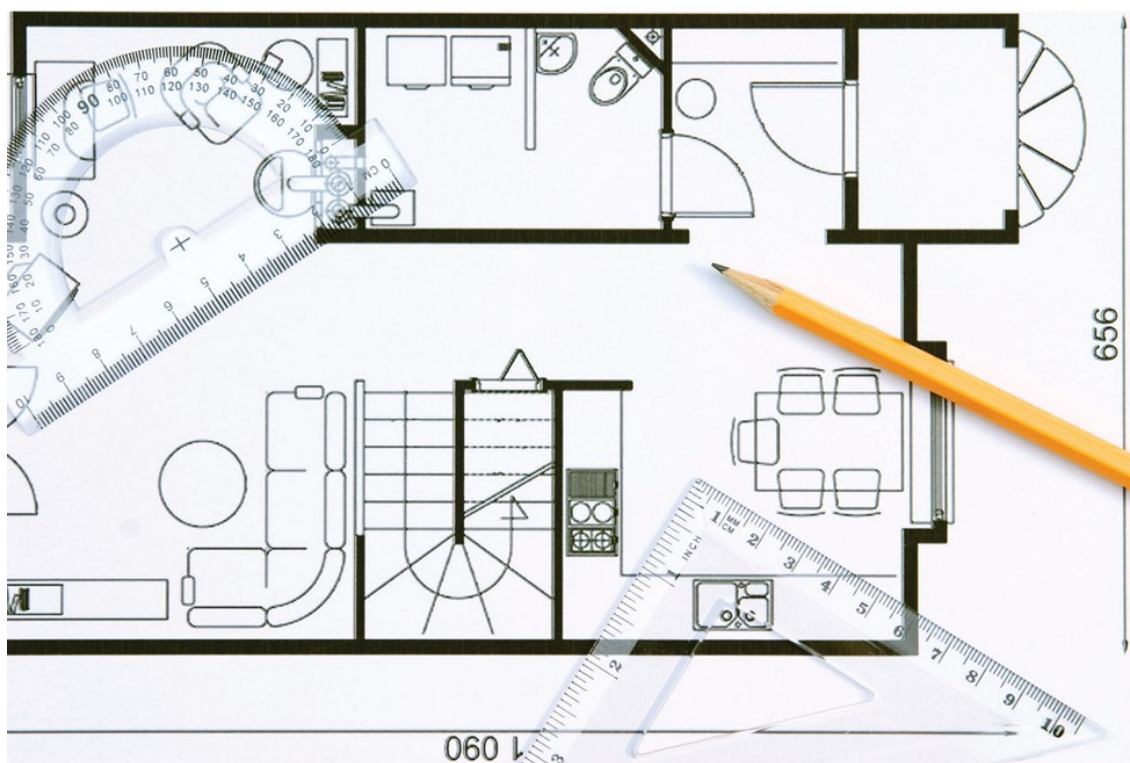

iStockphoto/Nathalie Beauvois

▲ Line qualities vary in architectural drawings. Varying line widths represent specific structural information.



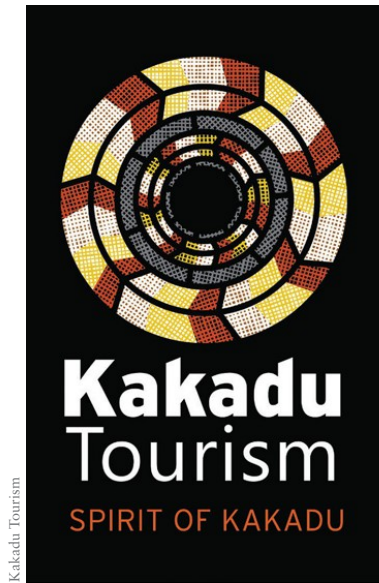

▲ Examples of line use in logo design. Both logos use line as the primary element, but note that the quality of line (freehand or instrumental) makes a significant difference to the visual outcome.

**LINK: VISUAL COMPLEXITY**

This extraordinary website showcases the work of designers who strive to visually represent complex concepts. For many of them the use of line is integral to depicting detailed and involved visual information. Well worth a visit! You can link directly to the website via <http://vcd.nelsonnet.com.au>

**POINT**

Represented as a dot or other small shape, **point** is one of the simplest design elements and is often used as an indicator to determine or define features on a map or document. In mapping (cartography), point is used to indicate places of interest and geographical features. In diagrams or documents, point may be used as part of a bulleted list to identify a series of concepts or statements.



▲ UK illustrator Izzie Klingels' incredibly detailed dot renderings appear in magazines, on music graphics and posters. This image is created entirely from ink dots made with a fineliner.

When used as a tonal element in dot rendering, point can convey the texture and characteristics of an object and express tonal variations effectively.

As an element of a pattern, the repetitive use of point can create designs ranging from simple shapes that define key points within a paragraph of text to complex arrangements of dots that create an image in the style of a halftone screen or pointillist composition.



## VORTECHNICA STRATEGIC MEDIA SUPPORT

Point can be used to:

- + differentiate
- + define
- + separate
- + act as an indicator
- + identify
- + emphasise
- + highlight.

Point can create:

- + a map location
- + a bulleted list
- + dot points
- + texture
- + pattern.

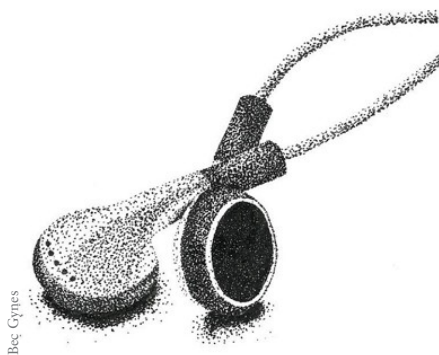

▲ Using the application of point as a technique, dot rendering creates subtly toned and textured illustrations.



▲ Point is often used in mapping to indicate location and places of interest. This map of the Sydney Harbour area uses point to draw attention to significant sights.

## SHAPE

Shape describes representational or abstract shapes that are two-dimensional.

Simple geometric shapes with the dimensions of length and width include squares, triangles, rectangles and circles.

There are limitless irregular or abstract shapes. These might appear as natural organic shapes, or as irregular geometrically based images.

Shape may form the ground in a composition, providing a space for the placement of other elements. Shape is used for emphasis and to draw attention to the figure in a visual communication. Shape may be the figure itself in the form of a logo or symbol.



Shape is an element that is very familiar to us, from the silhouette of the human figure to the shape of a 'Stop' or 'Give Way' sign on the road. Shape can inspire all kinds of reactions in a viewer; the shape of a heart or a cross might provoke an emotional response, whereas the hexagonal shape of a stop sign demands an immediate physical response from the car driver.



- ▲ Road signs use universally familiar shapes. It is the combination of shape and colour that communicate to road users. The yellow diamond is another common shape-and-colour combination that indicates caution.

Symbols are usually two-dimensional and are often based on simple geometric shapes.



## Pictograph

A pictograph is a symbol that is based on a recognisable set of shapes or on a commonly recognised form. For example, the male/female signage used on public toilets is usually pictographic. The forms of the female and male figure are familiar and require no additional text for identification.



The use of shape incorporates the application of other elements such as line or colour. Shape can be created using a range of media (such as paper, fabrics or card) and methods (such as collage or monoprinting). Other design elements such as type, colour and line can be used abstractly to create shapes that increase the visual interest of a composition.

Shape can create:

- + hierarchy
- + pattern
- + background
- + contrast.

Shape can be:

- + two-dimensional
- + solid
- + outlined
- + irregular
- + organic
- + geometric
- + defined
- + cropped
- + symmetrical
- + open
- + closed
- + free form.



- ▲ These logos for Animalyser.com cleverly combines the simplified shapes of animals to create a type-based identity design. The design, by Yiyi Lu, can be adapted for a range of promotional products and merchandise relevant to the brand.



Atelier Art Supplies Pty Ltd

- ▲ The Atelier Art Supplies logo references the shape of an artist's easel within a typographic identity. This addition, with its warm splash of colour, helps to emphasise the core business of the brand, which is art and design supplies.

Identity design is often shape-based. Many logos use shapes to describe concepts, ideas or events. The use of shape often means that a concept is readily transferable to different surfaces. The Born2Fish logo, designed for a fishing club competition team, is an example of a logo that was designed with its future applications in mind. Many designers use templates or 'blanks', such as the hats and sandwich board, to help a client visualise how the logo might be applied to different products and in different contexts.



ISBN 9780170401784

## TEXTURE

**Texture** assists in visually describing the detail of an object, and helps us to understand what an object is made of. It can also help us to recognise and understand the features of the environment in which an object exists.

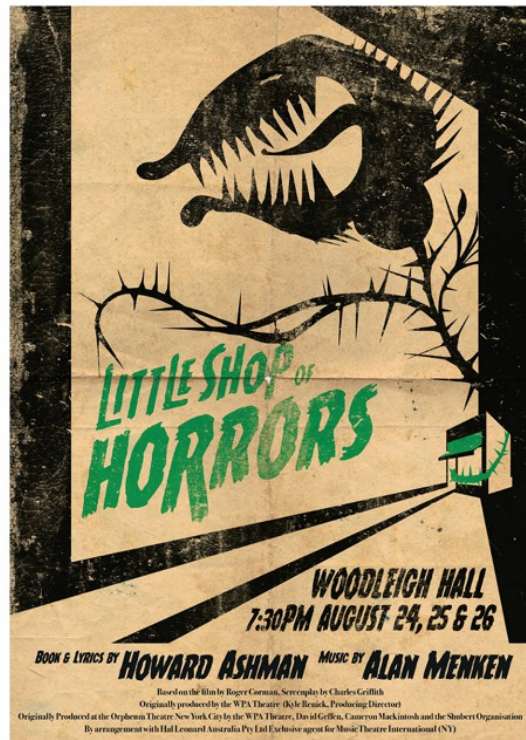

Adam Liddiard

- ▲ Using the texture of aged, folded paper, this promotional poster for a school production of *Little Shop of Horrors* helped to capture the B-grade movie aesthetic of the famous play. In this instance, the texture, colour and imagery were combined to evoke memories of horror movie posters from the 1950s and 1960s.

Texture offers considerable challenges in illustration; it is challenging to visually represent features that we usually recognise through our sense of touch. Representing texture on a two-dimensional

Nelson Visual Communication Design VCE Units 1–4

surface takes some practice and acute observational skills. The key to depicting texture effectively is to take into account how tonal or colour variations can affect the appearance of texture.

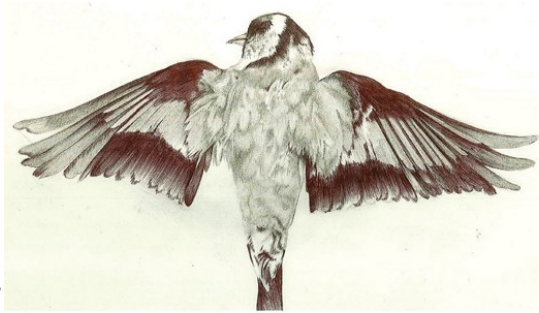

Steph Hosler

- ▲ Drawing from life, this student used a range of pencil grades to achieve the softness of feathers. Tonal variations and careful mark making combine to suggest the clearly identifiable texture of feathers.

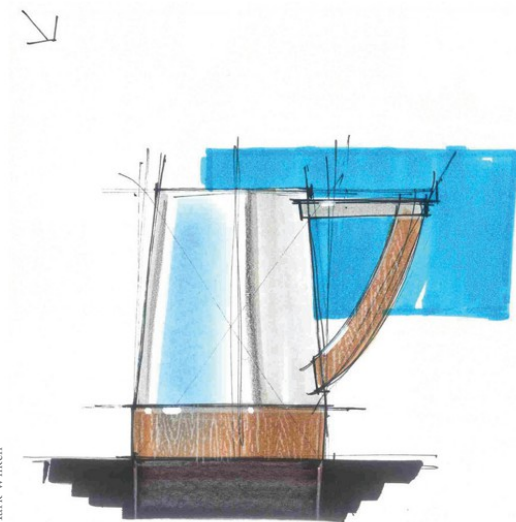

Mark Wilken

- ▲ A quick product sketch, designed to rapidly explain the form and materials of a kettle, makes use of pastel, marker and a texture board to represent metallic, wood and flat surfaces.

Importantly, texture communicates information about the characteristics of objects. Rendered architectural illustrations might depict stone or brickwork, reflective glass surfaces and the foliage of surrounding trees. Such detail communicates information

that would not be available in two-dimensional plans or three-dimensional line drawings alone.



Mark Wilken

- ▲ An architectural sketch, using only line, can help describe the textural elements of an environment such as a stone wall or rendered surface.

Texture can be applied in logo design to reflect the nature of a company or service. Texture can be highly visually suggestive and has the power to communicate complex surface information.

The use of texture is common in logo design as companies ensure that their corporate identity is effective in digital as well as printed formats. Prior to the Internet, very few gradients or textures were used in logo designs as they rarely reproduced well when faxed or photocopied. Now, due to innovations in technology for both screen and print, gradients, fades and a spectrum of colours or hues can be used effectively in branding.



GlitchkaStudios.com



GlitchkaStudios.com

- ▲ Illustrator and designer Von Glitchka takes photographs of textures that he finds, creates vector files and incorporates them into his illustrations.

The texture of a product or its packaging can influence our attitude towards it as consumers. Increasingly, the pursuit of 'greener' product design and packaging has led to an increase in products packaged in recycled materials. These have 'natural' textures that appeal to or encourage an environmentally aware audience.



Greenmark eco packaging range/greenmarkpack.com.au

Textures can appeal to us on a subconscious level. Humans enjoy the sense of touch; the appeal of a fluffy kitten or smooth velvet invites us to touch a surface. A soft texture may imply tenderness or luxury. Alternatively, harsh textures such as jagged edges, barbs or thorns might repel us and may even imply danger.

ISBN 9780170401784

## LINK: TEXTURE PILOT



Texture Pilot is a visual reference library of images designed to assist designers and artists in reproducing textures and materials. The vast collection of images is arranged by detailed categories. You can link directly to the website via <http://vcd.nelsonnet.com.au>

Texture can be:

- |          |              |
|----------|--------------|
| + smooth | + tactile    |
| + glossy | + reflective |
| + matt   | + dull       |
| + uneven | + metallic.  |
| + coarse |              |

Texture can be used to:

- |                  |                              |
|------------------|------------------------------|
| + contrast       | + enhance and describe form. |
| + emphasise      |                              |
| + create pattern |                              |

## TONE

**Tone**, when applied effectively, can enhance the appearance of an object, describe three-dimensional form and provide information about the surface textures of an object.



Prue Edmunds

When discussing tone, you may come across the term 'tonal scale', which refers to a series of tonal values or levels between black and white. Tone describes the play of light and shadow on an object, defining its form or shape.

Nelson Visual Communication Design VCE Units 1-4

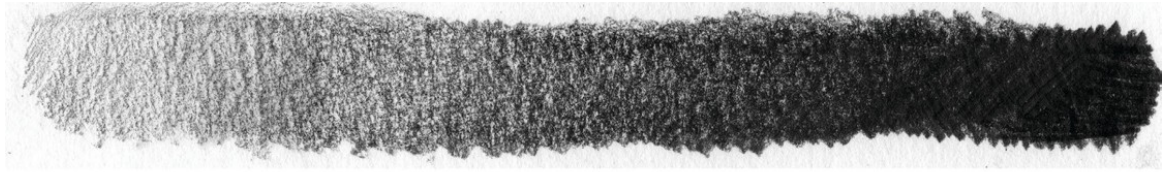

▲ Tonal scale using an 8B pencil

In applying tone to an image, the light source must be taken into account. Ordinarily there will be one primary source of light, which will define the highlight and shadow areas on an object and direct the application of tone.

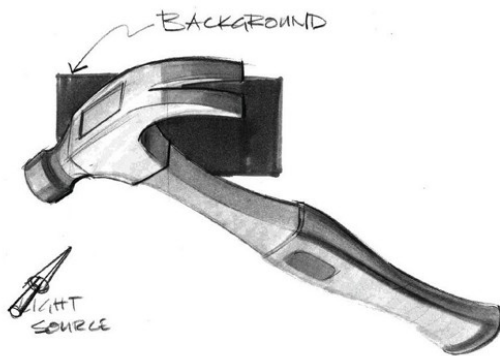

▲ The position of the light source will determine the application of light, medium and dark tones.

In illustrations, the application of tone can influence the mood being conveyed. Cartoonists and illustrators often use tone to emphasise a theme in an illustration. Used for emphasis, tone can create a mood that is dark – or, alternatively, a sense of lightness. Tone can be applied by a range of media and can be created through the application of different rendering techniques such as crosshatching, pencil or marker rendering, and dot rendering.



Johanna Schreiner

### TIP: APPLYING TONE



To apply tone effectively and to create three-dimensional forms, such as the nuts pictured, rely on contrast. Strong contrasts between highlights and shadows create a sense of depth and distance. This, in turn, suggests form. Avoid ‘flattening’ tones into mid-greys; focus on sharp contrasts that can be softened as the image develops.

### QUICKVID: APPLICATIONS OF TONE



Watch and learn how to apply tone using a range of media. Go to <http://www.nelsonnet.com.au> and log in using the code at the back of your student book. Click on Resources and go to page 94.



Thomas Rennie

Tone can be:

- + dark
- + light
- + medium
- + subtle
- + dramatic
- + muted
- + soft
- + harsh
- + defined.

Tone can be used to:

- |             |                     |
|-------------|---------------------|
| + render    | + define            |
| + contrast  | + enhance           |
| + model     | + create form       |
| + highlight | + describe texture  |
| + emphasise | + define structure. |

## TYPE

Chapter 6 covers the language and anatomy of **type** in detail. In brief:

- + Typography is defined as the art of working with type.
- + Typeface refers to a specific style or ‘family’ of type (face is also used).
- + Font has essentially the same meaning as typeface, and was commonly used to describe a typeface of a specific point size. Font has now become a standard term used in electronic publishing often interchangeably with ‘typeface’.
- + The terms ‘letterform’ or ‘glyph’ refer to individual type forms including symbols, numerals and icons, for example, @ # & 1 2 3 A B C.

Type is much more than just text. Type can be used as a decorative device, as the dominant visual element in a composition or as informative text. Type often forms the dominant element in contemporary graphic design. Monogram logos that use type as their primary design device – such as AMP, ANZ, IBM – have distinctive and instantly recognisable identities.



- ▲ City of Melbourne logo, designed in 2009 by Landor Brand Consultancy

A long and rich history exists behind many of the typefaces we use today. Some type styles that we commonly see used in newspapers (and other publications that use large areas of text) date from the Renaissance. There are many type styles, and an Internet search for ‘fonts’ will provide you with thousands of libraries of vastly different typefaces. In making decisions about the use of type, as with other elements, it is important to understand the purpose and context of your design.

## Type style

Some of the most common type styles are:

- |              |                      |
|--------------|----------------------|
| + serif      | + script             |
| + sans serif | + decorative/graphic |
| + slab serif | + handwritten.       |

### Serif

#### Serif

Highly legible, classic and recognisable. Use for body text as serif fonts are easy to read. Contrasts with, and complements sans serif type. Commonly used in newspapers and books.

- ▲ A serif typeface has an extra mark at the end of the vertical and horizontal strokes of the main type. These additional features are known as serifs. Serif typefaces can improve the readability of blocks of text by leading the eye along the line of type, and are therefore used in books, newspapers and other slabs of text.

When used as the dominant type in a composition, serif typefaces can sometimes appear to be traditional and conservative but do allow for easy recognition and reading.

Common examples of serif typefaces are Times New Roman, Palatino and Garamond.

### Sans serif

#### Sans serif

Highly legible at large sizes and contemporary. Easy to read on screen but less so in body text. Contrasts with, and complements serif type. Avoid using for large blocks of text e.g. novel.

Sans serif typefaces lack the decorative features of serif type – ‘sans’ is a French word meaning ‘without’ – and can create a contemporary and non-traditional appearance. Sans serif typefaces can be harder for the eye to cope with in large areas of text, but work very effectively in smaller paragraphs and large headings. The simplicity of sans serif type often makes it suitable for large-scale applications such as billboards, or very small text such as footnotes in a document. Common sans serif typefaces are Arial, Futura and Helvetica.



## Slab serif

### Slab serif

Strong, solid and sturdy.  
Used when legibility rather than beauty is required.  
Common slab serifs include typewriter fonts.  
Sometimes known as 'Egyptian' typefaces.

Originating in the early 19th century, slab or block serif was used on promotional posters, theatrical flyers, brochures and billboard advertising. Slab serif typefaces have a geometric serif detail and can appear to be striking and solid in appearance. Traditional typewriter typefaces used a slab serif type. Examples still in use today are Courier and Rockwell.

## Decorative

### Decorative

Use with care and consideration.  
Can be eye-catching and have visual impact.  
Best used for titles and not body text.

Decorative typefaces are often used to create visual interest and they can add humour to a composition, but they are not suitable for blocks of text. Often used in promotional advertising material, decorative type might reinforce the meaning of the type with visual elements. For example, 'Red Hot Sale' on a brochure might include flame or a melting typeface. Decorative type can grab attention or, in the case of traditional illuminated manuscripts, add beauty to a document, but should be used conservatively. Decorative typefaces are sometimes known as 'graphic' typefaces.

## Script

### Script

*Traditional, elegant and refined.  
Use for headings, contrast and special emphasis.  
Not suitable for large areas of text.*

Developed from handwriting and maintaining the visual connections or 'flow' between individual letters, script typefaces imitate traditional pen handwriting. Script typefaces such as Edwardian or Engravers Script are often used to create a sense of history or tradition within a composition.

## Handwritten

### Handwritten

*Highly contemporary, edgy and individual.  
Best used for short paragraphs or titles.  
Not suitable for large areas of body text.*

A popular type style used in contemporary design is handwriting. The development of less structured typefaces that contain characteristics reminiscent of handwriting is commonly associated with the [maker movement](#) and the rise of the 'artisan-designer'. Like decorative type, these should only be used in an appropriate context but can add a highly contemporary edge to compositions.

## Calligraphic

### Calligraphic

*Contemporary interpretations of traditional calligraphy using flourishes and swashes for emphasis. Best used for titles, identity and signage. Not suitable as body text due to legibility issues.*

Contemporary calligraphic typefaces are typical of the maker movement and reference the script's type style. Created using traditional calligraphy, brush and pen techniques, calligraphic or 'brush' typefaces are regularly used for posters, web designs, type-based prints and artworks, identity design and signage.

Type can be:

- + contemporary
- + dominant
- + serif
- + sans serif
- + block serif
- + plain
- + decorative
- + script.

Type can vary in:

- + point size
- + font
- + typeface
- + readability.

Type can be used to:

- + identify important information
- + create a hierarchy
- + create contrast
- + create an emotive response
- + create a logo.

See Chapter 6 for detailed information on type.

## DESIGN PRINCIPLES

If design elements are the construction materials, then **design principles** are the method of construction. The arrangement of design elements in a composition is defined and directed by the application of design principles.

There are eight design principles: balance, contrast, cropping, hierarchy, figure-ground, pattern, proportion and scale.

### BALANCE

Think of a child's playground. Remember the seesaw? Did you ever try to use the seesaw on your own? Well, that wasn't much fun, was it? But find a friend to sit on the other end and suddenly it becomes much more interesting. Although balancing the seesaw evenly was fun, the real thrill was in the way an uneven distribution of weight made the seesaw tip up and down.

Like the seesaw, when **balance** is applied effectively to a composition the result is much

more successful. Visual communications can be stable and even – or uneven and thrilling! Balance in visual communications establishes harmony in a composition, and harmony creates visual appeal. Whether we realise it or not we like to see balanced compositions. It has been suggested that the appeal of balance reflects the equilibrium of the human body. Visual communications that are unbalanced can lack emphasis and visual appeal and may ultimately discourage us from looking, using or consuming.

In establishing harmony, balance helps to create successful a visual communication, but don't be fooled into thinking that harmonious design means quiet, dull and boring – quite the contrary!

Balance can be symmetrical or asymmetrical, and each style has appropriate applications. The purpose, audience and context of your visual communication will define which style to use.

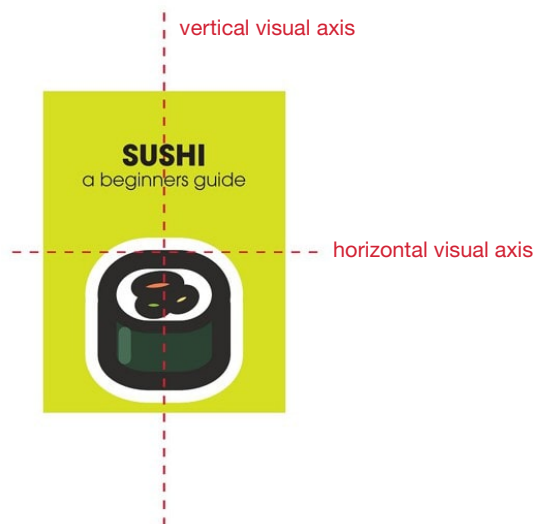

Imagine a composition that has been divided through the centre by an invisible horizontal line (**axis**) and an invisible vertical line. Both axes provide reference points for creating balanced and visually harmonious compositions. Although we cannot see the axes, they provide a structure that can be used to assist in planning an effective design.

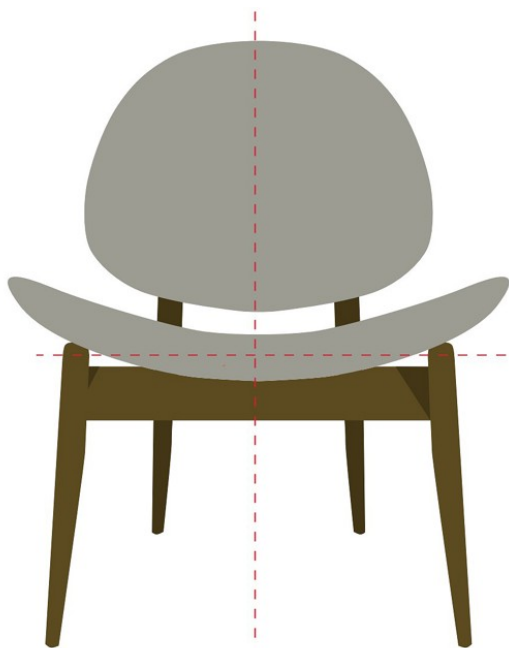

▲ Balance in reference to a vertical and horizontal axis is equally applicable to three-dimensional design.

### Symmetrical balance

A composition with symmetrical balance mirrors the elements on opposite sides of the visual axis – from one side to the other.

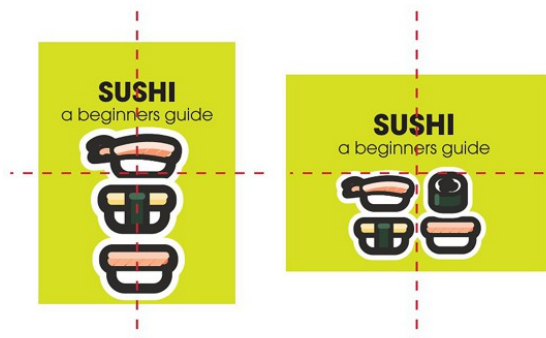

▲ Symmetrical balance

Symmetrical composition is seen to be stable, static and passive. Such composition has a sense of regularity or conformity, which makes it suitable for a purpose that requires such characteristics. Symmetrical balance can be perceived as formal and organised in style, but it can also achieve a sense of unity between design elements, creating order and even a sense of beauty.

### THE FACE

FYI

Recent studies confirm what artists have for centuries believed – that our perception of beauty in the human face is based almost entirely on **symmetry**. The more symmetrical a person’s facial features, the more likely they are to be perceived as beautiful. Very few faces are perfectly symmetrical.

When approaching a symmetrical composition, it is possible to over-emphasise the centre and align elements in a restricted manner. It is important to be aware of the entire space you are working with.

The placement of elements in relation to an axis leads the viewer’s eye into the composition. Creating a harmonious balance means that left-to-right balance and top-to-bottom balance are equally important in order to keep the viewer focused on the composition.

Many images appear more stable if the bottom seems slightly heavier. If the top appears too heavy, the composition may look unstable.

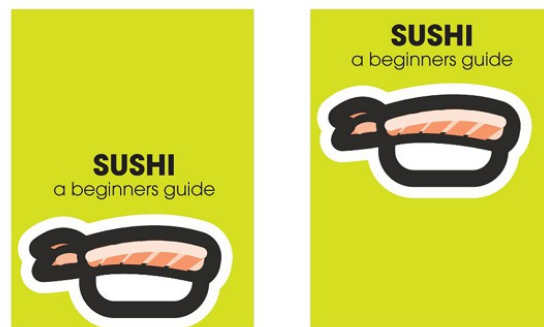

Sometimes our own sense of balance is refined enough to sense when the balance in a composition is wrong. With practice you will recognise when a composition is balanced and when it is not.

## Asymmetrical balance

Based around a central visual axis, asymmetrical balance is characterised by an arrangement of elements that is not mirrored or equal in appearance. Asymmetrically balanced compositions appear to be more dynamic than symmetrical compositions because the placement of elements creates a sense of dynamic energy.

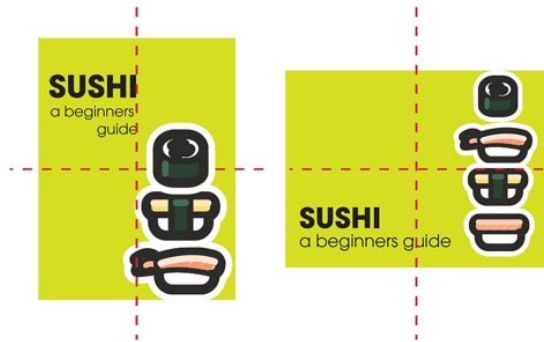

▲ Asymmetrical balance

The important thing to remember with asymmetrical balance is that the composition is still balanced! Balance is created by manipulating elements and does not have to fit the traditional 'left, right and centre' **alignment** approach. Asymmetrically balanced compositions can be created by the repetition of elements and images, and the creative use of scale, cropping and type.

It is even possible to use what appears to be nothing at all! The use of **white space** or areas that do not contain important visual details can lead to eye-catching results.

Asymmetry is often found in two-dimensional and three-dimensional designs that challenge, provoke and inspire us. Experimental designs challenge our perceptions of balance and harmony, stimulate debate and discussion, and force us to reassess our values and comfort zone.

## Using white space: 'Less is more'

Attributed to Bauhaus designer Ludwig Mies van der Rohe, this statement defines much of the philosophy of the influential design movement of the 1930s. The Bauhaus rejected the decorative details and motifs seen in previous design movements. Their preference for the minimal influenced generations of designers who believed that what is left out of a composition can sometimes be as powerful as what is placed in it.

Which brings us to white space.



▲ Balance can be created with 'white' or empty space.

A cluttered composition can be distracting and difficult to understand. It can be important to include detailed information in a composition but it is also important to recognise that too much information can make a viewer quickly lose interest.

White space does not necessarily mean blank white space – it may contain a colour or pattern – but it will lead the viewer's eye to the crucial information. White

space can be used effectively to balance a composition. For instance, a large area of white space may balance an equally large area of text, as it will be equal in visual ‘weight’.

With practice, it is possible to use areas of white space in symmetrical and asymmetrical compositions to create striking and memorable visual communications.

## CONTRAST

Sometimes, conflict is a good thing!

**Contrast** is created when two very different elements are used together for visual effect. Contrast can create conflict between elements – light versus dark, bold versus fine – which leads to a visually dramatic composition.

Contrast creates a tension between elements. In fiction and film, tension heightens the interest of the reader or viewer – an increased level of tension encourages a sense of anticipation by raising the heart rate and stirring further interest in the storyline. Although visual contrast may not always make the heart race faster, it attracts attention and encourages



Stockphoto/jpa1999

▲ The use of bold contrasts conveys a sense of drama and menace.

interest in the content of the composition. Contrast, used bravely, stimulates interest in a composition that might otherwise go unnoticed.

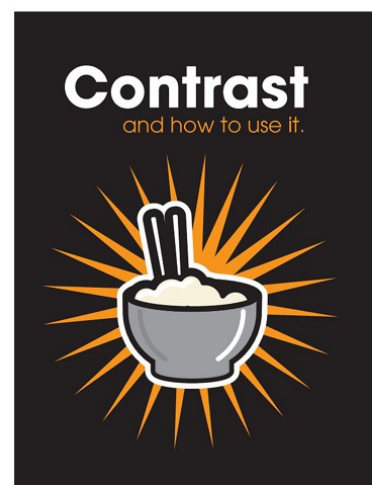
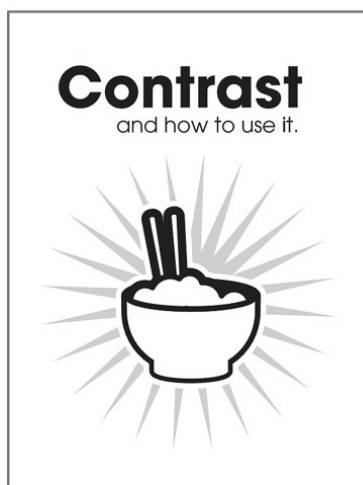

▲ Notice how the appearance of this composition becomes immediately more striking when contrasting elements are added.

Contrast is created in many different ways and with many different elements. The key to effective use of contrast is to use it boldly. Don't be afraid to take risks with contrasting elements.

## Contrast in type

Bold, sans serif type and script are vastly different in style but are sometimes seen together to contrast two words. A less dramatic version is the use of a bold typeface and a regular typeface from the same typographic family. Contrast is sometimes used at the beginning of a chapter in a book. You may see the title letter in a bolder and larger scale font than is used in the body of the text; this is called a drop cap and establishes the beginning of a chapter or section.

Iveco Latin America, reproduced with permission



- ▲ An elephant and a truck are, ordinarily, unrelated elements, but in this vehicle advertisement, the juxtaposition of the two objects serves to emphasise the strength and load capacity of the vehicle.

## JUXTAPOSITION

Juxtaposition refers to the placement of two different elements together within a composition in a **proximity** that suggests a comparison. Otherwise unrelated elements are contrasted to create a strong visual relationship that communicates a message.

FYI

**L**orem ipsum dolor sit amet, consectetur adipiscing elit. Maecenas imperdiet orci vel dolor consectetur vitae aliquet ipsum sodales. Nam venenatis libero at metus tristique in lacinia est rutrum. Phasellus feugiat auctor felis quis bibendum. Cras congue lacus ac ligula accumsan imperdiet. Pellentesque habitant morbi tristique senectus et netus et malesuada fames ac turpis egestas. In blandit, est vel viverra pretium, eros lacus ornare leo, at blandit ligula felis laoreet ligula.

- ▲ The use of a drop cap in a contrasting script typeface clearly defines the beginning of this section of body text.

## Create contrast within the same type family

(Helvetica Neue LT Bold and Light)

## CREATE CONTRAST using upper and lower case

(Futura Medium)

## CREATE CONTRAST using different type styles

(Univers and Bookman Old Style)

- ▲ Using only one or two typefaces, a designer can easily create contrast using type. Typeface families are designed to work together but also offer opportunities for contrast.

## Contrast in colour

Contrast can cause colours to virtually move around on a page, creating dazzling and dramatic effects. Some combinations of colour can create a discordant result, which may be uncomfortable to view. (Deep blue and deep red combined can have this unpleasant effect on the viewer.) However, as the human eye responds quickly to colourful stimulus, contrast using the element of colour can be a powerful tool. Colours that sit opposite one another on the colour wheel generate the greatest amount of contrast. Contrast can be generated through the application of cool and warm colours, or by one colour used at significantly different levels of intensity.



- ▲ The use of contrasting colour emphasises the seasonal nature of these greetings. The clever use of contrast creates the metaphorical Christmas tree in both images.

The use of contrasting colours can create optical effects. As mentioned, blue and red used at equal intensity can seem to ‘fight’ for the most dominant role in a composition, creating the illusion of movement.

## Contrast in tone and texture

Contrasting tones can assist in defining the form of objects in rendering. The difference between a dark tone and a very light or white highlight creates a sense of an object in space. Tone provides information about the surface of a form that, without contrast, would appear flat.

### TIP: CONTRASTING TONES

When applying tone to an object, it is important to use a wide range of tones and to be comfortable about applying black and using white. Use the paper itself as the lightest highlight and use a 6B or even softer pencil to create very dark shadows.



Contrast can be used for dramatic effect when combining textures. In fashion and textile design, it is possible to see clear plastics and soft fabrics incorporated together in some contemporary clothing and accessories. Clashing colours and contrasting fabrics are often used to draw attention to part of a garment.

## Contrast in line

Bold line, fine line, broken line, solid line ...

Variations in line thickness provide subtle but effective contrasts. Segments of a text-heavy document can be separated with lines, or a heading

can be underlined by a bold line. In rendering form, line is often used as a single element or as part of a crosshatched pattern. Lines placed close together can create a dark tone – and when spaced further apart, can appear lighter. A rendered line can contrast with areas that contain no rendering at all to create a greater sense of form.

## Contrast in point, shape and form

Contrasting shapes such as a square and a circle can be used as part of an alternating pattern to create visual interest. A pattern that contains variation and particularly strong contrasts is immediately more dominant and noticeable than a pattern that does not. Point can also be used in this way to create noticeable visual variations.

Shape is used to contrast with other elements. Organic shapes can soften strong colours, and geometric shapes can provide a contrasting ground for text and the placement of images.



AAP Image/Julian Smith

- ▲ Storey Hall, RMIT University. In architectural design, the contrast between forms and materials, textures and colours can create striking and provocative structures.

Geometric forms can be used with organic abstract forms to create contrast in interior and exterior architecture. In the design of residential and commercial buildings, architects often work with landscape designers to create contrast between the natural and constructed environment; for example, the contrast between a gently sloping garden and the geometric lines of a contemporary home can create a dramatic effect.

## CROPPING

Where contrast creates tension, **cropping** adds intrigue to a composition. Cropping is the exclusion of parts of an element for greater visual effect. Cropping is a powerful design principle.

It is possible to create emphasis by placing an element 'outside' the perceived boundaries of a composition. Suddenly, the appearance of the composition becomes more interesting, more intriguing. The eye is drawn into the composition, and subconscious questions may be posed, such as: Where does it lead? Where does it come from? Although we may not be aware of it, cropping suggests visual possibilities that our imagination may choose to follow.



- ▲ The second image above has been cropped effectively. The original object is still recognisable and the image has strong visual impact.

As with all design principles, there is a good and bad way to introduce cropping into a composition. **Think before you crop!**

Ask yourself: What am I trying to emphasise? Does the element need to remain recognisable or can it become an abstract inclusion? This will determine the extent to which you crop the element you are working with. It is important not to compromise the image or type that you have cropped by removing too much visual information.



- ▲ The image on the right has been cropped too dramatically and has become unrecognisable as the original object.

Cropping can be applied to the figure or ground of a composition. Type, shape and form can be altered in scale – or in proportion to other elements – and then cropped to achieve dramatic effects. Both two-dimensional and three-dimensional presentations benefit from the application of cropping.



- ▲ Movie posters often use cropping as a graphic device to attract the audience. The use of cropping suggests that there is more to the story, develops a sense of intrigue and, ideally, creates considerable visual interest.



Modelled three-dimensional digital work gains realism when cropped within a frame. Visually striking photographs are often cropped creatively to emphasise a subject or theme. Remember that a composition does not have to begin and end with the edge of a page or the computer screen!

## HIERARCHY

As we grow up, we become familiar with the concept of **hierarchy**. If you are a youngest child and were forced to sit in the middle seat in the car, or were the last person to have your opinion heard, you may have been painfully aware of family hierarchy. Hierarchy is the establishment of an order of importance. Just like a 'pecking order' within a family, there is a hierarchy within a composition.



In producing a composition, it is essential to understand the purpose for which it will be used. This will influence the arrangement of the most important elements. In learning about hierarchy, the front page of a newspaper is a great place to start. Every day, the newspaper will feature a masthead, main headline,

subheadings, photographs and text. We quickly recognise that the headline is the most dominant element – the type is usually bold and much larger than the subheadings or body of text. Hierarchy, in this case, is established through scale. The second element in the hierarchy may be the photograph, followed by (or equal to) the masthead, the text and other material.



▲ No established visual harmony



▲ Hierarchy established through scale



▲ *Made* magazine makes clever use of hierarchy. A dominant image leads the viewer directly to the eyes of the dog, quickly moving to the name of the magazine *MADE*. 'Edition Three' is printed in a contrasting silver foil, which draws the eye down, while again, the vivid eyes of the dog draw the eye back to the title.

**TIP: THE EYE HAS IT!**

When attempting to understand the hierarchy of a composition, close your eyes for a few seconds. When you open them, what is your eye first drawn to? The dominant element will establish the hierarchy.

Hierarchy can be established in many ways. The use of scale, as shown above, is only one method. Dominant colours, shapes and textures can also draw the eye to the most important aspects of a composition. Poor use of hierarchy, however, can distract from the message of a visual communication, so it is essential to control the dominance of elements in a composition.

**FIGURE-GROUND**

**Figure-ground** – sometimes known as negative-positive space, form-counterform or foreground-background – is used in the Visual Communication Design course to describe the relationship between dominant and less dominant elements within a composition.

**GESTALT THEORY**

**FYI**

During the 1920s a group of German psychologists developed theories of visual perception based on how the human eye groups visual elements into a whole. 'Gestalt' is translated as 'whole' and reflects the theory that, when images are arranged in a certain way, our brain groups them together into a cohesive concept. The Gestalt principles most commonly applied in design are: Figure-ground Proximity, Similarity, Continuation, and Closure. The application of Gestalt theory is important when creating designs that are coherent and visually effective.

'Figure' refers to the visual information that is most dominant when placed against the ground. (It includes all the most dominant material rather than a single piece of visual information.) The 'ground' is usually the visual material placed in the background or, in some cases, the white space that surrounds the figure.

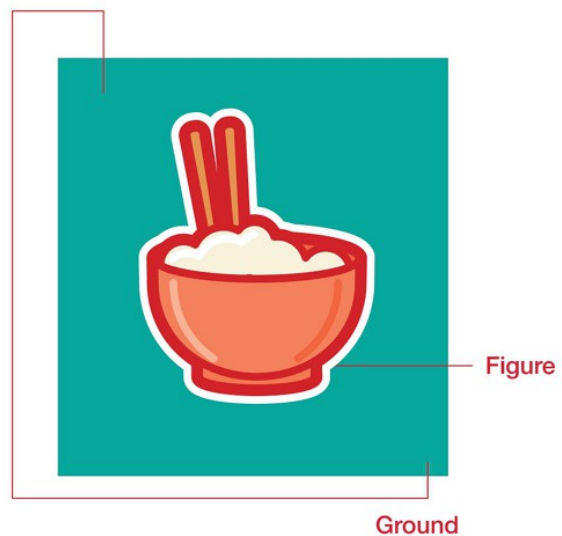

In most instances, the figure is the most important visual element, and the ground is used as support. The dominance of the figure is established by the application of elements and principles that identify it

as having an important position in the compositional hierarchy. A dominant figure may be large in size, bold in colour, cropped dramatically or feature detailed tonal variations – there are many methods of establishing the figure as the focus.

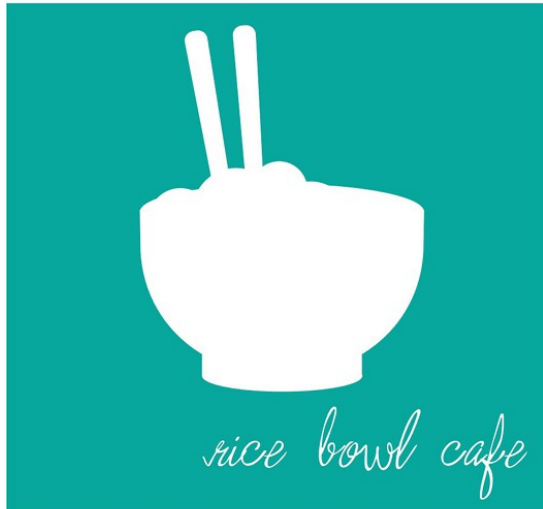

▲ The ground defines the figure.

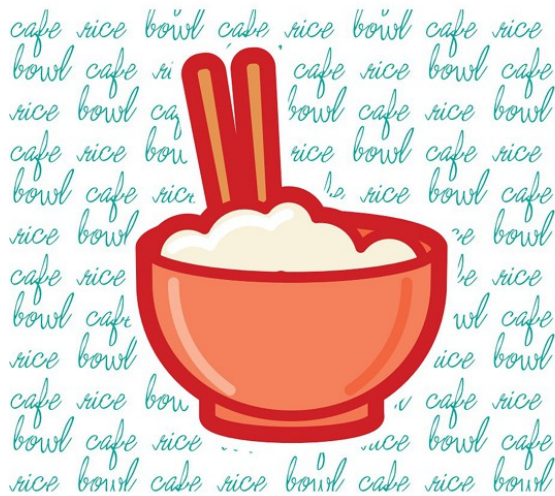

▲ The ground enhances the appearance or meaning of the figure.

The ground often contains images, type and other elements that reinforce the theme or message of the figure. The ground can be used as an influential visual tool, as its content may emphasise the figure itself. At times quite subtle, the ground may feature images

that enhance the appeal of the figure. For instance, in automotive advertising, the ground may be used to feature a slightly blurred landscape, designed to suggest speed and handling – appealing characteristics immediately associated with the figure, which is the car itself.



▲ In this logo design for Citrus Splash Candles, the ground creates the segments of the orange and the flame of the candle, while the figure represents the source of the product.



Alamy Stock Photo/Photo 12

▲ Figure-ground is used effectively in this movie poster. The main figure is linked to the secondary element contained within the ground, establishing what seems to be an important visual relationship. The ground is also used in the typography with the creation of a large counter-area.



▲ A simple design for a DL-sized flyer uses a combination of colour and figure-ground to emphasise the service.

## PATTERN

**Pattern** refers to the repetition of elements within a composition. Pattern tends to be organised, and it features elements that are repeated more than once. When used as a tool for visual organisation, patterns can vary from the most basic application of lines and shapes to complex patterns inspired by natural, irregular forms.

### Repetitive pattern

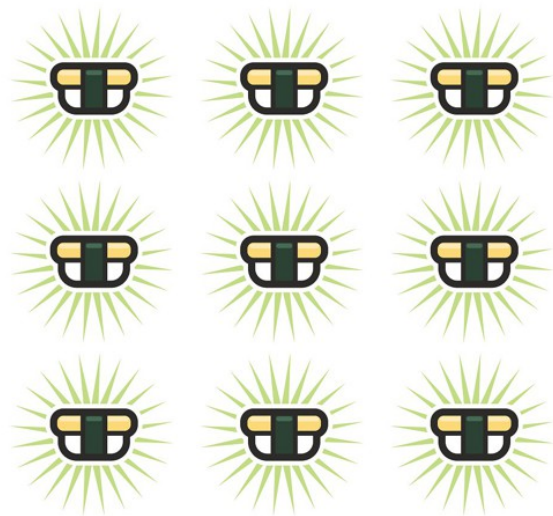

Patterns that use elements over and over are repetitive. They may be simple arrangements of lines, shapes or images, but their common characteristic is that they repeat the same sequence of imagery.

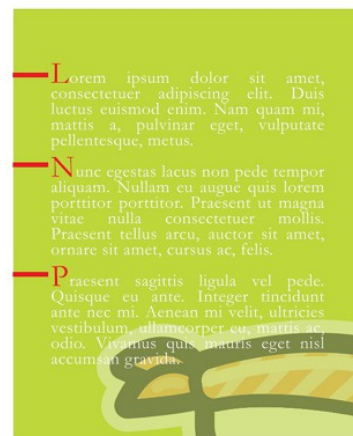
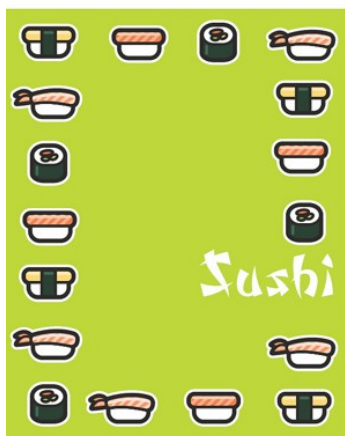

▲ Pattern can be used in many different ways: in borders, to distinguish lists of information and as a visual device.

Repetitive patterns create a sense of unity and establish clear relationships within a composition. The power of repetitive patterns lies in their consistency. The repetition of elements may be as basic as a bulleted list in a document, or as complex as the structure of enlarged snowflakes or a Byzantine tile mosaic.

Repetitive patterns can create a sense of rhythm in a composition, adding movement to the elements. Repeating an arrangement of shapes in a manner that is dynamic adds energy and visual interest. Creative use of figure-ground can allow for the construction of patterns that are visually ambiguous and optically intriguing.

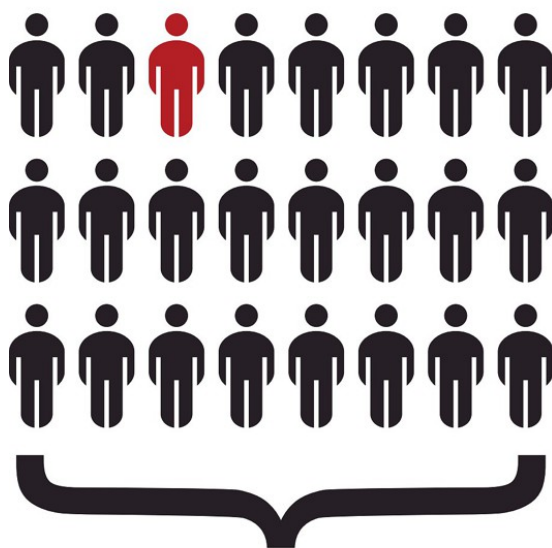

RATE OF INFECTION  
BY POPULATION

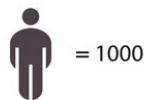

- ▲ In this extract from an 'infographic' or 'statistical diagram', pattern has been used to convey a numeric value. The repetition of elements can assist the viewer to visualise a complex concept such as quantity.

## Alternating pattern



Patterns that alternate may consist of several different elements used in a changing sequence. Alternating patterns can be created using any visual element and can add visual variety and dynamism to a composition.

Textile designers commonly use alternating patterns that display variations in colour, line and shape. Although designers who work with fabric and textiles may focus on the purpose of the material – such as its application to an individual item of clothing or a handbag – they also have a keen sense of how pattern will appear on a larger scale.

Like repetitive pattern, alternating pattern creates a sense of order, but in a very different way. The variation of a pattern that alternates a range of elements conveys innate energy and life.



- ▲ A range of patterns are used in this visual communication. The colourful background, bunting and repeated icons combine to suggest a vibrant and appealing event. Multiple patterns, in the right context, can add life to an image.



iStockphoto/Jarek Szymanski



iStockphoto/millsrymer



iStockphoto/Silvia Boratti

▲ Pattern occurs in nature and the constructed environment.

Many patterns occur in nature and in the constructed environment. These can be a great source of inspiration in design and may trigger ideas for two-dimensional and three-dimensional design concepts.

Pattern is used in many areas of design. Digital designers use repeating patterns to create wallpapers and backgrounds for computer-operating systems and webpages.

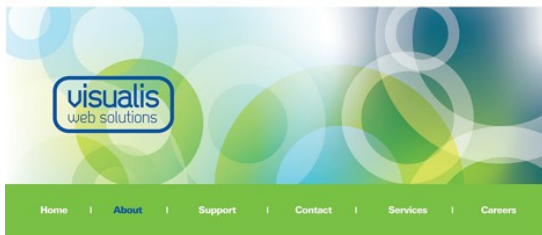

▲ Digital patterns for Web and print design are known as 'seamless' patterns. They are made of one image that can be repeated over and over. They are used commonly in Web content as backgrounds or wallpapers.

Textile and interior designers use patterns in fabrics and surface decoration. Patterns may alter as fashions and trends change but they are integral to many areas of design. Pattern designers may use traditional techniques and materials in the creation of pattern such as screen-printing, drawing and dyeing. However, in fashion, many commercial fabrics have their patterns developed and refined entirely by computer.



▲ When designing repeating patterns, ensure there is a link between elements on opposite sides of the original image to create a seamless pattern. The image can then be repeated like a set of tiles.

**TIP: PATTERN**

Adobe product screenshot reprinted with permission from Adobe Systems Incorporated.

In vector programs such as Adobe Illustrator, it is possible to use existing patterns or to create 'swatches' of your own design that can then be tiled into seamless patterns. Just remember to make sure that there is a link between elements so that joins cannot be seen.

## PROPORTION

**Proportion** in visual communications is about relationships – relationships between the scale of parts of an object or a composition. Proportion, properly used, creates balance and in turn provides visual harmony – an essential in the creation of pleasing visual communications.

How do objects relate to one another within a composition? A chair that has a small seat and an oversized back support may be uncomfortable and ugly. That doesn't mean that an overly large back support is not a feasible design option; its elements simply need to



▲ Note the proportional differences between the two images of the teacup and saucer.

be in proportion to one another to become an effective design. Likewise, in two-dimensional design, proportion is essential to creating successful designs.

In the above image, the proportions of shape and line are incorrect. This interferes with the believability and the attractiveness of the illustration. If the viewer becomes distracted by inconsistencies such as poor proportion it is likely that they will miss the message of the visual communication.

**AESTHETIC PERFECTION** FYI

During the Renaissance, artists were concerned with the pursuit of visual harmony and beauty in drawing, painting and architecture. This pursuit of aesthetic perfection led to the development of complex geometric systems of proportion. Artists and architects used systems such as the 'golden ratio', 'golden section' or 'divine proportion' devised by the ancient Greeks, which defined a clear visual order as a geometric equation.

Similarly, the 'harmonic ratios' of the Renaissance established a visual balance in objects by establishing that the proportions within the form matched the overall proportion of the form as a whole.

**LINK: GOLDEN RATIO** 🔍

This online tool allows the user to calculate the golden ratio of a series of measurements; a handy tool when creating layouts for Web and print pages. You can link directly to the website via <http://vcd.nelsonnet.com.au>

Proportion relates to the comparison of different elements within a composition. Relationships are important in any composition; they indicate which elements relate to one another and lead the eye through information in the most effective manner.

We are naturally attuned to proportion, and intuitively understand when something is 'out of



Bundoora Park, City of Darebin

- ▲ Although the eucalyptus leaf is clearly out of proportion to the bird in this logo, we accept the proportional difference because it works as a creative linking device and a pleasing composition.

proportion'. Particularly important in observational drawing, proportion helps us to depict realistic representations of objects. Renaissance artists such as Leonardo da Vinci researched the 'ideal' proportions of the human body, and da Vinci, among others, established a scale to guide artists in the depiction of the idealised classical male figure.

Much later, in the 1940s, French artist and architect Le Corbusier established a scale of proportion between the human body and architectural design called the 'Modulor system'.

'Playing' with proportions can lead to innovative and creative design solutions, so don't be afraid to experiment in your own work. Cartoonists commonly use exaggerated differences in scale and proportion to draw attention to a humorous concept.

When drawing from direct observation, it is essential to establish the relative proportions of physical details in order to produce the most authentic representation.

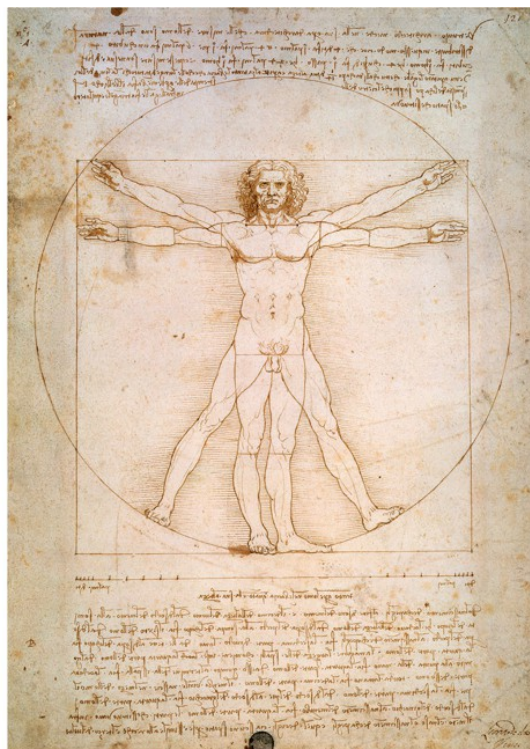

Getty Images/Garry Gay

- ▲ Leonardo da Vinci created this drawing of average human (male) proportions based on the writings of the ancient Roman architect Vitruvius.



iStockphoto/Magdalena Tworkowska

- ▲ Exaggerated proportions are used in caricature and cartoons.



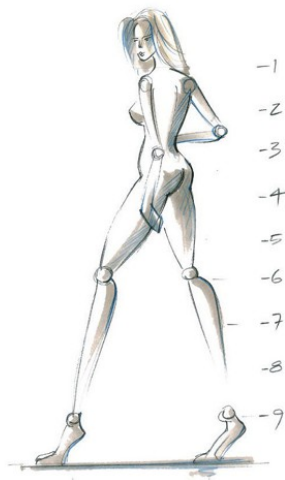

▲ Fashion illustrators distort the proportions of the human figure to emphasise features such as legs and necks. Generally speaking, the human body is equal to the height of 7.5 to 8 heads. In fashion illustration, those proportions are extended to nine heads, which creates a lengthened legs and torso.

## SCALE

Scale concerns the size of elements within a composition. Scale exists because of relationships between different elements in a hierarchy. Scale, which we can also refer to as size, assists the viewer to make sense of depth, distance and proportions in a composition. Scale enables us to make comparisons between elements or objects, and helps to add meaning. A statistical diagram, for example, uses differences in scale to depict differences in the data.

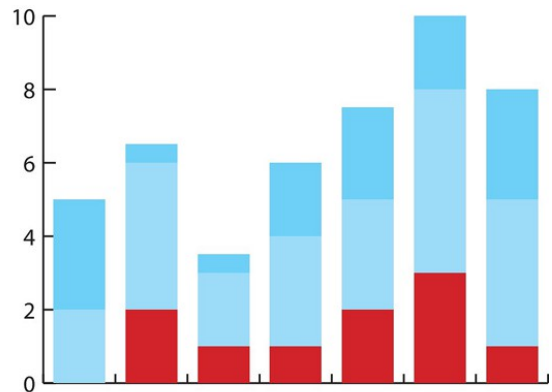
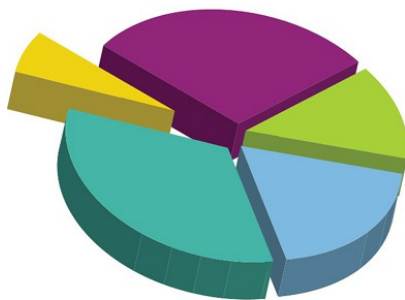

Scale is used to add realism to an illustration. The placement of familiar images such as the human body can provide a context in which to depict a product or construction. Architectural illustrations often use trees, foliage, cars and figures to suggest the realistic scale of a construction.



Scale can be exaggerated and used to create dynamic contrasts in visual communications. Using elements that play with our innate sense of scale can reinforce the meaning or theme of a composition. Scale and proportion often work together for visual impact. Adjustments to scale can often affect proportions in an illustration, construction or composition.

Through our understanding of instrumental drawings such as orthogonal drawing, scale is a familiar tool. Scale is used to illustrate details that cannot be represented at their actual size. Scale is applied to complex information such as maps to assist our comprehension of large amounts of information.

Scale models are used in many areas of three-dimensional design to evaluate a concept. The opportunity to observe a design concept in



Prue Edmunds

▲ Scale model of a dwelling.

three-dimensional form is valuable, as the strengths and weaknesses of the concept are more clearly identifiable. A model enables a client or other interested party to view a realistic representation of a product that may otherwise be difficult to visualise from a two-dimensional form. Scale models are used in many areas of design, such as automotive design, architecture, design of theatre sets and product design.

The identification of scale can be used in illustration and layout to highlight important visual information.

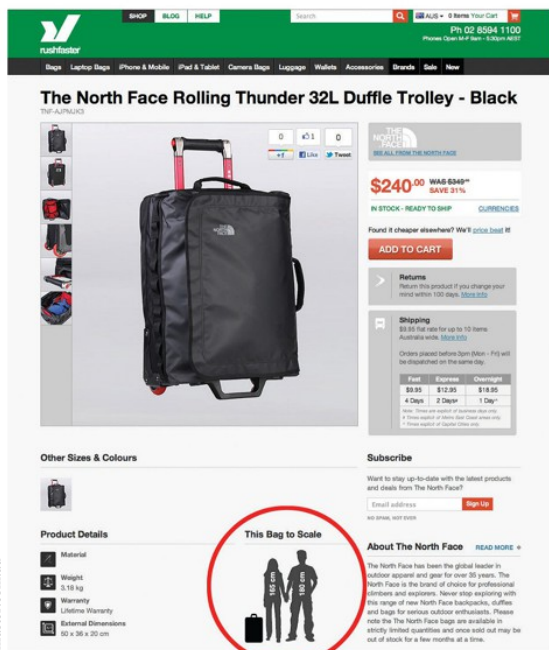

Rushfaster.com.au

▲ Rushfaster sell bags and luggage online. To assist purchasers with decision making, a scale is used to help visualise the size of each bag.

## CHAPTER RECAP



- 1 Explain the meaning of the following terms and phrases:
  - + analogous colour
  - + symmetrical balance
  - + repetitive pattern
  - + figure-ground relationship
  - + dominant hierarchy
  - + unproportioned
  - + modular system
  - + dramatic contrast
  - + white space
  - + geometric form.
- 2 a Develop a glossary of descriptive words for each of the design elements. Use the suggestions in this chapter to start your list and add as many additional words as you can.
  - b In your own words, create a minimum of eight sentences that describe the effect of each design principle. For example: 'Repetitive **pattern** can help to reinforce a visual motif or theme'. Try to build up as many sentences as you can for each principle. Share with others in your class to create a helpful collection to assist with analysis and annotation.
- 3 Suggest how at least one design element and one design principle might be applied within the following design scenarios.
  - a A poster to promote the opening of a new Early Learning Centre for 3 to 4 year olds.
  - b The design for the interior of a bookshop and cafe in a regional hospital.
  - c A scale model of a sustainable 'tiny house'.
  - d Wayfinding system at a water park.
  - e The cover design for the program of an acrobat-based circus.



# TYPOGRAPHY AND LAYOUT

CHAPTER

6

## In this chapter:

+ Typography .....	115
» Typographic language .....	115
» Type classification .....	119
» Legibility.....	120
+ History of typography .....	124
» Early books .....	124
» Gutenberg and the printing press .....	124
» Early typefaces.....	125
» Developments in the 18th and 19th centuries.....	125
» Twentieth-century modernism.....	126
» Digital design .....	127
» Handwritten type.....	127
+ Layout.....	129
» Grid .....	129
» Alignment.....	132

## Learn the language

+ Typography			
baseline	leading	style	typeface
Kerning	spacing	tracking	x-height
+ Layout			
alignment	composition	gutter	marker
column	grid	margin	module

You will find helpful tasks related to typography and layout in Chapter 9 and throughout *Nelson Visual Communication Design VCE Units 1–4 Workbook, Edition Three*.

# TYPOGRAPHY

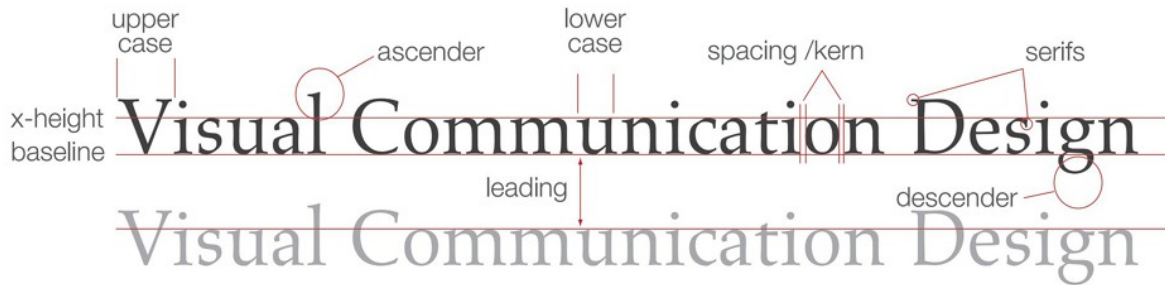

## TYPOGRAPHIC LANGUAGE

More so than any other design element, typography requires its own language. Terms that have their origin in the history of type design are still used today. In this section we will look at the key terminology that has evolved over time to explain the many elements of typography.

Some knowledge of the language of typography is essential when discussing any aspect of this design form.

### Ampersand

An ampersand is a ligature (see page 117) of the Latin 'et' (meaning 'and'). The appearance of an ampersand can often identify the **typeface** in use.



### Ascender

The part of a glyph or letterform that sits above the **x-height**.

### Baseline

The **baseline** is the imaginary line that a typeface sits upon. Some letters, such as the O in certain typefaces, may sit slightly below the baseline. When a designer needs to adjust the position of letterforms above or below the baseline, they create what is known as a 'baseline shift'.

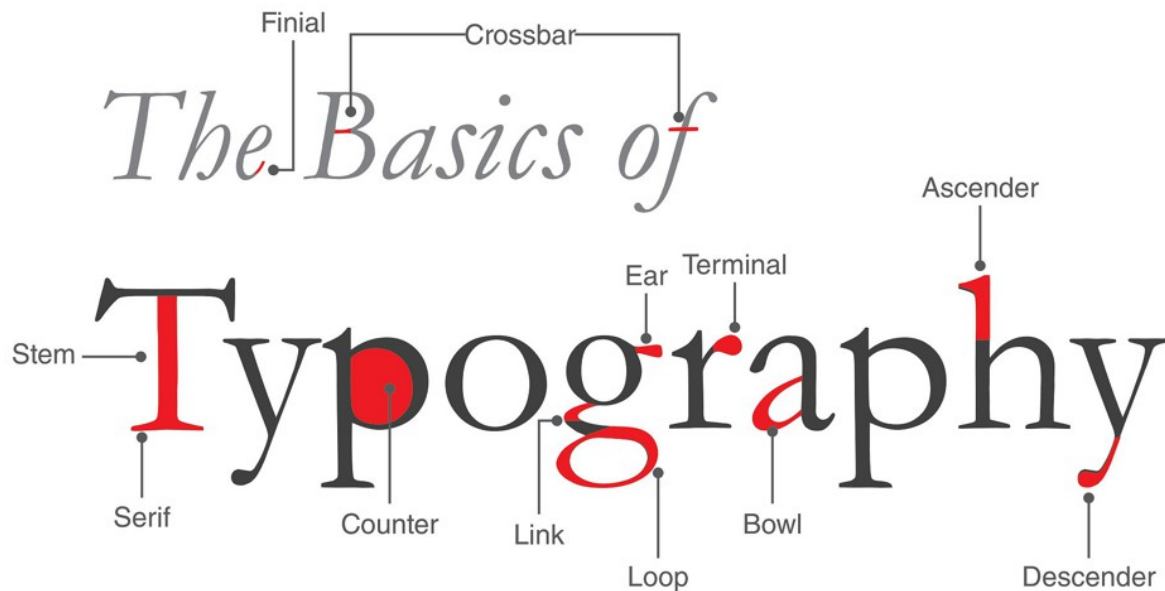

## Body text

Body text refers to the main areas of text in a document. Body text may also be called a text block. The selection of a typeface for body text is crucial and entirely defined by the context of the design. For example, newspapers and magazines often use **serif** type for body text as it is considered to be easier to read.

## Bowl

The part of a type character that encloses (or partially encloses) a rounded space, for example a lower-case a or upper-case G.

## Case

Upper (majuscule) and lower (minuscule) case letters are named as such because printers using metal type kept them in the upper and lower type boxes or cases. Upper-case letters are less legible when used in body text. Combinations of upper- and lower-case letters are often known as sentence case.

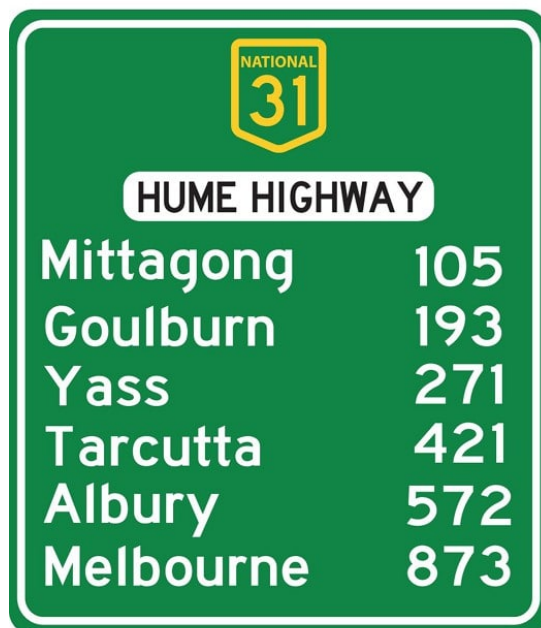

- ▲ Upper- and lower-case letters are used on directional Australian road signage. The combination of letterforms is easily recognisable at speed. The typeface used in Australia is called Highway Gothic.

## Counter

The counter (sometimes referred to as the counterspace or counterform) is the negative space in and around the letterform. Counters are seen on lower-case a, b, d, e, g, o, p and q characters, and in most of their upper-case versions as well. The counter can be used creatively to enhance the meaning of a letterform or word.



## Descender

This is the part of a glyph or letterform that falls below the baseline.

## Ear

The distinctive element that rests on the upper right of the lower-case g. 'Ear' is the root of the word 'earmark', a term for the distinctive visual features that identify different type families.

## Face

The term 'face' is interchangeable with the term 'typeface'.

## Family

A type family is made up of all the widths, sizes and **styles** of a typeface. Helvetica, for example, includes Roman, Medium, Italic, Light, Condensed, Extended, Bold and Heavy in its family. Although it is possible to make many typefaces bold or italic by electronic means on the computer, using the italic or bold version from the font family reduces the risk of this 'dropping out' during the printing process.

## Font

Originally, the term font was used to describe a type family of one size only; for example, Times New Roman 10 pt (see 'Type size' on page 119). Since the advent of digital design, font has become interchangeable with the terms typeface and type family.

## Grotesque/Grotesk

In the 19th century **sans serif** type was commonly known as Grotesque, lineal or Gothic type. These days sans serif is the term more widely used but many typeface names still include reference to Grotesque/Grotesk or Gothic.

## Italic

An italic type is not mechanically slanted (that is, forced to be italicised by selecting 'I' in your word processing program); rather, it is a separate version of a typeface that has been specifically designed on a slanted angle. Aldus Manutius and Francesco Griffo designed the first italic font in Venice in 1501.

## Kerning

**Kerning** refers to the space between individual letterforms. Some letterforms need to have the space adjusted when they are used together, for example a T and L used together have larger **spacing** than an M and E. The type designer kerns most commercial typefaces but design software programs allow some adjustment to kerning to improve visual appearance if required.

## Leading

**Leading** (pronounced *ledding*) is the distance between two lines of type. The term is derived from

Leading is the space between lines of type.  
Leading affects the legibility of text.

Type without leading or with leading that is too close can interfere with the legibility of the text.

16 pt Myriad Pro with 12 pt leading

As can leading that is too far apart as the flow of the

text may be too difficult for the reader to follow.

16 pt Myriad Pro with 44 pt leading

Most auto leading in computer software is set 1–2 points above the point size  
 For example, this sentence is set in 16 point type with 18 point leading.

the strips of lead that were placed between lines of type in traditional typesetting. Leading directly affects the legibility of type and is usually set so that the eye flows easily from one line to the next. Leading is often set automatically in computer software but can be manipulated depending on the context.

## Letterform

Letterform refers to individual type forms including symbols, numerals and icons.

## Ligature

A ligature is formed by two or more letters being joined by a stroke or bar to produce one character, such as f and I or f and t. Ligatures originate from common letter combinations in Latin. They are often seen in script typefaces and in Scandinavian languages. When used in English, they are used to increase **legibility**.



Wikimedia Commons/Daniel Ullrich, Threectors.

▲ Example of a ligature.

### Lining and non-lining numerals

Numerals can be identified as upper case and lower case. Lining, or upper-case numerals, adhere to the baseline. Non-lining, or lower-case numerals, feature descenders that drop below the baseline. Not all typeface families carry both lining and non-lining numerals.



### OpenType

OpenType fonts are suitable for use on multiple computer platforms. They are scalable fonts specifically created for use in digital design. They retain the integrity of the original typeface without becoming distorted when used across different computer platforms.

### Roman

The roman form of a typeface is considered to be the standard, upright version of a font. It is sometimes referred to as the 'parent' type of the typeface family.

### Serif

A serif is the small visual element at the end of a stroke. The serif is thought to aid the readability of a typeface and dates from Classical Rome. There are a number of serif styles including bracketed and non-bracketed serifs, slab serif, slur serif, wedge serif, hairline serif and rounded serif.

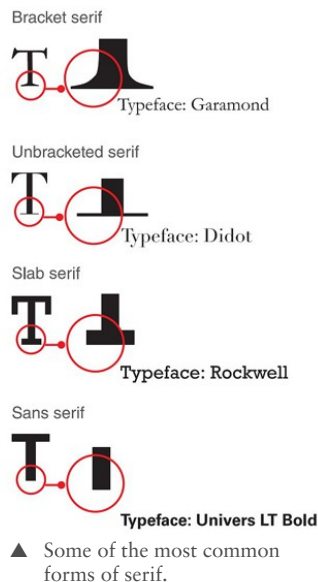

### Stroke

The main construction lines of a letterform. A has three, W has four and U has one.

### Spacing or tracking

Spacing and **tracking** refer to the distance between all letters in a sample of text. Normal tracking leaves the spacing as the type designer intended. Negative tracking moves letterforms closer together, and positive (or open) tracking moves them apart.



### Swash

A swash is the elongated entry point or exit point of a letterform usually seen in script typefaces.



### Terminal

This is the end point of a stroke that does not finish with a serif. A terminal often has a slightly heavier visual weight to balance the letterform, for example serif versions of lower-case f and r.

## Type size

Points are the units of measurement used in typography. One point is  $\frac{1}{72}$  of an inch or 0.352 millimetres. Point refers to the height of the type block rather than the letter itself.

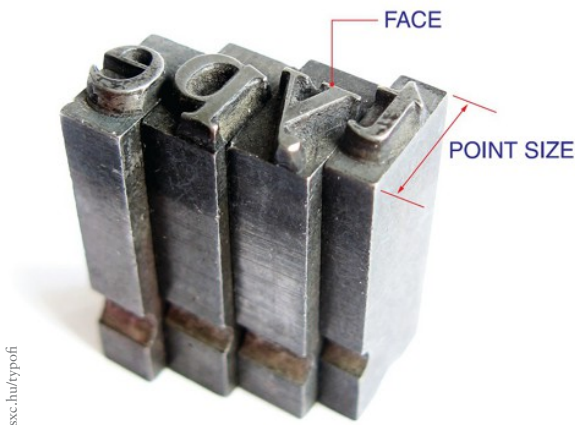

sxc.hu/typofi

## X-height

The x-height of individual typefaces varies widely. Here we show three similar serif faces that have very different x-heights.



- ▲ Garamond, Times New Roman and Georgia, all set at the same point size. Note that all have different x-heights. This variation should be taken into account when working with multiple typefaces in a **composition**.

## TYPE FOUNDRY

Although it sounds like a factory from the Industrial Revolution, a contemporary type foundry is a business that designs or distributes typefaces. Historically, typeface foundries manufactured and sold the metal type required in typesetting. Today, digital type foundries sell typefaces online and may also distribute the work of freelance type designers.

FYI

## TYPE CLASSIFICATION

Categorising typefaces can be difficult. All faces have distinctive characteristics, which are known as earmarks. The distinctiveness of earmarks enables us to distinguish between typefaces. Differentiation can be found on the upper-case Q, the upper-case G and also the ampersand (&). Other features that might assist in recognising typefaces are proportional differences; the variation between x-height and descenders/**ascenders**, for example. It takes a great deal of practice but in time you will find that you can distinguish differences between typefaces and this in turn will assist you in selecting the most appropriate typeface for your design task.

### Blackletter

A heavy style, reminiscent of the ornate calligraphic style prevalent in the Middle Ages. This style was used in early type printing and is also known as Old English, Brokenletter and Gothic.

## Blackletter: **Blackmoor**

### Humanist or Old Style

First created in the 15th and 16th centuries, the classical calligraphy of the ancient Romans was the inspiration for this typographic style. Examples include Trajan, Garamond and Caslon.

## Humanist/Old Style: **Garamond**

### Transitional

Transitional typefaces have sharper serifs and a pronounced vertical axis on the curves. Baskerville is a good example of a transitional style as it has considerable width in proportion to its x-height.

## Transitional: **BASKERVILLE**

### Modern

Designed in the 18th and 19th centuries, modern typefaces were controversial for their time. They



feature strong contrasts between thick stems and thick strokes. Bodoni and Didot are notable examples.

## Modern: **BODONI & DIDOT**

### Slab serif (also known as Egyptian)

Egyptian or slab serif type was introduced in the 19th century and was used extensively in poster advertising.

### Slab Serif/ Egyptian: **ROCKWELL**

### Humanist sans serif

Sans serif typefaces became common in the 20th century. Many used humanist proportions and references to Classical style. Notable examples are Gill Sans and Optima.

## Humanist Sans Serif: **GILL SANS**

### Geometric sans serif

Based on the modernist principles of the Bauhaus, geometric sans serif type used geometric shapes as integral aspects of the typeface design. The use of circles and squares was common. Examples include Futura and Johnston.

## Geometric Sans Serif: **FUTURA**

### Transitional sans serif

The most famous of all the transitional sans serif typefaces is Helvetica. The consistently upright nature of its characters reflects earlier transitional serif typefaces. Similar fonts are Arial and Univers.

## Transitional San Serif: **HELVETICA**

### Script

Based on calligraphic handwritten type, script faces are also known as copperplate. They are not used as body text and are most commonly used for titles on invitations or menus. Examples are Edwardian Script or Berthold Script.

*Script: Edwardian Script*

### Decorative/Graphic

Decorative type is used for novelty and may appear on signage, invitations or advertising materials in small doses. It is not recommended for **body text**. Examples are varied and include handwritten typefaces such as Comic Sans and quirky graphic styles such as Jokerman and Curlz MT.

*Decorative: CURLZ MT*

*Graphic: Comic Sans*

### Digital type

Designed specifically for online legibility, digital fonts such as Verdana and Georgia have simple curves, increased x-height and more open forms than print typefaces.

## Digital: **VERDANA**

### LOREM IPSUM

FYI

When preparing a mock-up of a composition, designers often use 'dummy' text rather than actual text. Dummy text leads to fewer distractions while the effectiveness of the design as a visual communication is being assessed. The most commonly used dummy text is known as 'Lorem ipsum'. This is an excerpt in Latin from a book on ethics written in 45 BCE by Cicero. It begins: 'Lorem ipsum dolor sit amet, consectetur adipiscing elit, sed do eiusmod tempor incididunt ut labore et dolore ...'

### LEGIBILITY

The purpose of typography is to communicate language. Legibility is extremely important. Type is often used for visual effect but its main purpose is to be read.

There are some effective ‘rules of thumb’ when considering legibility. One is to avoid using more than three typeface families in a design. Too many different typefaces can distract from the meaning of a visual message and can make a design product difficult to read.

The selection of typeface is of primary importance; the face should suit the context of the design product. It would not be suitable, for example, to set a formal document such as a financial institution’s annual report in a graphic typeface such as Comic Sans. Similarly, to set an invitation to the opening of a children’s play centre in a formal script would not suit the style or context of the event.



- ▲ Legibility. Same menu, same text, but note the difference between the two designs. The design on the right uses two typefaces (Trajan Pro and Avenir) only; adjustments to alignment, leading and point size increase its legibility as well as its aesthetic appeal.

**LINK: TYPOGRAPHIC POSTERS**

An online showcase of contemporary typographic design, the [typo/graphic posters website](http://vcd.nelsonnet.com.au) features designers from across the globe. You can link directly via <http://vcd.nelsonnet.com.au>.

The use of kerning, tracking and leading are important factors in creating legible type. Especially important in body text, the distance between letters and lines of type will influence how easily a reader can follow the flow of words. Headlines and titles will often be set with greater spacing and leading to create impact and draw attention to the type.

When type is treated as an image, legibility may take a back seat. Many designers use type purely as a graphic form to create visual impact within a composition.

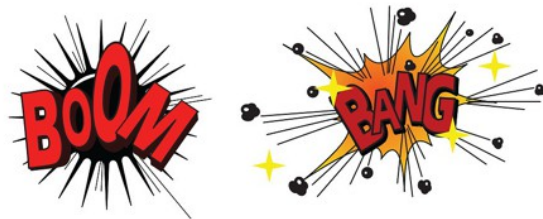

- ▲ Comics use type in a highly graphic way to communicate an event.



- ▲ The use of shapes within the typeface and a distinctive colour serve to reinforce the environmental message of this logo.

**QUICKVID: CHANGING TYPE FOR VISUAL EFFECT**

Watch a video demonstration of type alteration for visual effect, using Adobe Illustrator. Go to <http://nelsonnet.com.au>, then using the login code from the back of your student book, go to this title and click on Resources. Find page 121, and click on the video.





Vectorstock/Ceppecto

▲ Cleverly, this motorcycle company uses type to convey the concept of a motorcycle jacket, while also creating a corporate identity in a highly graphic style.

## Logo design

Reproduced with permission of Victoria and Albert Museum



▲ Logo of the Victoria and Albert Museum, London, designed by Alan Fletcher in 1979.

Many logo designs use type in both legible and abstract ways. A logo that uses type alone (usually the company initials) is known as a monogram. Using letterforms rather than images, a monogram can describe or ‘brand’ an organisation, forming its corporate identity.

Many corporations use type alone to identify their organisations. Many typefaces are described as having their own personality, derived from their appearance, historical background and common applications. In branding a business or organisation, selecting an appropriate typeface can be a challenging and complex process. Major organisations often commission their

own typeface. *The Age* newspaper uses the Utopia typeface, created especially for it.



IBM logo reproduced with permission

▲ In 1972, IBM introduced a new version of the logotype. Designed by Paul Rand, horizontal stripes now replaced the solid letters to suggest ‘speed and dynamism’. The basic design has remained constant, and is today one of the most recognised logotypes in the world, and a design that has been widely imitated by others.



ANZ logo reproduced with permission

▲ ANZ logo designed by M&C Saatchi 2009

### LINK: INTERNATIONAL SOCIETY OF TYPOGRAPHIC DESIGNERS



This is an international organisation, with a significant chapter in Australia, which aims to inspire interest in typography. Membership is limited to practising designers and typographers who can demonstrate a high level of skill in their application and design of type.

### LINK: OLD SCHOOL NEW SCHOOL



A typography school based in Melbourne, OSNS, offers short courses, collaborative projects and a retail store.

You can link to the website directly via <http://vcd.nelsonnet.com.au>.

# HISTORY OF TYPOGRAPHY

	Jenson			Avant Garde	
	Garamond		Didot	Helvetica	Calibri
<b>Gutenberg's 42 line Bible</b>	<i>Aldus Italic</i>	Baskerville	Bodoni	Gill Sans	Myriad
	Aldus Roman	Times	Franklin Gothic	<b>Futura</b>	Georgia
<i>1450</i>	<i>1500-1700</i>	<i>1700-1800</i>	<i>1800-1900</i>	<i>1900-1960</i>	<i>1960-</i>
<i>Blackletter</i>	<i>Classical Old Style Humanist</i>	<i>Transitional</i>	<i>Modern</i>	<i>Modernist (Swiss Modern)</i>	<i>Contemporary Digital</i>

▲ Simplified timeline of modern typography by style.

## EARLY BOOKS

In ancient civilisations, pictographic representations of language were common. Hieroglyphs, or symbolic representations, of words were used to convey meaning.

The printing of characters using carved wooden blocks can be traced back to 10th-century China, Korea and Japan. Images, symbols and Chinese characters were carved into a single block of wood and printed onto handmade paper.

Before the 15th century, books and documents were written by hand using ink on paper or parchment. Scribes and artists created single copies of books that were often highly ornamental and featured hand-painted images and decorative borders. Gold or silver gilding was often added, leading them to be called 'illuminated manuscripts'. The scribes used a calligraphic style of letterform and it could take a scribe more than 20 years to produce a single book. These books were most commonly produced for the Catholic Church or for wealthy patrons. In the 14th century the earliest European universities commissioned handwritten manuscripts in this style.

## GUTENBERG AND THE PRINTING PRESS

Typography, as we know it, came into being around 1450. Johannes Gutenberg (1398–1468) is credited with inventing the first printing press in the West, using 'moveable type'. Gutenberg cast individual letters

from metal that could be rearranged according to the text, and used oil-based ink that adhered to metal. He was then able to print multiple copies of documents on the printing press.



▲ Nineteenth-century lithograph of Gutenberg and his press.

Arguably, Gutenberg's most famous printed document is the *Gutenberg Bible*. It was significantly cheaper and easier to produce than handwritten copies. The bible was printed in a typeface reminiscent of handwritten script. Gutenberg's printed works featured the Blackletter typeface. This typeface was a deliberate recreation of the handwritten calligraphic style of medieval manuscripts.

Moveable type is defined by the use of individual characters or 'glyphs' including punctuation marks, which can then be moved about to create words and sentences. Many of the typographic terms we use today originate from the invention of this 15th-century method.

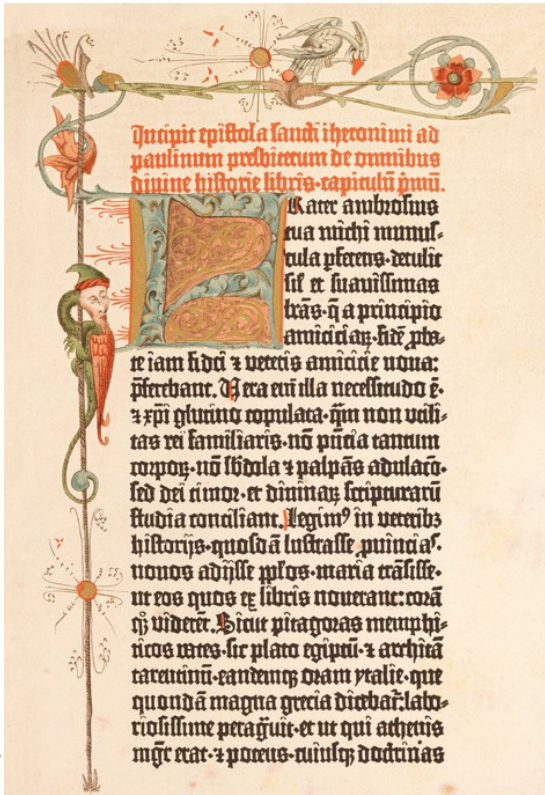

iStockphoto/Ralf Hentler

▲ Page of the *Gutenberg Bible* printed in 1455, also known as the 42-line bible.



Wikimedia Commons/Wilfrid Heidebach

▲ Moveable type.

## EARLY TYPEFACES

Following Gutenberg's death in 1468 and the subsequent spread of his invention, printing and the use of moveable type expanded rapidly.

From the 16th century onwards, there was a proliferation of new typefaces. Though still hand-carved and then cast in metal, the new typefaces showed a consistency of width and size. Influenced

by the values and artistic styles of the Renaissance, these early typefaces demonstrated key typographic principles. Many of them, including Garamond, Times and Jenson, are still in use today. Often referred to as roman, old style and humanist typefaces, these serif type families are highly legible and ensure that each character works visually with any other character. Roman typefaces refer to a classical style of letterform, most famously seen on Trajan's Column in Rome.



iStockphoto/Andrew Kaupang

▲ THE INSCRIPTION ON TRAJAN'S COLUMN (113 CE), IN ROME, IS AN EXAMPLE OF THE CLEAN ROMAN STYLE THAT INFLUENCED RENAISSANCE-TYPE DESIGNERS SUCH AS JENSON. THE SERIFS SEEN ON THE COLUMN TEXT WERE FORMED BY THE INITIAL MARK OF THE STONEMASON'S CHISEL. THIS CAPTION IS SET IN A CONTEMPORARY VERSION OF THE STYLE CALLED TRAJAN PRO.

## DEVELOPMENTS IN THE 18TH AND 19TH CENTURIES

Eighteenth-century British printer William Caslon established a successful printing business with his sons, creating typefaces with crisp and upright elements, which appeared lighter and more refined than their Roman counterparts. Across Europe, typographers

such as Baskerville, Bodoni and Didot were experimenting with typographic elements to produce extreme contrasts between thick stems and slight serifs. The final results were often controversial but enduring. Driven by commercial imperatives, printers and typographers moved quickly from the calligraphic, handwritten traditions of earlier typefaces and worked to, quite literally, stamp their personal mark upon type design. Many classic typefaces in use today bear the names of their creators; for example, Aldus, Caslon, Baskerville, Clarendon and Bodoni.

The rise of the Industrial Revolution also influenced the design of type. The bold, highly contrasting faces of Bodoni and Didot gained traction as the power of print advertising grew. Bold letterforms on posters and signage dominated the design of advertising posters competing for attention in the growing urban landscape. Slab serifs and elongated or distorted letterforms were common. Large letterforms were often carved from wooden blocks while smaller type remained cast in metal. Dominated by serif typefaces,



▲ *The Melbourne Morning Herald*, 11 November 1850.

Nelson Visual Communication Design VCE Units 1–4

the first sans serif typeface was created in 1815 by William Caslon IV. Initially controversial, sans serif type can be seen on advertising posters of the 19th century, though often heavy with embellishments.

Monotype and linotype machines were introduced in the mid-19th century and established a mechanised approach to setting type. Though complex in their functions, the machines increased efficiency and enabled lines of type to be produced more rapidly.



▲ Linotype machine.

## TWENTIETH-CENTURY MODERNISM

With the growth of modernist movements in the 20th century, the clean aesthetic sensibility of modernism also influenced typographic design. In many cases, clarity and function were at the forefront of modernist typography, as modernists rejected the decorative type of the previous century. At the turn of the 20th century, the sans serif face called Franklin Gothic was created.

In 1913 Edward Johnston designed the sans serif signage of the London Underground transport system. The typeface (Johnston's Railway Sans) was striking not only for its clarity and simplicity but also for its consistency, as few transport networks had used any consistent typography before this. Similar to other modernist type designs of the time, it uses a perfect circle as an 'o' and geometric squares as dots for lower-case 'i'

ISBN 9780170401784

and 'j'. An updated version of the Johnston typeface (New Johnston) is still used by the London Underground and has influenced the signage systems of many world cities.



iStockphoto/Chris Schmidt

▲ Signage for Oxford Circus underground station in London. The London Underground uses an updated version of the Johnston typeface called New Johnston.

Members of De Stijl in the Netherlands and Bauhaus in Munich each developed typefaces that were reduced to simple, geometric representations of letterforms. German designer Paul Renner designed Futura, a face that remains as contemporary as it was in 1927. Like Johnston, the perfect roundness of Futura's 'o' strongly reflects its geometric roots. In 1928 book designer, typographer and teacher Jan Tschichold published *Die Neue Typographie*, a design manifesto that detailed the idea of simplicity, clarity and functionality in type design. He strongly supported the use of sans serif type and even described a preference for lower-case letters alone.

In the United Kingdom, as in Europe, the design of type rapidly embraced modernist design principles and Eric Gill, a gifted artist, sculptor and stonemason, and associate of Edward Johnston, developed his widely used Perpetua and Gill Sans to wide praise.

Following the Second World War, advances in printing techniques saw the creation of phototypesetting. This enabled the printing of many more characters with more efficiency than prior typesetting methods. The advances in printing coincided with the design of many typefaces that are used today. Helvetica, designed in 1957 by Max Miedinger, remains one of the most popular sans serif typefaces of all time. It is reflective of the Swiss Style; a clean and modernist design aesthetic that evolved in Switzerland in the 1950s.

ISBN 9780170401784

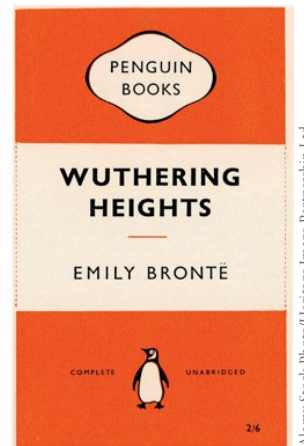

Alamy Stock Photo/Heritage Image Partnership Ltd

▲ Tschichold was one of the most influential typography and book designers of the 20th century, famous for his redesign of Penguin's book covers. Tschichold implemented a rigorous system where series covers retained the same elements; an approach still used in book series design today.

Univers, designed by Adrian Frutiger also in 1957, typifies the efficient, universal appeal of the Swiss Style, although Helvetica quickly became more popular.

The 1950s and 1960s saw graphic design emerge as a separate discipline. The design and layout of printed products became a specialist area for trained designers whose expertise extended to the effective design of type.

## DIGITAL DESIGN

As computer-based design developed at the end of the 20th century, typesetting became a digital skill rather than a manual one. Computer-aided design gave designers more flexibility in the composition of type and a vast selection of new, digital typefaces. Software developments in the late 1980s, including Fontographer, enabled typefaces to be created by entirely digital means. Designers could also use vector software such as Adobe Illustrator to manipulate and distort typefaces. Ultimately, layout programs such as InDesign and Quark (also called desktop publishing or DTP), enabled designers to compose and adjust type efficiently and inexpensively.

## HANDWRITTEN TYPE

Since 2000, the renewed interest in handmade design products has seen a similar resurgence in this kind of typography. As a contrast to a perceived sameness in computer-aided design, some designers have developed

Nelson Visual Communication Design VCE Units 1–4



expressive and unique work using combinations of media and handwritten type. Contemporary handwritten type can often be seen on clothing, editorial illustrations and promotional posters. Hand lettering is an expressive and informal kind of typography that has been used in one form or another throughout time. Handwritten signage, and hand-drawn posters and flyers, have been an inexpensive means of promotion. Before affordable home printers, hand lettering was the only means of production for amateur designers. Many promotional posters for bands and independent art and design events were produced by hand. Such an artisanal approach has seen a resurgence in the maker movement.

### LINK: STEPHEN BANHAM

Founder of renowned type design studio Letterbox, Stephen Banham has written a fascinating short history of Australian typographic design from 1986–2016. Established in 1991 Letterbox undertakes typographic projects commissioned by clients (identity systems, signage systems, book design and font customisation) along with other projects such as publications, installations and exhibitions. You can link directly to Letterbox via <http://vcd.nelsonnet.com.au>.

## Gemma O'Brien

Australian designer, artist and typographer Gemma O'Brien uses a distinctive hand-drawn typographic style. Her typography and illustrations have been used in advertising campaigns, identity designs, animations and as artistic works. She uses a mix of traditional techniques and unconventional materials to create her work from airline sick bags to wall murals to neon signage.

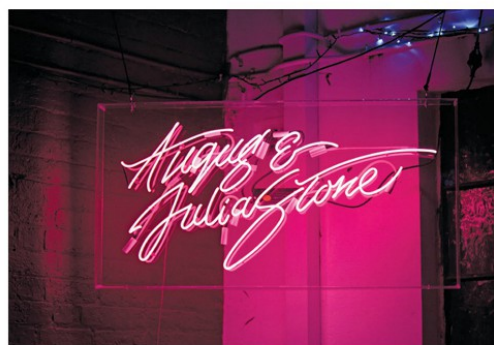
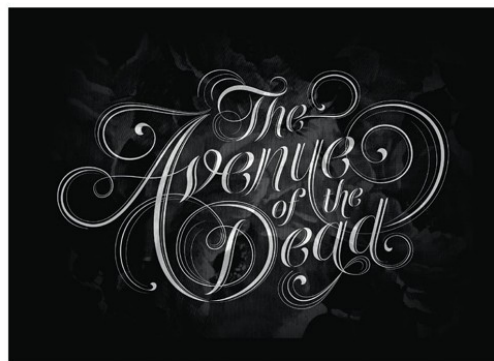

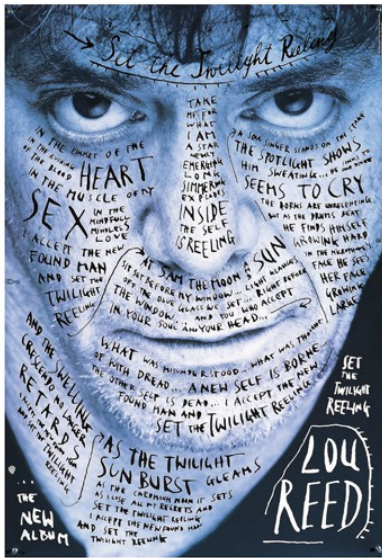

▲ 'We designed a poster announcing the new album of Lou Reed. The lyrics are extremely personal. We tried to show this by writing those lyrics directly over his face.' Art direction and design by Stefan Sagmeister and photography by Timothy Greenfield Sanders, for Warner Bros Music Inc. Size 680 mm × 984 mm. Date 1996.

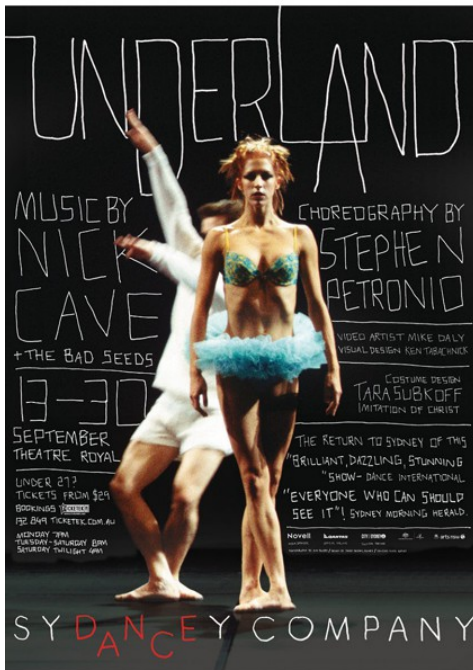

▲ Poster for Sydney Dance Company by Frost\* Design. Vince Frost, Creative Director – Frost\* Collective; Caroline Cox, Designer – Frost\* Collective; Jeff Busby, Photographer

ISBN 9780170401784

## THE COMIC SANS CONUNDRUM

FYI

To use or not to use? *Comic Sans* has become the whipping font of the Internet. Sites are dedicated to recording the many, varied applications of a typeface that polarises opinion. It is interesting to know that *Comic Sans*, created by Vincent Connare, was originally designed for use in the early Microsoft Windows help icons. A helpful cartoon dog or paperclip offered assistance to users of software such as Word or Excel. Connare believed that the heavy, serif font used in the characters' speech bubbles did not match the light-hearted cartoons. He designed *Comic Sans* as an alternative. Ultimately, the typeface was also added to the standard Windows installation and has found favour (and controversy) with users ever since. Connare's intention for the font provides an important insight into the much maligned *Comic Sans*; there is a time and a place for every font. You can very clearly differentiate between those who have a deep knowledge of design and those who don't by the typeface selection. As with all other design elements and principles, your choice of type requires thoughtful application.

## LAYOUT

In both digital and print, composition refers to the layout of type, image, design elements and principles in a space. The effective placement of content such as text and images and the organisation of visual information involve considerable planning.

## GRID

When creating a composition, the application of type, image and other visual elements is often managed within a visual **grid**. A grid is an invisible structure that supports the layout of print and digital content. A designer will use a grid to create hierarchy within a design composition and to delineate the placement

Nelson Visual Communication Design VCE Units 1–4

of text and image. Grids can be seen in newspapers, magazines, webpages and even mobile devices. The grid can be a powerful tool when used well; it can draw the eye through a composition and create strong visual relationships between type and imagery.

**QUICKVID: SETTING UP A GRID**



Watch a video demonstration of grid set-up using a range of familiar software. Go to <http://www.nelsonnet.com.au>, and use the login code at the back of your book. Click on Resources, go to page 130 and watch the video.

**Columns**

**Columns** provide a sense of order in a design. They are vertical ‘containers’ that hold text and visual elements.

The width and number of columns in a composition is established in the planning stages.

**Flowlines**

These are the horizontal grid lines that define areas for the placement of type and images. The combination of column and flowline creates the **modules** of the grid.

**Gutter**

The **gutter** refers to the spacing between columns. It is also used to describe the space between pages, near the binding, in a book or magazine.

**Margins**

**Margins** are the white space that surrounds a composition and separates the design/artwork from the edge of the composition. Printed compositions allow enough space in the margins for the page to be cut (trimmed).

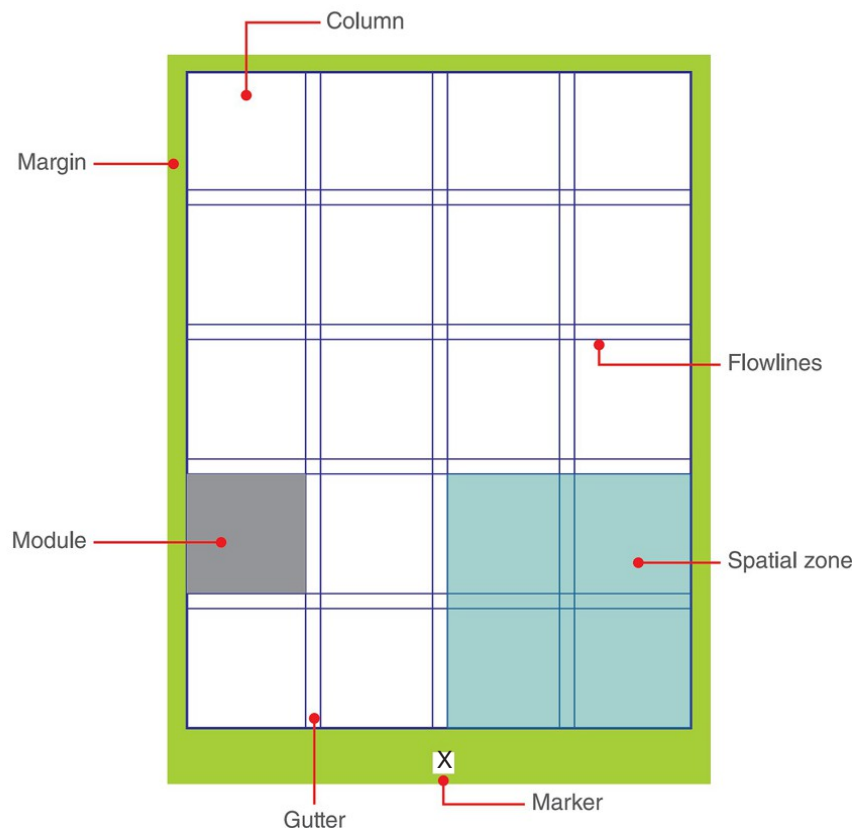

▲ The main components of a grid.

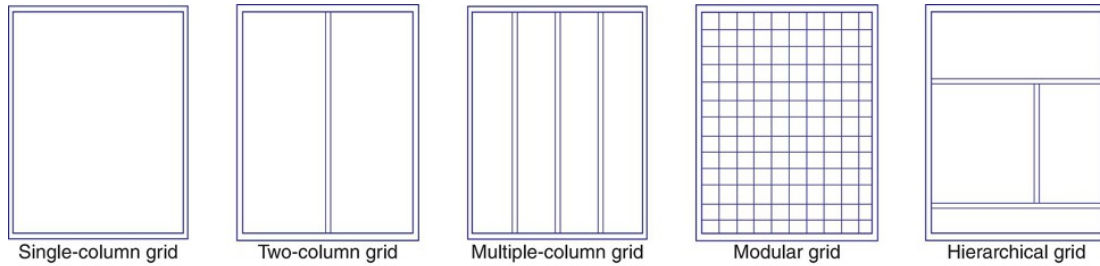

▲ Some common grid formats.

### Marker

A **marker** is a repeating element that assists navigation on a page. It may be a page number, footer or even an icon.

### Modules

Modules are the grid areas defined by the columns and flowlines. These are the spaces that may contain

text or images. Multiple modules create spatial zones.

Interestingly, many striking designs have been created by designers ‘breaking’ the grid. This involves challenging the ‘rules’ of composition while maintaining visual balance and harmony.



▲ Webpage design. The left image shows the modular grid used by the designer to create the final webpage. It is possible to see how some elements use single modules while others use larger spatial zones.



## ALIGNMENT

Alignment is the placement of elements in relation to one another. When using word-processing software, you may have used the text alignment tools, which enable you to justify (align) your text to the left, right or centre of your page. These tools can give your text and images a sense of order and organisation that keeps the message clear. Alignment tools exist in all graphics software packages.

Effective use of alignment demonstrates that your composition is organised and implies that elements have relationships with other elements and images. Establishing a relationship between elements helps to lead a viewer's eye to – and through – your design. Elements and images placed without organisation will appear lost and unrelated to the composition.

## CHAPTER RECAP



- 1 Use magazines or newspapers to collect examples of the following **type styles**: serif, slab serif, handwritten, decorative, sans serif and script.
- 2 Identify your sources/attributions. Add the baseline and x-height to each example.
- 3 Designer Gemma O'Brien uses a distinctive calligraphic style in many of her typographic works.  
Explain how her particular style is protected under copyright law. (Refer to Chapter 13)
- 4 Define the following terms: leading, kerning, tracking.
- 5 Find an example of a serif typeface. Identify the following: bowl, ear, terminal, descender, ascender, serif and loop.
- 6 Create a typeface using non-type imagery. Use shapes, photographs or torn paper to build 26 type characters and 10 numerals.
- 7 Take a screenshot or print a website of your choice. Using line, identify the grid that has been used.



# MEDIA, METHODS AND MATERIALS



---

## In this chapter:

+ Drawing methods .....	134
+ Printing methods.....	140
» Manual printing methods.....	140
» Digital printing methods .....	142
» Paper quality .....	142
» Three-dimensional processes.....	144
+ Digital design .....	147
» Image types.....	147
» Key aspects of digital imaging software .....	148
» Anti-aliasing .....	152
» Preparing images .....	152
» Resolution.....	152
» Image types.....	153
» Colour management .....	154
+ Photography.....	155
» Tips for taking good photographs.....	155
» The camera .....	157

## Learn the language

bitmap	construction	modelling	stock
CAD/CADD	file types	raster	substrate/surface
colour mode	mixed media	resolution	vector

---

## DRAWING METHODS

Drawing lies at the core of visual communications and offers endless possibilities for the visualisation and presentation of design **concepts**. Drawing and **rendering** allows you to express the development of design ideas in a visually meaningful and effective way.

Drawing creates a visual language and can provide detailed information about the **construction**, workings and appearance of objects. At times, you may wish to express complex visual messages through drawing. The integration of visualisation drawing techniques, appropriate media and **materials** can facilitate this.

### Observational drawing

Observational drawing is freehand drawing that requires the direct observation of objects, environments or structures to represent form, proportion, materials and textures effectively. Observational drawing can communicate structural detail and function. Observational drawings may incorporate naturally observed perspective.

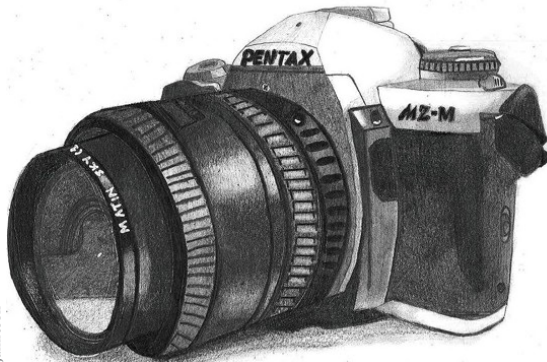

Meg Jamieson



Grace Mills

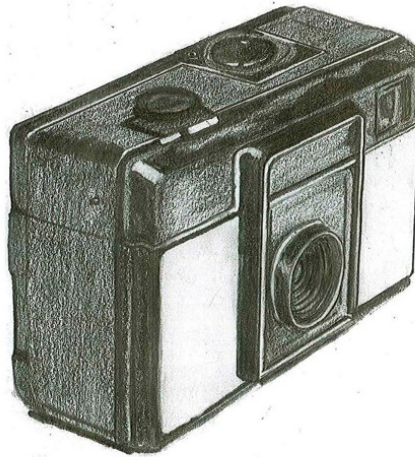

Johanna Schreiner

### Visualisation drawing

Drawing from imagination supports the generation of ideas. These drawings are in the form of quick freehand sketches aimed at conceptualising and communicating ideas. Drawings may be developed in two or three dimensions. They may also include explanatory sketches and diagrams.

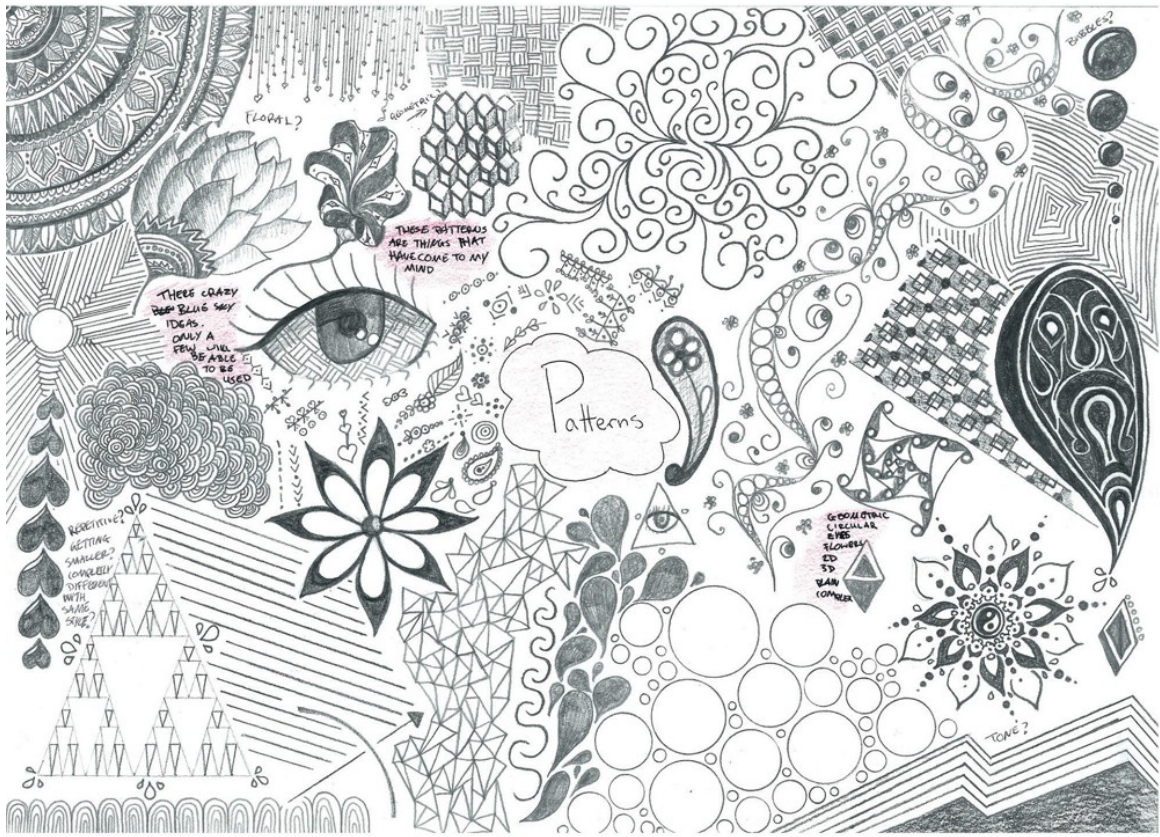

## Presentation drawing

Presentation drawings present design concepts and final design solutions. They are refined and finished drawings and may employ either manual or digital media applications. **Methods** of production may

include perspective or paraline drawings (three-dimensional), and/or third-angle orthogonal projections (two-dimensional).

(For detailed information about drawing techniques, see Chapter 1.)

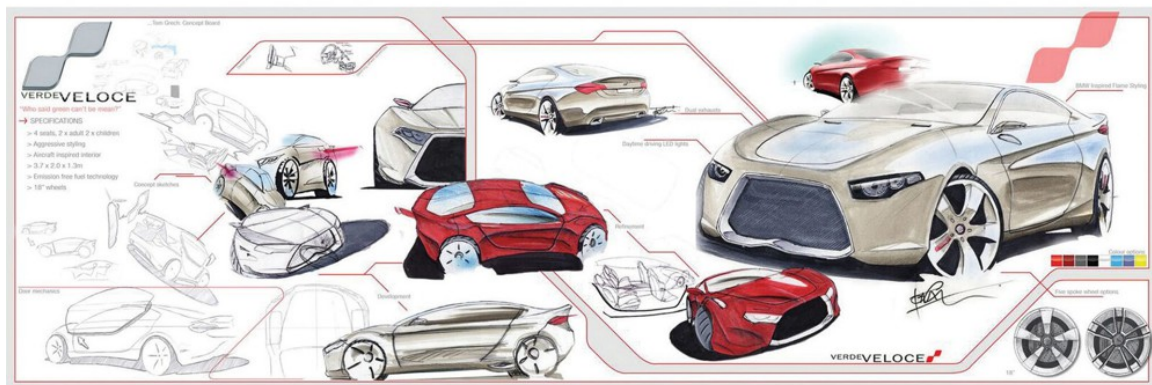



## Pencil

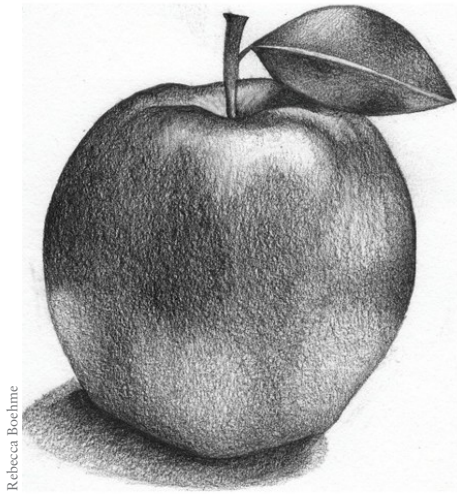

Rebecca Boehme

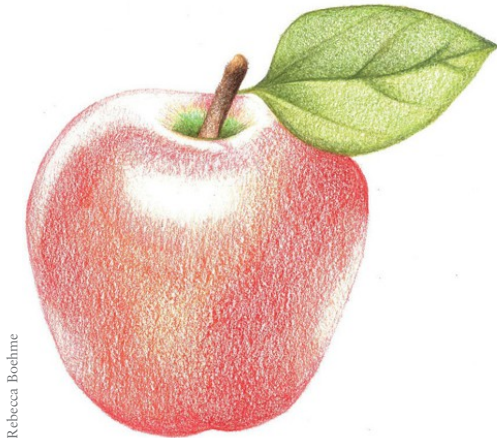

Rebecca Boehme

The effect of pencil work is determined by three factors: the angle of use, the pressure of application and the **surface** texture. Each variable will affect the appearance of pencil illustrations. Pencils are a deceptively simple medium and because they are so familiar to us, we sometimes ignore their versatility. Pencils that contain a soft core are most effective for illustrations and freehand drawings.

Applying turps with a soft brush to high-grade coloured pencil work to create a wash can enhance pencil rendering. The application of watercolour pencils may also soften an image. The pigment contained within watercolour pencils is soft and dissolves easily with water applied with a brush or sprayed from a bottle.

## Application ideas for pencil

Sketches, idea generation and development, illustrations for packaging, product design, concept drawings, images for print publications, images for the Web, illustrations for posters, brochures, diagrams, maps, charts. Coloured pencils work well with markers, biro and ink pens for interesting illustrative effects and emphases.

## Watercolour



Rebecca Boehme

Watercolour paints contain a coloured pigment suspended in a water base. They offer soft, transparent effects when applied and are usually used on special watercolour papers. There is a range of special application techniques used when working with watercolour, including washes, glazes and wet-in-wet techniques. Watercolours are often used in combination with drawing and printmaking.

Watercolour (also known as aquarelle) pencils and pastels are easier to use than traditional watercolour as they can be applied like a straightforward pencil and then altered with the addition of water. Watercolour pencils are effective when rendering objects and illustrations. Watercolour paints can be applied from tubes or convenient disc palettes. Use on watercolour paper for traditional effects, or use other paper types for visually interesting results.



opaque or translucent washes. With the addition of additives such as impasto medium, a thick textured consistency can be achieved, and acrylic can reflect the qualities of media such as oil paint. Unlike oil paint, acrylic does not reflect light when scanned or photographed so is ideal for use in illustrations for posters, books and so on.

### Application ideas for gouache and acrylic

Poster design, packaging surface graphics, diagrams, maps, identity design and symbol design, magazine covers, backgrounds, patterns and illustrations for editorial content.

### Pen and ink



The making of marks with pen can create a vast spectrum of visual effects. From closely linked lines that are crosshatched and interwoven to sparse ink and brush works, the suggestiveness of these two media is endless. Simple black-and-white line drawings can be deeply expressive – in most cases the quality of the line will create the meaning of the drawing. Sweeping organic lines have a different effect from strong, boldly drawn crosshatched lines.

Pigmented inks are deeply coloured and can be used with a pen nib, brush or airbrush. They offer striking colour coverage and can be mixed and blended on paper for visual effect. Ink line work – using a combination of black Indian ink and pigmented coloured inks – offers

many illustrative possibilities and is popular with many illustrators, cartoonists and fine artists.

### Application ideas for pen and ink

Cartoons, comics, illustrated novels, editorial illustration, book illustration, technical and scientific illustration, maps, diagrams, Web content, [animation](#), backgrounds and patterns.

### Oil and chalk pastels

Pastels are ideal for expressive and emotive illustration. The qualities of oil pastels and chalk pastels differ greatly but the application is remarkably similar. Both are often applied in layers, with scraping and blending used to remove or define areas. Pastels can be feathered, where long and short lines of colour are used to weave colours into one another. Oil pastel can be used with pure turpentine as a solvent to create diluted washes.

Chalk pastel can be scraped with a sharp blade and the flakes mixed with fine white talc to create soft backgrounds and effects. The mixture should be applied with cotton wool or a tissue. Used in combination with masking film or paper, areas can be wiped with the mix to form a contrasting background for product designs.

### Application ideas for pastel

Illustrations for children's books, illustration for print publications, background effects for the presentation of product designs.

### Collage using paper and card

Cut and torn paper offers many illustrative possibilities. The array of specialty and handmade papers available provides a variety of weights and textures. Paper lends itself to tearing, crumpling, layering and cutting. Paper exists, of course, as the medium for the basis of our drawings and designs but its qualities offer many other creative possibilities.

Tracing paper can be used not only for tracing but also as a printing surface. Due to its translucent qualities, it can be used as an overlay or divider.

Cotton and fibre papers, also known as rag paper, are ideal for printing watercolour and acrylic media, as their absorbent characteristics can create soft washes.

Paper and cards such as pasteboard come in a range of weights (thicknesses) and can be used to



Mikaela Revell

construct models, point-of-purchase displays and packaging prototypes.

### Application ideas for paper and card

Illustrations that demand contrast, pattern, texture, colour and shape; layering to develop three-dimensional modelled imagery; development of a logo design; menu design.

### Collage using mixed media

Collage is a spontaneous method of arranging visual materials in a unique way. Found objects, clippings, photographs, images and varieties of paper might be



Mikaela Revell

ISBN 9780170401784

used in combination to create thematic presentations or visual contrasts. When used well, collage can create contemporary, youthful and 'edgy' illustrations for postcards, magazine layouts and book covers.

Collage may contain combinations of type, colour and relevant images, and may be used in response to a communication need. Collage can become a rich representation of a theme or idea, whether working with comics, handmade and textured papers, sheet music, stamps, maps, playing cards, wallpaper, postcards or other materials with interesting visual characteristics.

### Application ideas for collage

Illustration for a poster or magazine cover; presentation of materials, fabric and design ideas for an interior design; illustration for postcards, packaging or posters.



Eleanor Shakespeare

▲ Collage and digital media combine in this magazine cover by illustrator Eleanor Shakespeare.



Madison Marshall

▲ Using textures and images torn from old magazines, this student created a collage to describe an experimental design for an interior design task.

## Markers

Rendering with markers is a quick way to create tone, texture and surface detail. Markers use a highly pigmented ink that can be applied with a thick, thin or brushlike applicator. Best used on bleedproof paper so that the colour doesn't bleed into paper fibres, markers can be used on other media for effect. Available in many colours, the application of markers can provide tonal variations, and they are often used in the generation and development of ideas. Markers can be seen in many sketches by product designers, graphic designers and fashion/textile designers.

There are a variety of accessories available for markers including an airbrush adaptor for applying smooth gradients and tones.



Mark Wilken

▲ Marker and watercolour pencil on bleedproof paper.

### Application ideas for markers

Illustration of concepts in design sketching, development of design ideas; presentation of concepts; illustration of books, articles and finished artworks; illustrations for packaging or posters.

## PRINTING METHODS

There are many printmaking methods, all of which offer distinctive visual characteristics. Printing can be defined in terms of digital and manual production. Inkjet and laser printing as well as professional printing methods such as offset printing and large-format inkjet printing are used to create polished final presentations from digital files. Printing by hand using more traditional manual printmaking techniques can be used in Visual Communication Design to create bold illustrations as part of a design task.

### MANUAL PRINTING METHODS

#### Intaglio printing

Intaglio printing is the name for the processes of etching, mezzotint, engraving and dry point etching, where the pressure of printing forces the paper into the grooves of the plate to pick up the image. The intaglio plate has lines 'bitten' into it and these form the lines of the print. The plate is initially covered with

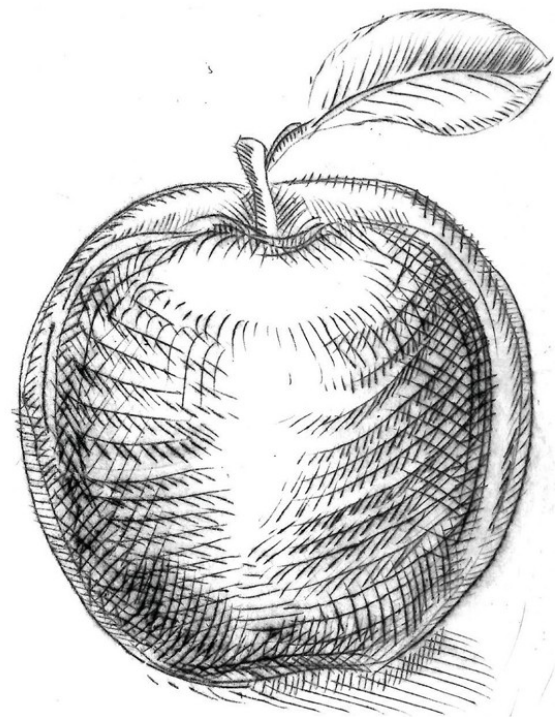

Rebecca Boehme

a protective coating of 'ground' such as bituminous paint, which is then drawn into with a needle-like etching tool. The plate is placed in acid and the acid etches the areas drawn into and not covered with ground. The plate is inked so that ink rests in the etched areas of the plate, and the remainder of the plate is wiped clean. Intaglio prints such as etching are printed using dampened rag paper. There are many techniques used in etching to create fine, soft finishes, sharp line drawings and dark, moody tones.

### Application ideas for intaglio prints

Surface graphics for packaging, illustrations for books, posters, drawings made from direct observation, book jacket design, movie posters, basis of animation for film titles.

## Monoprint

The simplest and most accessible form of printmaking is the monoprint. A monoprint is a one-off impression made by applying printing ink to a surface and then transferring it to paper. Monoprinting excludes the benefit of other printmaking methods in that multiple copies of a single image cannot be made; however, the visual characteristics of a monoprint are distinctive. A monoprint can be created on acetate, glass or cardboard. Ink is applied, and marks and textures are made on the inked surface. The monoprint 'plate' is then printed onto paper using a press or soft rollers. Although you cannot create multiple prints, you may



Rebecca Boehme

▲ A linocut relief print

ISBN 9780170401784

use the same plate two or three times and achieve an image that fades in intensity with each application.

### Application ideas for monoprint

Illustration for a book jacket design, CD cover or poster; background design for a website or **multimedia** presentation; illustration for children's literature.

## Relief printing

Linocut and woodcut techniques are referred to as relief printing. Sharp tools are used to carve the surface of a block or tile. Linocuts are probably the easiest form of relief printing as the surface is usually soft and can be carved without difficulty. Woodcut printing offers quite different surface qualities from smooth lino, as the texture of the wood is often visible in the final prints.

Ink is applied to the surface of the lino tile or wood block and the tile is printed onto paper using a printing press. The areas cut away from the original material remain white.

A similar but more 'sketched' and illustrative effect can be obtained through the use of scraperboard. This heavyweight paper is coated with a black surface that can be scraped away with a sharp tool to reveal the white surface beneath.

### Application ideas for relief printing

Logos, surface graphics for packaging, pattern and imagery for textiles and surface designs; signage; editorial illustrations for magazine articles; cartoons or comic strips

## Screenprinting

Screenprinting differs from other printmaking processes because the print is not the result of the direct impression of one surface upon another. Instead, a screenprint is formed by printing through a secondary surface, that is, a mesh screen. Screenprinting has a history as an integral part of commercial printing and has been used extensively as a medium for graphic and textile design. Screenprints can be created by using various forms of stencil techniques based on blocking out areas of the mesh with paper stencils or liquids that fill the mesh. Stencils may be cut from paper or flexible plastic film and placed on the screen. Ink is spread across the screen

Nelson Visual Communication Design VCE Units 1–4

and dragged across the mesh with a squeegee. The image that is reproduced on the paper beneath the screen depicts only the cut-out areas of the stencil. Photographic screens are used by commercial printers and fine artists and have the stencil printed permanently onto the screen. Multiple screens and stencils are required for multicolour screenprints.



Rebecca Boehme

### Application ideas for screenprinting

Textile design, fashion and T-shirt design, posters, flyers and brochures, logos, cartoons and comics, decals and decorative features, surface graphics, illustrations.

## DIGITAL PRINTING METHODS

The two main types of printers that you are likely to have access to are inkjet printers and laser printers. Inkjet printers precisely place tiny drops of coloured ink onto paper to create an image. The inkjet printer is known as a non-impact printer because it sprays drops of ink onto the paper and does not touch the paper itself. The laser printer is also a non-impact printer and uses toner (or dry ink), static electricity and high temperatures to position the image on paper.

### Inkjet printing

Inkjet printers are the most popular means of printing colour images for school and home users. They range from small A4 printers to very large format printers. It is possible to obtain high-quality prints without

the expense of professional printing processes. Inkjet printers generally use four or more colour cartridges, one for each of the CMYK colours cyan, magenta, yellow and black, or hue variations of these colours, for example light magenta, light yellow. Different percentages of each of the four colours can produce seemingly endless variations in colour. As your computer screen operates in RGB mode, it is helpful to have access to a colour swatch so that you can more closely identify the printed colour. Some swatches contain the CMYK percentages for each colour to assist in generating the appropriate colour in your chosen software package.

Colours you see on the screen are often different when printed. Colour always appears brighter on the screen. Commercial products that calibrate your monitor are available to ensure greater parity between your screen and the printed page. These are placed on the monitor itself and ensure that your colours remain true. A less expensive alternative is to test print your colours as you go, or use a colour palette swatch.

When using an inkjet printer, the variables that may affect your work are print resolution and paper quality.

### Print resolution

The number of dots per inch or dpi value of an inkjet printer will affect the clarity of the print. This value refers to the number of dots of ink placed on the paper within each inch of image space. A printer that produces 1440 × 720 dpi will print a higher quality image than a printer that prints 300 × 300 dpi.

### Laser printing

Laser printers can also vary in quality and you will find that some printers produce a clearer image than others. Often, laser printers do not produce the subtle tonal variations that can be seen in inkjet prints, and colour laser prints can appear flat. However, for reproduction of single colour letterform, logos and developmental work, the laser printer is quite suitable.

## PAPER QUALITY

Paper is also known as stock and refers to the surface a design is applied to. Paper stock can vary widely and is measured in terms of grams per square metre or 'gsm'. The higher the value, the heavier and generally thicker the paper.

## THE DIFFERENCE BETWEEN PPI AND DPI

FYI

**PPI** (pixels per inch) refers to pixels within an image and is related to screen resolution. For example, a 300 ppi image contains 300 pixels in each inch of image size. It is the preferred term when referring to the quality of an image. Note that images created at a low resolution such as 72 ppi cannot have pixels 'added' later to create a higher-resolution image, as the 'extra' digital data simply doesn't exist. This is why it is vitally important to establish the end purpose and subsequently the resolution of your images before you start.

**DPI** (dots per inch) is related to the printing of images using a printer. Generally, a printer uses four or more coloured inks to recreate images. Each pixel of the screen image is created by a series of tiny ink dots. A 1200 dpi printer, for example, will print 1200 dots of ink per inch of image. The higher the dpi, the better the print quality; however, the printer will use more ink and the print will take longer to execute.

Standard printer paper is usually around 80 gsm.

Weight	Paper	Use
80–90 gsm	Standard paper	For general printing, flyers, brochures, photocopies
120–190 gsm	Heavyweight paper	For photo prints, folded cards, posters and brochures
200–250 gsm	Extra heavyweight paper	Used for photo prints, artwork and packaging
300–400 gsm+	Card	Used for cards and covers. Some specialist packaging may use heavyweight card

There are many specialty papers available for printing. Domestic and business printers have a limit to the weight of paper that can be printed. Heavier stock, such as card, is usually printed by commercial printers using the offset process.

ISBN 9780170401784

To produce high-quality results, specialty laser and inkjet papers are treated with a vivid white coating, preventing ink from bleeding into the fibres of the paper and preserving the integrity of ink colour. When traditional 90 gsm papers such as photocopy paper are used the ink is absorbed into the surface fibre, which reduces not only the sharpness of the print but also the intensity of the colour.

Special coated papers are available in different surface types, similar to photographic papers, including gloss, satin and matte. It is also possible to print onto iron-on transfers, transparency sheets and adhesive films. Paper coating will affect how much ink or toner is applied to a print, impacting the colour.

Laser printers use toner rather than ink, which does not bleed, although it can smudge in heavily toned areas. Specialty papers are also available for laser printers and include transparencies, varnished papers (gloss, matte and satin) and some recycled and textured varieties in a range of colours.

The choice of paper will be determined by the purpose of the print and the suitability of the surface type for the task.

### TIP: DON'T JUDGE A DESIGN BEFORE IT'S PRINTED



When you are designing for print, make sure you check your colours on a printed copy and not on the screen. The print will always be darker than the screen and some colours may print very differently to what you expect. For the most accurate representation of colour on screen, use calibration tools or a colour swatch.

## Offset printing

Offset printing is a process used by professional printers. A digital file is converted to a series of 'plates', which are coated with ink. The plates travel through a complex printing press, which transfers the inked image on the plate to the chosen **substrate** or printing surface. Offset printing originates with digital files that have been prepared in line with the printer's specifications. A professional printer will indicate what is required in a printable file. Generally, the specifications include the **colour mode** (usually CMYK), the need for outlined type (to ensure type

Nelson Visual Communication Design VCE Units 1–4



looks as intended), bleed (to extend colour, image or type to the printed edge) and trim marks (where the paper, card or other stock is cut) as well as the stock on which the product will be printed.

The professional printer can also coat the printed stock with a varnish to create a matte or gloss appearance and provide binding of books and magazines. The complexity of offset printing means that clear communication between designer and printer is essential to ensure a successful outcome.

## THREE-DIMENSIONAL PROCESSES



Danielle O'Leary

At various stages throughout the Visual Communication Design course, you may choose to construct scale models of a product. The effective use of three-dimensional materials can lead to the production of models that communicate the form (and perhaps the function) of an object more clearly than a drawing or diagram. **Modelling** of designs can be completed manually or digitally by using 3D modelling software and printers.

### Three-dimensional printing

In recent years, 3D printing has become an affordable option for at-home printing and student work. 3D

printers range in scale from small printers created from kits for home or school use to very large printers used in university settings and commercial enterprises.

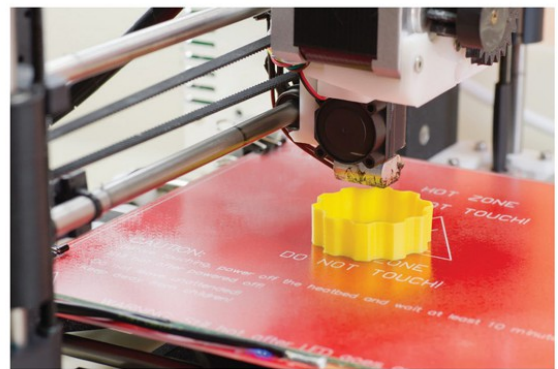
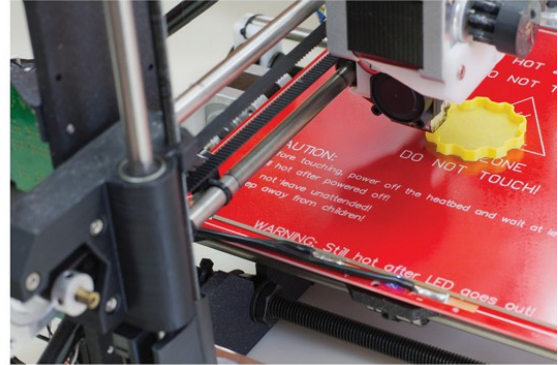

Shutterstock.com/hopsalka

▲ 3D printers create objects through the layering of plastic filament. The printer converts digital information supplied by a CADD program and layers multiple strands of materials to build up a three-dimensional form.

Known as 'additive' printing, 3D printers add layers of a selected material (usually a fibre composite or plastic) over and over to form a three-dimensional representation of a **CADD** drawing. Often used for

prototyping and the construction of models, 3D printing is developing rapidly into a competitive commercial manufacturing process. Clothing, footwear, artworks and products with working parts can be created with 3D printing.

3D printers create forms using an STL file (stereolithography file) that describes the surface geometry of an object created in computer-aided design and drafting (CADD) software. To create the print, the printer builds cross-sections of the object, which correspond to cross-sections in the original STL file.

Like 2D printing methods, the thickness of layers in a three-dimensional print is described in terms of dots per inch (dpi). Typical layer thicknesses are approximately 250 dpi but vary according to the capabilities of the printer. Due to the complexity of the 3D process, printing can take long periods of time, ranging from a few hours to a few days.

## Manual modelling



Katherine Robertson

### Acrylic

If you are fortunate enough to have access to a laser cutter, some models can be made using laser cut acrylic. Acrylic sheet comes in a range of thicknesses and colours and can be cut to create interlocking forms or glued together; it can also be engraved. Due to its properties, it can also be heated and bent to create curved forms. Acrylic is sometimes called 'Perspex', which is the name of a commercial manufacturer.

ISBN 9780170401784

## Hand modelling

Hand modelling of objects is a quick way of creating three-dimensional forms. Commercial modelling or sculpting mediums, including Sculpey and Fimo, can be used to create small forms by hand or with pottery tools. Modelling media come in a range of colours and are often used for character designs for animation and as prototypes for products with a predominantly organic form.

## Paper and card

Papers and lightweight card can be used to construct packaging and small-scale models. There are many packaging templates or flat plans available in books and on the Internet to assist in the construction of common and complex packaging designs. Like a fabric pattern, these templates indicate folds and outlines.

Pasteboard, which is available in a range of thicknesses, is ideal for the representation of packaging concepts.

Other cheap and readily available materials such as strawboard (which is commonly used as a base in architectural models) and lightweight corrugated cardboard can be used to construct models of buildings. The properties of lighter weight, flexible cardboards allow for the depiction of **contours**, curves and details such as ground surfaces, roofs and walls. The scoring of card (by cutting grooves into the material without severing the fibres completely) also allows for effective folds and angles.

## Foamcore

Foamcore is a versatile product that is used in both model making and two-dimensional presentations. It consists of a lightweight foam centre encased on two sides by a paper surface. The foam centre can be brittle if cut incorrectly and should be sliced with a very sharp blade. Use blades only under supervision.

Foamcore is available in several thicknesses and is ideal for models and structures that require solid modelling. Foamcore is also ideal for raising features on a presentation board. It can be placed as a support behind images and text panels to alter the surface of a presentation and draw attention to one or more visual features.

Nelson Visual Communication Design VCE Units 1–4

## Polypropylene

Polypropylene is a firm plastic material that lends itself to packaging. It is available in transparent and semi-opaque colours and is often used in the construction of gift boxes and packaging where visible contents are required. Polypropylene can be scored and folded like card.

## Polystyrene

Polystyrene is a coarse-grained foam-like material that is commonly used in the packing of goods and products for transportation. It crumbles easily when cut with a knife and is best cut with a hot-wire cutter. A smooth, coloured finish can be achieved on polystyrene with the application of water-based paint.

## Styrofoam

Compared to polystyrene, Styrofoam has a finer texture that lends itself to more precise cutting and modelling. It can also be painted with water-based paints for effect. Styrofoam is available in a range of densities and can be cut with a hot-wire cutter.

When cutting Styrofoam or polystyrene you should wear a mask and goggles. Any cutting should be done under supervision in a well-ventilated area.



## Wood

Any sanding or machining of wood and wood products should be done in a controlled, safe and supervised environment. You should always wear a mask when sanding, and if you are required to machine wood, you must wear safety glasses. You should only use power tools under supervision and work in a well-ventilated area.

## Balsa wood

Commonly used in model making, balsa wood is a soft, lightweight material with a fine texture and neutral colour. Flat, square and cylindrical rods of balsa are available and can be sanded, carved or glued to form a variety of shapes. Balsa can be bent slightly and steamed to form lightly curved shapes. Balsa wood can

be brittle, so may need to be combined with a more flexible product such as card. Like many other woods, balsa can be sanded and painted repeatedly to give the appearance of another material such as metal or plastic.

## Medium-density fibreboard (MDF)

Medium-density fibreboard or MDF is made from tightly compressed wood fibres that are bonded into sheets of varying thicknesses. MDF is relatively soft, flexible and does not split; it can be easily shaped with hand tools or machinery. A high-gloss finish that simulates the appearance of moulded plastic is achievable through a laborious but effective process of repeatedly sanding your MDF model and painting it with gloss or automotive enamel.

MDF contains traces of toxic chemicals and should only be sanded, formed and cut in a well-ventilated area. Wear a dust mask.



## Casting

Models that are required to show the form of an object alone can be created with simple casting techniques. After carefully and smoothly forming an object in clay or similar modelling material, a plaster cast can be made and used as the mould for objects to be made with resin, latex or plaster.

## Moulding

Vacuum moulding facilities are not common in schools but offer great opportunities for the development of effective scale models. In vacuum moulding, also known as vacforming, a sheet of plastic is heated to a high temperature, stretched onto a mould, and held against the mould by applying a vacuum between the mould surface and the sheet. This provides a lightweight hollow form. Vacuum moulding is a technique widely used in manufacturing of plastic products.

Injection moulding is a technique where plastics are injected into a mould to form a product. Injection moulding is very commonly used in manufacturing but is uncommon in schools. Sometimes it is possible for student models and prototypes to be created by external providers of these systems.

## Digital modelling

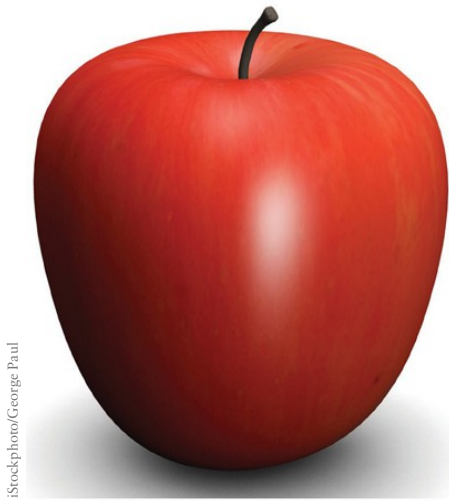

iStockphoto/George Paul

Sometimes it is most efficient to create a digital model of a product or environment. There are many 3D modelling software packages available, including many free ones, that enable designers to create the realistic appearance of a design without the effort or expense of construction.

3D has the capability of using pixels to create the illusion of depth and can reproduce a high degree of realism with as much detail as a live action film. In 3D graphics software, the forms of figures, structures and landscapes are created through complex combinations of shapes formed into a wireframe base. Increasing the number of shapes used to form the wireframe increases the complexity and size of the image. To enhance the realism of the surface of the three-dimensional image, lighting effects, textures and perspective are applied. As in manual rendering, colour and tone are applied to an object to enhance a sense of solidity; the creation of shadow can give objects weight and reinforce the illusion of belonging to a three-dimensional world.

Like other **raster** programs, 3D graphics software often requires the application of an anti-alias function in order to smooth curved areas. Once a wireframe has been created, the program renders the object, modelling the form in a manner that is realistic. With the addition of complex commands that create subtle blurring of movements and realistic reflections and shadows, 3D animation packages can create a sense of fluid motion that emulates rather than exaggerates the natural movements we recognise. In architectural contexts, 3D models are often used to allow viewers to 'fly through' an environment that has not yet been constructed.

ISBN 9780170401784

## DIGITAL DESIGN



There are so many different varieties and versions of digital imaging software available that it isn't possible to discuss the functions of each one in this book.

The two main types of digital design software you are most likely to use are vector-based and raster-based. Many **bitmap** and vector-based programs can be used together to create documents and presentations using both image methods. Examples include Illustrator (vector) and Photoshop (raster).

### IMAGE TYPES

#### Vector images

**Vector** images are mathematically defined images that consist of lines and curves. Formed in programs such as Illustrator or Corel Draw, vector images are sometimes known as object-oriented images. This is due to the ability to move and manipulate entire lines, shapes and curves independently of other image elements. Vector images are not affected by resolution and can be resized with minimal loss of image quality. Common uses for vector images are logos, symbols, illustrations and diagrams.

Nelson Visual Communication Design VCE Units 1–4



▲ Vector illustration of an apple – note no pixellation.

## Raster images

Raster images (also known as bitmap images) use a grid (or raster) of small squares of data known as pixels to create images. The term pixel is based on the words ‘picture’ and ‘element’, and refers to the smallest element of visual information on a computer monitor. Unlike the shapes, lines and curves of vector images, bitmap images can be edited pixel by pixel, or in groups of pixels. Popular pixel-based editing programs are Photoshop and GIMP.

Many bitmap and vector-based programs can be used together to create documents and presentations using both image methods. Software such as InDesign is used to create compositions made up of raster and vector images as well as text. InDesign also has vector capabilities.

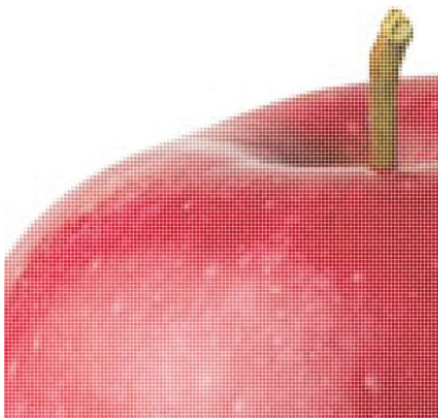

▲ Raster image of an apple – note the pixels that create the image.

## Key ICT facts to remember

### Save your work

Get into the habit of saving your work frequently to save heartache if and when your machine decides to crash. Learn the keyboard shortcut of Ctrl-S on a PC or Command-S on a Mac.

### Name everything

Inevitably, you will build up layers of images, type and effects in your compositions. To make the job of identifying what is what, name all your layers, selections and folders clearly.

### Organise

Many programs offer you the option of creating subfolders of layers, actions, effects and so on. When working with complex images, it pays to get organised by placing all type layers together.

### Backup

It is essential to back up your work. Files can be overwritten and access to a network or hard drive can be lost, so it is important to ensure that you have copies of your work elsewhere. Whether your preferred method for backup is to use cloud storage, an external hard drive or a network drive, just make sure you back up regularly!

### TIP: SAVE CAREFULLY!

Layers, masks, channels and other features of a document are only saved within the software’s proprietary file format, such as a PSD file in Photoshop. If you save your work only as a TIFF or JPEG, the layers are not saved. Until you are certain that your image is complete, continue to save your work in the proprietary format.



## KEY ASPECTS OF DIGITAL IMAGING SOFTWARE

Many popular software programs use very similar tools. The following information is designed to assist you in making the best use of your existing software.

The tools explained here are common to many programs and give an excellent starting point for developing sophisticated digital images.

## Layers

Layers are a function of both bitmap and vector-based software programs. Layers allow images to be placed on transparent virtual sections within a composition. Imagine sheets of clear acetate placed on top of one another and you will start to visualise the concept of layers in digital imaging.

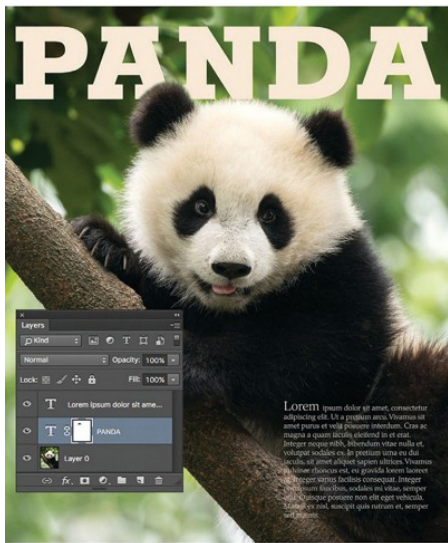

▲ Layers can be used in any design software. In this example, three layers were used to create an image in Photoshop. The first image shows the Layers palette while the diagram explains how the layers could be visualised.

Layers provide flexibility within a composition. Imagery on one layer can be moved, altered or deleted without affecting the rest of the imagery. Parts of a layer can be masked out to blend multiple images together. Type can be added and edited on separate layers.

One of the most beneficial aspects of using layers is the ability to move them above or below other layers. When an image is copied into a composition, it is usually placed on top of existing imagery. By moving the layer, the new imagery can be partially obscured or blended to create apparently seamless combinations of images.

### TIP: USING LAYERS



- 1 Name them.** In some compositions, you will find yourself working with many layers. In order to keep track of what is on each layer, give each layer a distinctive name. Some programs also allow you to colour-code layers.
- 2 Group them.** Some software gives you the opportunity to group layers into layer folders. These can be moved as a whole but edited individually. By using layer groups, you can place related layers together and so avoid listing hundreds of layers on the one palette.
- 3 Merge them.** If layers are no longer required, particularly those with minimal detail, it is a good idea to merge or flatten those layers together to reduce the number. The key is to stay organised.

## Filters

Many software packages offer special effects as an integral aspect of the program. Packages of filters and effects are available and can be added to many software programs. No matter whether you have 10 filters or 1000, they should always be used with caution. Remember, many other people have access to the same tools, so it is up to you to apply them in a unique and creative way.

Filters and effects can be great resources when used in combination with other tools in a program. Simple images and type can benefit from the application of a drop shadow to suggest form. Complex collages of images can be made to appear more realistic with the application of lighting effects, the adjustment of opacity levels and the use of combinations of filters and other tools.

### TIP: USING FILTERS



- 1 **Combine filters.** Many filters offer effects that can be combined with other tools. For example, to create a subtle, soft-focus image, apply a blur tool to a layer below a layer copy of the same image. Adjust the **opacity** of the upper layer for subtle blurring without the loss of image detail. Other filters can be used in this way.
- 2 **Experiment.** Many filters are set with default characteristics. Often a menu will allow you to alter these settings. It is a good idea to use the menu to gauge the effect of each filter by changing the settings rather than using the default settings.

## Selection tools

When working with objects and images, you will often want to make changes and adjustments to one aspect of the composition. Selection tools such as arrows, lassos and wands allow you to select areas of a composition independently of the rest.

Selecting exactly what you want may take practice, and the use of masks and separate layers can make selecting objects much easier. Some tools will select pixels that are similar in colour or tone.

It is possible to specify, by number of pixels, the accuracy of your selection. Selections can be refined with masks. Remember, all good selections take time.

### TIP: USING SELECTION TOOLS



- 1 **A steady hand.** If possible, use a digital tablet and stylus for selection, as this can be a more accurate means of tracing around an area. Remember, be patient!
- 2 **Save them.** After having taken the time to make an accurate selection of an image or object, save the selection. A saved selection can be re-applied at any time; this will save retracing later.
- 3 **Learn them.** There are selection tools for every task, and some are more suitable than others. A wand will be more suitable for a large area of colour whereas a magnetic lasso might be more appropriate for facial details.

## Bezier tools

### QUICKVID: BEZIER TOOLS



Go to <http://www.nelsonnet.com.au> and log in using the code at the back of the book. Go to this title and click on Resources. Go to page 150 to view a helpful video on how to use Bezier tools.

These tools usually look similar to the nib of a pen and they offer some very powerful means of selection and drawing. **Bezier** tools enable you to trace areas of an image or draw irregular shapes and lines accurately. Bezier tools work with a series of lines drawn between anchor points, which can be added and removed as required.

Each anchor point provides the opportunity to reshape and manipulate the lines they are attached to, until an accurate path is created. Bezier lines can bend and twist to form any shape required. This method takes practice but these tools are essential in creating extremely accurate complex selections or paths and tracing line artwork.

Shapes created from the use of the tools can be filled, manipulated and merged to form complex illustrations. Similarly, type can be adjusted, manipulated and re-formed by altering the anchor points.

### TIP: USING BEZIER TOOLS

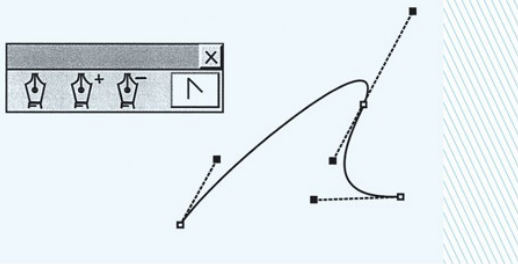

- 1 **Less is more.** Use the minimal number of anchor points when creating a path. Too many anchor points can become confusing and will affect the fluidity of the lines.
- 2 **Work close.** Use the magnifying tools in the software to work close up to your images. The Bezier functions can make subtle changes to your shapes and lines that may not be seen from a zoomed-out perspective.
- 3 **Experiment.** If you haven't used Bezier tools before, they can appear rather intimidating. Once you get started, you'll find that the tools are quite intuitive and simple to use.

## Brooke Nuñez

Illustrator Brooke Nuñez uses Bezier tools in Adobe Illustrator to create her vivid and realistic illustrations. Made up of many, layered shapes, Brooke's designs use hues and tones to create rendered, three-dimensional forms. She works closely with reference materials, using them as a guide to the appearance of each object. Line work is created before colour is added.

A well-organised workspace and the use of clearly labelled layers and folders help to keep a complex process under control. 'Ideally, I like the process to take place over at least a couple of days, giving my eyes a chance to see it freshly a few times. I pick at it and pick at it until I feel nothing more can be either added or taken away.' Brooke Nuñez.





## ANTI-ALIASING

Pixels are squares of digital information, and it can be difficult to create smooth curves or rounded edges with square elements. Consequently, many bitmap software programs feature an option called **anti-alias**. Anti-aliasing creates an illusion of smoothness by adding small graduated areas of colour similar to that of the surrounding pixels. This tricks the eye into seeing pixels that are smooth, and is helpful when applying text in bitmap (raster) programs.

## PREPARING IMAGES

Before using a digital camera or scanner, it is essential to have a clear idea of the end use of the proposed images. Are they to be used as part of a full-colour, printed final presentation? Are they for use online? The end use of the images will dictate the resolution you need and the type of image file required.

## RESOLUTION

The higher the resolution of an image is, the higher the quality. Image resolution is commonly referred to in pixels per inch (ppi), which indicates the number of pixels of information that are represented within an inch of image space. Artwork that will be printed, either professionally or on an inkjet printer, needs to be of a high resolution. For the Visual Communication Design course, a resolution higher than 300 ppi is not generally required for final presentations. An image scanned at 300 ppi can comfortably be enlarged to at least three times its size without losing any sharpness or clarity.

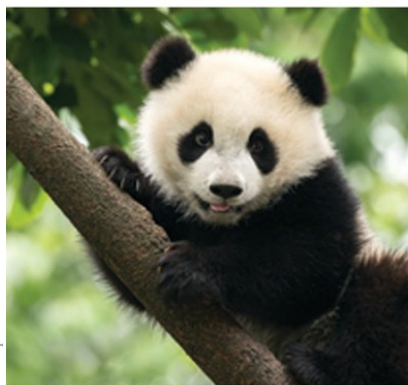

▲ 72 ppi image on-screen

An image created in Photoshop at 300 ppi with an image size of 210 mm × 297 mm, for instance, can be enlarged to 630 mm × 900 mm with minimal loss of quality.

Images that are to be used mainly for Web-based or screen-based purposes, such as webpages and digital presentations, have resolutions of 72 or 75 ppi. Images scanned or created at 72 ppi are not suitable for printing because they lack the sharpness and detail of higher-resolution images. The advantage of low-resolution images, however, is that they are fast to download and view online, or send via email, because of their smaller file size.

## Image size

It is possible to increase image resolution by adjusting image size. If you scan an A4 image (210 mm × 297 mm) at 72 ppi but plan to print it at a size of 70 mm × 100 mm, it is possible to reduce the size and increase the resolution to gain a higher-quality image, suitable for print. This is an important technique to use with digital camera images that are only 72 ppi but very large in actual image size. You can usually use a rule of thirds when resizing images and increasing resolution. Reduce the size of a 72 ppi image by one-third and increase the resolution by one-third. It is best to do this with large JPEG files, however, as small files will not contain enough pixels to work with.

A low-resolution file cannot be changed into a high-resolution file as there are not enough pixels to increase the quality of the image.

In a nutshell, the higher the resolution, the crisper and clearer the image when printed.



▲ 72 ppi image printed



▲ 300 ppi image on-screen



▲ 300 ppi image printed

## IMAGE TYPES

You will come across a number of common image types in your study of Visual Communication

Design. Each of the types has one or more distinct applications. Your choice of image type will be determined by the intended use of the image itself.

Image type	Use	Description
<b>TIFF</b> Tagged Image File Format	Print	This is one of the main formats for preparing graphics for print and publication. TIFF files retain the maximum amount of visual information and consequently maintain a large file size.
<b>JPEG</b> Joint Photographic Experts Group	Web (and print if high quality)	A popular Web graphics format. Although JPEG files are compressed (which causes some loss of quality) they are a good format for high-quality images that need to be emailed or published electronically. JPEG files are often smaller in size and this can be adjusted by altering the quality in a program such as Photoshop.
<b>GIF</b> Graphics Interchange Format	Web	A standard format for Web graphics such as icons, toolbars and <b>thumbnail</b> images. GIF files contain minimal visual information and exist in a highly compressed format so their file size is very small.
<b>EPS</b> Encapsulated PostScript	Print	A <b>file type</b> preferred by commercial printing companies that print publications on very high-resolution printers. PostScript is a vector language used in publishing software such as InDesign, and it treats all images, including fonts, as objects rather than bitmaps.
<b>PDF</b> Portable Document Format	Print and Web	A proprietary Adobe format that is created and/or read in Adobe Acrobat. A PDF file enables a document to be compressed, sent, viewed and printed electronically without any loss of the original format, fonts or graphics. Many commercial printers prefer files submitted as PDF format.
<b>BMP</b> Bitmap	Print and Web	A file format for saving high-quality bitmap images, originally designed for Microsoft Windows systems. A BMP file is similar in type and file size to a TIFF.
<b>PNG</b> Portable Network Graphic	Print and Web	A file format popular for online use. Often has a transparent background.
Proprietary file types	Print and Web	All graphics software programs use their own proprietary file formats. In Photoshop, the default file format is PSD, which allows you to keep all layers, selections and channels intact. Illustrator uses the default file format AI; CAD uses DWG and so on. A good tip is to always save a version of your work in the proprietary format so that you can return to it at a later stage and make any necessary changes.

## COLOUR MANAGEMENT

There are several colour modes that apply to digital images and, as with resolution, it is helpful to know the purpose of the artwork in order to identify the most appropriate mode of colour.

### CMYK: Cyan Magenta Yellow Black

If you are creating images and presentations for commercial print production, you will need to save your images in CMYK mode.

Many home inkjet printers also use four separate ink cartridges to produce image colour. RGB images can be converted to CMYK but some colour change is likely to occur. CMYK is a subtractive colour mode and is also referred to as four colour and process colour.

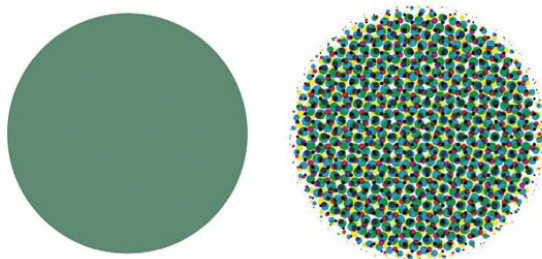

- ▲ This green circle will be printed as CMYK in the following percentages: 67% Cyan, 28% Magenta, 57% Yellow and 11% Black. A colour halftone enables us to see how the colours will be distributed during the CMYK printing process.

### RGB: Red Green Blue

RGB colour is used for screen and digital designs where professional printing is not the desired final outcome. Varying amounts of red, green and blue light create RGB colour. RGB mode is used on digital devices such as computer monitors, laptops and mobile devices. RGB is an additive colour mode.

### Web-safe colours

RGB colours are considered 'Web safe'. This means that colours used on a website (or other presentation designed for viewing on a computer monitor) are guaranteed to appear as intended.

As computer users have monitors adjusted to different colour settings, the Web-safe colours

provide for the most basic setting. You can use a myriad of RGB colour combinations, but there is no guarantee that every user will view them in the same way, due to differences in device quality. Each of the Web-safe colours is identified by a hexadecimal code; for example, a bright red may have an RGB value of R255 G0 B0 and a hexadecimal code of #FF0000. This code is used in Hypertext Markup Language (HTML), the code used to create Web content, to identify colour.

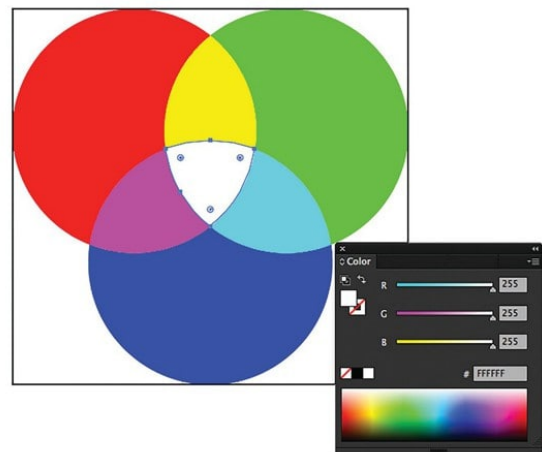

- ▲ In your chosen editing program, you can track the values of both additive and subtractive colour modes. In this example, white is created by the maximum values of red, green and blue: R255, G255 and B255.

### Making the right choices

As mentioned earlier, it is important to know the context in which your digital work will be used, so that you can plan ahead. There is nothing worse than spending hours on an image, only to find that the resolution is not good enough to print or that your colour mode is incorrect.

Be aware of image sizes when downloading images from the Internet to use in your design work. Make sure they are large enough to print them if you wish to. It is possible to adjust your image search to 'large' to find images of better quality. When downloading images, remember to attribute the source of your images (see Chapter 13 for information about copyright).

Planned use*	Suggested resolution	Suggested colour mode	Suggested file format
Artwork for full-colour printing	300+ ppi	CMYK or PMS/Spot colours	TIFF, EPS or PDF (or large, high-quality JPEG)
Black and white for printing	150+ ppi	Greyscale	TIFF, EPS or PDF (or large, high-quality JPEG)
Simple Web graphics such as icons and buttons	72–75 ppi	Indexed colour or RGB	GIF or PNG
Detailed, photo-realistic graphics such as large images for use on the Internet	72–75 ppi	RGB	JPEG or PNG
Graphics for digital presentations such as PowerPoint, Prezi, etc.	72 ppi	RGB	JPEG

\*If you plan to have your design commercially printed, check with the printer or read their guidelines for artwork, to be sure of the appropriate file type.

## PHOTOGRAPHY



Photography is used extensively in visual communications. Advertising, in particular, makes more use of photography than any other media. Photography allows us to see a certain reality by recognisable visual means.

In Visual Communication Design, a camera can be used to record your research and images that may form the basis of drawings from observation. The progress of a three-dimensional design concept can be easily recorded and documented by successive

photographs. Importantly, photography can form the most significant part of your final presentation, displaying your design concept as the feature of your composition.

The digital camera is the most popular photographic tool but if you are fortunate enough to have access to a darkroom, and the skills and time to process and develop your own film, you may choose to apply traditional photographic skills in your work. If not, it is possible to recreate darkroom techniques using digital means.

Photo manipulation software was originally designed as a computer-based darkroom. Many of the tools offered by these software programs were developed from manual tools used by film photographers. Digital photography and associated software provide designers with new and remarkable techniques, but the fundamental principles of photo enhancement remain unchanged.

### TIPS FOR TAKING GOOD PHOTOGRAPHS

Something else that remains unchanged is the fact that a good photograph – one that is carefully composed and exposed correctly (whether on film or digitally) – is absolutely essential to the end result. A poorly exposed or badly composed image may be improved using computer techniques but will never give the best results. Life is made easier if you start with the best possible image.



Goldie Cromb

- ▲ This student used photography as an integral part of her identity design for a brand of surf wax. She took her own photographs, planning to take them at dawn when the light was most appealing for her design. She then edited them using Photoshop and the final design was created using InDesign.

## Plan

It is important to know the purpose of the photograph before you take it. Will it be a feature of your presentation? Will it be a background image? Understanding how the photograph is to be used will assist you in composing the image.

## Compose

Think carefully about what needs to be included in your photograph. Where is the focal point? What is the best shape or proportion to suit your image? Consider the entire frame of the film: should it be filled with detail or contain space? Should part of the image be closely cropped or included in the frame? Will the image be more effective as a vertical or horizontal composition?

If working with a model or still life, rather than incidental or action images, it is wise to sketch ideas in your workbook before proceeding with the photo shoot.

## Lighting

Lighting is perhaps the most influential factor in your photography. Lighting will determine the quality of the

image. Again, the purpose of your photography needs to be clear, as this will help you to determine what lighting will best suit your ideas.

Available light refers to daylight or interior lighting, and taking photographs in available light assists in capturing the atmosphere and reality of an environment. Keep in mind that colour film used under fluorescent lighting will develop with a blue hue, while the same film used under household light (incandescent globes) will develop with a gold–yellow hue. Adjustments can be made in photo manipulation software to compensate for this.

Studio lighting can be set up using professional quality lights and reflectors, or simply with lamps and white cardboard. Be creative with the use of available resources and don't be discouraged if you don't have access to professional quality products – improvise!

The placement of lighting will influence the quality of the light. Shadows and highlights will be affected by the proximity and placement of the light source (or sources). Soft lighting can be achieved by 'bouncing' light from a reflector or a piece of white cardboard. Casting strong light directly onto the subject can create harsher and more dramatic lighting effects through the creation of strong shadow. Experiment with the placement of your lights to achieve the desired result.



Constantine Virtanen

- ▲ Combining his passion for photography and love of music, this student created album artwork for part of his SAT Folio. Using a very basic lighting setup of two spotlights and a white background he was able to ensure consistent exposures for his images. Background colours were changed using Photoshop.

**TIP: EXPOSE FOR THE SHADOWS**

Use either a handheld light meter or your camera's inbuilt light meter to take readings from several areas of the image. 'Expose for the shadows' and be sure to take a reading that accounts for details in the darkest areas of the subject.

## THE CAMERA

Cameras are available in a wide range of types and models. Digital cameras include single-lens reflex (SLR) cameras, compact cameras and mobile phones. Film cameras include SLRs, instant cameras and Lomo or toy cameras. It is important to understand how your camera works.

Digital cameras use electrical charges to transfer an image to a digital storage device. Film cameras use film that is treated with a light-sensitive emulsion to capture images.

### Camera types

#### Digital camera

A digital camera converts light into electrical impulses and records an image onto a data storage device such as a memory card. The memory card is then transferred to a computer or printer via a high-speed connection or reading device. Digital cameras are offered in an extensive range of compact or SLR bodies.

#### SLR camera

A single-lens reflex camera often has both manual and fully automatic exposure functions, so that settings may be adjusted to suit a specific purpose. SLR cameras allow the photographer to see exactly the same image that is exposed to the memory card or film. Lenses – from telephoto to wide angle – are interchangeable on the SLR camera, making it suitable for all types of photography, from portraiture to landscapes. SLR cameras are available for digital media. Many professional and amateur photographers use film-based SLRs for their work, as the qualities are quite different to digital means. Use a negative/film scanner to edit film images digitally.

#### Compact camera

Compact cameras are usually fully automatic, with all functions controlled by a central microprocessor that receives information from an auto-focus system and light meter. Unlike the SLR, a compact camera does not provide an exact preview of the image that will be exposed.

#### Instant camera

Invented by Edwin Land in 1947 and developed by Polaroid, instant cameras provide the ability to process film immediately after taking a photograph. Chemicals embedded in instant film begin to develop when pressed together by rollers within the instant camera. Although the image has formed in the multiple ink and chemical layers within the film, the final layer develops last and the image seems to appear before our eyes.

When an instant photo develops, it takes some time for the developer dye to dry completely. It is possible to manipulate images by spreading the dye around the surface of the print with a pencil or cotton tip; another option is to press the wet photo paper to make a print. Some photographers still use instant film to preview a composition. Many amateur photographers enjoy the retro qualities of instant film and similar effects can be gained with apps or software.

#### Lomo and toy cameras

Lomo is the commercial name of an Austrian optical company whose cameras are renowned as playful and fun. Lomo has become the term used to describe an alternative type of photography that features imperfect exposures and over-saturated colours. Similarly, toy cameras such as the 'Diana' are tools for photographic experimentation that use 35 mm or 120 mm film. They are popular with experimental photographers who enjoy distinctive features such as 'light leaks' and double exposures.

#### Mobile phone cameras

The sophistication of mobile phone cameras is at times equal to a small compact camera and offers many creative applications. There are a variety of photographic apps available that recreate the qualities of other cameras (including toy, Lomo and

Polaroid cameras) on mobile phone cameras. Mobile phone cameras can also be useful for capturing inspiration images and quick snapshots of ideas to use in your folio.

## RAW! WHAT IS IT GOOD FOR?

FYI

Digital SLR cameras will provide an option to shoot in RAW format or JPEG format. JPEG images are processed by the camera while RAW files are left untouched. RAW files are therefore much larger and contain all of the visual data from the original image. JPEG files are a 'lossy' format so some data is stripped during compression by the DSLR. RAW files are processed by computer and can be edited in specialist software such as Adobe Lightroom, (although Photoshop also features some tools for RAW files). For further editing in Photoshop, sharing, printing and publication, they need to be converted to another format such as a JPEG or TIFF. Whether you shoot in RAW or JPEG is a matter of how particular you are about the clarity of image and whether you have access to the appropriate software. With the right exposure and settings, high-quality JPEG images are also achievable with a digital SLR.

## CHAPTER RECAP



- 1 What are the appropriate colour mode, resolution and file type for the following images?
  - + An image of a small product to be sold in an online store.
  - + A logo to be applied to a range of merchandise including packaging and posters.
  - + A headshot of a designer to be used in a digital presentation about design processes.
- 2 What is the name for the tools that manipulate anchor points?
- 3 What is the professional term used to describe paper types?
- 4 Investigate and illustrate the difference between additive and subtractive colours.
- 5 Find examples of collage, pencil drawing, watercolour and screenprinting used in contemporary visual communications.



PART B

# DESIGN PROCESSES



# DESIGN PROCESS

CHAPTER

8

## In this chapter:

+ The design brief .....	161
» The design problem .....	162
» The client .....	162
» The audience .....	162
» Context of the design .....	163
» The purpose .....	163
» Constraints .....	163
+ Research .....	164
» Research types .....	167
» Collecting research .....	170
» Research resources .....	171
» Organising and interpreting research .....	174
+ Generating ideas .....	175
» Annotating your design ideas .....	177
» Drawing to generate ideas .....	178
+ Developing concepts .....	184
+ Refinement .....	191
» Mock-ups and prototypes .....	195
+ Evaluation .....	197
+ Resolution and production .....	201
+ A pitch as an evaluation technique .....	203
» Key elements of a pitch .....	203

## Learn the language

annotation	client	evaluation	refinement
audience/user	constraint	mock-up	visualisation

You will find helpful tasks related to design processes in Part D and throughout *Nelson Visual Communication Design VCE Units 1–4 Workbook, Edition Three*.

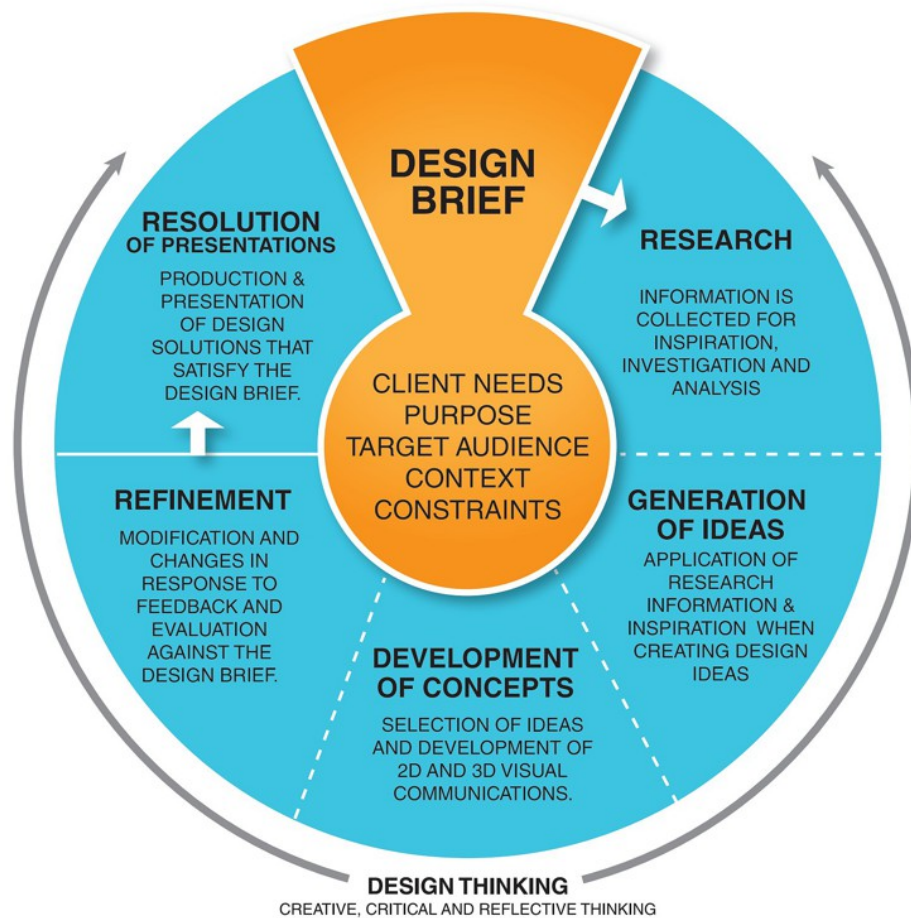

In the production of visual communications, a design process is usually applied. The design process involves stages of concept development and production, initiated and inspired by a design brief.

The design process is a cycle. The cycle begins with the design brief, which identifies the communication need. Information such as target audience, purpose and constraints are identified in the brief. Moving through the cyclical process, research identifies further information and data, which focuses the direction of the visual communication.

Throughout the design process there is scope for imagination and creative risk taking. The process allows for freedom and flexibility within the framework of the brief, and encourages experimentation with ideas, materials, media, methods, design elements and design principles. Constant evaluation is an essential part of

the process. It is through this process of inspiration, experimentation, evaluation and elimination that effective visual communications evolve.

## THE DESIGN BRIEF

- + Describes the design problem – the need of the client and deliverables.
- + Provides information about the initiator – the **client**.
- + Describes who the product is to be directed at – the **audience**.
- + Explains how the product will be used – the purpose and **context**.
- + Identifies **constraints** and limitations.

The design brief is the starting point of the design process, and might be a detailed written document,

or a verbal or even visual explanation of the design problem that requires an effective visual solution.

## THE DESIGN PROBLEM

A design problem is an identified need that requires a designed solution. Design problems can range in scale from the small, such as a brochure design for a small, gourmet grocery store, to the very, very large, such as the design of an Olympic stadium.

## THE CLIENT

In a professional design environment, a client may approach a designer or design firm with a design problem because they were recommended to the client, or because the client was interested in work previously completed by that designer or firm. Initial meetings take place to establish what the client sees as the design problem. At this stage, both client and designer can judge whether a suitable working relationship is likely. Some designers specialise in particular fields, so it is important to determine at an early stage whether the client's requirements and the designer's expertise are a match.

Clients may have a limited knowledge of the design process so the initial communication may facilitate discussions about cost, timing and possible design outcomes. At this point, a detailed written brief is developed. The brief identifies important details such as the audience or market, the design criteria, the function of the final design, any constraints – such as cost, timing – and the 'deliverables' or final outcomes required of the final design.

Some designers use a 'return brief' in the early stages of a project. Taking the information gathered from the client, the designer writes the brief as they interpret it and then asks the client for comment. This technique allows the designer to craft a brief from a design perspective; returning it to the client ensures that both parties have a clear understanding of the final design deliverables.

## THE AUDIENCE

The audience is the market or target group to whom the visual communication will be directed. The client will often have a clear idea of the market but may be

seeking to expand it or attract a new audience to a product or service. The designer's task is to identify the specific characteristics of the target group. Any special characteristics of this group will affect how the visual communication is developed.

Audience characteristics are often divided into specific types of data such as age, gender, socioeconomic status and interests. Other factors such as location, cultural background and religious affiliation can also affect the content, appearance and message of a visual communication.

(For more detailed information about audiences of visual communications – see Chapter 10.)

### Age

Age can be identified in very specific terms or more broadly, and is often classified by arrangement into groupings. For example, 18–25 years might be more loosely defined as young adults, 40–55 years might be classified as middle-aged adults, and so on. Terms such as Baby Boomers, Generation X or Y and Millennials, used by marketers to establish generational groupings, are somewhat helpful but can be overly broad categorisations.

### Gender

Visual communications can be targeted at a male or female audience or may be gender non-specific. The influence of gender is very strong in defining personality traits and consumer preferences, and will dictate the use of many design elements and principles in a visual communication.

### Socioeconomic status

This usually refers to the financial and social position of an audience. In Australia we perceive ourselves to be an egalitarian society and have little interest in a 'class' structure. Rather than defining social groups as working class, middle class and so on, we tend to identify ourselves by our level of financial income. Employment status, salary level and educational background can be factors in identifying the socioeconomic status of an individual or group. The amount of money people earn determines their 'disposable' or discretionary income (that is, the income remaining after essentials are covered). Groups with a high disposable income are attractive to marketers.

## Interests

This is a vast category of great importance to designers and market researchers. The interests of a specific audience may include music and fashion, for example, but there exist subcategories of those interests that can define an audience in even more detail. The specific style of music and the fashion labels that are preferred by an audience will influence their habits as consumers.

Interests may also refer to specific professional or personal interests. A visual communication may be targeted at small associations of professionals such as surgeons, carpenters or chemical engineers, or at an organisation based on shared interests, such as the Veteran Car Club or the Victorian Surfriders Association.

## Cultural background

The content of a visual communication may be influenced by the belief system of the audience. The appropriateness of imagery and content will be defined by cultural and religious traditions. If a brief addresses the needs of a culturally specific audience, it is essential that the designer has an understanding of what visual material is and is not appropriate to use.

## Location

Where an audience lives can have an impact on the effectiveness of visual communications. A target audience in a remote area will have different opportunities to view visual communications compared with an audience in an urban location. Visual communications may also be quite specific to a region or area. Location can also affect the socioeconomic status of an audience, as some areas offer different opportunities for employment or professional advancement. Location can also affect the language used in a visual communication, the appropriateness of colour and images, and the scale or proportions of the design. An environmental design is affected by its location; the use of materials and the appearance of the structure may be impacted by geographical and planning boundaries.

## CONTEXT OF THE DESIGN

Where a design will be used has a major impact on the content, appearance, materials and format. The physical location will determine scale, materials

and the design elements and principles to be used. A billboard displayed at the edge of a freeway, for example, will be viewed by drivers and passengers passing by at 100 kilometres per hour. The content will be read from a distance, so a design that is heavily dependent on text and small detail would clearly not be suitable.

Design products found in magazines and journals are tailored to suit the purchasers of the publications. A fashion magazine features quite different advertising content to a magazine about cars or aviation. The content of the magazine itself may dictate how the visual communication should appear. Architecture and design magazines often use large areas of white space and apply fashionable design methods such as line illustrations and a sans serif typeface. Magazines directed at young people interested in surfing or skating may contain page layouts that are action-packed, with large photographs and contrasting typefaces.

## THE PURPOSE

All visual communication has a purpose, and that purpose has a major impact on the content and appearance of the visual communication. It will define the content of the visual communication and establish where and how the visual communication will be seen, who will see it, and how often.

The purpose of a visual communication might be to advertise, promote, depict, teach, inform, explain and/or guide. Often, a visual communication will have more than one purpose, but it is usually possible to identify these as the primary purpose and additional, secondary purposes. For instance, a poster advertising a music festival may include the date and time, ticket prices and booking information, along with a map of the location to guide the attendees. The primary purpose of the poster is to advertise the music festival and sell tickets, but the other purposes can be equally important.

(For more detailed information about the purposes of visual communications – see Chapter 4.)

## CONSTRAINTS

Constraints can have a considerable impact on the outcome of a design brief and it is important to identify them as early as possible in the design

process. During the initial meetings between client and designer, the possible restrictions on the project are identified. These include:

- + time
- + cost
- + location
- + materials and technologies.

Common constraints such as time and cost have a major impact on the design outcomes. A large project requires a longer time frame and usually needs a bigger budget, so a clear understanding of the cost and time frame must be established in the early stages of the client–designer relationship. The location of a design task can also provide challenges; in a global marketplace, many designers find themselves working in overseas locations, where language and cultural differences can affect the flow of a design process. The scale of a design task and the materials required may also be factors in determining the success of a final design. If a designer is unfamiliar with new materials, technologies and processes, then training and education must be addressed.

## RESEARCH

Research is essential and provides important information about current trends, the work of other designers, and essential information about the preferences of the target audience.

Observation and investigation are key methods of research. An architect will visit the site of a building to study the location of the structure and the surrounding environment. A graphic designer may meet with members of the target audience to gather first-hand information about trends, fashion and attitudes. An industrial designer may research how a consumer uses a product. Many designers will investigate existing products and designs in the marketplace for inspiration and an understanding of where a new product might be positioned.

To gain very specific information about the target audience, designers may use market research companies.

Small groups of people who fit within the target audience range are observed during discussions or asked specific questions about their tastes and responses to existing products. Trend-forecasting firms also offer vast amounts of information about future developments in colour, styling, product forms and fashion.

## MARKET RESEARCH

ACCORDING TO THE AUDIENCE // SURVEY

THE FACT THAT A CAFE SERVED ONLY FAIR-TRADE COFFEE AND LOCALLY GROWN FOOD WOULD INFLUENCE MY DECISION TO GO THERE:

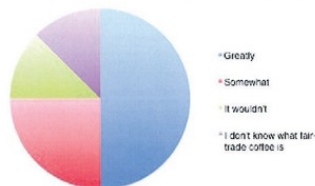

By surveying both males and females, allowed me to compare their preferences and see the similarities and differences between the personal choices of sexes. More females preferred home-style design of cafes, where males preferred industrial. Women also preferred a warm and cosy cafe, where as males preferred a trendy and popular cafe. By seeing the difference between sexes has allowed to see what I need to include in my design to attract both males and females.

WHAT TYPE OF ATMOSPHERE DO YOU PREFER IN A CAFE?

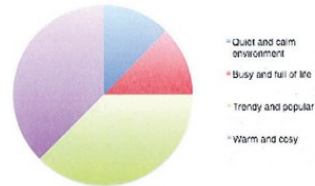

By using surveys to source information from the target audience, I have discovered peoples personal preferences and priorities in a cafe. By asking what their favourite cafe was, allowed me to do research into the style of the cafe, where it was located and the general aesthetic of the design. I was able to research into how location plays a role in enticing customers and how the main feel and mood of the cafe will affect the type of audience that you attract. By also asking what people generally order at a cafe, has taught me why people go to cafes and how much food and drinks they consume when dining out. By asking how much they roughly buy, gave me a rough estimate at the amount of time spent they may spend in a cafe.

WHAT STYLE OF INTERIOR DESIGN DO YOU PREFER?

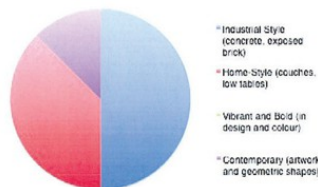

When asked how important atmosphere was when choosing a cafe, a majority of the participants rated it very highly, which shows me the aesthetic of a cafe is the most important factor when deciding on a cafe. The design of the cafe was rated quite important to the audience as well. For the customers to enjoy their experience in a cafe, means they need to be comfortable in their environment and feel relaxed. Many participants saw the design and the atmosphere of the cafe as the most important qualities in a cafe. The least quality they found important was the quality of the coffee.

Meg Jamieson

- ▲ This student undertook her own market research in designing the interior of a cafe. She undertook surveys and then organised her data visually to help direct her initial design ideas.

# EXISTING PRODUCTS

These images illustrate the convenience of the stapler.

Interesting form but looks a bit bulky

Quite a big stapler, judging from the proportion of the photo

Similar form, only the lever is at the bottom

Stand stably. Easy to use: just push down, don't have to pick the stapler up

Colour pink: more attractive to female students/office workers

Key chain → portable prevent loss

Fits in a pencil case/ an office toolbox

Generally rectangular in form, with curved edges

Simple and elegant design

Vertical stapling: The slit is at the top, push these 'buttons' on the sides

Creative form; however the all-metal surface makes it look plain, cold & heavy

Make the 'button' a bit more cylindrical; incline the top

Cube: very streamlined & balanced

The slit could curve up like this

This design appears to be modern & professional thanks to colours (black & white) and the curved shape of the base

Transparent plastic allows the user to see the components inside, making the audience want to look carefully to see how it works

Vintage design: every component looks thick & solid; smooth metallic surface. Thanks to the ruler placed beside the stapler we know it is, not as big as it looks.

Bright colours

The plastic looks cheap, so the stapler seems to be low quality & not very attractive

From this:

Another vintage design:

Strong, firm, solid but not very suitable for modern office environment looks like it can handle heavier duty than 6 sheets of paper

The shapes of the base and handle are very creative

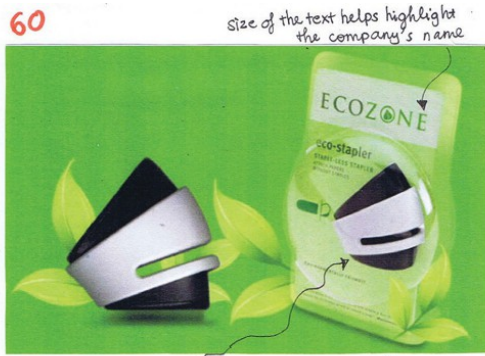

60 size of the text helps highlight the company's name

The black & white stapler stands out against the light green packaging

This design is very eye-catching because it gives a strong sense of modernity & freshness

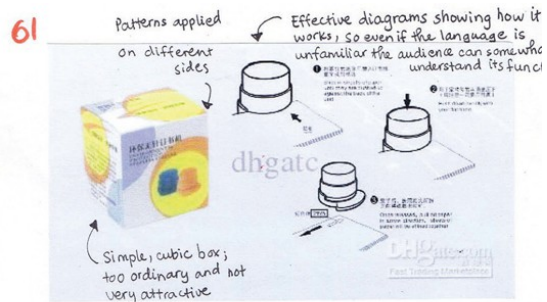

61 Patterns applied on different sides

Effective diagrams showing how it works, so even if the language is unfamiliar the audience can somewhat understand its function

Simple, cubic box; too ordinary and not very attractive



An ineffective design: everything's green, so nothing really stands out except for this line in red, which is unnecessary as it only briefly describes what the product is

Key information is not highlighted

# FIELD TRIP

I VISITED AN OFFICE SUPPLIES RETAIL STORE TO FIND OUT ABOUT VARIOUS PACKAGING ON DISPLAY.

THESE ARE TRADITIONAL STAPLERS BUT I THINK STUDYING THE PACKAGING WOULD HELP, SINCE BOTH TYPES HAVE SIMILAR FUNCTIONS



63

Colour of the graphic matches colour of the stapler



64

Images add to the aesthetic of the packaging

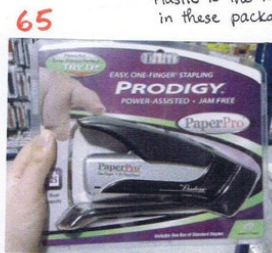

65

Plastic is the main material used in these packaging



66

These staplers are power-assisted so they look quite bulky, and the colour purple emphasises a sense of power.



67

The vivid yellow colour and larger logo make this packaging more eye-catching than the J. Burrows ones



68

Product is visible through this piece of plastic

Bigger & stronger boxes

The staple (figure) stands out against the green ground



69

The white space makes the eyes focus on this image photo first



70

Nhu Duong

▲ In researching a new stapler design, this student looked at existing products in the marketplace, she looked at products around her, products online and took a field trip.

The collected research data is analysed carefully to establish the accuracy of the information and its value to the brief. The verification of research is very important as styles and trends can change quickly, relegating what was once thought to be innovative to the out-of-date bin. Fashion design, advertising and graphic design are particularly susceptible to changes in public attitudes and fashion trends.

Research might continue throughout the design process. A design brief can demand more than one deliverable. For example, the main design brief may be for the design of a corporate logo but the brief may also require that the logo be used in a wide range of applications. These applications may include vehicles, clothing, stationery and advertising. The designer, in this scenario, would need to undertake research into the best means of applying the logo to these diverse carriers.

Research can include:

- + investigation of the client history and existing products or services
- + investigation of direct competition to a new product or service
- + observation of the target audience in order to understand trends and preferences
- + observation of the location or context of the final design
- + analysis of data about future trends, new materials, community attitudes
- + collection of visual information to inspire new concepts.

Research is an integral part of the design process. Research provides a window to essential information about important aspects of the brief, such as the audience and the relevant historical background to the task. Researching all aspects of the design brief is an important undertaking. Knowing about the client and their design history can help to ensure a new design is original and not repetitive. Research of the target audience helps to identify interests, preferences and trends. Research of similar design products is important to establish a point of difference and to view competitors' products.

Gathering inspirational material is also an important function of research. Inspiration may come from anywhere and anything. Many designers find inspiration in random 'found objects', colours, words, textures, landscapes and intangible experiences such

as events, interactions and moods. Be open-minded and aware that inspirational material is all around you and may capture your interest and creativity at any time! Be prepared to collect items that might inspire the form, function or appearance of a design product.

Research is valuable for concept inspiration and it is essential to a response to a brief. How thoroughly you understand the design problem will direct the success of your final design concepts.

## RESEARCH TYPES

### Quantitative and qualitative research

In the discussion of research there are two common categories into which most research will fall: quantitative and qualitative research. The key to the difference between each category is in the name.

#### Quantitative research

Quantitative research is concerned with statistical data and measurable, objective information. For example, quantitative information may be gathered by a web designer who is interested in establishing the success of interactive elements on a website. Gathering data related to the number of times users click on Web elements may assist the designer in creating appealing and successful online content.

#### Qualitative research

Qualitative research is **subjective** and deals, in many cases, with images, words and behaviours. Qualitative research methods include interviews and observations. For example, in the design of a children's playground, the designer may apply qualitative research by observing and documenting the behaviour of young children at play. Using the observations noted, the designer may be able to establish patterns and commonalities to assist in designing the most appropriate and engaging playground.

It is likely that you will apply predominantly qualitative research methods to your design work but it is also very help to use quantitative methods when gathering factual data to inform your design concepts.



## INSPIRATIONAL MATERIAL: RELEVANT PATTERN + FORM IN URBAN ENVIRONMENTS.

I figured it was important to explore the environment that my target audience work/live in, as many people draw inspiration from this. My original intention was to collect a few sample shots that could be used in my research and development, however I ended up spending a whole day continuously finding countless forms and patterns in my surroundings. I believe using this association with environment and workplace has the potential to strengthen my product and make it more appealing to my audience.

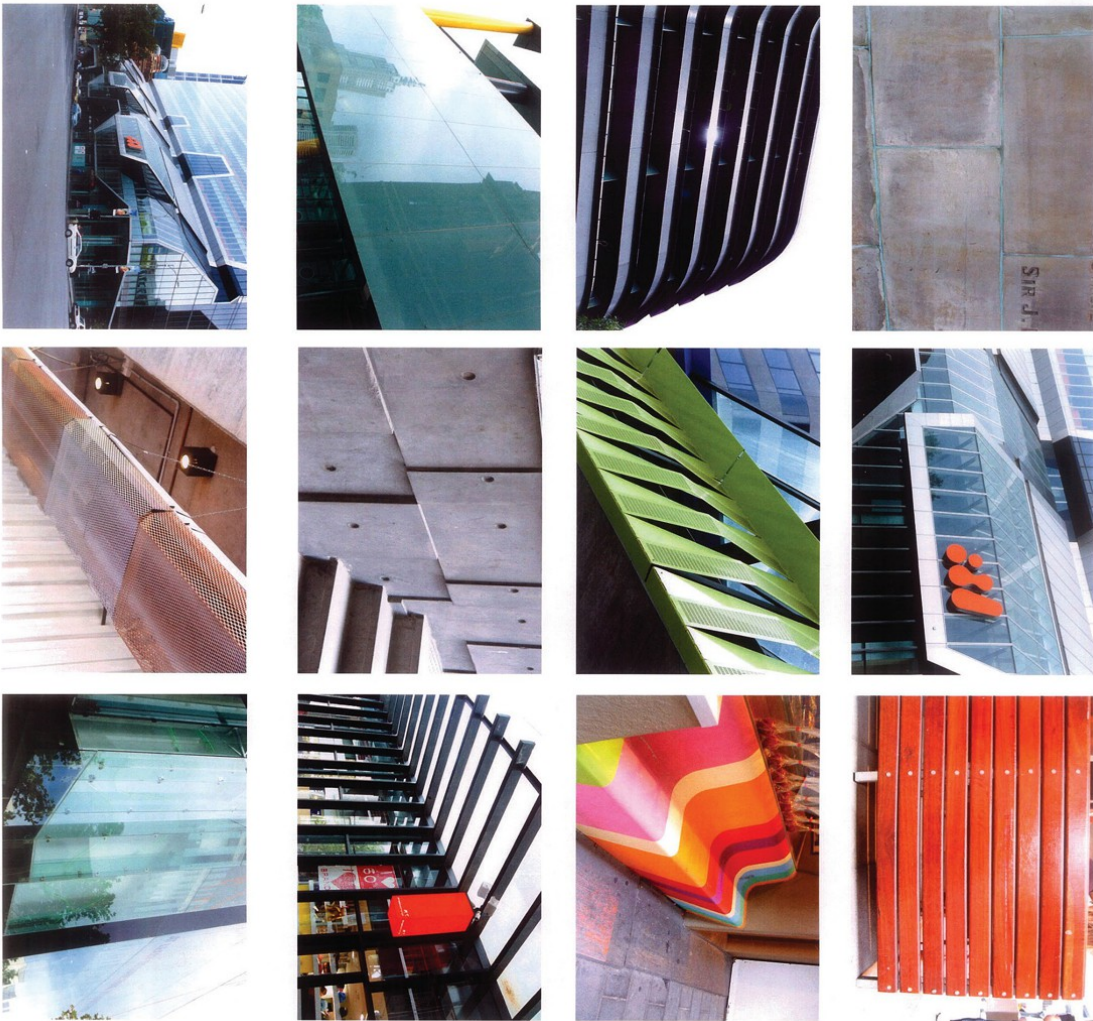

Ben Jennings

▲ This student took photographs of patterns, forms, shapes and structures that inspired him. He later used the images to initiate design ideas for product forms and surface patterns.

▼ Examples of quantitative and qualitative data

Quantitative	Qualitative
The company has eight employees.	The company is small.
The house has four bedrooms.	The house is spacious.
She is 178.5 cm in height.	She is tall.
The document contains 150 words.	The document is brief.

▼ Methods of quantitative and qualitative research

Quantitative	Qualitative
Surveys	Observations
Data	Interviews
Measurements	Market research

## Primary and secondary research

Primary research and secondary research refer to the source of research materials. Primary research involves collecting information specifically for a design brief. It is gathered from original sources through

▼ Examples of primary and secondary research

Primary	Secondary
Interviews with members of the target audience.	Review of articles describing the characteristics of the target audience.
Photographs and collage images of objects related to the design brief.	Use of stock photography images related to the design brief.
A focus group of users to discuss how effectively a design functions.	Use of census or similar data.

### MARKET RESEARCH ACCORDING TO THE INDUSTRY

Dr Kendall Cook looks into the importance of album artwork and the impact it has on consumers, the music industry and the artist itself. Dr Kendall Cook discusses how album artwork has integrated into the 21st century and its adaptation to the new music formats.

*Music Industry Market Research: The Effect of Cover Artwork on the Music Industry*  
 Presented by Kendall Cook  
 Graphic Communication Department  
 California Polytechnic State University 2013  
<http://linquist.com/pl22078>

Cover art grabs the attention of the consumer and is their first impression of the album. Visual artwork is powerful, and just as a book cover grabs the attention of the reader, album artwork grabs the attention of the listener. Music sales have experienced negative and positive influences. The development of music videos, online stores such as Apple's iTunes and Spotify, cover art, and media organizers/players have grabbed the consumer's interest and have created new methods of promoting music sales.

Cover Artwork is an area of the music industry that has not yet been explored is the connection the consumer has with the aesthetics of album art. Tangible products such as records, cassettes, and CDs, all had album artwork. When a consumer picks up one of these products, cover art was the first noticeable characteristic. Holding something that is visual brings an associated connection with the album and the artist. Album artwork is very similar to branding logos. When a music user sees album artwork they immediately know which artist produced the album. This phenomenon created by artists and record label companies, was one of the best and most effective marketing strategies of that time. Cover art is an expression that represents the artist. It has symbolism and colors that one can identify with that particular artist or album that is produced. Just as book covers grab the attention of the reader, cover art grabs the attention of the listener.

Album packaging grew in importance as time went on, record companies added gatefolds, lyric pages, sticker inserts, extra sleeves, poster inserts, etc. as a way to gain the customer's interest. Many of the additional features added to the record packaging, gave the listener a deeper insight about the artist. By creating a culture around the artist, consumer interest grew, and customers not only wanted to listen to the music, but also collect the memorabilia. Rock Stars lived glamorized lifestyles that were fabricated by record sales companies to make money by inspiring dreams of the youthful generation. By creating this culture, record companies weren't just selling records; they were also selling clothes, films, musical instruments, and other commercial products.

Art is powerful and though digital sales contain artwork they are not as noticeable as a tangible product. When holding a record, cassette, or a CD, cover art is the first thing a consumer sees. A digital track has the artwork embedded into the file that shows up on media devices that play the music, but it is no longer the outwardly noticeable characteristic it once was. Users no longer associate a connection between the album and artwork, because individual tracks are purchased.

DIGITAL FORMATS OF ALBUMS ARE HARDER TO IMMUNATE A VISUAL IDENTITY FOR ANY GIVEN THE ARTIST'S STYLE & VISUAL REPRESENTATION, BUT ADD THE VISUALIZATION OF THEIR SOUND.

MUST BE EYE CATCHING EVEN AS A MP3 FORMAT  
 - BOLD  
 - SLEEK  
 - SIMPLE

MP3'S = LOSS OF CONNECTION WITH LISTENERS

MP3 BECOMES MORE = AN INVITATION TO FEEL FREEDOM, OR VINYL AS IT IS A BETTER WAY TO VISUALLY CONNECT WITH THE CUSTOMER = A DIFFERENT INTERACTION

ALBUM ART IS JUDGED BY ITS COVER

NOT ALL ABOUT THE MUSIC ITSELF, BUT HOW MUCH THE ART VISIBLE MUST ACCOMMODATE FOR THE MUSIC & CREATE A STRONG IMPACT.

ALBUM ARTWORK IS JUST AS THE MUSIC - MUST CREATE A VISUAL IDENTITY FOR BOTH THEIR IMAGE & MUSIC

ALL ABOUT HOW IT IS VISUALLY DISPLAYED TO THE VIEWER TO SELL IT

ALBUM ARTWORK NEEDS TO COMMUNICATE THE CHARACTERISTICS & STYLE OF THE MUSIC

WILL BE JUDGED STRAIGHT AWAY MUST BE IMPACTING TO THE VIEWER

KEY PRINCIPLES AND ELEMENTS MUST RESONATE WITH THE THEME OF THE ARTIST & MUSIC, SO IT CREATES A COHESIVE FLOW & LEADS TO A CLEARER IDENTITY & IMPACT + MEMORY

VINYL = LARGE TANGIBLE FORMAT

INCREASE IN VINYL RECORD SALES = INCREASED IN APPRAISAL FOR THE FORMAT OF MUSIC

\* AIMED AT A VERY SPECIFIC AUDIENCE BUT WILL SELL AS THERE IS A STRONG DOWNWARD IN THIS FORMAT

CONTINUES TO BE IN VINYL SALES = GROWING MARKET

DEAR EDITIONS  
 - BOOKLETS  
 - INSERTS

\* CREATING A CULTURE AROUND THE ARTIST

- THROUGH  
 - ALTERNATIVE  
 - HIP

Niche Market According to a recent statistic, vinyl record sales have resurfaced in the 21st century. Starting in 2008, vinyl records have begun to see an upward trend in sales. Nielson Sound Scan reported that sales have increased by 17.7% from 2011. According to digitalmusicnews.com, "most [records] are being sold at indie retailers with a heavy lean towards rock" (Plesnikoff, 2013). The reasoning for these sales may be largely influenced by the album's artwork. Digital tracks are easier to acquire and are more cost effective. Some consumers like vinyl records because it allows the consumer to listen to the entire album. With CDs and digital tracks it is easy to skip songs on the album that may not be as popular. The choice between the two is preference. Some people who enjoy listening to the vinyl sound say "the experience is very similar to being at the live recording" (Upton, 2010). Whatever the reason may be, artwork is one of the key characteristics of a vinyl record, and people enjoy having a connection with the music to which they listen.

THE VISUALIZATION CAN BECOME THE SUCCESS OF ALBUM. DETERMINE

▲ This student, undertaking the design of a record sleeve, found relevant academic research. He was then able to identify key information to help generate and inform his design ideas.

methods such as interviews and market research. Your observational drawing of related imagery is primary research.

Secondary research involves the use of data or other information that has been collected by another source. Census data, books and articles are secondary sources. Secondary research may not have been created for the design brief but may still offer relevant insights and information, and usually contains analysis of primary sources. Use of design magazines is considered secondary research.

## COLLECTING RESEARCH

It is important to research intelligently. Research should be collated and sorted carefully, and used throughout the design process. Although the research stage is identified at the very beginning of the design process, its influence extends throughout the design task.

### Where to start?

How do you know where to start? It is important to have a purpose when researching. Using the design brief, you may choose to focus on the following areas to initiate your research.

### Research the client

Who are they? What is their background? Their location? What previous designs have they used/created?

### Research the user

Who are they? What do they look like? What do they do? How old are they? Where do they live? What designs appeal to them? How will they use the final design?

### Research existing and past design products that are similar

Which are most effective and why? Where are possible points of difference?

### Research other designs that have a similar function and context

How do they achieve the function required? How are they placed/used/displayed in their given context?

### Where to look?

The Internet is usually the first port of call for research and it offers a wealth of information; yet

## AUDIENCE RESEARCH: PERSONA

### RYAN



Age: 26

Occupation: Retail manager & Part time musician

Income: \$37,000

Personal status: single

Interests: Music & playing in a band regularly. Collecting vinyl records, travel, writing blog, gaming.

Technical profile: Regular internet user, extremely comfortable with technology. Uses web and mobile devices regularly to update blog, contribute to social media and some gaming. Has fast broadband connection running Mac OS and spends 10 – 12 hours per week online. Technical use: 20% at work, 80% at home.

- ▲ A persona or persona profile is a representation, both written and visual, of a 'typical' member of a target audience. Ordinarily they are fictional and personify the characteristics of the most recognisable audience members.

sometimes too much. It is advisable to look at a range of different sources for research and not rely on one source only. You also could create your own research by taking photographs, making notes and creating drawings.

## RESEARCH RESOURCES

### Electronic resources

The Internet is one of the most powerful information resources available. The sheer volume of available information from a wide range of sources makes this an invaluable resource.

Online databases provide access to articles and papers that might otherwise be unavailable to individuals outside specific industries and professional fields. Most of these services are subscription based, but many libraries have access to them.

There is a wealth of free information and images online provided by individuals and organisations. However, when seeking factual material, it is important to verify the source of the information given, as there are essentially no overall rules to ensure that all material published online is accurate. Email and social networks are important communication tools that can assist in the collection of information. Many manufacturers will provide company and product information in response to a request via email or offer information via their website or social media pages.

The availability of digital image technology makes the sharing of still pictures and video online quick and straightforward. Keep in mind that many Web images have a resolution of 72 dpi and are small in size to ensure that download times are minimal. Such images print poorly. Web images that have been enlarged can appear pixelated and blurred, making them unsuitable for presentation purposes, although they may be quite suitable for research. There are some valuable online libraries of stock photos that are free to use; amateur photographers and illustrators post their images and allow their work to be used for non-commercial purposes. The quality of these images can be quite high. Most content on these sites requires appropriate attribution of the source so ensure that you follow the guidelines set out by the copyright owner of the image.

When accessing online images and information Google Images allows users to search by image size, which makes sourcing high-quality images easier.

Social media have made understanding the preferences and tastes of an audience even more accessible. It is possible to evaluate interest in ideas, products and fashions by gathering information about 'trending' topics online. Trending is a term used to explain the popularity of key words and terms used on blogs and on social media sites such as Facebook and Twitter. The proliferation of an idea online is known as a 'meme' and a popular meme can spread rapidly via social networking. An example of a successful meme might be a popular culture reference, a quote from a TV show or a lyric of a song.

There are many design blogs online, which are a rich resource of design ideas and can provide an insight into current trends in design. Too numerous to mention here but easy to find online, design blogs offer opportunities to see evidence of contemporary international design at both amateur and professional levels.

When using the Internet for research, begin with an idea of what it is you would like to find. The information available online can become absorbing and time consuming, so beginning any search for images and information with a clear plan will make the most efficient use of your time online. As you search for information, record useful sites and email addresses in your notepad or sketchbook, or copy and paste the relevant links into a document or notes file. It is important to retain URLs of images that you have gathered to ensure that your sources are clearly identified in your work.

### Found materials

Look around you. Don't underestimate the usefulness of junk mail, direct marketing and free promotional material. Such publications can provide an insight into different markets and interest groups and may even inspire compositional ideas.

Free postcards, street newspapers and brochures that use illustration, photography and other methods to promote and advertise events and products may be readily available. Many corporate and non-profit groups use direct marketing as a relatively cheap means of gaining access to a broad section of the community. Often found in cafes, music and fashion retail stores, and entertainment venues, free postcards provide a wealth of visual material and potential research.

## Verbal resources

Valuable information about the design brief can be gathered from the source of the original need itself. Guidance from your teacher will be of great help throughout the design process; suggestions from another source can offer different directions and alternative interpretations of aspects of the design brief.

Discussion is a worthwhile research technique. Market researchers use questionnaires and surveys to gather information about the preferences and attitudes of a specific audience. Face-to-face discussion provides not only written data but also allows for the interpretation of vocal inflections and the physical body language of participants. Sometimes written material can be informative but it lacks the extra detail of a verbal or physical response.

Discussions with experts in professional fields are an important resource when responding to a design brief. An expert can provide first-hand knowledge

about techniques, the viability of production methods and information about product history. Initially, it may seem difficult to find an expert in the task, but asking parents, friends and teachers may lead you to people with expertise in similar or related fields.

## Literary resources

The library is a key resource in the collection of information. Libraries offer access to books, magazines, journals and the Internet, and library staff are extremely knowledgeable about the resources they provide.

Many libraries subscribe to a range of journals and online archives. It is possible to investigate the background of a company, product or service using resources such as these. Journals and magazines such as *Choice* offer objective testing and analysis of products, which could be a valuable resource in the development of product design concepts. Magazines that focus on

### IMPORTANT COMMENTS: NUMEROUS DESIGNERS, SIMILAR BELIEFS.

Due to certain constraints, I was not able to process all of the interviews. However, I thought it was important to show these responses, not only because they were from valid designers, but to show these similarities of ideas that stretched right across the industry spectrum.

#### UPCOMING MAGAZINE ART DIRECTOR, DREW TAYLOR.

Our setup is made up of really bad, modern, modular, corner workstations. They're too small (probably 1.5 metres of usable space in both directions) and they have that lovely fake wood veneer. An adjustable keyboard shelf is in the middle (though is completely impractical) and a movable set of drawers (on casters) sits under the desk. A shelf (about forehead height), lined with folders, is mounted along the edge of the partition that's hard up against a wall.

My lower PC sits just off centre and a 19" flat screen sits on a couple of stock art books to raise it to the right height. Plastic in, out and shake-it-all-about trays (five of them all up) sit to my right taking up most of the usable desk space there and the desk space on my left is filled with paper, burnt CDs, plates and past publications. (Not to mention a box of half-eaten Pizza shapes).

Two filing cabinets are further down the wall. And our photographic cabinet (full of camera gear) is over on the left.

Oh, please, design me something to inspire me. Not these awful, thought-less bastions of self sacrifice! Give me some space, some mood, some surfaces that aren't coated in veneer or cheap fuzzy material.

A desk that is actually designed to take a computer and get it out of the way would be nice. More space for folders, magazine holders, CDs and unsorted paper. A desk that isn't designed so that you use half the desk space behind the monitor. Better lighting. Not these awful fluores. Lighting built into the desk would be interesting. A desk design that doesn't have my back facing the rest of the office would be good too. An intuitive desk would be one that considers technology, workflow, lighting, 'creative space' (ie, enough space for laying out paper and doodling, or something similar), colours, alignment to the room and others, storage and more.

As a designer, if you were in the market to purchase to purchase a product like the one described. What factors would you consider? Such as ergonomics, features, styling and how would you prioritize these?

Strangely, how it made me 'feel' would be the first consideration. Does it make me want to be there. Does it inspire design. Does it create that 'huh' in your mind and your soul. Price would be second. Features and usability third. Strength, ergonomics, portability, and size fourth.

How would you define innovation?

The ability to take the way something is done and do it differently. Design is innovation. It's that simple. Take innovation out of design and you have manufacturing.

#### HOYNE DESIGN, ST.KILDA, MELBOURNE. ANDREW HOYNE.

Your brief of a manufactured integrated desk set does not really apply to the way we use space. To be completely honest, there is little about our desk arrangement that is any different to any professional person who uses a computer. We have desktop space to use for drawing visuals and developing ideas. However, there is nothing unique about it. My workplace is somewhere I want to feel comfortable. It's more emotional and less structural.

Who or what inspires you?

The people I surround myself with, especially my good friends. My staff and team. They are all talented individuals. And they have vibrant, energetic personalities.

How subjective is design? Is there such a thing as good design?

It's VERY subjective. It's all about opinions; popularity of a style at the given moment, fashion etc. That's what many of these issues are about. There is often not a right or wrong answer. Just what you believe. And what you can substantiate or support can only help you.

What is innovation? Innovation is being inspired by a respect for existing standards then surpassing them in your work. Your work should be a product of your passion; the engine-room of your enthusiasm and the personal pride in what you do. And it's fun when you believe in what you are doing. Work is an opportunity for us to be our best.

BRUNNEN'S EXAMPLE OF THE PHRASE 'CONTRASTIVITY' DEBILITATED A GOOD PART OF HOW IT SHOULD MAKE HIM FEEL AND UNWITTINGLY 'UNWRAPPED HIM TO DESIGN' AND HIS WORK. THIS MEANS HE WILL LATER REJECT OF IT - INSTEAD, HE CONSIDERS THAT EXCESSIVE UNWITTING.

A GOOD POINT HERE'S A DESIGN THAT THINKS A COMPUTER AND SHOWS IT OUT OF THE WAY. MOST UNWITTINGLY THESE DAYS (DESIGNS WITH THIS) HAVE THE TOWER IN FRONT OF THE DESK AND ARE ABOUT WHILE THEY TRY TO USE THE MONITOR. USE OF IT TO MAKE UPON DESK, THINGS LIKE SO (BUTTER MAKE) HAVE ALIVE A LARGE TABLE THAT COULD BE USED FOR OTHER THINGS.

#### KATALYST WEB DESIGN ADELAIDE, SA. KIPP BRADY.

My workspace is one big square desk (like an IKEA desk) that has my computer, scanner, cutting matt and associated junk on it. A bookcase full of design mags and books etc. A small filing cabinet which sits next to the desk full of good paper, files, and o's with a printer on top of it. Any drawing I do is on whatever space I can find.

I believe the bigger the workspace the better, at the moment I have no room for drawing, what with my computer taking up all the desk. More organization of the stuff on my desk would be nice also as pens and stuff are every where as well as cds and notes all over the place. If I were to buy a desk though I would be primarily for computer use so it would of course have to cater for one. Crappy Office Works computer desks dont cut it though. Finally a large area under the desk would be preferable so I can work on all sections of it without my legs getting in the way.

A customizable desk would be of interest to me, although the basis of it would have to meet my basic demands without requiring any other parts or extensive customization. That's not to say that I wouldn't appreciate any add-ons to it, its just that it would have to be of good use in its basic form.

A good solution would have a simplistic, minimal design, comfortable too use (for those long hours) good computer support (such as easy access to power-points) a large amount of work area and specific areas for paper, pens, rulers etc, whether these be in drawers or on the desktop itself. The ability to combine more elements too easily, which add to the style/ergonomics of the unit. Multi computer support should be achieved by the addition of further units to desk rather than supported in the one unit alone. Also an area for desktop speakers would be nice.

In the long run, if I was to buy a product like this, it will come down to price. I will of course pay more for better things but outlandish design or over the top features, which may provide a slightly better unit though add considerably to the price will be a turn off. Apart from that my list of preferences are styling number one, then features and finally ergonomics. The unit should also be quite sturdy as I plan to put alot of stuff on it.

SMARTER, MINIMAL DESIGN CONNECTED ON REDESIGNER AGAIN. KIPP WOULD OFFER PURCHASE. A PRODUCT THAT IS EASY TO USE AND EASY TO USE.

ALTHOUGH KIPP DOES MAKE MENTION OF LEG SPACE UNDER THE DESK, WHICH IS RELATED. I WOULD AGREE WITH HIS POINT AND WITH POINTS AT THE END OF HIS DESIGN OF MY DESIGN.

Ben Jennings

- ▲ In researching his design brief, this student used email interviews. The design brief specified a desk design for graphic designers, so the student contacted designers in Australia and overseas. He asked pertinent questions to gain information about the most appropriate design directions.



Made Publishers

popular culture provide insight into trends, tastes and fashion related to their specific market.

The Australian and international magazine markets are vast and there are magazines suited to all ages and interest groups, offering information about diverse audiences.

Books are, of course, an essential resource to any research, whether for information specific to the design brief, such as a book about the history of a product, or information that is related to the task, such as a reference book about ergonomics.

Many design and industry magazines produce an annual edition, giving an overview of design developments over the previous 12 months. These publications often select key movements, fashions and innovations, and showcase emerging and established designers and associated professionals. Similarly, compendium volumes of design examples – such as logos and typography – provide topic-specific overviews, as do some country-specific volumes, which focus only on designers from a defined region. The concentrated nature of these publications makes them valuable resources.

## Historical resources

Historical resources are not necessarily dusty old books in the archives of a library, but may relate to designs from last year or last century. The history of previous designs is a good place to start researching the success and failures of the past. From existing constructions, products or compositions it is possible

to analyse the application and effectiveness over time of construction materials, content and the elements and principles of design.

‘Retro’ references are often made in design so it is good to familiarise yourself with past representations of your design task.

The National Library of Australia archive old photographs, newspapers and journals for reference, and permit viewing of many primary sources. Photographic and physical records of social, environmental and geographical changes can be found at local museums and historical societies. Such material can offer insight into not only the appearance of past designs but also their application and context.

Your local area may also provide clues to past designs. Using a camera and a notebook, you can collect images and ideas from local buildings, antique or junk stores, and landmarks.

## Demographics

Demographics involve the analysis of statistical information about a population. Demographic data provides information about trends, ethnic diversity, average age, education levels and current interests. Companies use demographic information to make decisions about product development. This data provides the company with clues to common sets of values and attitudes of consumers. When marketing professionals use buzzwords and phrases such as ‘the target demographic’, they are simply talking about an audience that shares common characteristics.

# MARKET RESEARCH

## PRODUCT SURVEY - VISUAL COMMUNICATION #1

### ACCORDING TO THE AUDIENCE

I conducted a survey on the following products. I asked the audience which products they preferred visually, and which ones they would personally purchase. I also asked them to comment on any visual aspects of the products.

**Product #1** - <http://tinyurl.com/qjzjske>

**Product #2** - <http://tinyurl.com/q5dt9mo>

**Product #3** - <http://tinyurl.com/nmwd7r4>

**Product #4** - <http://tinyurl.com/hoshx4x>

**Product #5** - <http://tinyurl.com/q5dt9mo>

*Handwritten notes:*

- Product 1:** They expressed the colours involved as being 'old' and 'sickly outdated'. Most of the survey audience didn't really like this packaging. They expressed it as looking 'outdated' and 'something my grandma would use.'
- Product 2:** 'Rustic' like. Contract of the btw impressive contemporary + traditional. Ascop's Design was highly liked. The people surveyed described it as 'scientifically traditional'. They recognized the environmental impact & aesthetic of the product.
- Product 3:** Clarins was labelled + recognized as 'traditional'. The typography was described as 'outdated'. COLOUR CHOICE CLEANLY UNPEELING. \* The french labelling design was depicted as 'typical' and 'didn't have the ability to stand out in a contemporary setting'.
- Product 4:** \* The audience expressed the 'AVEDA' products to be 'boring and typical'. The eco-friendly aspect was recognized, however not thought to be recognized in a contemporary setting. \* One member expressed their like for the simplicity of the packaging, and assumed the product would contain 'nourishing properties'.
- Product 5:** \* The modern white + blue, 'contemporary but not outdated'. Clean, modern and appealing to a younger audience was what most surveyed individuals said. Blue + white being represented irrevocably was recognized as an innovative design aspect & consideration.

Lucy Boehme

▲ The design brief required this student to design packaging for organic skincare products. In gathering research, the student showed a selection of existing packaging designs to her target users and noted their responses. This informed some of her decision making about packaging forms, textures and materials.

Government agencies also collect vast quantities of data about Australian citizens. This information is then used in the development and distribution of services and the deployment of government funding. A national census is held every five years to gather information about employment, household characteristics, education and lifestyles.

**LINK: AUSTRALIAN BUREAU OF STATISTICS**

Census data can be viewed at the Australian Bureau of Statistics website. You can link directly via <http://vcd.nelsonnet.com.au>.

Remember that research is often ongoing throughout the design process. It is important to be aware of trends and developments. So, as you design, keep an eye on your target user and the factors that influence them.

## ORGANISING AND INTERPRETING RESEARCH

We are surrounded by a wealth of visual, verbal and written information – so, how do we determine what research will be of value to the design process?

Organisation is the key to using researched material effectively. Organise your research into clearly defined categories, such as:

- + research specific to the end user
- + research of similar products with a similar function
- + research of materials and media
- + inspirational material: layout, design elements and design principles, media, materials.

You will discover that your research has provided you with information directly related to your user, the context of the planned design and some items that have a similar function to yours. This material will assist you in understanding the design problem and will allow you to make educated decisions about the suitability of proposed graphical representations.

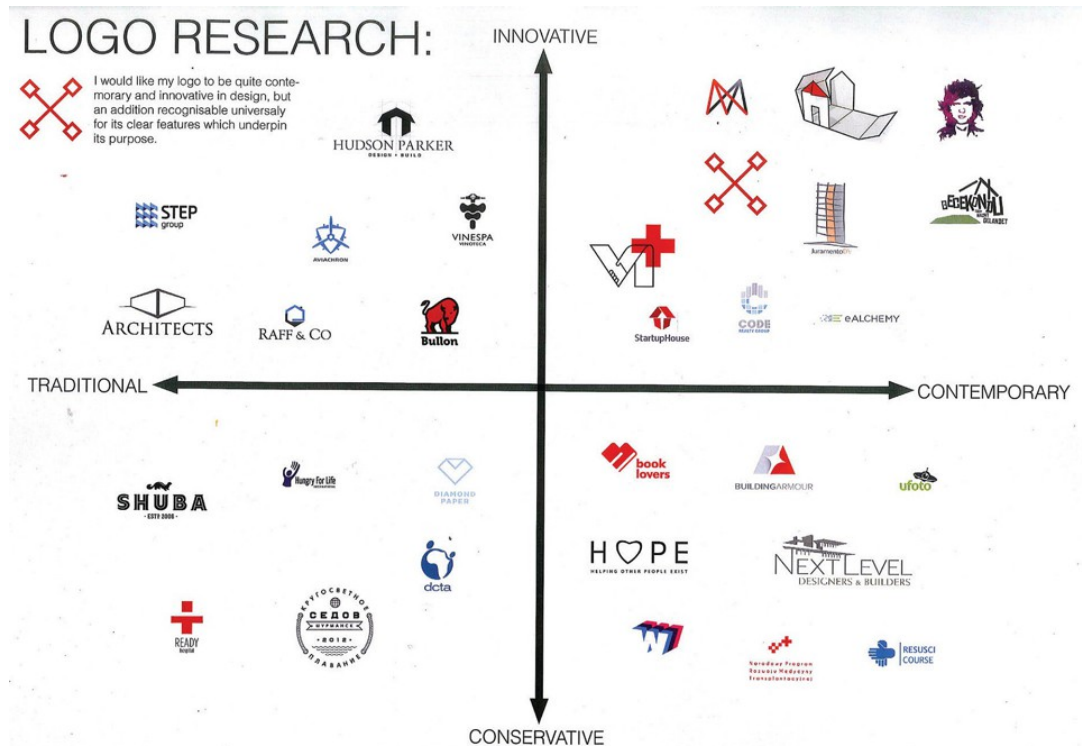

Nicholas Rose

▲ This student used a scale to organise researched images of corporate identities. Organising the collected logos into four quadrants, the student could identify which were the more innovative, conservative, traditional and contemporary of the images. He was then able to identify where he would like his own design to fit. This organisational tool can be very helpful in defining the aesthetic qualities and direction of a design idea.

### Annotating research

**Annotation** is the best means of indicating – to you and to others – the value and meaning of researched materials.

- + Insightful annotation indicates that you can analyse researched material.
- + Write about why you have chosen to use the research you have.
- + Explain how you might use your research in the design process
- + Indicate which aspects of the research might give you starting points to generate ideas.

## GENERATING IDEAS

The design process is extremely flexible – it allows for creative ideas to evolve from diverse sources. The design process has a definite structure but it is also ‘elastic’, allowing designers to experiment with countless media, materials, methods, elements and principles to achieve a suitable design solution.

The way in which a designer responds to a brief can depend on personal and professional preferences. Some designers work in teams where different tasks are taken on by co-workers. Some designers work alone, or may call on the assistance of external specialists.

For inspiration, a designer might use concept maps and word lists as well as thumbnail sketches. To give the designer a large pool of ideas to work from, design companies often use group discussions during the developmental stages of the design process. The use of a concept board (also known as a ‘mood board’ or a ‘look and feel’ board) is a common method of gaining ideas and inspiration. The concept board is a collage of images, words and ideas based on the brief or a related theme. Images, swatches and words are combined to suggest possible design directions.

In the initial stages of a brief, designers respond in a variety of ways. Personal preferences dictate the methods used to explore and present initial concepts, but most designers begin the design process with simple thumbnail sketches in pen or pencil on paper. Drawing is a quick and hassle-free way of getting



early ideas onto paper; it also provides a means of communicating concepts with other professionals involved in the process. Freehand sketches may contain minimal visual detail at this stage, and are often accompanied by notes (annotations) explaining the concept in more detail.

This stage is also referred to as the **ideation** stage, a point where the ideas – rather than any concrete concepts – are the primary focus. This phase of the design process invariably provides a lot of freedom and allows designers to explore many possibilities. It is important to ensure that the initial focus is broad rather than narrow at this point in the design process.

Generation of ideas involves:

- + concept and mood boards
- + brainstorming
- + initiating ideas through sketches

- + communicating ideas with other design professionals
- + beginning with a broad base of ideas to work from.

Throughout this stage of the design process, you will be applying different thinking skills to the practical tasks you undertake. These skills assist in helping you to generate the most creative options for your design. There are many techniques and strategies available to brainstorm ideas (see Chapter 9 for more detailed information about design thinking).

Brainstorming is the application of small, stimulating tasks that tap into the imaginative resources of your mind. These tasks are designed to exercise your brain or to help expand on an idea that needs a bit of a push. There are software programs that can assist you in brainstorming ideas and help to build concept maps and idea diagrams; there are also many helpful books available on the subject.

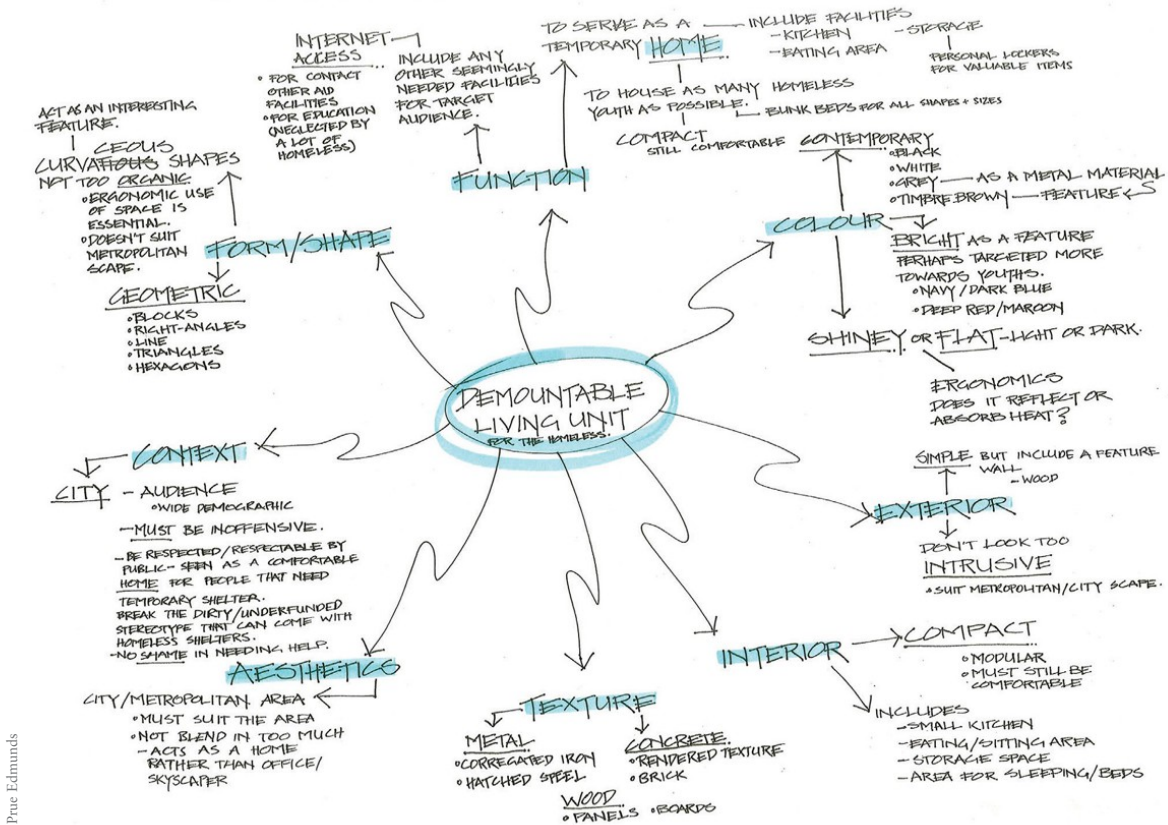

▲ This student used several techniques to stimulate design ideas for a small residential structure. The concept map provided starting points for the generation of ideas including the form and function of the building.



## DRAWING TO GENERATE IDEAS

There is no formal method of learning to think visually, but drawing expands our ability to represent not only what we see around us but also what we see in our imaginations. Practice is key to building skills in drawing. The more you draw the better your drawings will become; it is that simple.

This stage of the design process is about the generation of ideas and involves quick drawings drawn directly from observation or from material found during the research stage. Thumbnail sketches allow for the exploration of initial ideas that can later feed the development of more formal design concepts.

### Observational drawing

Observing objects within an environment assists in recognising and representing form, relationships, scale and proportion. Observational drawings can be in colour or black and white, and in any medium

When generating ideas...



- ▲ The generation phase of the design process should be free from judgements and restrictions. Generation is an opportunity for unfiltered creativity.

you feel best displays the qualities of the drawing. They are usually fully rendered and indicate a clear understanding of tonal variations, light and shadow,

**IDENTITY: GENERATION**

**Annotations:**

- "1602" BEING KEY WORD IN IDENTITY/NAME → EMPHASISED BY PLACING IT INSIDE THE LABEL ABOVE.
- \* STILL PREFER TYPE-BASED LOGOS OF SIMILAR CONCEPT TO THE ONE IN TOP LEFT... MORE VERSATILE, OLD-FASHIONED / ANTIQUE - YET NOT DATED.
- BOTH ATTEMPTS AT SUGGESTING AREN'T SUCCESSFUL...
- LABELS ON APOTHECARY JARS CREATING: "CIRCA 1602 TRADING CO.", ETC.
- OLD 1/2 SHIELD SHAPED LABEL | LOGO IS TOO DATED, ALSO NOT AS VERSATILE - THE LOGO NEEDS TO BE SUITABLE FOR BUSINESS (PHOS, JARROUSE & BISHOP, TRADING, ETC. IT NEEDS TO BE APPLIED SUCCESSFULLY ON BOTH TINS (CYLINDRICAL OR 2 SQUARE).
- MORE VISUALLY INTERESTING; USE OF HIERARCHY - CLOSER, MORE RELATED ARRANGEMENT.

**Sketches:**

- Top left: A rectangular label with "CIRCA 1602" and "TRADING CO." below it.
- Middle left: Three hand-drawn bottles with labels "CIRCA", "1602", and "TRADING COMPANY EST...".
- Middle right: A group of three bottles with labels "CIRCA", "1602", and "TRADING COMPANY".
- Bottom left: A shield-shaped label with "CIRCA 1602 TRADING CO." and "Est. 2010" below it.
- Bottom right: Three variations of labels: "CIRCA 1602 TRADING COMPANY EST. 2010", "CIRCA 1602 TRADING COMPANY EST. 2010", and "CIRCA 1602 TRADING CO.".

**Photographs:**

- Top left: A photograph of several vintage medicine bottles on a wooden surface.
- Bottom left: A photograph of three bottles of "Vintner's Choice" wine.
- Bottom center: A photograph of a white rectangular tin and a cylindrical container labeled "BESCHUIT" and "De Ruijters' Bestaarte Muisjes".

- ▲ Inspired by vintage packaging, this student made an observational drawing of old tins and containers to develop her skills in representing proportion and form.

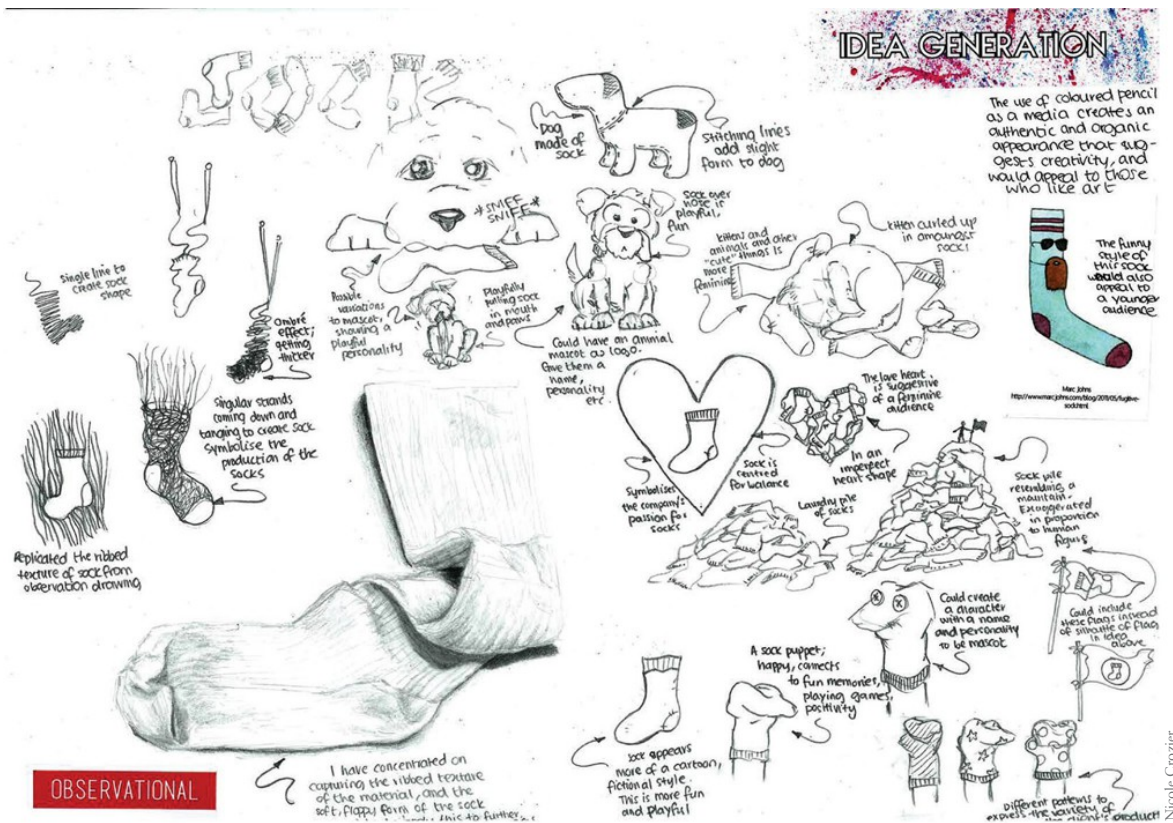

- ▲ This student undertook a design brief for an identity and promotion for socks. Her observational drawings helped to identify the qualities and appearance of a sock's form.

as well as surface textures. Observational drawings can develop your familiarity with the appearance of objects, which in turn leads to increased authenticity in your **visualisation** drawings. There is no limit to the number of observational drawings you may choose to generate and they might be useful to execute at any stage in the generation and development of ideas that meet the design brief.

## Visualisation drawing

Visualisation involves sketching to get your hand and brain thinking together to stimulate creativity.

Visualisation drawing is a method of visual thinking and involves getting as many ideas onto paper as you can. Using research and brainstorming as a stimulus, focus on simple representations of the design idea initially.

Thumbnail sketches are the most effective means of getting your ideas onto paper. These drawings are designed to communicate your initial ideas and are the first of your visual steps in response to the communication need. The sketches do not need to

be detailed but they should depict your concept and provide you with sufficient visual information to build upon as your ideas develop.

Varied use of media in the early stages of design concept development is encouraged, as the properties of different media can have a direct impact on the direction of a creative idea. For instance, pencil rendering will give an object an appearance that becomes quite different when rendered with markers or pastel. Be open to the qualities of different media.

Early sketches and drawings are an opportunity to test the viability of concepts in relation to the design brief, and this should be indicated by clear annotation.

Freehand sketching of initial ideas created during brainstorming is, perhaps, the most valuable method of idea generation. Visual thinking is a term used to describe visual brainstorming. Thoughts, ideas and concepts may be extremely vague in the initial stages of the design process but through drawing they can be more clearly explored. (See Chapter 3 for more information about sketching.)

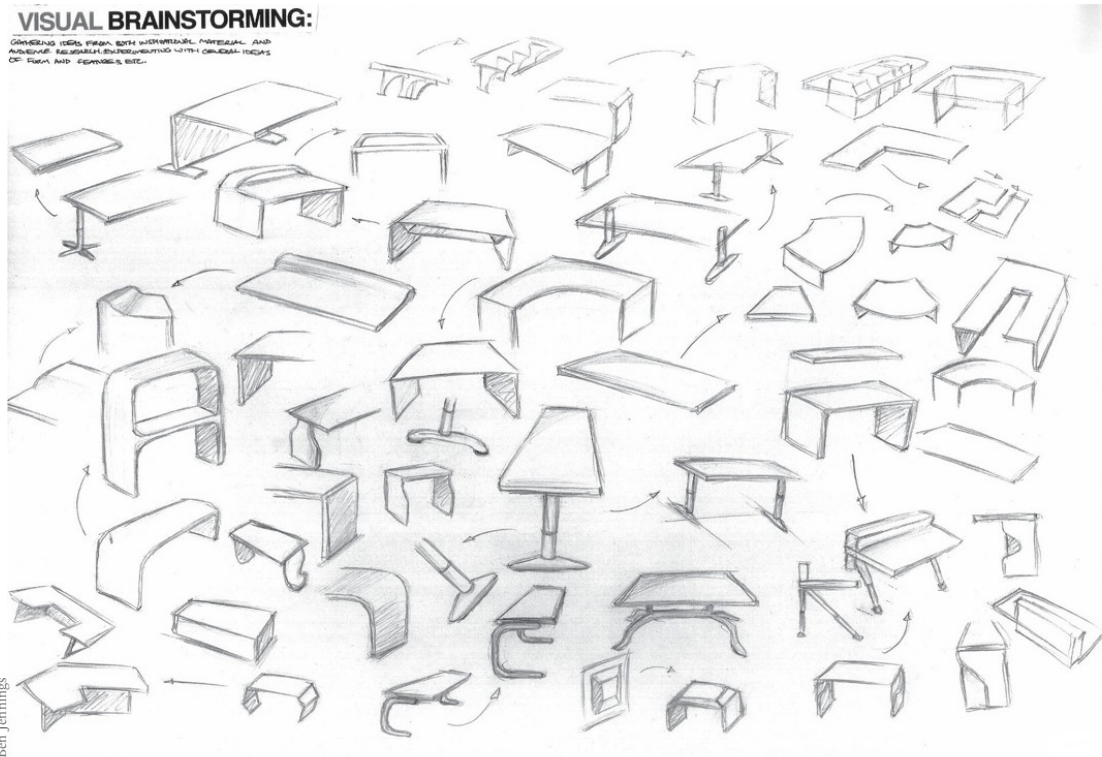

### TIP: FOR VISUALISATION DRAWING

#### Start simple

Draw the simplest representations of your design ideas first. Focus on shape to begin with – perhaps draw the front view of your design, followed by a simple three-dimensional representation of the form to follow.

#### Questions lead to answers

To push the possibilities of an idea, ask questions as you draw, or when you reflect upon a drawing: ‘What could I change?’ ‘What would happen if ...?’ Rather than answering the questions in your mind, answer them with another drawing. (The SCAMPER technique can be applied here if you get stuck for questions to ask yourself (see page 212).)

#### Choose your media

The temptation to erase a less successful idea can be strong. Avoid the temptation by drawing some or all of your early ideas

in ink (fineliner) or ballpoint pen. Don’t waste time reflecting on an unsuccessful drawing, move quickly onto the next version and address the changes there.

#### Practice really does make perfect

The more you draw, the better your visualisation will become. Drawing is a physical activity like any other and will improve with practice. The more you draw, the more explicit the communication of your ideas will become.

#### Generate ideas in 2D and 3D

When appropriate, visualise your design in both 2D and 3D methods. Plan or top views can be of great help in environmental design and product design, and three-dimensional representations help to explain more detail about the form of an object. Where possible, apply drawing methods that you are familiar with, such as perspective or planometric. Freehand drawings in these methods are highly effective and add realism to your ideas.

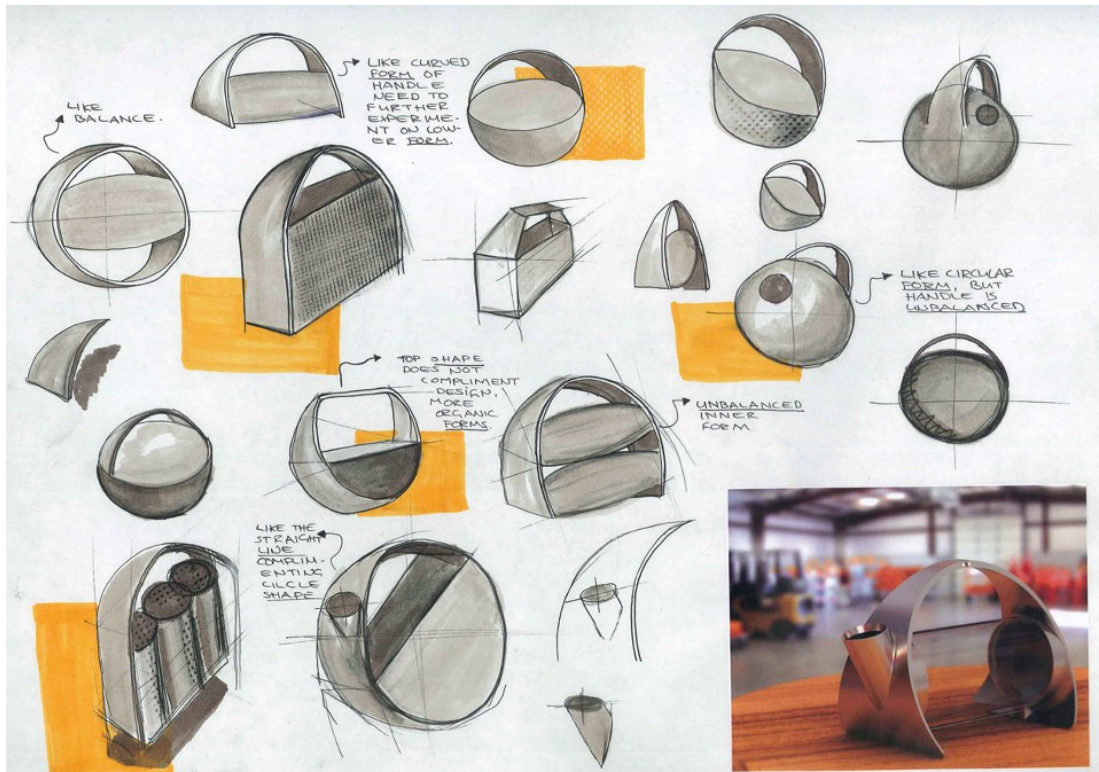

Ellen Keillar

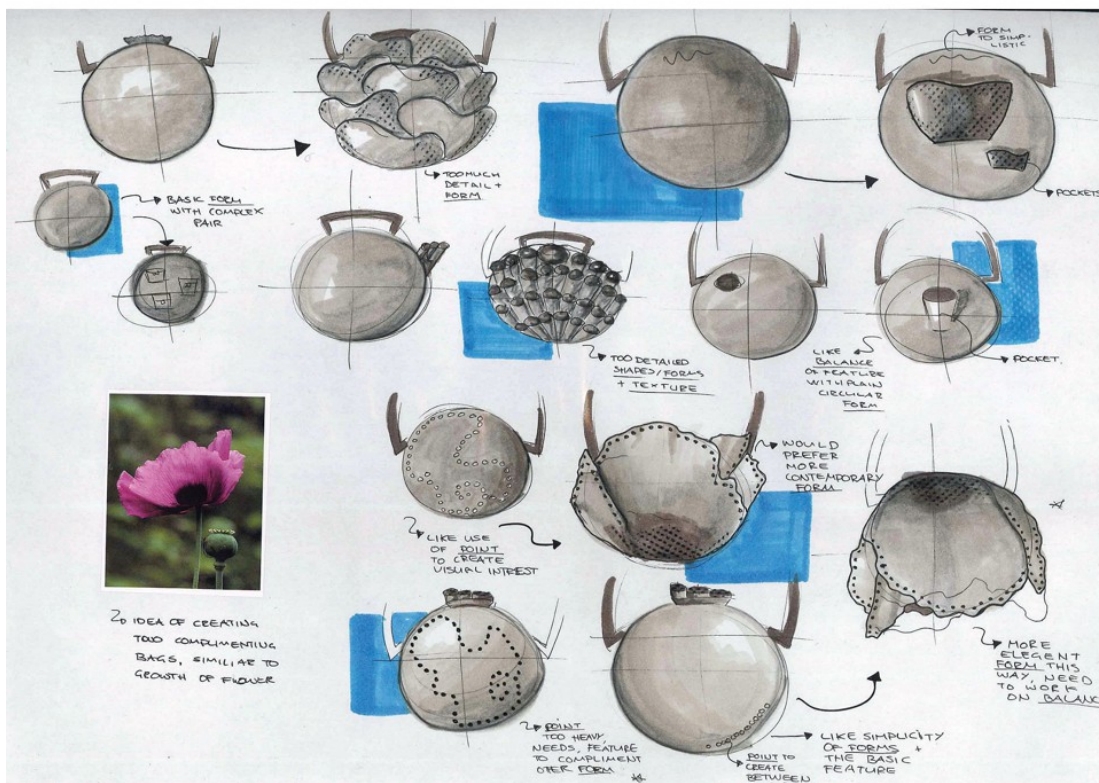

Ellen Keillar

▲ Generation of ideas for handbag design. Note the use of rendering and 3D methods to emphasise form.

FORM: BREAKDOWN OF BASIC SHAPES

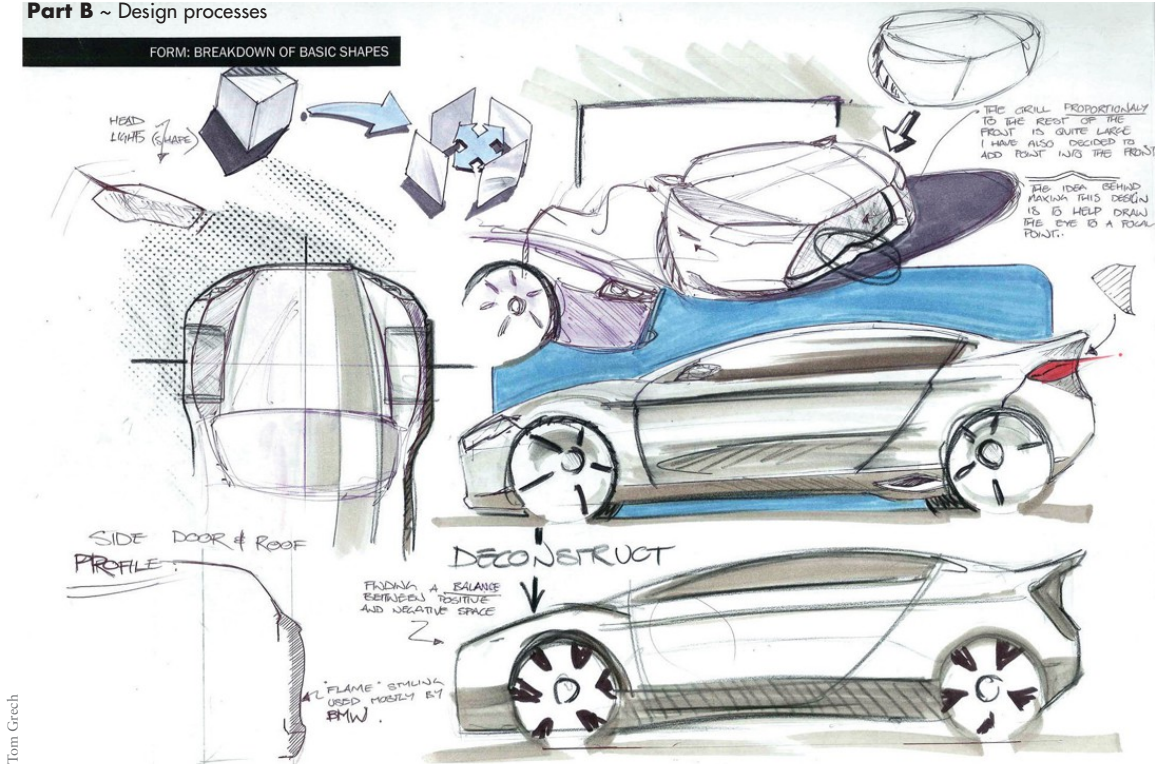

Tom Grech

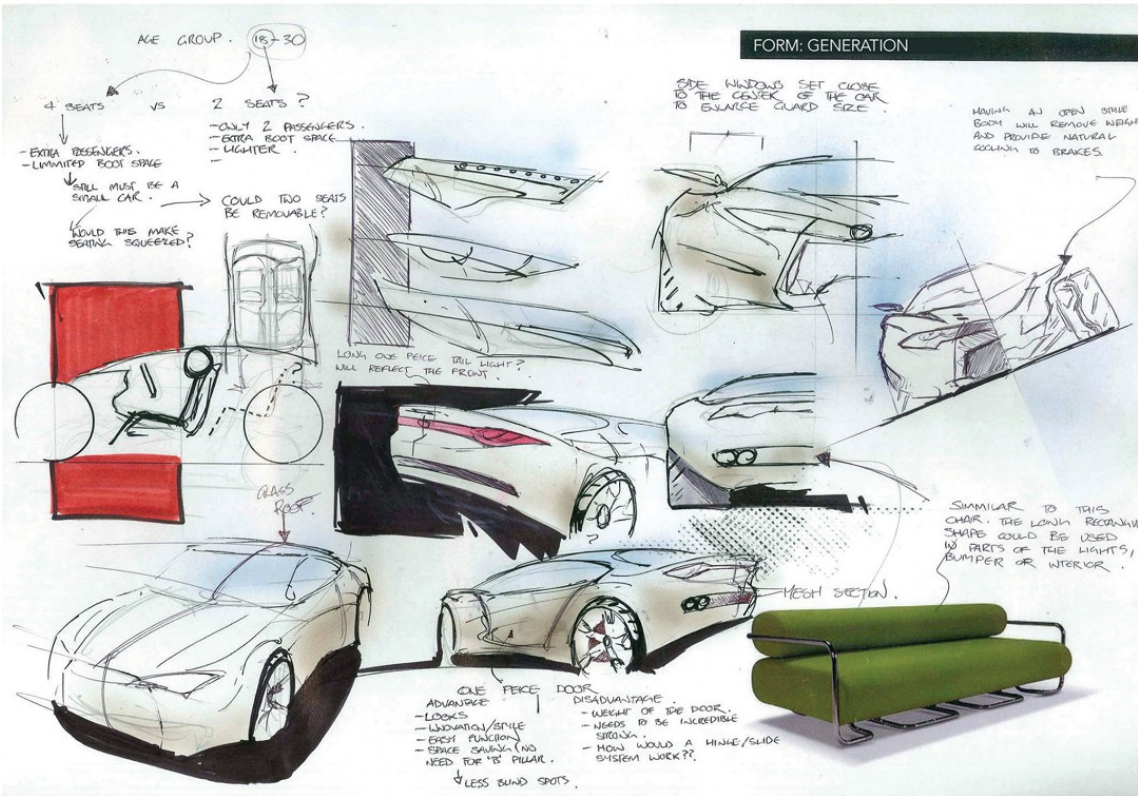

Tom Grech

▲ Generation of ideas for a vehicle design. Note the way that this student has drawn his design ideas from multiple angles to visualise different design possibilities. Drawings in this stage do not need to be finished, polished presentations. The focus is on getting ideas onto paper.





## DEVELOPING CONCEPTS

The development of ideas involves decision making. From the broad base of creative concepts generated in the earlier stage of the design process, designers select the concepts that best fit the design brief.

During the developmental stages, designers continue to look to the brief and the initial research for inspiration. The design brief is the core that travels through the entire design process, ensuring that even the most experimental ideas refer to the brief for

guidance. Decisions regarding the application of design elements and principles are based on not only what is the most creative solution, but what is also the most effective solution in line with the brief.

Throughout the development of a design concept, the designer will continue to ask questions: Does it fulfil the needs of the client? Will it appeal to the target audience? What materials and media will be best suited to the final design?

Testing of elements and principles, methods, media, materials and presentation is a constant process. Numerous methods are used to validate or reject ideas. Discussions and focus groups may continue to be used to assess and evaluate ideas.

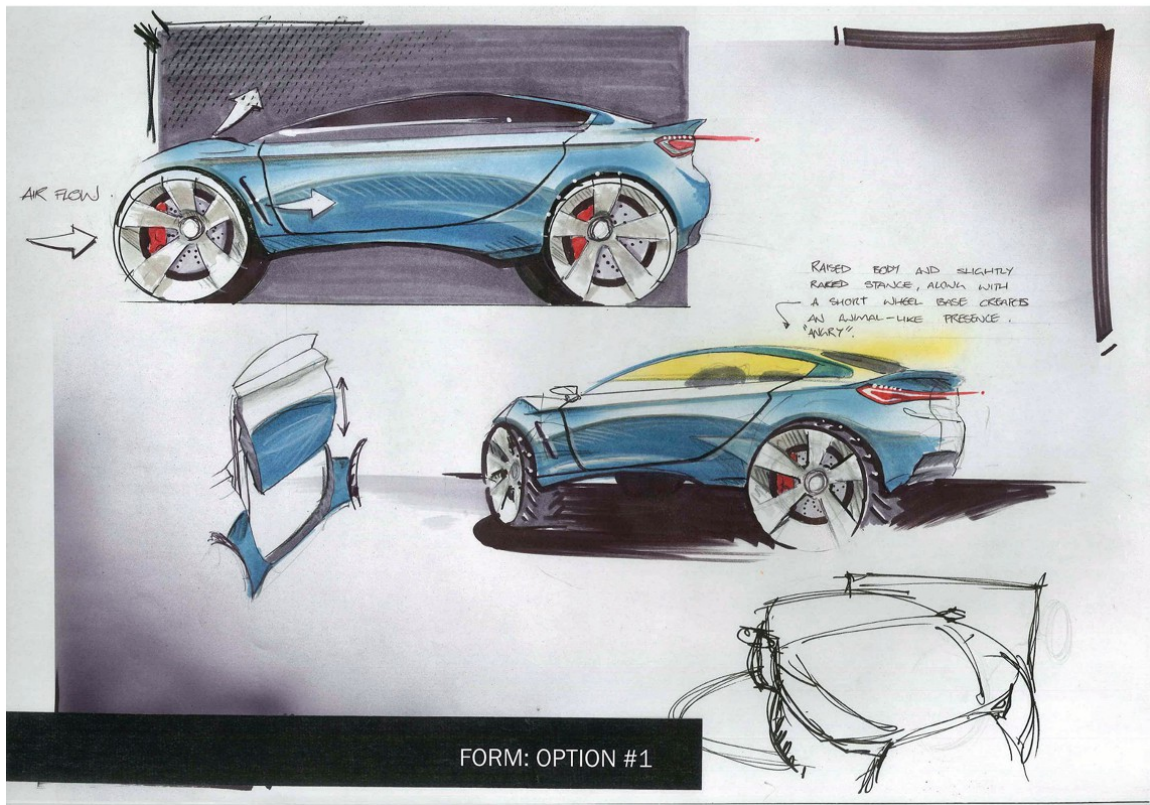

Tom Crech

FORM: OPTION #1

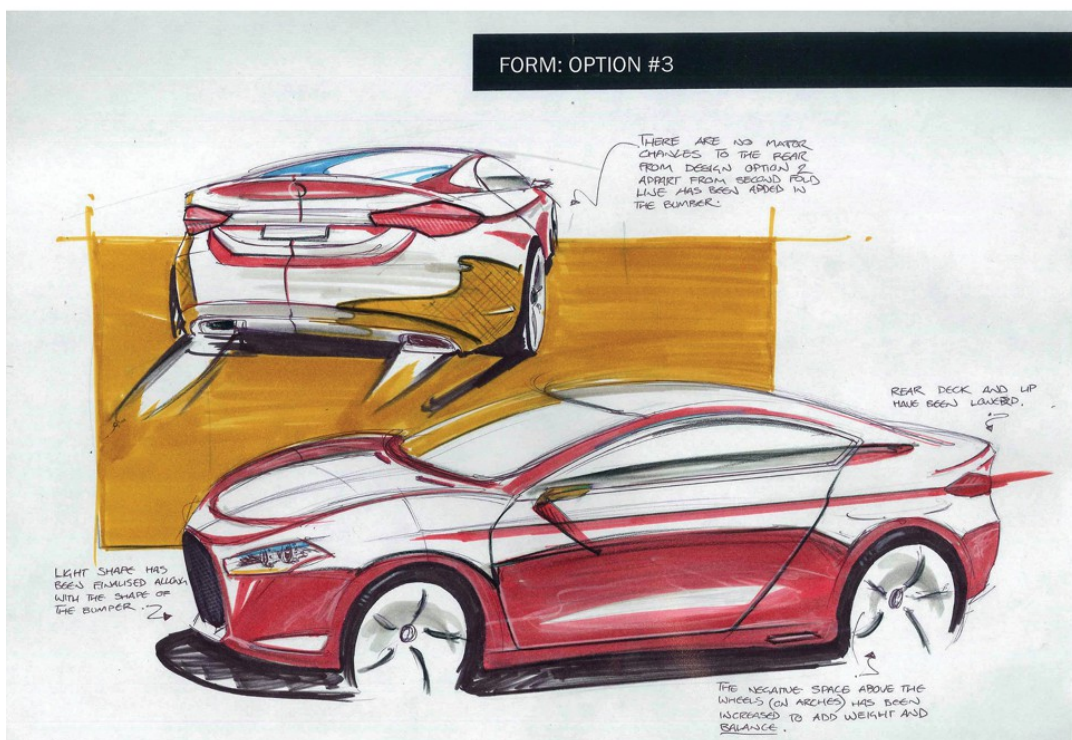
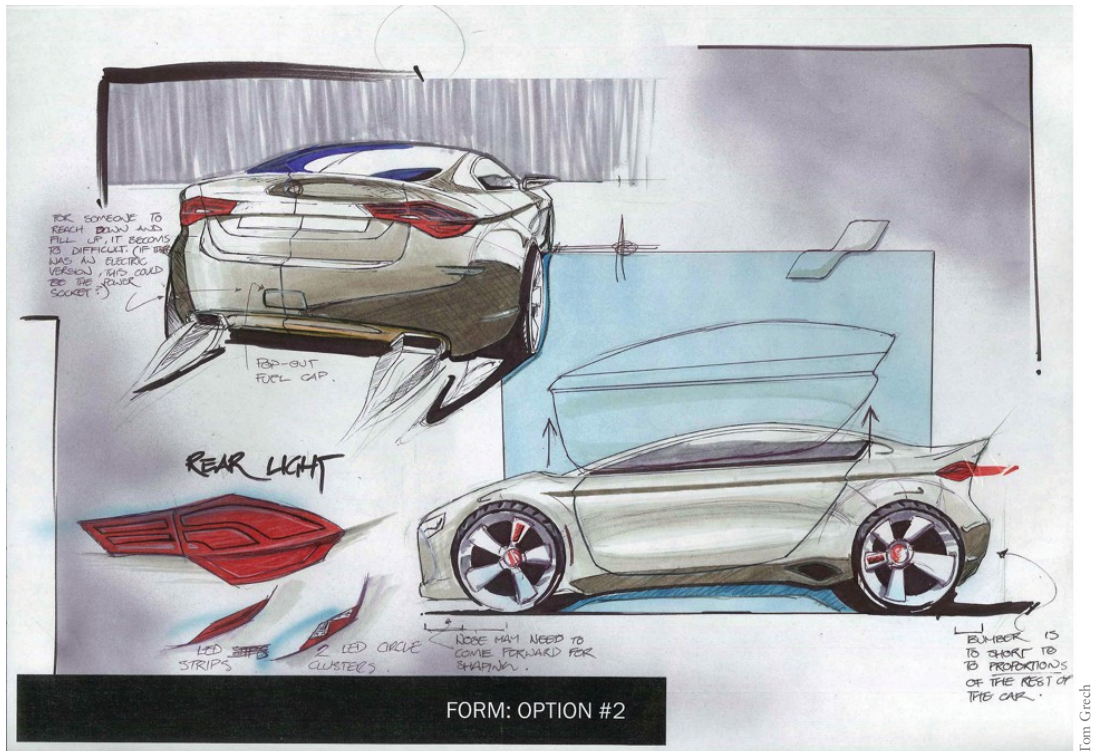

- ▲ In generating different design ideas, this student devised three options in his vehicle design. The design process enabled him to experiment with different details, colours and materials as well as design principles such as balance, scale and proportion, until he decided on his preferred final concept.

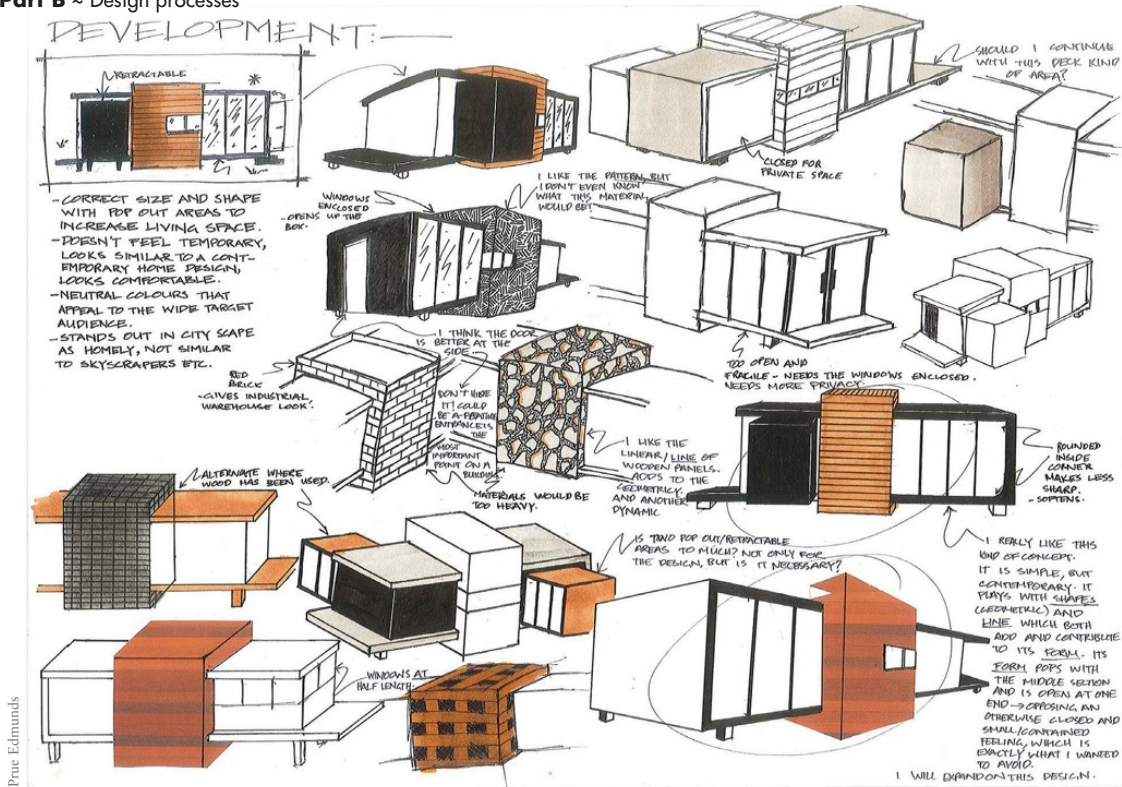

Prue Edmunds

▲ This student used freehand sketches to experiment with different materials before moving on to digital design and rendering of her structure.

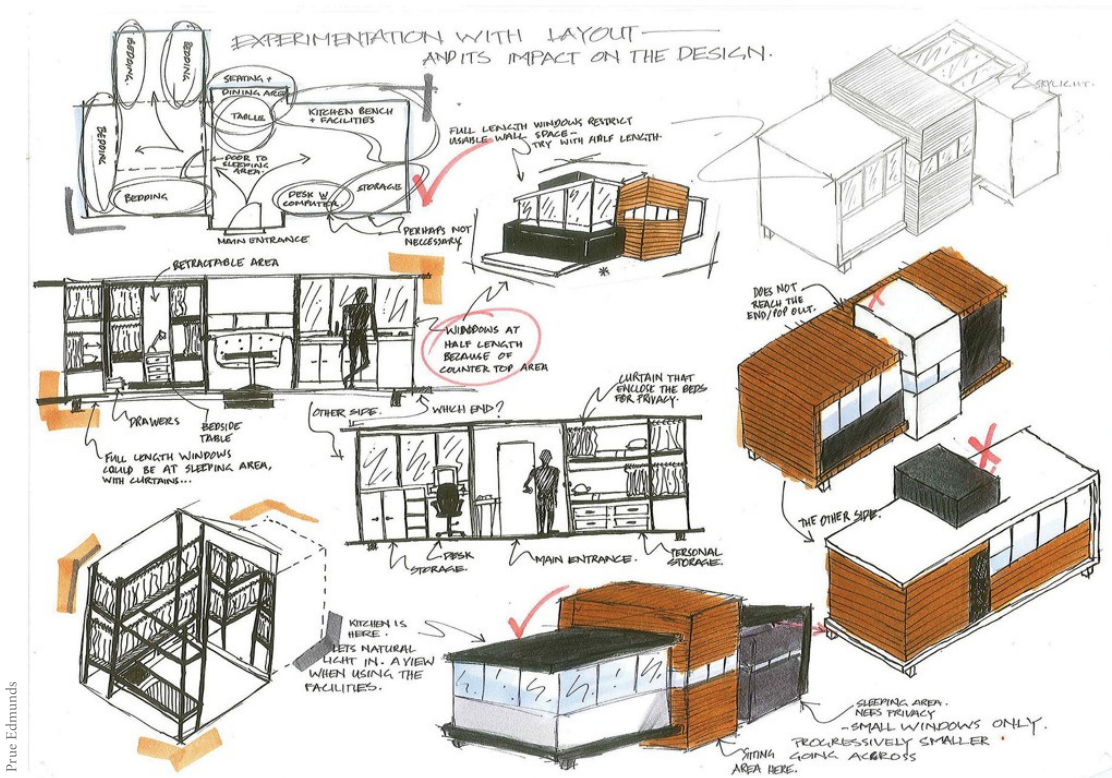

Prue Edmunds

▲ Sketching the interior of the design assisted this student in making decisions about the feasibility of her structural design.

### DEVELOPMENT

18 CONCEPT 1

Using oil pastels to create a very hand-drawn, authentic appearance

The colours of the oil pastels should all be more in contrast to the black paper

An ombre from one tone to the next

Very dry brush used here

The blank white space in the centre helps to breathe up the design's overwhelming colours

Two sides of a box shaped net

Makes the design less overwhelming: more simple

Without white outlines, shape of triangle stands out, due to figure ground of dark and light tones

Could we go back to more similar designs to give the surface of the package...

Interesting texture, have been created

These colours also look nice with brown paper

Colour stands out well on the black paper

Could cover each pattern in the two sides of shape of this design

Here I have used a thinner paintbrush to draw the white outlines, this looks more appealing

A relaxing, care-free style

The use of a dry paintbrush creates a sketchy, roughy texture. I feel that white aspect to...

Here I have printed goache onto the black paper by transferring it when it is wet...

Nicole Crozier

### DEVELOPMENT

Faces to be applied on the side of a package like below. One of the faces shown is repeated on each side of the box, with six different boxes in total in the range available for the customer to collect

The top of the box could be in the middle of the same shape design that is around the faces

Here I have applied a 'Texturizer' effect to the design to help make it appear as if it was made of a sock-like material

For the sides of each box, the same colour is closest to each other. In the case the dark blue is closest to each other when going around the corner to the other face

Here I have added the 'Graphic Pen' effect to make the design look sketchy and hand-drawn. This would really appeal to an artistic, creative audience, and the black and white simplicity would complement the colourful logo well

The pencil does not look as nice when put into the computer

I edited the photo on photoshop to enhance the brightness and saturation of the colours

A contrasting coloured strip that could be part of the package design or otherwise a strip of ribbon or other material

I have added a repeated pattern of a sock image, which could help the audience to quickly identify the products that the company sells

Nicole Crozier

▲ Experimentation with manual and digital methods as well as a range of media and materials were a feature of the development phase in this student's folio.

If required, professional specialists such as photographers, illustrators, animators, Photoshop artists and Web developers may be briefed on aspects of the design during this phase. Creative professionals who specialise in highly specific areas play an important part in the development and production of visual communications.

Development of ideas involves:

- + selecting the most suitable concepts for development
- + testing media, materials and methods
- + experimenting with design elements and principles
- + referring to the brief to ensure that the designs are on the right track
- + discussion and assessment of the most effective design solutions
- + a relationship with external design professionals.

In your own design process, as you draw and analyse your concepts, you are making decisions about the direction of your work. Your annotation reinforces and enhances this process. Your approach to the development of design ideas may be structured or quite experimental and exploratory. Whatever your development 'style', your workbook should show the visual path of your decision making (see the diagram below).

Testing is not about trialling every element, principle, medium and so on in order to make a decision about each visual aspect of your design. It is about using the knowledge you already have to select the most appropriate means of conveying the purpose of the visual communication.

In your design work you should show experimentation with:

- + design elements
- + design principles
- + a range of media
- + a range of materials
- + two-dimensional and three-dimensional drawing methods
- + manual and digital methods
- + aesthetic considerations
- + presentation formats for the final presentations.

Ask the following questions during the trialling and testing of design alternatives.

- + Does the concept address the purpose of the brief?
- + Will the concept appeal to the target audience?
- + Is the concept appropriate for the intended context of the visual communication?
- + Have I made the most of the design process and extended and experimented with my ideas?

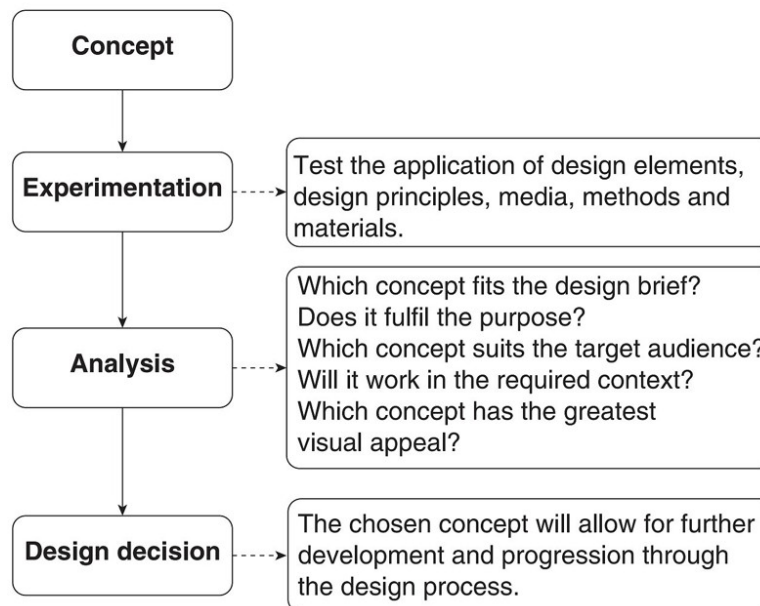

▲ Experimentation with concepts and the trialling of design alternatives are important and should include thoughtful and insightful annotations. To ensure that your experimentation and decision making are worthwhile, think carefully about what you need to test.

- + Have I explained my decision making through annotation?
- + Have I used a wide range of methods, materials and media?
- + Have I experimented with design elements and design principles, either individually or in combination with one another?

- + Have I used a range of manual and digital technologies in exploring my ideas and testing my design alternatives?

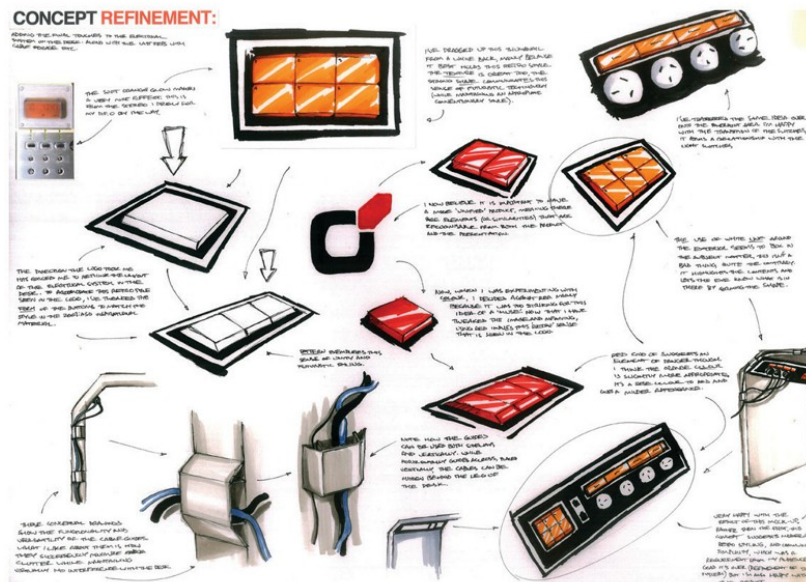
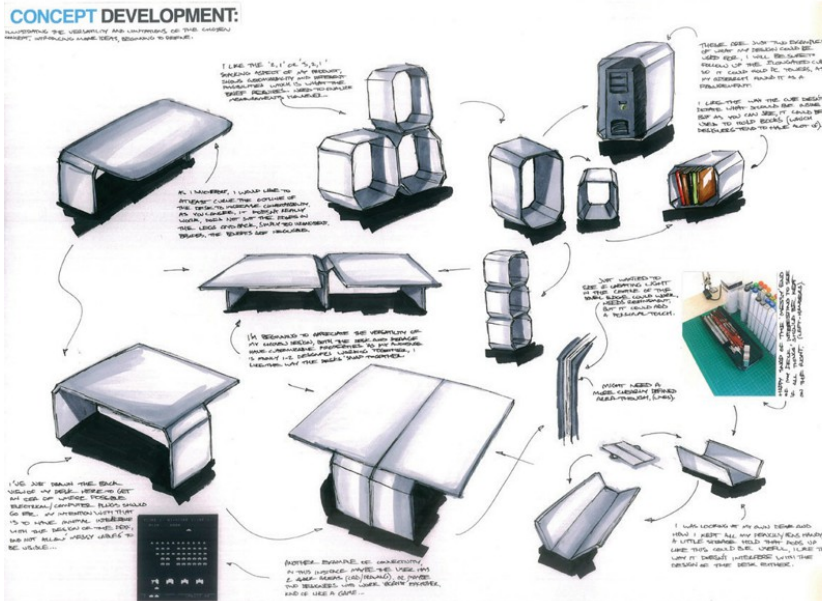

▲ In developing the details of his designer's desk, this student focused on the functionality of the product using knowledge gained from his extensive research and creative generation of concepts.

THIS DESIGN IS QUITE DIFFERENT IN THAT IT DOES NOT HAVE A BUTTON. THERE IS AN UPPER PART & LOWER PART ATTACHED BY SPRINGS

TO STAPLE PROPERLY, FORCE SHOULD BE APPLIED EQUALLY ON THE TOP

ALL LINES PERPENDICULAR

ONLY FORCE AT THE FRONT → IT WON'T STITCH CORRECTLY AND MIGHT DAMAGE PAPER

THE CORRECT & INCORRECT WAYS SHOULD BE NOTED TO AUDIENCE ON THE PACKAGING

PULLING APART TO SEE IF THIS IDEA WORKS

THIS METAL PART IS USED TO MAKE THE STITCH; THE MAIN COMPONENT THAT ENABLES THE STAPLER'S FUNCTION

WITH NEON STRIPES THE STAPLER LOOKS MORE STRIKING

AS SPRINGS ARE PLACED IN THESE HOLES

LOOKS LIKE THE CUBIC STAPLER LYING ON ITS BACK THIS SHOULD FUNCTION FINE AS NOTHING IS DIFFERENT EXCEPT FOR THE ORIENTATION

PROBLEM: THE GRIP OF A 40-50 YEAR OLD USER MIGHT NOT BE STRONG ENOUGH TO STAPLE PROPERLY. ALSO, BOTH HANDS ARE NEEDED TO HANDLE THE TASK: ONE HOLDS STAPLER & ONE HOLDS PAPER. THEREFORE THIS DESIGN MIGHT CAUSE MORE INCONVENIENCE FOR THE USER

THE SLOT IS ON TOP FACE

THIS DESIGN IS PRETTY BALANCED.

2 BUTTONS ARE ON THE SIDES

COLOURS TOO SENTIMENTAL

PARALLELOGRAM SHAPE

THE CUBIC FORM IS MORE CONFORMED BUT IT LOOKS BETTER THAN THIS

THE BASE SIGNALS THAT HERE'S THE BOTTOM, AND THE STAPLER SHOULD STAND THIS WAY

ADD THE BASE, SO THE AUDIENCE WILL NOT BE CONFUSED ABOUT ITS ORIENTATION

SIDE VIEW

TOP VIEW

PLAIN SURFACE

SIMPLISTIC GEOMETRIC FORM, LINES

Nhu Duong

# EVALUATION

I PICK 4 BEST DESIGNS FROM 2 CONCEPTS AND EVALUATE THEM AGAINST ONE ANOTHER AND THE BRIEF TO HELP ME DECIDE ON THE MOST EFFECTIVE SOLUTION.



DESIGN #1  
(CONCEPT 1)

## STRENGTHS:

- SMALL & PORTABLE
- BUTTON & BASE ARE RUBBER; SOFT, COMFORTABLE TO USE
- STANDS STABLY
- MODERN & ELEGANT; SUITS PEOPLE ALL GENDERS AND AGE RANGE WITHIN THE AUDIENCE
- KID-FRIENDLY APPEARANCE & SAFE; SUITS HOUSEHOLD USE.

## WEAKNESSES:

- SHAPE OF BUTTON NOT EFFICIENT; REQUIRES MORE FORCE TO STAPLE PROPERLY

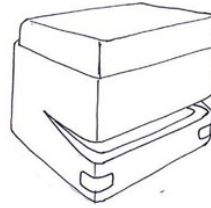

DESIGN #2  
(CONCEPT 2)

## STRENGTHS:

- FORM ENABLES PROPER FUNCTION
- SIMPLE GEOMETRIC SHAPE; STREAMLINED
- BALANCED & STABLE
- NEON STRIPES EXTREMELY EYECATCHING & MODERN; APPEALS TO YOUNG PEOPLE
- DOMINANT COLOUR IS BLACK → SUITABLE FOR MORE FORMAL OFFICE ENVIRONMENT

## WEAKNESSES:

- OLDER PART OF AUDIENCE i.e. AGED 40-50 MIGHT NOT LIKE NEON COLOURS AS THEY'RE TOO BRIGHT & YOUTHFUL FOR THEIR AGE.



DESIGN #3  
(CONCEPT 2)

## STRENGTHS:

- FORM ENABLES PROPER FUNCTION
- SIMPLE, STREAMLINED, CONTEMPORARY → SUITS OFFICE ENVIRONMENT
- STANDS STABLY; NOT TAKE UP MUCH SPACE
- SHAPE STANDS OUT FROM SIMILAR PRODUCTS.

## WEAKNESSES:

- AUDIENCE NEEDS TO BE NOTIFIED OF THE PROPER WAY TO USE IT. THIS WEAKNESS IS ACTUALLY INSIGNIFICANT.

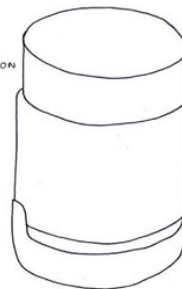

DESIGN #4  
(CONCEPT 1)

## STRENGTHS:

- SIMPLE FORM & COLOURS → MODEST AND ELEGANT; SUITS PROFESSIONAL ENVIRONMENT
- ROUNDED, RUBBER BASE → SOFT, COMFORTABLE TO USE

## WEAKNESSES:

- DOES NOT STAND OUT MUCH
- IF DROPPED ON THE FLOOR, IT ROLLS AWAY

- ▲ After exploring the functionality and form of her designs for a stapler, this student evaluated each design in line with the original design brief.

## REFINEMENT

After the development phase, the design concept that is most effective in fulfilling the requirements of the brief is selected. The question now raised is: What needs to be done to ensure that the final design fully reflects the needs outlined in the brief?

**Refinement** refers to finishing the most successful concept, and leads to the production of a **mock-up**. During this stage, the appearance of the final design is clarified and refined, and final decisions are made about elements such as colour or the most appropriate grades of materials and media that will be used. Methods of production are finalised at this stage; decisions are made about the most appropriate form of printing, presentation, construction or manufacture.

Refinement involves the implementation of selected elements, principles, media, materials and methods following the testing and evaluation of alternatives. This stage involves the final drawing together of ideas and concepts that fulfil the communication's need.

In your design work, refinement should be an opportunity to enhance and clarify the most appropriate design concept. After developing your initial ideas and testing the viability and appropriateness of the most appealing concepts, you will have selected the most appropriate concepts to proceed with. Refinement is the perfect stage for transferring your images to digital media and ensuring that elements such as colour and letterform are appropriate. You may also wish to test alternatives on the computer for the design of your final presentation.



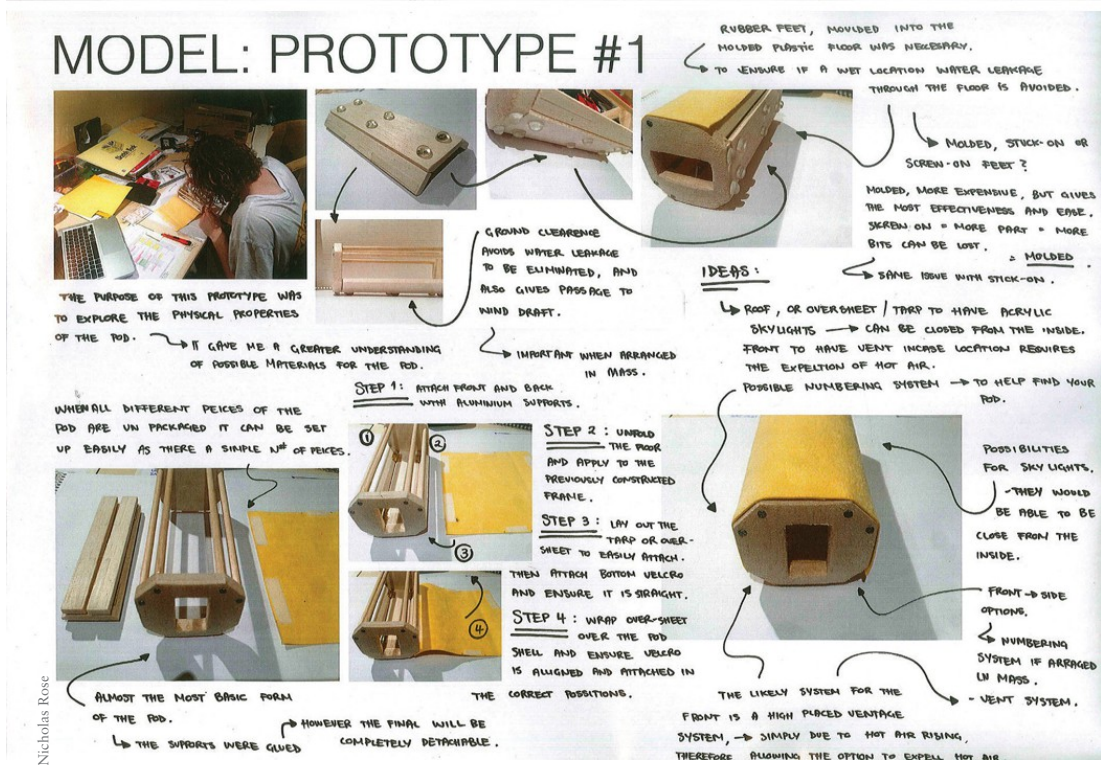
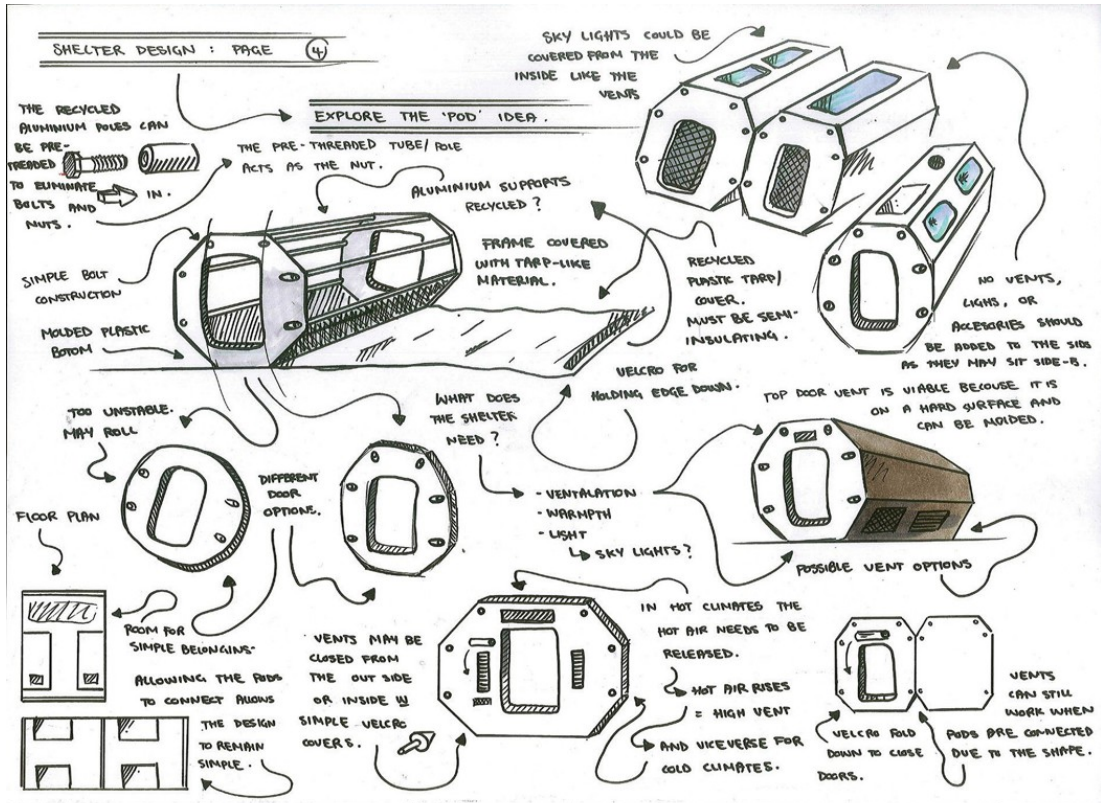

▲ In developing a concept for portable, emergency housing, this student used drawing and 3D construction to trail and test function, durability and aesthetics.

## DEVELOPMENT OF IDEAS VISUAL COMMUNICATION ONE

I CHOSE A BLUE SPINE AS IT WOULD CONCEIVELY MATCH MOST COLOURS ASPECTS OF THE VINYL SUCH AS THE SLIP AND PAPER - I THINK THE DOTS AND TYPE AS WELL

THE RED BACK COVER, JUTTAPOLES & CROPPED IMAGE TO THE LEFT AND TO KEEP A THE BRANCE OF THE IMAGE IS HELP WITH THE TYP - CROPPING

I DECIDED TO RE-USE THE COLOURS FOR THE SLEEVE AND JUTTAPOSE AGAINST A VIBRANT BLUE. I LIKE HOW THE RED DOTS CONTRAST AGAINST THE PICTURE

I WANTED THE COLOUR TO CONTRAST WELL AGAINST THE ALBUM FACES TO KEEP THE COHERENCE OF THE RECORD BEING ONE CATHING

I DO NOT LIKE THE SOLIDS WILL WITH COLOUR & TEXT

AS WELL AS THE SLEEVE FEELS WHITE THE RED PACKAGE

THE SLEEVE SIMILARLY FOLLOWS THE SAME CONCEPT IN THE FUTURE - COLOURS WITH DARK CONTRASTED SCENE IMAGES HOWEVER I PLACED THEM AT RANDOM PLACES IN SIMILAR AND WARMER SCENE AND FEELS THE DARKNESS

I WANT TO MAKE SURE THE COLOUR OF THE SPINE TO COHERENCE COME WITH OTHER COLOURS IN THE RECORD

USING A ROW OF CONTINUOUS IMAGES THAT ILLUSTRATE BOTH CHARACTERS AND THE PORTRAIT SHOTS, JUTTAPOSE WITH BRIGHTLY COLOURED MONTAGE BACKGROUNDS AGAINST A VIBRANT RED WALL. I DECIDED TO KEEP THE IMAGES THE SAME SIZE AND ROUGHLY SPACED TO KEEP THIS VISUAL - NOT A RED. I ALSO FEEL THAT THE STILL HOLDS A GREAT CHANGE BEING RAISED TO THE TOP

THINKING BEING A BIT JUTTAPOSE AGAINST RED AND YELLOW, FOLLOWS THE ALBUMS COLOUR CHANGE

## DEVELOPMENT OF IDEAS VISUAL COMMUNICATION TWO

**PERSPECTIVE OF BOX DIMENSIONS**  
I CHOSE TO DO A BOX AS I FELT THIS WAS A SLEEK WAY OF PRESENTING THE DISCS PACK AND TO HOLD AN INFORMATION

THIS BOX WILL WORK WELL FOR THE AUDIENCE AS IT WILL BE AMILLED TO THIS SIZE FOR MAIL - IT WILL WORK WELL TO OPEN AND TO BE USED. IT WILL BE LIGHT AND EASY TO USE

BY USING A COLOUR FOR THE INTERIOR OF THE PACKAGE, I FEEL IT WILL CONTRAST A MULTIPLE COLOURS

FEEL TO BE THE PACK

MAIN THE INFORMATION ASSESS AND PLACED AT THE BOTTOM TO BE VIEWED WITH THE RED SPACING OF THE LETTERS CREATED A FEEL OF THE UNCLE SAM'S STRIPES WHICH I LIKE HOW THE DESIGN IS

USING DOTS IN CORNERS OF THE PACK WITH COLOURS THAT CONTRAST WITH THE PACK DOES NOT WORK BUT I LIKE HOW THE DESIGN IS

IT FEELS LIKE THE BOX COULD BE EITHER BY LATER CUT OR ENGRAVED

RED PANELS THIS COULD MY WORK WELL AS IT IS STRONG AND RED, KEEPING IT ONE OPTION

MULTI COLOUR PANELS I DO NOT LIKE THE USE OF THE MULTI COLOURS AS I FEEL THEY CLASH TOO MUCH AND MAKE IT UNATTRACTIVE WITH OUTSTANDING COLOURS

BLUE PANELS AN ALL BLUE PANEL BOX COULD WORK WELL TO FOLLOW THE PRINCIPLE COLOURS AS WELL AS BEING ANIMATE AND ONE COLOUR

PLACING AROUND WITH THE SAME OF THE FACE AND LETTERING I FEEL THIS WOULD BE TO FILL IN THE COLOURS OF THE PACK, I FEEL THIS DOES NOT CONTRAST AS MUCH AS I FEEL TO IS AS THE BOX IS TOO WIDE, I WANT TO BE OPEN

INSTEAD OF USING THE PLACING AROUND WITH THE ALIGNMENT OF DOTS HAVE - NO THEM CONTRAST AND BE BALANCED IN THE MIDDLE OF THE PACK GIVES A LARGE SPACE AROUND IT, BUT THE COLOURS WOULD BE CONTRAST TO KEEP IT BEING - BUT AND IN WITH THE THEME, THE BOX INTERCONNECT WITH THE ALBUM

PLACING AROUND WITH THE CONTRAST OF SPACING BETWEEN LETTERS, I LIKE THE SIMILARITY OF HAVING THE LETTERS PLACED IN THE MIDDLE WITH A LARGE SPACE AROUND IT TO KEEP A COHERENT FEEL. I WILL CONTRAST FROM, I WILL CONTRAST FROM, I WILL CONTRAST FROM

▲ Pages showing the development of ideas. Note the annotations that explain the thinking behind the decision making.

## REFINEMENT OF IDEAS

INITIAL IDEAS = TOO BASIC ALSO GENERAL MAKE INTERESTING + INTERESTING

UPON TRIMMING THE DIMENSIONS I DECIDED TO ADD "SIDES" TO THE BOOK, WHICH ENABLED ME TO CREATE A PERFECT 90 DEGREE ANGLE OF THE BOOK = BEING AROUND PERFECTLY MAKING IT MORE CLEAN AND SUEK

I DECIDED TO MAKE THE PRESS PACK LIGHTER BECAUSE I FELT IT WOULD GIVE A GOOD BREAK BETWEEN THE HEAVY LOADED ALBUM & INTERLUDE. I ALSO GOT RID OF THE WIDTHEN ON THE TOP OF THE BOX TO MAKE IT MORE SMOOTH & EASY TO USE

THE EXTICIDUE OF THE PRESS PACK

I PLANNED AROUND WITH THE COMASITION OF THE BOX AND HOW BIG I WANTED IT TO BE PHYLIPHAM ETC.

I DECIDED I WANTED THE BOX TO BE 157 X 222 MM (SMALLER THAN A4, BECAUSE I WANTED THE PRESS PACK TO BE A COMFORT SIZE FOR THE HAND & FOR IT NOT TO BE OVER IMPRESSIVE)

UPON TRIMMING THE DIMENSIONS I DECIDED TO ADD "SIDES" TO THE BOOK, WHICH ENABLED ME TO CREATE A PERFECT 90 DEGREE ANGLE OF THE BOOK = BEING AROUND PERFECTLY MAKING IT MORE CLEAN AND SUEK

I DECIDED TO MAKE THE PRESS PACK LIGHTER BECAUSE I FELT IT WOULD GIVE A GOOD BREAK BETWEEN THE HEAVY LOADED ALBUM & INTERLUDE. I ALSO GOT RID OF THE WIDTHEN ON THE TOP OF THE BOX TO MAKE IT MORE SMOOTH & EASY TO USE

## REFINEMENT OF IDEAS

### VISUAL COMMUNICATION ONE

CREATING THE ALBUM COVER & MANIPULATING PHOTOS - PROCESS

UPON FINISHING THE BACKGROUND, I DUPLICATED THE LAYERS AND CREATED A SHARP RED FILL IN THE LAYER BELOW IT. THIS ENABLED ME TO REMOVE ANY FRAGMENT OF THE IMAGE I DESIRE

I THEN USED THE LASSHO TOOL TO SELECT THE DESIRED AREA WHICH I THEN CUT OUT OF THE IMAGE, MAKING A RED BACKGROUND ENABLED ME TO HAVE A COMPLETE FILLED & SAME COLOURED IMAGE.

I THEN USED THE BRUSH TOOL TO BLEND THE COLOURED BACKGROUND AGAINST THE PHOTOGRAPH. I ALSO USED THE "LAYER" TOOL TO LIGHTEN THE CONTRAST OF THE BACKGROUND IN ORDER TO MAKE THE IMAGE "POP"

← I FOUND THE TYPE "CONTROL" TO BE TOO BOLD AND OVER BURSTING WHICH BROKE THE BALANCE OF THE MESSAGE. SOME THAT WOULD BE CUT OUT.

← I THEN USED THE SELECTION TOOL TO MAKE THE OUTLINE OF THE FRAME, I THEN USED THE BRUSH TOOL TO FILL THE BACKGROUND

← I THEN USED THE "BLUR" TOOL IN ORDER TO BLEND THE COLOURED BACKGROUND AGAINST THE PHOTOGRAPH. I ALSO USED THE "LAYER" TOOL TO LIGHTEN THE CONTRAST OF THE BACKGROUND IN ORDER TO MAKE THE IMAGE "POP"

← I THEN KE PASTED THE CUT AREA, WHICH I THEN MULTIPLIED AND LAYERED IN AN EQUAL DISTRIBUTION IN ORDER TO CREATE A COHESIVE BALANCE. I THEN USED THE ERASE TOOL TO MAKE THE IMAGE SQUARE LIKE AN "LIP"

▲ Finalising a **prototype** and executing the final editing of his photographs using CAD were methods of refinement applied by this student.

Like every other phase of the design process, refinement is undertaken with reference to and consideration of the design brief. If, on reflection, a concept developed at this late stage does not fit with aspects of the brief, then you may need to refer to the development stage to address any shortcomings.

## MOCK-UPS AND PROTOTYPES

A mock-up or prototype of a design is a 'rough copy' of the design. It provides the opportunity to test the final product as it will appear after production. If this stage proves successful, the designer will proceed to the final production. If the mock-up is tested and found not to fulfil the needs of the brief, the designer will return to the design process and either refine the concept further or scrap it and start again.

Mock-ups come in all shapes and sizes; they can be 2D or 3D. A mock-up can be a scale model, which is

common in architectural and product design. Set and theatre designers regularly create models of sets, which enable others involved in the production to visualise the use of props, lighting and the position of actors before the actual set is constructed.

The use of design technologies including CADD and 2D or 3D printing methods enables small scale prototypes or computer-generated mock-ups to be used in evaluating graphic designs, products, interiors and buildings. Software can simulate a three-dimensional 'walk-through' of a building or other structure and may include all relevant details such as lighting, decor and materials.

Prototypes and mock-ups are often presented to the client or to a select group of end users, as part of an evaluation process. This provides the opportunity for modifications to be made at a stage where changes are affordable and achievable. This stage is often the final opportunity for evaluation before the production process begins.

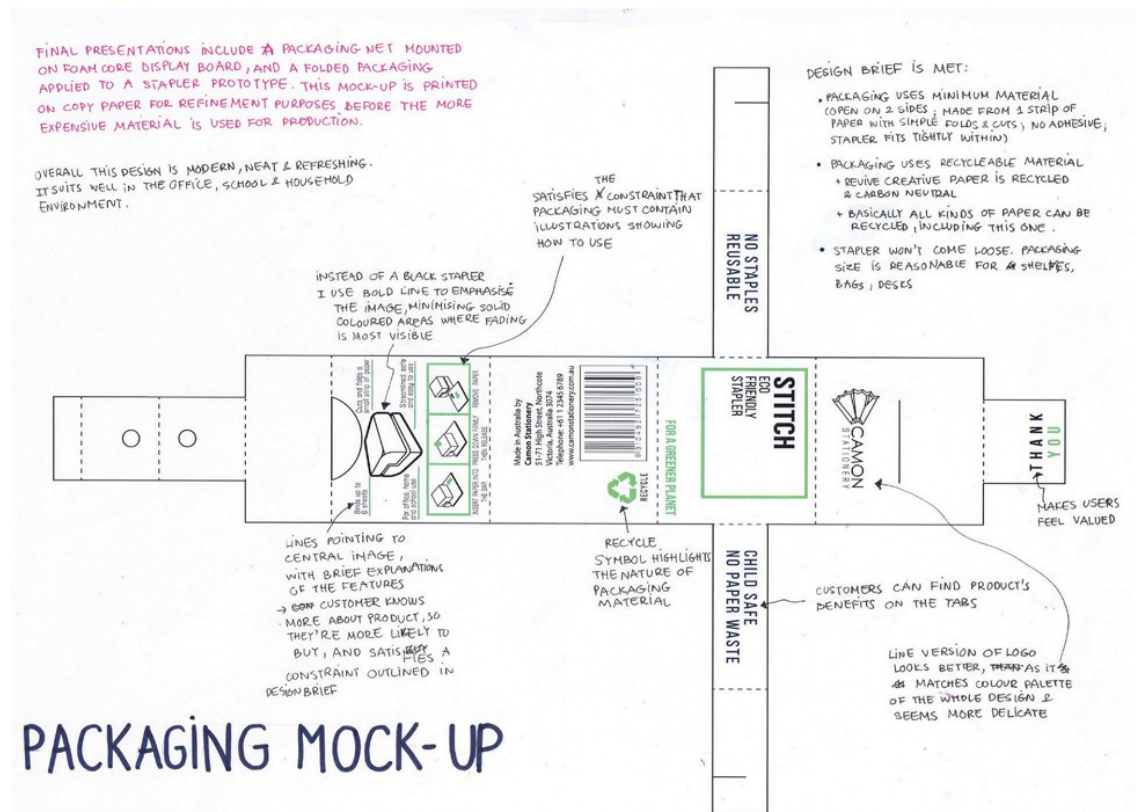

▲ This student created a prototype of her packaging design during the refinement stage. She was able to evaluate the suitability of the scale in featuring the final surface graphics and text.



Nhu Duong

▲ The final packaging and product model.

Mock-ups and prototypes are important for both professional and student designers in communicating ideas. They allow non-designers

to visualise design concepts in a familiar three-dimensional way. In property development, this has become a marketing tool: potential buyers can view a house or apartment before it is built, by observing models through 3D software in addition to more traditional two-dimensional architectural plans.

Use the refinement stage to maximise the quality, impact and appeal of the applied drawing methods, media, design elements and principles. The refined concepts, along with succinct annotation, should clearly communicate your design intentions and meet the brief.

Refinement of ideas can involve:

- + selecting the final concept
- + finalising the choice of materials, design factors and representations
- + refining the application of the chosen elements and principles of design
- + ongoing reference to the brief to ensure the design is accurate
- + creating a mock-up or prototype for final evaluation.

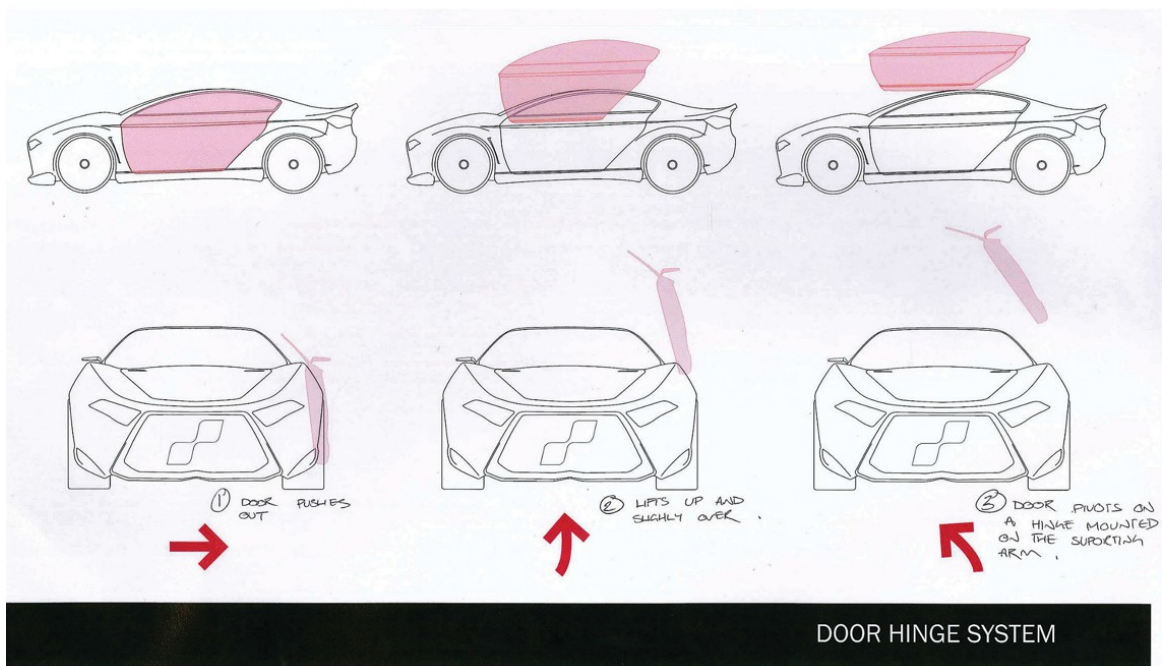

Tom Grech

▲ Final details of the vehicle design, such as door functionality, were addressed using an effective diagrammatic representation of the student's design idea.

# EVALUATION

It is essential to evaluate design ideas and assess how effectively they meet the needs of the design brief and solve the original design problem. Evaluation occurs **throughout** the design process to ensure that the requirements of the design brief are being met. The costs and processes involved in the production of most design products are often expensive and complex, so it is essential that the designer identify strengths and weaknesses in a design before final production commences. The cost of destroying final products due to design flaws is prohibitive and must be avoided at all costs.

Throughout the design process, the designer continues to evaluate the direction of the design solution within the parameters of the design brief. Regular reflection on the progress of the design is essential to ensure that it meets the needs of the design brief and addresses/solves the original design problem.

In the later stages of the process, a mock-up, model or draft of the design concept is used to test compatibility with the brief.

When evaluating your own design ideas, ask yourself whether the expectations of the client and the needs of the end user have been addressed. If not, return to the developmental stages and make the appropriate adjustments to some of your concepts. If your preferred design concept covers the design problem, then proceed with refining it.

The purpose of evaluation is:

- + to ensure that the design is in line with the original design brief
- + to inform decisions about directions taken during the design process
- + to develop a mock-up or draft to test the suitability and effectiveness of the final concept or to provide the client with a preview of the final design
- + to provide an opportunity for change and alteration throughout the design process.

PRESENTATION 1: DEVELOPMENT OF CONCEPTS

CHECKLIST AND RANKING

Criteria	Option 1	Option 2	Option 3
Does this design approach the target audience?	1	2	3
Does this design depict a brand?	2	3	1
Does this design depict the cultural environment?	2	3	1
Is this suitable to both the space and budget?	1	2	3
Is this modern and up-to-date?	2	1	3
Does it depict a professional company?	2	1	3
Does this design radiate luxury?	2	1	3
Is the design unique?	1	2	3
Does this clearly identify Jesho Beauty?	1	3	2
Overall aesthetics of the logo and applications?	1	3	2
TOTAL	15	21	24
OVERALL RANKING	1	2	3

THIS DESIGN RANKED NUMBER 1, HAVING SCORED THE LOWEST TOTAL SCORE. THIS DESIGN WAS CONSISTENTLY FOUND TO BE THE DESIGN THAT BEST MET THE NEED IN THE CRITERIA QUESTION. WITH THIS ANALYSIS AND THE PMI CHECK, THIS TOP DESIGN WAS CHOSEN TO BE REFINED.

PRESENTATION 1: DEVELOPMENT OF CONCEPTS

To help decide on the final option for the brand identity design for Jesho Beauty, a PMI analysis was conducted to compare the three designs and choose the one that best meets the needs of the client, as specified in the design brief.

Also, each of the designs were ranked next to each other to a checklist of criteria taken from the design brief. For each criteria, the designs were given a number (1, 2 or 3 - one being the design that best meets the need specified) then these numbers were added up for each design. The design with the lowest sum of these numbers is the design that best meets the needs of the client. This analysis clearly shows how successfully the designs meet the needs of the client, compared to the other two designs.

PMI ANALYSIS

	Option 1	Option 2	Option 3
<b>+</b> PLUS What works well in this design?	- Modern and contemporary design - Simple and balanced image - Logo works well across the range of applications	- Very luxurious gold and black colour scheme - Image allows for interesting cropping within the applications - The strong contrast between the image and the dark background draws the eye to the image first, creating in logical hierarchy	- Soft and calming feeling given by the watercolour - Unique due to the hand generated typography
<b>-</b> MINUS What doesn't work well in this design?	- I don't like this hue of green as much - this will need to be adjusted (maybe more blue/teal) - Grey also may need to be a bit lighter to suit the day spa context	- The black background seems very heavy and possibly not as suited to a day spa	- Because the typeface of 'Jesho' is hand drawn the typography on the other applications is constrained to the one typeface family - The typeface does not work as well across the applications as it does in the logo (in capitals) - this would need to be changed
<b>?</b> INTERESTING What's interesting about this design?	- Similar organic shapes to option two but this is very suited to the design brief and the context of the day spa - This design works well across the applications	- Could use gold foil when printing the business cards and metallic thread in the embroidery of the dressing gown - However, this would not be possible for the uniform, door signs, shopping bag, not pen - Could make a gold leaf texture to be scanned and applied to the printed designs	- Contemporary take on a traditional hand drawn logo - The watercolour on the applications is not the right shade and would need to be changed so that it is the same as the logo - The brand identity is not explicit across the applications - the watercolour is enough to be them all in together

Emily Wooley

▲ Design thinking techniques can assist in evaluation and decision making. This student used several techniques to help evaluate the most effective and relevant directions for her designs. For more on design thinking techniques see Chapter 9.

In evaluating your own design work you will apply critical and analytical thinking to determine decision making and design directions.

As in a professional design environment, the most common design evaluation tools that you will find helpful in your own work are mock-ups and models/prototypes that will allow you to evaluate and test your final concept. These tools allow you (and others) to examine and judge the effectiveness of the concept in line with the design brief. These may be three-dimensional or digital representations.

These drafts should be as close in appearance as possible to the final deliverable. However, the materials that you choose to use may be different. Plain paper, for instance, may be used in the mock-up as an alternative to more expensive printing paper with a special coating. You may choose to create an entirely digital model to assist in making decisions about final colours, textures, forms and materials. The scale of a model will most likely differ from the plans for production and this is often a practical consideration in a school setting.

The effectiveness and suitability of the draft will determine if and when production goes ahead. It is essential to have a critical eye when judging the success of a design concept at mock-up stage. Be objective and, if necessary, use the opinions of others to gain feedback.

If your evaluation is a success, then proceed to the production stage. If not, it means quite literally going back to the drawing board. An unsuccessful design idea can usually be traced back to a poor understanding of the original design brief.

## TIPS FOR EVALUATION



Benchmark your work against the design brief. List the key components of the brief and ensure that you have covered them in your book. There are a number of helpful methods you can apply. A simple visual method is to use multicoloured Post-it notes that indicate parts of the brief, for example blue for audience, green for constraints, etc. Stick the notes on the pages of your book that show where you have addressed these aspects. This will give you an immediate visual glimpse of any gaps.

Use checklists to mark off each aspect of the design brief (and of the assessment criteria).

Ask a friend or family member to look through your folio and see if it tells a 'visual story'. Ask them to look out for any gaps in the process.

Show the client. Ask for direct feedback and record comments and suggestions. Reflect on these in your annotations.

Return to the 'scaling' technique and apply your final design next to similar products/concepts. Did you achieve the positioning you required?

MAKING THE MODEL:—

HERE I HAVE MEASURED AND CUT THE LENGTHS. I TAPED THEM TOGETHER WITH MASKING TAPE TO MAKE SURE THE SIZE AND PROPORTIONS WERE ALL CORRECT.

SHORTENED THE LENGTH HERE TO BE IN THE CORRECT SCALE → THE WIDTH OF ONE BED (SHOULDER TO SHOULDER)

AS THE UNIT HAS A LOT OF WINDOWS AND IS QUITE SEE THROUGH BY OBSERVERS FROM THE OUTSIDE → SO I DECIDED TO PUT IN THE DOOR AND WALKWAY ON THE INTERIOR.

BY STICKING THE WINDOWS IN WITH DOUBLE SIDED TAPE IT STRENGTHENED THE THIN BITS OF WOOD. I ALSO DECIDED TO MAKE ONLY 2 WINDOWS ON THIS SIDE, AN OTHERWISE IT WOULD LOOK FUNNY.

I PUT IN THIS FLOOR FOR THE SAME REASON AS THE DOORS → SO THAT IT LOOKS GOOD FROM THE OUTSIDE AND THE INTERIOR LOOKS ROUGHLY AS IT SHOULD WITHOUT TOO MUCH DETAIL.

THIS DOOR BIT TURNED OUT TO BE THE PERFECT SIZE → CAN SLIDE IN AND OUT BUT IS SMALL AND DOESN'T MOVE PROPERLY.

DOING IT IN THREE PARTS MEANT IF ONE WAS MESS'D UP → IT DIDN'T AFFECT THE WHOLE THING.

AT THIS POINT I WAS REALLY HAPPY WITH EACH PART AND DECIDED TO GLUE THEM.

TO MAKE SURE EACH SIDE WAS AT EVEN HEIGHTS I PUT AND GLUED THEM WHILE ON TOP TAPE.

AT THIS POINT ALL I HAD TO DO IS STICK THE LEGS ON, AND ADD SOME FINER DETAILS.

... CONTINUED:—

HERE I ADDED A DOOR → MAKING THE HANDLE WAS VERY TROUBLESOME. I STUCK THE DOOR ON WITH MASKING TAPE SO IT COULD MOVE.

I MADE THE STRIPS BUT DIDN'T STICK THEM ON BECAUSE I STILL HAD TO HANDLE IT A LOT AND I DIDN'T WANT TO BREAK IT. BY ADDING THESE DETAILS, THE MODEL REALLY CAME TOGETHER.

I ROUGHLY MEASURED THE LEGS AND ALTERED THEIR HEIGHTS ACCORDINGLY → TILL IT SAT LEVEL.

HERE IS THE FINISHED MODEL, WHICH I WAS INCREDIBLY HAPPY WITH.

TO MAKE THE SECOND LAYER, I CUT OUT ANOTHER FULL SHEET AND CUT OF ONE CORNER BUT FOR THE OTHERS I JUST HAD ONE RIGHT ANGLE WITH SOME CURVES.

I DEBATED AS TO WHETHER TO PUT A FOURTH LAYER ON, AND I DECIDED I LIKED THE ASYMMETRICALITY OF IT THAT KIND OF ENLARGED IT OUT.

FOR THE CARDBOARD BASE, I INITIALLY MEASURED 500 x 500 MM BUT UPON SITTING THE MODEL ON THIS, I FOUND IT WAS TOO SMALL FOR WHAT I ENVISIONED. I DIDN'T WANT IT TO BE TOO CRAMPED AND FOR PEOPLE TO BE ABLE TO FULLY VISUALISE THE UNIT IN AN OPEN SPACE. THIS ALSO MADE THE PROCESS BETTER AND GAVE ME THE ABILITY TO HAVE MULTIPLE CONTOURS OTHERWISE IT WOULD HAVE LOOKED CRAMPED AND THE CONTOURS STEEPER. SO I EXTENDED IT TO 700MM X 700MM.

EVALUATION:—

I WAS/AM VERY PLEASED WITH THE FINAL MODEL. IT IS WELL FINISHED ALTHOUGH A FEW ROUGH BTH MISTAKES ARE EVIDENT AND CAME WITH MY INEXPERIENCE WITH MODEL MAKING AND WORKING WITH WOOD. REGARDLESS, THE FINAL PRESENTATION LOOKS JUST HOW I IMAGINED AND REALLY BEINGS TO LIFE THE UNIT I DESIGNED AND PREVIOUSLY HAD JUST ON PAPER.

I DIDN'T HAVE TIME TO PUT TREES (ORNS) ON TO THE MODEL BUT FORGIVING THIS ASPECT DIDN'T HAVE A HUGE IMPACT ON THE FINAL MODEL. I MIGHT PURCHASE SOME FIGURINES TO SHOW SCALE INSTEAD.

▲ This student documented the development of a scale model with photography. Each stage of the construction process was annotated, and illustrated the evaluation process that occurred at every step.





# RESOLUTION AND PRODUCTION

The final visual communication is produced only after extensive evaluation of the preferred design concept. Production can vary from the printing of 500 single-colour business cards to the construction of a city building, and is often expensive.

The general nature of the deliverable is usually defined in the design brief, but the design process often allows room for creative interpretation and decision making about the most appropriate graphical product to meet the original need. Some of the most remarkable

or exciting designs are those that have been developed within a very flexible brief for a client willing to take an innovative and even risky design approach.

Designers can be involved in the production of diverse designs, making it difficult to define the boundaries of the final product. Production methods can be as varied as the design products they produce. They might range from the printing of a durable waterproof logo decal for an ocean-going yacht, to the creation of a three-dimensional type designed to sit on top of a hotel, to the production of injection-moulded plastic forms for a child's toy.

It is possible to categorise, by area, just some of the final presentations that might be produced.

Presentation format	Examples
<p><b>Communication design</b></p> <p>These presentations provide information for the viewer and can convey complex information and messages clearly. They can be used for the advertising, promotion and depiction of products and services.</p> <p>The application of design factors including the elements and principles of design are central to the effectiveness of these designs, and the application of media and materials is diverse. Presentations may take a two-dimensional or three-dimensional form.</p> <p>Designs may vary from a corporate logo to the signage for the Olympic Games, from a map of bicycle paths to a multipage interactive website.</p>	<ul style="list-style-type: none"> <li>Maps</li> <li>Packaging</li> <li>Symbols</li> <li>Advertising</li> <li>Charts</li> <li>Logos</li> <li>Illustrations</li> <li>Brochures</li> <li>Freehand drawing</li> <li>Posters</li> <li>Diagrams</li> <li>Publications</li> <li>Graphs</li> <li>Infographics</li> <li>Clothing</li> <li>Signage</li> <li>Exhibition displays</li> <li>Multimedia</li> <li>Motion graphics</li> </ul>
<p><b>Industrial design</b></p> <p>These presentations conform to rules and conventions that define the arrangement of images and the presentation of visual data. They may convey two-dimensional and/or three-dimensional information.</p> <p>Final designs may be manufactured from a diverse range of materials and involve combinations of design factors including sustainability, materials and elements and principles of design.</p> <p>Products can vary from small-scale domestic items to automotive design, from fashion to aircraft.</p>	<ul style="list-style-type: none"> <li>2D and 3D drawings</li> <li>Engineering drawings</li> <li>Concept presentations</li> <li>3D scale models</li> </ul>
<p><b>Environmental design</b></p> <p>These presentations present information about the construction of designs within a built environment. The presentation of information may be two-dimensional or three-dimensional. The final production of the finished product is usually three-dimensional.</p> <p>Some environmental designs are purely conceptual and are designed to inspire ideas rather than conclude with a finished product. Designs can vary from small residential projects to large apartment complexes, from courtyard landscaping to the design of a space station.</p>	<ul style="list-style-type: none"> <li>Architectural drawings</li> <li>3D scale models</li> <li>Multimedia</li> <li>Maps</li> <li>Diagrams</li> <li>Concept presentations</li> <li>Plans</li> <li>Digital 'walk-through'</li> </ul>

In creating your own final design deliverables, practical considerations must be considered, as these will influence your decisions on the form of the final design. Practical issues to consider may include choice of materials, scale and form of the final presentation, as well as the presentation space and location.

When it is not feasible for you to actually manufacture the design you have designed, a concept presentation may be the most appropriate means of communicating the final concept. Concept presentations present visual information about

what the final product would look like were it to be produced. A concept presentation may include a range of graphical representations, which explain the features, and appearance of the final design.

A combination of the requirements of the original design brief and the available resources determine the production of your design concept. It is an opportunity to respond creatively and to present your thoroughly researched and developed work. Your work may be assessed on a range of criteria including the imaginative and creative response you bring to the task.



▲ This student created a concept board as a final visual communication to explain the atmosphere and ambiance of a proposed interior space. The board uses collage, drawing and the student’s own photography to illustrate details about the appearance and features of a nightclub/bar design.



▲ Computer rendering and scale model presented as final design deliverables. The design brief required the design of a demountable housing option for homeless people in urban areas.

# A PITCH AS AN EVALUATION TECHNIQUE

A common part of the professional design landscape, the pitch is a meeting between client and designer during which the designer presents design options that ideally fulfil the needs of the client. In a professional setting, the pitch may be a face-to-face meeting, an online interaction or a discussion and will usually involve the presentation of visual material that explains the designer's vision and proposed solution to a design brief.

In VCE Visual Communication Design, the pitch is designed as a means of presenting the design ideas and solutions that have been developed and refined over the course of the design process. It is an opportunity to explain to a relevant audience such as client or audience, the journey from brief to the final design concepts.

As an evaluation tool, a pitch provides an opportunity to gauge the success of a design. Used before the final resolution of a design, it can help to refine and finalise aspects that may influence success.

## KEY ELEMENTS OF A PITCH

- + Clear connections between design brief and final design concepts.
- + Demonstration of strong understanding of the original communication need.
- + Empathy and understanding of the audience/end user.
- + Deep understanding of the creative, reflective and critical thinking processes behind the final design decisions.
- + Openness to advice and suggestions, even when the resolution seems otherwise complete.

### TIPS FOR A PITCH



Your pitch is an opportunity to convey your ideas to the client or audience and is a chance to showcase your thinking and design skills. It is essential to use the appropriate Visual Communication Design terminology that you have developed through the coursework.

When referring to your design process, make use of terms that are appropriate and suited to the point you are trying to make.

### CHAPTER RECAP



- 1 Create a simple diagram, using your own visuals, to explain the design process.
- 2 What is the difference between quantitative and qualitative research methods?
- 3 Suggest how design ideas could be evaluated at the following stages of the design process: generation of ideas, development of ideas, creation of a mock-up.
- 4 Suggest four questions that might be used to stimulate 'predictive' and 'reflective' annotations.
- 5 What is the purpose of the design brief?
- 6 Describe key decisions that might be made during the refinement stage of the design process.
- 7 In designing a music festival poster, what might be methods of research undertaken by a designer?
- 8 What information might be gathered from researching existing and past designs?



# DESIGN THINKING

CHAPTER

9

---

## In this chapter:

+ What is design thinking?.....	205
» Creative thinking .....	205
» Critical thinking .....	205
» Reflective thinking .....	206
+ Design thinking techniques .....	206
» Creative thinking .....	206
» Critical thinking.....	210
» Reflective thinking.....	215

## Learn the language

brainstorming

critical thinking

evaluation

creative thinking

decision making

reflective thinking

You will find many examples of thinking tools and templates in Chapter 1 of *Nelson Visual Communication Design VCE Units 1–4 Workbook, Edition Three*.

---

## WHAT IS DESIGN THINKING?

Design thinking is a term coined to describe the application of tools that are familiar to designers to a wider context. Design thinking is a methodology of creative problem solving that is used increasingly to initiate, explore and realise effective solutions to problems of all shapes and sizes. Increasingly, the term is used in professional and educational contexts that are not related to design disciplines. It is a recognition that the creative processes applied in design can be applied to solving complex problems in diverse educational, professional and cultural contexts.

In Visual Communication Design, we are able to utilise a wide array of design thinking tools to assist in our creative process. Techniques that facilitate deep thinking, meaningful analysis and targeted decision making are an essential part of the design process. Design thinking may occur at any stage of the generation, development and refinement of a design concept.

In the VCE Study Design, design thinking incorporates creative thinking, critical thinking and reflective thinking.

## CREATIVE THINKING

This requires a curious, open-minded, flexible, divergent, explorative, investigative approach.

### Examples of creative thinking

**Creative thinking** is the generation of a wide range of different design ideas. Creative ideas are often prompted by researched directions but are not inhibited by a filter. Ideas generated using creative techniques may vary widely and encompass abstract and unusual ideas. An architect may use sketches to explore innovative and experimental forms in the early stages of a design. The renowned architect, Frank O. Gehry uses sketching to devise creative ideas for his clients. The sketches are often loose, fluid and experimental. Gehry's spontaneous drawings are a fine example of drawing as a highly effective creative thinking tool.

- + Creative thinking uses prompts from research or sources of inspiration.
- + Creative thinking is unconstrained.
- + Creative thinking asks, 'What are the possibilities?'

ISBN 9780170401784

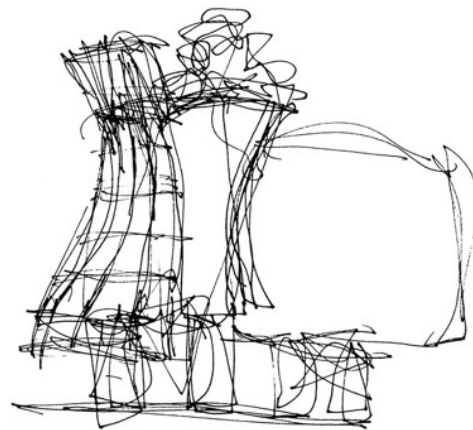

Alamy Stock Photo/United Archives GmbH

▲ Sketch by architect Frank Gehry.

## CRITICAL THINKING

This requires questioning, clarifying, planning, analysing, examining and testing information and ideas.

### Examples of critical thinking

**Critical thinking** is the development of concepts and ideas. Practical thinking tools that compare, contrast, evaluate and question the effectiveness of design ideas are at the core of critical thinking. Tools are varied and often suited to a designer's decision-making requirements. The use of matrices such as 'Plus, Minus, Interesting' or the experimental SCAMPER, enables different ideas to be considered or discarded, expanded or narrowed. Communication designers often use critical analysis of designs to determine the suitability of a concept; they may assess factors such as legibility, aesthetics and the clarity of a visual message. The significant rebrand of the Google logo in 2015 was a good example of a critical thinking approach to decision making.



Google

Nelson Visual Communication Design VCE Units 1–4

- + Critical thinking assists in decision making.
- + Critical thinking is often defined by the parameters of the design brief.
- + Critical thinking asks, 'What direction suits the brief/audience/client need?'

## REFLECTIVE THINKING

This requires a metacognitive approach, seeking and considering feedback, reflecting on progress and processes, making links and connections with broader issues and the work of others.

### Examples of reflective thinking

**Reflective thinking** occurs throughout the design process. Like creative and critical thinking, reflective thinking is about making decisions regarding the direction of a design. Usually, reflective thinking occurs after a design decision has been made; it is tested, evaluated and questioned. Judgements are made in relation to how well a concept meets the original needs of the design brief. Reflective thinking may be undertaken by a designer, the client or members of the target audience. The focus of this thinking tool is to judge what can be learnt from the design experience or design outcome.

A product designer might use reflective thinking to evaluate the ergonomic properties of a new design. Their analysis may involve comparing the feel and function of the product to other competitors' products.

- + Reflective thinking recognises the strengths and weaknesses of a design concept.
- + Reflective thinking is more complex than 'this or that', 'either or...' solutions.
- + Reflective thinking asks, 'What have I learnt from this outcome? How might I use that learning to progress with this task, or future tasks?'

# DESIGN THINKING TECHNIQUES

## CREATIVE THINKING

Creative thinking occurs throughout the design process but it is often most evident in the early generation phase. It manifests in the application of small, stimulating tasks that tap into the imaginative resources of your mind. These tasks are designed to exercise your brain or to help expand on an idea that needs a bit of a push.

Creative thinking and **brainstorming** is about quantity rather than quality and the aim is to generate lots of ideas that can be sorted through to identify potentially relevant design directions. The focus is on possibilities and the creative thinking that it inspires is open, non-judgemental and imaginative.

Although many of the techniques shown here are word based, they don't have to be. All of the examples in this chapter can also be used with sketches alone or in combination with text.

### Concept maps

Concept maps are visual tools used to create thematic structures. Concept maps are quick and easy to review – just a glance will organise and identify connections and relationships between ideas. Compared to conventional notes, a concept map engages more of the brain in the process of connecting facts and ideas.

A complete concept map will have main topic lines radiating in all directions from the central subject. Subtopics, themes and ideas will branch off these, like branches and twigs from the trunk of a tree. You do not need to worry about the structure produced – this will evolve of its own accord.

### LINK: OXO

OXO products are designed for function and comfort but the company's blog features articles that reflect on unsuccessful projects such as its bagel cutter, alongside its many successful and iconic products. The OXO website offers insights into the role of reflective thinking in a professional context. You can link directly to it via <http://vcd.nelsonnet.com.au>.



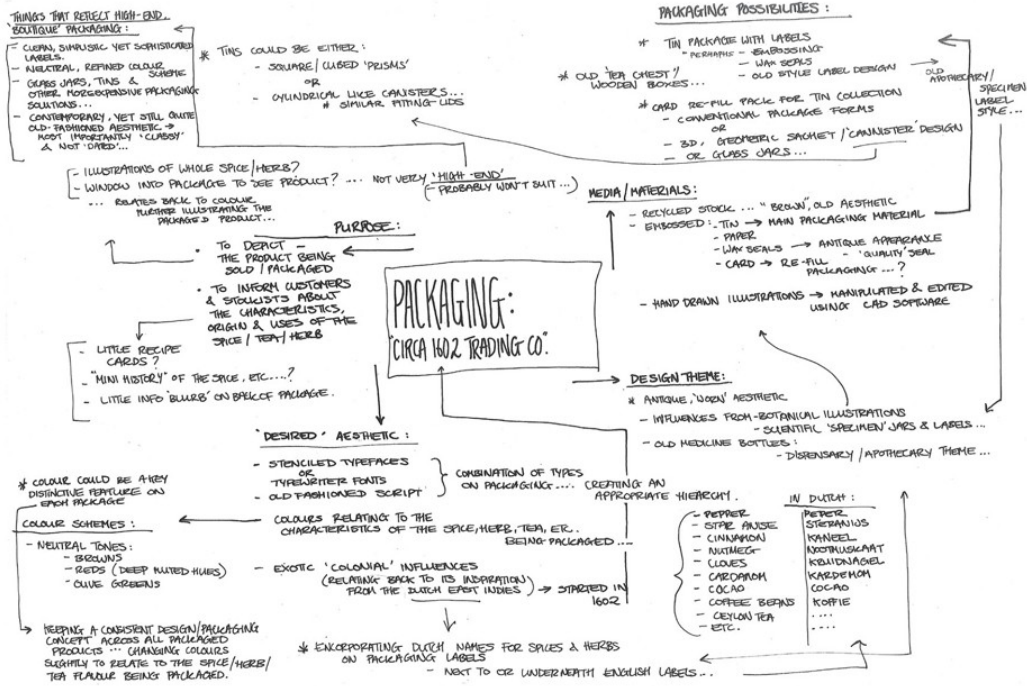

Johanna Schreiner

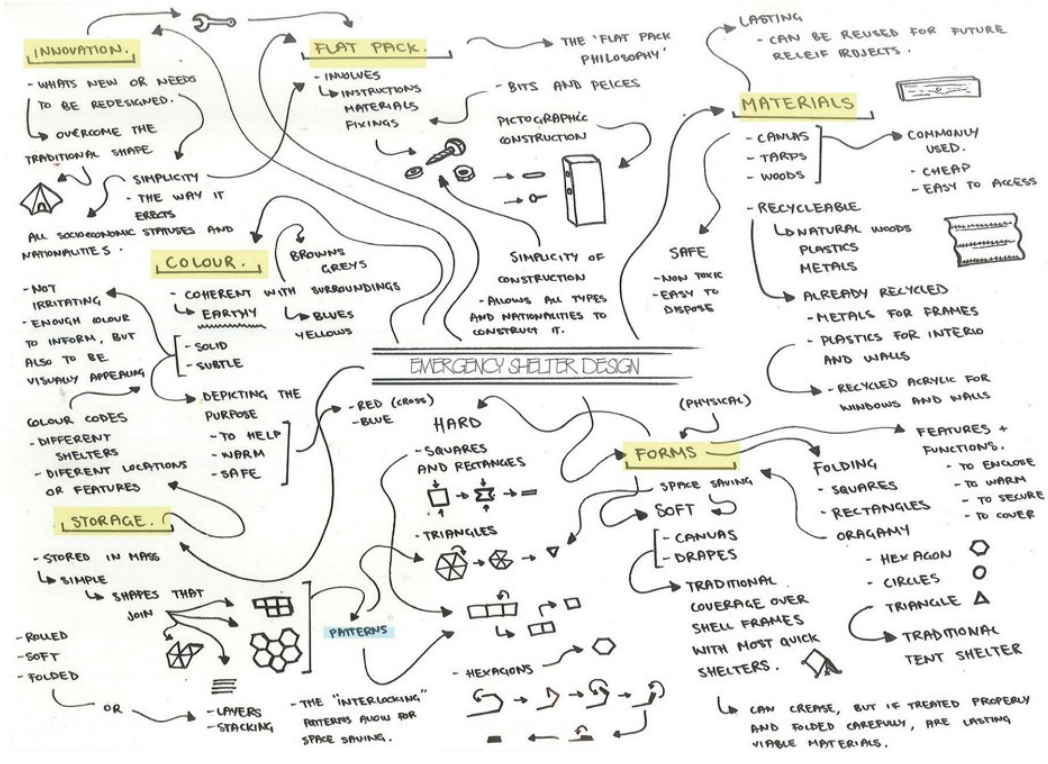

Nicholas Rose

▲ Concept maps do not have to use words alone. This student used a combination of text and small images.



**QUICKVID: CONCEPT MAP**

Watch how to create and use a concept map. Go to <http://www.nelsonnet.com.au> and log in using the code at the back of your book. Select this title, click on Resources and go to page 208 to watch the video.

## Design personality

A unique approach to stimulating the direction of a design, particularly if it has become stale or stuck, is to create a personality for the product or space in question. Imagine your design as a person and give it a creative name that captures its personality, for example 'Greta' or 'Marvin' or 'Tiffany'. Think about the design as a person and describe its personality traits; is it conservative? Outgoing? Dynamic? It may sound silly to do so, but attaching a persona to a product design can help to make decisions about what characteristics, design elements and features might be applied!

## Random words

A popular brainstorming tool involves selecting a random noun from a dictionary or thesaurus and finding a link with your theme or topic. In the design of a corporate logo, for instance, the random word 'bird' might be used to trigger ideas for a high-flying, progressive identity.

The subsequent brainstorming may be as follows.

- + Bird – bird flight – streamlined bird flying upwards.
- + Bird – bird's-eye view – overview of area below.
- + Bird – flock of birds – images of birds in the distance showing future planning/thinking.

Although an unusual method, the random word technique can be helpful when ideas don't flow. The method requires an open mind but the results will be fresh and can invigorate stale ideas.



▲ Random word cards.

## Visualisation drawing

Visualisation of ideas through drawing is a great tool for creative thinking. See page 62 for more information.

## Word lists

Making a list of words and phrases associated with the design problem is a good starting point. This simply requires you to write as many words as possible that are related directly or indirectly to the contents of the design brief. The idea of a word list is to forget about what might be relevant or irrelevant at this stage and just get as many words down as possible. When you think you have enough words, pick out the most promising words and develop them further. By taking one concept from the first list and expanding it into a sub-list, the ideas become more specific and can lead towards initial sketches.



Olivia Rose

▲ A word list that shows brainstorming of ideas. The student also uses the process to undertake critical thinking through annotation.

### Starting template for a word list

<p>Where will the design be located/used? List all of the possible locations and uses.</p>	<p>Who uses or sees the design? List every person or group that may come into contact with the design.</p>	<p>What does the design need to do/achieve? List all of the possible functions that the design could achieve.</p>	<p>What features might the design include? Be creative in listing every possible feature; practical or not. There are no right or wrong answers.</p>	<p>How will the design be distinctive? What could be done to the design to ensure it stands out?</p>
--	--	---	--	--

## CRITICAL THINKING

Critical thinking assists in making informed decisions. It allows for the brief, audience, research and other factors to be added into the decision-making mix. This approach encourages experimentation and testing of creative ideas. Concepts are critically evaluated and modified, enhanced or discarded as required.

### Affinity diagram



An affinity diagram is a method of organisation often used by creative teams and project managers to sort brainstormed ideas into groups of related concepts. Brainstormed ideas are written onto cards or added to chart software, then the relationships between the ideas are identified and grouped into like areas. Ideas are sorted into groups that have an 'affinity' with, or relationship to one another.

Affinity diagrams are highly visual and can be created manually using coloured Post-it notes or digitally using chart creation software. Colour coding is an integral part of the process as it helps to identify similar themes and ideas. Once formed into lists or groups, each idea can be prioritised to the top or bottom of the list. Ideas and concepts can be moved, removed and reorganised until a strong design direction is identified.

### Russian doll

Russian doll is a technique that 'splits' parts of a design problem into different attributes, which can lead to new and unexpected ideas. As in any technique that is focused on creating unfiltered ideas, there is no right or wrong dissections of the initial 'doll'. Every one will split ideas into different attributes. The aim of this technique is to 'unpack' possibilities!

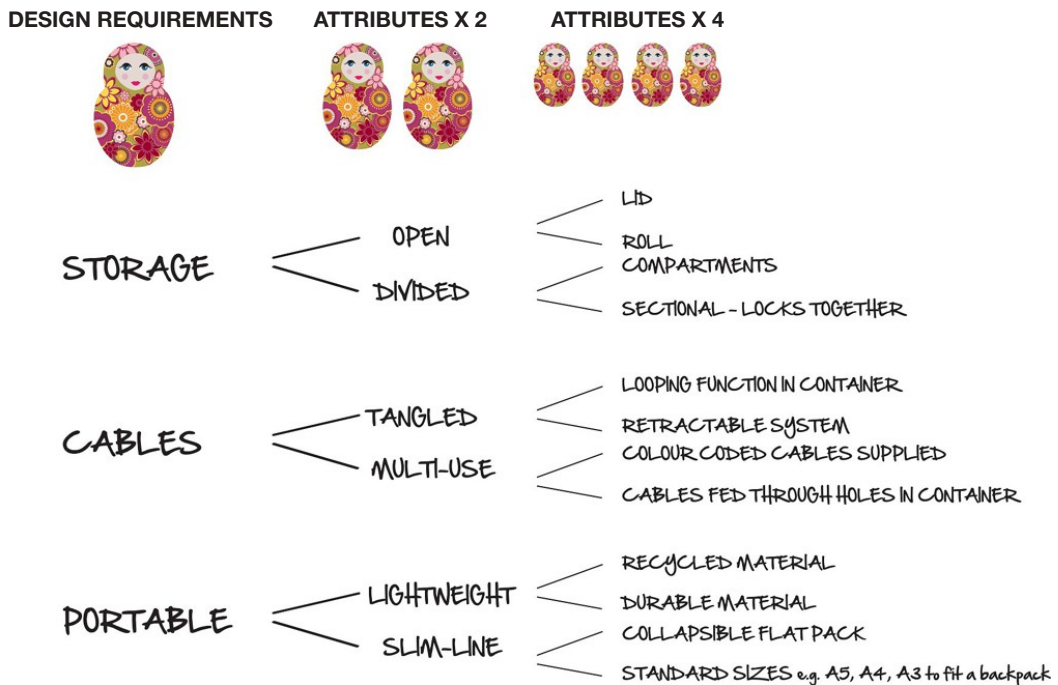

## The idea box

Based on the ‘morphological box’ created by Dr Fritz Zwicky, this thinking tool enables new ideas to form using the existing characteristics of the design problem. Beginning with the characteristics of the design task at the top, list possible variations in each column. Then make connections between each column to stimulate new design combinations.

The simpler the box, the fewer variations; the more complex the box, more possibilities arise. See the example, then create your own.

Example below: Idea box for the design of a stylish, portable storage container that accommodates cables, chargers and other connections for mobile devices and laptops.

Stylish and portable storage container				
	Form	Materials	Appearance	Context
1	Spherical	Plastic	Clear or see-through	Carried in a bag or backpack
2	Rounded	Metal	Natural/eco	Fits in a pocket
3	Rectangular	Netting	High-vis	Sits on a desk
4	Soft/organic	Textile	Able to be individualised	Attached to a wall
5	Cube	Wood	Quirky	Used on a worksite

### Idea Box - Identity Design

Type	Other Aspects	Shape	Colours
1. Handwritten	Pattern	Circle	Indigos
2. Sans Serif	Human Figure	Geometric	Pinks
3. Serif	Floral	Spiral	Oranges
4. Script	Plants	Organic	Black
5. Decorative	Pop Culture references	Star	White

THE SEPARATION BETWEEN THE HANDWRITTEN AND THE SUBJECTIVE STYLING DOESN'T FIT MY AUDIENCE!

NO. NO. NO.

THIS IS AN ATTEMPT AT SHEDDING AS A WOOD-LIKE WOOD WOULD LOOK AS A BACKGROUND DESIGN. LITTLE BITS OF ORGANIC SHAPES WHICH WOULD FIT WITH THE AUDIENCE.

VERY RANDOM

THE MUSHROOM WOULD NOT WORK IN A LOGO, THE TYPE ON THE OTHER HAND PLAYS WITH ORIENTATION WHICH IS AN INTEREST.

PUTTING THE TYPE INTO ANOTHER SHAPE TAKES AWAY FROM THE NAME, SO THIS IDEA WOULD NOT WORK IN ANY CIRCUMSTANCES.

THE REFINING OF COLOURS SHOULD BE SOMETHING TO PLAY WITH. IT ADDS INTEREST AND THE IDEAS ARE THAT I AM GOING FOR.

THE HUMAN FIGURE BEHIND IS TOO MUCH FOR THE IDENTITY DESIGN, BUT THE TYPE POTENTIAL.

PLAYING WITH SOME IDEAS THAT HAVE ALREADY BEEN THROWN OUT, BUT DOES NOT WORK AESTHETICALLY.

Jessie Jones

▲ This student used an idea box to assist in developing ideas for an identity design.

## POOCH

The POOCH model assists in critical thinking and decision making. POOCH can be used to help choose between options during the design process.

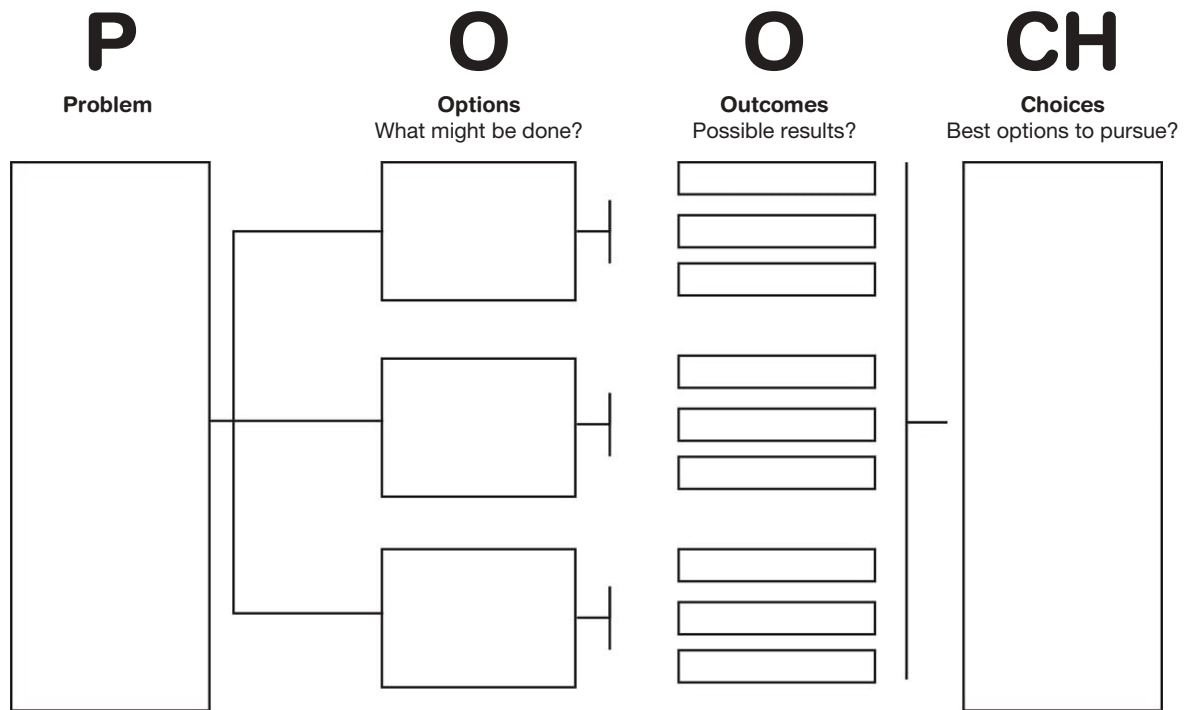

## SCAMPER

SCAMPER is a checklist, created by Bob Eberle, that helps you to think of changes you can make to an existing idea in order to create a new one. Use these changes either as direct suggestions or as starting points for new ideas or concepts. SCAMPER is particularly useful in product design but it can be applied to any concept that requires creative development.

You may not use all aspects of SCAMPER in every design – make use of the parts that are relevant and inspiring. In using the tool consider your application of design factors such as elements and principles of design, materials, sustainable practices. Give thought to the use

and incorporation of different graphical representations.

SCAMPER stands for:

- S** – Substitute
- C** – Combine
- A** – Adapt
- M** – Modify
- P** – Put to another use
- E** – Eliminate
- R** – Reverse

## ▼ Key questions using SCAMPER

	Actions
<b>Substitute</b>	Consider replacing all or part of your design with alternative options.
<b>Combine</b>	Create something new by combining parts of the design or introducing new combinations.
<b>Adapt</b>	Think about how the use of function of the design could be changed to suit a different purpose or set of circumstances.
<b>Modify</b>	Consider radical change to all or part of the design. Think about the distortion of some aspects.
<b>Put to another use</b>	Think about how the design could be used in another way. Could an aspect be sourced from another design?
<b>Eliminate</b>	Reflect on what could be removed from the design. 'Less is more', or is it?
<b>Reverse</b>	Consider completely 'flipping' one or more aspects of the design. Physically or conceptually.

## ▼ Sample SCAMPER template

SCAMPER elements	Key questions to ask	What are the possible results in your design?
<b>Substitute</b>	<ul style="list-style-type: none"> <li>+ What if I swap this for that and see what happens?</li> <li>+ Who else could find this appealing or useful?</li> <li>+ What other materials, design factors could I use instead?</li> <li>+ What happens if I substitute the shape, texture, form or colour?</li> </ul>	
<b>Combine</b>	<ul style="list-style-type: none"> <li>+ What elements or principles of design can be combined?</li> <li>+ What graphical representations could be combined?</li> </ul>	
<b>Adapt or Add</b>	<ul style="list-style-type: none"> <li>+ What part of the concept can I change?</li> <li>+ What if I were to use parts of other design elements or principles?</li> <li>+ What if I re-use aspects of my design in other ways or other places?</li> </ul>	
<b>Modify or Magnify or Minimise</b>	<ul style="list-style-type: none"> <li>+ What happens if part of the concept is expanded, exaggerated, minimised or changed?</li> <li>+ What is the effect of altering proportions and relationships in the design?</li> </ul>	
<b>Put to another use</b>	<ul style="list-style-type: none"> <li>+ What other function or use can my concept be applied to?</li> <li>+ Can another design feature from another product be used in my idea?</li> </ul>	
<b>Eliminate or Erase</b>	<ul style="list-style-type: none"> <li>+ What can be removed from my concept?</li> <li>+ What can be understated or streamlined?</li> <li>+ What happens to the design if parts are taken away?</li> </ul>	
<b>Reverse or Rearrange</b>	<ul style="list-style-type: none"> <li>+ What is the opposite of what I am currently doing?</li> <li>+ What if I did it the other way round?</li> <li>+ What if I reverse the elements or the way it is used?</li> <li>+ What happens if I mix up the design?</li> </ul>	



▲ This student was inspired by the spout of the 9091 Kettle, designed for Alessi by Richard Sapper. Using SCAMPER, she applied Adapt and Put to another use to develop creative ideas for the decorative closure on a handbag.

**LINK: OPEN IDEO**

Initiated by the renowned design studio, Open IDEO is an open platform for creative individuals from around the world to collaborate on innovative design ideas through brainstorming and discussion. You can link directly to Open IDEO via <http://vcd.nelsonnet.com.au>.

**REFLECTIVE THINKING**

Reflective thinking often takes on the role of **evaluation**. Ideas are objectively analysed to

understand how well (or not) they address the original design problem. However, this does not mean that evaluation only occurs at the end of the design process. Throughout the creative evolution of ideas, it is essential to maintain reflective thinking practices to judge the direction of a design solution. Reflective thinking should assist you in learning from your decisions and help you to identify next steps.

**Plus, Minus, Interesting (PMI)**

Arrange the positive and negative aspects of a design idea into categories. Use the 'interesting' section to identify what might be changed when developing this idea further. Example of a PMI:

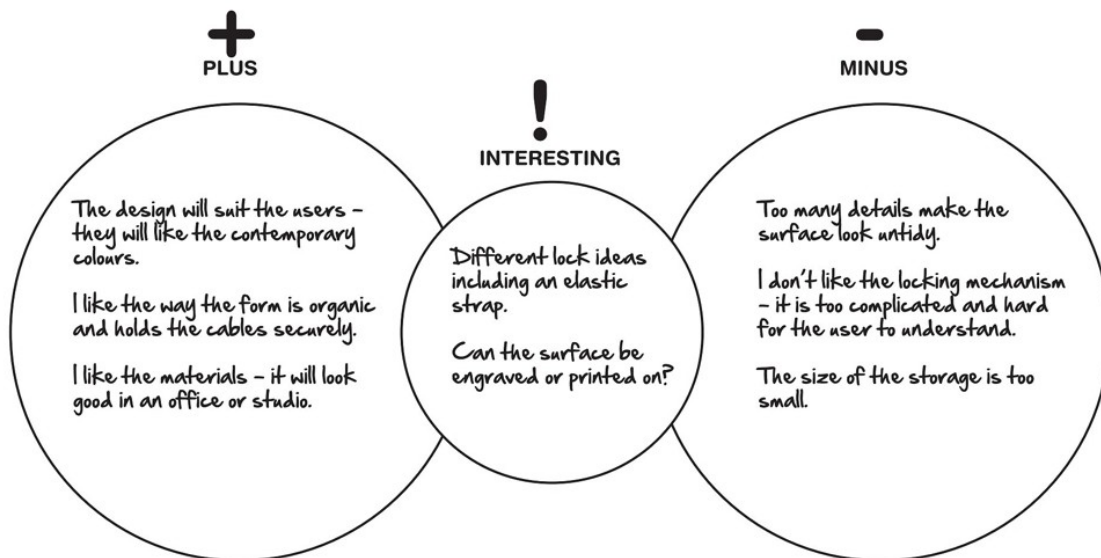



PLUS +

MINUS -

INTERESTING !

Stobhan Brown

- THE USE OF A SIMPLISTIC, CLEAN SANS SERIF FONT SUGGESTS A MODERN VIBE OF THE BUSINESS.
- THE FORM OF THE BRANCH CREATES AN UNDERLINE THAT DRAWS IN THE EYE, WHILE STILL INCORPORATING THE ORGANIC SHAPES OF THE LEAVES.
- THE LOGO APPEALS TO THE TARGET AUDIENCE'S INTEREST IN ART AND DESIGN.
- THE PINK/RED TONES APPEAL TO THE MORE FEMALE ORIENTATED CLIENTEL.
- THE ORGANIC FORMS CREATED BY THE WATER COLOUR SUGGESTS A BLOOMING FORM.
- THE CIRCULAR SHAPE THE MULTIPLE TYPES OF BRANCHE AND FLOWERS ARE PROTRUDING FROM GIVES THE IMPRESSION OF THINGS BLOOMING, WHICH IS ENHANCED CROPPING.
- THE COLOUR PALETTE WILL INTEREST A LARGER CLIENTAL.
- THE EXCLUSIVE WHITE COLOUR OF CIRCLE IS CLEAN AN MODERN.
- THE SANS SERIF TYPEFACE IS CLEAR AND EASY TO READ.
- NEGATIVE SPACE HAS BEEN USED TO CREATE A BLOSSOM, WHICH HAS BEEN USED AS A POINT OF VISUAL INTEREST.
- THE COLOUR WED TO CREATE THE BLOSSOM FRAMES THE TEXT WHICH DRAWS IN THE AUDIENCES EYE.

- DOESN'T DIRECTLY LINK TO THE CONNOTATIONS ASSOCIATED WITH THE IMAGARY RELATED TO BLOSSOMS.
- THE SIMPLISTIC NATURE OF THE LOGO MEANS THERE IS LIMITED POINTS FOR VISUAL INTEREST.
- THERE IS A LOT OF NEGATIVE SPACE SURROUNDING THE TEXT
- THERE IS A LOT OF NEGATIVE SPACE SURROUNDING THE TEXT
- THE BLOSSOM SHAPE IS LESS OBVIOUS
- THERE IS A LOT OF NEGATIVE SPACE.
- THE OVERALL SHAPE IS LESS COMPACT AND MAY BE HARDER TO BE APPLIED TO MULTIPLE FORMS.

- THE LIMITED USE OF COLOUR DRAWS EYE TO THE BLOOMING LEAVES WHICH RELATES TO THE LITERAL MEANING OF THE BRAND.
- THE HIERARCHY DRAWS THE EYE TO SEE THE VISUAL REPRESENTATION OF BLOSSOM BEFORE READING THE TEXT.
- THE CIRCULAR SHAPES IS EASILY APPLICABLE TO MULTIPLE FORMS OF PACKAGING.
- THE CIRCULAR SHAPE IS EASILY APPLICABLE TO MULTIPLE FORMS OF PACKAGING AND COMPANY MATERIALS.
- THE MULTIPLE FORMS OF BLOSSOMING SHAPES CREATES VISUAL INTEREST.
- THE USE OF WATER COLOUR GIVES AN ARTISTIC FEEL TO THE LOGO, THAT HELPS TO CONVEY A MODERN AND UNIQUE AESTHETIC.
- THE WATER COLOUR HELPS TO CREATE ORGANIC SHAPES THAT HELPS TO CONVEY A MODERN AND UNIQUE AESTHETIC.

▲ This student applied the PMI technique to evaluate the effectiveness of three possible identity designs.

## SWOT analysis

A SWOT analysis is a framework for analysing the strengths and weaknesses of a design, and the opportunities and concerns (threats) that it raises. It helps to focus on strengths, address concerns, and take advantage of opportunities that are identified.

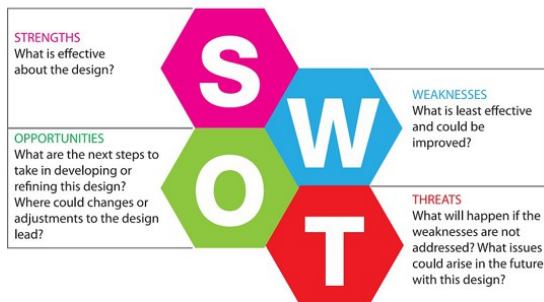

## CHAPTER RECAP

- 1 Create a simple illustration or cartoon that shows the differences between critical, creative and reflective thinking.
- 2 Develop a brainstorming toolkit. Create a set of 20 or more cards with random words placed on each card. Use them to stimulate ideas when you get stuck or need a new design direction. Add to the collection as you think of more helpful or inspiring words.
- 3 Use the SCAMPER template and write alternative ideas for a simple object that might be found in a Visual Communication Design class, such as a pencil sharpener, pencil case or equipment box.



# VISUAL LANGUAGE AND ANALYSIS

CHAPTER

10

## In this chapter:

- + What is visual language? ..... 218
- + Understanding the user/audience ..... 218
  - » Audience characteristics ..... 218
  - » Fashion and trends ..... 222
  - » Human factors in design ..... 223
  - » User analysis ..... 225
- + Visual devices ..... 226
  - » Shock ..... 226
  - » Humour ..... 227
  - » Metaphor ..... 229
  - » Emotion ..... 229
  - » Brand power ..... 229
- + Analysing visual communications ..... 230
  - » Advice for effective analysis ..... 230
  - » Analysing the purpose of visual communications ..... 231
  - » Analysing the context of visual communications ..... 232
  - » Analysing the audience of visual communications ..... 233
  - » Analysing design elements and design principles ..... 235
  - » Analysing media, methods and materials ..... 237

## Learn the language

analysis	end user	interaction	terminology
branding	ergonomics	shock imagery	user-centred design
empathy	humour	target audience	visual metaphor

You will find helpful tasks related to this area of visual communications in Chapters 3, 4, 5 and 10 of *Nelson Visual Communication Design VCE Units 1–4 Workbook, Edition Three*.

## WHAT IS VISUAL LANGUAGE?

Visual Communication Design uses a language of images and terms that enable the communication of ideas through experiences, images and objects. Visual language covers creative processes, systems and rules, concepts and ideas as well as rapid development in technology. Expressions used in Visual Communication Design have origins in the imagery and terms used by designers, academics, demographers and in the wider culture. It is an expanding language, where expressions can be specific to an area of design; for example, ‘kerning’ is a word native to typography and it is also a noticeable visual error when it is not used appropriately in a visual communication. As a student of design, learning the language is an integral part of building skills and experience. Skill in the articulation of visual language in both written and visual forms, culminates in high-quality outcomes and effective design products. With easy access to the tools of design, many people may call themselves ‘a designer’ and charge \$5 for a quick logo design. However, it is the understanding and application of visual language that produces truly memorable, effective and enduring design.

Visual language is:

- + **terminology** and practices, specific to design fields
- + the application of thoughtful aesthetic judgement to create effective design
- + the effective use of methods, media, materials, design elements and design principles to communicate an idea or message
- + the appropriate application of conventions and rules in technical drawing.

Using visual language involves:

- + knowledge of visual meanings and symbols
- + knowledge of the **target audience** and end user
- + understanding how to attract and maintain interest
- + the ability to make objective creative decisions.

Visual language is often specific to design fields. The representation of building materials in an architectural drawing, the engineering symbols used in the orthogonal drawing of a product design and the bleed or crop marks indicated in the proof of a print publication, are all pertinent to practitioners and specialists in each field. However, there are universal understandings that are vital to all areas of design. As discussed in Chapter 8, the design process may vary slightly and be influenced

by the communication need, but many aspects remain consistent across all design fields. A shared language includes the importance of design research and, in particular, a thorough investigation and understanding of the target audience/end user.

## UNDERSTANDING THE USER/AUDIENCE

All design has an end user or audience. Although the audience will always vary, it is important for a designer to fully understand and respond to user needs. Audience and user research is an integral part of a design process and often defines the direction of design concepts. The characteristics of an audience are often divided into specific types of data such as age, gender, socioeconomic status and interests. Other factors such as cultural background, educational level and religious affiliation can also affect the content, appearance and functionality of a design.

### AUDIENCE CHARACTERISTICS

<b>Age</b>	Age groups may be identified in very specific terms (e.g., 18–25 years) or more broadly (young adult, baby boomer, etc.).
<b>Gender</b>	The target audience may be male, female or gender non-specific. Gender can be a very strong influence on consumer preferences.
<b>Socioeconomic status</b>	Refers to the financial and social position of an audience, usually identified by employment status, salary level or educational background.
<b>Interests</b>	Covers a vast range of categories and subcategories, including music, sport and fashion. A target audience might be an association of professionals or an organisation for people who share a common interest.
<b>Cultural and religious background</b>	Content may be influenced by the belief system of the audience. The appropriateness of imagery and content will be defined by cultural and religious traditions.

<b>Location</b>	Where an audience lives can have an impact on their opportunities to view visual communications and on their employment or socioeconomic status. Location can determine visual and oral language and be linked to cultural or religious factors.
-----------------	--

### Audience categorisation

It has become popular, over the past 20 years, for marketers and social commentators to categorise consumers into birth-related groupings such as the following:

- + Mature consumers: born between 1900 and 1945
- + Baby Boomers: born between 1946 and 1964, in the era after the Second World War
- + Generation X: born between 1965 and 1980

- + Generation Y: born between 1981 and 2001
- + Millennials: born 2000 onwards.

When we write about the audience in analysis or as an annotation, it is helpful to avoid stereotypes. It is easy but unhelpful to categorise people into conventional groups, for example ‘hipsters’. In an environment that is saturated with visual content, a designer must have specific knowledge of the audience to break through and make a visual and, if required, commercial connection. It is advisable to avoid formulaic groupings and develop a deeper profile of the end user. Think about your friends and family, your school colleagues or workmates; chances are they are a diverse group. To add to your design vocabulary, create descriptive lists that will assist in describing *who* you are designing for.

Demographic descriptors	Personal characteristics	Socioeconomic descriptors	Other descriptors
Singles	Youthful	Professionals	Socially aware
Families (young family, new family, established family)	Outgoing	Young professionals	Environmentally aware
Seniors (60+)	Carefree	Older professionals	Informed
Elderly (75+)	Happy	Tradespeople/tradesmen	Hard working
Retirees	Social	Qualified/highly qualified	Self-sufficient
Pensioners	Adventurous	Manager	Sedentary
Middle aged (40+)	Risk-taking	Employee/employer	Engaged
Adults	Conservative	Unemployed, job seeker	Politically aware
Parents (mothers, fathers, grandparents)	Frail, unwell, sickly	Highly educated	Interested in social justice
Couples	Experienced	Poorly educated	Family-oriented
Non-traditional families/couples	Worldly	Corporate	Community-minded
Young adults	Organised	Retired (supported by pension, family, superannuation)	Responsible
Students	Sensible	Privileged	Outspoken
Teenagers/adolescents	Quirky	Deprived	Critical of...
Youth	Creative	Budget-conscious	Supportive of...
School-leavers	Eccentric	Average incomes	Passionate
Pre-teens (twens)	Independent/dependent	Student	Impassioned
Children	Intellectual	Graduate	Multicultural
School-aged children	Busy	Tertiary educated	Migrant background
Toddlers	Mischievous	Undergraduate	Non-English speaking background
Infants and babies	Loving, caring	Employed full-time/part-time/casual	Culturally diverse
	Empathetic, compassionate	Well paid/poorly paid	
	Helpful	High income/disposable income	
	Intelligent	Moderate income/disposable income	
	Fit and healthy	Low income/disposable income	
	Colourful		
	Relaxed		
	Focused		
	Positive		

Demographic descriptors	Personal characteristics	Socioeconomic descriptors	Other descriptors
	Energetic, vibrant Concerned, worried Chic/fashionable Sophisticated / unsophisticated Multicultural Curious, intrigued Optimistic/pessimistic Enthusiastic, keen, motivated Sporty, athletic, active	Independent/dependent Stay-at-home (parent) Working from home (small business) Business owner Worker Secure/insecure Ambitious Single income/dual income/ limited income Wealthy Established Reliant	

Research is important because it can not only provide important information about WHO you are designing for but also help to identify fashion and trends in design. Contemporary designers understand that it is important to stay up to date with changes in tastes, preferences, technologies and materials. Very often, these changes can be identified through the behaviour and feedback of the target market.

There are many different research techniques that can be utilised when investigating the target audience of a design. Sometimes the client provides designers with detailed analysis of the end user while other briefs see the designer generating their own research. Some use a range of techniques while some may use only one or two to familiarise themselves with the characteristics of the end user. In your own work it is important to first establish what it is that you need to know about your target audience and then select research methods that are best suited to gathering the relevant information that will help to propel your design to a successful resolution.

## Observation

One of the simplest methods of research available to a designer is direct observation of the target audience. Watching the end user enables the designer to see behaviour and **interactions** in environments that may be familiar to the audience. Casual observation of how an environment or space is used, how a product is handled or responded to and the way in which a user reacts to a graphic design provide data that may be helpful in identifying the needs of the target audience. Observing how people react to visual stimuli can also

occur in a more controlled environment; focus groups, for example, provide a sample of users brought together to discuss and respond to design concepts. Observations of the dynamics and reactions of the focus group may be made discreetly via video or a two-way mirror.

Built environment designers make regular use of observation. Known as site analysis, architects, interior architects and landscape designers will visit a proposed site, not only to observe important physical details about a structure but also to gather information about the space and how it might be used by the end user. Factors such as accessibility, pedestrian and transport traffic flow, and movement and circulation within the site are all important considerations in environmental design.

## Market research techniques

Market research is widely used in business to gain information about consumer preferences. In the form of interviews, email surveys, questionnaires or telephone canvassing, companies collect data about the likes and dislikes of people from a wide range of backgrounds. As audiences change in tastes and become more aware and sophisticated as consumers, data collection can be helpful in gaining insights into cultural and societal changes.

## Audience collage

An audience collage is a visual representation of the characteristics of the end user/market. Using images, colour swatches, patterns, typography and symbols it is possible to create a visual overview of the people

that make up the target audience for the final design. An audience collage is a visual tool and can be beneficial when presenting research findings to a client or as a concept to share between co-designers working on the same design project. At a glance, the audience collage can represent visually what might take pages to describe in words.



Prue Edmunds

▲ This audience collage provides a visual ‘snapshot’ of the lifestyle, interests, socioeconomic status and location of the target audience. A collage can assist in inspiring ideas based on an audience-appropriate aesthetic.

## Personas

A persona or persona profile is a representation, both written and visual, of a ‘typical’ member of the target audience. Ordinarily they are fictional and personify the characteristics of the most recognisable audience members. A persona can capture the ‘essence’ of the end user and assist in guiding the design process by targeting the appearance, functionality and design ideas towards the preferences of this fictional character. When working in a team, designers may use multiple personas to ensure that all team members are designing for the same set of audience interests and needs.

A persona will often include data about the character, a visual reference and detailed summative information about their key characteristics such as age, gender, employment, location and so on.

It can be helpful to build one or more personas in your design work so that you are able to identify who your target audience is throughout the design process. Keeping the end user in mind throughout a long design process can be challenging, so creating a character to reference at different stages can be very helpful in staying focused.

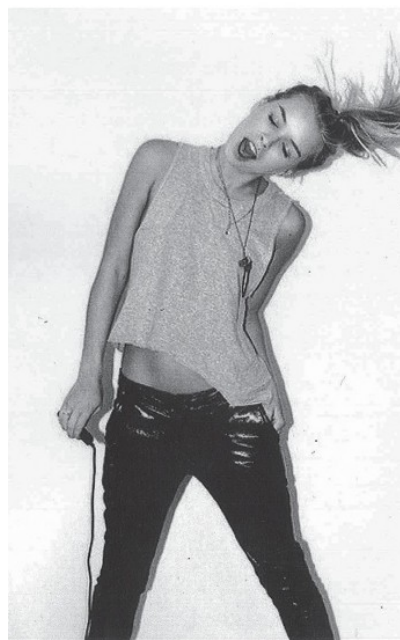

### *PERSONA (typical audience profile)*

*NAME Ingrid Pertunia*

*AGE 22*

*STATUS Single*

*INCOME Disposable*

*OCCUPATION Student*

#### *INTERESTS*

*Socialising with friends, at cafes, bars & clubs.*

*During the day Ingrid is at Uni or working.*

*She enjoys listening to alternative, electro, folk and rock music, depending on her mood.*

*She appreciates good design in architecture and advertising.*

*Shopping is a common pastime in her breaks at Uni and one day she would like to travel around Europe and South America.*

Sarah Mason

▲ This student used a persona profile to assist in identifying the target audience of the interior design of a fashionable new bar to be located at music festivals.

## Social media



Shutterstock.com/tamuha2001

▲ These social media icons are instantly recognisable.

Analysis of social media sites offers a wealth of information, both visual and written for the design researcher. Many demographic groups, but especially younger markets who traditionally have a high disposable income, are heavy users of social media and appear willing to share a wealth of personal data publically. Using sites and apps such as Instagram, Pinterest, Facebook and Google+ it is possible to develop detailed profiles of users within a particular age range or interest group. Be aware of privacy considerations when accessing information about real individuals; seek permission if you plan to use photographs that belong to others (see Chapter 13 for more information on legal responsibilities including privacy and copyright).

## Usability testing

Later in the design process, when you have progressed towards a design solution, it can be helpful to research the responses of your target users. Designers apply usability testing to assess the progress of a design concept. Most commonly used in industrial/product design, usability tests for suitability, functionality and aesthetic appeal. Participants may be given the opportunity to handle prototypes and scale models to develop an understanding of form and function. Data collected from trials and tests with members of the

target audience can help resolve design issues, address **ergonomics** and apply changes to meet an appropriate design solution. Communication designers may also apply usability testing to focus groups, asking participants to comment on a range of design ideas for advertising, packaging, websites or other forms of visual communication.

## FASHION AND TRENDS

Recognising and responding to fashion and trends in design is big business. Very often, users demand the newest and most up-to-date designs and the marketplace moves quickly to meet that demand. Many areas of design such as fashion design, textile design and interior design undergo seasonal shifts in colour, styling and theme. These cycles can occur very quickly and what was fashionable last month may no longer be seen as desirable next month. Blogging and the visual feast that is social media can influence what is and what is not fashionable over relatively short periods of time. Designers stay up to date with trends and developments by reading widely, attending expos and conferences and observing cultural shifts. In many cases, innovation and trends are set in motion by talented and innovative designers themselves.

### FASHIONABLE COLOUR!

FYI

Colour forecasting is big business. Professionals working in fashion, interior design, product design and manufacturing often begin the design of a concept many months – and even years – in advance. Predicting colour trends is therefore very important to ensure that a design is relevant and marketable in the future. Companies such as Pantone, Edelkoort and Fashion Forecast Services provide clients with reports that analyse trends in fashion, accessories, textiles, paint colours and furniture.



PANTONE® and other Pantone trademarks are the property of Pantone LLC. PANTONE Colors may not match PANTONE-identified standards. Consult current PANTONE Fashion, Home + Interiors Publications for the accurate color.

- ▲ Pantone release a ‘Colour of the Year’ that reflects current trends in design, fashion and interior architecture. This illustration shows all Pantone colours of the year from Cerulean in 2000 (bottom right) to Rose Quartz and Serenity in 2016 (top far left).

Although trends appear more slowly in built environment design, the design of spaces and structures is also affected by changing preferences in the application of materials, colours and textures. Product design may also be influenced by colour trends, changes in the desired appearance, form and shape of consumer products and a demand for innovative materials and technologies.

Aesthetic preference plays a major role in user decisions when faced with a choice of designs. Aesthetics relate to the physical appearance of a design and a well-designed product that makes effective use of principles of design such as harmony and balance is naturally more appealing. For more information on the power of colour in design, see Chapter 5.

## HUMAN FACTORS IN DESIGN

Not only do the preferences and tastes of the target audience need to be taken into account, the physical characteristics of the human body have an impact on industrial design and built environment design in particular. The way humans ‘fit’ with a design, and how they interact both physically and with their senses are important considerations in design.

### Ergonomics

Ergonomics is the study of human factors in design and how human beings interact with products and

environments. This scientific discipline looks at the functions, limitations and needs of the human body in relation to product design. Ergonomists often work with designers to design products that take into account the physical, organisational and psychological effects on the user. You may be familiar with ‘ergonomic furniture’ which is often a selling point of chairs and desks for a home study or office environment. Standard ergonomic height requirements exist so that the user is most comfortable when seated at a desk for a prolonged period.

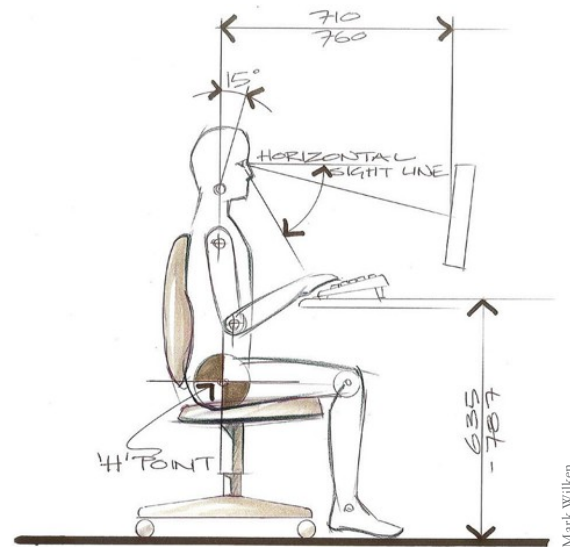

- ▲ This diagram indicates the ideal height of the desk and chair as well as the preferred position of the user. Anthropometric data about human body size is taken into account in the design of ergonomic products (anthropometry is the study of human body size, posture, movement, surface area, volume, and mass). Due to the vast variety of human shapes and sizes, many designs need to take into account the physical characteristics of the average user and apply proportions that suit a wide range of people.

Ergonomics is concerned with the interactions between the user and a product and relates not only to physical and biomechanical interactions with design but also cognitive processes such as memory and decision making. Good design takes such factors into account and ensures that a product is not so difficult to use that a user can’t operate it or remember simple functions.

Ergonomic principles are embedded in the publications of organisations such as Australian Standards, whose guidelines cover the design and



manufacture of products and built environments throughout Australia. All products sold and used in Australia must meet the relevant standards, which range from the paper pulp used in packaging to water quality, domestic appliances and road vehicles, mining technologies, smartphones and food. The purpose of standards is to ensure safe design and manufacturing practices lead to the safety of the end user.

**LINK: ERGONOMICS**

For more detailed information about ergonomics, visit the International Ergonomics Association website. You can link directly to the Association via <http://vcd.nelsonnet.com.au>.

### User interface design

In digital design, users interact with a screen, and the design of intuitive and functional interactions is very important to the success of computer-operated systems, apps and software products. With the growth of smartphones and tablets, user-experience design or **user-centred design** is a field that has developed to meet the needs of increasingly educated technology users. User designers focus on developing digital products that are easy to use and make the most of users' existing familiarity with technological functions.

An important aspect of user-centered design in digital media is to enable users to access and use new applications without significant levels of learning. Users prefer to pick up a device with the confidence that fundamental functions will operate in the same or similar way to previous devices. This is a challenge for digital designers and reinforces the importance of having a good understanding of audience needs before commencing the design process. Users will learn new functions but it is the designer's challenge to present innovations in an accessible manner, and it is here that the application of design elements and principles is of paramount importance.

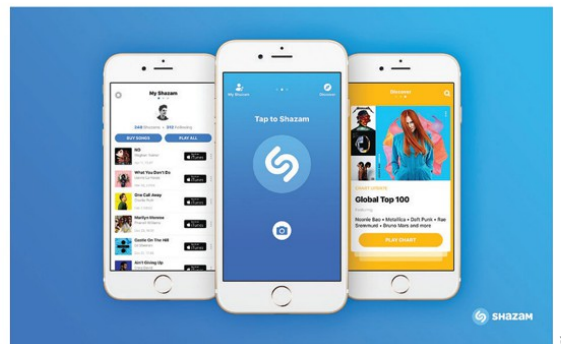

▲ The popular Shazam app identifies music and images via smartphone or tablet and uses design elements such as shape, type and colour to instruct the user. The app, which has been downloaded more than 1 billion times, has clear design, effective design elements and simple instructions that make it an easy app for users to learn.

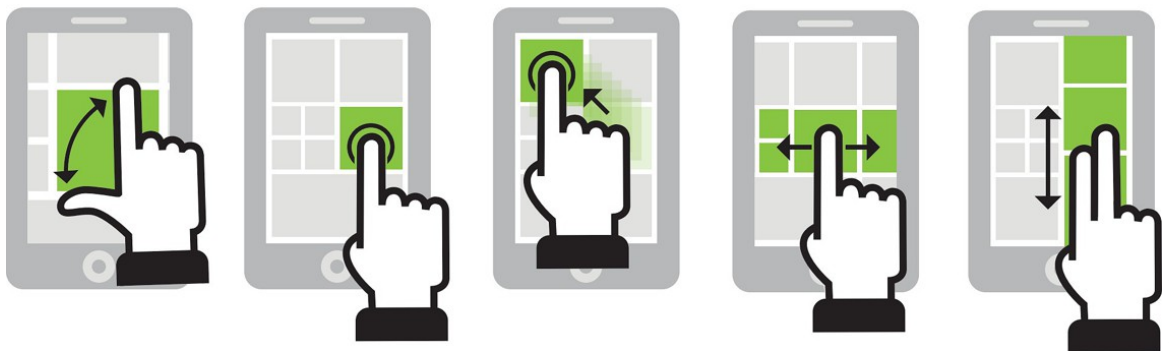

▲ This diagram illustrates some of the finger gestures required to navigate a tablet by touch. Interestingly, the first tablets established these gestures as standard and subsequent tablet designs have applied them in the same way. Ensuring consistency in interactivity means that users do not have to relearn complex processes when using a new product or software system.



- ▲ OXO Good Grips are a suite of domestic products originally designed for people with limited functionality in their hands such as those suffering with arthritis. Interestingly, the success of the designs has been due to users of all abilities recognising the excellent ergonomic properties and high level of comfort.

## Accessibility in design

From the humble potato peeler to low-floor buses, the design of products, the environment and graphics is constantly evolving to meet the needs of people with a range of abilities and disabilities. In particular, the designs of many public environments and some products are required to accommodate the needs of users with disabilities. Designers research the capabilities and limitations of users and strive to design products that are inclusive and accessible to them.

Designers use research and observation to understand the requirements of users with special needs and respond with solutions that use form, space, texture and colour among many other elements and principles of design. Consider the use of braille on lift controls, reflective textures on road signs and lighting controls that can be distinguished by texture; all were designed in response to users with limited or poor vision. Assistance for users with sensory limitations such as hearing loss, vision impairment and physical disabilities are often incorporated into design fields such as transport, the built environment, wayfinding (signage), digital design and many others. Although Australian Standards usually require accessibility considerations to be factored into designs, it is important that designers consider all potential users of their final design product and explore innovative means of meeting their needs.

### LINK: HUMAN-CENTRED DESIGNERS



Smart Design and IDEO are two large design and innovation firms that focus on the user as the priority in their design processes. The websites of both organisations document their successes in focusing on the user as part of their 'human-centered' approach to designing products, brands and experiences. You can link directly to Smart design and IDEO via <http://vcd.nelsonnet.com.au>.

## USER ANALYSIS

The following questions are designed to help you to document and build your understanding of the end user. You might choose to use this as an online template or to develop your own questions that are directly relevant to your design problem.

A template can be found via <http://www.nelsonnet.com.au>, using your login code from the back of the book. Go to Resources, this chapter and page number, and click on the template.



Scaffold

- 1 Age range of user: \_\_\_\_\_
- 2 Socioeconomic status:  High  Medium  Low
- 3 Disposable income (if relevant):  
 High  Medium  Low
- 4 Interests and tastes:

Brands. Which?	Music. What?	Magazines and TV. What?	Social life. What and where?	Shopping. What and where?	Hobbies and Sports. What?

- 5 Where does your user spend most of their time? (circle all that apply):
  - + School/university
  - + Work
  - + Home
  - + Outdoors
  - + Indoors
  - + Alone
  - + In company
  - + In an office
  - + Working as part of a team
- 6 Circle the key words that describe the user:
  - + Contemporary
  - + Fashion-conscious
  - + Adventurous
  - + Cutting-edge
  - + Alternative
  - + Ethical
  - + Conservative
  - + Environmentally focused
  - + Politically minded
  - + Social
  - + Carefree
  - + Cheap
  - + Expensive
  - + Natural
  - + Extravagant
  - + Stylish
  - + Safe or cautious
  - + Family-focused
  - + Youthful
  - + Technology-savvy
  - + Elderly
- 7 List any other words that describe the market:  
.....  
.....
- 8 What is important to the user?
  - + Social and political issues
  - + The environment
  - + Technology
  - + Social networking
  - + Saving money
  - + Spending money
  - + Luxury
  - + Security
  - + High quality
  - + Low price
  - + Contemporary design
  - + Traditional design
  - + Innovation
  - + Tradition
  - + Natural things
  - + Manufactured things
  - + Accessibility

- + Ease of use
- + Learning/education
- + Problem solving
- + Following trends

9 Describe the aesthetic preferences of the audience:

Colours	
Shapes and forms	
Patterns and decoration	
Materials and textures	
Specific abilities and/or disabilities	
Any other preferences	

## VISUAL DEVICES

Visual communications, particularly those used in the advertising of products and services, exist within a highly competitive market. Gaining and maintaining a target audience is the aim of many businesses and organisations. To attract consumers, advertisers and marketers use strategies that range from thought-provoking and clever to controversial and shocking. In raising public awareness of a brand, product or issue, there are many methods and techniques used that we may or may not be aware of.

## SHOCK

For many businesses, advertising is an essential part of commerce. Many people dislike the intrusion and proliferation of advertisements, but both large and small businesses often find that without advertising, public awareness of their business is minimal.

In a competitive marketplace, gaining public attention is often a challenge. We are surrounded by advertising imagery and ‘visual noise’. How does a business or organisation make an impact in such an environment?

Some advertisers see the use of controversial or **shock imagery** as a key to grabbing the attention of consumers. Sexually suggestive or explicit material is often used to sell a range of products, from alcohol to motor vehicles. Advertisements that stir outrage and

controversy generate media publicity, raising the profile of the advertiser and, often, the advertising agency.

Many countries have guidelines that control the content and placement of advertising. Advertisers in Australia are self-regulated, which means that it is

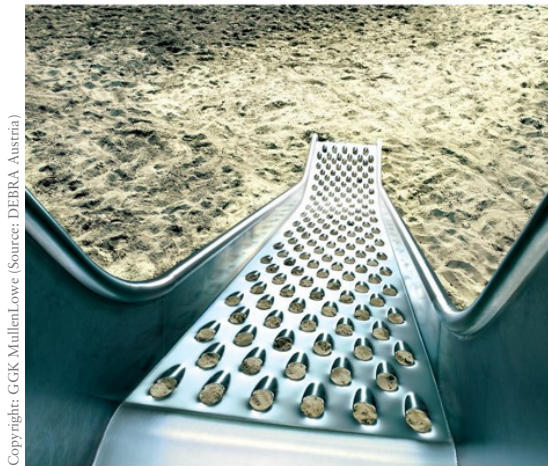

Copyright: GKG MullenLowe (Source: DEBRA Austria)

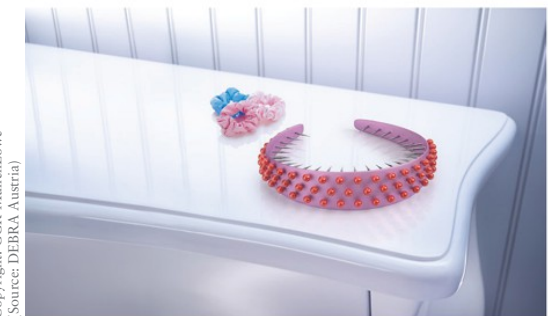

Copyright: GKG MullenLowe (Source: DEBRA Austria)



Copyright: GKG MullenLowe (Source: DEBRA Austria)

▲ The unexpected juxtaposition of imagery in these photos is initially jarring but conveys the nature of Epidermolysis bullosa, a painful skin disorder. The viewer's response is to imagine the feeling of suffering experienced by those who have this genetic condition.

the advertisers themselves who control and police the enforcement of the government guidelines. There are, however, protections in place to protect the rights and privacy of individuals and social groups.

In some instances, the use of confronting or shocking imagery is done for a purpose; non-profit and government organisations may use visual elements that present a strong message. The TAC (Transport Accident Commission) in Victoria is a good example; the confronting imagery used in their promotional campaigns is designed to provoke a positive response in drivers and alert them to the dangers of irresponsible driving practices. Charitable groups such as World Vision may use shocking imagery to elicit a strong response.

## HUMOUR

Like a good joke, visual communications that cleverly incorporate **humour** or wit tend to be remembered and passed on. Humorous or entertaining visual content encourages participation and interaction from an audience. In responding to a visual communication through laughter or even a smile, an audience is interacting with the visual communication.

The creative application of design elements and principles, media and materials can have humorous outcomes. The addition or manipulation of imagery that changes the context of a visual communication is a popular means of grabbing attention.

Contrast is a common means of applying humour in visual communications. Recognisable figures in unrecognisable circumstances create incongruity, and this catches the attention of an audience.

Cleverness and wit can be found in visual communications that are designed to be thought-provoking. In these cases, a belly laugh is not the intention; rather, the intent is the engagement of the audience through the thoughtfulness and cleverness of the visual communication. A design that gets an audience thinking is often a design that has communicated its message. Given that we process visual communication quickly, a design that holds attention and provokes a thoughtful response is valuable.

Witty visual communications can be subtle, encouraging the audience to look deeper, and develop intrigue as well as interest.



▲ Italian design company Alessi is renowned for the humour and whimsy imbued in some of its iconic designs. From left: 'AnnaG corkscrew', 'Diabolix bottle opener' and 'Otto tooth floss dispenser'.

### WHAT CAN WIT DO?

'There are many graphic ways of stopping people in their tracks. The whole nature of graphic design is concerned with spicing; otherwise designers would all use the same typeface and paper. The audience can be arrested by bold imagery, a startling use of colour or elegant photography; but for how long? The best way to win time for the message is to offer something that intrigues.'

FYI

The recipient is then seduced into making a commitment. Someone who is intrigued will stay with the item until curiosity is satisfied. So the first benefit of witty design is that the recipient becomes willing to hear the message; the audience becomes captive, and the communication has the best possible start.'

From Beryl McAllhone and David Stuart, *A Smile in the Mind*, Phaidon Press, 1996.

## METAPHOR

The use of **visual metaphor** in visual communication design is common. Visual metaphor relies on the combination of sometimes unrelated images to impart the message and meaning. It is often seen in the juxtaposition of images in advertising; for example, the depiction of a motor vehicle and a wild cheetah draws the association of speed.

In advertising, visual metaphors are increasingly used with minimal text, demanding insight from the viewer with regard to meaning and association.

Ford Octogrip Advertisement created by Dedicate.eu, reproduced with permission



- ▲ This advertisement relies on the ability of the human brain to draw a rapid link between the suction of the squid and the road handling of car tyres.

## EMOTION

The ability to elicit an emotional response from an audience can provide a visual communication with considerable power. Some researchers believe that an individual's level of emotional response to a visual communication lies in their ability to find **empathy** in a represented situation. In advertising and the promotion of issues, it is common for emotive imagery to be used to elicit an empathetic response from an audience.

Not-for-profit groups, social activist organisations and political groups sometimes use images that unsettle and provoke an emotional response in order to convey a powerful visual message. Images of starving children, mistreated animals or environmental destruction are capable of eliciting sympathy and compassion from the target audience. Designed to create an emotive response, such visual communications are often used in fundraising and in raising awareness of issues.

ISBN 9780170401784

The emotional response triggered by visual communications is not always negative. Over time, many of us develop relationships with products and brands whose familiarity is comforting. Consumers often develop loyalty to a brand or product through historical use of the product and the perception of product quality, or because of the lifestyle associated with the brand. In such cases, the audience often has a positive emotional or personal link to the product.



- ▲ The use of emotive imagery is designed to elicit a personal reaction from the viewer.

## BRAND POWER

Over the past decades, **branding** has become increasingly important to companies, organisations and even individuals. Competition in business and product marketing is intense, and the strength of a brand has commercial value. Recently, the monetary value of branding has been recognised as part of a company's value on the London Stock Exchange.

The power of branding extends beyond the visual identity of a company or product. Brand describes not only the logo and visual communications of the organisation but also the lifestyle that may be associated with the brand. Brand is established through a variety of means, from the design of the corporate headquarters to the content of advertising material.

The content of visual communications produced by a company will often underline the 'lifestyle' of the brand.

Nelson Visual Communication Design VCE Units 1–4

Images of young, attractive and fit people playing touch football on a beach, and drinking a brand of soft drink, not only promote the beverage but also the lifestyle associated with drinking that particular beverage.

Branding can be so powerful that a logo or image can convey the meaning of a brand without requiring the depiction of a product at all.

The growth of brand awareness and brand loyalty has led to a backlash. The domination of markets by brands and the multinational nature of many brands have led to a reaction against consumerism and capitalism by some groups. Groups such as Adbusters, and individuals inspired by the writing of brand activists such as Naomi Klein, often use traditional means of visual communication to create a message that is 'anti-brand'.



David Paul Morris/Bloomberg via Getty Images

- ▲ The wide public recognition of the Nike brand means that the company's logo design does not make mention of the company name or its products.

## ANALYSING VISUAL COMMUNICATIONS

In your study of Visual Communication Design it is important to articulate an understanding of why design decisions are made, using real-world examples. Just as important, however, is how you relate that understanding to your own design work. Knowledge gained through analysis will enhance and inform your design work, and enable you to present not only effective design solutions but also an informed and visible connection between your original analysis and your practice.

In analysing the designs of others, we can build a strong vocabulary of visual language that can be adapted and applied to our own creative practices. Design does not occur in a vacuum, it is informed both by a rich history and dynamic, fast-moving contemporary culture. Effective analysis uses analytical skills to filter and find those designs that most eloquently express best practice.

### ADVICE FOR EFFECTIVE ANALYSIS

#### Be objective

It is acceptable to have an opinion about the effectiveness of visual communications, but good analysis should not be influenced by personal taste, bias or judgement. Your analysis should reflect your ability to make observations and critical evaluations of visual communications, leaving personal judgement aside. Avoid phrases such as 'I like ...' or 'I don't like ...' in your analysis.

#### Use appropriate terminology

Your analysis should reflect your grasp of appropriate visual communication design terminology. You should be able to express your observations and analysis by using terms and language that are particular to the course. You should understand and be able to clearly explain the application and effect of design elements and principles, methods, media and materials. The key words in Chapter 5 offer a range of adjectives that can be used in the description and analysis of design elements and principles.

#### Use evidence

For effective design analysis, there should be a factual basis for your observations. Use evidence and examples to back up your assertions. Simple statements describing the colour or form of a visual communication are more effective when supported by an example. A helpful tip is to imagine that the person who is reading your analysis can't see the example, which means that you need to explain your statements very clearly and use valid examples for support.

## ANALYSING THE PURPOSE OF VISUAL COMMUNICATIONS

See Chapter 4 for more detailed information about the purposes of visual communications. Understanding what a visual communication actually is can provide valuable information about the purpose. If you have access to the original source of a visual communication, its physical details and purpose may be very clear; however, if you view a visual communication on a screen, in a book or from a photocopy, you may need to make a further assessment of its purpose. Many visual communications have multiple purposes, so it is essential to assess carefully. The best approach is to look for clues to the purpose within the visual information itself; the imagery and content provide a lot of information about what the visual communication is trying to achieve.

## About the purpose of visual communications

In analysing the context of visual communications it is important to ask the following key questions.

- + What is the primary purpose? Consider the most obvious and likely reason for the design.
- + Who would most likely respond to the visual communication?
- + What impact does the location have on the appearance of the visual communication? For example, billboard signage = large type and highly visible imagery, magazine advertisement = more text and complex imagery.
- + How are visual communications modified to suit different contexts? For example, a corporate logo is altered in scale to suit different contexts such as letterhead, clothing and transport.

## Sample purpose analysis: I am Big Bird

'The purpose of this visual communication is to promote and/or advertise the release of a film about the man behind Sesame Street's Big Bird character. Text, describing the film title and the visual imagery that depict the man half-dressed as the Big Bird character convey the content of this documentary. We gain an insight into the connection between the man (Carol Spinney) and the character of Big Bird through the use of yellow type that distinguishes their names. The use of colour in both the typography and photograph emphasises the visual characteristics of Big Bird. The poster does not feature a full image of Big Bird, instead it references our association between the recognisable childhood character and the vivid colours of yellow and orange.'

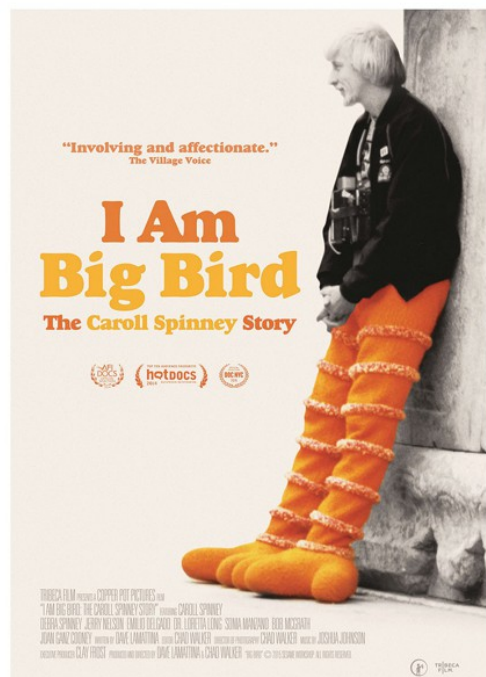



## Helpful phrases when considering purpose

‘The audience is attracted to ...’

‘The application of [design element, media, material, etc.] helps to draw attention to ...’

‘The primary purpose of the [visual communication] is to depict the appearance of ...’

‘The general purpose of ... is to [insert appropriate purpose] and increase public awareness of ... in order to encourage attendance and participation.’

‘More specifically, the [visual communication] informs of the dates, location and website while providing key details to inspire the interest and actions of its audience.’

‘... the use of [design elements and/or design principles] to attract the attention of passers-by.’

‘[The visual communication] incorporates ... to invoke the curiosity and interest of the audience.’

‘Engagement with the [visual communication] is encouraged by ...’

## ANALYSING THE CONTEXT OF VISUAL COMMUNICATIONS

Context in visual communication is about place and time. When a visual communication was created and where it is located has an impact on the content of the communication itself. In order to reach a specific audience, advertising companies undertake a great deal of research to locate the best advertising environment. A misdirected advertising campaign that does not reach the target market can waste millions of dollars.

The location of a visual communication determines who will see it. Visual communications found in trade or profession-specific publications are directed at a narrow audience and differ from visual communications that appear in general magazines directed at a wider social group. The location of a visual communication also has an impact on what is featured, highlighted or included. The visual communication used in billboard advertising of a product or service may be noticeably

## Sample context analysis: Deus Ex Machina



The poster and mail order catalogue for Sydney brand Deus Ex Machina reflect aesthetic trends in visual communication design in the mid 2000s. This time saw an increased use of hand-drawn type

and linear illustration evident in posters, film graphics, book design and clothing. Visual evidence of ‘the designer’s hand’ in raw, informal and calligraphic typography ushered in the artisanal style that still dominates

Reproduced courtesy of the Powerhouse Museum, Sydney, with permission of Carby Tuckwell, Deus Ex Machina Motorcycles Pty Ltd



visual communication design today. Early adoption by cult brands such as Deus Ex Machina leads, a decade on, to ubiquitous use of the style in mainstream branding, retail signage and advertising.



different from advertising of the same product in a magazine or newspaper. When analysing the context of visual communications, it is very helpful to have a good general knowledge about eras and movements in design history. Read widely and follow blogs to build your knowledge and awareness.

See Chapter 12 for more information about the influence of context on visual communications.

## About the context of visual communications

In analysing the context of visual communications it is important to ask the following key questions.

- + Where can the visual communication be found?  
For example, in a publication such as a magazine, newspaper, book or online; in a location such as cafe, cinema or street signage.
- + When was the visual communication designed/produced? How does the era in which it was designed impact its appearance or functionality? What effect does time have on the application of materials, methods and media?
- + Is there a target audience who are specific to the location?
- + What impact does the location have on the appearance of the visual communication? For example, billboard signage = large type and highly visible imagery, magazine advertisement = more text and complex imagery.
- + How are visual communications modified to suit different contexts? For example, a corporate logo is altered in scale to suit different contexts such as letterhead, clothing and transport.

## Helpful terms to describe context

‘The context of this [visual communication] is [location] which implies that the target audience would be located ...’

‘This [visual communication] was created during a time [description of time] when [implications of that time], which is indicated by ...’

‘[The visual communication] most likely would have appeared ...’

‘[The visual communication] may have been distributed among ...’

‘[The visual communication] may have featured on ...’

## ANALYSING THE AUDIENCE OF VISUAL COMMUNICATIONS

Visual communications found in a specific context often indicate the target audience. Magazines such as *Harper’s Bazaar* have a clearly defined target market of young women aged 18 to 25 years, which identifies visual communications contained within those publications as having a similar audience. Similarly, publications such as *Men’s Health* appeal to a male audience aged 20 to 30 years. In such instances the identification of a general audience can be quite straightforward.

Even more specific target audiences can be identified by the context of the visual communication. Statistical diagrams found in a VCE History textbook are obviously targeted at students aged 16 to 18 years who are undertaking VCE studies in that area.

The environment in which products are sold, viewed and used can also provide an insight into the audience. Retail stores in an exclusive area might sell expensive products to a select clientele, while a chain department store may stock a wide range of products to suit a more diverse range of consumers. Where a product is sold and how it is priced, along with its availability, will often determine exactly who can and will purchase the product.

Observation is the key to analysing any visual communication and it is extremely important in determining the possible audience.

When analysing the audience of a visual communication, you should attempt to draw as much information as possible from the visuals provided. You should suggest the age, gender and possible interests of the audience, supporting each assertion with evidence drawn from what you see in the visual communication. Be careful to avoid stereotypes as they are too general and offer little insight into audience preferences or needs. Socioeconomic status should focus on education, employment and income. Again, don’t use generalisations or references to ‘class’ as these can be subjective and unhelpful in illuminating the end user.

See pages 218–222 of this chapter for information about audience characteristics.

## Sample audience analysis: *Monster Team* magazine



'The *Monster Team* magazine would appeal to children of preschool, early primary school age – perhaps 5–10 years. They may be attracted to the brightly coloured animated creatures that are featured on the front cover. The magazine is aimed at a mixed gender audience and features both masculine and feminine monsters. The target audience would be interested in games and toys that are exciting, fun and interactive. At a young age they may have a short attention span, so the variety and colour of the cover would be engaging. The audience would most likely be reliant on parent income for pocket money. They may live in suburban areas and have access to technology including the Internet, computer games and TV.'



### About the audience of visual communications

- + What visual indicators suggest the target audience? For example, consider design elements (such as colour) and the materials applied (such as recycled packaging, etc.).
- + What is the age range of the target audience? For example, 18–25 years, Generation Y, retirees.
- + Are socioeconomic factors an issue in establishing the target audience? For example, consider the cost or implied cost of a product or visual representations of a product, service or event.
- + How are the interests, geographical location and/or cultural sensibilities of the audience identified by the visual communication? For example, consider the context of the visual communication and the use of area-specific, culture-specific or interest-specific imagery.

### Helpful phrases when analysing the audience of a visual communication

- 'The [visual communication] appeals to ...'
- '[Audience description] may find the [visual communication] appealing due to its ...'
- 'The [visual communication] is made for an audience of ...'
- 'The [characteristic of the visual communication] would suit those who ...'
- 'The [visual communication] suggests ..., which would appeal to an audience of ...'
- 'The application of [design element, materials, media etc] suggests [description of effect], which would appeal to the target audience due to their [interest in, preference for, understanding of etc. ...]'
- 'In this [visual communication] the use of [design elements, design principles, media, materials, etc.] produces a [feeling, sense, atmosphere, environment] of ... that the target audience would find appealing because ...'

‘The purpose of the [visual communication] is to [guide, teach, depict, identify, promote, advertise, inform etc.], which suggests that the audience are people who [need, require, are attracted to, are seeking, aspire to, etc.] ...’

‘Targeted by this [visual communication] are people interested in [interests] and keen to [experience, undertake, become involved, enjoy, etc.] ...’

## ANALYSING DESIGN ELEMENTS AND DESIGN PRINCIPLES

Through observation of the design elements and principles, it is possible to identify a great deal of information about the visual communication. Ask key questions that delve more deeply into possible reasons behind the use of the design elements and principles. Why has the designer chosen to use the elements and principles evident in the visual communication? What is the meaning of the use or placement of elements and principles?

For more detailed information about design elements and design principles, refer to Chapter 5.

Design elements	Design principles
Colour	Balance
Form	Contrast
Type	Cropping
Line	Hierarchy
Point	Figure-ground
Shape	Pattern
Texture	Proportion
Tone	Scale

### TIP: MEMORY TRIGGER!

Some students find it helpful to create acronyms to assist in remembering terminology. For example, **FaTCaTSPLaT** may seem like a nonsense word, but each of the consonants is the first letter of one of the eight design elements. Similarly, **SHe PiC PiC BeeF** identifies the eight design principles. Can you think of other acronyms for other important visual communication design terminology?



## About analysis of design elements and design principles

- + What do you see? Often you will be asked to describe a visual communication. A description involves a factual explanation of what you see and where.
- + What is the effect of the design element or design principle within the visual communication? Considering how the use of elements and principles affect a visual communication is where you get into real analysis. How do components of the visual communication work together to convey a message, theme or idea?
- + Why particular elements and principles have been used is difficult to know for certain. However, with your knowledge of visual communications, it is possible to put yourself in the shoes of the designer and consider the reasoning behind decisions and choices.

## Helpful phrases when analysing the elements and principles in a visual communication

- ‘... its treatment contrasts dramatically in style and tone (atmosphere) with/from ...’
- ‘The element of ... dominates the composition ...’
- ‘... thin lines (or other relevant design elements) help to arrange and clarify ...’
- ‘the typographic arrangement ...’ or ‘the typographic treatment ...’
- ‘the design element highlights key details such as ...’
- ‘[the design element] is suggestive of ...’
- ‘... arrangement of [design element/principle] draws the viewer’s attention through the ...’
- ‘... the [use of design element/principle] encourages our (the viewer’s) gaze to be led...’
- ‘the arrangement of [design element/principle] could be likened to ...’
- ‘[design element/principle] communicates a sense of ...’
- ‘the arrangement of [element or principle or image] encourages our (the viewer’s) gaze to be led ...’
- ‘... filling the composition with ...’

## Sample design analyses



### 1 Sample **design elements** analysis



Lomography

▲ Lomo mini Diana camera featuring illustrations by Tara Mcpherson.

Eye-catching pastel colours are used in the body of the Diana camera and similar hues of pink can be found in the illustration that wraps around the front and back. Pale blue also features in the illustration creating a whimsical, feminine appearance. The colours are matte and atmospheric, creating a vintage look and the ethereal design supports this. The fluid, rounded lines of the illustration reflect the smooth forms of the camera itself and references American visual culture of the 1950s and 1960s, which link to the designer's heritage and reinforce the retro/vintage feel of the products. Lines flow from the masked eyes of the young woman in the illustration clearly linking the figure to the highly visual art of photography.

### 2 Sample **design principles** analysis



'A combination of balance and contrast has been used to create a symmetrical and striking billboard image with a clear hierarchy. The black-and-white photograph features strong contrasts of highlights and shadows, which emphasise the dramatic and glamorous full face. Also providing contrast is the warm magenta of the perfume bottle, which is also applied to the title. Both the type and image are separated from the ground, but their alignment draws the viewer's eye, through the bottle form, to the model's direct gaze and ultimately to the product name. The eyes of the model compel the viewer to look and create the focal point of a strong hierarchy. Drawn into the ground, the viewer is subsequently led to the key elements of the advertisement, namely the product and title. A close association between beauty and perfume is common in advertising of this kind, thus the visual connections as evidenced in this example are highly effective.'

## ANALYSING MEDIA, METHODS AND MATERIALS

The material from which a visual communication is constructed can provide strong clues to its purpose, context and audience. For example, visual communications that are designed for the outdoors have quite different material and production needs to those designed for indoor use. Observing the material used in construction will identify the context of the visual communication.

The appropriate use of materials and media has the power to attract an audience. Public interest in eco-friendly design has led to a rise in the application of recycled and environmentally sustainable materials in packaging, manufacturing and construction. The ability to recycle an empty package may not be the primary reason the consumer makes a purchase, but it is an increasingly valid aspect of a consumer's decision making.

Similarly, a growing interest in natural products and healthy ingredients has influenced the information that is conveyed in visual communications, such as in the packaging of food and beverages. 'Sugar free', 'dolphin friendly' and 'organic' are all terms that attract people to particular products and services. In designing for an audience, designers need to be aware of social change and public opinion.

The application of media, methods and materials is often related directly to the content of a visual communication. The choices made by a designer may be based on the most suitable means of conveying a message or representing an object.

As with the analysis of design elements and design principles, it is essential to ask why the selection of media, methods or materials has been made and what effect that choice has on the visual communication. What does the application of a particular medium, method or material provide visually that others cannot? For example, the use of photography dominates contemporary visual communications, so

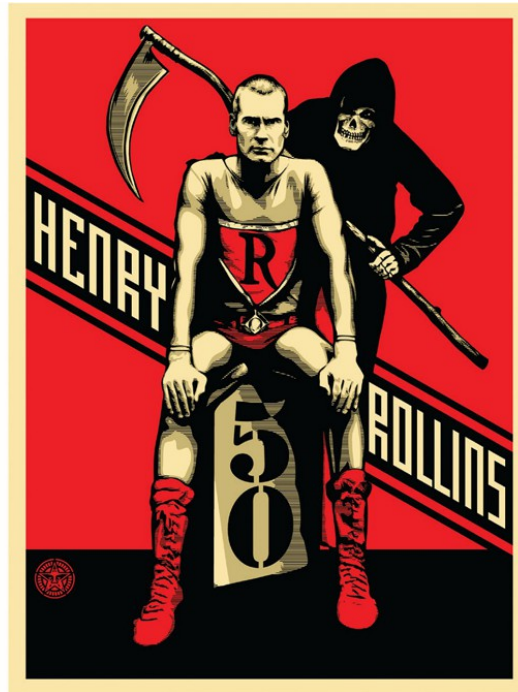

Illustration courtesy of Shepard Fairey/Obeignant.com

- ▲ This poster for musician, author and spoken-word performer Henry Rollins is a computer-generated illustration designed to convey a vintage aesthetic. The poster conveys the textures of a 'woodcut' printing technique that underpins its vintage visuals, and the final design is reminiscent of old carnival or circus posters. In this instance, the selection of materials is to generate a visual style.

it is important to analyse why photography has been selected as the chosen medium as well as analysing the appearance of the imagery itself. Ask yourself questions regarding the composition, the use of cropping and the application of ICT to emphasise or manipulate imagery.

It is relevant to analyse the selection of materials in three-dimensional objects as well as in two-dimensional objects. In fact, the materials and methods used in three-dimensional objects may be more easily recognisable and identifiable.

## Sample analysis of materials



'The Centre for Contemporary Photography (CCP) is a photographic gallery located in the inner-Melbourne suburb of Fitzroy. The entrance and interior of the gallery were designed by architect Sean Godsell in 2005. The original building was an auto garage and the budget for the gallery renovation was limited. The interior of the CCP is simple and bare. Plaster is used on the walls for display, which creates a plain surface, ideal for the exhibition of photographs. The smooth, white surface provides a background that does not compete with the imagery placed upon it. The plywood ceiling is painted white but maintains a visual texture through the addition of circular holes – the use of the plywood materials would make such a feature relatively inexpensive. The concrete floor contrasts with the plainer walls and ceiling, creating a subtle contrast with both. Additionally, it maintains a link to the original purpose of the building.'



Chen Wei, 'The Club', 2017, installation view; photos: J. Froysyth



CCP Gallery, One and Bookstore, 2005; photo: Paul Knight

### Helpful phrases when analysing the media, methods and materials of a visual communication

'The [visual communication] can be [has been] manipulated through the use of [media, methods materials] ...'

'This application of [media, methods and/or materials] signifies ...'

'This [visual communication] uses a more conventional and economical combination of ...'

'[description] is perfectly suited to the [visual communication's] contexts and purposes.'

'A sense of [description] is communicated through [the visual communication's] descriptive colour palette (or other element/principle/media).'

## CHAPTER RECAP



- 1 Explain the following terms and phrases.
  - + UX design
  - + Ergonomic considerations
  - + Accessibility
  - + Emotive imagery
  - + Visual metaphor
  - + Audience characteristics
  - + Usability testing
  - + Trend forecasting
  - + Visual device
  - + End user
  - + Human-centred design
- 2 Collect examples of the following visual communications:
  - a visual communication designed to shock
  - b visual communication that uses metaphor
  - c visual communication that uses humour
  - d visual communication that uses emotive imagery.

Explain how the use of such imagery assists in conveying the purpose and message of each visual communication.
- 3 Collect six recent movie poster designs. Watch the trailer for each film. Analyse the application of design elements and design principles and suggest how they assist in conveying the meaning, theme or content of the film.
- 4 Magazine covers can provide a lot of information about their target audience. Collect a selection of magazine covers and analyse the target audience of each. (See example at right)



istock.com/OSTILL

- ▲ ‘This magazine would appeal to men and women aged 30–50 who enjoy keeping fit and participating in triathlons. Their interests may include sports, fitness, cycling and outdoors and they may aspire to elite levels of competition. Located in Australia and New Zealand, the target audience may seek information and images related to competitions at home and internationally. They are likely to have a high disposable income due to the high cost of triathlon equipment and the need for travel. They may also have access to the time and support needed to train for events.’





PART C

# DESIGN FIELDS AND CONTEXTS

# DESIGN FIELDS

CHAPTER

11

## In this chapter:

- + Visual communication design industry practice..... 242
  - » Freelance designers..... 242
  - » Design studios..... 242
  - » In-house designers ..... 242
  - » The design process in professional environments ..... 243
  - » Research ..... 243
  - » Design and production..... 244
- + Design field: Communication design..... 246
  - » What do communication designers do? ..... 247
  - » What specialist skills do communication designers have? ..... 248
  - » Who do communication designers work with? ..... 248
  - » What resources do communication designers use? ..... 248
- + Design field: Industrial design ..... 249
  - » What do industrial designers do?..... 249
  - » What specialist skills do industrial designers have?..... 250
  - » Who do industrial designers work with?..... 251
  - » What resources do industrial designers use?..... 251
  - » What technologies do industrial designers use? ..... 253
- + Design field: Environmental design ..... 253
  - » What do architects do?..... 255
  - » What do interior designers do?..... 255
  - » What do landscape architects do? ..... 255
  - » What specialist skills do environmental designers have? ..... 256
  - » Who do environmental designers work with?..... 256
  - » What resources do environmental designers use?..... 256

## Learn the language

client	practices	skills	studio
freelance	process	specialists	

You will find helpful tasks related to design fields in Chapter 11 of *Nelson Visual Communication Design VCE Units 1–4 Workbook, Edition Three*.

# VISUAL COMMUNICATION DESIGN INDUSTRY PRACTICE

Three main design fields are identified in the VCE Visual Communication Design study: industrial design, environmental design and communication design. Each design area has its own language, traditions, origins and influences that distinguish it from other professional fields. Designers in all areas follow best practice processes to make the most efficient use of time, **skills** and resources. This chapter goes some way towards explaining the skills, responsibilities and design processes applied by design professionals.

Design is a fluid professional field and designers may find themselves working independently or within a team at different times in their career. Similarly, many designers work across disciplines, combining product and interior design, architectural design and landscape design, graphic design and multimedia design. Design is a profession that is dynamic and ever changing.

However, designers work in a range of professional configurations; three of the most common contexts are as **freelance** designers, **studio**-based designers and in-house designers.

## FREELANCE DESIGNERS

Freelance designers are individuals who work independently rather than as an employee of a design business or other organisation. Often, freelancers operate as a one-person firm, the smallest of small businesses. They may work from a home-based office or in a shared studio with other professionals. Freelance designers, illustrators, photographers, animators and other creative professionals acquire work from direct contact with clients or as an external contractor, employed by an advertising agency or design firm on a short-term basis as part of a larger team.

A freelance designer is usually responsible not only for their creative output but also for the administrative aspects of their business, such as finance, tax and all communications. For many, the appeal of freelance work lies in its autonomy and independence but, as with many small and single-person businesses, the

working conditions are dependent on the amount of work available.

## DESIGN STUDIOS

Many designers work for studios, which can vary in size from small partnerships to large organisations. Within a design studio, the designer rarely works alone on a project, and is often part of a large team. The team may include a creative director or project manager whose role is to manage both the project itself and the professionals involved in the project's development and production. A design team may consist of designers, administrative staff and support staff, as well as external contractors and consultants. Contact with the client may be restricted to the creative director, project manager or partner of the studio, who will then pass on the client needs and details of the brief to the larger team, usually at team meetings.

A team structure provides a creative network for the flow of ideas and possible concepts, and facilitates feedback and evaluation. Unlike freelancers, designers who work for design studios are often provided with administrative support, thereby enabling them to focus entirely on the creative aspects of the design process.

## IN-HOUSE DESIGNERS

Large organisations often employ designers to manage design tasks in-house. Many government organisations and private companies have full-time design teams working as an integral part of the company. Companies, such as automotive manufacturers or film production companies for example, require the services of designers as an essential part of their product design and development.

Although the main focus of a company or organisation, such as a hospital or airport, may be fundamentally unrelated to design, there is often a requirement for the design and production of materials for promotion, employee training, shareholder information and the like. Some organisations may need designers to produce annual reports, signage, newsletters and training materials.

Although many companies and organisations outsource work to independent design firms, for large projects, such as corporate identity design, they often employ in-house designers to manage the ongoing

application of that identity and to produce company- or organisation-specific materials.

Irrespective of the variety of approaches and professional circumstances, there are many similarities in the way professional designers approach key aspects of the design process.

## THE DESIGN PROCESS IN PROFESSIONAL ENVIRONMENTS

### The design brief

The design brief is the starting point of the design process for professional designers in all design areas, and the nature and detail of that brief can vary widely. A client may sometimes approach a designer with a detailed description of a design need, but more often, the client simply has an idea and is depending on the designer to assist in expanding and clarifying the feasibility of that idea. Designers may also gain project work by submitting an application to a client, known as a tender proposal. A client may receive numerous proposals from different design firms; within each proposal there is information on design ideas, costs and a timeline. To determine the most appropriate designer for the task, a client may request a 'pitch' where the designer presents their ideas and proposal to the client directly.

In the early stages of the design process a designer will spend time with a client to gain a clear and detailed understanding of the client's needs and to ascertain whether a suitable working relationship can be established. Designers should listen carefully to the needs of the client, and it is at this stage that a mutual understanding of both the nature of the work and the fee is negotiated.

It is in the designer's interest to ensure that the brief is detailed, contains all of the necessary information and provides a clear direction for the designer. Key questions that designers ask at this stage include the following: What does the client want to achieve? What are the expectations? What are the client's criteria for success? What is the budget? What is the preferred timeline? Is it realistic? What existing material – such as imagery, content and detailed market research analysis – is available?

Client contact continues throughout the design process. Many designers require that clients accept each stage of the process by signing off (i.e.,

approving) the work carried out so far. Formal client approval is particularly important on large projects, where the cost of the client changing their mind can be extremely high. Conditions covering changes to the contract or brief are usually established at the beginning of the process.

The scale of the task is often influenced by constraints, such as the cost, time and the context of the final visual communication, as well as the specific needs of the client. Constraints are usually clarified at the beginning of the design process but they can arise at any time. Consequently, the design process is never static and remains flexible.

Some designers use a return brief at this stage of the design process. This involves the designer writing a brief based on information gathered from the client at initial meetings. The return brief is then sent to the client as the designer's interpretation of the client's need. With further discussion, a final design brief can be established that suits both the client and the designer.

In general terms, the brief is about definition and clarification. In defining the actual needs of the client, the target audience and the purpose of the final design, a designer can gain the clear and concise direction they require.

## RESEARCH

Once the brief has been clarified, the research phase is undertaken. Research can take several forms, and may include client research and audience research.

### Client research

Designers may need to research the client background to establish a clearer understanding of their current needs in the light of their previous history. In many instances, the client may be a large organisation with a well-established corporate or organisational 'culture'. Just like any other social structure, a company is made up of history, hierarchy and traditions. These affect not only the way the company works, but also the way people respond to and recognise it and its reputation within the wider community. Research into the background of a company is often an important aspect of a design brief. Understanding the company can lead to a clearer understanding of what the company or client needs. If a client wishes to alter the culture of the organisation through changes to its brand, processes, location, manufacturing, services or products,

a designer needs to understand not only the changes that need to occur but also why those changes need to occur. An understanding of the client can be just as important as an understanding of the purpose, target audience and context of the finished visual communication.

### Key questions for client research

Who is the client?  
 What does the client do?  
 What is the size of the company or organisation?  
 What size is it perceived to be by the public?  
 What values is it perceived to hold?  
 What is the corporate culture perceived to be?  
 Designers will look at the design history of a company and establish the background of previous design work.  
 What are the existing graphical products used by the client?  
 Is there a corporate style?  
 What is the existing style or aesthetic?  
 How does the client feel about previous designs?  
 What other designs does the client like, both in and outside their field of interest?

### Market research

In some instances, clients who have the resources to do so will undertake extensive research into their target audience. Specialist market research companies and social or trend forecasters act as consultants, gathering and analysing information about a specific market and/or general social trends.

### Key questions for market research

Who is the audience?  
 Who falls within the company's or organisation's existing market?  
 Who does the company perceive as the target market for the new visual communication?  
 Is this a different or new market for the company? If so, why?  
 What are the company's primary and secondary target markets? (For a product aimed at teenagers, for example, the teenagers themselves are a primary market and the parents who will pay for the item are a secondary market.)  
 What research has been done to establish this market?  
 What are the details of the market? (These include age, income, background, interests, purchasing

patterns, ethnicity, location, familiarity with product, technological knowledge, etc.)  
 What other products appeal to this market?

### Other research

In researching the design brief, designers look to a range of resources and material for information and inspiration. These sources include market research, current trends and the work of other designers in the same or similar fields. Research is important throughout the design process and covers not only the appearance or form of the final design but also materials, methods of production and advances in technology.

Ongoing self-education is important for designers, as changes in fashion, technology, social attitudes and world events all impact on design. Books, magazines, journals and the Internet provide imagery and information that help to maintain a designer's awareness of change. Some design magazines produce an annual edition giving an overview of the year. These publications offer an insight into trends and the application of materials and technology.

Conferences, trade events and seminars give designers the opportunity to observe and discuss innovation and trends in design. Worldwide conferences may be specific to a particular area of design or may offer an overview of current and proposed methodology. Conferences offer networking opportunities for designers and provide a forum for discussion and the sharing of opinions and ideas. Online forums and articles also provide the opportunity to communicate with others working in the same or similar fields.

## DESIGN AND PRODUCTION

Although many designers are multiskilled and competent in a range of creative areas, they sometimes call upon the skills of **specialists** within their organisation or as external contractors. Throughout the design process, therefore, the designer interacts with any skilled professionals whose expertise may be required in the design and production stages.

The skills of a photographer or illustrator, for example, may be called on during the development of a graphic design, or the expertise of a printer or Web designer may be required during the final stages of the design process.

## Specialist professionals

3D modeller	Printer
Animator	Project manager
Artist	Standards tester
Builder	(for Australian and
Engineer	international Standards)
Illustrator	Stylist
Model maker	Tradesperson
Photographer	Web designer
Photoshop artist	

Sales representatives and agents who communicate with designers provide information about developments in materials, processes and technologies. Such information may have an impact on the outcome of a design process.

## Teamwork

The degree of interaction between professionals may vary according to the demands of the design brief. Designers working within teams will often collaborate on key aspects of the task. This is particularly valuable for sharing ideas and discussing the various directions a design concept might take.

Freelance designers, although working independently, rarely work in a vacuum. They will often be involved as an external provider to an existing team, offering a particular area of expertise, or they may answer to an **art director** or project manager.

## Ethical and legal issues in design

As in any professional area, designers need to consider the legal and **ethical** issues that affect their field. As professionals they have responsibilities towards their clients, users and the wider community (see Chapter 13 for more information about legal and ethical responsibilities in design).

These issues include the following:

- + attribution
- + copyright
- + cultural sensitivities
- + image manipulation
- + plagiarism
- + safety
- + sustainability.

## The design process

Methods of developing ideas and concepts vary greatly and are dictated by the individual skills of the

design professional. Approaches vary from designer to designer and from design team to design team. Some designers begin their design process with thumbnail sketches and rough drawings, while others feel more comfortable using a computer as an initial tool. Word lists, discussions and models are used widely in the planning of a design strategy.

Client involvement in the design process also varies from project to project and designer to designer.

In the application of design elements and principles, many designers use team feedback to judge the effectiveness of their concepts. Methods of evaluation vary but peer approval is often a powerful influence on decision making. Initial concepts may also be tested on small groups picked from the target market in order to test the effectiveness of the design direction. Feedback is analysed and fed into the continuing design process.

The materials used by designers are dictated by many factors and are as varied as the design briefs. The constraints of the brief – such as time, materials, costs and location – will affect the application of materials, as will less tangible factors. These include the preferences of the client and external influences such as planning restrictions or public sensibilities.

Manufacturing capabilities, access to materials and the availability of technology are other factors that will determine production methods and materials.

## Evaluation

In evaluating the final concept, designers might use a range of methods. In some instances, formal criteria will be used to assess the success of a design. Criteria may have been set within the brief or – in the case of many manufactured products – may exist as part of an established industry standard. Evaluation is often based on subjective factors such as the aesthetic appeal of a design and its appeal in the target marketplace. Tangible factors such as sales figures and financial turnover provide more concrete indicators of the success of a design.

At the conclusion of the design process, some designers may remain involved in a management role. As part of ongoing project management, many designers produce special documentation, style guides and manuals that detail the function, use and application of the finished design. Such guides enable the original integrity of the design to be maintained even without the continued presence or involvement of the designer.

# DESIGN FIELD: COMMUNICATION DESIGN

The origins of communication design (also called graphic design) lie in the developments of typography in Europe from the 15th century onwards. The creation of the printing press and ‘movable type’ enabled mass production of printed materials and radicalised the way the written word was distributed. However, the design of graphic materials was not established as a separate and recognised practice until the early 20th century when attention began to be paid to the composition and layout of books, posters and other printed matter.

Kleine DADA Soiree, 1923 (colour litho), Schwitters, K. (1887–1948) & Doesburg, Theo van (1883–1931)/Art Gallery of New South Wales, Sydney, Australia/The Bridgeman Art Library © Kurt Schwitters/VG Bild-Kunst. Licensed by Viscopy, 2017

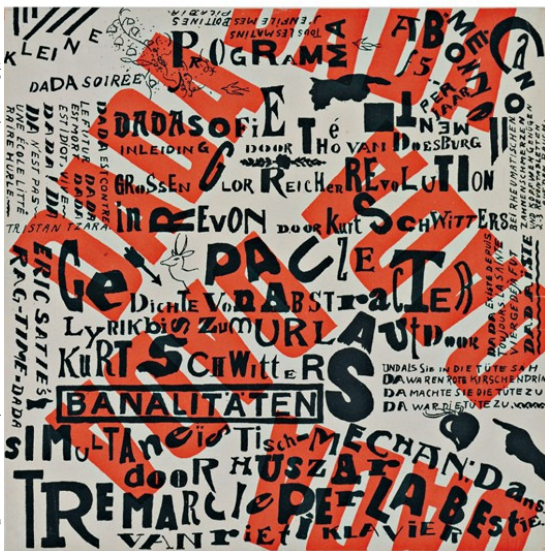

▲ *Kleine Dada Soiree* (Small Dada Evening), poster by Theo van Doesburg and Kurt Schwitters, 1923.

The position of communication design as a respected profession occurred later still, in the 1950s, when the design principles of the International Style were reflected in the corporate logos, film posters and publication designs of the era. Highly influential designers, such as Saul Bass, Paul Rand and Milton Glaser, were seen as pioneers of modern communication design and established many of the fundamental elements and principles of design that are in use today, such as the use of Swiss typefaces including Helvetica, the use of white space and grid systems.



Getty Images/Swim Ink 2, LLC/CORBIS/Corbis

▲ Before its evolution as a design field until the late 1950s, printed materials often featured imagery created by artists and illustrators.



Getty Images/Movie Poster Image Art

▲ This movie poster was designed in 1966 by Saul Bass. He is recognised as one of the pioneers of modernism in communication design.

The rise of communication design as a profession saw its significance explode in the late 20th and early 21st centuries. It was during this time that the significance of logos and corporate branding grew. Communication designers were sought after to create corporate identities for businesses, government and the not-for-profit sector. A recognisable visual identity and brand become essential for organisations in an increasingly competitive and developing marketplace. The role of the communication designer in brand identity, brand development and brand management remains a key aspect of the design area today.

The rise of the Internet from the mid 1990s onwards has seen online visuals evolve from clumsy HTML to sophisticated interactive sites where graphics are designed for user interaction as a priority. The most successful online brands that apply effective user interface design illustrate the skills of talented communication designers. The expanding area of user experience design is established in the realm of communication design. However, access to design software, stock images and social media has meant that the creation of a logo, illustration or graphic is accessible to many, including non-designers, with mixed results.

Communication design is an area where innovation and experimentation have reflected social change, from album covers and rock posters to political slogans and online campaigns, communication design has expressed dissent, new ideas, political affiliations and protests. It has been used to create things of minimal importance, such as memes of disgruntled cats that proliferate on the Internet, to tools of mass change, such as Shepard Fairy's 'HOPE' poster for the 2008 Obama presidential campaign.

The design of visual messages and meanings in our highly visual culture has become integrated into our lives; consider street signage, warning labels and advertising, which serve to inform, instruct and entice viewers respectively. In its short life, the profession of graphic design has become a respected and influential one.



© Metro Trains Melbourne, Dumb Ways to Die™ All Rights Reserved.

▲ One of the most popular public awareness campaigns in history, 'Dumb Ways to Die', included a catchy song, animations and characters to promote safety around trains. The campaign was shared online, won multiple awards and has spawned collectible merchandise.

## WHAT DO COMMUNICATION DESIGNERS DO?

Communication designers work with type and image to create a wide range of graphical products in print and digital media. Common projects for graphic designers include logos and corporate branding, packaging, posters, signage/way finding systems, publication design, Web design and interactive multimedia.

Communication designers work for a range of clients across all business, government and not-for-profit sectors. Their work is diverse and often offers opportunity for creative design solutions. Advertising and corporate branding are two key areas for communication designers. Some communication design studios specialise in branding, offering businesses and organisations a comprehensive design focus to suit their needs.



Designed by Yiyang Lu www.yiyanglu.com

▲ Communication designer Yiyang Lu has a diverse set of skills, from packaging and identity design to illustration and animation.



## Von Glitschka



Von Glitschka is a US-based communication designer who is renowned for his distinctive illustrations and logo designs. Von generously shares his design process in online videos. He is a noted speaker, teacher and designer as well as the founder of the '5ive minute logo'!

Von describes his process for identity design as: 'My general systematic approach is the same on all projects but for a logo design project:

- + quote a project
- + send brief
- + review brief and follow up with more questions
- + sit on project and do my own research and let everything slow boil to formulate ideas

- + draw out any ideas and isolate my strongest directions
- + design close-to-final comps
- + make any revisions necessary
- + set up final art files and style guide
- + design any identity pieces like business card, letterhead, etc.
- + prepare all files for print vendor if needed
- + invoice.'



GlitschkaStudios.com

▲ Identity designs by Von Glitschka of Glitschka Studios.

## WHAT SPECIALIST SKILLS DO COMMUNICATION DESIGNERS HAVE?

Universities and TAFEs offer qualifications in communication design (also called graphic design or visual communication) and each course offers a variety of subjects in areas such as traditional print and digital media, typography, branding and identity design, two- and three-dimensional design, motion graphics, illustration and photography. Designers have opportunities to build knowledge of design theory and analysis as well as practical skills.

In their professional life, communication designers are often multiskilled with abilities in drawing, illustration, and design software, such as Adobe Illustrator, InDesign and Photoshop, and motion-graphics programs. As in other design areas, the ability to communicate well with clients and work with other design professionals is advantageous.

## WHO DO COMMUNICATION DESIGNERS WORK WITH?

Although many communication designers specialise in design areas such as print or digital media, they can be

required to collaborate or seek assistance from specialist practitioners. They may work together as part of a cross-disciplinary team or require the service of a specialist to complete a final design product. Specialists include printers, exhibition and display designers, multimedia specialists and Web designers, game and animation designers, illustrators, photographers, sign writers, industrial designers and advertising art directors.

## WHAT RESOURCES DO COMMUNICATION DESIGNERS USE?

Contemporary communication designers generally use computers for the bulk of their design work. Drawing may still form an important part of the design process, particularly in the early stages when visualisation and ideation are required. However, the main tools used in graphic design are design software packages that includes Adobe Illustrator, Photoshop and InDesign. Motion graphics may be created in Final Cut Pro or Premiere Pro.

Designers often use digital tablets to input and edit design ideas digitally and 2D printing technologies are often used for the proofing of final artwork. Additional resources that might be found in a graphic designer's toolkit are Pantone colour swatches for colour

selection, a camera for collecting research and a library of books and magazines that document contemporary trends in global design.

### Significant communication designers

Milton Glaser	Vince Frost
Paul Rand	April Greiman
Saul Bass	Michael C Place (Build)
Paula Scher	Von Glitschka
Stefan Sagmeister	Stephen Banham

## DESIGN FIELD: INDUSTRIAL DESIGN

Industrial design is an area of design established in the mid-19th century during the latter part of the Industrial Revolution. As a design discipline, the origins of industrial design can be traced back to the influential design movements of the early 20th century in Europe including the Deutscher Werkbund and the Bauhaus. Members of both movements recognised that a formal visual language of function was overtaking the decorative designs of previous art and design movements (such as Art Nouveau). In the chaos of the First World War and its aftermath, designers identified a need for accessible, standardised, simple forms and eschewed the highly decorative and hand built in favour of a streamlined, 'machine aesthetic'.

The Bauhaus was a highly influential design school established in 1919 that promoted a functional aesthetic in all areas of design. Core studies at the Bauhaus focused on the logical analysis of form and function. The use of materials such as steel, Plexiglass®, rayon and even cellophane in design were radical departures from the traditional visual arts training that had gone before. Students were taught to use instruments in their drawings; items such as the compass and the straightedge ruler, which had previously been the tools of engineers and draftspeople, became part of the creative process within the Bauhaus.

The Bauhaus director, Walter Gropius, believed that the making of objects and constructions was an important social and intellectual pursuit, and he encouraged students to follow a functional aesthetic. Studies at the Bauhaus included graphic design,



▲ Bauhaus, Dessau main building designed by Walter Gropius, 1925–26, 'Bauhaus' logotype by Herbert Bayer.

typography, furniture design, architecture, textiles and metal.

The alumni of the Bauhaus influenced design around the world and led to the development of the highly influential International Style, seen as most typical of the clean lines of modernist design. The characteristics of modernism still influence many contemporary industrial designs; the focus on function, the application of clean, unambiguous forms and the innovative use of materials.

Architect and designer Dieter Rams, as chief of design at German company Braun, was highly influential in the design of consumer products. His modernist designs for shavers, audiovisual equipment and small domestic appliances were highly influential and many are still in production today. Most famously, Rams defined 10 principles of good design, which are celebrated as defining effective modern industrial design.

### WHAT DO INDUSTRIAL DESIGNERS DO?

Industrial designers consider form and function to create consumer or industrial products both large and small, including but not limited to motor vehicles, consumer electronics, lighting, furniture, medical equipment, toys, recreational products, industrial machinery and water craft. Most industrial designers strive to create products that are sustainable, efficient and effective by using innovative technologies and materials, principles of design and appealing aesthetics.

Industrial designers are usually conceptual thinkers who are trained to respond to design problems in practical yet creative ways. They are required to work confidently to a design brief in the development of effective, attractive and marketable products, from initial research through to final prototype.

## Dieter Rams



### Good design . . .

**Is innovative.** The possibilities for progression are not, by any means, exhausted. Technological development is always offering new opportunities for innovative design. But innovative design always develops in tandem with innovative technology, and can never be an end in itself.

**Makes a product useful.** A product is bought to be used. It has to satisfy certain criteria, not only functional, but also psychological and aesthetic. Good design emphasises the usefulness of a product while disregarding anything that could detract from it.

**Is aesthetic.** The aesthetic quality of a product is integral to its usefulness because products are used every day and have an effect on people and their wellbeing. Only well-executed objects can be beautiful.

**Makes a product understandable.** It clarifies the product's structure. Better still, it can make the product talk. At best, it is self-explanatory.

**Is unobtrusive.** Products fulfilling a purpose are like tools. They are neither decorative objects nor works of art. Their design should therefore be both neutral and restrained, to leave room for the user's self-expression.

**Is honest.** It does not make a product appear more innovative, powerful or valuable than it really is. It does not attempt to manipulate the consumer with promises that cannot be kept.

**Is thorough down to the last detail.** Nothing must be



Photo © Christie's Images/Bridgeman Images

▲ A radiogram, comprising a turntable, receiver and amplifier, 1959, designed by Dieter Rams

arbitrary or left to chance. Care and accuracy in the design process show respect towards the user.

**Is environmentally friendly.** Design makes an important contribution to the preservation of the environment. It conserves resources and minimises physical and visual pollution throughout the lifecycle of the product.

**Is as little design as possible.** Less, but better – because it concentrates on the essential aspects, and the products are not burdened with non-essentials. Back to purity, back to simplicity.

Dieter Rams

## WHAT SPECIALIST SKILLS DO INDUSTRIAL DESIGNERS HAVE?

In training at university level, industrial designers develop skills in specialist materials and manufacturing, ergonomics and engineering. They undertake three-dimensional design and drawing studies to assist them in experimenting with ideas and documenting their design process. Industrial designers often use design sketching to visualise their early design ideas and this is a key part of their design process. Using pictorial drawing methods,

such as isometric or perspective drawing, designers sketch and render their ideas before venturing into digital media.

Graduate industrial designers may specialise in an area of interest or offer general skills. Specialist designers may include automotive designers, furniture designers and lighting designers. Generalist industrial designers may be required to design a wider variety of products from hair dryers and kettles to gymnasium equipment and water bottles. Manufacturers often approach industrial designers with an idea for a product for which the designer will be engaged to visualise and make real. The ability to

communicate with clients and the ability to interact with other specialists are additional skills that an industrial designer needs to acquire.

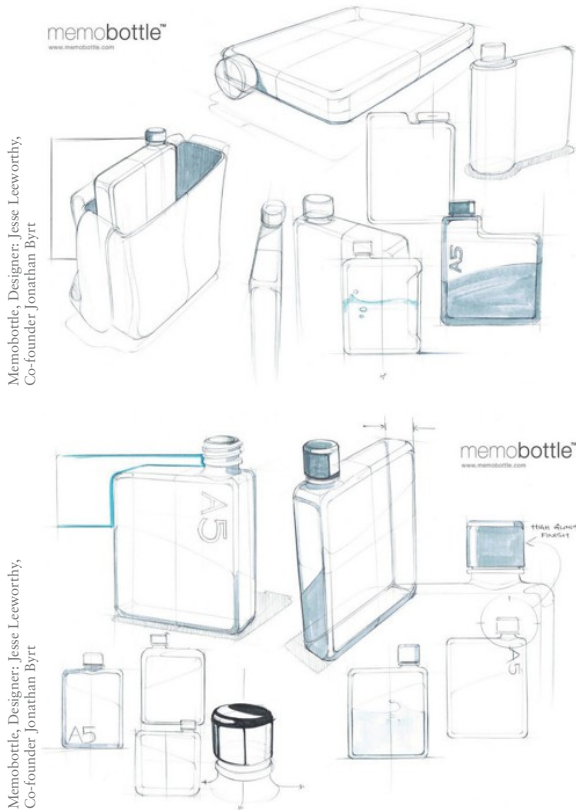

▲ Development sketches of the innovative Memobottle; a significant re-design of traditional water bottles. Industrial designers are highly skilled in visualising product concepts through drawing. Drawing ideas mean that communication of the functions, appearance and forms of products can be visualised prior to the expensive stages of prototyping and manufacture.



▲ The final Memobottle products

ISBN 9780170401784

## WHO DO INDUSTRIAL DESIGNERS WORK WITH?

Industrial designers work with a range of specialists. Although industrial designers often have a comprehensive understanding of how a product works, they also rely on the expertise of others to ensure that needs such as safety, functionality, durability and reliability are met. Working on a small domestic appliance, such as a blender, an industrial designer may need to consult with an electrical or systems engineer whose role it is to create an interactive interface for the product. Engineers often work with industrial designers, bringing their specific technical expertise to projects; the automotive industry, in particular, sees engineers and industrial designers working in close partnership.

Although most industrial designers are required to produce models during their studies, professional projects may see them use the skills of a model maker to create a prototype of a design. Very often, prototypes are used for testing and evaluation before the expensive manufacturing process begins; for example, all new motor vehicle designs are created in clay as part of the design process. Likewise, a specialist 3D digital modeller may be involved in creating digital representations of the final design.

## WHAT RESOURCES DO INDUSTRIAL DESIGNERS USE?

Industrial designers are required to maintain wide knowledge of innovations in materials and technologies. Advancements in materials and manufacturing processes can increase the durability, sustainability and functionality of products so it is essential that designers remain up to date. Designers might access sample materials, attend conferences and seminars, and use online resources and magazines to enhance their knowledge of changes and trends in design.

Product designs are invariably bound by manufacturing standards and regulations. Familiarity with Australian and international standards is essential to ensure that new designs are compliant. Industrial designers need to access information about user-related factors in their designs including ergonomics, interface design and aesthetic preferences. Research is a key component in building knowledge about these factors.

The rise of crowdfunding through sites such as Kickstarter and Pozible mean that designers can propose

Nelson Visual Communication Design VCE Units 1–4

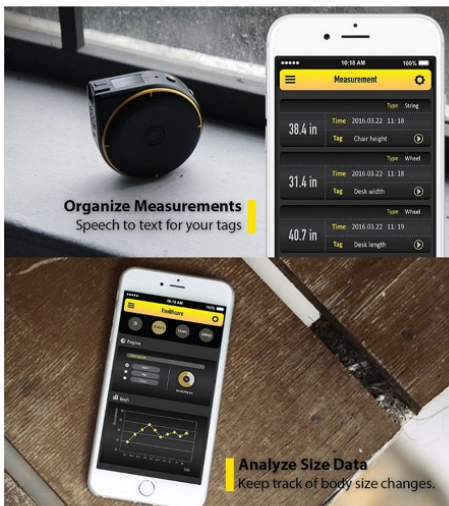
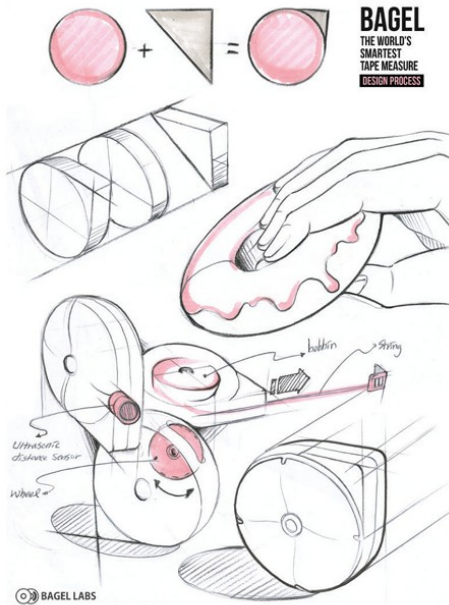

**Remote Mode**  
1" - 36" (1.03m - 10m)

- Built-in Laser Pointer**  
Guides your remote distance measurements.
- Standing Supports**  
Helps you measure perfectly horizontal and vertical distances.

**String Mode**  
0" - 9' 10" (0 - 3m)

- Strong, Flexible String**  
Made of Dyneema string that can withstand up to 112lb.
- Safe for Everyone**  
No more cutting your fingers on metal tape edges.

**Wheel Mode**  
0" - 32" (0 - 10m)

- Measure with One Hand**  
Quickest way to measure length or distance.
- Rolls on Any Type of Surface**  
Great for measuring odd-shaped objects.

▲ Kickstarter-funded products enable investors to see the design process involved in a product design. Once fully funded, designers keep members up to date with progress on the development and manufacture of the product. The Bagel Measure is an example of a Kickstarter success; based on their level of investment, Kickstarter investors were offered early access to the finished product on its release.

and fund products using investment from a wide range of sources. Production requires significant investment and capital; crowdfunding enables small design studios and individual designers to create products outside the traditional model of industrial manufacture.

Similarly, advancement in 3D printing technologies has meant that product designs can be produced on a smaller scale, without investment in machine set-up or 'tooling' for manufacture.

## WHAT TECHNOLOGIES DO INDUSTRIAL DESIGNERS USE?

Industrial designers use a wide range of design technologies from pencils, pens and markers for design sketching to sophisticated CADD software such as Revit, SolidWorks and AutoCAD. They use 2D and 3D printing technologies to create plans and prototypes of product designs and a range of modelling techniques including moulding, forming and constructing to create scale models.

### Significant industrial designers

Dieter Rams	Karim Rashid
Raymond Loewy	IDEO
Marc Newson	Smart Design
Philippe Starck	Hilary Cottam

## DESIGN FIELD: ENVIRONMENTAL DESIGN

The design of environments for human shelter and comfort is evident in much of history. Environmental design, including architecture, interior design and landscape architecture, has a long tradition that links back to ancient civilisations. It is possible to identify cultural and historical change through the appearance and function of architectural structures, interiors, parks and gardens.

Structural and aesthetic developments in architecture, interior design and landscape design are often a reflection of the times in which they were

built. The most magnificent churches and temples were constructed when religious institutions were at their most influential. Castles and palaces were designed to reflect the status and power of those who commissioned them. In more recent times, corporate wealth has often been celebrated by the building of bigger, taller and more imposing office towers. However, not all built environmental design is about imposing structures; domestic architecture has evolved to embrace secure and comfortable dwellings that reflect the aesthetic of their time and location.

Today, we still use many classical architectural conventions that can be traced back to ancient Greece and Rome. Domes, vaults and arches are structural innovations that first appeared more than 2000 years ago, designed by Romans such as Pollio, then rediscovered and refined during the Renaissance by great architects such as Brunelleschi and Alberti.

Designers who have responded to the needs identified by client, location and climate have formed our modern environment over many years. Changing technologies and materials have defined the form, height and appearance of structures. For example, skyscrapers are a 19th–20th century development that evolved from advancements in engineering. In Australia, our built environment has often been defined by climate and lifestyle; the iconic Australian designs of domestic homes, government buildings and parks reflected in Colonial, Federation and tropical architecture, for example.



- ▲ Glasshouse, 1949 by Philip Johnson. The design of the landscape was by David Whitney. The design of Johnson's Glasshouse was inspired by the Farnsworth House by architect and former Bauhaus member Ludwig Mies van der Rohe.



Tower House, Austin Maynard Architects, photography: Peter Bennetts



Tower House, Austin Maynard Architects, photography: Peter Bennetts

**designstrategy**  
**planning**

**design strategy**  
setting 3 clear programme zones allows a simple and effective floor layout, running the services along the south which acts as a buffer between the neighbours and the bedrooms. Moving the living spaces to the north encourages passive solar gain and activates the outdoor spaces.

**parents zone**

**glazed section between forms**

**the houses are separated with a glazed section between them, allowing a slither of light to stream into the house and to accentuate the definition between forms, while also giving you a glimpse of the sky.**

**designstrategy**  
**study tower**

**hangout space**

**study**

**netting floor**

instead of a floor, we can install a netting above the study space, great space to relax and read a book, the netting will also allow light to pass through and filter down to the bottom

Design of the built environment is an area where innovation and experimentation are publicly debated, challenged and celebrated. Developments in materials and construction, shifts in aesthetics and taste as well as changes in urban planning priorities combine to stimulate innovative and confronting spatial designs. Given its highly visible and public nature, this area of design can at times be the most controversial, with many designers required to address the response of the public in addition to clients and stakeholders.

Generational change usually sees cutting-edge built environment **practices** absorbed and adapted over time. For example, Philip Johnson's 1949 steel-framed Glasshouse eschewed solid walls for sheets of glass that embraced the surrounding landscape. At the time, such a design challenged the architectural norms, while the use of glass walls and open-plan spaces are common aspects of contemporary home design today.

## WHAT DO ARCHITECTS DO?

Architects are concerned with creating, enhancing and defining the built environment. Working with space and form, architects work closely with their clients to create environments that meet needs and solve design problems. They work on domestic, public, cultural and private commercial buildings on a small and large scale. Architects generally work as part of a team, with assistance from junior designers and project managers. They work with builders, engineers, site managers and construction industries to see the original design take shape. Their work demonstrates a balance between creative ideas and construction technology. Architects design plans and elevations, using a range of design technologies to create two- and three-dimensional representations of their concepts.

## WHAT DO INTERIOR DESIGNERS DO?

Interior designers work with interior space. They explore how people engage with their environment and using this knowledge, as well as an understanding of building technologies, they create spaces that address functional needs and communicate themes and ideas. Interior designers work on the spaces inside domestic, commercial and cultural buildings using many of the design technologies and drawing methods applied by architects. As well as structural changes

within an environment, interior designers devise solutions for highly varied needs that might include the design of customised furniture or the identification of the most efficient movement through spatial zones. Interior designers also work on exhibition and display design and theatrical productions.

## WHAT DO LANDSCAPE ARCHITECTS DO?

Landscape architects work within the natural environment to create outdoor spaces including parks, recreational spaces, gardens and landscapes associated with major infrastructure systems such as roads. Often working in partnership with architects, landscape architects have deep knowledge of environmental factors such as climate, horticulture and geography. The work of landscape architects is often collaborative and focused on creating designs that are sympathetic and appropriate for the environment, surrounding structures, urban landscape and climate. Like other built environment

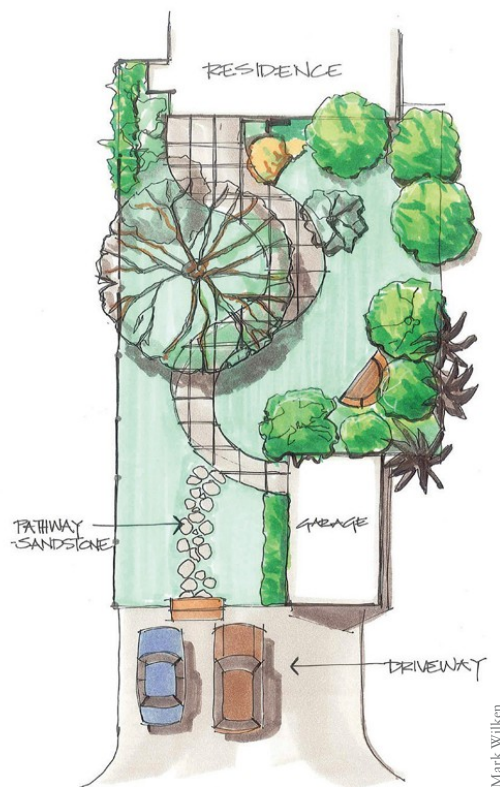

▲ Two-dimensional visualisation sketch of a site plan.



professionals, landscape architects use a range of design technologies to express and develop their design ideas.

## WHAT SPECIALIST SKILLS DO ENVIRONMENTAL DESIGNERS HAVE?

As in all design areas, environmental designers are highly creative problem solvers who have significant knowledge about the technical aspects of their specialised area. They have deep understanding of standards and safety practices and apply these to their projects. Given that they often work in multidisciplinary teams, designers often must be skilled managers and communicators to ensure that projects stay on track and on budget.

Designers in these areas have skills in visualising three-dimensional forms and creating these using both traditional and digital technologies. They are skilled in the presentation of concepts, allowing non-professionals to comprehend the appearance, scale and proportion of a proposed design.

## WHO DO ENVIRONMENTAL DESIGNERS WORK WITH?

Environmental designers work with a wide range of professionals that varies according to the context

and nature of the design projects. Specialists might include model makers, engineers, surveyors, building professionals, tradespeople, drafting professionals, horticulturalists, and lighting and building automation specialists among others. A shared language and use of appropriate terminology is important in built environmental design because it facilitates the communication of ideas between key parties involved in the design and construction of a project.

## WHAT RESOURCES DO ENVIRONMENTAL DESIGNERS USE?

Environmental designers use a range of technologies including the traditional drawing techniques. Although fewer designers use drawing boards to hand-draw plans, it is not unheard of. Drawing, as in other design areas, is the best method to quickly 'ideate' or visualise design ideas. Sketches may be done by hand or by tablet on a screen.

Digital technologies are commonly applied in all areas of built environmental design. CADD software enables designs to be explored and analysed in detail before undertaking an expensive construction process. Technical specifications, lists of materials and fittings, finishes and fixtures are outlined in the planning stages of the design process and contained within plans and specification documentation.

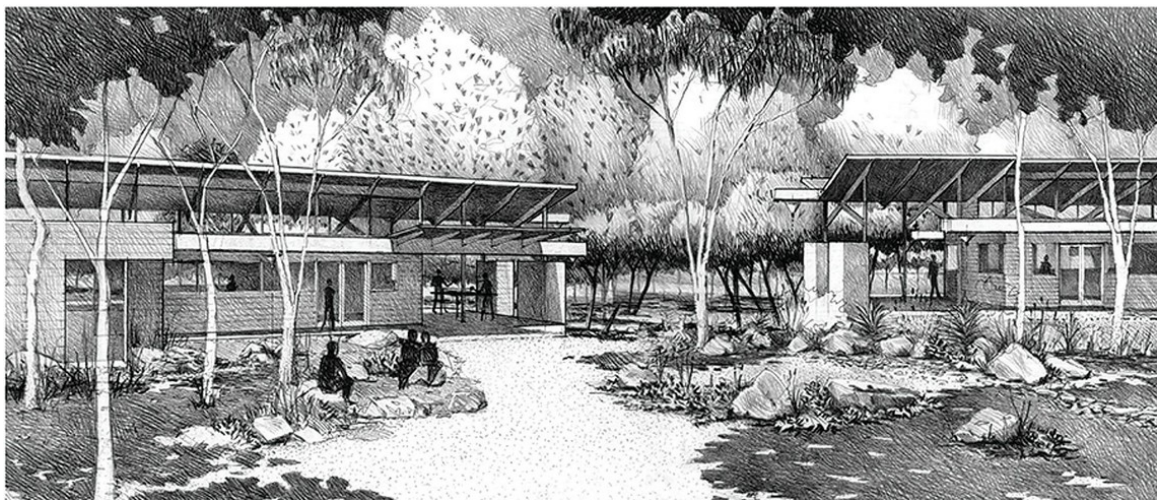

▲ Using both digital and traditional drawing methods, environmental designers translate concepts and plans to three-dimensional drawings to help the client visualise the finished structure.

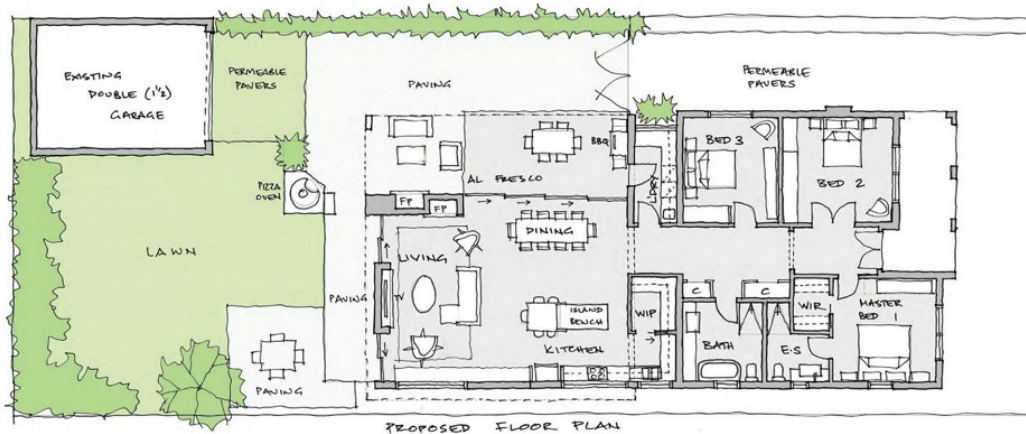

	Project Customer + Location:	Drawing Description:	Drawing #:	Services Provided by:	Drawing Notes: This is a developed design drawing showing a general layout for discussion purposes only. Not for Construction. No warranty is given as to the precision of the dimensions indicated or illustrated. The customer is invited to use this sketch design space payment of architectural fees. This license is non-transferable. The design and drawings shall not be reproduced, published on the internet or traced without the permission of My Architect (Melbourne). © My Architect
		Schematic Floor Plan Options	SK01 Date: 19 Mar '16 Scale: 1:100	My Architect (Melbourne)	

Lyndal Williams, My Architect Australia

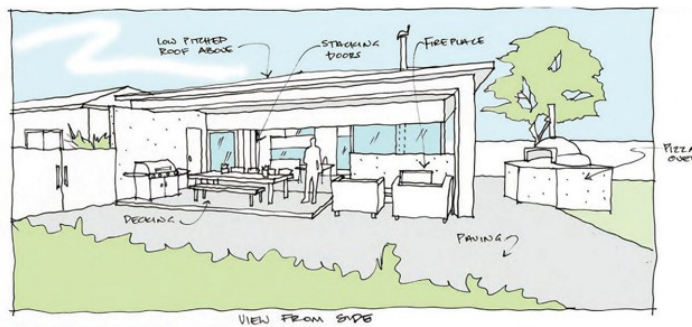

	Project Customer + Location:	Drawing Description:	Drawing #:	Services Provided by:	Drawing Notes: This is a developed design drawing showing a general layout for discussion purposes only. Not for Construction. No warranty is given as to the precision of the dimensions indicated or illustrated. The customer is invited to use this sketch design space payment of architectural fees. This license is non-transferable. The design and drawings shall not be reproduced, published on the internet or traced without the permission of My Architect (Melbourne). © My Architect
		Schematic Floor Plan Options	SK02 Date: 19 Mar '16 Scale: 1:100	My Architect (Melbourne)	

Lyndal Williams, My Architect Australia

- ▲ Architects at My Architect, an Australian firm, make drawings during early-stage client meetings to help communicate design ideas and ensure that architect and client are visualising similar concepts. Annotated two-dimensional and three-dimensional drawing methods are used to assist in clarifying design directions before time-consuming plans and digital designs are created. Drawing is the speediest method of consultation.

## ▼ Visual communication design industry practices

Design field		Research	Skills
<b>Communication design</b>	Communication designer	<ul style="list-style-type: none"> <li>Observation of behavior, environment</li> <li>Books</li> <li>Internet</li> <li>Site visits</li> <li>Photographs</li> <li>Past experiences</li> <li>Market research</li> <li>Seasonal trends</li> <li>Client history</li> <li>Market history</li> </ul>	<ul style="list-style-type: none"> <li>Communication skills</li> <li>Drawing skills</li> <li>Computer skills (esp. Photoshop, Illustrator and InDesign)</li> <li>Visualisation skills</li> <li>Skill in the selection of appropriate materials and media</li> <li>Organisational skills</li> </ul>
<b>Industrial design</b>	Industrial designer	<ul style="list-style-type: none"> <li>Sample materials</li> <li>Similar products</li> <li>Observation and analysis of competitor products</li> <li>Observation of user behaviours and habits</li> <li>Environmental factors</li> <li>Safety and manufacturing standards</li> <li>Ergonomics</li> </ul>	<ul style="list-style-type: none"> <li>Practical modelling skills</li> <li>Computer skills (esp. 3D)</li> <li>Skill in the use of appropriate technical language/terminology</li> <li>Organisational and planning skills</li> </ul>
<b>Environmental design</b>	Architect	<ul style="list-style-type: none"> <li>Site visits and evaluation (site analysis)</li> <li>Books</li> <li>Magazines</li> <li>Internet</li> <li>Observation of location</li> <li>Environmental and historical area research</li> <li>Analysis of client's needs</li> <li>Existing and historical buildings</li> <li>Restrictions, standards and regulations</li> </ul>	<ul style="list-style-type: none"> <li>Drawing</li> <li>3D model construction</li> <li>Project management (e.g., planning, budgeting)</li> <li>Understanding of materials</li> <li>Ability to read and understand plans and technical drawings</li> <li>Skill in the use of appropriate terminology</li> <li>Understanding of building standards</li> </ul>
	Interior designer	<ul style="list-style-type: none"> <li>Observation</li> <li>Books</li> <li>Magazines</li> <li>Internet</li> <li>Observation and analysis of the space/environment</li> <li>User observation</li> <li>Existing style of the building/space</li> <li>Trends</li> </ul>	<ul style="list-style-type: none"> <li>Visualisation skills</li> <li>Good taste</li> <li>Ability to create themes and integrate varied design elements</li> <li>Interpretation of trends</li> <li>Drawing skills</li> <li>Management of varied materials and elements together</li> </ul>
	Landscape designer	<ul style="list-style-type: none"> <li>Climate</li> <li>Landforms</li> <li>Soil quality</li> <li>History/background of the site</li> </ul>	<ul style="list-style-type: none"> <li>Horticultural knowledge</li> <li>Environmental knowledge</li> <li>Drawing skills</li> <li>Skill in interpretation of plans</li> </ul>

Specialist practitioners	Decision making	Evaluation techniques	Legal and ethical considerations
Photographer Printer Web designer Copywriter Illustrator Animator Photoshop retouch artist Typographer	(All designers) Reading the brief assists in making appropriate and correct decisions. Understanding and applying the constraints of the task as outlined in the design brief The testing of materials and media to ascertain the most appropriate outcome Testing and experimentation with colour options and thematic issues Decision making based on issues such as:	Through the use of a mock-up or rough draft The success of the design based on sales or statistics before and after the completed design The use of post-design analysis to determine client satisfaction and usability of the product/design Referral to other jobs due to success Use of user questionnaires and market research	Attribution Copyright Cultural sensitivities Image manipulation Plagiarism Sustainability
Model maker 3D computer modelling artist Engineers (e.g., electrical, systems) Manufacturer Toolmaker	+ suitability + durability + ergonomics + environmental impact + cost + sustainability. Decisions are made based on the appropriateness to the target market. To determine whether a design is positioned correctly can be established through market testing.		Safety Building regulations Sustainability Plagiarism Contractual legalities
Model maker Builder and construction professionals Computer 3D artist Interior designer Engineers (e.g., structural) Draftsperson Planning professionals			
Architect Tradespeople (e.g., painters, upholsterers) Lighting designer Textile designer		Client satisfaction The use of post-design analysis to determine client satisfaction and usability of the space/design Referral to other jobs due to success	Safety Building regulations Sustainability Plagiarism Contractual legalities Attribution
Architect Interior designer Horticulturalist Nursery worker		Success can be visibly seen in successful planting and survival	

Research is an important aspect of environmental design. All designers will undertake a site survey to ascertain the qualities and characteristics of the location of the construction, landscape or interior. Site analysis can identify issues such as privacy, challenging landforms and planning restrictions. Aerial photography may also be ordered to allow for a comprehensive visual understanding of the site. An investigation of regulatory requirements (ResCode, the Building Code, planning regulations, building regulations, etc.) is undertaken to determine restrictions and requirements set by local authorities.

### Significant environmental designers

Frank Lloyd Wright	Sir Norman Foster
Harry Seidler	Patricia Urquiola
Walter Burley-Griffin	Sean Godsell
Zaha Hadid	Thomas Heatherwick
Frank Gehry	Cassandra Fahey

## CHAPTER RECAP



A designer is contacted by a potential client, for an initial meeting. Suggest what information the designer may need to ascertain from the client in the following scenarios:

### Industrial design

'I am a business owner and I specialise in developing products for the home market. We sell a range of plastic products including storage. We wholesale our products to large bricks and mortar retailers such as Big W and Kmart and online retailers such as Amazon. We want to develop a range of lunchboxes for families to use. We want to create storage options that can be interchangeable and offer safe and secure storage for liquids and perishables.'

### Communication design

'I am a plumber with a medium-sized and very successful business. I am looking to expand my business and set up a website that can be viewed

on a range of devices including mobiles/tablets, etc. I want a uniform for the people working for me, graphics for my trucks and branding of all my promotional materials. My business is based in Melbourne but we service the outer northern suburbs. We want to be highly visible.'

### Environmental design

'I am the mayor of the local shire and I am committed to encouraging the use of outdoors recreation areas and parklands in the region. I have established a committee to address issues around this and we require the design of a park/recreation area that incorporates activities and experiences for people of all ages to enjoy. There should be options for young children to play safely but also for others to enjoy the environment. Some shelter should be included in the design.'

- + What information do you need from the client?  
*Focus on information that is specific to your chosen design field.*
- + List five questions that you might ask the client at the first meeting.
- + What research might you need to undertake before you begin the generation of design ideas?
- + List three different research resources/ methods that you might use.
- + At what other stages during your design process might you need to communicate with the client?
- + How might you begin developing ideas for the design?
- + How might you evaluate the success of the final design?
- + List two ways that you can evaluate the success of the identity design.
- + How will you make a decision about which designs to refine further?
- + Investigate the possible production methods relevant to your chosen scenario.



# DESIGN IN A WIDER CONTEXT

## CHAPTER 12

---

### In this chapter:

+ The historical context .....	262
+ Key movements in design .....	262
» Design history timeline, 1850–current day.....	263
» Identifying historical connections .....	279
+ Economic and political factors in design .....	280
» Economic influences.....	280
» Political change.....	281
+ The social context of design.....	282
+ Culture, religion and design .....	283
+ Technology and design .....	283
+ Design and the environment .....	284

### Learn the language

collaboration	influences	movements	reaction
culture	modernism	postmodernism	styles

You will find helpful tasks related to this area of visual communications in Chapter 4 of *Nelson Visual Communication Design VCE Units 1–4 Workbook, Edition Three*.

---

Visual communications are a reflection of their time, and often depict the fashion, taste and trends of a period. The impact of social change can be clearly seen in many areas of design, including fashion, architecture, graphic design and product design. As public sensibilities change, so too do the boundaries of visual language. What was confronting imagery 30 years ago may be quite acceptable today.

Design trends often reflect historical references and past artistic traditions, so it is possible to see references and **influences** in many contemporary visual communications. We can revisit examples of visual communications and recognise that advances in technology, media and materials have had an enormous impact on contemporary design.

Materials and media used in the production of visual communications change due to the influences of new technologies and concerns about ongoing environmental impact. Design innovation is often seen hand in hand with the development of new materials.

The application of design principles and elements is particularly susceptible to changes in fashion and taste. Illustrations or symbols and their colours and shapes, for instance, may change over time as they acquire political or cultural significance beyond their original purpose.

## THE HISTORICAL CONTEXT

There are recognisable links and influences that flow through the history of visual communications. The development of designs does not occur in a vacuum, and many designers take the historical successes or failures of earlier designs into account when developing new concepts. Designers understand that to create something new, they must look to a range of sources, including designs of the past.

Historical influences on design can be subtle, perhaps even imperceptible. A designer may look at past designs and analyse examples as part of research. What aspect of the design succeeded? What failed? What appealed to the target audience? Answers to these questions can help designers to avoid repeating mistakes and lead them to focus on expanding the successful elements of a previous design.

Some designers incorporate their historical references more obviously than others. Fashion trends often refer to past **styles** and **movements** for inspiration,

creating garments and textiles with obvious links to past styles, and the same thing happens in communication design. Retro – a colloquial term used to describe a style of design, fashion or music that blends aspects of previous styles – actually means ‘backward looking’, and it is possible to trace the origins of many contemporary designs that look back into the past.

Designers look to historical sources for:

- + inspiration and ideas for new design concepts
- + information about techniques and methods of production
- + analysis of successes and failures as reference for design concepts
- + classic use of design elements and design principles that have endured and remain effective
- + visual motifs and concepts that emulate an era, style or historical climate.

## KEY MOVEMENTS IN DESIGN

To understand some of the historical influences that affect contemporary design, it is valuable to have a general grasp of key design developments over the past 150 years. Many excellent reference books present detailed information about design movements, from the Arts and Crafts Movement of the 19th century to **postmodernism** and design in the digital era. The Internet also offers many websites that feature design timelines and profiles of significant designers in every field.

For the purposes of the Visual Communication Design study, we will look at some key movements and designers of the past to develop an understanding of design history and its continued impact on contemporary design. This is a brief overview of historical styles and it is recommended that you expand your knowledge by reading some of the many books and websites that offer rich information about design history.

Major developments in design occurred after the Industrial Revolution of the 18th and 19th centuries; a period of immense change in agriculture, manufacturing, mining, transportation and technology that had a massive impact on the social and cultural makeup of Western society. The 19th and 20th centuries saw significant change in the way visual communications were produced. The mechanisation of manufacturing processes, the rise of factories and the growth of global markets ushered in major changes in how products

## DESIGN HISTORY TIMELINE, 1850–CURRENT DAY

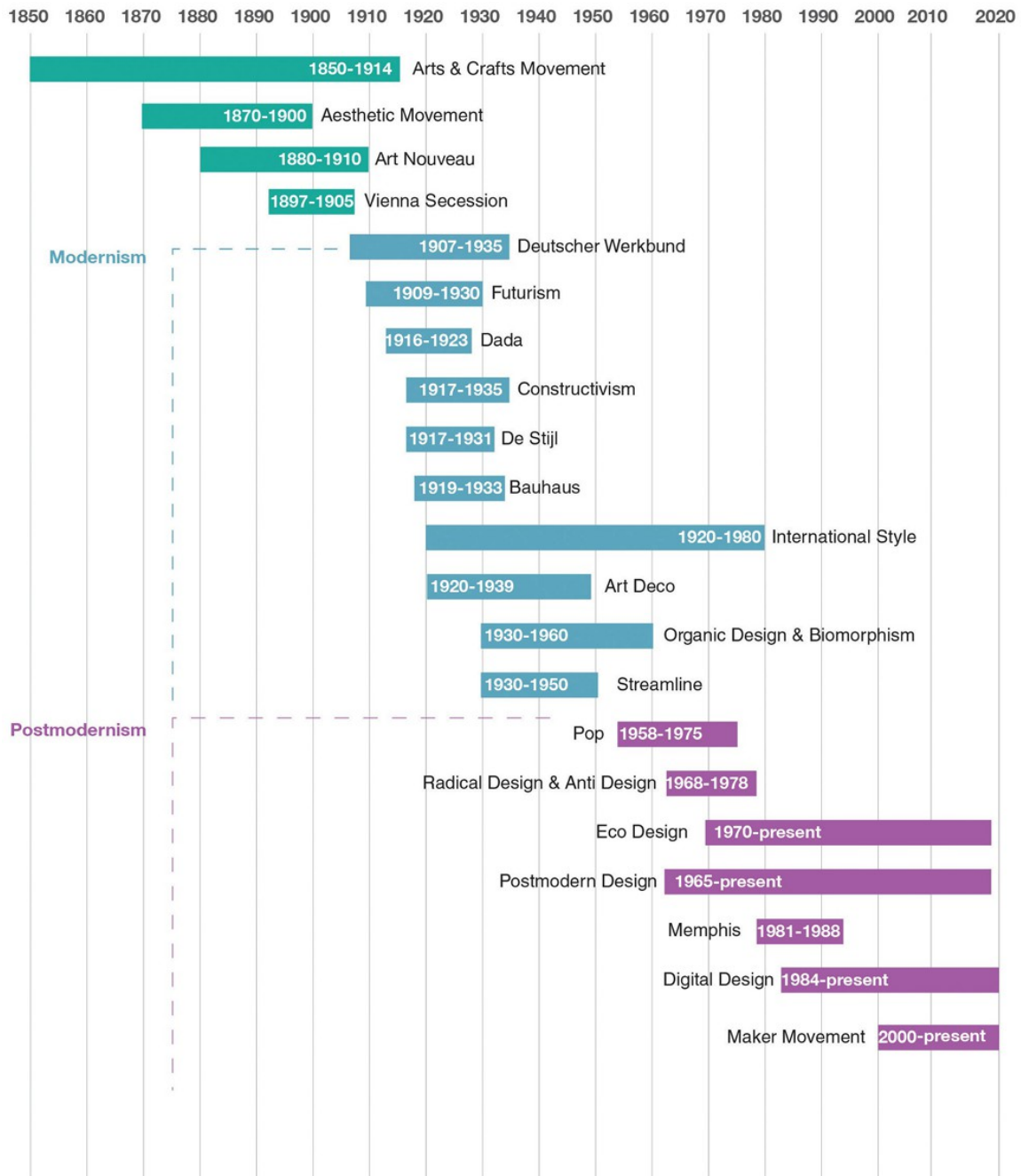



were manufactured. Products once produced locally by artisans were produced en masse and distributed widely. Interestingly, many design styles evolved in direct **reaction** to the social and cultural changes imposed by the Industrial Revolution; some designers reacted negatively while others embraced the new processes.

## Arts and Crafts Movement 1850–1914

The **Arts and Crafts** Movement was influential in British decorative arts, architecture and landscape design. The movement was inspired by the writings of John Ruskin, and a reaction to both the mechanisation of the Industrial Revolution and the over-intricate styling of the Victorian era. The movement called for simplicity and clear function, and believed that beautiful decorative products played a role in the improvement of people's lives. The movement eschewed mass-production techniques in favour of a handcrafted and artisan-based approach. Designers of the Arts and Crafts Movement looked to the natural environment for inspiration and their work often used visual motifs directly sourced from flora. Handmade and carefully crafted, the work was often manufactured using slow, traditional techniques, which meant pieces were generally rare and expensive.

'Anemone' design (textile), Morris, William (1834–96)/Private Collection/  
Bridgeman Images



▲ Morris wallpaper from the Victoria and Albert Museum collection

In Australia, some furniture makers embraced the Arts and Crafts style; Christobel Francis Rojo in

Melbourne and Beard Watson Ltd in Sydney were highly regarded for their Arts and Crafts styling using distinctively Australian timbers. Some houses were built in this style and a few can still be seen in Canberra, Sydney and Melbourne.

### Key designers

William Morris, Charles Rennie Mackintosh, Margaret MacDonald-Mackintosh, Frank Lloyd Wright, Alexander Knox.



High backed chair, c.1897 (dark stained oak with rush seat & pierced oval back rails) (b/w photo), Mackintosh, Charles Rennie (1868–1928)/Private collection/Bridgeman Images

▲ 'Argyle' chair by Charles Rennie Mackintosh, c. 1897

## Aesthetic Movement 1870–1900

Inspired by Japanese woodcuts and Eastern goods and furnishings, the Aesthetic Movement was concerned with the representation of the natural and the beautiful in an Anglo-Oriental style. The movement's emphasis was on interiors and objects that could improve quality of life through their sheer beauty. As in Art Nouveau, a focus on the stylised abstraction of natural imagery was embraced. Writers, artists and designers took up the Aesthetic Movement's doctrine of 'art for art's sake' as defined by playwright Oscar Wilde.

### Key designers

Liberty (Arthur Liberty), Aubrey Beardsley, Arthur Silver

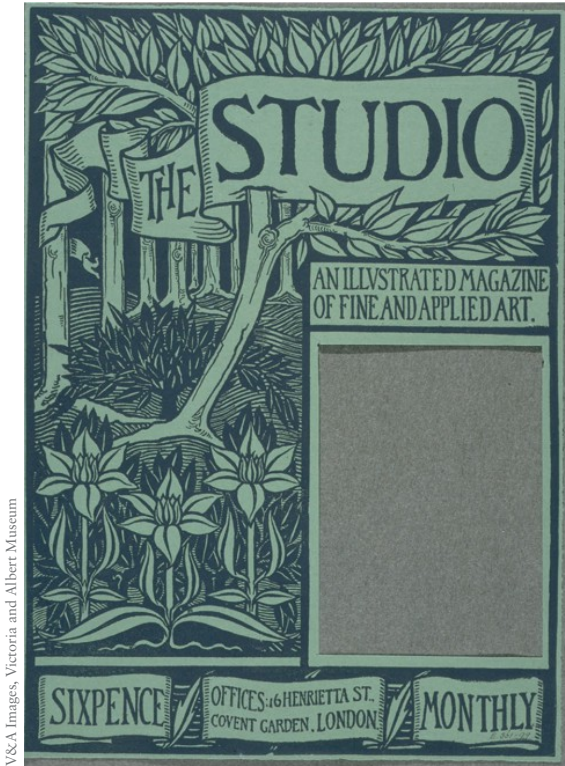

V&A Images, Victoria and Albert Museum

▲ Publication illustrated by Aubrey Beardsley, 1893

### Art Nouveau 1880–1910

**Art Nouveau** was a global movement but was most commonly known by its French identity. It displayed an emphasis on decoration and artistic unity based on natural, organic, flowing shapes and forms. Like movements in Britain, this was a reaction to the urban



▲ Detail of Art Nouveau glass wall, Museum of Modern Art, Brussels

ISBN 9780170401784

environment fostered by the Industrial Revolution. Art Nouveau is distinguished by its **organic** curvilinear forms and sensual and rhythmic styling. The influence of Art Nouveau can be seen in the product design, architecture, jewellery, signage, interior design and graphic design of the period.

In Germany, Jugendstil was an Art Nouveau movement focused on Germanic themes and mythology. The driving force of the Jugendstil movement was the magazine *Munchner Jugend*, which made extensive use of the illustrations and designs of German Art Nouveau artists. In Australia, the influence of Art Nouveau was seen mostly in architecture. In Melbourne, buildings such as the Melbourne Sports Depot in Elizabeth Street, and the City Baths exemplify the style.



Alamy Stock Photo/Dieder ZYLIBERY NG

▲ Art Nouveau entrance to the Paris Metro designed by Hector Guimard in 1900

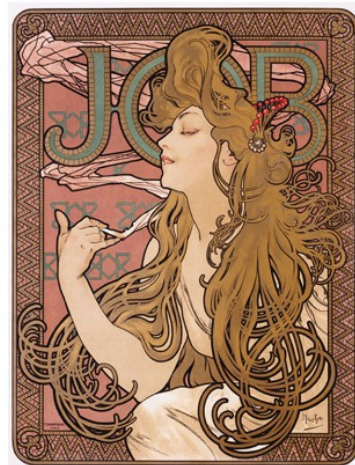

Gerty Images/Swin Ink 2, LLC/Corbis

▲ 'Job' poster by Alphonse Mucha

Nelson Visual Communication Design VCE Units 1–4

### Key designers

Jules Cheret, Henri Toulouse-Lautrec, Leonetto Capiello, Victor Horta, Hector Guimard

### Vienna Secession 1897–1905



▲ Print by Koloman Moser

Formed by artist Gustav Klimt in 1897, the Vienna Secession (meaning withdrawal) was a reaction to the conservatism of the established artistic community in Austria at that time. With the assistance of the City of Vienna and a number of wealthy patrons, the secessionists constructed an exhibition hall in which to exhibit their work, including metalwork, furniture, lithographs and paintings. The hall, designed by Josef Olbrich, with its distinctive geometric features including a gold dome and elaborate decorative elements, was a good example of Viennese Art Nouveau architecture.

The exhibition hall became the focus of the movement and many large-scale exhibitions were held featuring avant-garde artists and designers from across Europe. The secessionists, though together for only a brief time, were highly influential and innovators in the area of graphic design. Their journal *Ver Sacrum* fused typography, ornamental decoration and images with influences from the Far East including Japan.

### Key designers

Gustav Klimt, Josef Olbrich, Josef Hoffmann, Koloman Moser



▲ Vienna Secession poster

### Deutscher Werkbund 1907–35

Established in Germany in 1907, the Deutscher Werkbund is considered by many historians as the foundation of **modernism**. Members of the Deutscher Werkbund recognised that a formal visual language of function was



▲ Poster for 'Deutsche Werkbund-Ausstellung' by Peter Behrens, 1914

overtaking the decorative and expressive design of the Jugendstil. In the chaos that followed the First World War, the group recognised the need for standardisation in the production of objects, and produced simple forms that featured plain rather than decorative surfaces.

### Key designers

Peter Behrens, Julius Klinger, Walter Gropius, Ludwig Mies van der Rohe

## MODERNISM

FYI

Modernism is a design aesthetic that developed in the early part of the 20th century and continued into its later stages. Modernism reflected the zeitgeist, or 'spirit of its age'. Rising from the bleakness of wars, modernism was optimistically underpinned by utopian social ideals. Modernists rejected the decorative motifs of the 19th and early 20th centuries in favour of clean, functional forms. Surface decoration was minimally used and, when it was applied, appeared restrained. Visually, modernism was characterised by the use of modern materials (such as steel and glass), the application of abstract forms, the manipulation of space and a conservative colour palette, dominated by whites, greys and black. Modernism is often summarised by the expression 'less is more', coined by Bauhaus member Ludwig Mies van der Rohe.

## Futurism 1909–30

Established by Italian writer Filippo Tommaso Marinetti, and inspired by Cubism, Futurism was one of the first truly radical design movements. Concerned with embracing technological progress, the Futurists were highly influential to subsequent movements. The written word and the printed word were central to the philosophy of Futurism and designs often involved bold, complex combinations of fragmented typography, repeated icons and

Roman numerals. In London, the visual characteristics of Futurism were adopted by the Vorticists. During the 1920s many of the stylistic elements of Futurism, such as strong grid structures, were incorporated into print advertising, book design and magazine layouts.

### Key designers

Giacomo Balla, Umberto and Carlo Carra, Edward McKnight Kauffer



Tullio D'Albisola/SCALA, Florence

▲ Front cover from *Parole in Libertà Futuriste: Tattili-Termiche Olfattive* by Tullio D'Albisola, 1924

## Dada 1916–23

Established in reaction to the atrocities of the First World War, this artistic and literary movement used

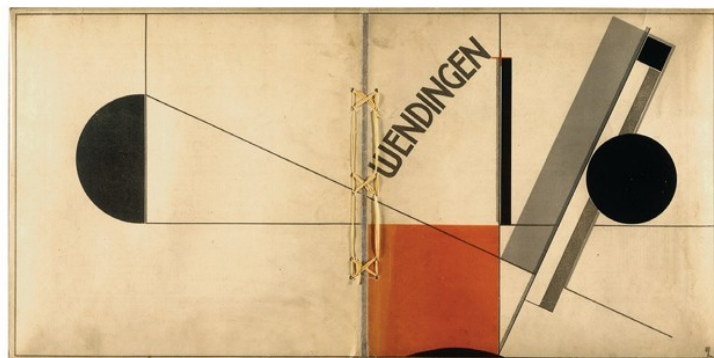

▲ *Wendingen* journal cover by El Lissitzky

experimental techniques, collage and randomly generated words and images to create theatre, poetry and artworks. Although **Dada** is not usually seen as a design movement, the Dadaists exerted a major influence on modern graphic design. Their unconventional compositional strategies and anarchic approach to visual ‘order’ continued to inspire many designers in the later part of the 20th century.

### Key members of Dada

Tristan Tzara, Man Ray, Francis Picabia, Kurt Schwitters, Hannah Hoch, Richard Huelsenbeck



▲ *Da-Dandy*, 1919 (collage) by Hannah Hoch

### Constructivism 1917–35

Constructivism refers to a primarily Russian movement that occurred after the revolution of 1917. Constructivist designers developed an approach to design that was strongly linked to the industrial production of well-designed utilitarian objects

accessible to the masses. The Constructivists strove to reflect the principles of Communism in their work and eschewed the purely decorative for the primarily functional. They rejected the value of fine art, as they believed that utilitarianism was superior. In their print work, the constructivists used geometric shapes and bold colours to represent industrial products. Colour symbolism was important, with the revolutionary colours of red and black forming the main colour palette. Typography was used extensively as was photography. Constructivist posters by El Lissitzky often showed highly experimental techniques including photograms and photomontage, reflecting the Constructivist theme of ‘artist as engineer’.

### Key designers

Vladimir Tatlin, El Lissitzky, Valentina Kulagina, Kazimir Malevich

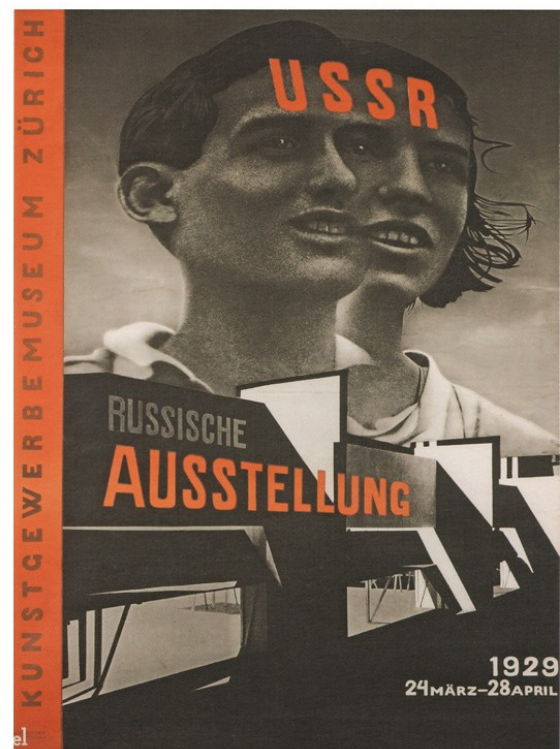

▲ Poster by Eleazar (El) Lissitzky for the Russian Exhibition in Zurich, 1929

## De Stijl 1917–31

De Stijl or ‘The Style’ was a movement established by a small group of Dutch artists, architects and designers in 1917. De Stijl designs were characterised by the use of strong, simple geometric forms and blocks of solid colour that defined space. Decorative excess was rejected in favour of dramatic simplification. De Stijl designs had an immediate impact on graphic design in the period after the First World War, and their designs for typefaces, posters and journals were embraced by the European avant-garde.

De Stijl design principles continued to be influential in the later part of the 20th century. Theo van Doesburg’s letterforms and Gerrit Rietveld’s famous Red-blue chair symbolise the style of the movement.



▲ Gerrit RIETVELD (designer) the Netherlands 1888–1964, G. A. VAN DE GROENEGAN, DE BILT (manufacturer) the Netherlands 1924–1971, Red-blue chair (1917) (designed), (c. 1970) (manufactured) painted beech and plywood, steel 86.5 × 66.0 × 83.0 cm, National Gallery of Victoria, Melbourne. Purchased, 1970 (D33–1970)

### Key designers

Theo van Doesburg, Gerrit Rietveld, Bart van der Leek, Piet Mondrian

ISBN 9780170401784

## Bauhaus 1919–33

Formed in 1919, the Bauhaus, meaning ‘building house’, was a significant German design school established first in Weimar and then Dessau. The Bauhaus director, Walter Gropius, believed that the making of objects and constructions was an important social and intellectual pursuit, and he encouraged students to follow a functional aesthetic. Initially, members of other design movements became part of the Bauhaus including Theo van Doesburg, Laszlo Moholy-Nagy and El Lissitzky. Artists such as Paul Klee and Wassily Kandinsky also found positions within the school’s varied faculties.

All brought influences from across Europe and many aspects of the early Bauhaus were directly linked to the principles of Constructivism. Core studies at the Bauhaus focused on the logical analysis of form and function. The use of materials such as steel, plexiglass, rayon and even cellophane in design were radical departures from traditional visual arts training. Students were taught to use instruments in their drawings; items such as the compass and the straightedge ruler, which had previously been the tools of engineers and draftsmen, became part of the creative process within the Bauhaus.



courtesy of Knoll, Inc. Photography by Joshua McHugh for Knoll, Inc.

▲ ‘Barcelona Chair’ by Ludwig Mies van der Rohe, 1929

Bauhaus designs did not like decorative motifs, creating designs that featured an industrial ‘machine aesthetic’. Studies at the Bauhaus included graphic design, typography, furniture design, architecture, textiles and metal. A significant focus of designers within the Bauhaus was the combination of photography and typography.

Nelson Visual Communication Design VCE Units 1–4

The design of geometric letterforms and the use of lower-case type in publication design were progressive and influential. Eventually, the radical designs of the Bauhaus were seen as subversive by the Nazis and the school closed, with key teachers or 'masters' moving to the United States, where they inspired the rise of the International Style.



© 2012. Digital image, The Museum of Modern Art, New York/Scala, Florence

- ▲ Brandt Marianne (1893–1983): Kandem Bedside Table Lamp, 1931. New York, Museum of Modern Art (MoMA). Lacquered steel h. 9 1/4' (23.5 cm), base w. 7 1/4' (18.4 cm) Phyllis B. Lambert Fund. Acc.n.: 191.1958

### Key designers

Walter Gropius, Ludwig Mies van der Rohe, Marcel Breuer, Marianne Brandt, Gunta Stölzl, Laszlo Moholy-Nagy

## The International Style 1920–80

The term International Style was established following an exhibition called 'International Style: Architecture Since 1922' held at New York's Museum of Modern Art in 1931. The exhibition featured modernists such as Le Corbusier, Walter Gropius and Mies van der Rohe. The term refers to a global movement of architects and designers whose application of function and pared-down geometric forms reflected aspects of the Bauhaus aesthetic. This period is most identified with modernism and reflected the shift of design influence from Europe to the United States.

During this time there was a significant shift in visual **culture**; the work of Saul Bass and Paul Rand saw graphic design come into its own as a recognised and esteemed design discipline. From the 1950s onwards,



© Foundation Le Corbusier, Charlotte Perriand and Pierre Jeanneret/ADAGP. Licensed by Viscopy, 2017

- ▲ Le Corbusier (designer) France 1887–1965, Charlotte Perriand (designer) France 1903–99. Cassina, Milan (manufacturer) Italy est. 1927, LC/4 chaise longue (1928) (designed), (c. 1970) (manufactured) horse skin, leather, chromium plated steel, painted steel, rubber, cotton, metal, Dacron (a-b) 70.9 × 160.5 × 57.3 cm (overall), National Gallery of Victoria, Melbourne. Purchased, 1971 (D194.a-b-1971)



© The Estate of Athol Shmith, Licensed by Kalli Rolfe Contemporary Art

- ▲ 'This elegant photograph, taken in 1949, shows the clean lines of a Christian Dior dress to wonderful effect. A reference to internationalism is neatly suggested by Shmith who shows the model holding an illustration of another model in a baroque French interior. However, unlike the lushness of the illustration, Shmith's photograph has a pared down quality that draws the viewer's attention to the distinctively lean shape of the dress.' National Gallery of Victoria

Athol Shmith, Australian 1914–90, No title (Fashion illustration. Model Patricia Tuckwell) 1949, gelatin silver photograph 310.8 × 28.8 cm, National Gallery of Victoria, Melbourne. Purchased through The Art Foundation of Victoria with the assistance of The Ian Potter Foundation, Governor, 1989)

advertising agencies appeared in great numbers, driving the need for print-based design. The importance of logos and branding was recognised during this period; in Europe the rise of the ‘Swiss’ style was exemplified by developments in typography. In fashion, this period was personified by Christian Dior’s ‘New Look’.

In Australia, the International Style was reflected in architecture and product design. Roy de Maistre’s furniture and the works of Harry Seidler and Robyn Boyd indicate the style aesthetics. The former ICI building in East Melbourne (now Orica House) is a heritage-listed example.

### Key designers

Ludwig Mies van der Rohe, Le Corbusier and Charlotte Perriand, Philip Johnson, Saul Bass, Hera Roberts, Fred Ward, Florence Knoll

### Art Deco 1920–39

Art Deco refers to a mix of styles that occurred between the World Wars, from 1920 to 1939. The title of the movement came from the ‘Paris Exposition Internationale des Arts Décoratifs et Industriels Modernes’ exposition



▲ Paris exposition poster, 1925

ISBN 9780170401784

of luxury goods and decorative arts in 1925. The visual characteristics of the Art Deco style – symmetry, simplicity and geometry – formed a visual language that was applied across a wide range of products and artworks.

The style was seen as a celebration of glamorous modern lifestyles, and it distilled many visual features of modern art styles such as Cubism and Futurism. Art Deco influenced architecture, interior design, industrial design, jewellery, furniture, ceramics, textile and graphic design. It was an enduring style that spanned almost two decades and took inspiration from an increasingly global society. As an impressively eclectic design movement, Art Deco drew influences from many sources; however, it was the exoticism of Egypt, the Orient and Africa that gave the style many of its distinctive characteristics. The works of architect Walter Burley Griffin and graphic artist Percy Trompf typify the Australian Art Deco style.



Alamy Stock Photo/James Jenkins - Visual Arts

▲ Art Deco tea set by Clarice Cliff



▲ Typical Australian Art Deco architecture featured rounded corners and linear details. Colours were muted and surfaces rendered or painted.

Nelson Visual Communication Design VCE Units 1–4



### Key designers

Cassandre, William Van Alen, Jean Carlu, Pierre Legrain, Mariano Fortuny, Thea Proctor, Clarice Cliff, Marion Mahony Griffin, Walter Burley Griffin, Walter Jardine.

### Streamline 1930–60

Streamline refers to the sleek, rounded and smoothly finished forms that were used during the 1920s and 1930s in the design of ships, trains and aircraft. These streamlined forms – designed to enhance the aerodynamics of transportation – were appropriated in product design and used to make household objects appear sleek, modern and more appealing to the consumer. Particularly common in American product design, streamlining became popular after the stock-market crash of 1929, as consumer spending decreased and markets became more competitive. This period is sometimes referred to as American Moderne.



▲ 'A New Blue Train to the Cote D'Azur', by Pierre Zenobel, 1928



▲ Emerson Patriot Radio, designed by Norman Bel Geddes, mid-20th century

### Key designers

Norman Bel Geddes, Raymond Loewy, Eliel Saarinen, Walter von Nessen, Kem Weber, Gilbert Roohde

### Organic Design and Biomorphism 1930–60

While the International Style was dominated by powerful geometric forms, Organic Design – and, later, Biomorphism – approached design from a holistic perspective, taking into account human factors such as comfort. Frank Lloyd Wright was a pioneer of Organic Design; his architectural and furniture designs were conceived as a whole theme rather than in single parts. It was hoped that designs brought together in a holistic way would reflect nature. In the late 1920s, designers such as Alvar Aalto crafted wood into furniture that moulded to the human form. In the 1940s, husband and wife designers Charles and Ray Eames developed single-form moulded chairs that have had an immense and lasting impact on furniture design. Designers Grant and Mary Featherston pioneered the use of formed wood in Australian furniture design.

### Key designers

Charles and Ray Eames, Eero Saarinen, Frances Burke, Verner Panton, Frank Lloyd Wright, Alvar Aalto



- ▲ Charles Eames (designer) United States 1907–78, Ray Eames (designer) 1916–88, Herman Miller, Michigan (licensee) United States est. 1923, Herman Miller (Aust.) Pty Ltd, Melbourne (manufacturer) Australia est. 1962, Lounge chair 670 and Ottoman 671 (1956) (designed), (1972) (manufactured) leather, plywood, aluminium, nylon, zip, (other materials); (1) 85.2 × 86.2 × 83.3 cm (lounge chair) (2) 42.7 × 65.6 × 54.6 cm (ottoman). Purchased, 1972 (D80.1-2-1972)

## POSTMODERNISM

Postmodernism is a term used to describe the progressive architecture, design, literature, visual communications, music, sociology and film that have evolved since the 1960s. Like modernism, postmodernism is a reflection of the spirit of the age. Early postmodernists reacted against the perceived structural constraints of modernism, which they saw as conservative and restrained. Postmodernism is firmly embedded in contemporary creative and popular culture. Visually, it is characterised by the decoration and ornamentation that was rejected by the modernists, and by experimental approaches. The term is a complex one and therefore quite difficult to define, but architect, designer and writer Robert Venturi wrote 'less is a bore', turning the modernist credo on its head.

FYI

## Pop 1958–72

Pop design set many of the foundations for postmodernism. Just as Pop artists like Andy Warhol looked to popular culture for inspirational material, Pop designers appropriated materials and design elements found in the everyday. Readily discarded objects constructed from disposable materials – such as inflatable furniture – reflected the prosperity of the time. Pop design was aimed at a youth market and was inspired by social change such as the rise of the psychedelic phase, the space race and the growth of consumerism in the 1960s.

Pop design was strong in Britain during the 1960s, and its non-conformism later splintered into the rise of punk in the early 1970s. Direct links to earlier movements such as Art Nouveau and Dada can be seen in many works from this period. The design of magazines such as *Rolling Stone* and *Oz* challenged the formal traditions of the International Style.



Ball Chair, design Eero Aarnio. Photo: Harri Kosonen, Studio Sempire

- ▲ Ball chair, designed by Eero Aarnio

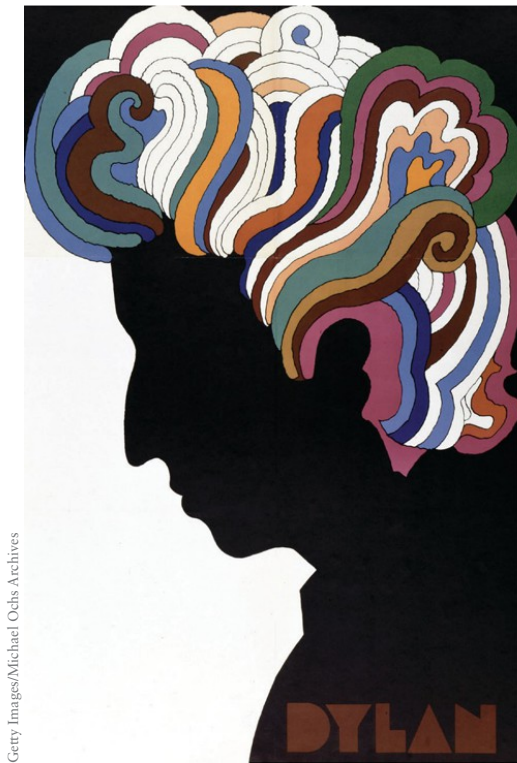

Getty Images/Michael Ochs Archives

▲ Dylan poster by Milton Glaser.

### Key designers

Victor Moscoso, Seymour Chwast, Milton Glaser, Eero Aarnio, Joe Colombo

## Radical Design and Anti-Design 1968–78

Established in Italy in the late 1960s, Radical Design was epitomised by two main studios, Archizoom Associati and Superstudio. The groups wrote manifestos and designed products inspired by the sculptures of Claes Oldenburg. The Radical Design Movement is often seen as the direct precursor to postmodern design, as it sought to blur the traditional visual language of modernism and push the bounds of socially defined 'good taste'. The distortion of proportions, clashing colours and the juxtaposition of materials were common in Anti-Design. Anti-Design was ideologically similar to Radical Design.

### Key designers

Ettore Sottsass, Alberto Colombi, Ezio Didone, Jonathan De Pas, Donato D'Urbino, Paolo Lomazzi



Alamy Stock Photo/INTERFOTO

▲ Sottsass, Ettore (1917–2007): Summa 19 Calculator, 1970. New York, Museum of Modern Art (MoMA). Plastic, 4 × 8 × 14" (10.2 × 20.3 × 35.6 cm). Manufactured by Ing. C. Olivetti & C. S.p.A., Ivrea, Italy. Gift of Jo Carole and Ronald S. Lauder. Acc. n.: 65.2007.

## Eco Design 1970–present

After the energy crisis of the early 1970s, Victor Papanek published a book called *Design for the Real World*, which outlined the responsibility of the design community in developing and using sustainable materials and reducing environmental impacts through design. In the 1980s, environmental concerns gained public momentum and companies began to use 'green awareness' to distinguish their products within the marketplace. During the 1990s, raised awareness of greenhouse gas emissions and deforestation meant that consumers began to demand alternative and recyclable materials. This movement is also known as Green Design or DfE (Design for the Environment). Sustainable design is an ongoing challenge for designers in all disciplines.

## Postmodern Design 1965–present

As we have seen, postmodernism refers to the stylistic developments that depart from the norms of modernism. Postmodern designers questioned the modernists' emphasis on logic, simplicity and order, suggesting that ambiguity and contradiction may also have a valid place. Postmodernists introduced colour, ornament, references to historical styles, and elements

that sometimes appeared eccentric or disturbing. They sought to make reference to past design movements in order to re-establish an emotional connection between the designer and the user – a connection that they believed had been lost in the abstraction of the modernists. Magazines such as *The Face* and *Emigre* pushed the boundaries of typographic and structural style. Postmodernism is stylistically diverse and ever-changing. The product designs of the Alessi Company in Italy are recognised as postmodern design, as is the work of Australian designer Marc Newson.

### Key designers

Frank O. Gehry, Philippe Starck, April Greiman, Michael Graves, Richard Eckersley, Tibor Kalman



Philippe Starck for Alessi/Powerhouse Museum, Photo: Nitsa Yioupros

▲ An icon of postmodern design, the 'Juicy Salif' was designed by Philippe Starck for Alessi in 1990.

### Memphis 1981–88

Memphis was a reaction to the formal lines and forms of the International Style. Formed by Ettore Sottsass in 1981 and based in Milan, the Memphis group drew inspiration from Art Deco, Pop art and

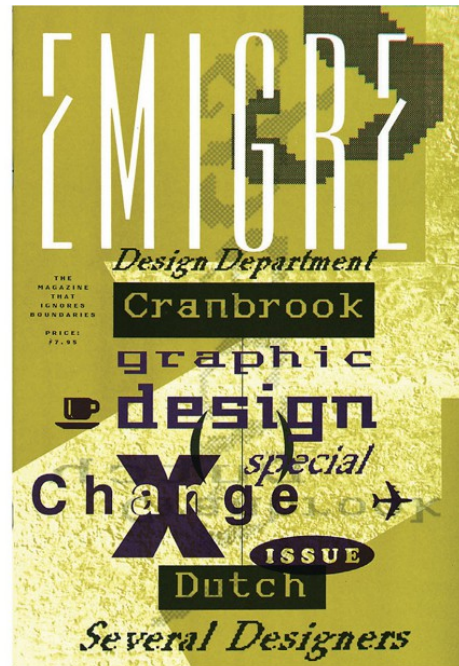

Emigre Magazine

▲ *Emigre* magazine was published from 1984–2005 and was a leading graphic design magazine. It was one of the first publications to use computers for layout and used many different typefaces and layout styles in each issue.



Ettore Sottsass for Memphis/Powerhouse Museum, Photo: Andrew Frolows

▲ Memphis 'Carlton' room divider by Ettore Sottsass

kitsch. Memphis challenged the aesthetic concerns of the modernist styles, blurring the boundaries of design through the incorporation of highly decorative forms, bold colours and pattern. Memphis looked to popular culture, mass-produced objects and the rise of computer games and science fiction, and worked across a wide range of media and products.

### Members of the Memphis Group

Ettore Sottsass, Martine Bedin, Aldo Cibic, Michele De Lucchi, Matteo Thun, Marco Zanini

### Digital Design 1984–present

The rise of digital technology has had an enormous impact on the nature of design and visual communication. Computer-based technologies have transformed the traditional design space, and designers are required to respond. The versatility of the computer to research, model, test, form and enhance design has had an effect on the nature of the designer. Easy access to digital tools means that individuals with little or no training can ‘design’ content for print or electronic format. Some postmodernists see the



▲ Hand-drawn and digital image by Deanne Cheuk

computer as an equaliser, moving the realm of design from specialists to anyone with interest and access. The diversity of digital media has blurred the definitions of artist, designer, filmmaker, musician and animator.

### Significant contemporary designers

Michael Place, Vince Frost, Marc Newson, Deanne Cheuk, Rinzen, Joshua Davis, Zaha Hadid, Tord Boontje, Karim Rashid



Karim Rashid Inc.

▲ Kettle by Karim Rashid

### The Maker Movement 2000–present

Seen as a response to the dominance of digital products, the Maker Movement evolved from growing interest in traditional methods of making and production, combined with new technologies. The movement embraces social media and fosters a sharing culture using Instagram and Pinterest to observe, collect and encourage artisanal production. As technologies have developed, so have the collaborative possibilities of Maker culture. Some Maker Spaces provide digital fabrication technologies while others focus on traditional hand skills. Maker Spaces, which became more prominent in the mid-2010s, appeared as shared workshops and ‘labs’ at schools, universities

and in the public and private sectors. Creativity was recognised as an essential tool in learning, professional development and in a wider community context.

Over a relatively short period of time, Maker culture expanded into areas not previously considered part of the design movement such as food and personal care. Artisanal products such as coffee roasting, beer brewing and traditions such as barbershops appeared using a dynamic social media presence and tools such as app-based bookings and order systems.

At its core, Maker culture strives for a balance between recognising the origins of products while embracing ever-new technologies to build, promote and create products, services and designs. In many areas, it is possible to see the 'hand' of the artist evident in Maker products from hand-drawn lettering to handmade clothing. Promoting many aspects of the movement was a parallel expansion of market culture, including many art markets, farmers' markets and makers' events in urban and regional areas.



Makerspaces&company

- ▲ Spaces such as Maker Space in Sydney provide industrial-grade machinery for woodwork, metalwork, ceramics, textiles and electronics, partly in response to the need for equipment that requires hands-on interaction, rather than making through the interface of a screen.



Commonfolk Coffee Company Pty Ltd

▲ Commonfolk in Mornington is an example of a creative, multi-use maker space. Small, artist-run studios operate in the same space as an artisanal coffee roaster and cafe. The coffee is ethically sourced and the space allows for creative processes to be viewed from many angles.



Sarah Dingwall, photographer: Salona

▲ Glass artist Sarah Dingwall, one of the founders of Commonfolk, in her glass studio adjacent to the cafe and roaster. Visitors can watch Sarah at work and purchase her designs directly from her studio space.

## IDENTIFYING HISTORICAL CONNECTIONS

The history of design is not linear – it interweaves and overlaps, infiltrates and inspires. As time and movements pass, new designers take the legacy of their predecessors and either develop it further or react against it. Each stage of design history is connected to the next and to those beyond.

In the 1990s, an increased interest in **minimalism** and the aesthetic of the modernists arose amidst existing postmodern designs. Product designers, architects, textile designers and fashion designers made reference to the Bauhaus and International Style in their new work. Such influence is not always direct or obvious, and the stark minimalism of the mid-1990s was not a direct copy of its modernist forbears, but a nod to their original aesthetic. It is interesting to note that postmodern characteristics can live in relative harmony with modernist considerations in the 21st century.

Identifying the links and influences between design styles and movements is not always straightforward and can involve having to sort through the popular combinations of historical and contemporary styles. However, there are some steps that can be taken to make the task of seeking and recognising links easier.

### Familiarise yourself with key design movements

Using the timeline at the beginning of this chapter as a guide, investigate some significant examples of each design style. Each style is identified by characteristics such as the application of design elements and principles and the use of materials. In architectural design, for example, the application of steel, glass and rendered white surfaces in the construction of simple geometric structures could be linked to the designs of Richard Neutra and the International Style.

### Don't assume that contemporary design is 'new' design!

Many designers make reference to other designers deliberately. Such references might be designed to appeal to a specific audience that is aware of the other designer's work, or to give the design historical

significance through a linked relationship. There are few truly original ideas, and many creative and striking designs are a hybrid of the designer's creativity and the influence of a mentor, inspirational figure or movement.



© Jamie Reid courtesy John Marchant Gallery

▲ The cut-and-paste collages by Jamie Reid (a friend of the Sex Pistols' manager, Malcolm McLaren) became an intrinsic part of the Sex Pistols' visual identity. It is possible to see influences from Kurt Schwitters and the Dada artists in his work.

### Read design magazines

Design magazines provide a wealth of information about professionals working in contemporary design. Journalists who have specialist experience in design are often aware of the influences and similarities between designers, design studios and even the design produced by different countries. Many articles and journals can also be found on the Internet.

### Look at the wider context

When looking at the work of designers at any stage in history, it is valuable to investigate other professionals, such as artists, musicians, writers and academics, who were active at the same time. Many designers form networks and groups with those who share the same values and interests, and develop their ideas and design philosophies together. Understanding a design group or movement is important when understanding the wider context of design.

### The social context

The social, economic and political environment has a significant impact on the establishment and evolution of design movements. Economic and financial factors



can also influence the growth and development of design. Given the fundamentally commercial nature of design, the economic climate may dictate the success and longevity of design products.

## ECONOMIC AND POLITICAL FACTORS IN DESIGN

### ECONOMIC INFLUENCES

From the end of the 19th and into the 20th century, the impact of the previous 200 years of industrial development in the Western world was clearly visible. Cities had expanded to accommodate workers in the manufacturing sectors. Fewer people lived on the land in rural areas and the domestic lives of most people had undergone significant change. Access to electricity, clean water and secure housing meant a higher demand for home comforts. Decoration of the domestic space became the province of many rather than of the privileged few. This, in hand with access to a greater choice of products, built a consumer culture on a scale that had not been seen before.

The period between the world wars in Europe was a time of great social turmoil and change. In Germany, defeat in the First World War led to considerable social disarray, as industries were damaged and the economy was ruined. From these circumstances rose the Bauhaus, arguably the most influential design movement of the 20th century. In accepting the need for industrial growth, designers developed the functionalist approach to design, a manifesto that eschewed the decorative embellishment of prewar crafts in favour of simple unadorned designs.

Design does not evolve in a vacuum; it is affected by the circumstances of the society in which it exists and serves. Periods of economic decline affect the industrial and manufacturing sectors, which in turn can have an impact on the employment and social conditions of workers. During the Great Depression of the 1930s, many businesses closed and consumers had little money to spend. At a time when money was scarce and competition between companies was fierce,

some appliance manufacturers adopted the streamlined designs of the period in order to attract an audience to new products.

During wartime, governments often restrict the manufacture of non-essential items and take over existing factories for military production. During the Second World War, many materials were in short supply and designers were employed on government projects to develop designs that used alternative materials. After the war ended, many of the processes established during wartime were applied to domestic products.

New materials such as bakelite, a precursor of plastic, gave rise to product design that could be freely styled and formed repeatedly. The cost of appliances tumbled during the postwar boom, which fed the further development of new processes and materials.



National Library of Australia, 'For freedom, have you bought a war loan bond?', John Sands, Sydney, 1915–18

- ▲ During wartime, posters were used for propaganda, to encourage enlistment and to garner financial support through the purchase of war bonds. In this Australian poster c. 1915, it is possible to see the influence of Art Nouveau in the imagery used.

The rapid development of materials continued in the second half of the 20th century with lower costs of production and increasing demand for goods. Plastics and synthetic materials and the automation of manufacturing production made many objects less expensive and more accessible to the consumer. In recent times, the rise of manufacturing powerhouses such as China have meant that designed products including both three-dimensional and print products are manufactured in large quantities at a smaller financial cost than ever before. Booming economies, increased disposable incomes and consumer desire for new products drive the demand for accelerated design and manufacturing. The accessibility of such quantities of cheaper products in the 21st century has had its own impact on consumer waste and the environment. In the retail sector, the sheer variety of available products for consumers to choose from is far greater than designers of the early 20th century could have imagined.

## POLITICAL CHANGE

Political upheaval has an impact on many aspects of a culture, including design. Some governments actively support design innovation through financial assistance and the establishment of schools. Conversely, governments that perceive subversion through creative expression and innovation in design often oppress and persecute those involved in the field, leading to an exodus of talented designers. This can have a positive impact on other countries, which may benefit from the exile of creative professionals. The Bauhaus was disbanded during the rise of Nazism in Germany, leading to Bauhaus ideas spreading throughout the United States and internationally.

Political change is often a trigger for design. Governments often commission political posters, visual propaganda and architectural displays of power or prestige. In Italy and the Soviet Union, design movements such as Futurism and Constructivism evolved with the support of the respective governments, and although these relationships may not have endured, the visual communications produced had a significant impact on the progress of design. During times of war, posters that promote the cause and those that protest the war use powerful visual communications to send a political message.



National Library of Australia, 'May Day, 1942', Labor Council of New South Wales, 1942. [nla.obj-135796629]

- ▲ In this political poster from 1942 it is possible to see the influence of Constructivist design.



Gerry Images/Robert Daemrich Photography Inc/Corbis

- ▲ Political promotion and advertising can be powerful. Iconic images, such as this famous image of Barack Obama from the 2008 US presidential election have influence far beyond their original audience and purpose. The image, designed by Shepard Fairey, has been appropriated and reused in other cultures and contexts for a range of reasons.

## THE SOCIAL CONTEXT OF DESIGN

Societies operate in a constant state of change. Social structures, values and relationships are affected by many variable factors that have an impact both at a personal level and at a wider community or global level.

Visual communications are often a reflection and extension of the society they were created within. Design can push the boundaries of the social fabric – and often does so. Design can reflect and represent commonly held social values on the one hand, while challenging and questioning those values on the other hand. Advertising, architecture, packaging and fashion constantly challenge the norm. Imagery and content that is perceived to be unacceptable in one context is embraced in another.

Design can also direct social change. Trends are highly influential in many social groups. Fashions and trends – established by designers through magazines and the wider media – affect what we buy and when we buy it. The lifestyle associations of the products themselves can dictate what we purchase, wear, drive or use. Presenting images that are alluring and desirable, visual communications can direct consumer choice and preference.

The effect of design at the social level is often determined by culture. What is acceptable advertising in one country may be offensive and even illegal in another. Religious values and cultural taboos can determine the appearance and content of visual communications. Appropriateness in content changes over time, and in contemporary Western society the use of controversial images, in particular those that display nudity or confronting behaviours, has become prevalent.

Visual communications are sometimes used as a form of social protest. Street art is commonly used to express opinions about social and political events or injustices. Graffiti, particularly stencil art, is also seen as a form of creative expression for young artists who wish to make a strong political or social statement.

The ‘Occupy’ protest movement uses graphic means to emphasise their cause. In 2011 protestors across the globe were invited to use tools and images available



▲ Screen-printed poster produced for West R.A.I.D. (Western Region Accommodation for people with an Intellectual Disability) and the Western Suburbs Legal Service.

online to create posters and infographics, along with film and video, to add visual content to the protest movement. In the past, a protestor may have attended a rally with a placard; access to social media provides many more mediums for getting the message across.

### LINK: ADBUSTERS

Adbusters is a pro-environment, anti-consumerist, activist group. The group is renowned for its use of confronting, subversive and emotive design in posters, graphics and memes. It encourages like-minded people to create their own design work with a message. You can link directly to the Adbusters website via <http://vcd.nelsonnet.com.au>.

Social media has had an impact on the prevalence of design in contemporary life. Trends and changes in design are accessed far more readily than ever before. With design blogs, image and link sharing, there is an immediate awareness of new designs. Technology not only enables us to see design products quickly; the expansion of online retail means that we can purchase these products without even holding them first. Partially in response to this, the early years of the 21st century have seen an increased interest in the ‘handmade’ and

the development of a craft-influenced design aesthetic. Traditional techniques such as letterpress, screenprinting, hand-drawn typography and craft arts appear in galleries and feature in online design blogs. A combination of old and new techniques, of contemporary design principles and artisanal craft has led to the growth of what is known as 'new craft' or the 'maker's movement'.

## CULTURE, RELIGION AND DESIGN

Religious and cultural beliefs can impact on the design of visual communications. For a long time, religious groups were at the centre of the cultural and artistic life of communities. In the West the Catholic Church was often the patron of artists and architects, particularly during the Middle Ages and the Renaissance.

Religious buildings have tended to reflect the trends in architectural design at the time they were built. In the recent past, places of worship have been built with modernist and contemporary design aesthetics.

The function of a church is very different to other communal and commercial buildings, so the needs of the clients/users are important for a designer to address. The designer needs a clear understanding of the religious and cultural significance of their design decisions. The position of a building on its site or the choice of colours for the interior can have great significance to the client.

Likewise, in visual communication design, the context and audience of the visual communication will often determine the appropriateness of religious and culturally sensitive imagery. However, recent controversies over illustrations showing religious icons and deities demonstrate that in the age of global media, what is merely provocative in one culture may be seen as highly offensive in another. For designers, sensitivity to cultural factors is an important trait to develop. It may be as simple as the selection of colour – understanding the symbolism of colours in different cultures – or the use of religious and cultural symbols and icons.

## TECHNOLOGY AND DESIGN

Advances in manufacturing processes, materials and design technology have a direct impact on the nature of design. The development of technology affects every aspect of a design, from the initial design stages to final production.

In the 1880s, typesetting was mechanised for the first time and the production of print-based products such as posters, books and magazines became more efficient. Hand-set lettering vanished quickly and the relative ease of new type technologies added impetus to the rise of graphic design and advertising.

In the late 1940s and the 1950s, considerable advances were made in materials technology, as the technologies developed during wartime were applied to a domestic context. Lightweight, flexible and durable materials such as plastics could be manufactured readily and cheaply, providing scope for the refinement of many products. Domestic appliances made of lightweight materials became more portable, cheaper to purchase and easier to use.

Many industries use innovation and advances in technology to increase output and productivity. Production systems such as vacuum moulding and injection moulding have revolutionised the design of products, from small appliances to automotive parts. Advances in electronics have replaced cumbersome methods



Shutterstock.com/Robert HM Voors

▲ The chapel, Notre Dame du Haut (also known as Ronchamp) by Le Corbusier, designed in 1954.

of production. Fibre optics, integrated circuits and silicon chips have allowed products to be scaled to the smallest workable size.

As a result of the application of digital technology, design development that once may have taken weeks by hand, may now take only hours or less. The use of computer-aided design means that visual communications can be devised, designed and produced on the one source.

Constant developments in technology – from ‘smart’ fabrics and papers that ‘read’ and convey information to smaller processors and enhanced interactivity – affect all aspects of design. Developments in technology ultimately affect how visual communications are created, as consumers demand the new and the innovative.

Advances in technology can define design disciplines; for example, motion graphics, animation and Web design are all design specialities that have grown from developments in available technologies. Increasing awareness of how we use technology has led to the establishment of professionals who specialise in ‘user-centred design’ and focus on designing effective user interfaces and digital experiences. Design disciplines that were unknown or non-existent only a few years ago may rise to high importance as technologies advance.

Challenges for designers in this rapidly evolving technical environment are vast. Designers whose work is in the public domain sometimes struggle to maintain control over their work across the global context of the Web. The rise of ‘citizen designer’ (a term used to describe people who are untrained users of design software) means that anyone with access to a computer or mobile device and the Internet can design and post graphic products quickly and independently. Social media means that the spread of good (and bad) design is rapid and powerful.

## DESIGN AND THE ENVIRONMENT

The environmental impact of design is an issue that has been actively addressed in the past 30–40 years. Ecological degradation due to manufacturing is a consequence of high demand for products, housing and electronic goods. Since the Western industrial revolution of the 18th and 19th centuries

factory-based manufacturing has been associated with pollution and waste. By-products of manufacture have not always been recycled, creating vast landfill around the world. Post-consumer waste, when not readily repurposed or recycled, has led to land and waterway pollution. Designers in all design fields face government regulation, consumer demand and ethical expectations in regard to the environmental impact of their work. However, designers cannot carry all the responsibility for ecological costs as they rely on government provisions for affordable, accessible and reasonable alternatives to wasteful practices.

In built environment design, professionals strive to meet energy efficiency targets that, in turn, influence the choice of materials, construction methods and design. Shifting perceptions of the functions of domestic and commercial building has seen the integration of solar energy, water storage and passive energy use.

For more detailed information on how designers address environmental concerns, see Chapter 13 pages 300–304.

### CHAPTER RECAP



#### Case study 1: Comparison of two design movements

Investigate the application of design elements and principles to graphic design (of items such as movie posters, brochures, packaging) during two periods of history. Using the information gathered, present a written or multimedia presentation that explains the similarities, differences and influences observed.

#### Case study 2: Effects of technology on design

Select two examples of similar products designed in different time periods, such as a television set from 1960 and a contemporary television set, or a 1920s telephone and a contemporary telephone. Compare and contrast the use of materials, and discuss how developments in technology have changed the designs for each product. Present your information in written format or as a digital presentation. To enhance your presentation, use iconography and illustrations in keeping with the periods studied.

### Case study 3: Influences on contemporary design

Investigate the influence that a past design movement continues to have on contemporary design. For example, investigate Futurism and its effect on the contemporary application of letterform in publication design, or the Bauhaus and its influence on contemporary residential architecture. Present your findings as a written report or digital presentation with illustrations and diagrams that clearly indicate the influences.

### Case study 4: Characteristics of a design movement

Design a diagram that depicts the characteristics of a past design movement. Use imagery and examples from key designers of the period. Incorporate visual means to describe the influence that movement has had through history.

### Case study 5: Effects on social change

Investigate the effects of social change on visual communications. Select a key event in history and explore the use of visual communications during that time. Explain how social events had an impact on the content and appearance of visual communications of the time. Prepare a poster that illustrates and describes your research. Use images or freehand illustrations to display your findings.

### Case study 6: Investigation of influences

Select a significant contemporary designer and investigate the influences that have impacted on their design work. Collect examples of the designer's work and create visual comparisons with work created previously. Annotate your findings and indicate the links between the current and past design movements. Present your findings in a digital or written format that reflects the stylistic influences you have investigated.

### Case study 7: Political design

Investigate the use of visual communications in the political spheres. Research the use of design by governments and political organisations in Australia and overseas. Investigate the use of visual communications in a contemporary climate,

comparing and contrasting the uses to identify similarities and differences. Observe the use of design to promote ideas, or focus on electoral or wartime events. To present your findings, design a poster in a style that is typically used for political propaganda.

### Case study 8: Cultural connections

Focus on one aspect of design (such as fashion, product design, graphic design or interior architecture) and investigate the influence of cultural and attitudinal change over time. Study the influences of popular culture (such as music, cinema and television) on design. Establish links between key cultural changes (for example, punk in England during the 1970s) and your focus area of design (for example, Vivienne Westwood and innovations in fashion). Present your findings in diagrammatical format or as a digital presentation.

### Case study 9: Protest and dissent

Investigate the application of graphic design in times of protest and dissent. Select key historical events and analyse the use of visual communications to convey issues and opinions. Collect visual materials from the past (for example, anti-nuclear protest images from the 1980s and mid 1990s). Also seek out contemporary protest graphics and compare the content and style with earlier examples. Present your findings in digital format with visual examples or in the form of a protest graphic.

### Case study 10: Making and hacking

Find examples of Maker culture where the **collaboration** between makers and technology has led to significant design developments. Look at crowdfunding tools such as Kickstarter to find new designs that fit within Maker culture and suggest how it might be used in a wider social context. Create your own design idea using a combination of traditional or artisanal techniques and digital technologies. Conversely, find an existing design, for example a piece of furniture, and suggest how it could be 'hacked' and made into a new products using technologies.



# LEGAL AND ETHICAL ISSUES IN DESIGN

## CHAPTER 13

### In this chapter:

+ Intellectual property .....	287
» Who owns intellectual property? .....	288
» Copyright.....	289
» Moral rights .....	292
» Trademarks.....	293
» Design registration.....	294
» Patents .....	295
+ Creative Commons .....	295
» How to attribute a Creative Commons work .....	295
» Creative Commons licence types .....	296
+ Attribution of research.....	296
+ Standards.....	298
+ Regulations.....	298
+ Use of images.....	299
+ Sustainability .....	300
» Strategies for sustainability .....	301

### Learn the language

appropriation  
artistic craftsmanship  
attribution  
copyright

design registration  
fair dealing  
intellectual property  
moral rights

patents  
standards  
sustainability  
trademarks

As in any professional area, designers need to consider the legal and ethical issues that affect their field. As professionals they have responsibilities towards their clients, users and the wider community.

These issues include:

- + copyright
- + intellectual property
- + standards and safety
- + image manipulation
- + cultural sensitivities.

Legal issues are set; they are issues that are defined by law and cannot be breached without serious consequences. Legal regulations apply to designs created and sold in Australia and might include safety regulations and **standards** that designers are required to adhere to. Ethical concerns are less concrete; they may range from ‘Can I work for this client?’ or ‘Is this a conflict of interest?’ to ‘Does this design negatively impact those who will see it or use it?’

Designers in all design fields need to take legal issues into account in their work. An architect may be required by council by-laws to consider the effects of a design on the community and make aesthetic judgements with those in mind. The same architect has an obligation to create a safe construction for the client, and there are legal implications if safety is compromised. All designers are faced with issues of **copyright** and **attribution**; both in their own work and when using the work of others. Decisions about the use of materials from other sources may be constrained by copyright, costs and licensing restrictions. Likewise, a designer may seek to protect their work under copyright laws.

## INTELLECTUAL PROPERTY

**Intellectual property** is literally, ‘the property of your mind’ and refers to the creative production of a new invention, brand, design or artistic creation. In designing a new product, for example, intellectual property rights enable the designer to legally protect their design idea from copies and imitations. Copyright and **moral rights** are **automatically** applied to artistic works in Australia. Other areas of intellectual property (IP) are not automatically recognised and a product, design idea or concept must be registered for a given period of time, for a monetary cost. Using

ISBN 9780170401784

the Australian government’s intellectual property organisation, IP Australia, designers can apply for **patents**, **trademarks** and registered designs to protect the originality of their work and ideas. IP Australia takes care of four distinct types of intellectual property: patents, trademarks, designs and plant breeder’s rights. The table below outlines the relevant types of intellectual property that is usually registered.

What is protected	Type of IP right	What the IP provides
Art, illustration, literature, music, film, broadcasts and computer programs	<b>Copyright</b> (automatically applied)	The owner’s original expression of ideas is protected, though not the ideas themselves. The owner has the exclusive right to use, sell or license the copyrighted work.
Letters, numbers, words, colours, a phrase, sound, smell, logo, shape, picture, aspect of packaging or any combination of these	<b>Trademarks</b>	A trademark identifies the particular goods or services of a trader as distinct from those of other traders. The owner has the exclusive right to use, sell or license the trademark.
The way a product looks or a design on a manufactured product	<b>Designs</b>	The visual appearance of a manufactured product is protected, but not the way it works. The owner has the exclusive right to use, sell or license the registered design.
Inventions	<b>Patents</b>	The owner has the exclusive right to use, sell or license the invention. Patents also allow the owner to stop others from manufacturing, using, copying and/or selling the device or process.

Adapted from [www.ipaustralia.gov.au/understanding-intellectual-property/how-to-use-ip/what-can-you-protect/](http://www.ipaustralia.gov.au/understanding-intellectual-property/how-to-use-ip/what-can-you-protect/)

IP rights are legally enforceable in Australia and protect many designers from copying and misuse of their designs. Areas of design that benefit from IP protections include:

- + architecture
- + digital media

Nelson Visual Communication Design VCE Units 1–4



- + exhibition design and display
- + fashion design
- + furniture design
- + graphic design
- + industrial design
- + interior design
- + jewellery design
- + landscape design
- + television, film and set design
- + textile design.

## WHO OWNS INTELLECTUAL PROPERTY?

When creating work for a client, the ultimate owner of the design (the intellectual property) is usually established in the contract at the beginning of the

design process. In the majority of cases, the contract between client and designer will state that all intellectual property generated becomes the property of the client in return for design fees.

Although a 'normal' contract would assign all IP rights to the client, a designer might negotiate at the beginning with the client over what will be assigned – and under what payment terms – and then write this agreement into the contract. For example, one option is to agree to assign the IP rights to only the final, selected idea, retaining rights to any other design ideas.

## Copyright infringement: Von Glitschka



US illustrator and designer Von Glitschka maintains a highly visible profile online, at conferences and as an educator. However, his distinctive work has been used at various times without permission.



▲ Original artwork by Von Glitschka, as displayed at [www.glitschkastudios.com](http://www.glitschkastudios.com)

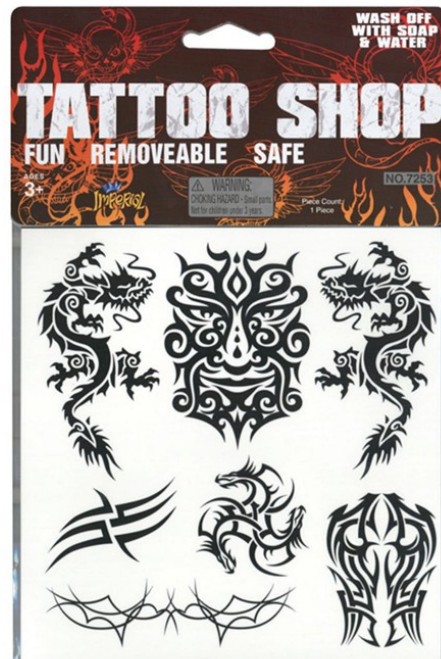

▲ Product that infringed Von Glitschka's copyright

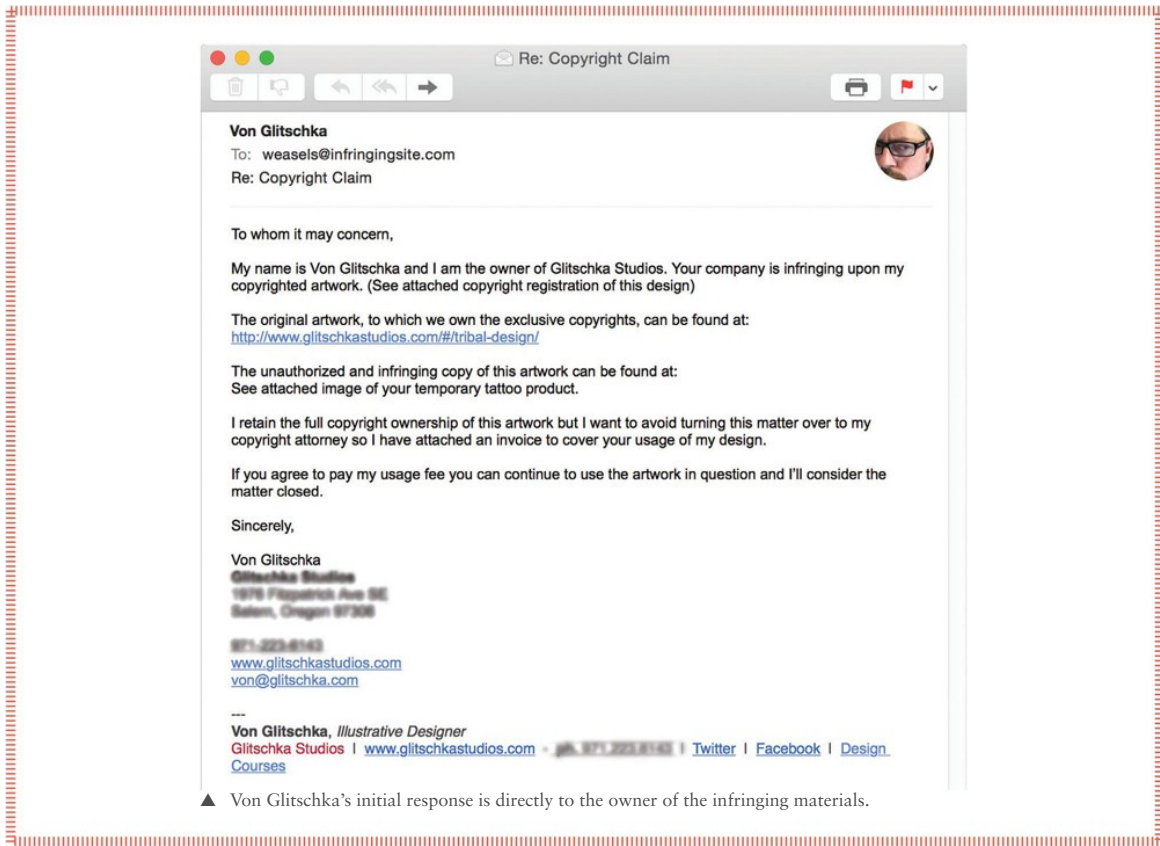

▲ Von Glitschka’s initial response is directly to the owner of the infringing materials.

**LINK: INTELLECTUAL PROPERTY RIGHTS**

The website of IP Australia provides comprehensive information about all areas of intellectual property. The site explains the key differences between copyright and IP rights and offers visual examples of each IP category: patents, trademarks, designs and plant breeder’s rights. You can link directly to IP Australia via <http://vcd.nelsonnet.com.au>.

## COPYRIGHT

Copyright is designed to protect the products created by writers, designers, artists, composers, filmmakers and other creative professionals. In Australia, copyright is automatically granted to a product once it is put into ‘material form’ such as being drawn or



▲ Copyright logo. Even when the logo is not present, copyright still exists under Australian law.

written down. The owner of the copyright has the right to show, publish or perform the work in the public realm and can prevent others from reproducing the work without explicit permission. The copyright owner may sell the rights to that work or ‘assign copyright’ to another party.

- Copyright protects:
- + **artistic works** – paintings, photographs, maps, graphics, cartoons, charts, diagrams and illustrations

- + **literary works** – novels, textbooks, poems, song lyrics, newspaper articles, computer software, computer games
- + **musical works** – melodies, song music, advertising jingles, film scores
- + **dramatic works** – plays, screenplays and choreography
- + **films and moving images** – feature films, short films, documentaries, television programs, interactive games, television advertisements, music videos and video podcasts
- + **sound recordings** – MP3 files, CDs, DVDs, vinyl and tape recordings, podcasts
- + **broadcasts** – pay and free-to-air television and radio.

Copyright does not protect techniques, concepts or ideas but it does protect their tangible physical representation. An *idea* for a textile design featuring original patterns and illustrations, for example, is not copyrighted; however, copyright law covers the sketches, drawings, prototypes and final design product.

The owner of copyright may be separate from the owner of the designed item. An individual may own the design mentioned above yet the copyright to the design remains in the hands of the original copyright owner, who may be the designer or manufacturer.

Many designers use sourced imagery in their work. Copyright images and photographs may be used in publications, websites and other public domains only with the permission of the copyright owner.

## Copyright and design registration: Lumiere Art & Co.



Artist and designer, Emma Cleine juggles multiple intellectual property issues in her business, Lumiere Art & Co. Her unique artworks are automatically protected under copyright law. Her cushions, homewares and other products are protected with a combination of copyright and design registrations.



Lumiere Art & Co.

## THE COPYRIGHT TIMELINE

FYI

Just because a work appears online does not mean that it is out of copyright. For artistic, literary, musical and dramatic works, the period of copyright protection runs from the time of creation until 70 years after the death of the creator. Films, sound recordings and broadcasts are protected for 70 years from the end of the year in which the work was released. Sometimes it takes some searching and research to identify whether creative products are in or out of copyright. Once out of copyright, a work is considered to be 'in the public domain' and can be used freely.

## LINK: COPYRIGHT COUNCIL



The Council supports the copyright needs of creative professionals in Australia. The site offers information organised by profession and features detailed information about all aspects of Australian copyright law. Council members include representatives from the peak professional associations for Australian writers, musicians, photographers, visual artists, journalists, filmmakers and architects. You can link directly to the website of the Australian Copyright Council via <http://vcd.nelsonnet.com.au>.

## Copyright for students

The rules for using copyright-protected materials in education are slightly different. Under Australian law, schools have expanded rights to use copyright materials without seeking permission from the copyright owner as long as content remains within the classroom. This doesn't mean open slather for schools. There are still parameters set as to the amount of copyright works that may be copied, displayed and reproduced but the rules make the use of copyright materials for educational purposes much more flexible.

Sources used by students should always be acknowledged.

When using images, the original source of the image should be acknowledged in an annotation that records

the original author or copyright owner. If the owner cannot be identified and the image has been sourced from an online location, note the web address or use a screen capture to identify the source. This is called attribution.

If student work is to be displayed publicly, there must be clear acknowledgement and attribution of any content used that has not been created by the student.

## DON'T COPY!

FYI

Despite popular belief, it is not OK to change an existing creative work by 10% or 20% and claim that it is no longer protected by copyright. Misuse of copyright material is measured by the term 'substantial'; usually decided on a case-by-case basis. The safest approach is to be inspired but *don't* copy!

## Tips for students using the work of others

Most importantly, always identify the source when using the work of others.

You are entitled to use a 'fair' amount of work from other sources for 'research and study' without gaining permission from the copyright owner; this is known as **fair dealing**. Fair dealing requires that the work is used only for research, criticism, satire and parody, or reporting of news. It is likely that most work used in Visual Communication Design will fall under the 'research and study' area.

You are entitled to use the work of others when you have express permission from the copyright owner to do so. You should have evidence of the permission.

You are entitled to use work with a Creative Commons licence that allows use by others (See the Creative Commons guide on page 295 of this chapter).

## LINK: SMARTCOPYING



This official website is designed for teachers and students at Australian schools and TAFEs. Educational use of resources entails different copyright requirements and these are clearly outlined here. You can link directly to the Smartcopying website via <http://vcd.nelsonnet.com.au>.

## Copyright case study



As part of her Units 3 & 4 SAT folio, Visual Communication Design student Stephanie Hosler created a series of original book covers for a re-issue of classic literary works by Oscar Wilde. Wanting to have her work appear as authentic as possible, Steph contacted publisher Harper Collins and requested permission to include its logo on her designs. Via email, she received permission from the company to use the logo and was able to document the permission in her development work.



Steph Hosler

## MORAL RIGHTS

Established under the Copyright Amendment (Moral Rights) Act of 2000, Moral rights protect the personal connection between creator and work. Moral rights are designed to address issues of misuse, misrepresentation and distortion of original works. They cannot be sold or transferred, and remain with the original creator (except filmmakers) for the period of their life plus 70 years. These rights protect a work's original 'author', a legal term used to describe communication designers, illustrators, craft makers, architects, musicians, writers and other creatives. Moral rights remain with the original creator even when a work is sold. Copyright to a work can be assigned to another person or entity but the moral rights to that work always remain with the original author/creator.

Moral rights law covers three areas, listed in the table at right.

Moral right	What is covered?
Right of attribution of authorship	The original author of the work has the right to be identified. The creator has a right to correct attribution.
Right against false attribution	The original author has the right to pursue legal action against anyone who falsely attributes their work to someone else.
Right of integrity of authorship	The original author is protected against 'derogatory' treatment of their work. Any distortion, destruction, defacement or alteration that may negatively impact the reputation of the author is not allowed.

### LINK: FEDERAL REGISTER OF LEGISLATION



For further details on moral rights, read Copyright Amendment (Moral Rights) Act 2000 No. 159, 2000 at the Federal Register of Legislation. You can Link directly to the Federal Register of Legislation website via <http://vcd.nesonnet.com.au>.

## Moral rights case study



Designer Nicholas Found and illustrator Emma Morgan collaborated to produce a unique illustrated spoon as a gift. Nick hand-carved the spoon from blackwood using traditional tools and techniques. Emma applied her original drawing by hand to the finished spoon form in permanent black ink. Although the item was then presented as a gift, both Nicholas and Emma jointly retain the moral rights to the final design. Any change or modification to the spoon by the recipient would infringe upon the moral rights of the creators.



Nicholas Found

### LINK: AUSTRALIAN ATTORNEY-GENERAL



The official website of the Australian Attorney-General offers information about current copyright law. You can link directly to the Federal Attorney-General's website via <http://vcd.nelsonnet.com.au>.

## TRADEMARKS

Trademarks distinguish the brand or identity of a business, individual or organisation. A trademark may be a symbol, logo, phrase, name, sound, colour or even smell. Registered trademarks are designed to protect an identity from close copying by a competitor within the same market place or goods and services classification. Trademarks are registered by IP Australia within a defined category of goods and services. For example, trademarked Christmas decorations fall under Class 28 and a bank or insurance company

trademark is covered by Class 36. Trademarks can also be registered for distinctive characteristics of a product or service. Famously, Cadbury Chocolate hold registered trademarks for the distinctive purple colour of their packaging and advertising. A patterned design, in the case of David Jones department store's houndstooth design, and a product form such as Coca Cola's distinctive classic bottle are also protected by registered trademarks.

Trademark registration is a complex process and has high associated costs. It is possible to assert a trademark without registration by placing the figure <sup>TM</sup> beside a logo. Whereas, a registered trademark is represented by the ® symbol. A trademark is not compulsory for a brand or product and you may find that some businesses use similar marks, names and phrases within different goods and services classifications. An application for a trademark will be rejected if it is too similar to an existing trademark within the same classification. It is also important for designers to note that Australian trademark registration only applies within Australia.



- ▲ The identity of the Pantone brand is a registered trademark, indicated by the use of the ® symbol.

## DESIGN REGISTRATION

**Design registration** is required when a design has a commercial focus. Three-dimensional designs that would otherwise be protected by copyright, lose that protection when they go into mass production. Subsequently, to protect a design, it may need to be registered with IP Australia. A registered design is protected under law for five years; it covers protection of the visual appearance of a product and allows for exclusive rights to commercially use, license or sell the design. What a design registration does not cover, however, is the function and materials of a design. In registering a design there are three conditions that the product must meet:

- + the design must not have been released or revealed to the public
- + it must have been kept secret and can only be revealed when IP Australia approves the registration claim
- + the design must be **new** and **distinctive** compared to other products, online, internationally and within Australia.

**New** – it must not be identical to any design previously disclosed anywhere in the world. This includes anything published anywhere in the world or publicly used in Australia.

**Distinctive** – it must not be substantially similar in overall impression to any design previously disclosed anywhere in the world. This also includes anything published anywhere in the world or publicly used in Australia.

IP Australia, [www.ipaustralia.gov.au](http://www.ipaustralia.gov.au) 1 March 2016.

Legal rights to the design are only approved once the registration has been ‘certified’ by IP Australia. This is the final stage of the registration process.

## Works of artistic craftsmanship

For many small-scale product designers and makers, design registration is an expensive and cumbersome process. So, according to the Copyright Act, if their work falls under the category of ‘works of artistic craftsmanship’, they are entitled to copyright protection even when their products may be mass-produced. This classification was designed to protect artisan makers such as potters, furniture makers, jewellers, glass artists and other craftspeople. To qualify for protection under this classification is difficult as there are no clearly articulated rules that define ‘artistic craftsmanship’ in the Act itself. However, legal sources have established general guidelines.

- + The work should have an element of real artistic/aesthetic quality (as opposed to being overwhelmingly functional or utilitarian).
- + There must be a sufficient degree of skill and craftsmanship involved in the making of the work.
- + ‘Craftsmanship’ does not necessarily require the article to be solely made by hand (it can be made with the assistance of a machine).
- + Evidence of a conscious intention by the artist to produce a work of art is not essential, but can help.

Givoni, Sharon, 2015, *Owning it: A creative's guide to copyright, contracts and the law*, Creative Minds Publishing, Melbourne.



Sarah Dingwall

- ▲ Glass artist Sarah Dingwall produces glass jewellery, homewares and decorative items from her studio in Mornington, Victoria. Her designs are protected by copyright as she fulfils the guidelines for ‘works of artistic craftsmanship’.

## PATENTS

A patent is a legal protection for inventions. Patents can be applied to traditional inventions such as appliances and mechanical devices as well as computer-related inventions, business methods, biological inventions, micro-organisms and other biological materials. Artistic products and ideas are not covered by patents. Patents are usually applied to highly innovative products that are otherwise unique.

There are two types of patents: standard and innovation.

### Standard patent

A standard patent must be new, involve an inventive step and be able to be made or used in an industry. An inventive step means that the invention is not an obvious thing to do for someone with knowledge and experience in the technological field of the invention. (The) invention must differ in some way from existing technology. This difference must be something more than the simple application of published information or standard background knowledge.

IP Australia, [www.ipaustralia.gov.au](http://www.ipaustralia.gov.au), 1 March 2016.

### Innovation patent

An innovation patent provides protection for an invention with a short market life that might be superseded by newer innovations, such as computer-based inventions.

IP Australia, [www.ipaustralia.gov.au](http://www.ipaustralia.gov.au), 1 March 2016.

Like design registration, patents require an approval and certification process administered by IP Australia and are only valid within Australia. Patents for innovation last for up to eight years, while standard patents last up to 20 years. A patent prevents competitors from producing identical products or systems. Patents and patents pending are identified by a reference number, which can be publicised to deter copycats.

## CREATIVE COMMONS

Creative Commons is an international non-profit organisation that provides free licences to copyright owners to



▲ Creative Commons logo.

allow others to legally share, reuse and 'remix' their material. Creative Commons was created in direct response to the increasing accessibility of materials via the Internet and a perceived lack of control that creators have in the digital domain. A Creative Commons licence is identified by a series of symbols, which indicate the context in which the author of the work is prepared to allow others to use the work. When a creator releases their work under a Creative Commons licence, it is made clear what the user can and cannot do with the work. All Creative Commons licences allow works to be used for educational purposes. Teachers and students can copy, share and often modify a Creative Commons work without seeking permission from the work's creator.





## HOW TO ATTRIBUTE A CREATIVE COMMONS WORK

Include the following:

- + author name
- + title of the work
- + URL where the work was located
- + type of Creative Commons licence attached to the work
- + any copyright notice attached to the work.

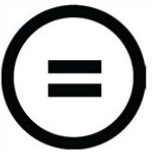

## CREATIVE COMMONS LICENCE TYPES

Symbol				
Meaning and letter code	Attribution BY	Non-commercial NC	Non-derivative works ND	Share alike SA
Description	This applies to every Creative Commons work. Whenever a work is copied or redistributed under a Creative Commons licence, the original creator (and any other nominated parties) must be credited and the source linked to.	Allows others to copy, distribute and perform the work for non-commercial purposes only.	Allows others to distribute, display and perform verbatim copies of the work. The work may not be adapted or changed in any way.	Allows others to remix, adapt and build on the work, but only if they distribute the derivative works under the same licence terms that govern the original work.

### LINK: CREATIVE COMMONS



The organisation supports Creative Commons in Australia and administers the Australian Creative Commons licences. The website features detailed information about licences, including fact sheets and case studies. You can link directly to the website of Creative Commons Australia via <http://vcd.nelsonnet.com.au>.

### LINK: HARVARD REFERENCING GENERATOR



The Harvard Referencing Generator is an online tool that can help you to acknowledge your sources easily and quickly. You can link directly to the Harvard Referencing Generator via <http://vcd.nelsonnet.com.au>. Type in the URL, book title or magazine and the generator will produce a correct citation for you to copy and paste.

## ATTRIBUTION OF RESEARCH

Source attribution is an important skill to learn and there are guides to assist you in correctly documenting your sources. The Harvard system of referencing materials is probably the most widely used.

Generally, the following should be included when attributing non-original content:

- 1 name of the work (if available)
- 2 author and/or copyright owner's name (Usually this should be the surname followed by initial but some

Web content may give you only first name so use what is available or attribute to Anon. if no author can be identified.)

- 3 URL of the work if found online
- 4 the origin of the work, if found in a secondary publication (The name of the publication should be identified along with its date of publication.)
- 5 date of the work
- 6 date of access or download.

Research	Source	Attribution	Example
Images	Online, e.g. Google Images	Avoid annotations that simply state 'Google Images' or another search engine. Navigate to the source site of the image and copy the URL. The attribution should state: owner (if known) <URL of the image> [date it was accessed/downloaded].	Image by Jones, J. available from <www.greatbuildings.com/image_033> [13 May 2018]
Images	Print sources	Include the publication title and date if it originates from a print source. The attribution should state: owner title image and/or the article from which it was sourced name of the print publication date of publication.	Image by Mavis Davis, 'Australia's ten best photographers', <i>Design Journal</i> , Issue 12, 2018 (When annotating an attribution in handwriting, you can emphasise the source by an underline rather than italics, e.g. <i>Design Journal</i> )
Stock images	Online stock photo site	Free stock photo sites will vary in the level of attribution required but most will require the name of the owner of the work. The attribution should state: owner (if known) ID (#) number of the image <URL of the image or stock site> [date it was accessed/downloaded].	Image copyright Dani007 #0436721 <http://sxc.hu> [4 June 2018]
Text	Digital sources, e.g. blogs, Wikipedia articles	Quotes or references directly taken from online sources such as blogs must identify the author and origin. The attribution should state: author title of the blog post or article [date of the blog post or article] <URL of the blog> [the access or download date].	Feagins, L., Interview with Illustrator Dawn Tan [12 September 2011] <thedesignfiles.net> [30 June 2018]
Text	Books	When using research from a secondary source such as a book, you must also add the publisher name and location of publication. The attribution should state: author date of publication title of the book publisher, location.	Martin, B., & Hanington, B., 2012, <i>Universal Methods of Design</i> , Rockport Publishers, USA (The title should be italicised if using a computer but can be underlined when handwritten)
Text	Magazines and journals	The article name must be mentioned and depicted in single quotation marks. The attribution should state: author date of publication title of the article name of the publication issue or volume number and date.	Banham, Stephen, 2012, 'The Typeface: Newman', <i>Desktop Magazine</i> , No. 279 (Italicise the name of the magazine if using a computer, but underline if handwritten)
Creative Commons materials	Refer to Creative Commons on page 295 to read about online content that is covered by the Creative Commons' licence structure.		

## STANDARDS

**Standards** are documented requirements that designers and manufacturers must follow. Standards set out specifications and procedures that ensure that products, services and systems are safe, reliable and consistent. The documents use consistent terminology that defines levels of safety and the quality that products are required to meet. Although standards documents are not legal documents, they are a requirement in Australian design and manufacture and they can be mandated by parliament as compulsory.

There are three kinds of standards: international, regional and national.

### International standards

These are developed by ISO (International Organization for Standardization), IEC (International Electrotechnical Commission), and ITU (International Telecommunication Union). Australia usually adopts international standards.

### Regional standards

These are prepared by a specific region, such as the regional standards between Australia and New Zealand.

### National standards

These are developed by a national standards body. Standards developed under the brand of Australian Standard® are developed within Australia or are adoptions of international standards.

Standards can be published in a range of formats and may include:

- + Australian Standards®
- + international standards and joint standards
- + codes
- + specifications
- + handbooks
- + guidelines.

The Australian Standards® cover many industries including:

- + agriculture, forestry, fishing and food
- + mining
- + manufacturing and processing
- + building and construction

- + electrotechnology and energy
- + water and waste services
- + transport and logistics
- + health and community services
- + consumer products, services and safety
- + education and training services
- + communications, information technology and e-commerce services
- + public safety, public administration and business and management.



- ▲ Australian standards compliance is important in product design and environment design. Many products feature visual identification that they meet Australian standards, along with the code that represents the relevant standard.

## REGULATIONS

Regulations pertinent to environment design, such as building codes and construction regulations are considered at every stage of the design process. Affecting architects in particular, government-sanctioned regulations inform decisions about how a building is to be constructed. Regulations may affect issues such as building height, choice of materials, fire safety, energy efficiency and more. Regulations vary according to state legislation, and local governments can also impose requirements on development and construction. Architects, interior architects and landscape architects are required to address regulatory requirements in their responses to design briefs. Documentation and evidence that all regulations have been addressed and met are an integral part of the design process.



iStockphoto/jandriellombard

- ▲ All building projects in Australia are bound to regulations from Federal, state and local government bodies. Regulations are created to ensure that issues of safety, sustainability and heritage protection are addressed in the earliest stages of the design process.

## USE OF IMAGES

Print media often uses images that have been altered, and the use of software such as Photoshop is often used to retouch and alter the appearance of individuals.



Shutterstock.com/Elena Rudyk

- ▲ Image of a female face before and after Photoshop retouching.

There have been many well-documented cases of celebrities seeking compensation from publishers for overt and exaggerated manipulation of their images. Although there is no specific legislation in Australia that protects people from having their likeness altered without their consent, there are areas of law that offer some protection. Defamation law offers recourse if an individual believes that the alterations to their image

cause ridicule, contempt or a loss of reputation while consumer law protects against deceptive or misleading interpretations of an image. It is important that designers are aware of relevant legislation about image use.

### Appropriation of imagery

The appropriation of imagery and cultural iconography in design is an issue that increasingly affects professionals working in creative fields. Appropriation, or 'borrowing', of visual elements from another culture or subculture, is commonly seen in art but less so in design. Appropriation becomes especially problematic when used for commercial gain. Social media news feeds often feature examples of print and video advertising that have made use of either cultural imagery or stereotypes, only to have the content backfire. Notable examples of commercial appropriation resulting in community backlash include a magazine that used Native American headdresses as accessories for an editorial and a soft drink campaign that re-created imagery of street protestors suggestive of the 'Women's March' and 'Black Lives Matter' protests. Such missteps suggest that the ideas were out of touch with community sentiment. Imagery that is stereotypical is also problematic, particularly in communication design. When visual messages are designed to be absorbed quickly, the use of stereotypes may be an easy method of conveying meaning. However, the most effective designs are those that recognise cultural shifts. Diverse societies evolve in their sociological and demographic makeup, so a stereotype soon becomes outdated, meaningless and sometimes counterproductive. When dealing with educated, active and aware consumers, respectful representations of cultural, gendered and social imagery is a significant ethical consideration.

An example of the appropriation of Native American culture occurred when an image of artist Pharrell Williams wearing Native American headdress appeared on the front cover of *Elle* magazine. The magazine cover sparked controversy and resulted in public apologies from the magazine and the featured artist, Pharrell Williams. Search online for an image of the cover.

### Cultural awareness

In a global marketplace, many designs are sold and used in countries around the world. But, what is appropriate in one market may not work in another due to cultural or religious sensitivities. For example,

the ‘thumbs up’ symbol has positive connotations in western countries but has less clear meanings in some Middle Eastern societies. A designer may not be aware of the distribution of a design, however if a design is likely to be used in varied markets it is the designer’s responsibility to ensure that the product is not culturally offensive or misleading. Such considerations reinforce the importance of building a solid understanding of the end user.

### LINK: ETHICS IN GRAPHIC DESIGN



Ethics in Graphic Design is a US forum for the discussion of ethical issues in graphic design. Issues range from social responsibilities in design to privacy and copyright. You can link directly to the website via <http://vcd.nelsonnet.com.au>.

## SUSTAINABILITY

In 2012, the Australian Government outlined its vision for a sustainable Australia and settled on three distinct indicators of **sustainability**: **social**, **environmental** and **economic**. The notion that sustainability reaches into most aspects of contemporary life is shared among academics, governments and organisations globally; it is a complex and evolving issue.

### Social sustainability

Targets for social sustainability aim to ensure the long-term availability and access to education, health and employment, which provide both personal and community security and wellbeing.

### Environmental sustainability

Environmental sustainability aims to ensure that the natural environment is monitored, protected and managed and refers to climate, land and ecosystems, water, waste and natural resources.

### Economic sustainability

Economic sustainability applies to the maintenance, development and management of factors including

wealth and income, transport and infrastructure, productivity and business innovation.

Along with governmental recognition of the need for action on sustainability, individuals and communities have developed a high level of awareness of sustainable practices. Greater knowledge of the human impact on the environment has led to significant and identifiable shifts in expectations from consumers and users of designed products.

Design, by its creative and innovative nature, is primed to respond to change and, in many areas, has adapted to the demands of sustainable practices. Design professionals have played a major role in bringing the design of energy-efficient homes, the application of renewable resources in product design and the use of sustainable materials into the mainstream. Design has been used to build public awareness of issues relevant to the achievement of sustainable targets and graphic design has played a major part in the communication of these ideas.

The minimisation of waste and the application of ‘life-cycle principles’ in design are issues that face professionals in the industrial, built environment and graphic design fields. One of the implications of designing products for mass consumption is the increased waste due to high production volumes. The choices made by designers about materials, packaging, energy use, waste and recyclability may reflect their personal and professional values but may also be influenced by the expectations of both client and end user.

Increasingly, the use of ethical, sustainable and appropriate materials is an expectation of informed consumers. In all fields of design, professionals consider the long-term impact of their decisions in the earliest stages of the design process. Cost considerations may constrain the selection of materials used in a design; however, advances in ‘green’ and ‘eco-friendly’ materials development may now offer wider choices.

In some areas of design, the use of sustainable products and the application of energy-efficient and environmentally friendly practices are mandated by law. Standards set by government bodies including Standards Australia may specify that the design of products and particularly that of buildings must have strict environmental codes applied. Built environment designers are often required to respond to constraints related to sustainable issues.

transGlass by Tord Boontje and Emma Woffenden for Artecnic



▲ transGlass® recycled glass by Emma Woffenden and Tord Boontje, 2006.

### LIFE CYCLE ASSESSMENT

FYI

Life cycle assessment (LCA) is a technique used in industrial design for assessing the environmental impacts of a product across its entire life cycle. The life cycle references the period of time from extraction of base materials, through the design and manufacturing process, to the use and final disposal of the product. The life of a product is also referred to as cradle-to-grave design; designs that are fully recyclable at their end of life are referred to as cradle-to-cradle designs. Observations of a product's life cycle can tell a researcher or designer about the burdens a product or service place on the environment.



## STRATEGIES FOR SUSTAINABILITY

### Recyclability

Consideration of the recyclable nature of materials is important in product design. The more parts of the product that can be recycled or can be manufactured from recycled materials the less the impact of the product. The reuse of products for their original purpose is known as recycling (e.g. excess building bricks used for paving or on a new construction); the conversion of recycled products into a new product for a new purpose (e.g. plastic drink bottles into non-slip mats) is called downcycling.



Suek UK Ltd, www.suek.uk.com



Suek UK Ltd, www.suek.uk.com

▲ The Bottle Light is a fully rechargeable led light that can repurpose empty bottles into long-lasting lights.

## Multifunctional design

Products with more than one function can increase the value for the owner. A product designed for one purpose could be reused for a different function. For example, packaging might be able to be reused for a different product such as storage. If a product has multiple functions, fewer products are needed. Consumers may view products that have multiple functions as having higher value and retain them for longer periods of time.



Image courtesy of Marjan van Aubel, photo by Mathijs La badie

- ▲ The Current Table by Dutch designer Marjan van Aubel incorporates solar cells. It functions as both a working space and a charger for electronic gadgets.

## Materials selection

An effective sustainable approach is to select non-toxic, recyclable and low-impact materials in the first place. All materials have a Materials Safety Data Sheet (MSDS) that can be used to assess suitability and impacts. Hazardous and toxic substances are best avoided but if they are to be used, identifying appropriate means of disposal at end of life is essential.

## Durability

Designing quality products that are built to last means less waste in the long term. Quality products are more likely to be reused, repaired, resold or recycled. The longer a product lasts, the less likely it is to be replaced. Designing for longevity requires careful selection of materials and the use of processes that ensure solid and enduring construction. The appearance of a design can communicate its longevity;



Memobottle, Designer: Jesse Leeworthy, Co-founder Jonathan Byrt



Memobottle, Designer: Jesse Leeworthy, Co-founder Jonathan Byrt

- ▲ Locally designed product Memobottle uses non-toxic materials including BPS-free plastic. The materials selection is free of hazardous substances, comes packaged in recycled cardboard and \$1 from each purchase is donated to a clean water charity.

design that appears durable and long lasting helps to reinforce its durability. Extending the life of a design may reduce consumption and waste.



Fairfax Syndication/The Age/Gary Medlicott

- ▲ Shipping containers are durable and long lasting. They have been adapted for a range of uses, including housing. This is the 'Small is Smart' house, Portarlington Road, Leopold, Victoria. Fabricated from disused shipping containers. Brainchild of Geoff Fulton and Carla Salomon of Fulton and Salomon Architects, 3 June 2009

## Dematerialisation

Reducing the amount of material used in a design is a straightforward way of minimising environmental impact. Similarly, reductions in the weight, volume and size of product can lead to less waste at end of life. An example is housing design that uses a minimal range of materials.



HAY, Denmark

- ▲ The Nobody chair by HAY design is moulded from one piece of material. Using a technique borrowed from the car industry, the chair is manufactured from two layers of thermos-pressed PET felt – a 100% recyclable material made from used water and soda bottles. The chair is stabilised without using an internal frame, plastic, screws, glue or other reinforcements.

## Efficiency

Products, particularly those that use electricity, need to be efficient in their use of energy. Creating ‘standby’ or ‘sleep’ functions reduces power use. Designs might encourage users to turn off or unplug by using automatic switches or timers. Cost-aware consumers are often attracted to energy-efficient products.

## Disassembly

Products that are designed to be easily taken apart at their end of life can make the recycling process more efficient. Consideration in the early stages of a design



istockphoto/Kokkai Ng

- ▲ The Commons is a medium-density, residential building located in Brunswick. Completed in 2014, its use of sustainable materials, shared facilities and innovative design led to worldwide recognition as well as many architecture and environment awards. At the core of its design, which has no car parking and shared laundry facilities, is a focus on environmentally sustainable, financially viable and socially responsible practices.

about the structure and functionality of a product can predict the speed and ease of taking it apart for recycling.



Studio David Grass

- ▲ This cardboard lounge, designed by David Grass, comes flat-packed for assembly. If disposal or storage is required, the design can be completely disassembled.



## Degradability

Materials that can be broken down organically through composting are known as degradable materials and can be used in some products. These include paper, cardboards and starch-based plastics. Glass, metals and petrochemical-based plastics take many years to degrade and are best recycled or reused.



Greenmark eco packaging range/  
greenmarkpack.com.au

- ▲ Traditionally, food packaging is a high contributor to landfill waste. These packages, using a combination of sugar cane bioplastics, are fully compostable. Polylactic acid (PLA), a renewable bioplastic derived from corn starch or sugar cane, enables packaging to be waterproof and heatproof and also degradable.

## Product responsibility

Increasingly, companies are encouraged to take full responsibility for their products. In recent years and, in some cases, due to consumer or government pressure, companies have introduced policies designed to address issues with the end of life of products. Recycling schemes and returns procedures enable products to be remanufactured or recycled.



Shutterstock.com/SandyS

- ▲ What to do with used coffee pods is a dilemma posed by the popularity of coffee pod machines. Nespresso offers a recycling program and accepts returns of their used pods in prepaid post satchels and at designated collection points. The pods, which are made from aluminium, can be fully recycled. In Europe, the Nespresso 'second-life' recycling program has seen the pods recycled into car parts, cookware and cans. The coffee grounds have also been repurposed as rich garden compost.

## LINK: SUSTAINABLE DESIGN



There are many web resources available that outline strategies that designers can undertake for more sustainable and efficient design products. You can link directly to the companies below via <http://vcd.nelsonnet.com.au>:

Design can change

United Nations D4S: Design for Sustainability

Treehugger (the latest contemporary and sustainable designs in many design areas).

## CHAPTER RECAP



- 1 You have created illustrations and typography to be used on the album cover for a friend's band. You did not accept financial payment for the design but accepted a number of complimentary albums in return for your work. Who has copyright protection for the album cover?
- 2 Creative concepts and ideas are protected by copyright law in Australia. True or false?
- 3 You find that an image of your face has been used in an online advertising campaign without your permission. What are your rights under Australian copyright law?
- 4 In working for a large graphic design studio, you create the cover of a new textbook. The cover design is your own work and features illustrations in your distinctive personal style. Who owns copyright under Australian law?
- 5 In designing a website for a client, you wish to use a photographic image from a 1926 book about Art Deco architecture. What are your copyright obligations?
- 6 Walking through a market, you see a stall selling T-shirts that feature a clear image of an illustration you created and posted on social media. What steps can you take to address this issue?
- 7 An image you wish to use in a design is labelled 'royalty-free'. Do you still have to acknowledge copyright?
- 8 In your Year 12 Viscom folio you wish to use images of the Nike 'swoosh' logo. What are

you required to document in your folio under Australian copyright law?

- 9 In allowing a close friend to use one of your illustrations as the identity of their new blog, you shake hands in agreement. Do you still own copyright of your image?
- 10 You have provided permission for your imagery to be used in a new school textbook. On publication you notice significant changes to the image and it appears distorted. Explain your moral rights in this situation.
- 11 As an industrial designer you have created a visually unusual and innovative vegetable peeler. The appearance and shape of the peeler is unlike any other product on the market. How can you protect the uniqueness of your new design under Australian law?
- 12 Architectural plans are not protected under Australian copyright law. True or false?
- 13 If you pay someone to use an image that they have created, who owns copyright under Australian law?
- 14 If you change 20% of an image by using Photoshop, it is no longer covered by copyright law. True or false?
- 15 If you are prepared to pay enough money, it is possible to purchase the moral rights to an artwork. True or false?



PART D

# STUDY RESOURCES

# COURSEWORK AND TASK PROMPTS

CHAPTER

14

---

## In this chapter:

+ Unit 1 .....	308
» Area of study 1 Drawing as a means of communication .....	308
» Area of study 2 Design elements and design principles ....	309
» Area of study 3 Visual communication design in context...	309
+ Unit 2 .....	311
» Area of study 1 Technical drawing in context.....	311
» Area of study 2 Type and imagery in context .....	312
» Area of study 3 Applying the design process .....	312
+ Unit 3 .....	314
» Area of study 1 Analysis and practice in context.....	314
» Area of study 2 Design industry practice .....	315
+ Units 3–4 folio .....	316

For more detailed tasks and classroom activities, see *Nelson Visual Communication Design VCE Units 1–4 Workbook, Edition Three*.

---

# UNIT 1

## AREA OF STUDY 1 DRAWING AS A MEANS OF COMMUNICATION

### Coursework options

#### Option 1: Domestic appliance

- 1 Select a domestic appliance, for example an iron, toaster, handheld vacuum, lamp, etc.
- 2 Complete an isometric drawing of the selected appliance.
- 3 Complete a third-angle orthogonal drawing of the selected appliance.
- 4 Complete a rendered two-point perspective observational drawing of the object depicting shadows and textures.
- 5 Design a simple packaging solution for the object.
- 6 AND/OR Create a one-point perspective drawing of the packaging.
- 7 Scan and present your drawings on a digital presentation designed to promote the appliance.

#### Option 2: Recreation equipment

- 1 Select an item that can be found in a sporting or outdoors retailer; for example, a water bottle, kayak, kerosene lamp, torch or headlamp.
- 2 Complete an exploded isometric drawing of the selected object, showing parts.
- 3 AND/OR Complete a planometric drawing of the product.
- 4 Create a rendered one-point perspective or two-point perspective drawing of the product in an in-store display showing materials, textures, highlights and shadows.
- 5 Complete a third-angle orthogonal drawing of the product.
- 6 Scan selected drawings to create a 100 × 150 mm postcard to be sent to VIP customers of the store.

#### Option 3: Fashion accessories

- 1 Select a fashion item such as a shoe or handbag.
- 2 Complete a rendered two-point perspective observational drawing of the product showing textures and materials, shadows and highlights.
- 3 AND/OR Complete a one-point perspective drawing of the object from a different viewpoint and include additional objects to depict scale.
- 4 Create a packaging net or orthogonal drawing of a point-of-purchase display unit to promote the product.
- 5 Create planometric AND/OR isometric drawings of the display from different viewpoints.
- 6 Use digital means to create surface graphics for the display unit that feature a depiction of the product.

#### Option 4: Packaging

- 1 Select an item of food packaging from your pantry or the supermarket.
- 2 Complete an observational drawing of the packaging using rendering to show texture and form.
- 3 Complete a one-point perspective or two-point perspective drawing of the packaging within its normal environment (e.g., on a shelf).
- 4 If possible, unpack the packaging and draw the packaging net.
- 5 Using a combination of drawing and digital media, create new surface graphics for the packaging that would appeal to a new audience.

#### Option 5: Stationery design

- 1 Select a very simple stationery object for redesign such as a pencil sharpener or stapler.
- 2 Complete four drawings of the single object: isometric, planometric, one-point perspective and two-point perspective.
- 3 Render each drawing to show some different materials, for example wood, metal, plastic and glass.
- 4 Complete an orthogonal drawing of the object, including a section view.

# UNIT 1

## AREA OF STUDY 2 DESIGN ELEMENTS AND DESIGN PRINCIPLES

### Coursework options

#### Option 1: Minimalist poster

Investigate the application of design elements and design principles in the design of posters (film, event, festival). Annotate researched examples to indicate how elements and principles have been applied to communicate a message and to attract a target audience. Using a range of design elements and design principles, generate ideas for a poster for an existing event, movie or festival. Develop and refine the most appropriate concept, emphasising the effective application of elements and principles.

#### Option 2: Logo design

Devise a fictional school event such as a fancy-dress formal, charity fun run or Christmas fair. Generate a range of logo concepts for the event using visualisation drawing and a range of design elements and design principles. Experiment with media, methods and materials to develop the most effective and suitable logo for the event. Expand the design by creating a logo system including a logo-based pattern, signage, an app interface and social media icon.

#### Option 3: Clothing brand

Using templates for clothing items such as a T-shirt, cap and sneakers, create a clothing line for men and women using repeated imagery, patterns or icons. The designs should use a range of design elements and design principles. Generate design ideas that can be applied creatively to the clothing items and which use multiple elements and principles. Research and annotate clothing brands that use distinctive designs in their textiles and graphics. Present the final designs in two alternative colour stories (two colour options).

#### Option 4: Promotional postcard

Design a 100 mm × 150 mm postcard advertising a new release by your favourite band or singer-songwriter. Use a photographic image of the performer (in black and white) as the basis of your design. Design eight alternative compositions that each use one dominant design element and one dominant design principle. Ensure that you cover all eight elements and all eight principles in your concepts. Evaluate and decide on the design that best represents the musical style of your chosen music artist. Using your preferred media and method, for example, collage, create the final presentation of your postcard.

#### Option 5: Food packaging

Using a template of a soft drink can or other drink packaging, develop surface graphics for a healthy drink alternative to energy drinks. Develop six to eight alternative designs, using combinations of design elements and design principles. Annotate each design alternative, indicating the placement of elements and the application of principles. Evaluate how effectively each design would be in appealing to a youth market. Scan your preferred concept or recreate it using appropriate software. Apply your design to the template.

# UNIT 1

## AREA OF STUDY 3 VISUAL COMMUNICATION DESIGN IN CONTEXT

### Coursework options

Select one or combine case studies for a broader task.

#### Case study 1: Comparison of two design movements

Investigate the application of design elements and principles to graphic design (of items such as movie posters, brochures, packaging) during two periods of history. Using the information gathered, present a written or multimedia presentation that explains the similarities, differences and influences observed.

### Case study 2: Effects of technology on design

Select two examples of similar products designed in different time periods, such as a television set from 1960 and a contemporary television set, or a 1920s telephone and a contemporary telephone. Compare and contrast the use of materials, and discuss how developments in technology have changed the designs for each product. Present your information in written format or as a multimedia presentation. To enhance your presentation, use iconography and illustrations in keeping with the periods studied.

### Case study 3: Influences on contemporary design

Investigate the influence that a past design movement continues to have on contemporary design. For example, investigate Futurism and its effect on the contemporary application of letterform in publication design, or the Bauhaus and its influence on contemporary residential architecture. Present your findings as a written report or multimedia presentation with illustrations and diagrams that clearly indicate the influences.

### Case study 4: Characteristics of a design movement

Design an explanatory diagram that depicts the characteristics of a past design movement. Use imagery and examples from key designers of the period. Incorporate visual means to describe the influence that movement has had through history.

### Case study 5: Effects on social change

Investigate the effects of social change on visual communications. Select a key event in history and explore the use of visual communication during that time. Explain how social events had an impact on the content and appearance of visual communications of the time. Prepare a poster that illustrates and describes your research. Use images or freehand illustrations to display your findings.

### Case study 6: Investigation of influences

Select a significant contemporary designer and investigate the influences that have impacted on their

design work. Collect examples of the designer's work and create visual comparisons with work created previously. Annotate your findings and indicate the links between the designer and their influences. Present your findings in a digital or written format that reflects the stylistic influences you have investigated.

### Case study 7: Political design

Investigate the use of visual communications in the political spheres. Research the use of design by governments and political organisations in Australia and overseas. Investigate the use of visual communications in a contemporary climate, comparing and contrasting the uses to identify similarities and differences between them. Observe the use of design to promote ideas, or focus on electoral or wartime events. To present your findings, design a poster in a style that is typically used for political propaganda.

### Case study 8: Cultural connections

Focus on one aspect of design (such as fashion, product design, graphic design or interior architecture) and investigate the influence of cultural and attitudinal change over time. Study the influences of popular culture (such as music, cinema and television) on design. Establish links between key cultural changes (e.g., punk in England during the 1970s) and your focus area of design (e.g., Vivienne Westwood and innovations in fashion). Present your findings in a diagrammatical format or as a digital presentation.

### Case study 9: Protest and dissent

Investigate the application of graphic design in times of protest and dissent. Select key historical events and analyse the use of visual communications to convey issues and opinions. Collect visual materials from the past (e.g., anti-nuclear protest images from the 1980s and mid 1990s). Also seek out contemporary protest graphics and compare the content and style with earlier examples. Present your findings in digital format with visual examples or in the form of a protest graphic.

## UNIT 2

### AREA OF STUDY 1 TECHNICAL DRAWING IN CONTEXT

#### Coursework options

##### Option 1: Industrial design

**Step 1:** Using one of the products listed below, create an appropriate two-dimensional presentation: orthogonal or packaging net.

**Step 2:** For the same product create an appropriate three-dimensional presentation: paraline or perspective.

**Step 3:** Design a presentation format that features both drawings clearly labelled (poster, brochure, digital presentation). Add rendering to the three-dimensional drawing to indicate light, shade and shadow, and to represent surface textures and materials.

Select from the following products:

**Step 4:** Extension. For an additional challenge, design a diagram that depicts HOW the product can be constructed using an exploded view.

Appliances/homewares	Packaging	Tools	Transport
washing machine	liquid packaging, e.g. UHT milk, juice packs	lawnmower	bicycle
blender	aluminium packaging, e.g. soft drinks	drop saw	car
toaster	food packaging	cordless drill	moped
iron	cosmetic and toiletry packaging	pressure cleaner	jet ski
lamp	fast food packaging	staple gun	sailboard
furniture, e.g. chair, bed, table or sofa	recycled/recyclable packaging	saw	surfboard
cordless telephone		screwdriver	skateboard
coffee grinder		hammer/mallet	van
kettle		wrench	truck
children's toys, e.g. puzzles, blocks		toolbox	scooter
clock		guillotine	tricycle
handheld vacuum			toy car
			trailer
			motorhome/caravan

##### Option 2: Environmental design

**Step 1:** Create a series of plans (including a landscape plan) and elevations for one of the following:

- + small house
- + beach box
- + boatshed
- + mobile home
- + luxury camping/safari tent
- + garden or tool shed

- + dog kennel or other animal shelter
- + cubby house
- + tree house
- + relocatable snack bar
- + garage
- + retail kiosk
- + information booth
- + concert venue
- + gazebo
- + carnival sideshow.



**Step 2:** Create a three-dimensional presentation of your chosen structure or dwelling. Render to indicate light, shade, and shadow, and to represent surface textures and materials.

**Step 3:** Create a presentation that features the two-dimensional and three-dimensional drawings that you have completed.

**Step 4:** Extension. For an additional challenge, draw a section view or cutaway view of your dwelling.

## UNIT 2

### AREA OF STUDY 2 TYPE AND IMAGERY IN CONTEXT

#### Coursework options

##### Option 1: Send a message

Generate ideas for a poster or webpage for a public awareness campaign around an important issue (for example, swimming pool safety, smoke alarm maintenance). Use a combination of type and imagery to develop two alternative designs; one that presents a positive message with humour, another that presents an emotive message. Present both designs with annotations explaining how the message might be conveyed using such different techniques for capturing attention.

##### Option 2: All about you

Design the covers and spine of your autobiography. Create a theme, write a blurb, title and subtitle that captures the personality of the book subject. Use imagery and type that effectively combine to 'tell a story' about the subject. Research existing designs and comment on the effectiveness of type and image to convey meaning. Present your design as a flat cover and on a 3D template of a blank book.

##### Option 3: Animal crackers

Design packaging for a line of pet treats. Use images of domestic pets and include appropriate typography and imagery to devise creative and appealing graphics that represent each animal. Adhere to a consistent theme across at least three packages while distinguishing each through image and text. Research existing packaging

designs and comment on the use of type and image to present brand values.

##### Option 4: Music everywhere

Select three musical artists of your choice. Using distinctive typography and images (taken by you), design artwork for the merchandise listed below. Adapt each design to suit each context and modify type and image appropriately. Maintain a visual connection between each of the four artwork applications.

- + New album artwork to be applied to vinyl collector's edition. *Album artwork dimensions: 310 mm × 310 mm*
- + Artwork for the same album, for display on streaming media such as Spotify. *Online artwork dimensions: 1600 pixels × 1600 pixels*
- + Promotional concert poster. *Poster dimensions: A3*
- + Promotional artwork for the same concert but for sharing and display on social media. *Social media event artwork dimensions: 1920 pixels × 1080 pixels*

##### Option 5: Easy as ABC

To assist young children in learning the letters of the alphabet, design a typeface that illustrates each letter with objects that start with the same letter. For example, design an innovative glyph for 'K' that also represent 'kite'. Generate a range of alternative ideas before creating your final alphabet. Consider using a reduced colour palette that would appeal to the young audience. Produce the final designs using cut paper or create a vector version on software such as Adobe Illustrator.

## UNIT 2

### AREA OF STUDY 3 APPLYING THE DESIGN PROCESS

#### Coursework options

Each of the following design briefs contains a clearly defined communication need. Follow the design process to research, develop, refine, evaluate and produce final presentations.

**Option 1 Design brief: Product design**

Design a multifunction seat/table that can be used by students in a small shared house or apartment. The target audience is young people in rented accommodation with limited space for large furniture items. Create a multifunctional product that can enable relaxation, eating and study without requiring multiple pieces of furniture.

**Option 2 Design brief: Logo design**

The Coffee Addict Cafe, located in the central business district (CBD) of the city, requires a logo suitable for a range of purposes, including external signage, takeaway cups, aprons, menus, serviettes and a website. The cafe attracts professionals, both men and women, who work in the CBD and are aged from 25 to 45. The cafe sells a wide range of coffee-related products. It sees itself as offering delicious hot beverages, and identifies its values as sophisticated and European in style. The logo, which is to be in two colours only, should reflect this.

**Option 3 Design brief: Digital icon design**

A music website requires the design of a series of music genre icons to assist users to navigate the site. The icons may cover music genres such as hip-hop, electronica, dance, classical, blues and R & B, plus more. The icons should feature imagery and typography used creatively to reflect the characteristics of each music style. Four sample icons should be designed. The target audience is young, tech-savvy users who want the latest music releases as well as older users looking for older songs.

**Option 4 Design brief: Sneaker design**

An urban streetwear company is launching a series of three designer-inspired shoes. Each shoe design is to be influenced by a significant design from the past and present. The designs may be applied to the surface or influence the overall form of the shoe. A range of design elements and principles should be applied.

**Option 5 Design brief: Poster design**

Create an A3 poster for an upcoming film festival. The festival is for short films shot entirely on mobile devices

and phones. The poster should be highly appealing to the target market of amateur filmmakers and film lovers in the age range of 16 to 24 years of age and should indicate the nature of the festival. The poster should use visual means to explain location, time and conditions of entry. Type should be used to explain details.

**Option 6 Design brief: Packaging design**

The Black Cat shoe company requires an identity and surface graphics for use on the packaging of their products. Aimed at a teenage market and designed for both a male and female audience, the shoes are stylish and fashion forward. The packaging of the shoes should be contemporary and appealing to the market; the purchasers may be as attracted to the packaging as they are to the product. The packaging should be reusable, so it may have more than one purpose. The surface graphics should reflect the interests and fashion consciousness of the audience while also conveying key information such as size and colour.

**Option 7 Design brief: Point-of-purchase display design**

Your favourite performer (or author) is about to release a new single (or podcast or audiobook). The digital product will be available online but it is also to be promoted nationwide in music stores and/or electronics retailers. A point-of-purchase display is required; this will sit at counter level to promote the launch. The target audience is you! The display should be no greater than A4 in size and should feature all relevant information, including the artist's name, the launch date, the title of the release and information about where the item is available for download. You should use imagery, colours and type that have a high appeal to the target market.

**Option 8 Design brief: T-shirt design**

A radio station requires a promotional T-shirt to launch its new brand. The T-shirt should be appealing to young men and women aged 16+. The content displayed on the T-shirt should reflect the contemporary and popular music styles played by the radio station. It should use three colours only and be youthful and dynamic. The radio station identifies its brand as young, energetic and focused on new music – with a touch of rebellion. The artwork can cover the front, back and sleeves of the shirt.

**Option 9 Design brief: App design**

Airpod Ltd is a newly established travel company specialising in the development of sleeping ‘capsule’ or ‘pod’ hotels within international airport terminals. Based in Australia, Airpod aims to improve the travelling experience by providing a safe, comfortable and affordable space to rest in-between flights. The company wishes to develop a pod design that is innovative and far removed from the clinical and uncomfortable nature of airport gate lounges. The pods will suit a youthful, budget-conscious, tech-savvy user. The company envisages the function of the pods to be driven by a downloadable app; it requires an app design that is clear and easy to use. The first range of pods will be introduced into Australian and Southeast Asian airports with hopes of further expansion in the future.

**Option 10 Design brief: Wayfinding system and website**

Melbourne’s Museum of Ancient History has become one of the city’s most popular destinations

for tourists and locals alike. The museum’s approach to educating and entertaining visitors about ancient civilisations has made it a standout attraction in Melbourne’s CBD. The museum aims to make its exhibitions more interactive for visitors, with fun activities for children and adults, virtual reality simulations of historical events and replicas of exhibited artifacts that are safe to play with. The museum requires an innovative wayfinding system to guide visitors around the exhibits. Additionally, the museum wishes to revamp its website/app offerings and enable users to engage before, during and after their visit.

**UNIT 3**

**AREA OF STUDY 1  
ANALYSIS AND  
PRACTICE IN CONTEXT**

Visual communications for analysis might include:

Communication design	Environmental design	Industrial design
Advertising material	House	Domestic appliance
Book covers	Apartment	Lighting
Brochures	Cafe or restaurant interior	Furniture
Diagrams	Institutional design	Tools
Fashion and clothing	Landscape	Electronic equipment
Illustrations	Playground	Personal electronic device
Magazine layouts	Sports/Recreation centre	Toys
Maps and charts	Domestic interior	Scale models
Multimedia imagery	Architectural models and plans	Transport
Packaging		Office products and stationery
Postcards		
Posters		
Signage		
Symbols and logos		
Websites		

Using information gained from the analysis of visual communications in the three design fields, produce three visual communications:

<b>Communication design</b>
Maps
Packaging
Symbols
Advertising
Charts
Logos
Illustrations
Brochures
Freehand drawing
Posters
Diagrams
Publications
Graphs
Infographics
Clothing
Signage
Exhibition displays
Multimedia
Motion graphics
<b>Industrial design</b>
2D and 3D drawings
Engineering drawings
Concept presentations
3D scale models
<b>Environment design</b>
Architectural drawings
3D scale models
Multimedia
Maps
Diagrams
Concept presentations
Plans
Digital 'walk-through'

## UNIT 3

### AREA OF STUDY 2 DESIGN INDUSTRY PRACTICE

#### Coursework options

This task may be a written report, short or extended responses, structured questions or an annotated written report. Your teacher will inform you of the procedure for the completion of written outcomes.

Suggested examples of professional practitioners are as follows.

- + Architect
- + Automotive designer
- + Exhibition designer
- + Fashion designer
- + Communication/graphic designer
- + Illustrator
- + Industrial designer
- + Interior architect
- + Landscape designer
- + Multimedia designer
- + Product designer
- + Set designer
- + Web designer.

#### Option 1: Analysis

Using resources provided by your teacher, such as interviews and videos, identify the specialist skills applied by the designer to the completion of a design brief.

Analyse the relationship between the client and the designer, and explain the impact of that relationship on the design process.

Describe the process undertaken by designers in the evaluation and assessment of the design concepts.

Your teacher may provide question sheets, or you may be required to take detailed notes for later use.

#### Option 2: Interview

Interview a designer and establish how they use a design process in the development and production of visual communications to fulfil a design brief.

Give examples of the designer's application of a design process.

Describe how the visual means (such as media, methods, materials, design elements and design principles) are decided upon and applied.

Discuss the constraints and restrictions faced by the designer in working within the framework of a design brief.

### Option 3: Studio visit

Visit a design studio and observe the role of each person working on a specific project or task.

Describe the role of each member of a design team.

How are input and the communication of ideas expressed?

How are ideas developed and refined within a design team?

Discuss the relationships that designers have with external contractors and specialists. Give examples.

### Option 4: Case study

Using a resource such as *Ideas on Design*, describe the steps a designer takes in the development and production of a visual communication solution.

Use visual means to describe the process.

Explain each phase of the design process in reference to the original design brief.

Describe the methods applied in the design, and the development of concepts and final visual communications.

Explain methods and techniques used in the evaluation of the final design.

### Option 5: Visual presentation

Create a brief presentation of a case study, created by you, explaining the design process as applied by a professional designer.

Use visual means to describe the process and show examples.

Show clear links between the brief and the design process, and indicate where outside professionals were employed to complete the tasks.

Indicate methods used in evaluation of the final design.

### Option 6: Written test

Undertake a written test prepared by your teacher.

Complete short-answer questions that cover the key knowledge and skills required by this outcome.

To assist with your answers, observe visual resource material, such as images that show a design process.

Questions may include reading case studies, answering comprehension questions and making an analysis of visual materials supplied by designers.

## UNITS 3–4 FOLIO

A design problem requiring a solution is the core of the design brief. The suggestions on pages 317–319 can be used to form the design brief for your folio. Remember that you must create TWO distinct final presentations that meet the needs of the design brief.

Client	Communication need 1	Communication need 2
School of the Arts	The design of a corporate identity/logo for the school applicable to a wide range of carriers including uniforms, stationery, web, signage and promotional materials	The design of multipurpose classroom spaces suitable for visual and performing arts education. The presentation of plans, elevations and rendered 3D views
Council Homeless Initiative	The design of a portable/demountable temporary accommodation option for homeless Melburnians. The presentation of plans, elevations and rendered 3D views	A brochure or poster communicating the features and functions of the accommodation to key stakeholders in government and non-government organisations
Fashion magazine	Invitation and innovative packaging/postage design for VIP invitees to the launch of the magazine	Cover design and multipage editorial spread including photography and text for inclusion in the launch issue
Hybrid sports car	The design of the body shape and features of a hybrid sports car with consideration of traditional sports styling. 2D and 3D technical drawings and rendered presentation drawings required or a 3D model	Design of a state-of-the-art charging facility for the car when recharging the electric functionality. Rendered drawings of the charger in situ required
Gourmet food truck	The design of a food truck showcasing contemporary and innovative new cuisines to be used at festivals and markets. The truck is a mobile vendor that attracts passers-by and provides a culinary experience for diners with a temporary dining area. Consider the link between the cuisine and the interior/exterior spaces. Produce plans, elevations and interior renderings of the spaces	Design of an identity for the truck. The identity will be applied to an app (so users can find the truck location), signage, decals, packaging and staff uniforms
Dance company	Typeface and poster design for the promotion of a new dance event to tour throughout Australia. Final poster and related free postcards to be created	Set design for the dance production that reflects the desired theme. Renderings, elevations and plans required
Museum/Gallery	Exhibition design for an upcoming exhibition about a significant historical event or issue. Considerations of movement and presentation of artefacts required. Plans, elevations and rendered concept drawings to be presented	The design for a collectible souvenir available for purchase at the museum shop. The souvenir should capture the theme of the exhibition and have strong appeal to the target audience. A 3D render or scale model would be appropriate
Furniture design company	The design of outdoor furniture that is collapsible for easy storage during winter	Pattern design for application to cushions, tableware, drinkware and flatware (plates, bowls) for use when entertaining in the outdoors
Extreme video camera	The design of a waterproof and shockproof camera for use in the outdoors and for the filming of extreme sports experiences. Presentation of technical drawings and rendered views of the design	Point-of-purchase structure design for the promotion of the camera in sports stores and outdoor/camping retailers
Relocatable bar or nightclub	Based on a shipping container, the interior design of a bar for use at music festivals around Victoria	Corporate identity advertising merchandise for use in the bar including coasters, menus, and for the promotion of the bar including flyers
Green fashion label	The design of clothing using recycled fabrics and repurposed garments. The production of garments and design of a 'lookbook'	The interior design of the flagship store for the label including plans and rendered elevations

Client	Communication need 1	Communication need 2
Beverage company	Packaging design of new health drink developed to improve metabolism	Design of identity and promotional motor vehicle for public events
Fitness company	Interior design of the gym area, including areas for weight training, cardio and aerobics classes	Corporate identity for the health club to be applied to a range of carriers including uniforms for staff
Food and wine festival	Promotional website, including information about events and special guests	Design of a food stand for the showcase event of the festival. Stand should be flexible and offer cooking facilities
Online music label	The design of a series of icons and graphics for use on the website identifying the functions of the site. Presentation may include a mock-up of the website	Innovative vinyl record packaging for promotion to professional DJs. Packaging may include album and additional information in a fold-out 3D form
Commuter transport terminal for airport	The design of a comfortable and mixed purpose bus shelter for use at an international airport	The design of maps, diagrams and information graphics to assist travellers to locate and make use of the shelter/terminal
Bike manufacturer	Design of a commuter bicycle designed to encourage increased use of cycling by university students	Design of an inflatable bike helmet that acts like an airbag to address the reluctance of some people to wear helmets
Beach cafe	The interior design of a beachside cafe with outdoor seating area on the sand. The cafe may have a sustainable focus and use recycled materials in its design	The design of an identity for the cafe including signage, menus and a webpage
Hikers' hut	The design of a secure and safe overnight camping shelter for hikers on the Great Alpine Trail. The shelter should be in keeping with the protected natural environment	The design of a weatherproof 'survival pack' for hikers. Contents might include things to assist in addressing first aid needs, hunger and communication
Roller derby team	The design of a new uniform for a roller derby team based in Melbourne. The uniform should address safety concerns while retaining the style and aesthetic of this contact sport	The design of a clubhouse for the roller derby team. The design should include areas for fitness training and socialising. Murals and other visual features should be incorporated into the design
Independent music artist	The design of imagery and identity for the musician/singer-songwriter suitable for both traditional retail and online sales. The identity is to be applied to CDs and other merchandise including a webpage or social network	The design of a press release to inform the music press of an upcoming album launch. The release should be eye catching, memorable and stand out amidst considerable competition
Building developer	The design of a relocatable housing unit or loft-style structure, designed to utilise empty, commercial rooftop spaces in densely populated urban centres. The design should accommodate small households who are interested in sustainable building. Presentation of plans and rendered elevations in context are required	Multipage editorial spread in a leading architectural magazine, explaining and depicting the features of the housing unit
Educational toy manufacturer	The design of a stimulating educational toy for use by young children in the early years of learning. The toy may be in the form of a puzzle or game and offer educational benefits. Presentation of technical views and rendered images of the design	Packaging design for the promotion of the toy. Designed for display in a retail environment, the packaging should be appealing to children and parents alike. A scale model of the packaging with surface graphics applied

Client	Communication need 1	Communication need 2
Water sports company	The design of an innovative motorised watercraft that can be used above and below the surface of waterways. The craft may also offer watertight storage for snorkelling and fishing gear. The production of 2D and 3D technical drawings required	Design of the logo identity for the product, and the production of a promotional brochure that explains the functions and features
Retail centre	The design of a temporary retail kiosk for a shopping centre. The kiosk may be used to sell seasonal products such as Christmas gifts or decorations, Valentine's Day products, etc. Plans and elevations are required. A scale model of the kiosk may be suitable	The design of pattern and imagery to be applied to the kiosk in the form of banners, digital imagery or other promotional media
Book publisher	The design of a series of book covers for a popular trilogy or book series. The covers should feature an appealing visual relationship in the use of imagery and typography. Versions of the covers and/or promotional materials such as posters for use in store may be created	The design of a point-of-purchase display for the in-store promotion of the new series. The point-of-purchase display should offer an eye-catching and tactile experience for the user/viewer. 2D technical drawings and renderings of the POP display in the context of the retail space. A model may also be suitable
Dance company	Typeface and poster design for the promotion of a new dance event to tour throughout Australia	The design of a series of props that are to be used as part of the production (defined by theme). 2D and exploded views could be created
Government agency	The design of an information pack or smartphone/tablet app for young people travelling overseas for the first time. The pack may include safety and security information, contact details and advice for inexperienced travellers. The content should be engaging and memorable	Design of a pickpocket-proof wallet or extra-secure daypack/backpack for travellers to use while away OR design the 'ideal' youth hostel to be constructed in a popular resort area. Elements might include safety considerations, secure areas and zones for different interests, ages and experiences. Rooms and whole floors may be designed and decorated in distinctive and creative styles



# GLOSSARY

**abstract** Imagery that does not realistically represent life

**alignment** The position of text or images in a composition in relation to a grid or axis

**analysis** Written or verbal study of the meanings, relationships and features of visual communications

**animation** A series of images arranged in a timed sequence suggesting continuous movement

**annotation** Explanatory notes that accompany visual concepts

**anti-alias** To reduce the jagged and pixelated appearance of low-resolution images

**Art Deco** Design style characterised by the use of geometric shapes and forms

**art director** An individual with responsibility for managing the creative and production process usually within a design studio or advertising agency

**Art Nouveau** Design movement characterised by decorative, organic forms and inspired by Asian art

**Arts and Crafts** Decorative arts movement that rejected industrial forms in favour of nature-inspired design

**ascender** In typography, the parts of lower-case letters that rise above the x-height, for example, b, d, f, h, k, l, and t

**attribution** To identify the source, author or copyright owner of original material

**audience** The end user or viewer of a visual communication

**axis** An imaginary straight line around which compositional elements are grouped

**balance** In visual communications, a harmony between elements of a composition

**baseline** In typography, the horizontal line upon which the main body of the type sits. Rounded letters actually dip slightly below the baseline to give optical balance

**bezier** In computer graphics software, the bezier (or pen) tool draws curved line segments that can be reshaped by changing its anchor points and/or direction lines

**bitmap** Another term for raster. Images which use a grid of small squares of data (pixels) to create an image

**body text** Term used to describe type used for long passages of text, such as articles in a newspaper or magazine or chapters in a book

**brainstorming** To stimulate creative thinking or expand on an idea by applying small, stimulating tasks

**branding** A unique name or image that represents a product

**CAD/CADD** Computer software that allows designs to be explored and analysed in detail before construction

**client** The initiator of a design process. The client usually identifies the design problem or need.

**CMYK** The four process colour inks: Cyan, Magenta, Yellow and Black

**collaboration** A group of people working together to achieve an outcome

**collage** Method of pasting shapes cut from materials including paper and newsprint onto a surface

**colour** The most dominant and influential of all the design elements

**colour mode** The type of colour required for digital images, usually CMYK or RGB

**column** In graphic design, a vertical 'container' for text and visual elements

**composition** The arrangement of design elements and visual information on a surface

**concept/conceptual** An idea concerned with ideas rather than the concrete

**constraints** Creative restrictions placed upon a designer, usually outlined in the design brief

**construction** The building of a model or structural design

**contemporary** Belonging to the current era

**content** The subject matter of a visual communication

**context** The circumstances surrounding a visual communication, that is, its physical location

**contour** A line that traces the outer surfaces and form of an object

**contrast** Application of opposing elements for visual effect

**copyright** In Australia, copyright is automatically applied to original artistic works. Copyright protects tangible artistic products, not ideas. In most instances, copyright lasts for the life of the creator plus 70 years

**crating** The use of construction lines and shapes to build form. Often used in paraline and perspective drawings of complex objects.

**creative thinking** The generation of a wide range of different design ideas

**critical thinking** The development of concepts and ideas

**cropping** The removal of visual material to enhance visual impact

**crosshatching** Rendering technique that uses overlapping diagonal lines to suggest tone

**culture** The ideas, customs and behaviour of a group of people or a whole society

**Dada** A group of reactionary artists, poets and writers that originated in Zurich, Switzerland

**design brief** Written or verbal instruction to a designer outlining a design task. It features information including the client need, design constraints, audience, purpose and context.

**design element** A building block that we use to construct a composition; one of the fundamental components of a composition. There are eight design elements: colour, form, line, point, shape, texture, tone and type.

**design field** A specific area of design, with its own language, traditions, origins and influences: for example, industrial design, environmental design and communication design

**design principle** A principle that directs how we use design elements to develop a composition

**design registration** Provides protection for mass-produced products that are new and distinctive. Functional and utilitarian products, produced in significant quantities (guidelines suggest over 50) are not protected under copyright and require registration. Some mass-produced designs qualify as ‘works of artistic craftsmanship’ and are protected by copyright.

**diameter** A straight line that passes through the centre of a circle from one side to the other

**digital drawing methods** To create images with graphics software programs

**digital imagery** Images created electronically

**dimensions** Written measurements placed on a technical drawing

**dot rendering** Rendering technique that uses uniform dots of colour to create tone

**dpi** Dots per inch. Used in inkjet printing. Refers to the number of dots per square inch of image

**elevation** A drawing that shows the front, rear or side of something

**empathy** The ability to understand the feelings of another person

**ergonomics** The study of human factors such as comfort and usability in product and interface design

**ethical** Issues relating to the moral principles of a person or society

**evaluation** Assessing effectiveness

**fair dealing** Under copyright law, the use of copyright material for research, criticism, satire or news purposes

**figure-ground** One of eight design principles, which describes the relationship between dominant and non-dominant elements of a composition

**file type** Name given to a specific type of file, such as TIFF, JPEG, PNG or EPS files, most commonly used for digital images

**foreshortening** Drawing technique that visually indicates objects that are closer to the viewer

**form** The shape of three-dimensional objects

**freelance** To work independently rather than as an employee of a design business or other organisation

**function** The intended purpose of something; the way it will operate or work

**golden section** Mathematical calculation also known as golden mean. Refers to the height to width ratio between elements of a composition

**gouache** Opaque, water-based paint

**grid** An invisible structure or scaffold that supports the layout of print and digital content

**gutter** The spacing between columns of type

**hierarchy** The establishment of an order of importance

**highlight** To identify areas that reflect light and therefore feature little or no tonal information

**horizon** The defined meeting point of earth and sky, or equivalent planes in perspective drawing

**human-centred design** A design approach that prioritises the needs of the end user

**humour** In visual communications, humorous content can encourage positive interaction from an audience

**icon** Symbolic or sacred imagery that represents a concept

**ideation** The process of generating new concepts

**illustration** Creative and varied visual techniques used to depict objects, concepts, emotions and meanings

**influences** The external factors that have an impact on visual communications

**intellectual property** IP is the term that covers legal protections for creative works. As with private property, IP owners have rights regarding attribution, use and misuse of their original works

**interaction** The way in which things relate to each other

**isometric drawing** Paraline drawing method where the length and width are drawn at 30°

**kerning** The manipulation of space between individual letters of a typeface

**layout** The arrangement of visual elements, usually in a two-dimensional context

**leaders** Dimension lines with a single arrowhead

**leading** The distance between two lines of type

**legibility** The visual clarity of text

**light source** Where light is coming from, for example, the sun, a lamp or light globe

**line** A mark or stroke

**manual drawing methods** To create by hand, using instruments such as pencils, rules and set squares, drawings that communicate construction or function

**margin** The white space that surrounds a composition (top, bottom and sides) and separates the design/artwork from the edge of the composition

**marker** A repeating element that assists navigation on a page. It may be a page number, footer or an icon

**mark making** The placement of marks on a surface that form together to create an image

**material** The surface or substrate that a visual communication is applied to or constructed from

**media** The digital and non-digital applications used to make visual communications

**methods** The manual and digital processes used to make visual communications

**minimalism** Style of design where decoration and detail are minimal. Shapes, spaces and forms are 'clean' and uncluttered

**mixed media** The application of different materials and methods in the production of an illustration

**mock-up** A replica of an object made to clarify and refine the design before production

**modelling** To create a smaller three-dimensional version of an object, either manually or digitally using 3D modelling software

**modernism** A design aesthetic characterised by the use of modern materials (such as steel and glass), the application of abstract forms, the manipulation of space and a conservative colour palette

**module** Grid areas defined by columns and flowlines

**moral rights** Moral rights are protected under Australian law to ensure that the works are correctly attributed to their creator and used in a manner that

maintains their integrity. Almost all moral rights, like copyright, last for 70 years after the death of the author/creator

**movement** In design, a key influential development with its own characteristics and key designers

**multimedia** The use of varied software packages to create digital products using sound and vision

**multipurpose** Visual communications that feature a range of purposes

**opacity** The density of a colour or tonal value

**opaque** Not transparent

**organic** Irregular shapes based on and inspired by natural shapes and form

**paraline drawing** Drawing method where all lines remain parallel

**patents** Patents provide protection for inventions that are innovative and very different to existing products. They are not suitable for artistic works or ideas

**pattern** The repetition of elements within a composition

**perspective drawing** Drawing method in which objects appear to recede to given points in the distance

**pixel** A very small unit of visual information in digital form

**planometric drawing** Paraline drawing method where the length and width are drawn at 45°

**point** A unit of measurement used in typography. One point is 1/72 of an inch or 0.352 millimetres

**postmodernism** A complex term used to describe the progressive architecture, design, literature, visual communications, music, sociology and film that has evolved since the 1960s. The postmodernism movement was a reaction against the perceived structural constraints of modernism, and is characterised by decoration, ornamentation and experimental approaches to design.

**ppi** Pixels per inch. Used in software. Refers to the number of pixels per square inch of image

**practice** Techniques, systems and functions common to a professional occupation

**primary purpose** The main purpose of a visual communication

**proportion** The relative scale of objects in relation to each other

**prototype** Experimental model designed to test and evaluate a design

**proximity** Placement of elements close together, creating a visual relationship

**radius** A straight line from the centre of a circle to the circumference

**raster** Images made of pixels, for example, scanned images and digital photographs. Raster software includes Photoshop

**reaction** Response to a visual communication

**refinement** A stage of design development, when the appearance of a final design is clarified, and decisions are made about elements such as colour and methods of production

**reflective thinking** A thinking tool used to judge what can be learnt from the design experience or design outcome

**rendering** The use of tone and colour in drawing to create texture, surface detail and form

**resolution** The quality of a digital image, determined by the number of pixels per square inch (ppi)

**RGB** Colour system for capturing images on a digital screen: Red, Green, Blue

**sans serif** Typefaces that do not have serif 'feet', for example, Helvetica

**scale** The ratio between the size of something real and that of a model or representation

**secondary purpose** An additional purpose of a visual communication

**serif** A counterstroke on letterforms, projecting from the ends of the main strokes, like feet, for example, Times New Roman

**shadows** Areas of comparative darkness, indicated by dark tones

**shape** One of the key elements of design

**shock imagery** Explicit or suggestive material deliberately used to gain consumers' attention

**sketching** Making a rough drawing of the main features of something in the early stages of design

**skills** The ability to expertly do a particular activity or job

**SLR camera** Single lens reflex camera suitable for all types of photography

**spacing** The distance between typeset words or lines

**specialist** A professional in a particular, specialised area of design or other industry

**standard** Guideline for consistent safety and quality controls, set by international bodies and Standards Australia

**stock** Another name for the paper which something is printed on; different thicknesses of stock are measured by weight in grams per square metre (gsm)

**studio** A design studio may be a small partnership or a large organisation that employs a design team

**style** A particular kind, sort or type in reference to appearance

**stylised** Visual communications that appear to be structured around a set of compositional rules

**subjective** Not objective. Displaying personal judgements and feelings

**substrate** The printing surface, such as paper, card, etc.

**surface** The exterior face of an object

**sustainability** Issues related to materials, processes and resources and their impact on the community, environment and economy

**symmetry** Visual elements mirrored on either side of an invisible axis

**tapered** An object that gradually becomes smaller towards one end

**target audience** A group of people for which a visual communication is specifically intended

**terminology** A set of words related to a specific subject

**texture** The appearance or feel of a surface or substance

**third-angle projection** A method of orthogonal representation in which each view is positioned in the drawing so that it represents the side of the object in the view beside it

**thumbnail** Small sketch used to generate ideas quickly

**tonal scale** The range of grey variations from white to black

**tone** The play of light or shadow on an object

**tracking** The distance between letters in typeset words

**trademark** A trademark is the representation of a brand. Trademarks are registered by IP Australia according to their relevant goods and/or services category, for example, jewellery, furniture. A trademark can lapse if not used and must be renewed every 10 years.

**type** Text-based visual elements

**type style** within a typeface, used for a special purpose/ meaning; for example, bold, italic, light, compressed, normal (Roman)

**typeface** the 'family' of a particular type design, e.g. Helvetica or Calibri

**user** The recipient/participant/audience of a visual communication

**vanishing point** Point on the horizon where lines appear to converge

**vector** Images made from paths: lines and shapes. Created in programs such as Illustrator

**view** A representation of surfaces in orthogonal drawing. Common views in third-angle projection are front, top, right and left-hand sides

**viewpoint** The position from which an object or drawing is viewed

**visual diary** Bound sketchbook used as a workbook for developmental drawings

**visualisation** Loose, unfiltered representations of ideas around a theme or idea

**visual metaphor** The use of sometimes unrelated images to impart a message or meaning to a visual communication

**visual thinking** Tools for stimulating critical and creative decision making in the development and production of visual communications

**visual weight** ‘Heaviness’ or ‘lightness’ of elements (including white space) within a composition

**wayfinding** The design and use of maps and signage

**white space** Areas of a composition without visual material. Can create balance and visual weight

**x-height** The distance between the baseline of a line of type and the tops of the main body of lower-case letters, excluding ascenders or descenders (for example, the height of a lower-case ‘x’ or ‘e’)

# INDEX

## A

abbreviations (plans and elevations) 38–9  
 accessibility in design 225  
 acrylic 57–8  
   for modelling 145  
 acrylic paint 137–8  
 additive colour mode 154  
 ‘additive’ printing 144  
 adjacent solid planes, crosshatching 32  
 advertising 70–1  
   guidelines 227  
   methods 226–30  
 advertising posters 126  
 Aesthetic Movement (1870–1900)  
   264–5  
 aesthetic perfection 110  
 affinity diagrams 210  
 age (audience) 163, 218  
 airbrush rendering 51  
 alignment 98, 132  
 alternating patterns 108  
 American Moderne 272  
 ampersand 115  
 analogous colours 80  
 analysing visual communications 230  
   advice for effective analysis 230  
   audience 233–5  
   context 232–3  
   design elements and design principles  
     235–6  
   media, methods and materials 237–8  
   purpose 231–2  
 angular features, dimensioning 35  
 annotating design ideas 177  
 annotating research 175  
 anti-aliasing 152  
 Anti-Design 274  
 appropriation of images 299  
 architects 258  
   what do they do? 255  
 architectural exteriors 16  
 architectural interiors 16  
 architecture 253  
 arrowheads (dimension lines) 33  
 Art Deco (1920–39) 271–2  
 Art Nouveau (1880–1910) 265–6  
 artisanal craft 276–8, 283  
 artistic craftsmanship, works of 294  
 Arts and Crafts Movement (1850–1914)  
   264  
 ascenders 115  
 asymmetrical balance 99  
 attribution 287, 291, 292  
   of research 296–7  
 audience 162, 218  
   categorisation 219–20  
   characteristics 162–3, 218–19  
   fashion and trends 222–3  
   human factors in design 223–5  
   understanding the 218–26  
   user analysis 225–6  
   of visual communications, analysing  
     233–5

audience collage 220–1  
 audience research 170, 220–2  
 axes 97–8  
**B**  
 backing up 148  
 balance 97–8  
   asymmetrical 99  
   symmetrical 98  
   using white space: ‘less is more’  
     99–100  
 balsa wood 146  
 Banham, Stephen 128  
 baseline 115  
 Bauhaus (1919–33) 249, 269–70, 280,  
   281  
 Bezier tools (imaging software) 150–1  
 Biomorphism 272  
 bitmap programs 50, 51, 147, 148, 152  
 Blackletter typeface 119, 124  
 blank page syndrome, overcoming 64  
 blogs 171, 222  
 BMP files 153  
 body text 116, 120, 121  
 books  
   early 124  
   for research 173, 244  
 bowl 116  
 brainstorming 176, 179, 206, 208  
 brand identity 74  
 brand power 229–30  
 built environment design 253–5, 294,  
   300

## C

CAD (computer-aided design) programs  
   38, 41  
 CADD (computer-aided design and  
   drafting) software 144, 145, 256  
 calligraphic typefaces 96–7  
 cameras 155, 157–8  
 carbon fibre 59  
 cartoons 94, 111  
 case 116  
 Caslon, William (and son) 125, 126  
 casting (models) 146  
 centre line (dimensioning circles) 34  
 ceramics 60  
 chalk pastels 138  
 circles  
   dimensioning 34, 35  
   and ellipses 20–1  
 classical architectural conventions 253  
 client 162  
 client research 170, 243–4  
 CMYK colours 82, 83, 142, 143, 154  
 collage using mixed media 139  
 collecting research 170–1  
   where to look? 170–1  
   where to start? 170  
 colour fashion 82, 222–3  
 colour production/management 82  
   CMYK 82, 83, 142, 143, 154  
   digital design 154–5  
   making the right choices 154–5  
   RGB 82, 142, 154  
   web safe colours 154  
 colour swatches 83  
 colour wheel 79, 80  
 coloured pencils 49, 136  
 colour(s) 79–84  
   complementary 80  
   contrast in 101–2  
   cool 81  
   harmonious 80  
   perspective drawing 10  
   power of 81  
   primary 79  
   secondary 79  
   spot 83  
   tertiary 79  
   to stimulate and sedate 81–2  
   warm 81  
 columns 130  
 Comic Sans 129  
 comics 121  
 communication design 246–7  
   presentation drawings 66–7  
   presentations 201  
   visual communication use 76  
 communication designers 258  
   resources used 248–9  
   specialist skills of 248  
   what do they do? 247–8  
   who do they work with? 248  
 compact cameras 157  
 complementary colours 80  
 complex objects, drawing 21–3  
 composites (materials) 59  
 composition 129–32  
   dummy text 120  
   photographs 156  
   typefaces 119  
 computer-aided design 127, 284  
 computer rendering 50–1  
 concept boards 175, 202  
 concept maps 175, 176, 206–8  
 concrete 59  
 cone 21  
 conferences 244  
 Connare, Vincent 129  
 constraints (design brief) 163–4  
 Constructivism (1917–35) 268, 281  
 context  
   of the design 163  
   observational drawing 47  
   of visual communication, analysing  
     233–4  
 contrast 100–1  
   in colour 101–2  
   in line 102  
   in point, shape and form 102–3  
   in tone and texture 102  
   in type 101  
 contrasting colours 80  
 cool colours 81

copyright 287, 289–91  
 case study 292  
 and Creative Commons 295–6  
 and design registration 290  
 infringement 288–9  
 and moral rights 292  
 for students 291  
 timeline 291  
 tips for students using the work of  
 others 291  
 what it protects 289–90  
 corrugated cardboard 145  
 cotton and fibre papers 138  
 counter 116  
 coursework and task prompts 308–19  
 craftsmanship, artistic 294  
 crating method 22–3  
 Creative Commons 295  
 how to attribute a work 295  
 license types 296  
 creative thinking 205, 206  
 techniques 206–9  
 critical thinking 205–6, 210  
 techniques 210–15  
 cropping 103–4  
 cross-sections (orthogonal drawings) 30  
 crosshatching 31–2  
 cutting plane 31  
 crosshatching 31, 50  
 on adjacent solid planes 31  
 on cylindrical objects 32  
 indicating large sections 32  
 crowdfunding 251–3  
 cube 21  
 cultural and religious beliefs 163, 218,  
 263  
 cultural and religious sensitivities over  
 images 299–300  
 curves, drawing 22  
 cutting plane, orthogonal drawings 31  
 cylinder 21  
 cylindrical objects, crosshatching 32

**D**  
 Dada (1916–23) 267–8  
 De Stijl (1917–31) 127, 269  
 decorative typefaces 96, 120  
 defamation law 299  
 degradability 304  
 dematerialisation 303  
 demographic data 173–4  
 depiction 71–2  
 descenders 116  
 design  
 culture and religion 163, 218, 283  
 economic influences 280–1  
 and the environment 284  
 historical context 262  
 political change impact on 281  
 social context 282–3  
 and technology 283–4  
 design brief 161–4  
 audience 162–3  
 client 162  
 constraints 163–4  
 context of the design 163  
 in professional environments 243  
 purpose 163

design elements  
 analysing 235–6  
 colour 79–84  
 form 84–6  
 line 86–8  
 point 88–9  
 shape 89–91  
 texture 91–3  
 tone 93–5  
 type 95–7  
 design field  
 communication design 246–9  
 environmental design 253–60  
 industrial design 249–53  
 design groups or movements 279  
 design history timeline, 1850–current  
 day 263–79  
 design magazines 279  
 design movements 262–78  
 identifying historical contexts  
 279–80  
 design personality 208  
 design principles 97  
 analysing 235–6  
 balance 97–100  
 contrast 100–3  
 cropping 103–4  
 figure–ground 105–7  
 hierarchy 104–5  
 pattern 107–10  
 proportion 110–12  
 scale 112–13  
 design problem 162  
 design process 161  
 design brief 161–4  
 developing concepts 184–91  
 evaluation 191, 197–200  
 generating ideas 175–83  
 pitch as an evaluation technique 203  
 refinement of ideas 191–7  
 research 164–75  
 resolution and production  
 201–2  
 design process in professional  
 environments  
 design brief 243  
 design and production 244–5  
 evaluation 245  
 research 243–4  
 design products, researching similar  
 170  
 design registration 287, 2994  
 works of artistic craftsmanship 294  
 design studios 242  
 design thinking 205  
 creative thinking 205, 206–9  
 critical thinking 205–6, 210–15  
 reflective thinking 206, 215–16  
 designers  
 use of historical sources 262  
*see also* communication designers;  
 environmental designers;  
 industrial designers  
 Deutscher Werkbund (1907–35) 266–7  
 developing concepts 184–91  
 DfE (Design for the Environment) 274  
 diameter 34

digital cameras 155, 157, 158  
 digital design 127, 147–55  
 anti-aliasing 152  
 colour management 154–5  
 image types 147–8, 153  
 preparing images 152  
 resolution 152–3  
 Digital Design (1984–present) 276  
 digital images 171  
 digital imaging software, key aspects  
 148–51  
 digital modelling 147  
 digital patterns 109  
 digital photography 155  
 digital printing methods 142, 143–4  
 digital sketching 62  
 digital typefaces 120, 127  
 dimension lines 33  
 dimensioning (orthogonal drawings)  
 32–6  
 angular features 35  
 circular details 34, 35  
 dos and don'ts 36  
 elements of 33  
 measurements in millimetres 33  
 multiple dimensions 34  
 plans and elevations 41  
 sections 34–5  
 tapered features 35–6  
 dimensions (two-point perspective) 14  
 disassembly 303  
 dominant hierarchy 104, 105  
 dot rendering 49, 89  
 DPI (dots per inch) 142, 143  
 dramatic contrast 101, 102, 103  
 drawing complex objects 21–3  
 drawing curves 22  
 drawing elevations 39–40  
 interior elevations 41  
 step-by-step guide 39–40  
 drawing methods 134–40  
 acrylic paint 137–8  
 collage using mixed media 139  
 gouache 137  
 marker rendering 50, 140  
 observational drawing 44–8, 134,  
 178–9  
 oil and chalk pastels 138  
 paper and card 138–9  
 pen and ink 138  
 pencil 136  
 presentation drawing 64–8, 135  
 visualisation drawing 62–4, 134–5,  
 179–83, 208  
 watercolour 136–7  
 drawing to generate ideas 178  
 observational drawing 178–9  
 visualisation drawing 179–83  
 dummy text 120  
 durability of products 302

**E**  
 ear 116  
 early books 124  
 early typefaces 125  
 Eco Design (1970–present) 274  
 eco materials 58, 300

economic influences on design 280–1  
 economic sustainability 300  
 efficiency of products 303  
 Egyptian typefaces 96, 120  
 electronic resources 171  
 elevations  
   drawing 39–40  
   planometric drawings 6  
   rendering 41  
   two-dimensional drawings 37  
 ellipses 22  
   and circles 20–1  
   isometric 21  
 emotional response 229  
 empathy 229  
 environmental design 253–5, 294  
   drawing the plan view 37  
   planometric drawings 8  
   plans and elevations 37  
   presentation drawings 64–6  
   presentations 201  
   symbol conventions 38  
   three-dimensional view from a floor  
   plan 17–18  
   two-dimensional drawing 37–9  
   visual communication use 76  
 environmental designers 258–9, 260  
   research 256  
   resources used 256  
   specialist skills of 256  
   who do they work with? 256  
 environmental drawing, rendering  
   elevations 41  
 environmental sustainability 300  
 EPS files 153  
 ergonomics 85, 223–4  
 etching (intaglio printing) 140–1  
 ethical issues in design 245, 287, 299–300  
 evaluation (design ideas) 191, 197–200,  
 245  
   pitch as an evaluation technique 203  
   purpose of 197  
   and reflective thinking 215  
   tips for 198  
 evidence, use of 230  
 existing products (research) 165  
 experimentation (design) 185–9  
 experts, asking 172  
 exploded views 6  
 exteriors (two-point perspective) 16  
 eye level 11

**F**  
 fabrics 54–6  
 face *see* typeface  
 fair dealing 291  
 family (type) 116  
 fashion and trends in design 222–3, 262,  
 282  
 fashion design 54–6, 109  
 fashion illustration 112  
 fibre products 59  
 field trip 166  
 figure–ground 105–7  
 film cameras 157  
 filters (imaging software) 149–50  
 first-angle projection 26

floor plans  
   planometric drawings from 8–9  
   two-point perspective drawings from  
   17–18  
 flowlines 130  
 foamcore 145  
 focus groups 169  
 font 95, 116  
 foreground–background 105–7  
 foreshortening 20, 46–7  
 form 84–6  
   contrast in 102–3  
   light source 51–2  
   rendering to represent 48, 49, 51–2  
   variables impacting on 84  
 ‘form follows function’ 85  
 form–counterform 105–77  
 found materials (resources) 171  
 free postcards 171  
 freehand sketching 62, 179–83  
 freelance designers 242  
 front view (orthogonal drawing) 26,  
 27, 37  
 Frutiger, Adrian 127  
 Futurism (1909–30) 267, 2881

**G**  
 gender (audience) 162, 218  
 generating ideas 175–7  
   annotating your design ideas 177  
   drawing to generate ideas  
   178–83  
 geometric sans serif typefaces 120  
 geometric shapes 89, 90, 102–3  
 Gestalt theory 105  
 GIF files 153  
 Gill, Eric 127  
 glass 56  
 glossary 320–3  
 glyphs 95, 115, 124  
 golden ratio 110  
 gouache 137, 138  
 graphic typefaces 120  
 Great Depression 280  
 Green Design 274  
 greylead pencils 48, 49  
 grid formats 131  
 grids 129–31  
 Grotesque/Grotesk 117  
 guiding 74–5  
 Gutenberg, Johannes and the printing  
 press 124–5  
 Gutenberg Bible 124, 125  
 gutter 130

**H**  
 hand-drawn typographic style 128  
 hand modelling 145  
 handwritten type 96, 124, 127–8  
 harmonic ratios 110  
 harmonious colours 80  
 Harvard system of referencing 296–7  
 hidden detail (orthogonal drawings) 30  
 hierarchy 104–5  
   perspective drawing 47–8  
 historical influences on design 262  
 historical resources 173

history of typography 124–9  
   developments in 18th and 19th  
   centuries 125–6  
   digital design 127  
   early books 124  
   early typefaces 125  
   Gutenberg and the printing press  
   124–5  
   handwritten type 96, 124,  
   127–8  
   20th-century modernism 126–7  
 horizon line 11, 12  
 human factors in design 223–5  
 humanist sans serif typefaces 120  
 humanist typefaces 119, 125  
 humour 227–8

**I**  
 ICT, key facts to remember 148  
 idea box 211  
 idea diagrams 176  
 ideation stage 176  
 identifying (brand or product) 74  
 identity 74  
 identity design 90, 91  
 illuminated manuscripts 124  
 illustrations 62  
   fashion 112  
   home interior 65  
   use of tone 94  
 image size 152  
 image types (digital design) 147–8, 153  
 images  
   alteration of 299  
   appropriation of 299  
   cultural awareness 299–300  
   use of 299–300  
 images (digital design)  
   preparation 152  
   resolution 152–3  
 imaging software, key aspects 148–51  
 in-house designers 242–3  
 industrial design 249  
   presentation drawings 67–8  
   presentations 201  
   visual communication use 76  
 industrial designers 249, 258  
   resources used 251–2  
   specialist skills of 250–1  
   technologies used 253  
   what do they do? 249–50  
   who do they work with? 251  
 Industrial Revolution 126, 262, 264  
 informing (visual communication) 73  
 injection moulding 146  
 ink rendering 49  
 inkjet printing 142, 143  
 innovation patents 295  
 instant cameras 157  
 intaglio printing 140–1  
 intellectual property (IP) 287, 289  
   areas of design benefiting from IP  
   protection 287–8  
   who owns? 288  
   *see also* copyright; design  
   registration; moral rights; patents;  
   trademarks



interests (audience) 163, 218  
 interior design 253  
 interior designers 258  
   what do they do? 255  
 interior elevations, drawing 41  
 interiors  
   one-point perspective 13–14  
   two-point perspective 16  
 international standards 298  
 International Style (1920–80) 270–1, 279  
 Internet 170, 171, 244, 284  
 interviews 169, 172  
 inventions 187  
 IP Australia 287, 289, 293, 294, 295  
 IP rights 287–8, 289  
 isometric drawings 4–6  
   exploded view 6  
   step-by-step guide 5  
   using crating method 23  
   using isometric grid paper 4  
 isometric ellipses 21  
 italic type 117

## J

Johnston, Edward 126  
 journals 172  
 JPEG files 153, 158  
 junk mail 171  
 juxtaposition 101

## K

kerning 117  
 key movements in design 262–78  
   identifying historical connections  
   279–80

## L

landscape architects, what do they do?  
 255–6  
 landscape design 42, 253  
   presentation drawing 66  
 landscape designers 258  
 landscape plan 42  
 large sections, crosshatching 32  
 laser printing 142, 143  
 layering (applications of tone) 48  
 layers (imaging software) 148  
 layout 129  
   alignment 132  
   grid 129–31  
 leaders 34, 35  
 leading 117  
 legal issues in design 245, 287–96  
 legibility 117, 120–3  
   factors influencing 121  
   logo design 123  
 letterforms 95, 117, 124, 125, 126, 127  
 libraries 172–3  
 life cycle assessment (LCA) 301  
 'life-cycle principles' in design 300  
 ligature 117  
 light source  
   and form 51–2  
   and tone 94  
 lighting (photographs) 156–7  
 line 86–8  
   contrast in 102

line conventions  
   orthogonal drawings 29–30  
   plans and elevations 39  
 line rendering 50  
 lining numerals 118  
 linocuts 141  
 linotype machines 126  
 literary resources 172–3  
 location  
   of audience 163, 219  
   of visual communication 232  
 logo design  
   design elements in 88, 91, 92, 95  
   figure-ground in 106  
   organising researched images 175  
   and typefaces 121, 123  
 Lomo cameras 157  
 longevity, designing for 302  
 Lorem ipsum 120  
 lower-case letters 116  
 lower-case numerals 118  
 Lumiere Art & Co. 290

## M

magazines 172–3, 244, 279  
 maker culture 277  
 Maker Movement (2000–present)  
 276–8, 283  
 maker spaces 276–7, 278  
 manual modelling 145–6  
 manual printing methods 140–2  
 margins 130  
 marker (grid) 131  
 marker rendering 50, 140  
 market research 164, 169, 172, 174,  
 220, 244  
 materials  
   ceramics 60  
   composites 59  
   eco materials 58, 300  
   economic influence on development  
   280–1  
   fabrics and textiles 54–6  
   factors affecting choice of 244  
   metallic and reflective surfaces 56–7  
   plastics 57–8  
   representing 53–60  
   selection, sustainable approach to  
   302  
   technology 263  
   for visual communication, analysing  
   237–8  
 media  
   observational drawing 44–5  
   of visual communication, analysing  
   237–8  
 medium-density fibreboard (MDF) 146  
 memes 171  
 Memphis (1981–88) 275–6  
 menus 121  
 metallic surfaces 56  
 methods of visual communication,  
   analysing 237–8  
 Miedinger, Max 127  
 minimalism 279  
 mixed media for collage 139  
 mobile phone cameras 157–8  
 mock-ups 192, 194, 195–6

modelling 144  
   digital 147  
   manual 145–6  
 models  
   casting 146  
   moulding 146  
 modern typefaces 119–20, 126–7  
 modernism 263, 266, 267  
 modular system 111  
 modules 131  
 monotype 141  
 monotype machines 126  
 moral rights 287, 292  
   case study 293  
 moulding 146  
 moveable type 124, 125  
 movie posters 106, 122  
 multifunction design 302  
 multiple dimensions 34  
 multiple views (observational drawing)  
 48

## N

national standards 298  
 natural textures 53–4, 93  
 negative-positive space 105–7  
 negative tracking 118  
 Newson, Marc 85  
 non-lining numerals 118  
 normal tracking 118  
 numerals 118  
 Nuñez, Brooke 151

## O

object-oriented images 147–8  
 objectivity, in analysis 230  
 O'Brien, Gemma 128  
 observation  
   for audience research 220  
   for research 164, 167  
 observational drawing 44, 134  
   establishing hierarchy 47–8  
   media 44  
   multiple views 48  
   scale, proportion and context 45–7,  
   111  
   to generate ideas 178–9  
 offset printing 143–4  
 oil pastels 138  
 old style typefaces 119, 125  
 one-point perspective 12  
   interiors 13–14  
   step-by-step guide 12  
   using crating method 23  
 online databases 171  
 online libraries of stock photos 171  
 OpenType 118  
 Organic Design and Biomorphism  
 (1930–60) 272–3  
 organising research material 174–5  
 orthogonal drawings 24, 25–36  
   cross-sections 30–2  
   dimensioning 32–6  
   hidden detail 30  
   line conventions 29–30  
   scale 30  
   section views 41

- step-by-step guide 27–9  
third-angle projection 26  
using grid paper 29
- P**
- packaging nets 36–7  
Pantone  
  colour swatch 82, 83  
  ‘Colour of the Year’ 223  
paper and card 138–9  
  for modelling 145  
paper quality 142–3  
paper stumps 49  
paraline drawings 3–9  
pasteboard 138, 145  
pastels 138  
patents 287, 295  
  innovation patents 295  
  standard patents 295  
patterns 107–10  
  alternating 108  
  forms, shapes and structures 168  
  in nature and the constructed  
  environment 109  
  repetitive/repeating 107–8, 109  
  seamless 109, 110  
PDF files 153  
pen and ink drawing 138  
pen rendering 49  
pencil drawing 136  
pencil rendering 48–9, 136  
pencils 48, 49, 136  
personas 221  
perspective drawings 3, 9–20  
  establishing hierarchy 47–8  
  establishing your point of view 11  
  one-point perspective 12–14  
  scale and proportion 45–6, 111  
  shadows in 19  
  two-point perspective 14–20  
photo manipulation software 155, 156  
photographs  
  composition 156  
  lighting 156–7  
  planning the purpose of 156  
  in research 168, 169  
  tips for taking good 155–7  
photography 155–8  
phototypesetting 127  
pictographs 90  
pitch as an evaluation technique 203  
  key elements 203  
pixel-based editing programs 148  
planning (photographs) 156  
planometric drawings 6–9  
  in environment design 8  
  from a floor plan 8–9  
  step-by-step guide 7–8  
  using crating method 22  
plans and elevations (two-dimensional  
drawing) 37  
  abbreviations 38–9  
  dimensioning 41  
  drawing the plan view 37  
  line conventions 39  
  symbol conventions 38  
  *see also* elevations
- plastics 57–8  
plus, minus, interesting (PMI)  
  215–16  
PMS (Pantone Matching System) 83  
PNG files 153  
point (design element) 88–9  
  contrast in 102–3  
  point (type size) 119  
  point of view 11  
political change, impact on design 281  
polypropylene 146  
polystyrene 146  
POOCH model 212  
Pop design (1958–72) 273–4  
posters 105, 122, 126, 128  
Postmodern Design (1965–present)  
  274–5  
postmodernism 262, 263, 273, 275  
PPI (pixels per inch) 143  
presentation drawing 64, 135  
  for communication design 66–7  
  for environmental design 64–6  
  for industrial design 67–8  
presentations (final design) 201–2  
primary colours 79  
primary purpose of visual  
  communication 70  
primary research 169–70  
print resolution 142  
printer papers 143  
printing methods 140  
  digital methods 142, 143–4  
  manual methods 140–2  
  and paper quality 142–3  
  three-dimensional processes  
  144–7  
printing press 124–5  
process colour 82  
product responsibility 304  
production 201–2, 244–5, 253  
projection lines (dimensioning) 33  
promotion 71  
promotional posters 128  
proportion 110–12  
  fashion illustration 112  
  overlapped objects 47  
  and scale, observational drawing  
  45–6, 111  
proprietary file types 153  
prototypes 192, 194, 195–6, 251  
proximity 101  
purpose (design brief) 163  
purposes of visual communication  
  70  
  advertising 70–1  
  analysing 231–2  
  depiction 71–2  
  guiding 74–5  
  identifying 74  
  informing 73  
  other purposes 75–6  
  promotion 71  
  teaching 72–3
- Q**
- qualitative research 167, 169  
quality products 302
- quantitative research 167, 169  
questionnaires 172
- R**
- Radical Design and Anti-Design  
(1968–78) 274  
radius 22  
rag paper 138  
Rams, Dieter 249, 250  
random words 208  
raster images 148  
raster programs 51, 147, 152  
RAW files 158  
recyclability 301, 302, 303, 304  
referencing 296–7  
refinement of ideas 191–5, 196  
  mock-ups and prototypes 192, 194,  
  195–6  
reflective surfaces 56, 57  
reflective thinking 206, 216  
  techniques 215–16  
regional standards 298  
registered trademarks 293  
regulations 298–9  
relief printing 141  
religious beliefs 163, 218, 283  
rendering 48  
  airbrush rendering 51  
  computer rendering 50–1  
  dot rendering 49, 89  
  elevations 41  
  with ink or pen 49  
  line rendering 50  
  marker rendering 50, 140  
  pencil rendering 48–9, 136  
  techniques 48  
  textures and materials 53–60  
  to represent form 51–2  
Renner, Paul 127  
repetitive/repeating patterns 107–8, 109  
research 164–75  
  annotating 175  
  attribution 296–7  
  collecting 170–1  
  in environmental design 260  
  existing products 165  
  field trip 166  
  organising and interpreting 174–5  
  in professional environments 243–4  
  types of 167–70  
  what is it? 167  
research resources  
  demographic data 173–4  
  electronic resources 171  
  found materials 171  
  historical resources 173  
  literary resources 172–3  
  verbal resources 172  
resolution (images) 152–3  
resolution (of a design) 201–2  
retro design 262  
return brief 162, 243  
RGB colours 82, 83, 142, 154  
  as web safe colours 154  
road signs 90  
Roman typefaces 118, 125  
Russian doll 210

**S**

sans serif typefaces 95, 116, 126, 127  
 saving your work 148  
 scale 112–13  
   orthogonal drawings 30  
   and proportion, perspective drawing 45–6  
   to emphasise shadow 19  
 scale models 112–13  
 SCAMPER 212–14  
 screenprinting 141–2  
 script typefaces 96, 120  
 seamless patterns 109, 110  
 secondary colours 79  
 secondary purpose of visual communication 70  
 secondary research 169, 170  
 section views (orthogonal drawings) 41  
 sections, dimensioning 34–5  
 selection tools (imaging software) 150  
 self-education for designers 244  
 serif 118  
 serif typefaces 95, 118, 125  
 shadows  
   photography 156–7  
   and three-dimensional form 52  
   in two-point perspective 19–20  
 shape 89–91  
   contrast in 102–3  
   shocking imagery 226–7  
 side view (orthogonal drawing) 26, 28, 29, 37  
 signage 74, 75  
 site surveys 260  
 sketching 3, 44, 62, 179–83  
   multiple views 48  
 slab serif typefaces 96, 120, 126  
 SLR (single lens reflex) cameras 157, 158  
 social context  
   of design 282–3  
   impact on design movements 279–80  
 social media 171, 222, 282, 284  
   analysis 221  
 social sustainability 300  
 socioeconomic status (audience) 162, 218  
 soft pencils 48  
 spacing 117, 118  
 specialist professionals 244–5  
 sphere 21  
 spot colour 83  
 standard patents 295  
 standards 287, 298, 300  
 stencils 141–2  
 stock 142–3  
 stock photos 171  
 strawboard 145  
 Streamline (1930–60) 272  
 stroke (letterform) 118  
 studio lighting 156  
 styrofoam 146  
 subjective research 167  
 subtractive colour mode 154  
 surveys 172, 174  
 sustainability 300  
   economic 300

environmental 300  
 social 300  
 strategies for 301–4  
 swash 118  
 SWOT analysis 216  
 symbol conventions (plans) 38  
 symmetrical balance 98

**T**  
 tapered features, dimensioning 35–6  
 target audience 73  
 teaching 72–3  
 teamwork 245  
 technology  
   and design 283–4  
   used by industrial designers 253  
   *see also* CAD; CADD; digital design  
 terminal 118  
 terms and language, use of appropriate 230  
 tertiary colours 79  
 textiles 54–6  
 texture(s) 44, 91–3  
   contrast in 102  
   fabrics and textiles 54–6  
   natural 53–4, 93  
   representing 53–60  
 third-angle projection 26  
 3D drawing 3–23  
 3D graphics software 147  
 3D modelling 147  
 3D printing 144–5  
 3D processes 144–7  
 thumbnail sketches 175–6, 179  
 TIFF files 153  
 tonal scale 52, 93  
 tone 10, 89, 93–5  
   applying 94  
   contrast in 102  
   and light source 94  
   observational drawing 44  
   rendering 48, 50, 52  
 top view (orthogonal drawing) 26, 28, 37  
 toy cameras 157  
 tracing paper 138  
 tracking 118  
 trademarks 287, 293–4  
 transitional sans serif typefaces 120  
 transitional typefaces 119  
 trees 54  
 trend forecasting 164  
 trends in design 222–3, 282  
 trialling and testing (design alternatives) 184, 188–9  
 Tschichold, Jan 127  
 two-dimensional drawing 24–37  
   in environmental design 37–9  
 two-point perspective 14  
   architectural exteriors 16  
   architectural interiors 16  
   from a floor plan 17–18  
   shadows in 19–20  
   step-by-step guide 15  
   using crating method 23  
 type 95, 97  
   contrast in 101

type classification 119–20  
 type foundry 119  
 type size 119  
 type styles 95–7  
 typefaces 95–7, 115, 116, 119–20  
   developments in the 18th and 19th centuries 125–6  
   early 125  
   and legibility 121  
   20th-century modernism 126–7  
 typographic language 115–19  
 typography 95, 115–23  
   history 124–9  
   legibility 120–3

**U**

upper-case letters 116  
 upper-case numerals 118  
 usability testing 222  
 user analysis 225–6  
 user interface design 224–5  
 users *see* audience

**V**

vacuum moulding 146  
 vector-based programs 50, 147  
 vector images 147–8  
 verbal resources 172  
 Vienna Secession (1897–1905) 266  
 viewpoint 8  
 visual communication design industry  
   practice 242–5, 258–9  
 visual devices 226–30  
   brand power 229–30  
   emotion 229  
   humour 227–8  
   metaphor 229  
   shock 226–7  
 visual language 218  
 visual metaphor 229  
 visual thinking 25  
 visualisation drawing 62–4, 134–5, 208  
   tips 180  
   to generate ideas 179–83  
 Von Glitschka 248, 288

**W**

warm colours 81  
 wartime, influence on design 280, 281  
 waste minimisation 300  
 watercolour 136–7  
 watercolour paints 136  
 watercolour pencils 49, 136  
 wayfinding 74, 75  
 weave 55  
 web safe colours 154  
 weft 55  
 white space 99–100  
 wood, for modelling 146  
 wood grain 53, 54  
 woodcut printing 141  
 word lists 208–9  
 woven fabrics 54

**X**

x-height 115, 119